



## 2026 Sidewalk Program

The 2026 Sidewalk Program will open at 8 a.m., Wednesday, April 1, 2026. The intent of the program is to work with homeowners to replace sidewalks.

The program reimburses the homeowner a set per square foot amount for sidewalks and per lineal foot for curb and curb/sidewalk combination (when the sidewalk and curb are next to each other). This amount is set by the town council. This **IS NOT** a 50/50 program. It is the homeowner's responsibility to obtain a contractor, provide the town specs, and pay for services.

Applications are available at [www.in.gov/towns/culver/services/](http://www.in.gov/towns/culver/services/). Completed applications, including a sketch of the property and sidewalk to be replaced, will be accepted via email beginning at 8 a.m. local time, Wednesday, April 1, 2026. Applications will be reviewed in the order they are received after 8 a.m. Applications may be emailed to [kheim@townofculver.org](mailto:kheim@townofculver.org). Applications will be accepted through July 1 or until the funds set aside for the sidewalk program are committed, whichever is first. Applications for completed projects do not qualify and will not be accepted.

Once applications are received, they will be reviewed by the utilities superintendent and the measurements will be confirmed by him or one of his employees. The town reserves the right to make adjustments to measurements based on the conditions of the site and will not participate in any concrete placed outside the measurements applied for.

If your site qualifies for the program, you will receive a letter from the clerk-treasurer confirming your participation, the amount of reimbursement, and the next steps. Please do not start your project until you have received the confirmation letter.

Sidewalks and curbs must meet ADA and town specifications in order to qualify for reimbursement. You are responsible for making arrangements with a contractor and providing the town specifications to them. You also are responsible for safety marking during construction, removing the rubble, and for returning the construction area to its original condition.

Prior to placing concrete, you or your contractor **must call** the utilities superintendent for an inspection. He can be reached at 574.292.3943. Failure to do so will result in the loss of reimbursement and may result in the replacement of the concrete at the owner's expense.

If there are any further questions, please call Town Hall at 574.842.3140.

Variation from typical 5' width  
must receive approval from  
Building Commissioner or Street Superintendent  
Prior to installation.

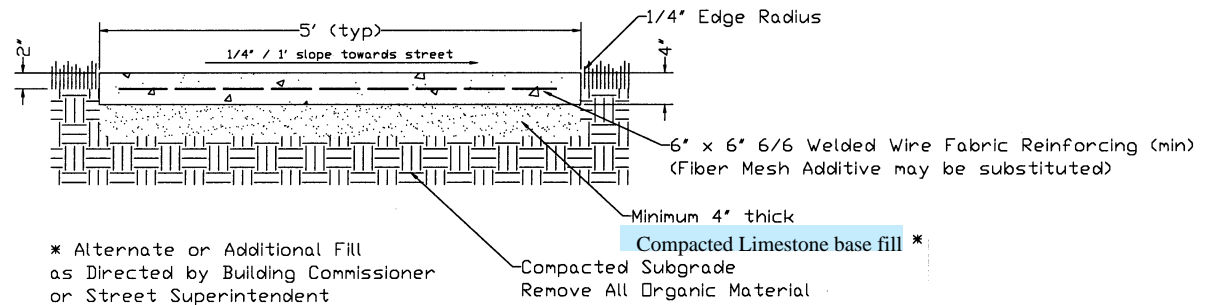

*Standard Sidewalk Cross Section*

*Course Broomed Finish Perpendicular to Travel Path*

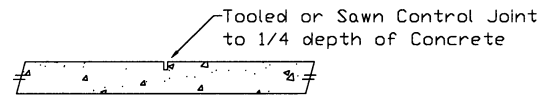

*Typical Control Joint Cross Section*

*Control Joint Spacing to be  
Equal to or less than Sidewalk Width*

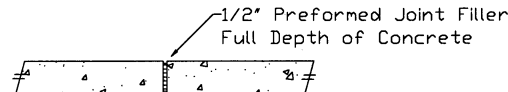

*Typical Expansion Joint Cross Section*

*Maximum Expansion Joint Spacing shall be 25 feet.*

Town of Culver, Indiana

200 East Washington Street  
Culver, IN 46511

Phone: (574) 842-3140 [www.townofculver.org](http://www.townofculver.org)

email: [townmanager@townofculver.org](mailto:townmanager@townofculver.org)

TDC Street Detail Sheet 2

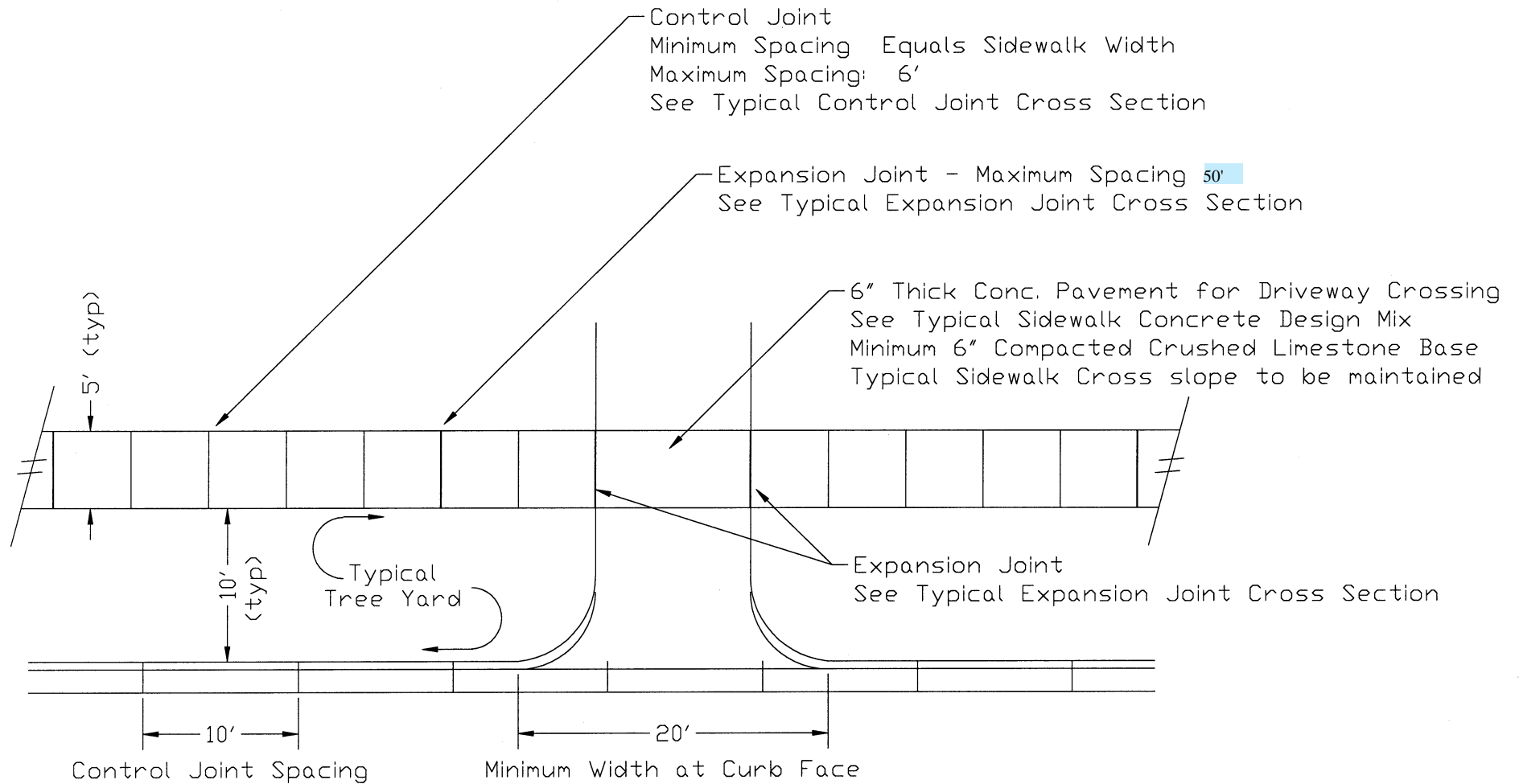

Gutter Line shall continue across end of drive.  
Storm Water flow shall not be impeded by drive.

Town of Culver, Indiana

200 East Washington Street  
Culver, IN 46511  
Phone: (574) 842-3140 www.townofculver.org  
email: townmanager@townofculver.org

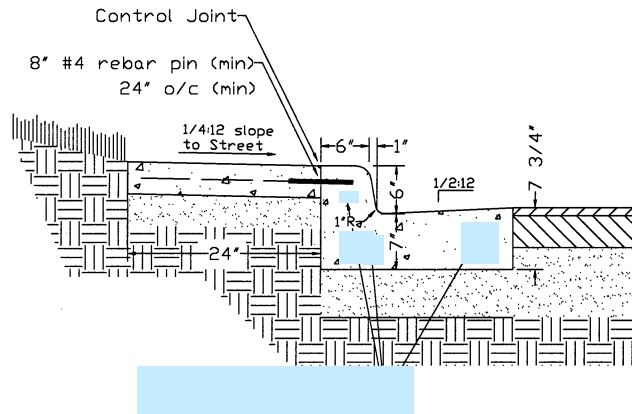

*Courtesy Drop-off Cross Section*  
 1/8" x 2" sawcut @ 6' o/c (min)

A 24" wide Courtesy Drop-off Walk may be provided at the curb line within tree yard. Installation must be approved by the Building Commissioner and Tree Commission.

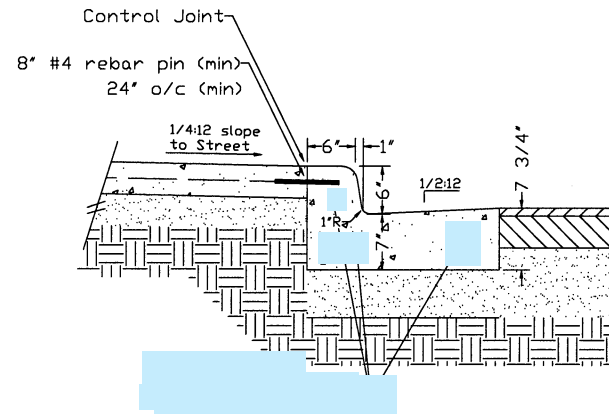

*Combined Curb & Walk Cross Section*  
 1/8" x 2" sawcut @ 10' o/c

Concrete walk and curb may be poured continuous. Where concrete walk and curb are poured continuous reinforcing similar to the pins shown above shall be provided and a tooled or saw cut control joint shall be provided separating the walk from the curb as shown.

## Town of Culver, Indiana

200 East Washington Street  
 Culver, IN 46511

Phone: (574) 842-3140 www.townofculver.org  
 email: townmanager@townofculver.org

New curbs shall be installed as per the "Combined Curb & Gutter Cross Section". Variations shall be allowed only with approval of the Building Commissioner or Street Superintendent prior to installation. The "Straight Curb Cross Section" shown herein may only be used with the approval of the Building Commissioner or Street Superintendent prior to installation.

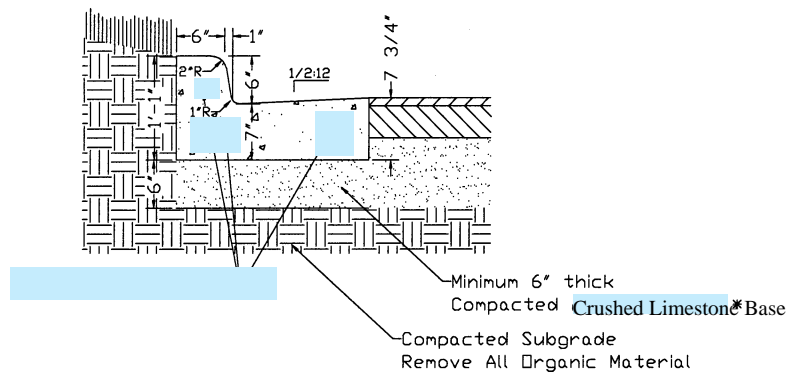

Combined Curb & Gutter Cross Section

1/8" x 2" sawcut @ 10' o/c

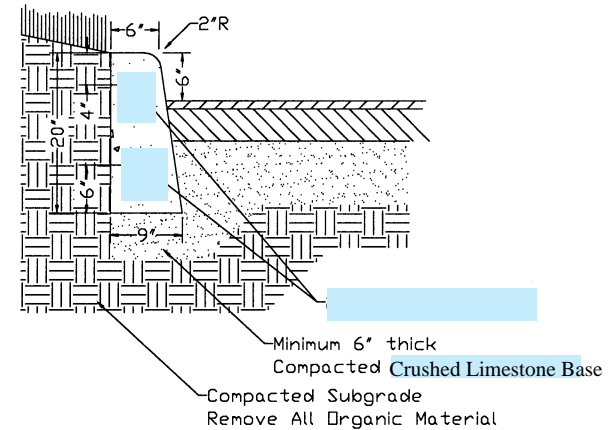

Straight Curb Cross Section

1/8" x 2" sawcut @ 10' o/c

See Town of Culver Street Specifications  
for approved concrete design mix.

## Town of Culver, Indiana

200 East Washington Street  
Culver, IN 46511  
Phone: (574) 842-3140 [www.townofculver.org](http://www.townofculver.org)  
email: [townmanager@townofculver.org](mailto:townmanager@townofculver.org)

New curbs shall be installed as per the "Combined Curb & Gutter Cross Section". Variations shall be allowed only with approval of the Building Commissioner or Street Superintendent prior to installation. The "Straight Curb Cross Section" shown herein may only be used with the approval of the Building Commissioner or Street Superintendent prior to installation.

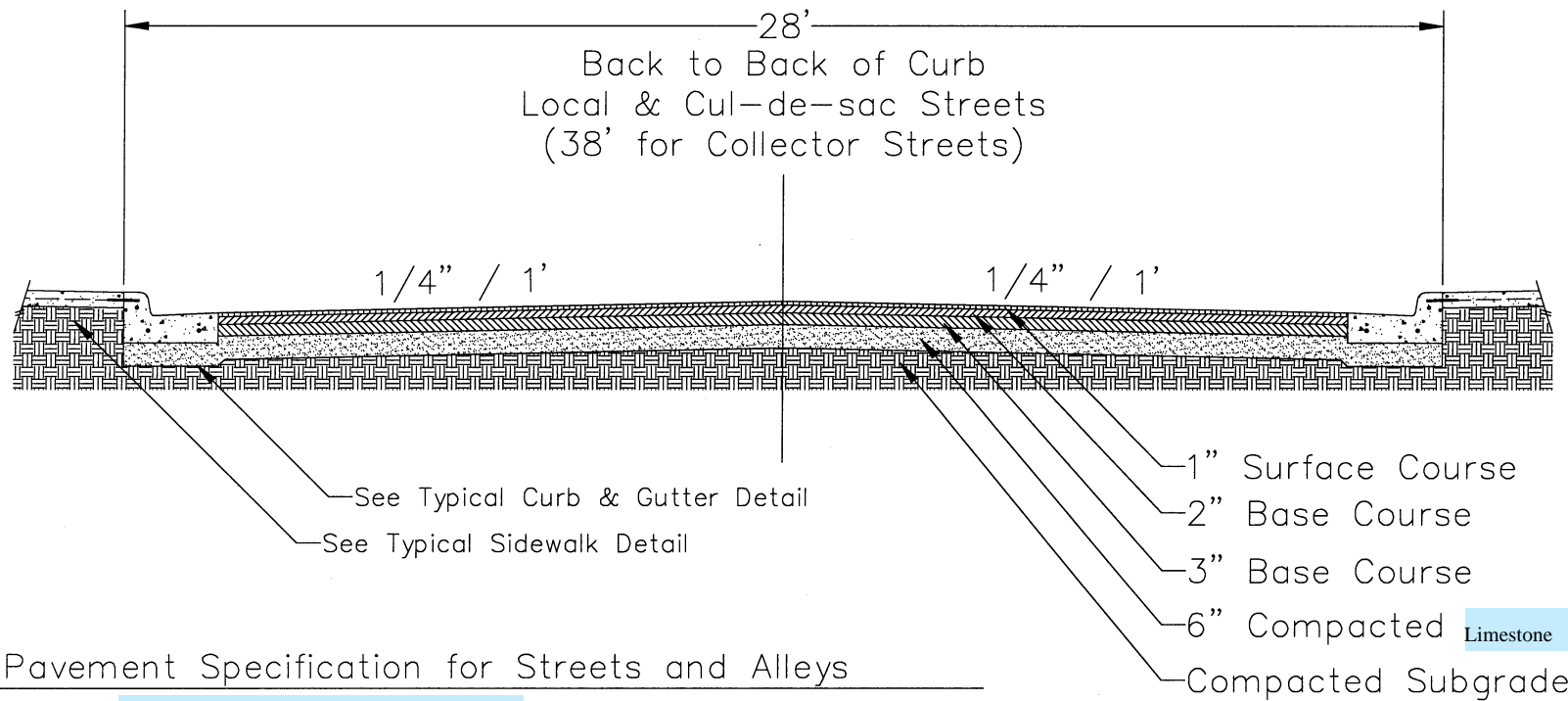

Asphalt Pavement Specification for Streets and Alleys

- 6" compacted crushed limestone
  - 3" base course asphalt
  - 2" base course asphalt
  - 1" surface course asphalt
- (See Town of Culver Street Specification for additional detail)

Town of Culver, Indiana

200 East Washington Street  
 Culver, IN 46511  
 Phone: (574) 842-3140 www.townofculver.org  
 email: townmanager@townofculver.org

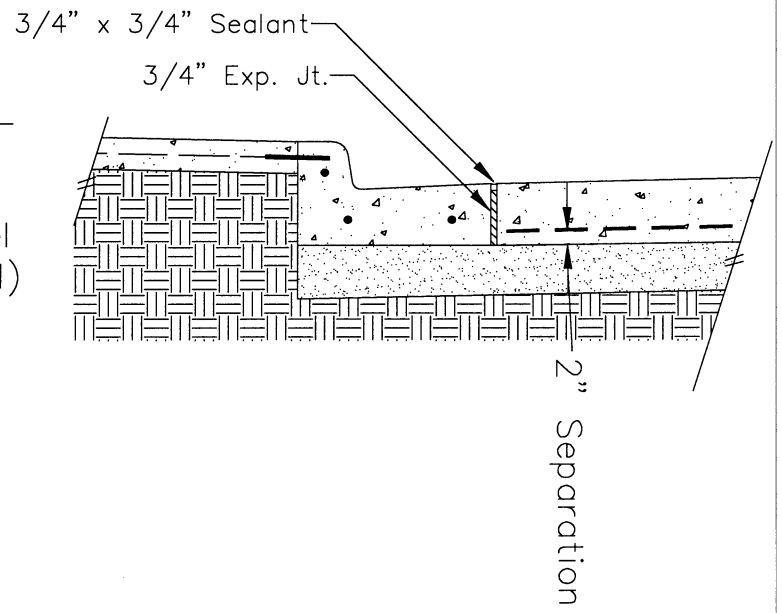

Concrete Pavement Specification for Streets and Alleys

- 6" compacted crushed limestone
- 8" 4000 psi (min.) Reinforced Concrete
- Minimum 6" x 6" 4/4 welded wire fabric reinforcing steel
- (See Town of Culver Street Specification for additional detail)

Town of Culver, Indiana

200 East Washington Street  
 Culver, IN 46511  
 Phone: (574) 842-3140 www.townofculver.org  
 email: townmanager@townofculver.org

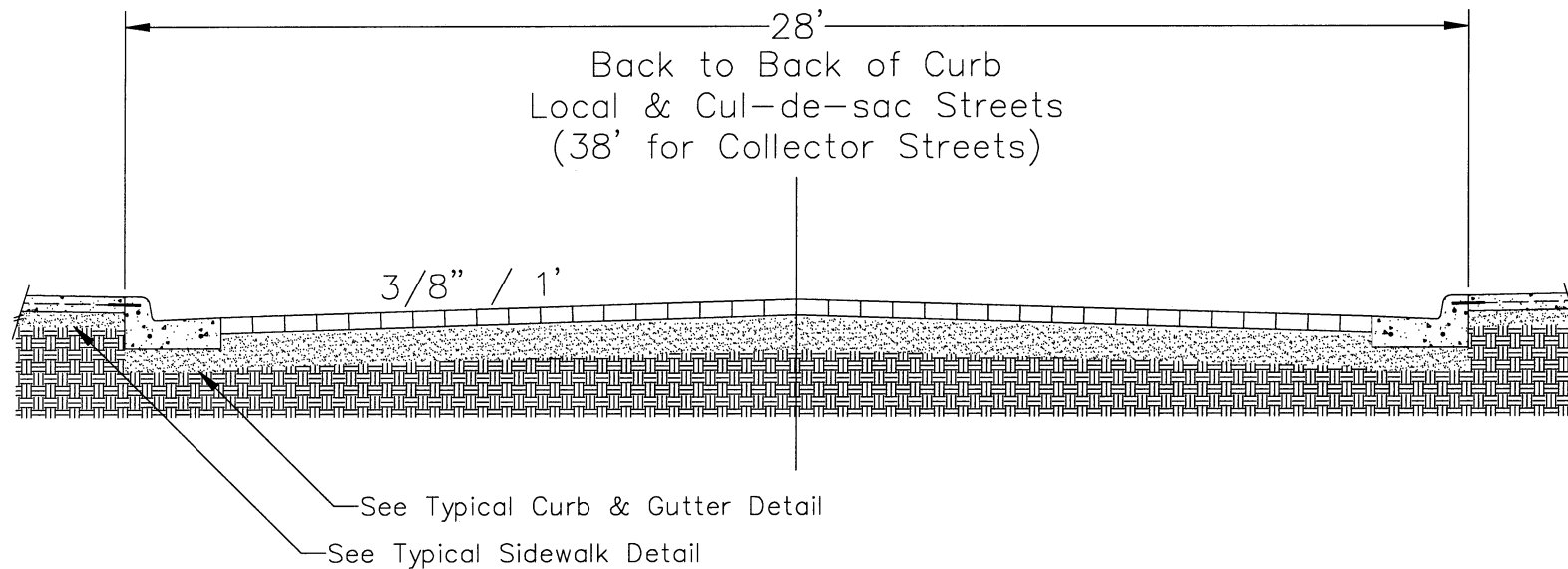

### Brick Pavement Specification for Streets and Alleys

8" compacted crushed limestone

1/2"-3/4" sand base (compact & fill all voids)

Town of Culver preapproved street brick or concrete pavers

- 1) Compact Pavers and sweep sand into joints
- 2) Pavers to meet same smoothness requirements as asphalt pavement specification

### Town of Culver, Indiana

200 East Washington Street

Culver, IN 46511

Phone: (574) 842-3140 [www.townofculver.org](http://www.townofculver.org)

email: [townmanager@townofculver.org](mailto:townmanager@townofculver.org)

# Town of Culver

## 2026 Sidewalk & Curb Program Application

Name \_\_\_\_\_ Daytime Phone \_\_\_\_\_

Culver Address \_\_\_\_\_

Mailing Address (if different) \_\_\_\_\_

Name of property owner (if different from applicant) \_\_\_\_\_

If you do not plan to complete your sidewalk project in the year in which you apply for funds, do not apply for the sidewalk program. You must complete your project in the year in which you receive approval as funds will not roll over to the following year. Not completing your project will disqualify you from applying in a future round.

I understand sidewalks and curbs must meet ADA and town specifications in order to qualify for reimbursement. I will make my own contractor arrangements and will be responsible for safety marking during construction as well as removal of rubble. I understand that I/contractor must call for an inspection prior to placing concrete and failure to do so will result in loss of reimbursement and may result in replacement of said concrete at owner expense.

Owner Signature \_\_\_\_\_ Contractor Signature \_\_\_\_\_

**Reimbursement Rates**

**Sidewalks**  
\$4 per square foot

**Curbs**  
\$21 per linear foot

**Curb/Sidewalk Combination**  
\$39 per linear foot  
*This applies when the curb and sidewalk are not separated by lawn*

---

The town reserves the right to make adjustments to measurements based on conditions of the site. The Town will not participate in any concrete placed outside measurement applied for.

**Check option(s) that apply and provide measurements.**

**Sidewalk**

Length \_\_\_\_\_ Width \_\_\_\_\_ Square Footage \_\_\_\_\_

Length \_\_\_\_\_ Width \_\_\_\_\_ Square Footage \_\_\_\_\_

**Curb**                       **Curb/Sidewalk Combination**

Length \_\_\_\_\_                      Length \_\_\_\_\_

Length \_\_\_\_\_                      Length \_\_\_\_\_

*Applications will be considered in the order they are received*

Town Use Only					
<u>Measurement Inspection</u>		<u>Inspection prior to concrete placement</u>		<u>Final Inspection</u>	
Employee _____		Employee _____		Employee _____	
Date _____		Date _____		Date _____	
Sidewalk		Specifications Met (Y/N)		Sidewalk	
Sq.Ft. _____ x _____ = _____		Stone _____ Explanation _____		Sq.Ft. _____ x _____ = _____	
Sq.Ft. _____ x _____ = _____		Forms _____ Explanation _____		Sq.Ft. _____ x _____ = _____	
		Thickness: 6" _____ 4" _____			
Curb	Curb/Sidewalk	Reimbursement Date _____		Curb	Curb/Sidewalk
Ln.Ft. _____	Ln.Ft. _____	Total Reimbursement \$ _____		Ln.Ft. _____	Ln.Ft. _____
Ln.Ft. _____	Ln.Ft. _____			Ln.Ft. _____	Ln.Ft. _____