



STATE OF INDIANA
AN EQUAL OPPORTUNITY EMPLOYER

B57250

STATE BOARD OF ACCOUNTS
302 WEST WASHINGTON STREET
ROOM E418
INDIANAPOLIS, INDIANA 46204-2765

Telephone: (317) 232-2513
Fax: (317) 232-4711
Web Site: www.in.gov/sboa

September 17, 2021

Board of Commissioners
Housing Authority of the City of Huntingburg
1102 Friendship Village
Huntingburg, IN 47542

We have reviewed the audit report of the Housing Authority of the City of Huntingburg which was opined upon by Goldie Roberts, CPA, Independent Public Accountant, for the period January 1, 2020 to December 31, 2020. Per the *Independent Auditor's Report*, the financial statements included in the report present fairly the financial condition of the Housing Authority of the City of Huntingburg as of December 31, 2020, and the results of its operations for the period then ended, on the basis of accounting described in the report.

In our opinion, the audit report was prepared in accordance with the guidelines established by the State Board of Accounts.

The audit report is filed with this letter in our office as a matter of public record.

A handwritten signature in blue ink that reads "Paul D. Joyce".

Paul D. Joyce, CPA
State Examiner

HOUSING AUTHORITY OF THE CITY OF HUNTINGBURG

AUDITED FINANCIAL STATEMENTS

Huntingburg, Indiana

December 31, 2020

Goldie Roberts

Certified Public Accountant

8518 S Kays Chapel Rd
Fredericksburg, IN 47120
812-472-3527

HOUSING AUTHORITY
OF THE CITY OF HUNTINGBURG

Huntingburg, Indiana
December 31, 2020

TABLE OF CONTENTS

	<u>Page</u>
Independent Auditor's Report	1
Management's Discussion and Analysis	i
<u>FINANCIAL STATEMENTS</u>	
Statement of Net Position	3
Statement of Revenues, Expenses and Changes in Fund Net Position	4
Statement of Cash Flows	5
Notes to Financial Statements	7
<u>REQUIRED SUPPLEMENTARY INFORMATION</u>	
Schedule of the Authority's Proportionate Share of the Net Pension Liability	20
Schedule of the Authority's Contributions	21
<u>SUPPLEMENTAL FINANCIAL INFORMATION</u>	
Combining Schedule of Program Net Position	22
Combining Schedule of Program Revenues, Expenses and Changes in Fund Net Position	23
Statement and Certification of Actual Capital Fund Grant Costs-Completed Financial Data Schedule	24
Notes to Supplemental Financial Information	25
	30
<u>OTHER REPORTS</u>	
Report on Internal Control over Financial Reporting and on Compliance and Other Matters Based on an Audit of Financial Statements Performed in Accordance with <i>Government Auditing Standards</i>	31
Schedule of Findings and Responses	33

Goldie Roberts

Certified Public Accountant

8518 S Kays Chapel Rd.
Fredericksburg, IN 47120

INDEPENDENT AUDITOR'S REPORT

Board of Commissioners
Housing Authority of the
City of Huntingburg
1102 Friendship Village
Huntingburg, Indiana

I have audited the accompanying financial statements of the Housing Authority of the City of Huntingburg ("the Authority") which comprise the Statement of Net Position as of December 31, 2020, and the related Statements of Revenues, Expenses and Changes in Fund Net Position, and Cash Flows for the year then ended, and the related Notes to the Financial Statements, which collectively comprise the Housing Authority of the City of Huntingburg's financial statements as listed in the table of contents.

Management's Responsibility for the Financial Statements

Management is responsible for the preparation and fair presentation of these financial statements in accordance with accounting principles generally accepted in the United States of America; this includes the design, implementation and maintenance of internal control relevant to the preparation and fair presentation of financial statements that are free from material misstatement, whether due to fraud or error.

Auditor's Responsibility

My responsibility is to express an opinion on these financial statements based on my audit. I conducted my audit in accordance with auditing standards generally accepted in the United States of America and the standards applicable to financial audits contained in *Government Auditing Standards*, issued by the Comptroller General of the United States. Those standards require that I plan and perform the audit to obtain reasonable assurance about whether the financial statements are free from material misstatement.

An audit involves performing procedures to obtain audit evidence about the amounts and disclosures in the financial statements. The procedures selected depend on the auditor's judgment, including the assessment of the risks of material misstatement of the financial statements, whether due to fraud or error. In making those risk assessments, the auditor considers internal control relevant to the Authority's preparation and fair presentation of the financial statements in order to design audit procedures that are appropriate in the circumstances, but not for the purpose of expressing an opinion on the effectiveness of the Authority's internal control. Accordingly, I express no such opinion. An audit also includes evaluating the appropriateness of accounting policies used and the reasonableness of significant accounting estimates made by management, as well as evaluating the overall presentation of the financial statements.

I believe that the audit evidence I have obtained is sufficient and appropriate to provide a basis for my audit opinion.

Opinion

In my opinion, the financial statements referred to above present fairly, in all material respects, the financial position of the Housing Authority of the City of Huntingburg as of December 31, 2020, and the changes in financial position and cash flows thereof for the year then ended in accordance with accounting principles generally accepted in the United States of America.

Other Matters

Required Supplementary Information

Accounting principles generally accepted in the United States of America require that the Management's Discussion and Analysis on pages i through viii and Schedule of the Proportionate Share of the Net Pension Liability and the Schedule of the Authority's Contributions on pages 20 through 21 be presented to supplement the financial statements. Such information, although not a part of the financial statements, is required by the Governmental Accounting Standards Board who considers it to be an essential part of financial reporting for placing the financial statements in an appropriate operational, economic, or historical context. I have applied certain limited procedures to the required supplementary information in accordance with auditing standards generally accepted in the United States of America, which consisted of inquiries of management about the methods of preparing the information and comparing the information for consistency with management's responses to my inquiries, the financial statements, and other knowledge I obtained during my audit of the financial statements. I do not express an opinion or provide any assurance on the information because the limited procedures do not provide me with sufficient evidence to express an opinion or provide any assurance.

Other Supplementary Information

My audit was conducted for the purpose of forming an opinion on the Authority's financial statements as a whole. The accompanying Financial Data Schedule and the other supplemental information as listed in the table of contents are presented for purposes of additional analysis and are not a required part of the financial statements.

In regard to, the Financial Data Schedule and the other supplemental information as listed in the table of contents, such information is the responsibility of management and was derived from and relates directly to the underlying accounting and other records used to prepare the financial statements. Such information has been subjected to the auditing procedures applied in the audit of the financial statements and certain additional procedures, including comparing and reconciling such information directly to the underlying accounting and other records used to prepare the financial statements or to the financial statements themselves, and other additional procedures in accordance with auditing standards generally accepted in the United States of America. In my opinion, the Financial Data Schedule and the other supplemental information as listed in the table of contents is fairly stated, in all material respects, in relation to the financial statements as a whole.

Other Reporting Required by Government Auditing Standards

In accordance with *Government Auditing Standards*, I have also issued my report dated September 10, 2021 on my consideration of the Housing Authority of the City of Huntingburg's internal control over financial reporting and on my tests of its compliance with certain provisions of laws, regulations, contracts and grant agreements and other matters. The purpose of that report is solely to describe the scope of my testing of internal control over financial reporting and compliance and the results of that testing, and not to provide an opinion on the effectiveness of the Housing Authority of the City of Huntingburg's internal control over financial reporting or on compliance. That report is an integral part of an audit performed in accordance with *Government Auditing Standards* in considering the Housing Authority of the City of Huntingburg's internal control over financial reporting and compliance.

Goldie Roberts

Certified Public Accountant

Fredericksburg, Indiana
September 10, 2021

HOUSING AUTHORITY OF THE CITY OF HUNTINGBURG
Huntingburg, Indiana

MANAGEMENT DISCUSSION AND ANALYSIS
December 31, 2020

Management's Discussion and Analysis

As management of the Housing Authority of the City of Huntingburg, we offer the readers of the Authority's financial statements this narrative overview and analysis of the financial activities of the Authority for the year ended December 31, 2020. We encourage readers to consider the information presented here in conjunction with the Authority's financial statements.

Questions concerning any of the information provided in this report or requests for additional information should be addressed to the Heidi Reller, Executive Director of the Huntingburg Housing Authority at 812-683-2513.

Overview of the Financial Statements

The financial statements included in this annual report are those of a special-purpose government engaged in a business-type activity. The following statements are included:

- Statement of Net Position – reports the Authority's current financial resources (short term spendable resources) with capital assets and long-term debt obligations.
- Statement of Revenues, Expenses, and Changes in Net Position reports the Authority's operating and non-operating revenues, by major source along with operating and non-operating expenses and capital contributions.
- Statement of Cash Flows – reports the Authority's cash flows from operating, investing, capital and non-capital activities.

Our analysis of the Authority as a whole, begins on the next page. The most important question asked about the Authorities finances is "Is the Authority as a whole better or worse off as a result of the year's activities?"

The attached analysis of entity wide Net Position, revenues, and expenses are provided to assist with answering the above question. This analysis includes all assets and liabilities using the accrual basis of accounting. Accrual accounting is similar to the accounting used by most private sector companies. Accrual accounting recognizes revenues and expenses when earned regardless of when cash is received or paid.

Our analysis also presents the Authority's Net Position and changes in them. One can think of the Authority's Net Position as the difference between what the Authority own's (assets) to what the Authority owes (liabilities). The change in Net Position analysis will assist the reader with measuring the health or financial position of the Authority.

Over time, significant changes in the Authorities Net Position are an indicator of whether its financial health is improving or deteriorating. To fully assess the financial health of any Authority the reader must also consider other non-financial factors such as changes in family composition, fluctuations in the local economy, HUD mandated program administrative changes, and the physical condition of the Authorities capital assets.

HOUSING AUTHORITY OF THE CITY OF HUNTINGBURG
Huntingburg, Indiana

MANAGEMENT DISCUSSION AND ANALYSIS
December 31, 2020

To fully understand the financial statements of the Housing Authority, one must start with an understanding of what the Authority actual does. The following is a brief description of the programs and services that the Authority provides for the residents of the City of Huntingburg:

Low Income Public Housing

The Housing Authority owns 50 units at 1 site in Huntingburg. The 50 units are separated into two areas, League Circle which is a family site with 20 units and Friendship Village which has 30 elderly units. The Authority is responsible for the management, maintenance and utilities for all units and sites. On an annual basis, the Authority submits a request for funding known as the Calculation of Operating Fund Subsidy. The basic concept of the Calculation of Operating Subsidy is that the Authority has an Allowable Expense Level, Allowable Utilities Expense Level and Audit Costs and that HUD will fund the difference between the Allowable Expenses and the amount of rents that the Authority can charge the Authority's tenants.

Condensed Comparative Financial Statements

Analysis of Entity Wide Net Position (Statement of Net Position)

Total Assets for FYE 2019 was \$1,398,888 and at FYE 2019 the amount was \$1,230,492. This represents a net increase of \$162,506, or 13.2%.

Cash increased by \$76,094. This was due to having a profit for the year.

Other Current Assets decreased by \$473. Other current assets decreased primarily as a result of decreases in accounts receivables and prepaid expenses.

Capital Assets increased by \$86,885. The change in Capital Assets will be presented in the section entitled Analysis of Capital Asset Activity.

Current Liabilities increased by \$8,398. This increase in current liabilities was due to a increase in amounts due to other governmental entities.

Non-Current Liabilities decreased by \$2,805. Non-Current liabilities decreased due to a decrease in accrued pension and OPEB liabilities.

The table on the next page illustrates our analysis:

HOUSING AUTHORITY OF THE CITY OF HUNTINGBURG
Huntingburg, Indiana

MANAGEMENT DISCUSSION AND ANALYSIS
December 31, 2020

	<u>2020</u>	<u>2019</u>	<u>Net Change</u>	<u>Percent Variance</u>
Cash	\$ 389,277	\$ 313,183	\$ 76,094	24.3%
Other Current Assets	19,516	19,989	(473)	-2.4%
Capital Assets	982,891	896,006	86,885	9.7%
Deferred Outflows of Resources	7,204	1,314	5,890	448.2%
Total Assets and Deferred Outflows of Resources	\$ 1,398,888	\$ 1,230,492	\$ 162,506	13.2%
Current Liabilities	\$ 42,702	\$ 34,304	\$ 8,398	24.5%
Non Current Liabilities	32,072	34,877	(2,805)	-8.0%
Deferred Inflows of Resources	6,456	5,086	1,370	26.9%
Total Liabilities and Deferred Inflows of Resources	81,230	74,267	6,963	9.4%
Investment in Capital Assets	982,891	896,006	86,885	9.7%
Unrestricted Net Position	334,767	260,219	74,548	28.6%
Total Liab and Net Position	\$ 1,398,888	\$ 1,230,492	\$ 161,433	13.1%

Analysis of Entity Wide Revenues (Statement of Activities)

Total Revenue for FYE 2020 was \$519,106 and for FYE 2019 the amount was \$466,622 for an increase of \$52,484. This change occurred due to an increase in other income and Capital Grants.

Tenant Revenue increased by \$5,400, or 2.8%. Tenant revenue increased because of higher rents collected.

HUD Operating Grants decreased by \$97,299, or by 53.8% due to an increase in Capital Funds received.

HUD Capital Grants increased by \$32,253. Part of 2019 Operations money was drawn down in 2020.

Other Income increased by \$110,805, or 422.9%.

	<u>2020</u>	<u>2019</u>	<u>Net Change</u>	<u>Percentage Change</u>
Total Tenant Revenue	\$ 200,666	\$ 195,266	\$ 5,400	2.80%
HUD Operating Grants	83,484	180,783	(97,299)	-53.80%
HUD Capital Grants	94,119	61,866	32,253	100.00%
Other Income	137,004	26,199	110,805	422.90%
Investment Income	3,833	2,508	1,325	100.00%
Total Revenue	\$ 519,106	\$ 466,622	\$ 52,484	11.20%

HOUSING AUTHORITY OF THE CITY OF HUNTINGBURG
Huntingburg, Indiana

MANAGEMENT DISCUSSION AND ANALYSIS
December 31, 2020

Analysis of Entity Wide Expenditures

Total Expenditures for FYE 2020 were \$357,673 as compared to the \$372,322 of total expenditures for FYE 2019. Comparatively, FYE 2020 expenditures decreased by \$14,649, or 3.9% from FYE 2019 expenditures. Changes by major expense category will be presented below.

Administrative expenses decreased by \$15,571, or 12.5%. This decrease was attributable to decreases to other administrative expenses.

Maintenance expenditures decreased by \$16,620, or 23.3%. Maintenance costs decreased due to of decreases in maintenance wages and benefits, material costs and contract costs.

Protective Services decreased in 2020 as most of the equipment was realized in 2019.

The table below illustrates our analysis:

	2020	2019	Net Change	Percent Variances
Administrative	\$108,658	\$124,229	\$ (15,571)	-12.5%
Tenant Services	12,460	843	11,617	1378.1%
Utilities	63,697	59,682	4,015	6.7%
Maintenance	54,564	71,184	-16,620	-23.3%
Protective Services	762	15,278	-14,516	-95.0%
General Expense	51,760	38,264	13,496	35.3%
Total Operating Expenditures	291,901	309,480	-17,579	-5.7%
Extraordinary Maintenance	0	9,924	-9,924	-100.0%
Depreciation Expense	65,772	52,918	12,854	24.3%
Total Expenses	\$357,673	\$372,322	\$ (14,649)	-3.9%

HOUSING AUTHORITY OF THE CITY OF HUNTINGBURG
Huntingburg, Indiana

MANAGEMENT DISCUSSION AND ANALYSIS

December 31, 2020

Percentage of Total Expenses by Category

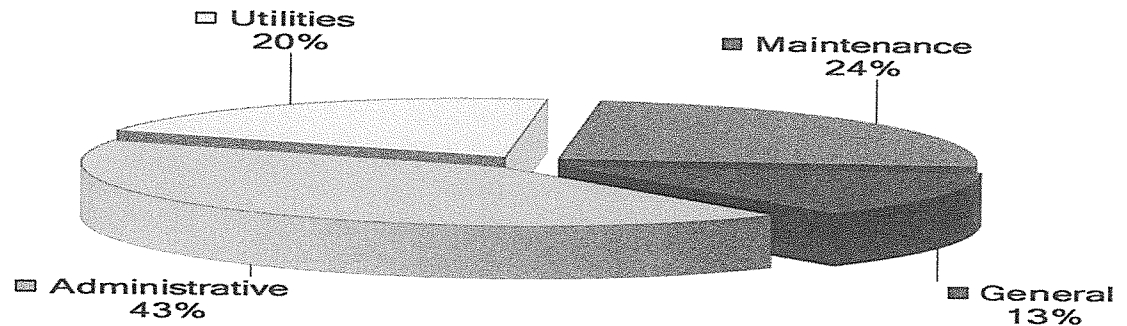

Analysis of Capital Asset Activity

Land, Buildings, Furniture, Equipment, & Machinery-Administration, Leasehold Improvements and Infrastructure remained the same. The Authority made upgrades to dwelling equipment.

Buildings increased by \$127,392 for grant years that closed and were transferred to public housing assets.

Leasehold Improvements increased by \$24,886 for improvements to the buildings, (ramps for handicap accessibility, walkway restorations, etc).

Accumulated Depreciation increased by \$65,772. This is the amount of depreciation expense recognized during the fiscal year.

HOUSING AUTHORITY OF THE CITY OF HUNTINGBURG
Huntingburg, Indiana

MANAGEMENT DISCUSSION AND ANALYSIS
December 31, 2020

	<u>2020</u>	<u>2019</u>	<u>Net Change</u>	<u>Percent Variance</u>
Land	\$ 14,750	\$ 14,750	\$ -	0.0%
Buildings	2,562,476	2,435,084	127,392	5.2%
Furniture, Equip., & Mach. - Dwelling	153,853	153,853	0	0.0%
Furniture, Equip., & Mach. - Administrative	205,218	205,218	0	0.0%
Leasehold Improvements	569,585	544,699	24,886	4.6%
Infrastructure	108,120	108,120	0	0.0%
Construction in Process	62,245	61,866	379	0.6%
Total Capital Assets	3,676,247	3,523,590	152,657	4.3%
Accumulated Depreciation	2,693,356	2,627,584	65,772	2.5%
Net Capital Assets	\$ 982,891	\$ 896,006	\$ 86,885	9.7%

More detailed information about the capital assets is presented in the Notes to the Financial Statements.

HOUSING AUTHORITY OF THE CITY OF HUNTINGBURG
Huntingburg, Indiana

MANAGEMENT DISCUSSION AND ANALYSIS

December 31, 2020

Budgetary Analysis

For the Year Ended December 31, 2020				
Tenant Revenue	\$ 182,000	\$ 200,666	\$ 18,666	10.26%
Federal Grants & Subsidy	154,614	177,603	22,989	14.87%
Investments	1,500	3,833	2,333	155.53%
Other Income	19,400	137,004	117,604	606.21%
Total Revenue	<u>357,514</u>	<u>519,106</u>	<u>161,592</u>	45.20%
Expenses:				
Administrative	138,388	108,658	(29,730)	-21.48%
Tenant Services	500	12,460	11,960	2392.00%
Utilities	68,200	63,697	(4,503)	-6.60%
Routine Maintenance	88,960	54,564	(34,396)	-38.66%
Protective Services	-	762	762	-100.00%
General	69,970	51,760	(18,210)	-26.03%
Total Expenses	<u>366,018</u>	<u>291,901</u>	<u>(74,117)</u>	-20.25%
Increase (decrease) in Net Position	<u>\$ (8,504)</u>	<u>\$ 227,205</u>	<u>\$ 235,709</u>	-2771.74%

A budget is a working Tool used to plan & track the income versus expenses of a PHA for a fiscal year. The HHA prepares the original budget prior to the beginning of the fiscal year and this budget remains for the entire year. Budget amounts are based on a combination of Prior year experience and any items anticipated in the upcoming year.

Revenue was more than what was budgeted this year due to an increase in Rental income, Tenants paying more for rent. And more CFP Operations funding in 2020, in addition to CARES Act monies received.

Expenses were less in 2020 due to the purchase of Security services equipment in 2019, and Maintenance materials and contracts decreasing from 2019.

**HOUSING AUTHORITY OF THE CITY OF HUNTINGBURG
Huntingburg, Indiana**

MANAGEMENT DISCUSSION AND ANALYSIS

December 31, 2020

BUDGETARY HIGHLIGHTS

For the Year Ended December 31, 2020, individual program or grant budgets were prepared by the Authority and were approved by the Board of Commissioners. The budgets were primarily used as a management tool and have no legal stature. (Also, the Authority adopted a comprehensive annual budget for the General Fund). The budgets were prepared in accordance with the accounting procedures prescribed by the applicable funding agency.

ECONOMIC FACTORS

Significant economic factors affecting the Authority are as follows:

Federal funding of the Department of Housing and Urban Development Local labor supply and demand, which can affect salary and wage rates Local inflationary, recessionary and employment trends, which can affect resident incomes and therefore the amount of rental income Inflationary pressure on utility rates, supplies and other cost Pandemic, tenants out of work, eviction moratorium.

FINANCIAL CONTACT

The individual to be contacted regarding this report is the Executive Director of the Huntingburg Housing Authority, Heidi Reller, at 1102 Friendship Village, Huntingburg IN. Telephone number (812)-683-2513.

FINANCIAL STATEMENTS

HOUSING AUTHORITY OF THE CITY OF HUNTINGBURG
Huntingburg, Indiana

STATEMENT OF NET POSITION
DECEMBER 31, 2020

ASSETS

CURRENT ASSETS

Cash and cash equivalents	\$ 378,410
Restricted cash and cash equivalents	10,867
Accounts receivable, net	2,950
Prepaid insurance	2,453
Inventory	14,113
	408,793
Total Current Assets	408,793

CAPITAL ASSETS

Land and other nondepreciable assets	76,995
Depreciable capital assets, net	905,896
	982,891
Total Capital Assets	982,891

Total Assets	1,391,684
---------------------	------------------

Deferred outflow of resources

Pension related	7,204
	7,204

Total Assets and Deferred Outflow of Resources	1,398,888
-------------------------------------------------------	------------------

CURRENT LIABILITIES

Accounts payable	6,778
Accrued liabilities	19,837
Payable from restricted cash and cash equivalents:	
Tenant's security deposits	10,867
Unearned revenue	5,220
	42,702
Total Current Liabilities	42,702

NONCURRENT LIABILITIES

Compensated absences	3,378
Net Pension Liability	28,694
	32,072
Total Noncurrent Liabilities	32,072

Total Liabilities	74,774
--------------------------	---------------

Deferred inflow of resources

Pension related	6,456
	6,456

NET POSITION

Investment in capital assets	982,891
Unrestricted	334,767
	1,317,658

TOTAL NET POSITION	\$ 1,317,658
---------------------------	---------------------

The accompanying notes are an integral part of these financial statements.

HOUSING AUTHORITY OF THE CITY OF HUNTINGBURG
Huntingburg, Indiana

STATEMENT OF REVENUES, EXPENSES AND CHANGES IN FUND NET POSITION
FOR THE YEAR ENDED DECEMBER 31, 2020

OPERATING REVENUES

Rental income	\$ 200,666
Other revenue	137,004

TOTAL OPERATING REVENUES	<u>337,670</u>
---------------------------------	-----------------------

OPERATING EXPENSES

Administrative	108,658
Tenant services	12,460
Utilities	63,697
Ordinary maintenance and operation	54,564
Protective services	762
General expense	51,760
Depreciation expense	65,772

TOTAL OPERATING EXPENSES	<u>357,673</u>
---------------------------------	-----------------------

OPERATING INCOME (LOSS)	<u>(20,003)</u>
-------------------------	-----------------

NONOPERATING REVENUES (EXPENSES)

Federal operating grants	115,358
Interest income	3,833

TOTAL NONOPERATING REVENUES	<u>119,191</u>
------------------------------------	-----------------------

CAPITAL CONTRIBUTIONS	62,245
-----------------------	--------

CHANGE IN NET POSITION	161,433
------------------------	---------

NET POSITION, BEGINNING OF YEAR	<u>1,156,225</u>
---------------------------------	------------------

NET POSITION, END OF YEAR	<u><u>\$ 1,317,658</u></u>
---------------------------	----------------------------

The accompanying notes are an integral part of these financial statements.

HOUSING AUTHORITY OF THE CITY OF HUNTINGBURG
Huntingburg, Indiana

STATEMENT OF CASH FLOWS
FOR THE YEAR ENDED DECEMBER 31, 2020

CASH FLOWS FROM OPERATING ACTIVITIES

Receipts from residents and other deposits	\$	197,928
Payments to suppliers		(203,280)
Payments to/for employees		<u>(83,257)</u>
 Net Cash Flows Provided (Used) by Operating Activities		 <u>50,019</u>

CASH FLOWS FROM INVESTING ACTIVITIES

Interest income		<u>3,833</u>
 Net Cash Provided by Investing Activities		 <u>3,833</u>

CASH FLOWS FROM CAPITAL AND RELATED FINANCING ACTIVITIES

Capital grants received		62,245
Mortgages received		(2,704)
Capital assets purchased		<u>(152,657)</u>
 Net Cash Provided (Used) from Capital and Related Financing Activities		 <u>(93,116)</u>

CASH FLOWS FROM NONCAPITAL FINANCING ACTIVITIES

Federal operating grants received		<u>115,358</u>
 Net Cash Flows Provided by Noncapital Financing Activities		 <u>115,358</u>

Net Increase (Decrease) in Cash and Cash Equivalents		76,094
 Cash - Beginning of year		 <u>313,183</u>
 Cash - End of year	\$	 <u><u>389,277</u></u>
 Reconciliation of Cash		
Unrestricted	\$	378,410
Restricted		<u>10,867</u>
	\$	<u><u>389,277</u></u>

Continued

HOUSING AUTHORITY OF THE CITY OF HUNTINGBURG
Huntingburg, Indiana

STATEMENT OF CASH FLOWS
FOR THE YEAR ENDED DECEMBER 31, 2020
(CONTINUED)

RECONCILIATION OF OPERATING INCOME TO
NET CASH PROVIDED BY OPERATING ACTIVITIES

Operating income (loss)	\$	(20,003)
Adjustments to reconcile net operating income (loss) to net cash Provided by operating activities:		
Depreciation		65,772
(Increase) Decrease in:		
Accounts receivable		2,738
Prepaid expenses		(83)
Inventory		(2,182)
Increase (Decrease) in:		
Accounts payable		4,624
Accrued liabilities		668
Pension related		(4,520)
Unearned revenue		3,005
		<hr/>
Net Cash Flows Provided (Used) by Operating Activities	\$	<u>50,019</u>

The accompanying notes are an integral part of these financial statements.

HOUSING AUTHORITY OF THE CITY OF HUNTINGBURG
Huntingburg, Indiana

NOTES TO FINANCIAL STATEMENTS
DECEMBER 31, 2020

NOTE A - Summary of Significant Accounting Policies and Organization:

The financial statements of the HOUSING AUTHORITY OF THE CITY OF HUNTINGBURG ("the Authority") have been prepared in conformity with generally accepted accounting principles (GAAP) as applied to government units. The Government Accounting Standards Board (GASB) is the accepted standard-setting body for establishing governmental accounting and financial reporting principles.

Reporting Entity - The entity is a public corporation, legally separate, fiscally independent, and governed by the Board of commissioners. As required by generally accepted accounting principles, these financial statements present the financial position and results of operations of the Housing Authority of the City of Huntingburg. There are no component units to be included herewith, but this report does include all programs which are controlled by the entity's governing body.

The financial statements of the Housing Authority of the City of Huntingburg include the following:

At December 31, 2019, the Housing Authority has 50 units under management.

<u>Project</u>	<u>Units</u>
Low Income Public Housing	50

The Authority is also operating Capital Fund Grant Programs.

Basis of Presentation and Accounting: In accordance with uniform financial reporting standards for HUD housing programs, the financial statements are prepared in accordance with U.S. generally accepted accounting principles (GAAP) as applicable to special purpose governments engaged only in business type activities.

Proprietary funds are accounted for using the "economic resources" measurement focus and the accrual basis of accounting. Accordingly, all assets, deferred outflow of resources, liabilities, and deferred inflow of resources are included in the Statement of Net Position. The Statement of Revenues, Expenses and Changes in Fund Net Position present increases (revenues) and decreases (expenses) in net position. Under the Accrual basis of accounting, revenues are recognized in the period in which they are earned while expenses are recognized in the period in which the liability is incurred.

This special purpose government engaged in activities similar to business activities uses an enterprise fund to account for those operations that are financed and operated in a manner similar to private business, or where the Board has decided that the determination of revenues earned, costs incurred, and/or net income is necessary for management accountability. The intent of the governing body is that the costs (expenses including depreciation) of providing services to the general public on a continuing basis be financed or recovered primarily through user charges.

Generally accepted accounting principles for state and local governments requires that resources be classified for accounting and reporting purposes into the following net position categories:

HOUSING AUTHORITY OF THE CITY OF HUNTINGBURG
Huntingburg, Indiana

NOTES TO FINANCIAL STATEMENTS

DECEMBER 31, 2020

(Continued)

NOTE A - Summary of Significant Accounting Policies and Organization: (Continued)

Investment in Capital Assets: Capital assets, net of accumulated depreciation and outstanding principal balances of debt attributable to the acquisition, construction or improvement of those assets.

Restricted: Net position whose use by the Authority is subject to externally imposed stipulations that can be fulfilled by actions of the Authority pursuant to those stipulations or that expire by the passage of time. Such assets include assets restricted for capital acquisitions and debt service.

Unrestricted: Net position that are not subject to externally imposed stipulations. Unrestricted net position may be designated for specific purposes by action of management or the Authority Board or may otherwise be limited by contractual agreements with outside parties.

Budgets - Budgets are prepared on an annual basis for each major operating program and are used as a management tool throughout the accounting cycle. The capital fund budgets are adopted on a "project length" basis.

Budget compared to actual presentation is not presented because the Authority does not annually adopt a legally authorized budget. The authority's budget is adopted by the Authority's board and approved by HUD. This budget does not represent a legally binding appropriated budget that has been signed into law or a non-appropriated budget authorized by constitution. The Authority's budget represents budgetary execution and management by its board and HUD; therefore, budgetary data and presentation is not required.

Cash and Cash Equivalents - Deposits consist of checking accounts, Money Market accounts and Certificates of deposit and are stated at fair value. Deposits are fully collateralized or vested in securities of the United States Government and are identified specifically in the name of the Authority.

For the purposes of the Statement of Cash Flows, the Authority considers all highly liquid cash deposits and cash equivalents with a maturity of three months or less when purchases and non-negotiable Certificates of Deposit to be cash equivalents. There were no noncash investing, capital, and financing activities during the year.

State statutes authorize the Housing Authority to invest in securities including, but not limited to, federal government securities, repurchase agreements, and certain money market mutual funds. Certain other statutory restrictions apply to all investments made by political subdivisions.

Tenant Receivable - Receivable for rentals and service charges are reported as net of an allowance for doubtful accounts. The Authority board takes monthly action as required to write off specific uncollectible accounts receivable balances.

Prepaid - Prepaid represent payments made to vendors for services that will benefit beyond December 31, 2020

Inventories - Inventories are valued at cost, which approximates market value, using the first-in/first-out (FIFO) method. The consumption method is applied and expense is charged when inventory items are used for the units.

HOUSING AUTHORITY OF THE CITY OF HUNTINGBURG
Huntingburg, Indiana

NOTES TO FINANCIAL STATEMENTS
DECEMBER 31, 2020
(Continued)

NOTE A - Summary of Significant Accounting Policies and Organization: (Continued)

Capital assets - Capital assets purchased are recorded on the Statement of Net Position at the time of purchase. Such assets are recorded at cost. The capitalization policy of the Authority requires assets to be capitalized when their cost is \$1,500 or more. Donated assets are recorded at fair market value at the date of donation. Because developments and major capital repairs or improvements are financed through cash advances from HUD, there are no capitalized interest costs in current programs.

Depreciation of capital assets is computed by the straight-line method based upon the estimated useful lives of the assets as follows:

<u>Class</u>	<u>Life</u>
Buildings and improvements	15-40 years
Maintenance and office equipment	3-7 years

Compensated Absences - compensated absences are those absences for which employees will be paid, such as vacation and sick leave. A liability for compensated absences that is attributable to services already rendered and that are not contingent on a specific event that is outside the control of the Authority and its employees, is accrued as employees earn the rights to the benefits. Compensated absences that related to future services or that are contingent on a specific event that is outside the control of the Authority and its employees are accounted for in the period in which such services are rendered or in which such events take place.

Operating Revenues and Expenses - Operating revenues and expenses generally result from providing and producing goods and/or services in connection with providing low income housing programs. Operating expenses include the costs of sales and services, administrative expenses and depreciation on capital assets. All revenues and expenses not meeting this definition are reported as non-operating revenues and expenses.

Restricted Assets - When both restricted (if any) and unrestricted resources are available for use, it is the Authorities policy to use unrestricted resources first, and then restricted resources as they are needed.

Use of Estimates - The preparation of financial statements in conformity with accounting principles generally accepted in the United States of America requires management to make estimates and assumptions that affect the reported amounts of assets and liability and disclosure of contingent liability at the date of the financial statements and report amounts of revenues and expenses during the reporting period. Actual results could differ from those estimates.

Leasing Activities (as Lessor) - The Authority is the lessor of dwelling units primarily to low-income residents. The rents under the leases are determined generally by the resident's income as adjusted for eligible deductions regulated by HUD, although the resident may opt for a flat rent. Leases may be cancelled by the lessee at any time. The Authority may cancel the lease only for cause.

Revenues associated with these leases are recorded in the financial statements and scheduled as "Rental income". Rental income per resident generally remains consistent from year to year, but is affected by general economic conditions which impact personal income, such as local job availability.

HOUSING AUTHORITY OF THE CITY OF HUNTINGBURG
Huntingburg, Indiana

NOTES TO FINANCIAL STATEMENTS

DECEMBER 31, 2020

(Continued)

NOTE B - Deposits, Cash and Cash Equivalents:

1. HUD Deposit Restrictions

HUD requires Authorities to invest excess HUD program funds in obligations of the United States, certificates of deposit or any other federally insured instruments. HUD also requires that deposits of HUD program funds be fully insured or collateralized at all times. Acceptable security includes FDIC/FSLIC insurance and the market value of securities purchased and pledged to the political subdivision. Pursuant to HUD restrictions, obligations of the United States are allowed as security for deposits. Obligations furnished as security must be held by the Authority or with an unaffiliated bank or trust company for the account of the Authority.

Deposits, made in accordance with State statute (IC 5-13), with financial institutions in the State of Indiana should be covered to the extent not covered by insurance of any Federal deposit insurance agency.

2. Risk Disclosures

A. Interest Rate Risk: As a means of limiting its exposure to fair value losses arising from rising interest rates, the Authority's investment policy limits the Authority's investment portfolio to maturities not to exceed two years at time of purchase. At December 31, 2020, the Authority's deposits and investments were not limited and all of which are either available on demand or have maturities of less than two years.

B. Credit Risk: This is a risk that a security or a portfolio will lose some or all of its value due to a real or perceived change in the ability of the issuer to repay its debt. The Authority's investment policy is that none of its total portfolio may be invested in securities of any single issuer, other than the US Government, its agencies and instrumentalities.

C. Custodial Credit Risk: This is the risk that in the event of the failure of the counterparty, the Authority will not be able to recover the value of its investments or collateral securities that are held by the counterparty. All of the Authority's investments in securities are held in the name of the Authority. The Authority's custodial agreement policy prohibits counterparties holding securities not in the Authority's name.

Deposits made in accordance with state statute (Indiana Code 5-13) with financial institutions in the State of Indiana should be covered to the extent not covered by insurance of any federal deposit insurance agency.

At December 31, 2020 the carrying amount of the Authority's deposits was \$389,277 and the bank balance was \$457,001. The deposits are either covered by federal depository insurance, by collateral held by the Authority's agent in the Authority's name or by the Federal Reserve Banks acting as third party agents or by a collateralization agreement. Restricted cash consists of tenant security deposits.

HOUSING AUTHORITY OF THE CITY OF HUNTINGBURG
Huntingburg, Indiana

NOTES TO FINANCIAL STATEMENTS
DECEMBER 31, 2020

NOTE B - Deposits, Cash and Cash Equivalents: (Continued)

Deposits consist of the following:

Checking accounts, Money Market Account, Savings and Certificate Of Deposit	<u>\$ 389,277</u>
-----------------------------------------------------------------------------	-------------------

NOTE C - Accounts Receivable:

Accounts receivable at December 31, 2020, consist of the following:

Tenants, Net of allowance of \$2,030	\$ 2,308
Accrued Receivable	<u>642</u>
Total	<u>\$ 2,950</u>

NOTE D - Prepaid Expense:

Prepaid expenses at December 31, 2020, consists of the following:

Prepaid insurance and other expenses	<u>\$ 2,453</u>
--------------------------------------	-----------------

NOTE E - Inventory:

Inventory at December 31, 2020, consists of the following:

Materials and supplies	<u>\$ 14,113</u>
------------------------	------------------

Materials inventories are recorded at cost. The FIFO inventory flow assumption is used to determine expenditures. Expenditures are recorded when inventory is consumed.

NOTE F - Capital Assets:

	Beginning Balance 12/31/19	Increases	Decreases	Transfers	Ending Balance 12/31/20
Capital assets, not being depreciated:					
Land	\$ 14,750	\$ 0	\$ 0	\$ 0	\$ 14,750
Construction in Progress	0	62,245	0	0	62,245
Total Capital Assets, Not being depreciated	14,750	62,245	0	0	76,995
Capital Assets, being depreciated:					
Buildings & Improvements	3,087,903	214,523	0	0	3,302,426
Furniture, Equipment & Machinery	359,071	0	0	0	359,071
Total Capital Assets, being depreciated	3,446,974	214,523	0	0	3,661,497

HOUSING AUTHORITY OF THE CITY OF HUNTINGBURG
Huntingburg, Indiana

NOTES TO FINANCIAL STATEMENTS
DECEMBER 31, 2020

NOTE F - Capital Assets:

Less Accumulated Depreciation for:					
Buildings & Improvements	(2,296,609)	(62,581)	0	0	(2,359,190)
Furniture, Equipment and Machinery	<u>(330,975)</u>	<u>(3,191)</u>	<u>0</u>	<u>0</u>	<u>(334,166)</u>
Total Accumulated Depreciation:	<u>(2,627,584)</u>	<u>(65,772)</u>	<u>0</u>	<u>0</u>	<u>(2,693,356)</u>
Total Capital Assets, being depreciated, net	<u>818,390</u>	<u>149,751</u>	<u>0</u>	<u>0</u>	<u>968,141</u>
Capital Assets, Net	<u>\$ 833,140</u>	<u>\$ 149,751</u>	<u>\$ 0</u>	<u>\$ 0</u>	<u>\$ 982,891</u>

Depreciation expense for the year ended December 31, 2020, was \$65,772.

NOTE G - Pension Plan:

Plan Description - The Housing Authority participates in a cost-sharing multiple-employer pension plan, as defined in Governmental Accounting Standards Board Statement No, 67, *Financial Reporting for Pension Plans*. The pension plan is administered by the Indiana Public Retirement Systems (INPRS) and is based on Title 35 of IAC 21-1-1, 35 IAC 21-1-2 and amended IC 5-10.2-2-11(b). The Public Employees' Retirement Fund (PERF) Hybrid Plan was established by the Indiana Legislature in 1945 and is governed by the INPRS Board of Trustees. INPRS financial reports are available online at <https://www.in.gov/inprs/actuarialvaluation.htm>.

Members include officers and employees of the units of State and local governments in Indiana (referred to as political subdivisions), including counties, cities, towns, townships, libraries, and school corporations. The political subdivisions become participants by resolution of the governing body, which specifies the classifications of employees who will become members of the PERF Hybrid plan.

Benefits Provided - Retirement benefits consist of a defined pension benefit provided by employer contributions plus the amount credited to the member's annuity savings account. Pension benefits vest after 10 years of creditable service. At retirement, a member may choose to receive a lump sum payment of the amount credited to the member's annuity savings account.

A member who has reached age 65 and has at least 10 years of creditable service is eligible for normal retirement and, as such, is entitled to 100% of the pension benefit component. This annual pension benefit is equal to 1.1 percent times the average annual compensation times the number of years of creditable service. The average annual compensation in this calculation uses the highest 20 calendar quarters of salary in a covered position.

A member who has reached age 60 and has at least 15 years of creditable service is eligible for normal retirement and, as such, is entitled to 100% of the pension benefit.

A member who is at least 55 years old with sum of age and vesting service equal to 85 or more is eligible for normal retirement and, as such, is entitled to 100% of the pension benefit

In lieu of a cost of living adjustment (COLA) on January 1, 2020, members in the plan were provided a 13th check on October 1, 2020.

HOUSING AUTHORITY OF THE CITY OF HUNTINGBURG
Huntingburg, Indiana

NOTES TO FINANCIAL STATEMENTS
DECEMBER 31, 2020

NOTE G- Pension Plan: (Continued)

The PERF hybrid plan also provides disability and survivor benefits.

Contributions - Members are required by statute to make contributions to the plan as determined by the INPRS Board of Trustees based on actuarial investigation and valuation in accordance with IC 5-10.2-2-11. During 2020, all participating employers contributed an average of 11.0% of covered payroll. The authority's required contribution to the plan for the fiscal year ended December 31, 2020 was \$5,726. A contribution of 3% of covered payroll was contributed by the employees into the annuity savings account portion.

Pension Liabilities, Pension Expense, and Deferred Outflows of Resources and Deferred Inflows of Resources Related to Pensions

At December 31 2020, the Housing Authority reported a liability of \$28,694 for its proportionate share of the net pension liability. The net pension liability was measured as of June 30, 2020, and the total pension liability used to calculate the net pension liability was determined by an actuarial valuation as of June 30, 2019 rolled forward to June 30, 2020. No material changes in assumptions or benefit terms occurred between the actuarial valuation date and the measurement date. The Housing Authority's proportion of the net pension liability was based on the Housing Authority's share of contributions to the pension plan relative to the contributions of all participating employers. At June 30, 2020, the Housing Authority's proportion was 0.0000095%, which remained the same as measured as of June 30, 2019

There was \$7,204 reported as deferred outflows related to pension resulting from the INPRS Employer's contributions subsequent to the measurement date. Other amounts reported as deferred outflows of resources and deferred inflows of resources related to pension will be recognized in pension expense as follows:

HOUSING AUTHORITY OF THE CITY OF HUNTINGBURG
Huntingburg, Indiana

NOTES TO FINANCIAL STATEMENTS
DECEMBER 31, 2020

NOTE G- Pension Plan: (Continued)

Actuarial Assumptions - The total pension liability in the June 30, 2020, actuarial valuation was determined using the following actuarial assumptions, applied to all periods included in the measurement:

Actuarial Valuation Date:	June 30, 2020
Measurement Date of Net Pension Liability	June 30, 2020
Actuarial Cost Method:	Entry Age Normal - Level Percent of Payroll
Asset Valuation Method:	Fair Market Value
Long-Term Expected Rate of Return:	6.75%
Discount Rate:	6.75%, net of investment expenses
Salary Increases:	
Inflation	2.25%
Productive, Merit, and Promotion	0.25-2.00%
Mortality:	RP-2014 (with MP-2014 improvement removed) Total Data Set Mortality Tables projected on a fully generational basis using the future mortality improvement scale inherent in the mortality projection included in the Social Security Administration's 2014 Report.

Actuarial assumptions are based upon an experience study completed in April 2015 using experience between June 30, 2010 and June 30, 2014. The demographic assumptions were updated as needed for the June 30, 2015 actuarial valuation based on the results of the study. The total pension liability for June 30, 2019 is based upon a roll-forward of the liability calculated from the June 30, 2018 actuarial valuation.

Long-Term Expected Return on Plan Assets - The long-term expected rate of return on pension plan investments was determined using a building-block method in which best-estimate ranges of expected future real rates of return (expected returns, net of pension plan investment expense and inflation) are developed for each major asset class. These ranges are combined to produce the long-term expected rate of return by weighting the expected future real rates of return by the target asset allocation percentage and by adding expected inflation. The target allocation and best estimates of arithmetic real rates of return for each major asset class are summarized in the following table:

HOUSING AUTHORITY OF THE CITY OF HUNTINGBURG
Huntingburg, Indiana

NOTES TO FINANCIAL STATEMENTS
DECEMBER 31, 2020

NOTE G- Pension Plan: (Continued)

Asset Allocation Targets and Expected Returns (as of June 30, 2020)

<u>Asset Class</u>	Current Asset Allocation %	Target Range %
Public Equity	21.8	22.0
Private Markets	12.2	14.0
Fixed Income-Ex Inflation-Linked	19.4	20.0
Fixed Income-Inflation-Linked	7.3	7.0
Commodities	6.6	8.0
Real Estate	6.8	7.0
Absolute Return	10.6	10.0
Risk Party	13.4	12.0
Cash + Cash Overlay	1.9	N/A
Total	100%	100%

Single Discount Rate - The discount rate used to measure the total pension liability was 6.75% and is equal to long-term expected return on plan investments, net of administrative expenses. The INPRS Board of Trustees has established a funding policy of setting the employer contribution rate equal to the greater of: 1) the current contribution rate of 11.2%, or 2) the actuarially determined contribution rate computer by the actuary using the assumptions and methods selected by the Board for the annual actuarial valuations.

Sensitivity of the Housing Authority's Proportionate Share of the Net Pension Liability to Changes in the Discount Rate - The following presents the Housing Authority's proportionate share of the net pension liability calculated using the discount rate of 6.75 percent, as well as what the Housing Authority's proportionate share of the net pension liability would be if it were calculated using a discount rate that is 1-percentage-point lower (5.75 percent) or 1-percentage-point higher (7.75 percent) than the current rate:

Decrease (5.75%)	Discount rate (6.75%)	1% Increase (7.75%)
\$46,781	\$28,694	\$13,545

HOUSING AUTHORITY OF THE CITY OF HUNTINGBURG
Huntingburg, Indiana

NOTES TO FINANCIAL STATEMENTS
DECEMBER 31, 2020

NOTE G- Pension Plan: (Continued)

Pension Expense

For the year ended December 31, 2020, the Housing Authority recognized pension expense of \$2,492 which includes the changes in the collective net pension liability, projected earnings on pension plan investments, and the amortization of deferred outflows of resources and deferred inflows of resources for the current period.

Deferred Outflows of Resources and Deferred Inflows of Resources

	Deferred outflows of resources	Deferred inflows of resources
Differences between actual and expected experience	\$508	\$385
Net differences between projected and actual investment earnings on pension plan investments	2,456	0
Change of assumptions	0	5,979
Changes in proportion and differences between employer contributions and proportionate share of contributions	250	92
Total	\$3,214	\$6,456

Amounts reported as deferred outflows of resources and deferred inflows of resources related to pensions will be recognized as a reduction of the NPL in the following years:

Amortization of net deferred outflows/(inflows) of resources - debit/(credit)	
2021	\$(2,846)
2022	(984)
2023	(455)
2024	1043
Thereafter	0
Total	\$(3,242)

The pension information has not been audited.

HOUSING AUTHORITY OF THE CITY OF HUNTINGBURG
Huntingburg, Indiana

NOTES TO FINANCIAL STATEMENTS
DECEMBER 31, 2020
(Continued)

NOTE H - Accounts Payable:

Accounts payable at December 31, 2020, consist of the following:

Vendor Accounts Payable	<u>\$ 6,778</u>
-------------------------	-----------------

NOTE I - Accrued Liabilities:

Accrued liabilities at December 31, 2020, consist of the following:

Payment in lieu of taxes	\$ 11,294
Accrued Wages	1,344
Accrued compensated absences	375
Accrued Other	<u>6,824</u>
 Total	 <u>\$ 19,837</u>

NOTE J - Unearned Revenue:

Unearned revenue at December 31, 2020, consists of the following:

Prepaid Rent	<u>\$ 5,220</u>
--------------	-----------------

NOTE K - Noncurrent Liabilities:

Noncurrent liabilities at December 31, 2020, consist of the following:

	<u>12/31/19</u>	<u>Additions</u>	<u>Deletions</u>	<u>12/31/20</u>	<u>Due within one year</u>	<u>Total due</u>
Accrued compensated absences	\$ 3,866	\$ 0	\$ 488	\$ 3,378	\$ 375	\$ 3,753
Net pension liability	<u>31,398</u>	<u>0</u>	<u>2,704</u>	<u>28,694</u>	<u>0</u>	<u>28,694</u>
 Total	 <u>\$ 35,264</u>	 <u>\$ 0</u>	 <u>\$ 3,192</u>	 <u>\$ 32,072</u>	 <u>\$ 375</u>	 <u>\$ 35,447</u>

HOUSING AUTHORITY OF THE CITY OF HUNTINGBURG
Huntingburg, Indiana

NOTES TO FINANCIAL STATEMENTS
DECEMBER 31, 2020
(Continued)

NOTE L - Federal Operating Grants:

HUD contributed the following operating subsidies approved in the operating budgets under the Annual Contributions Contracts:

LIPH CARES Funding	\$ 11,119
Low Rent Public Housing	72,365
Capital Fund Program	<u>31,874</u>
Total	<u>\$ 115,358</u>

NOTE M - Capital Contributions:

The Authority receives capital grants from HUD for capital fund program improvements. Capital contributions for the fiscal year ended December 31, 2020 were \$62,245.

NOTE N - Commitments and Contingencies:

Litigation: At December 31, 2020, the Authority was not involved in any threatened litigation.

Examination: The Authority is subject to possible examinations made by Federal and State authorities who determine compliance with terms, conditions, law and regulations governing other grants given to the Authority in the current and prior years. There were no examinations during the year ended December 31, 2020.

Grant Disallowances: Amounts received or receivable from HUD are subject to audit and adjustment by HUD. Any disallowed claims, including amounts already collected, would constitute a liability of the Authority. The amounts, if any, of expenses which may be disallowed by the grantor cannot be determined at this time although the Authority expects such amounts, if any, to be immaterial.

Construction Projects: There is one major construction project in progress at December 31, 2020. The Authority spends capital funds on the rental units at the project sites. These expenditures are being funded by HUD. Funds are requested periodically as the cost is incurred.

NOTE O - Risk Management:

The Authority is exposed to various risks of losses related to torts; theft of, damage to and destruction of assets; errors and omissions; injuries to employees; and natural disasters. The Authority carries commercial insurance coverage for these risks to the extent deemed prudent by Authority management. Settled claims have not exceeded this commercial coverage in any of the past 3 years.

NOTE P - Economic Dependency:

The Authority receives approximately 52% of its operating revenues from HUD. If the amount of revenues received from HUD falls below critical levels, the Authority's operations could be adversely affected.

HOUSING AUTHORITY OF THE CITY OF HUNTINGBURG
Huntingburg, Indiana

NOTES TO FINANCIAL STATEMENTS
DECEMBER 31, 2020
(Continued)

NOTE Q - Conduit Type Debt:

Debt related to the original acquisition and early modernization of the public housing development is funded, guaranteed, and serviced by HUD. There is no debt or pledge of faith and credit on the part of the Authority. Accordingly, this debt has not been recorded in the financial statements of the Authority.

NOTE R - Subsequent Events:

Events that occur after the balance sheet date but before the financial statements were available to be issued must be evaluated for recognition or disclosure. The effects of subsequent events that provide evidence about conditions that existed at the balance sheet date are recognized in the accompanying financial statements. Subsequent events which provide evidence about conditions that existed after the balance sheet date require disclosure in the accompanying notes. Management has evaluated the activity of the Authority through September 10, 2021 (the date the financial statements were available to be issued) and concluded that no subsequent events have occurred that would require recognition in the financial statements or disclosure in the notes to the financial statements.

REQUIRED SUPPLEMENTARY INFORMATION

HOUSING AUTHORITY OF THE CITY OF HUNTINGBURG
Huntingburg, Indiana

REQUIRED SUPPLEMENTARY INFORMATION

Schedule of the Authority's Proportionate Share of the Net Pension Liability

INPRS Pension Plan
Last Ten Fiscal Years*

	<u>2016</u>	<u>2017</u>	<u>2018</u>	<u>2019</u>	<u>2020</u>
Housing Authority of the City of Huntingburg proportionate share of the net pension liability	.0000082	.0000095	.0000094	.0000095	.0000095
Housing Authority of the City of Huntingburg proportionate share of the net pension liability	\$ 37,215	\$ 42,385	\$ 31,932	\$ 31,398	\$28,694
Housing Authority of the City of Huntingburg covered employee payroll	\$ 39,985	\$ 46,957	\$ 48,188	\$ 50,395	\$51,121
Housing Authority of the City of Huntingburg proportionate share of the net pension liability as a percentage of it's covered employee payroll	.930724	.902634	.662654	.623038	.561200

Note: Additional years information will be presented when available.

* The amounts for each fiscal year were determined as of 6/30.

HOUSING AUTHORITY OF THE CITY OF HUNTINGBURG
Huntingburg, Indiana

REQUIRED SUPPLEMENTARY INFORMATION

SCHEDULE OF THE HOUSING AUTHORITY OF THE CITY OF HUNTINGBURG CONTRIBUTIONS

INPRS Pension Plan
Last Ten Fiscal Years*

	<u>2016</u>	<u>2017</u>	<u>2018</u>	<u>2019</u>	<u>2020</u>
Contractually required contribution	\$ 4,413	\$ 5,259	\$ 5,397	\$ 5,552	\$ 5,726
Contributions in relation to the contractually required contribution	<u>\$ 4,413</u>	<u>\$ 5,259</u>	<u>\$ 5,397</u>	<u>\$ 5,552</u>	<u>\$ 5,726</u>
Contribution deficiency (excess)	<u>\$ 0</u>	<u>\$ 0</u>	<u>\$ 0</u>	<u>\$ 0</u>	<u>\$ 0</u>
Housing Authority of the City of Huntingburg covered employee payroll	\$ 3,985	\$46,957	\$48,188	\$50,395	\$51,121
Contributions as a percentage of covered employee payroll	11.0%	11.0%	11.0%	11.0%	11.0%

Note: Additional years information will be presented when available.

* The amounts for each fiscal year were determined as of 6/30.

SUPPLEMENTAL FINANCIAL INFORMATION

HOUSING AUTHORITY OF THE CITY OF HUNTINGBURG
Huntingburg, Indiana

COMBINING SCHEDULE OF PROGRAM NET POSITION

DECEMBER 31, 2020

	A C C		
	C-543	C-543	Total
	Low Income Public Housing & Cares Act	Capital Fund Programs	
<u>ASSETS</u>			
<u>CURRENT ASSETS</u>			
Cash and cash equivalents	\$ 378,410	\$ 0	\$ 378,410
Restricted cash and cash equivalents	10,867	0	10,867
Accounts receivable, net	2,950	0	2,950
Prepaid insurance	2,453	0	2,453
Inventory	14,113	0	14,113
Total Current Assets	408,793	0	408,793
<u>CAPITAL ASSETS</u>			
Land and other nondepreciable assets	76,995	0	76,995
Depreciable capital assets, net	905,896	0	905,896
Total Capital Assets	982,891	0	982,891
Total Assets	1,391,684	0	1,391,684
<u>Deferred outflow of resources</u>			
Pension related	7,204	0	7,204
Total Assets and Deferred Outflow of Resources	1,398,888	0	1,398,888
<u>LIABILITIES</u>			
<u>CURRENT LIABILITIES</u>			
Accounts payable	6,778	0	6,778
Accrued liabilities	19,837	0	19,837
Payable from restricted cash and cash equivalents:			
Tenant's security deposits	10,867	0	10,867
Unearned revenue	5,220	0	5,220
Total Current Liabilities	42,702	0	42,702
<u>NONCURRENT LIABILITIES</u>			
Compensated absences	3,378	0	3,378
Net pension liability	28,694	0	28,694
Total Noncurrent Liabilities	32,072	0	32,072
Total Liabilities	74,774	0	74,774
<u>Deferred inflow of resources</u>			
Pension related	6,456	0	6,456
<u>NET POSITION</u>			
Investment in capital assets	982,891	0	982,891
Unrestricted	334,767	0	334,767
TOTAL NET POSITION	\$ 1,317,658	\$ 0	\$ 1,317,658

HOUSING AUTHORITY OF THE CITY OF HUNTINGBURG
Huntingburg, Indiana

COMBINING SCHEDULE OF PROGRAM REVENUES, EXPENSES AND CHANGES IN FUND NET POSITION
FOR THE YEAR ENDED DECEMBER 31, 2020

	C-543	C-543	
	Low Income Public Housing & Cares Act	Capital Fund Programs	Total
<u>OPERATING REVENUES</u>			
Rental income	\$ 200,666	\$ 0	\$ 200,666
Other revenue	137,004	0	137,004
TOTAL OPERATING REVENUES	337,670	0	337,670
<u>OPERATING EXPENSES</u>			
Administrative	108,658	0	108,658
Tenant Services	12,460	0	12,460
Utilities	63,697	0	63,697
Ordinary maintenance and operation	54,564	0	54,564
Protective services	762	0	762
General expense	51,760	0	51,760
Depreciation expense	65,772	0	65,772
TOTAL OPERATING EXPENSES	357,673	0	357,673
OPERATING INCOME (LOSS)	(20,003)	0	(20,003)
<u>NONOPERATING REVENUES (EXPENSES)</u>			
Federal operating grants	78,650	36,708	115,358
Interest income	3,833	0	3,833
TOTAL NONOPERATING REVENUES	82,483	36,708	119,191
CAPITAL CONTRIBUTIONS	0	62,245	62,245
CHANGE IN NET POSITION	62,480	98,953	161,433
NET POSITION, BEGINNING OF YEAR, as originally stated	1,156,225	0	1,156,225
Equity transfers	98,953	(98,953)	0
NET POSITION, BEGINNING OF YEAR, as restated	1,255,178	(98,953)	1,156,225
NET POSITION, END OF YEAR	\$ 1,317,658	\$ 0	\$ 1,317,658

HOUSING AUTHORITY OF THE CITY OF HUNTINGBURG
Huntingburg, Indiana

STATEMENT AND CERTIFICATION OF ACTUAL CAPITAL FUND GRANT COSTS - COMPLETED
DECEMBER 31, 2020

Annual Contributions Contract C-543

501-19

1. The Capital Fund Grant Costs are as follows:

Funds Approved	\$	92,578
Funds Expended		<u>92,578</u>
Excess / (Deficiency) of Funds Approved	\$	<u><u>0</u></u>
Funds Advanced	\$	92,578
Funds Expended		<u>92,578</u>
Excess / (Deficiency) of Funds Advanced	\$	<u><u>0</u></u>

- Costs additions totaling \$ 21,712 were made during the current audit period and, accordingly, were audited by Goldie Roberts, CPA.
- The total amount of the Capital Fund Grant Costs at December 31, 2020 as shown above are in agreement with the Actual Development Cost Certificate submitted to HUD and approved by HUD.
- All Capital Fund Grant work in connection with the Project has been completed.
- All liabilities have been paid and there are no undischarged liens against the Project on file in any public office where the same should be filed in order to be valid and the time in which such liens could be filed has expired.
- There were no budget overruns.

Housing Authority of the City of Huntingburg (IN028)
HUNTINGBURG, IN
Entity Wide Balance Sheet Summary

Submission Type: Audited/Single Audit

Fiscal Year End: 12/31/2020

	Project Total	14.PHC Public Housing CARES Act Funding	Subtotal	Total
111 Cash - Unrestricted	\$378,410		\$378,410	\$378,410
112 Cash - Restricted - Modernization and Development				
113 Cash - Other Restricted				
114 Cash - Tenant Security Deposits	\$10,867		\$10,867	\$10,867
115 Cash - Restricted for Payment of Current Liabilities				
100 Total Cash	\$389,277	\$0	\$389,277	\$389,277
121 Accounts Receivable - PHA Projects				
122 Accounts Receivable - HUD Other Projects				
124 Accounts Receivable - Other Government				
125 Accounts Receivable - Miscellaneous				
126 Accounts Receivable - Tenants	\$4,338		\$4,338	\$4,338
126.1 Allowance for Doubtful Accounts - Tenants	-\$2,030		-\$2,030	-\$2,030
126.2 Allowance for Doubtful Accounts - Other				
127 Notes, Loans, & Mortgages Receivable - Current				
128 Fraud Recovery				
128.1 Allowance for Doubtful Accounts - Fraud				
129 Accrued Interest Receivable	\$642		\$642	\$642
120 Total Receivables, Net of Allowances for Doubtful Accounts	\$2,950	\$0	\$2,950	\$2,950
131 Investments - Unrestricted				
132 Investments - Restricted				
135 Investments - Restricted for Payment of Current Liability				
142 Prepaid Expenses and Other Assets	\$2,453		\$2,453	\$2,453
143 Inventories	\$14,113		\$14,113	\$14,113
143.1 Allowance for Obsolete Inventories	\$0		\$0	\$0
144 Inter Program Due From				
145 Assets Held for Sale				
150 Total Current Assets	\$408,793	\$0	\$408,793	\$408,793
161 Land	\$14,750		\$14,750	\$14,750
162 Buildings	\$2,562,476		\$2,562,476	\$2,562,476
163 Furniture, Equipment & Machinery - Dwellings	\$153,853		\$153,853	\$153,853
164 Furniture, Equipment & Machinery - Administration	\$205,218		\$205,218	\$205,218
165 Leasehold Improvements	\$569,585		\$569,585	\$569,585
166 Accumulated Depreciation	-\$2,693,356		-\$2,693,356	-\$2,693,356
167 Construction in Progress	\$62,245		\$62,245	\$62,245
168 Infrastructure	\$108,120		\$108,120	\$108,120
160 Total Capital Assets, Net of Accumulated Depreciation	\$982,891	\$0	\$982,891	\$982,891
171 Notes, Loans and Mortgages Receivable - Non-Current				
172 Notes, Loans, & Mortgages Receivable - Non Current - Past Due				
173 Grants Receivable - Non Current				
174 Other Assets				
176 Investments in Joint Ventures				
180 Total Non-Current Assets	\$982,891	\$0	\$982,891	\$982,891
200 Deferred Outflow of Resources	\$7,204		\$7,204	\$7,204
290 Total Assets and Deferred Outflow of Resources	\$1,398,888	\$0	\$1,398,888	\$1,398,888
311 Bank Overdraft				
312 Accounts Payable <= 90 Days	\$6,778		\$6,778	\$6,778
313 Accounts Payable >90 Days Past Due				

321	Accrued Wage/Payroll Taxes Payable	\$1,344		\$1,344	\$1,344
322	Accrued Compensated Absences - Current Portion	\$375		\$375	\$375
324	Accrued Contingency Liability				
325	Accrued Interest Payable				
331	Accounts Payable - HUD PHA Programs				
332	Account Payable - PHA Projects				
333	Accounts Payable - Other Government	\$11,294		\$11,294	\$11,294
341	Tenant Security Deposits	\$10,867		\$10,867	\$10,867
342	Unearned Revenue	\$5,220		\$5,220	\$5,220
343	Current Portion of Long-term Debt - Capital Projects/Mortgage Revenue				
344	Current Portion of Long-term Debt - Operating Borrowings				
345	Other Current Liabilities				
346	Accrued Liabilities - Other	\$6,824		\$6,824	\$6,824
347	Inter Program - Due To				
348	Loan Liability - Current				
310	Total Current Liabilities	\$42,702	\$0	\$42,702	\$42,702
351	Long-term Debt, Net of Current - Capital Projects/Mortgage Revenue				
352	Long-term Debt, Net of Current - Operating Borrowings				
353	Non-current Liabilities - Other				
354	Accrued Compensated Absences - Non Current	\$3,378		\$3,378	\$3,378
355	Loan Liability - Non Current				
356	FASB 5 Liabilities				
357	Accrued Pension and OPEB Liabilities	\$28,694		\$28,694	\$28,694
350	Total Non-Current Liabilities	\$32,072	\$0	\$32,072	\$32,072
300	Total Liabilities	\$74,774	\$0	\$74,774	\$74,774
400	Deferred Inflow of Resources	\$6,456		\$6,456	\$6,456
508.4	Net Investment in Capital Assets	\$982,891		\$982,891	\$982,891
511.4	Restricted Net Position				
512.4	Unrestricted Net Position	\$334,767	\$0	\$334,767	\$334,767
513	Total Equity - Net Assets / Position	\$1,317,658	\$0	\$1,317,658	\$1,317,658
600	Total Liabilities, Deferred Inflows of Resources and Equity - Net	\$1,398,888	\$0	\$1,398,888	\$1,398,888

Housing Authority of the City of Huntingburg (IN028)
HUNTINGBURG, IN
Entity Wide Revenue and Expense Summary

Submission Type: Audited/Single Audit

Fiscal Year End: 12/31/2020

	Project Total	14.PHC Public Housing CARES Act Funding	Subtotal	Total
70300 Net Tenant Rental Revenue	\$173,702		\$173,702	\$173,702
70400 Tenant Revenue - Other	\$26,964		\$26,964	\$26,964
70500 Total Tenant Revenue	\$200,666	\$0	\$200,666	\$200,666
70600 HUD PHA Operating Grants	\$104,239	\$11,119	\$115,358	\$115,358
70610 Capital Grants	\$62,245		\$62,245	\$62,245
70710 Management Fee				
70720 Asset Management Fee				
70730 Book Keeping Fee				
70740 Front Line Service Fee				
70750 Other Fees				
70700 Total Fee Revenue				
70800 Other Government Grants				
71100 Investment Income - Unrestricted	\$3,833		\$3,833	\$3,833
71200 Mortgage Interest Income				
71300 Proceeds from Disposition of Assets Held for Sale				
71310 Cost of Sale of Assets				
71400 Fraud Recovery				
71500 Other Revenue	\$137,004		\$137,004	\$137,004
71600 Gain or Loss on Sale of Capital Assets				
72000 Investment Income - Restricted				
70000 Total Revenue	\$507,987	\$11,119	\$519,106	\$519,106
91100 Administrative Salaries	\$49,716		\$49,716	\$49,716
91200 Auditing Fees	\$5,505		\$5,505	\$5,505
91300 Management Fee				
91310 Book-keeping Fee				
91400 Advertising and Marketing				
91500 Employee Benefit contributions - Administrative	\$14,266		\$14,266	\$14,266
91600 Office Expenses	\$4,900		\$4,900	\$4,900
91700 Legal Expense	\$5,772		\$5,772	\$5,772
91800 Travel				
91810 Allocated Overhead				
91900 Other	\$28,499		\$28,499	\$28,499
91000 Total Operating - Administrative	\$108,658	\$0	\$108,658	\$108,658
92000 Asset Management Fee				
92100 Tenant Services - Salaries				
92200 Relocation Costs				
92300 Employee Benefit Contributions - Tenant Services				
92400 Tenant Services - Other	\$1,341	\$11,119	\$12,460	\$12,460
92500 Total Tenant Services	\$1,341	\$11,119	\$12,460	\$12,460
93100 Water	\$12,144		\$12,144	\$12,144
93200 Electricity	\$22,808		\$22,808	\$22,808
93300 Gas	\$8,016		\$8,016	\$8,016
93400 Fuel				
93500 Labor				
93600 Sewer	\$20,729		\$20,729	\$20,729
93700 Employee Benefit Contributions - Utilities				
93800 Other Utilities Expense				
93000 Total Utilities	\$63,697	\$0	\$63,697	\$63,697

94100 Ordinary Maintenance and Operations - Labor	\$14,977		\$14,977	\$14,977
94200 Ordinary Maintenance and Operations - Materials and Other	\$10,934		\$10,934	\$10,934
94300 Ordinary Maintenance and Operations Contracts	\$24,355		\$24,355	\$24,355
94500 Employee Benefit Contributions - Ordinary Maintenance	\$4,298		\$4,298	\$4,298
94000 Total Maintenance	\$54,564	\$0	\$54,564	\$54,564
95100 Protective Services - Labor				
95200 Protective Services - Other Contract Costs				
95300 Protective Services - Other	\$762		\$762	\$762
95500 Employee Benefit Contributions - Protective Services				
95000 Total Protective Services	\$762	\$0	\$762	\$762
96110 Property Insurance				
96120 Liability Insurance				
96130 Workmen's Compensation				
96140 All Other Insurance	\$27,150		\$27,150	\$27,150
96100 Total Insurance Premiums	\$27,150	\$0	\$27,150	\$27,150
96200 Other General Expenses	\$1,391		\$1,391	\$1,391
96210 Compensated Absences				
96300 Payments in Lieu of Taxes	\$11,294		\$11,294	\$11,294
96400 Bad debt - Tenant Rents	\$11,865		\$11,865	\$11,865
96500 Bad debt - Mortgages				
96600 Bad debt - Other				
96800 Severance Expense				
96000 Total Other General Expenses	\$24,550	\$0	\$24,550	\$24,550
96710 Interest of Mortgage (or Bonds) Payable				
96720 Interest on Notes Payable (Short and Long Term)	\$60		\$60	\$60
96730 Amortization of Bond Issue Costs				
96700 Total Interest Expense and Amortization Cost	\$60	\$0	\$60	\$60
96900 Total Operating Expenses	\$280,782	\$11,119	\$291,901	\$291,901
97000 Excess of Operating Revenue over Operating Expenses	\$227,205	\$0	\$227,205	\$227,205
97100 Extraordinary Maintenance				
97200 Casualty Losses - Non-capitalized				
97300 Housing Assistance Payments				
97350 HAP Portability-in				
97400 Depreciation Expense	\$65,772		\$65,772	\$65,772
97500 Fraud Losses				
97600 Capital Outlays - Governmental Funds				
97700 Debt Principal Payment - Governmental Funds				
97800 Dwelling Units Rent Expense				
90000 Total Expenses	\$346,554	\$11,119	\$357,673	\$357,673
10010 Operating Transfer In	\$31,874		\$31,874	\$31,874
10020 Operating transfer Out	-\$31,874		-\$31,874	-\$31,874
10030 Operating Transfers from/to Primary Government				
10040 Operating Transfers from/to Component Unit				
10050 Proceeds from Notes, Loans and Bonds				
10060 Proceeds from Property Sales				
10070 Extraordinary Items, Net Gain/Loss				
10080 Special Items (Net Gain/Loss)				
10091 Inter Project Excess Cash Transfer In				
10092 Inter Project Excess Cash Transfer Out				
10093 Transfers between Program and Project - In				
10094 Transfers between Project and Program - Out				
10100 Total Other financing Sources (Uses)	\$0	\$0	\$0	\$0
10000 Excess (Deficiency) of Total Revenue Over (Under) Total Expenses	\$161,433	\$0	\$161,433	\$161,433

11020 Required Annual Debt Principal Payments	\$0	\$0	\$0	\$0
11030 Beginning Equity	\$1,156,225	\$0	\$1,156,225	\$1,156,225
11040 Prior Period Adjustments, Equity Transfers and Correction of Errors				
11050 Changes in Compensated Absence Balance				
11060 Changes in Contingent Liability Balance				
11070 Changes in Unrecognized Pension Transition Liability				
11080 Changes in Special Term/Severance Benefits Liability				
11090 Changes in Allowance for Doubtful Accounts - Dwelling Rents				
11100 Changes in Allowance for Doubtful Accounts - Other				
11170 Administrative Fee Equity				
11180 Housing Assistance Payments Equity				
11190 Unit Months Available	562		562	562
11210 Number of Unit Months Leased	552		552	552
11270 Excess Cash	\$326,127		\$326,127	\$326,127
11610 Land Purchases	\$0		\$0	\$0
11620 Building Purchases	\$62,245		\$62,245	\$62,245
11630 Furniture & Equipment - Dwelling Purchases	\$0		\$0	\$0
11640 Furniture & Equipment - Administrative Purchases	\$0		\$0	\$0
11650 Leasehold Improvements Purchases	\$0		\$0	\$0
11660 Infrastructure Purchases	\$0		\$0	\$0
13510 CFFP Debt Service Payments	\$0		\$0	\$0
13901 Replacement Housing Factor Funds	\$0		\$0	\$0

HOUSING AUTHORITY OF THE CITY OF HUNTINGBURG
Huntingburg, Indiana

NOTES TO SUPPLEMENTAL FINANCIAL INFORMATION
FOR THE YEAR ENDED DECEMBER 31, 2020

NOTE A - Financial Data Schedule:

As required by HUD, the Authority prepares its financial data schedule in accordance with HUD requirements in a prescribed format. The schedule's format excludes depreciation expense and extraordinary maintenance expense from operating activities, includes investment revenue, HUD capital grants, revenue, gains and losses on the disposal of capital assets and interest expense in operating activities, and reflects tenant revenue and bad debt expense separately, which differs from the presentation of the financial statements.

OTHER REPORTS

Goldie Roberts

Certified Public Accountant

8518 S Kays Chapel Rd.

Fredericksburg, IN 47120

Report On Internal Control Over Financial Reporting and on Compliance and
Other Matters Based On An Audit Of Financial Statements Performed In
Accordance With *Government Auditing Standards*

Independent Auditor's Report

Board of Commissioners
Housing Authority of the
City of Huntingburg
1102 Friendship Village
Huntingburg, Indiana

I have audited, in accordance with the auditing standards generally accepted in the United States of America and the standards applicable to financial audits contained in *Government Auditing Standards* issued by the Comptroller General of the United States, the financial statements of the Housing Authority of the City of Huntingburg, as of and for the year ended December 31, 2020, and the related notes to the financial statements, which collectively comprise the Housing Authority of the City of Huntingburg's basic financial statements and have issued my report thereon dated September 10, 2021.

Internal Control Over Financial Reporting

In planning and performing my audit of the financial statements, I considered the Housing Authority of the City of Huntingburg's internal control over financial reporting (internal control) to determine the audit procedures that are appropriate in the circumstances for the purpose of expressing my opinion on the financial statements, but not for the purpose of expressing an opinion on the effectiveness of the Housing Authority of the City of Huntingburg's internal control. Accordingly, I do not express an opinion on the effectiveness of the Housing Authority of the City of Huntingburg's internal control.

A *deficiency in internal control* exists when the design or operation of a control does not allow management or employees, in the normal course of performing their assigned functions, to prevent, or detect and correct, misstatements on a timely basis. A *material weakness* is a deficiency, or combination of deficiencies, in internal control, such that there is a reasonable possibility that a material misstatement of the entity's financial statements will not be prevented, or detected and corrected on a timely basis. A *significant deficiency* is a deficiency, or a combination of deficiencies, in internal control that is less severe than a material weakness, yet important enough to merit attention by those charged with governance.

My consideration of internal control was for the limited purpose described in the first paragraph of this section and was not designed to identify all deficiencies in internal control that might be material weaknesses or significant deficiencies. Given these limitations, during my audit I did not identify any deficiencies in internal control that I consider to be material weaknesses. However, material weaknesses may exist that have not been identified.

Compliance and Other Matters

As part of obtaining reasonable assurance about whether the Housing Authority of the City of Huntingburg's financial statements are free from material misstatement, I performed tests of its compliance with certain provisions of laws, regulations, contracts and grant agreements, noncompliance with which could have a direct and material effect on the determination of financial statement amounts. However, providing an opinion on compliance with those provisions was not an objective of my audit, and accordingly, I do not express such an opinion. The results of my tests disclosed no instances of noncompliance or other matters that are required to be reported under *Government Auditing Standards*.

Purpose Of This Report

The purpose of this report is solely to describe the scope of my testing of internal control and compliance and the results of that testing, and not to provide an opinion on the effectiveness of the entity's internal control or compliance. This report is an integral part of an audit performed in accordance with *Government Auditing Standards* in considering the entity's internal control and compliance. Accordingly, this communication is not suitable for any other purpose.

Goldie Roberts

Certified Public Accountant

Fredericksburg, Indiana
September 10, 2021

HOUSING AUTHORITY OF THE CITY OF HUNTINGBURG
Huntingburg, Indiana

DECEMBER 31, 2020

SCHEDULE OF FINDINGS AND RESPONSES

STATUS OF PRIOR AUDIT FINDINGS

There were no Prior Year matters reported.

CURRENT AUDIT FINDINGS

No matters were reported.