

# QuadGuard<sup>®</sup> M Wide

## Product Description Assembly Manual

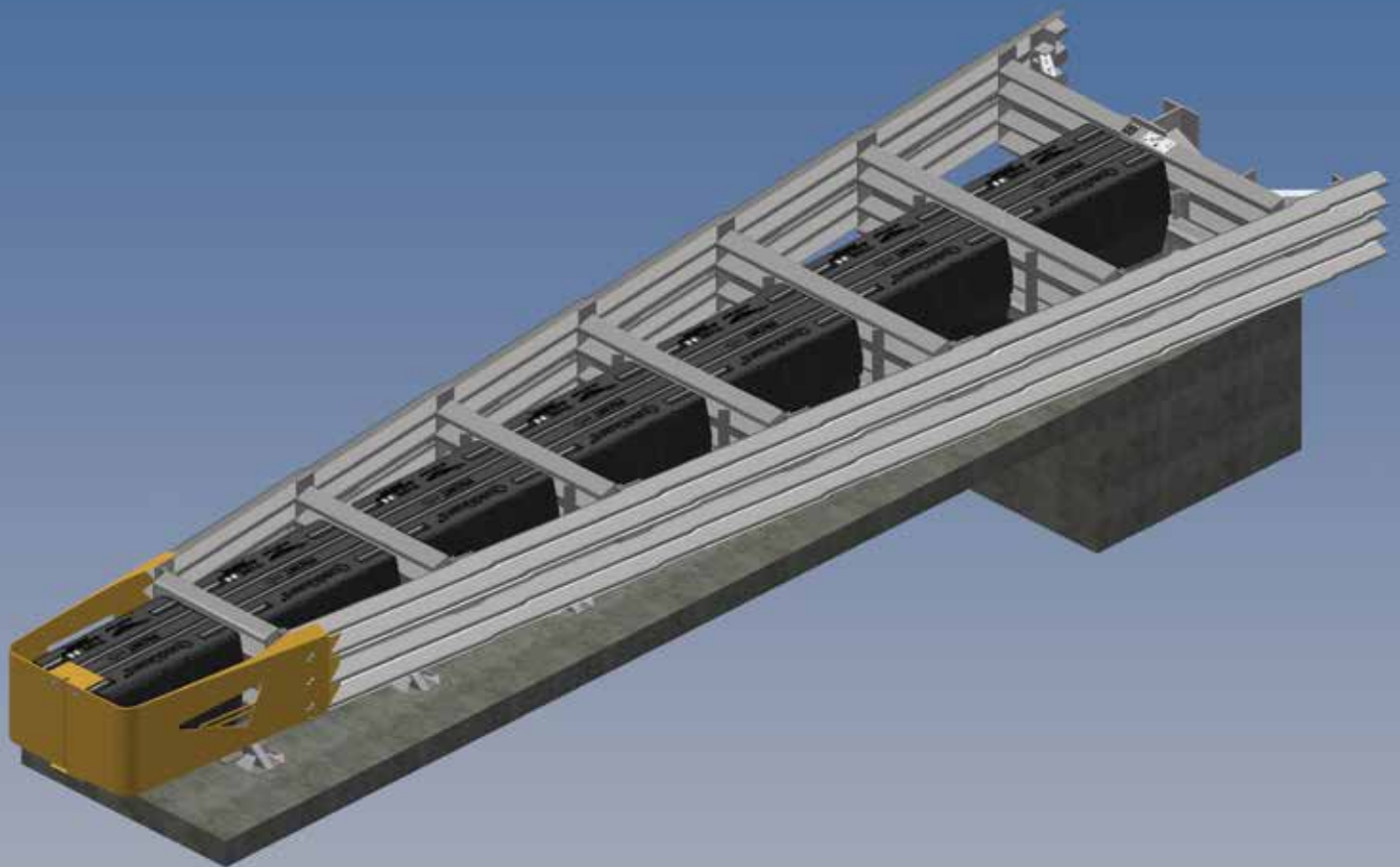

**TRINITY**  
**HIGHWAY**

*Ahead of the Curve<sup>®</sup>*

# QuadGuard® M Wide

The QuadGuard® M Wide has been tested pursuant to American Association of State Highway and Transportation Officials (“AASHTO”) Manual for Assessing Safety Hardware (“MASH”) specifications. The QuadGuard® M Wide has been deemed eligible for federal-aid reimbursement on the National Highway System by the Federal Highway Administration (“FHWA”).

## Product Description Assembly Manual



2525 N. Stemmons Freeway  
Dallas, Texas 75207



**Warning:** The local highway authority, distributors, owners, contractors, lessors, and lessees are **RESPONSIBLE** for the assembly, maintenance, and repair of the QuadGuard® M Wide. Failure to fulfill these **RESPONSIBILITIES** with respect to the assembly, maintenance, and repair of the QuadGuard® M Wide could result in serious injury or death.



**Important:** These instructions are for standard assembly specified by the appropriate highway authority. In the event the specified system assembly, maintenance, or repair would require a deviation from standard assembly parameters, contact a Trinity Highway representative. This system has been deemed eligible by the FHWA for use on the national highway system under strict criteria utilized by that agency.

**This manual must be available to the worker overseeing and/or assembling the product at all times. For additional copies, contact Trinity Highway directly at (888) 323-6374 or visit [TrinityHighway.com](http://TrinityHighway.com).**

The instructions contained in this manual supersede all previous information and manuals. The information, illustrations, and specifications in this manual are based on the latest QuadGuard® M Wide information available to Trinity Highway at the time of printing. We reserve the right to make changes at any time. Please contact Trinity Highway to confirm that you are referring to the most current instructions.

## **Table of Contents**

Customer Service Contacts .....	3
Important Introductory Notes .....	3
Safety Symbols .....	4
Safety Rules for Assembly .....	4
Limitations and Warnings.....	5
System Overview .....	6
Inspect Shipping.....	6
System Components.....	7
Determine Transition Type.....	12
Recommended Tools.....	13
Site Preparation/Foundation .....	15
Foundation/Anchoring.....	16
Trinity Highway Approved Adhesive Anchoring System .....	17
Vertical Anchors.....	17
Anchor Assembly Cautions.....	18
Horizontal Anchors.....	19
System Assembly .....	22
QuadGuard® M Wide Final Inspection Checklist.....	36
Maintenance and Repair.....	37
Inspection Frequency.....	37
Visual Drive-By Inspection .....	37
Walk-Up Inspection Checklist .....	37
Post-Impact Instructions.....	38
Parts Ordering Procedure & Drawings.....	40
QuadGuard® M Wide Tension Strut Backup  QFMTSCVR-U.....	42
Concrete Pad  618686.....	43
Tension Strut Backup  627528 .....	44
Monorail Assembly  625637 .....	45
Diaphragm Assembly  627534 .....	46
Shim Kit  627518.....	49
Fender Panel Assembly  608241 .....	50
Nose Assembly  627522.....	51
31" W-Beam Guardrail Transition  QFMTSCVR-TWLR .....	52
Thrie-Beam Transition  QFMTSCVR-TTLR.....	53
Safety Shape Barrier Transition  QFMTSCVR-T4LRF .....	54
Single Slope Transition  QFMTSCVR-T6LRF .....	55
Vertical Barrier Transition  QFMTSCVR-ESLR .....	56

## Customer Service Contacts

Trinity Highway is committed to the highest level of customer service. Feedback regarding the QuadGuard® M Wide, its assembly procedures, supporting documentation, and performance is always welcome. Additional information can be obtained from the contact information below:

### Trinity Highway

Telephone	(888) 323-6374 (USA) +1 312 467-6750 (International)
Contact Link	<a href="http://TrinityHighway.com/Contact">TrinityHighway.com/Contact</a>

## Important Introductory Notes

Proper assembly of the QuadGuard® M Wide is critical to achieve performance that has been evaluated and deemed eligible by the FHWA per AASHTO MASH criteria. These instructions should be read in their entirety and understood before assembling the QuadGuard® M Wide. These instructions are to be used in conjunction with the assembly of QuadGuard® M Wide and are for standard assemblies only as specified by the applicable highway authority. If you need additional information, or have questions about the QuadGuard® M Wide, please contact the highway authority that has planned and specified this assembly and, if needed, contact Trinity Highway's Customer Service Department. This product must be assembled in the location specified by the appropriate highway authority. If there are deviations, alterations, or departures from the assembly protocol specified in this manual, the device may not perform as tested.



**Important: DO NOT** use any component part that has not been specifically specified herein for the QuadGuard® M Wide during the assembly or repair of this system (pp. 7 – 11 / 40 - 41).

This product has been specified for use by the appropriate highway authority and has been provided to that user who has unique knowledge of how this system is to be assembled. No person should be permitted to assist in the assembly, maintenance, or repair of this system that does not possess the unique knowledge described herein. These instructions are intended for an individual qualified to both read and accurately interpret them as written. These instructions are intended only for an individual experienced and skilled in the assembly of highway products that are specified and selected by the highway authority.

A Manufacturer's Drawing Package will be supplied by Trinity Highway upon request. Each system will be supplied with a specific drawing package unique to that system. Such drawings take precedence over information in this manual and shall be studied thoroughly by a qualified individual who is skilled in interpreting them before the start of any product assembly.

## Safety Symbols

This section describes the safety symbols that appear in this QuadGuard® M Wide manual. Read the manual for complete safety and assembly information.

### Symbol

### Meaning



**Safety Alert Symbol:** Indicates Important, Caution, Warning, or Danger. Failure to read and follow the Important, Caution, Warning, or Danger indicators could result in serious injury or death to workers and/or bystanders.



**Warning:** Read safety instructions thoroughly and follow the assembly directions and suggested safe practices before assembling, maintaining, or repairing the QuadGuard® M Wide. It is the responsibility of the installer to follow the instructions contained in this manual. Failure to comply with these warnings could result in increased risk of serious injury or death in the event of a vehicle impact.



**Important:** Please keep up-to-date instructions for later use and reference by anyone involved in the assembly of the product.

## Safety Rules for Assembly

### **\* Important Safety Instructions \***

This manual must be kept in a location where it is readily available to persons who are skilled and experienced in the assembly, maintenance, or repair of the QuadGuard® M Wide. Additional copies of this manual are available from Trinity Highway by calling (888) 323-6374 or by visiting [TrinityHighway.com/Contact](http://TrinityHighway.com/Contact). Please contact Trinity Highway if you have any questions concerning the information in this manual or about the QuadGuard® M Wide.

It is the responsibility of the installer to use appropriate safety precautions when operating power equipment, mixing chemicals, and when moving heavy equipment or QuadGuard® M Wide components. Safety articles including but not necessarily limited to work gloves, eye protection, safety-toe shoes, and back protection should be used.



**Warning:** It is the responsibility of the installer to use all safety measures incorporating appropriate traffic control devices specified by the highway authority. These measures must be used to protect all personnel while at the assembly, maintenance, or repair site.



**Warning:** Failure to comply with these warnings could result in increased risk of serious injury or death in the event of a vehicle impact with a system that has not been accepted by the FHWA.



**Warning:** Use only Trinity Highway parts on the QuadGuard® M Wide for assembly, maintenance, or repair. The use of component parts not specified herein is **strictly prohibited**. The QuadGuard® M Wide assembled with Trinity Highway Parts has been tested, approved, and accepted for state use by the FHWA. A QuadGuard® M Wide Assembly using parts other than those specified herein has not been tested, approved, or accepted for state use by the FHWA. Failure to follow this warning could result in increased risk of serious injury or death in the event of a vehicle impact.

## **Limitations and Warnings**

Pursuant to MASH “Recommended Procedures for the Safety Performance of Highway Safety Features”, Trinity Highway contracts with FHWA approved testing facilities to perform and evaluate crash tests to prepare a crash test results report. Trinity Highway is then able to submit a Request for Federal Aid Reimbursement of Safety Hardware Devices to the FHWA for review.

The QuadGuard® M Wide has been deemed eligible by FHWA as meeting the requirements and guidelines of MASH. These tests evaluate product performance defined by AASHTO involving lightweight cars (approx. 2420 lb. [1100 kg]) and full size pickup trucks (approx. 5000 lb. [2270 kg]). A product can be certified for multiple Test Levels. The QuadGuard® M Wide is certified to the Test Level(s) as shown below:

### **Test Level 3: 62 mph [100 kph]**

**These AASHTO directed tests are not intended to represent the performance of systems when impacted by every vehicle type or every impact condition existing on the roadway. This system is tested only to the test matrix criteria of MASH as approved by FHWA.**

Trinity Highway expressly disclaims any warranty or liability for injury or damage to persons or property resulting from any impact, collision or harmful contact with products, other vehicles, or nearby hazards or objects by any vehicle, object or person, whether or not the products were assembled in consultation with Trinity Highway or by third parties.

The QuadGuard® M Wide is intended to be assembled, delineated, and maintained within specific state and federal guidelines. It is important for the highway authority specifying the use of a highway product to select the most appropriate product configuration for site specifications. The customer should be careful to properly select, assemble, and maintain the product. Careful evaluation of site layout, traffic speed/type, direction, and visibility are some of the elements that require evaluation by the highway authority in the selection of a highway product. For example, curbs could cause an untested effect on an impacting vehicle.

After an impact occurs, the debris from the impact should be removed from the area immediately and the specified highway product should be evaluated and restored to its original specified condition or replaced as the highway authority determines as soon as possible.



**Warning:** Do not assemble, maintain, or repair the QuadGuard® M Wide until you have read this manual thoroughly and completely understand it. Please contact Trinity Highway if you do not understand these instructions (p. 3).



**Warning:** It is the responsibility of the installer to ensure that all Danger, Warning, Caution, and Important statements within the QuadGuard® M Wide manual are completely followed. Failure to follow this warning could result in serious injury or death in the event of a collision.

## **System Overview**

The QuadGuard® M Wide is a re-directive, non-gating crash cushion for roadside features of 69" [1753 mm] or less in width with use of approved transitions. It consists of energy-absorbing cartridges surrounded by a framework of Quad-Beam Fender Panels.



**Important:** Trinity Highway makes no recommendation whether use or reuse of any part of the system is appropriate or acceptable following an impact. It is the sole responsibility of the project engineer and/or the local highway authority and its engineers to make that determination. It is critical that you inspect this product after assembly is complete to make certain that the instructions provided in this manual have been strictly followed.

The QuadGuard® M Wide utilizes two types of cartridges in a “staged” configuration that are designed and tested to address vehicles as defined by MASH for both lighter cars and heavier, high center-of-gravity vehicles.

### **Impact Performance**

The six (6) Bay QuadGuard® M Wide has successfully passed the requirements stipulated in MASH with both the light car and pickup trucks at speeds of up to 62 mph [100 kph] at redirection angles up to 25 degrees.

During head-on impact testing, within MASH criteria, the QuadGuard® M Wide has been shown to telescope rearward to absorb the energy of impact. When impacted from the side, within the applicable MASH criteria, it has been shown to redirect the vehicle back toward its original travel path and away from the highway feature.



**Warning:** It is the sole responsibility of the project engineer and/or local highway authority and its engineer to ensure that the QuadGuard® M Wide and delineation used meet all federal, state, specifying agency, and local specifications.



**Warning:** It is the sole responsibility of the project engineer and/or local highway authority and its engineer to ensure that the QuadGuard® M Wide meets all appropriate Manual on Uniform Traffic Control Devices (“MUTCD”) and local standards.

### **Inspect Shipping**

Check the received parts against the shipping list supplied with the system before deploying the QuadGuard® M Wide. Make sure all parts have been received (pp. 40 - 41).



**Important:** The Manufacturer’s Drawing Package supplied with the QuadGuard® M Wide must be used with these instructions for proper assembly and should take precedence over these general instructions.







**Warning:** Do NOT modify the QuadGuard® M Wide in any way.



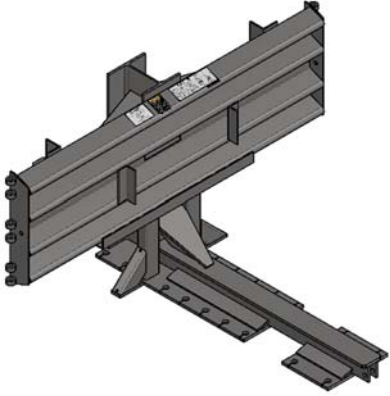
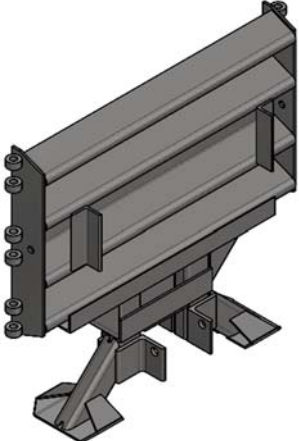
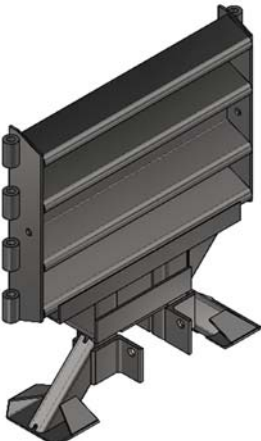
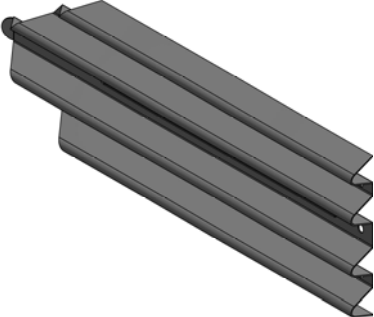

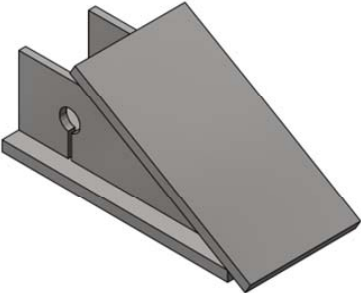
## System Components

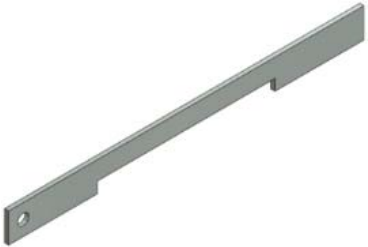
Below is a list of system components that may be used in your particular QuadGuard® M Wide configuration. Verify parts delivered and system details with the BOM (Bill of Materials) and system drawings shipped with your system. Please call Trinity Highway if you have any system questions (p. 3).

**Note:** Components are not shown to scale.

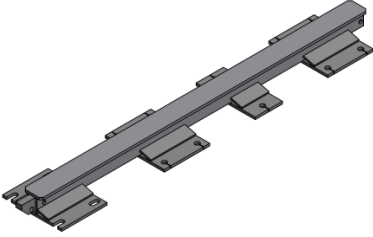
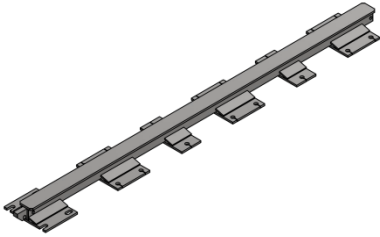
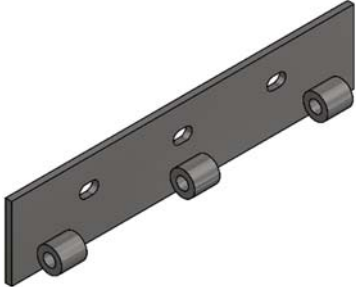
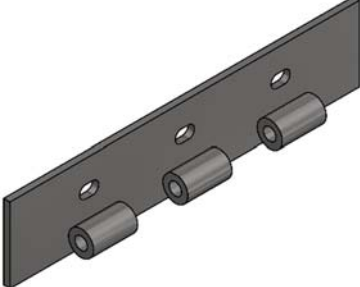
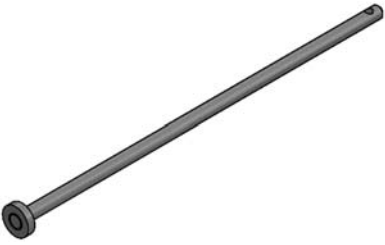
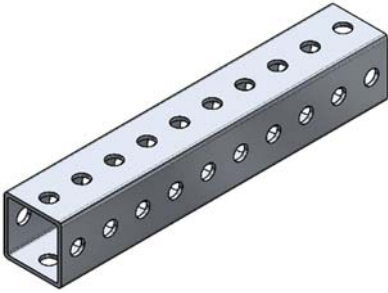
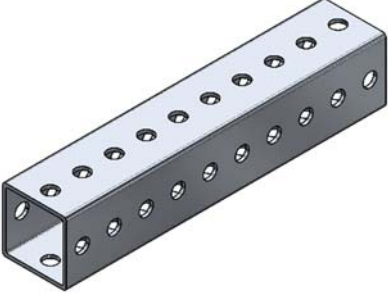

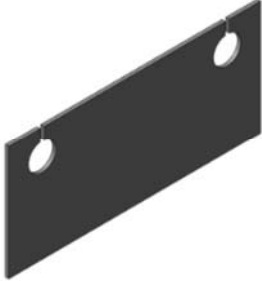
<p>Tension Strut Backup 69"</p> 	<p>Diaphragms 2 - 6</p> 	<p>Diaphragm #1</p> 
<p>627511</p>	<p>Varies</p>	<p>627532</p>
<p>Fender Panel</p> 	<p>Side Panel, Wide</p> 	<p>Bracket, Cartridge Support TS B/U</p> 
<p>611832</p>	<p>611900</p>	<p>605447</p>
<p>End Cap, Monorail</p> 	<p>Bracket, Cartridge Support</p> 	<p>Locking Bar, Cartridge Support</p> 
<p>608136</p>	<p>605446</p>	<p>611266</p>



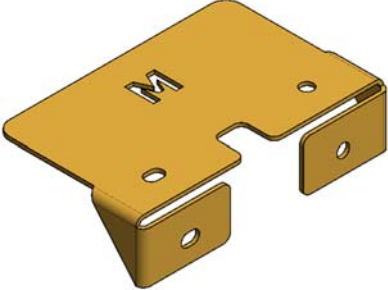
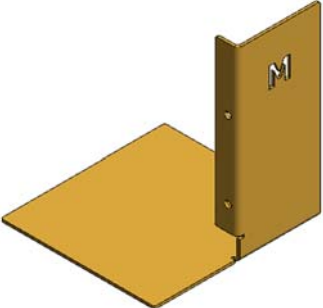
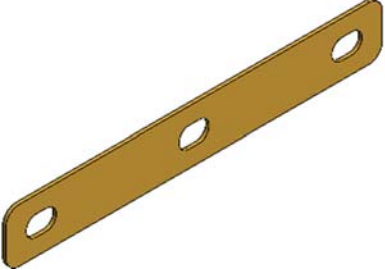

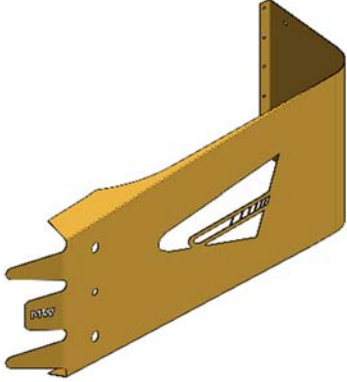
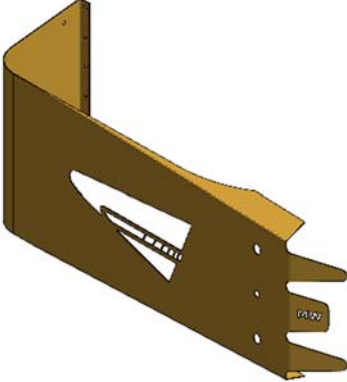
<p>Monorail Guide</p>  <p>611368</p>	<p>Monorail, 2 Bays, QG, G</p>  <p>611375</p>	<p>Monorail, 3 Bays, QG, G</p>  <p>611379</p>
<p>Hinge Plate, Fender Panel</p>  <p>610172</p>	<p>Hinge Plate, Full Length</p>  <p>627524</p>	<p>Hinge Pin, Dia, Full Length</p>  <p>627525</p>
<p>Tel ST 1 3/4X1 3/4X12 GAX10</p>  <p>615756</p>	<p>Tel ST 2X2X12 GAX10</p>  <p>615765</p>	<p>Pipe, 3/4 Schedule 80X2 5/16</p>  <p>626819</p>
<p>Shim, 12GAX3 5/8X8</p>  <p>614062</p>	<p>Bracket, Angle, 2X1, W/Holes</p>  <p>626817</p>	<p>Bracket, Pull-Out</p>  <p>605535</p>

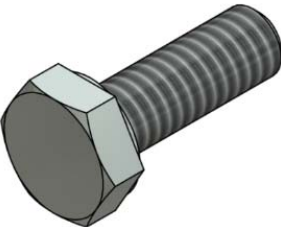

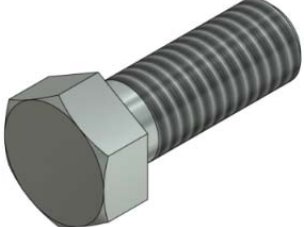
<p>Bracket, Cart, Hold Down</p> 	<p>Bracket, Cart Support, Nose</p> 	<p>Washer, Bar, 10GAX2X14</p> 
626815	626816	626818

<p>Nose, L, QG M Wide</p> 	<p>Nose, R, QG M Wide</p> 
627513	627514

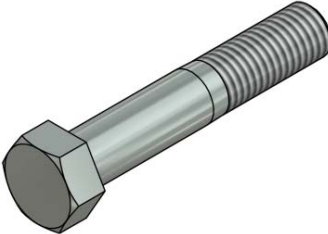

<p>Bolt, Hex, 1/4X3/4, G5</p> 	<p>Bolt, Hex, 1/4X1, G5</p> 	<p>Bolt, Hex, 3/8X1, G5</p> 
113518	113508	113596

<p>Bolt, Hex, 3/8X3 1/2, G5</p> 	<p>Bolt, Hex, 5/8X2, G5</p> 	<p>Bolt, Hex, 5/8X3 1/2, G5</p> 
113612	118570	113660

<p>Bolt, Hex, 5/8X4, G5</p> 	<p>Bolt, Hex, 5/8X5, G8, P, F/T</p> 	<p>Flat Screw 5/8X8 1/2,G8</p> 
113666	119163	116879
<p>Bolt, Hex, 3/4X2, G8</p> 	<p>Rail Bolt, 5/8X2</p> 	<p>Stud, 3/4X7, G5</p> 
113555	003400	117542
<p>Nut, Hex, 1/4</p> 	<p>Nut, Hex, 3/8</p> 	<p>Rail Nut, Hex, 5/8</p> 
115946	115960	003340
<p>Nut, Hex, 5/8</p> 	<p>Nut, Heavy Hex, 3/4</p> 	<p>Washer, Lock 3/8 G</p> 
003354	003704	118092
<p>Washer, Lock, 5/8</p> 	<p>Washer, Lock, 3/4</p> 	<p>Washer, Flat 3/8X1</p> 
118100	118089	118036

Washer, Fender, 3/8X2 	Washer, Flat, 5/8X1 3/4 	Washer, Flat, 3/4X2,Hvy 
118038	003300	118027

Die Spring, 1 1/2 ODX3/4X6 	Mushroom Washer 	Approved Adhesive 
117458	617045	118710

Cartridge Assy, Type I 	Cartridge Assy, Type II 
606027	606029

## Determine Transition Type

**Note:** A proper Transition Panel or Side Panel must be used on each side of the Backup. A Side Panel is not needed when a Transition Panel is used. Several types of transitions are available for use with the QuadGuard M Wide (Figures 1 – 6). The correct Panel(s) to use will depend on the direction of traffic and what type of barrier or road feature the QuadGuard® M Wide is shielding. Contact Customer Service prior to deployment if you have any questions (p. 3).



**Important:** The QuadGuard M Wide is available with transitions to concrete barrier, guardrail, and other roadside features. Contact Customer Service for any transition questions (p. 3).

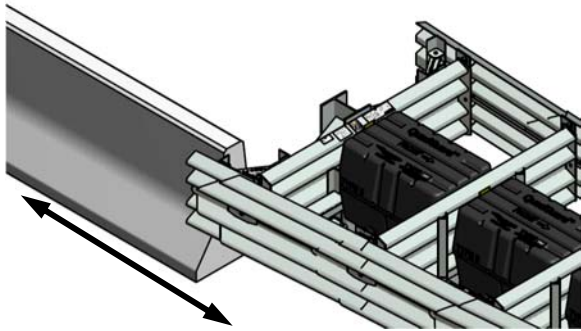

**Figure 1**  
No Transition  
(Unidirectional only)

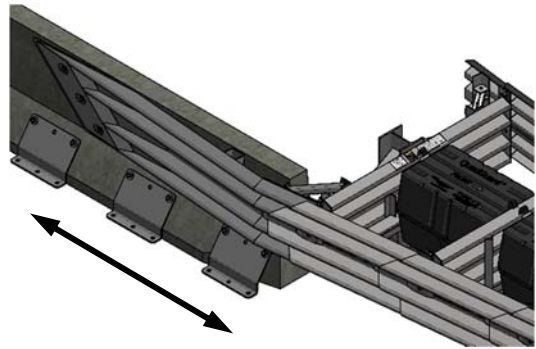

**Figure 2**  
Safety Shape Barrier

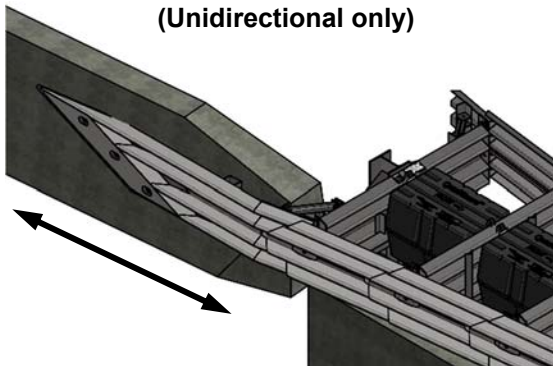

**Figure 3**  
Single Slope Offset

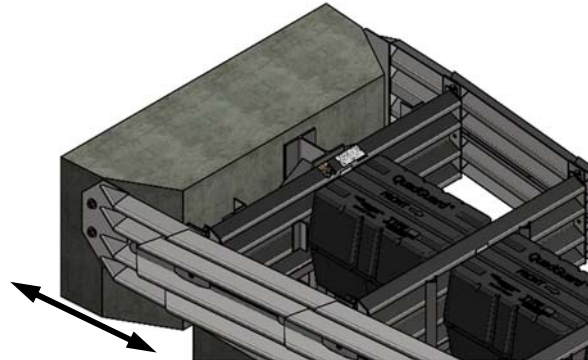

**Figure 4**  
Vertical Barrier

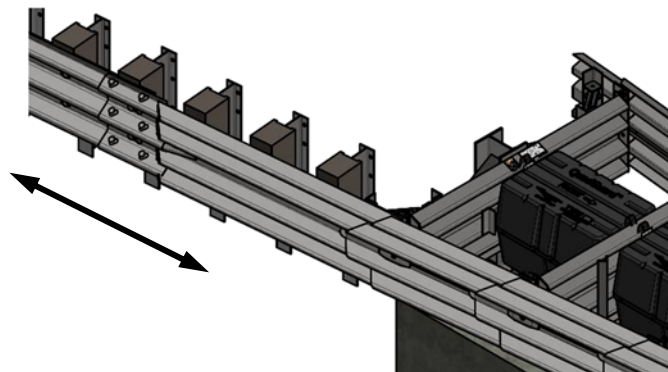

**Figure 5**  
Quad to Thrie-Beam

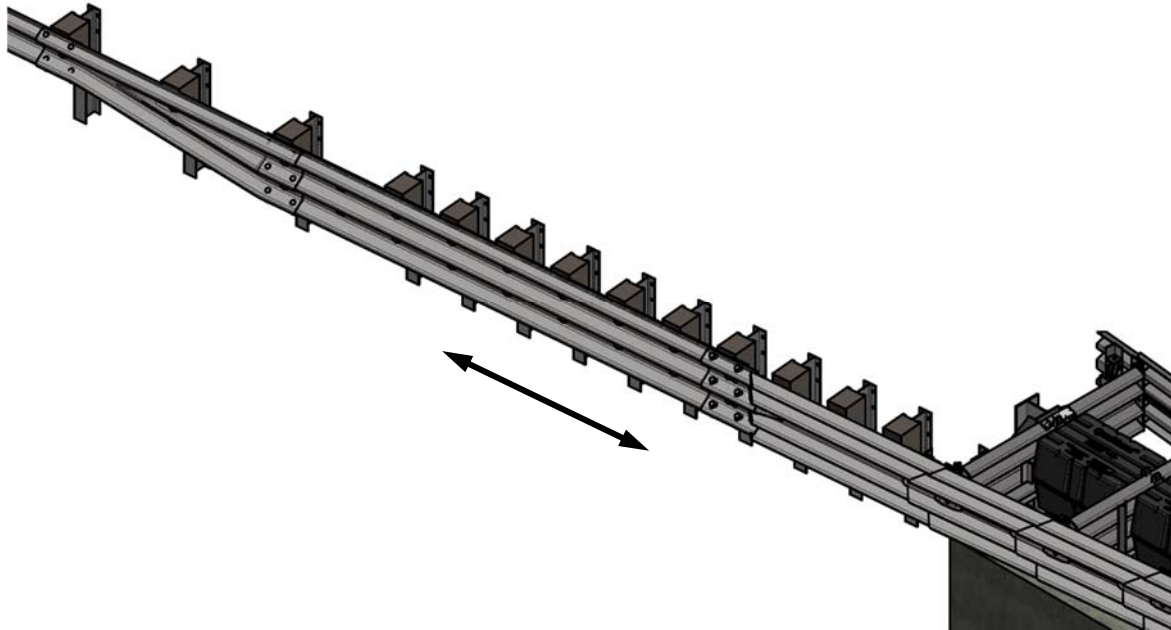

**Figure 6**  
Quad to W-Beam Guardrail

## **Recommended Tools**

### **Documentation**

- Manufacturer's Assembly Manual
- Manufacturer's Drawing Package

### **Personal Protective equipment**

- Eye Protection
- Gloves
- Safety-toe Shoes
- Protective Clothing
- Reflective Vest

### **Cutting equipment**

- Rotary Hammer Drill
- Rebar cutting bit
- Concrete drill bits – 7/8" [22 mm] (**Double-Fluted**)
- Grinder, Hacksaw or Torch (optional)



**Important:** Trinity Highway recommends using **double-fluted** drill bits to achieve optimum tensile strength when applying an approved adhesive anchoring system (p. 17).

## Hammers

- Sledgehammer
- Standard hammer

## Wrenches

- Heavy duty 1/2" drive impact wrench
- 1/2" drive sockets: 7/16", 9/16", 15/16", 1 1/16", 1 1/8", 1 1/4"
- 1/2" drive Deep well sockets: 15/16", 1 1/4"
- 1/2" drive Ratchet and attachments
- 1/2" drive Breaker bar – 24" long
- 1/2" drive Torque wrench: 200 ft-lb
- Combination wrench(s): 7/16", 9/16", 15/16", 1 1/8"
- Hex Key (Allen) wrench: 3/8"



**Important:** Trinity Highway makes no recommendation whether use or reuse of any part of the system is appropriate or acceptable following an impact. It is the sole responsibility of the project engineer and/or the local highway authority and its engineers to make that determination. It is critical that you inspect this product after assembly is complete to make certain that the instructions provided in this manual have been strictly followed.

## Miscellaneous

- Traffic control equipment
- Lifting and moving equipment (A lifting device is preferred although a forklift can be used.) Minimum 5,000 lb. capacity required.
- Air Compressor (100 psi minimum) and Generator (5 kW)
- Long pry bar
- Drift pin 12" [300 mm]
- Center punch
- Tape measure 25' [7.5 m]
- Chalk line
- Concrete marking pencil
- Steel bristled tube brush for cleaning 7/8" drilled boreholes
- Rags, water, and solvent for touch-up

**Note:** The provided list of tools is a general recommendation and should not be considered an extensive list. Depending on specific site conditions and the complexity of the assembly specified by the appropriate highway authority, the required tools may vary. Decisions as to what tools are needed to perform the job are entirely the responsibility of the specifying highway authority and the authority's selected contractor performing the assembly of the system at the authority's specified assembly site.

## Site Preparation/Foundation

A QuadGuard® M Wide, for permanent applications, should be assembled on an existing or freshly placed and cured concrete base (28 MPa [4000 psi] minimum). Location and orientation of the concrete base and attenuator must comply with project plans or as otherwise determined by the local highway authority.

Recommended dimension and reinforcement specifications for new concrete foundations are provided in Trinity Highway concrete foundation drawings, supplied with the system. The system may also be assembled on reinforced or non-reinforced concrete roadway (minimum 8" [200 mm] thick). Deployment cross-slope shall not exceed 8% and should not twist more than 2% over the length of the system; the foundation surface shall have a light broom finish.



**Warning:** It is the responsibility of the installer to ensure proper site grading for the QuadGuard® M Wide placement as dictated by the state or specifying agency pursuant to the AASHTO Roadside Design Guide.



**Caution:** Accurate placement of all steel rebar is critical to avoid interference with the concrete anchor bolts.

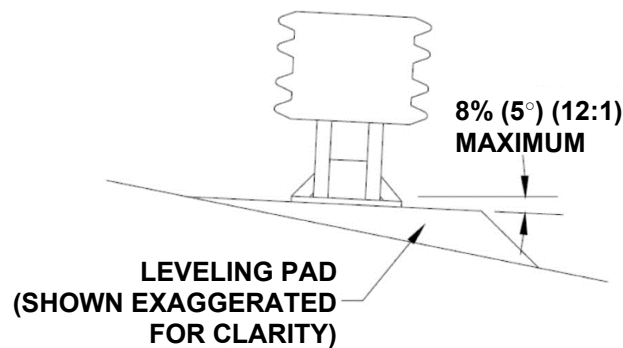

**Figure 7**  
**Cross-Slope**



**Warning:** Location of the Backup in relation to nearby objects will affect the operation of the attenuator. Upon impact, the Fender Panels telescope rearward and extend beyond the rigid Backup as much as 30" [762 mm]. Position the Backup so that the rear ends of the last Fender Panels are a minimum of 30" [762 mm] forward of objects that would otherwise interfere with movement of the rearmost Fender Panels. Failure to comply with this requirement is likely to result in system performance which has not been crash tested pursuant to MASH criteria and may also cause component damage which will necessitate maintenance or replacement of the system.



**Important:** QuadGuard® M Wide cannot be mounted on asphalt.



## Foundation/Anchoring



**Important:** It is the responsibility of the local DOT or appropriate highway authority to ensure that this assembly conforms to the AASHTO Roadside Design Guide.



**Warning:** It is the responsibility of the installer to ensure that your assembly procedure meets all appropriate Occupational Safety and Health Administration (“OSHA”) and local standards.

### Concrete Installations

For concrete installations, the QuadGuard® M Wide should be installed only on an existing or freshly placed and cured concrete base (4000 psi [28 MPa] minimum). Orientation of the concrete base and the attenuator must comply with the project plans or as otherwise determined by the resident project engineer or appropriate highway authority.

Recommended dimension and reinforcement specifications for new concrete pads can be found on the standard drawings.

The QuadGuard® M Wide may be installed on any of the following foundations using the specified anchorage:

#### Foundation A: Reinforced Concrete Pad or Roadway

Foundation: 6” [152 mm] (reinforced) **with Anchor Block** minimum thickness P.C.C.

Anchorage: Approved adhesive with 7” [178 mm] studs 5 1/2” [140 mm] embedment

#### Foundation B: Reinforced or Non-Reinforced Concrete Pad or Roadway

Foundation: 8” [203 mm] minimum thickness P.C.C.



**Important:** To prevent sliding during impact, the pad must be placed against or tied to an existing structure. Additional below grade supports may also be necessary as the project engineer directs.

Anchorage: Approved adhesive with 7” [178 mm] studs 5 1/2” [140 mm] embedment

# **Trinity Highway Approved Adhesive Anchoring System**

A Trinity Highway approved adhesive anchoring system is required to securely anchor crash cushions. Each approved adhesive kit contains adhesive, studs, nuts and washers. Both vertical and horizontal assemblies are possible using an approved adhesive anchoring system.

## **Vertical Anchors**

**Note:** Read all Trinity Highway approved adhesive instructions before starting.

### **1) Prepare the Concrete Foundation**



**Warning:** Do not allow anchoring adhesive to contact skin or eyes. See material safety data sheet supplied with adhesive kit for first-aid procedures. Use only in well-ventilated area. Do not use near open flame.



**Warning:** It is the responsibility of the installer to maintain a safe work area including the use of standard work zone safety equipment & PPE: gloves, safety-toe shoes, and eye / ear protection.

The anchor bolts (studs) that anchor the QuadGuard® M Wide Backup and/or Monorail sections to the concrete foundation must be those shipped in the kit or of high strength steel (120,000 psi [830 MPa] minimum tensile strength or equal). These studs must be set in minimum 4000 psi [28 MPa] concrete. Allow the concrete to cure a minimum of seven days before applying anchoring adhesive.

### **2) Drill Boreholes**



**Caution:** It is the responsibility of the installer to consult OSHA silica respiratory standard 29 CFR 1910.134 for debris removal from borehole(s) and use Trinity Highway approved adhesive to achieve optimum tensile strength. Do not use diamond drill bits for drilling boreholes.

Use the Monorail(s) and Tension Strut Backup as drilling templates. Use a rotary hammer drill to drill the boreholes 7/8" [22 mm] diameter to the recommended depth. See the approved adhesive instructions provided with adhesive kit. Check ensure each borehole is drilled to the proper depth and aligned with the part to be anchored per Anchoring Information table.

<b>Anchoring Information</b>					
<b>Stud Size:</b>	<b>Orientation</b>	<b>Bit Size</b>	<b>Minimum Depth</b>	<b>Torque</b>	<b>Medium</b>
3/4"X7"	Vertical	7/8" [22 mm]	5 3/4" [145 mm]	Adhesive Manufacturer Spec	Concrete

### **3) Clean the Boreholes**

Blow the concrete dust from the borehole using oil-free compressed air. Thoroughly brush it with a 7/8" diameter steel bristle tube brush and then blow it out again. If the borehole is wet, completely flush it with water while brushing and then blow it clean to remove all water using oil-free compressed air.

**Note:** Use of the Trinity Highway approved vacuum drilling equipment is authorized to replace the blowing and brushing requirement of Step 3.

#### 4) Apply Approved Adhesive

Fill the borehole 100% full.



**Caution:** Fill borehole 100% full so it is even with the pavement surface per manufacturer's instructions.

#### 5) Add the Washers and Nuts

Place a flat washer onto the stud then thread a nut on until the end of the stud is flush with the nut (Figure 8).

#### 6) Insert Studs in Boreholes and Wait for Adhesive to Cure

Push the stud down through the part to be anchored and into the borehole.



**Caution:** Do not disturb or load the stud until the approved adhesive material has fully cured (reference instructions supplied with the approved adhesive kit).

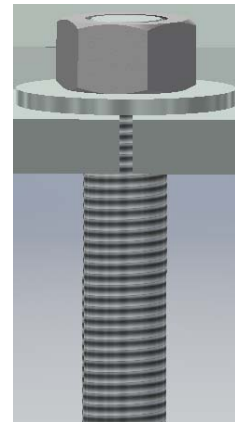

**Figure 8**  
**Vertical Application**  
**(Before Applied Torque)**

#### 7) Torque the Nuts

Once the adhesive has fully cured, torque the nut to the adhesive manufacturer's recommended values.

### Anchor Assembly Cautions

#### 1) Steel rebar

If steel rebar is encountered while drilling an anchor bolt borehole, apply one of the following solutions:

A) Use a rebar drill bit for the **rebar only** and then switch back to the concrete bit to finish drilling into the underlying concrete until the proper borehole depth is reached.



**Caution:** Do not drill through rebar without first obtaining permission to do so from the project engineer.

B) Drill a new borehole down at an angle past the rebar to the proper depth. Anchor the stud by completely filling both boreholes with an approved adhesive.

## Horizontal Anchors

The horizontal approved adhesive kit is the same as the vertical kit.



**Caution:** Fill borehole 100% full so it is even with the vertical concrete surface per manufacturer's instructions.

### 1) Follow the instructions supplied with your approved adhesive kit

Apply approved adhesive to each anchor per instructions.

### 2) Add the Washers and Nuts

Put washer and nut on stud so the **nut is flush with end of stud**.

### 3) Insert each Stud with Washer and Nut into Borehole

Push stud with washer and nut into borehole.



**Important:** The stud should be flush with the top of the nut in both **vertical** and **horizontal** applications prior to tightening (Figure 9).

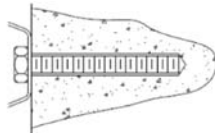

**CORRECT**

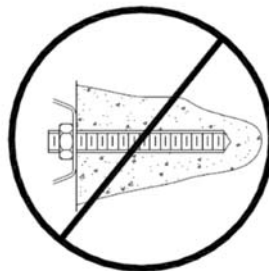

**INCORRECT**

**Figure 9**  
**Horizontal Application**  
**(Before Applied Torque)**



**Caution:** Do not disturb or load the stud until the approved adhesive material has hardened (reference approved adhesive kit instructions for hardening times).

### 4) Torque the nuts

Once the adhesive has fully cured, torque nut(s) to the approved adhesive manufacturing specification.

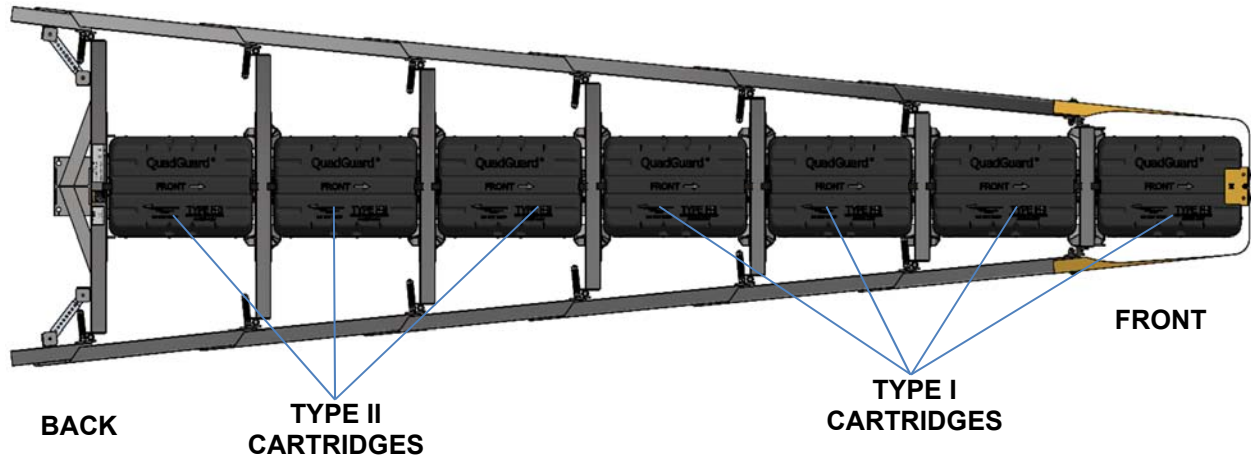

Figure 10 Plan View

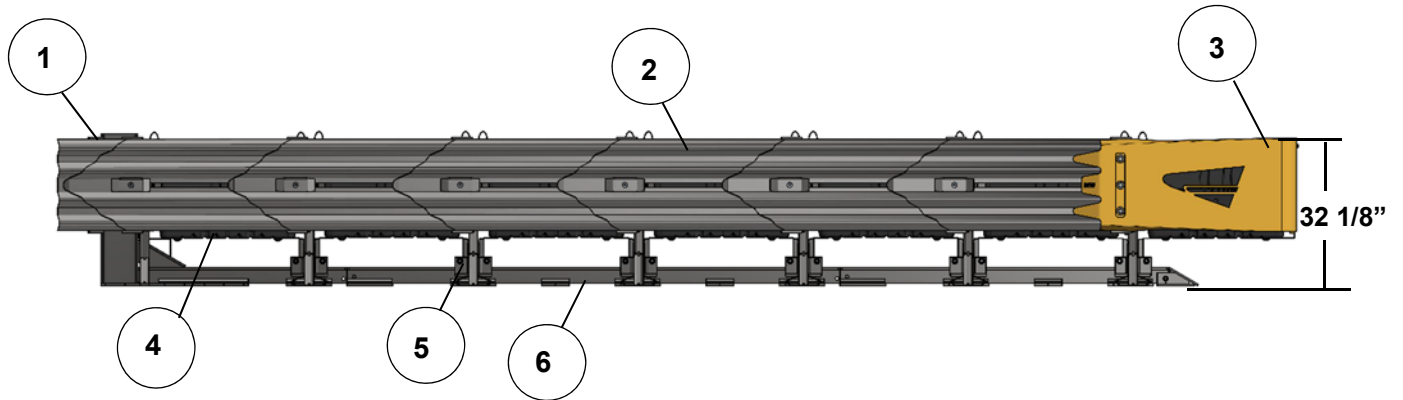

Figure 11 Elevation View  
6 Bay TL-3

**KEY**

- 1) Backup
- 2) Quad-Beam Fender Panel
- 3) Nose
- 4) Cartridge
- 5) Diaphragm
- 6) Monorail

## How to Determine Left/Right

To determine left from right when ordering parts, stand in front of the system facing the roadside obstacle. Your left is the system's left and your right is the system's right.

## Counting the Number of Bays

One Bay consists of one Cartridge, one Diaphragm, and two Fender Panels. The Nose section is not considered a Bay, though there is a Cartridge in the Nose of each system.

**Note:** There will always be one more Cartridge in the system than the number of Bays in the system. To determine number of Bays, count Fender Panels on one side (Figure 12).

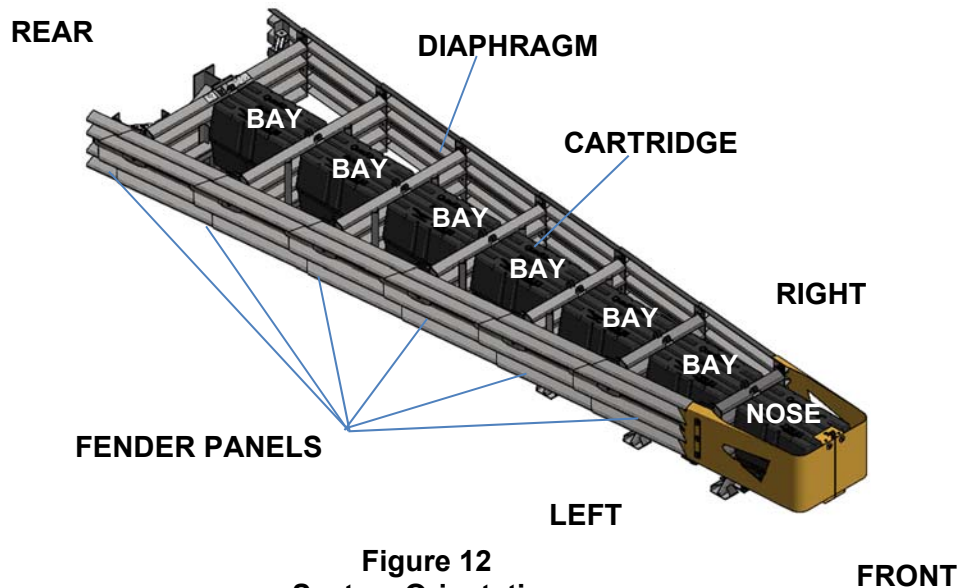

Figure 12  
System Orientation

## Measuring the Width

The nominal width of a **Wide (flared)** system is the width at the location shown (Figure 13). The outside width of the system is approximately 6" [152 mm] wider than the nominal width.

**Note:** The outside width of the system is not the same as the width of the Backup.

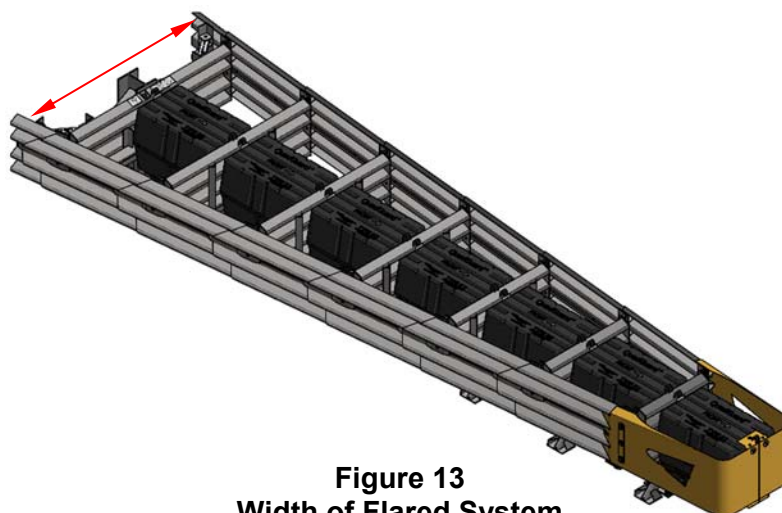

Figure 13  
Width of Flared System

## System Assembly



**Warning:** It is the responsibility of the installer to ensure the assembly procedure meets all appropriate OSHA and local standards.

### 1) Mark System Location

Locate the centerline of the system by measuring the proper offset from the fixed object. Refer to the Drawing Package supplied with the system. Place chalk line to mark the centerline of the system. Mark a construction line parallel to the center line and offset 6.5" [165 mm] to one side as shown in Figure 14. The edge of the Monorail will be positioned on this line.

**Note:** The concrete foundation must comply with the Manufacturer's Drawing Package supplied with the system.



**Warning:** Location of system with respect to the roadside obstacle is critical and dependent on the type of Transition Panel used. Please refer to the Drawing Package supplied with the system for details.

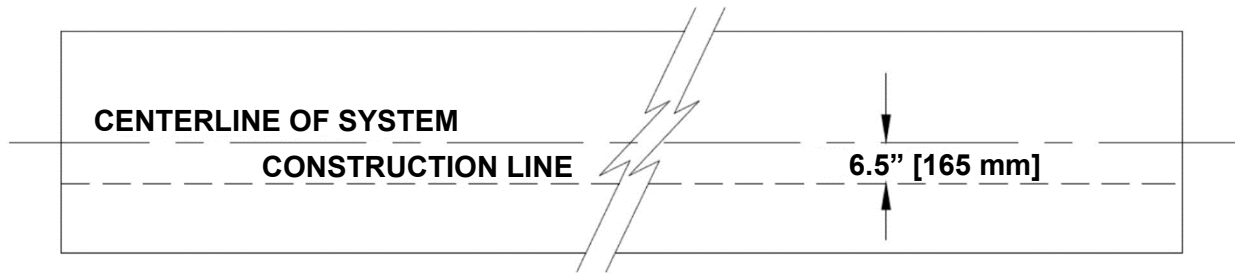

**Figure 14**  
(Top view of concrete foundation)

## 2) Anchor the Tension Strut Backup (Figure 15)

Place Tension Strut Backup and Monorail on foundation with side of Backup and Monorail on the construction line and rear edge of backup mounting pad 4" forward of foundation edge (p. 24). **Verify that any applicable Transition Panels fit properly before anchoring Backup.** Drill 7/8" [22 mm] diameter by 5 3/4" [145 mm] anchor boreholes in foundation using the Backup as template. Anchor the Backup to the concrete foundation using an approved adhesive supplied with the QuadGuard® M Wide.

**Note:** Verify that any applicable Transition Panels fit properly before anchoring Backup.



**Caution:** Every hole in the Backup and Monorail must be anchored by a stud using an approved adhesive.

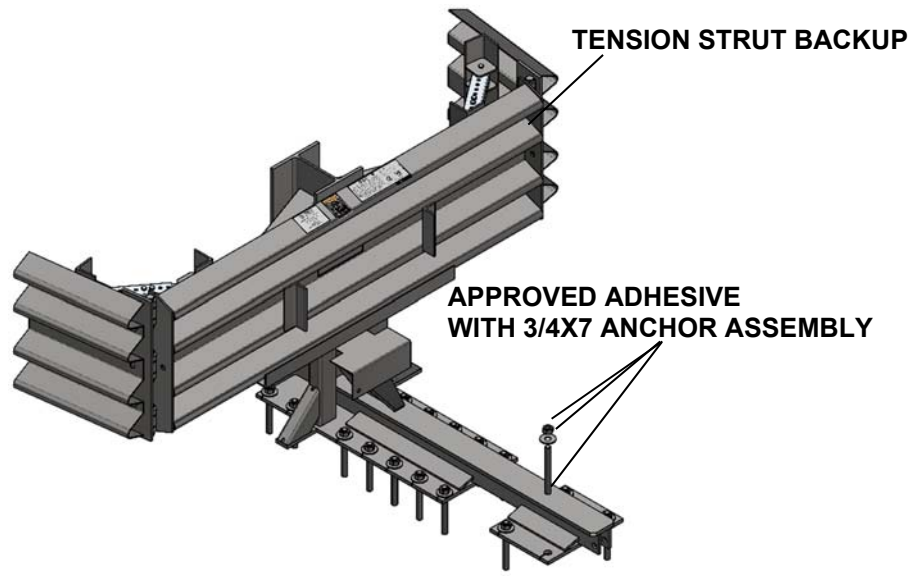

**Figure 15**  
**Anchoring Tension Strut Backup to Foundation**

## 3) Anchor the Monorail

### Monorail Placement for Tension Strut Backup (Figure 16)

Place Monorail on foundation with side of Monorail on construction line. Orient the Monorail so the Monorail tongue faces the Backup and inserts into the backup monorail.



**Warning:** Improper alignment at the Monorail splice joints may prevent proper system collapse during an impact (p. 24, Detail A).

It is important to align each segment of Monorail from the back to the front of the system within ( $\pm 1/4$ " [6 mm]) along the length. Anchor each Monorail section using the Trinity Highway approved adhesive kits provided.



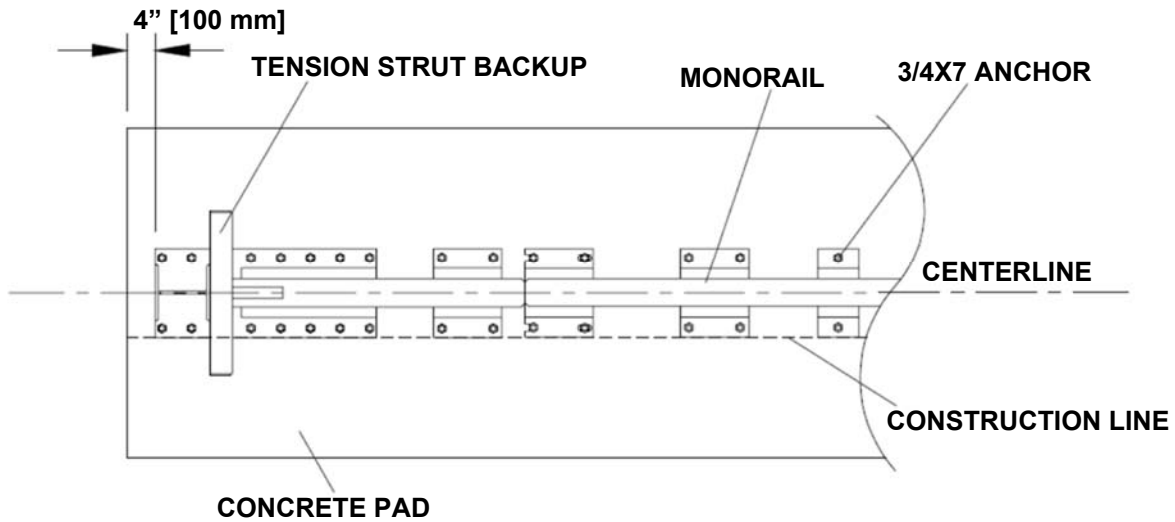

**Figure 16**  
**Backup and Monorail Location for Tension Strut Backup**

Drill 7/8" [22 mm] diameter by 5 3/4" [145 mm] boreholes using the Monorail as a template. Do not drill through foundation.

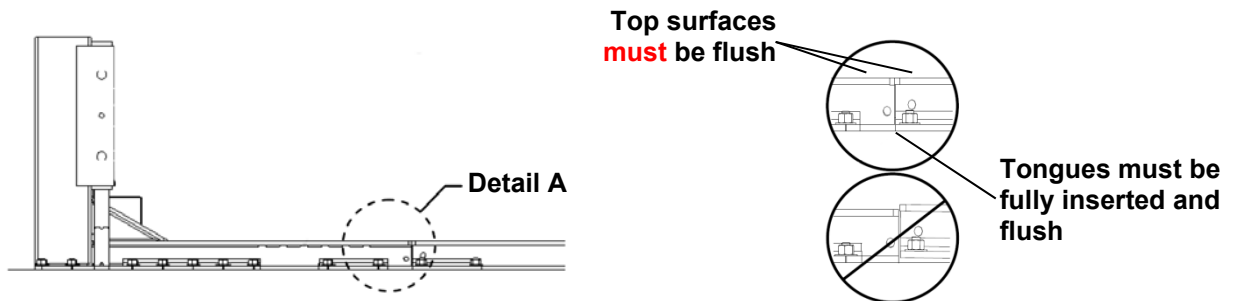

**Figure 17**  
**Rail Height and Alignment**

**Detail A**

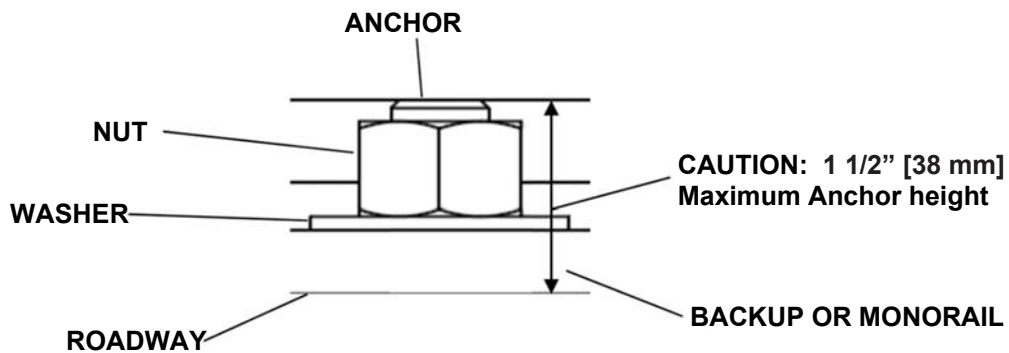

**Figure 18**  
**Final Anchor Height**  
**(After Applied Torque)**

#### 4) Attach Side Panels and/or Transition Panels to Backup Assembly

- A. Attach Hinge Plates to Backup (three (3) places on each side of Backup) using a 5/8" rail bolt, lock washer, and hex nut.
- B. Attach Transition Panel or Side Panel to Hinge Plate using a 5/8" rail bolt and rail nut (two places - top and bottom holes only). See Backup Assembly drawing(s) below.
- C. Attach diagonal brace to Side Panel or transition and Backup using 3/8" a hex bolt, lock washer, and hex nut (two (2) places per brace and four (4) places per side).
- D. Secure each diagonal brace set in two (2) places with a 3/8" hex bolt, lock washer, and hex nut (Figure 19).

**Note:** A Side Panel is unnecessary when a Transition Panel is used.

#### **Assembly Tip:**

Use a drift pin to align the center hole of the Side Panel with the center hole of the Backup before inserting the Rail Bolts.

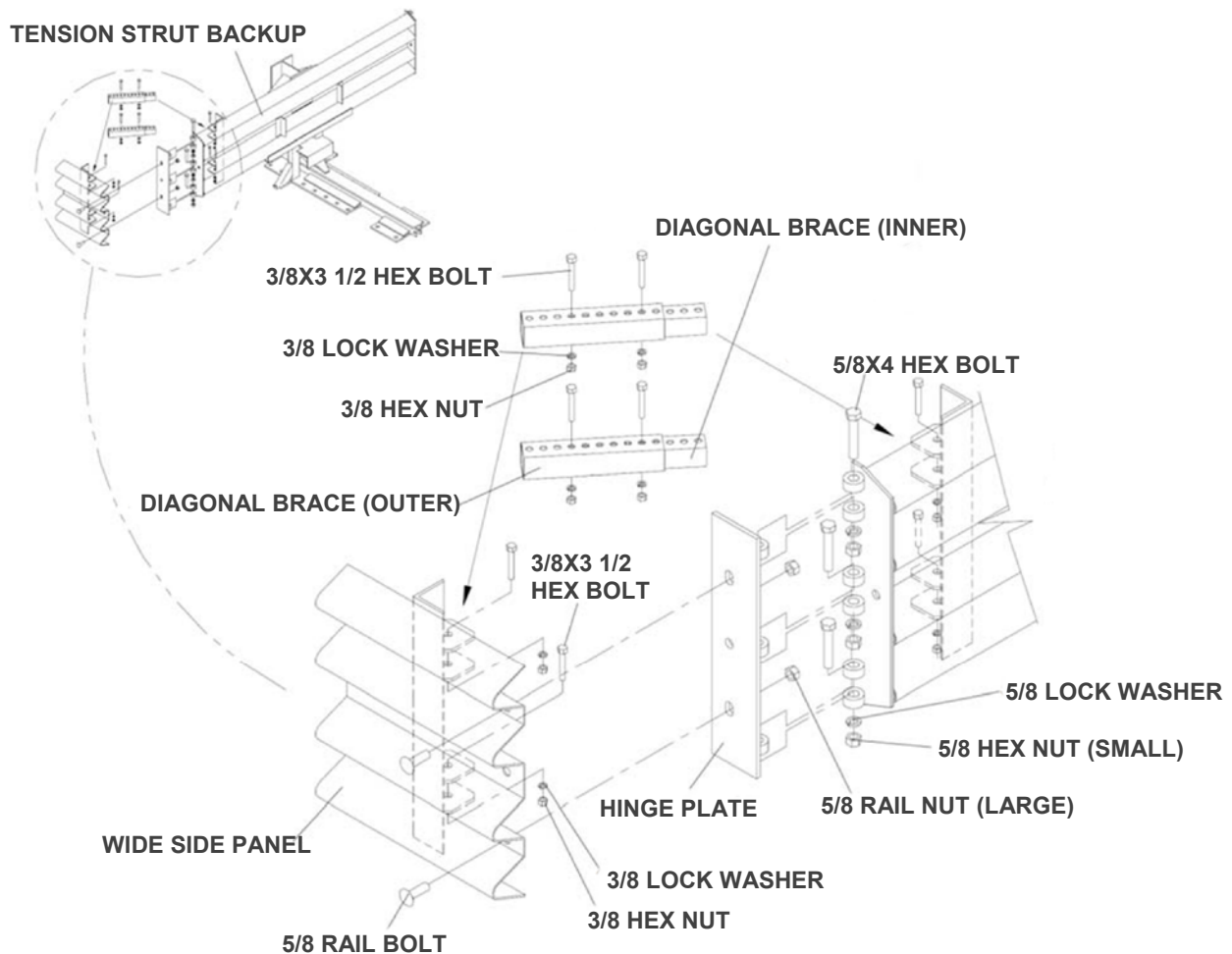

**Figure 19**  
**Side Panel/Transition Panel Attachment**

## 5) Attach Monorail Guides

Attach Monorail guides to Diaphragm as follows:

Insert 3/4X2" G8 hex bolt through Monorail guide and Diaphragm with a shim placed between them and oriented as shown in Figure 20. Secure with 3/4" lock washer and 3/4" hex nut (typical 4 places). See the Diaphragm Assembly drawing supplied with the system.

Repeat process for each Diaphragm.

## 6) Attach Diaphragms

Orient the widest Diaphragm so that the front face of the Diaphragm shape faces toward the Nose of the system as shown in Figure 21. The widest Diaphragm must be attached closest to the Backup with each subsequent Diaphragm being progressively narrower.



**Important:** Slide the widest Diaphragm all the way to the Backup to ensure the system is able to collapse properly during impact. Once verified, slide the Diaphragm forward to 36" [914 mm] in front of the Backup.

Orient and slide all other Diaphragms onto Monorail and position each approximately as shown in Figure 22.

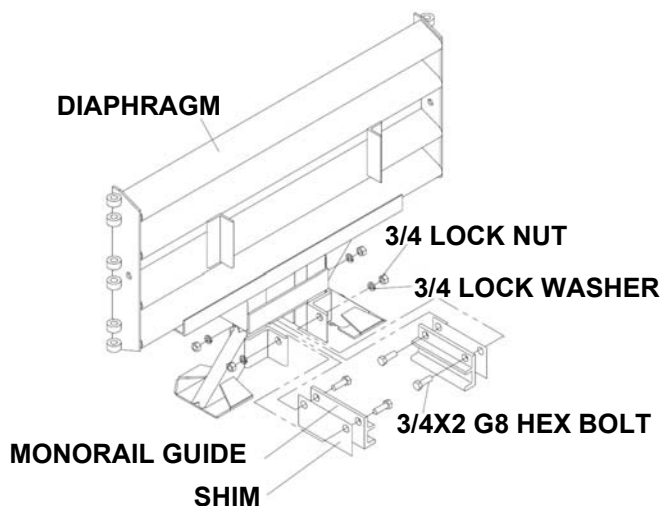

Figure 20  
Monorail Guide Attachment

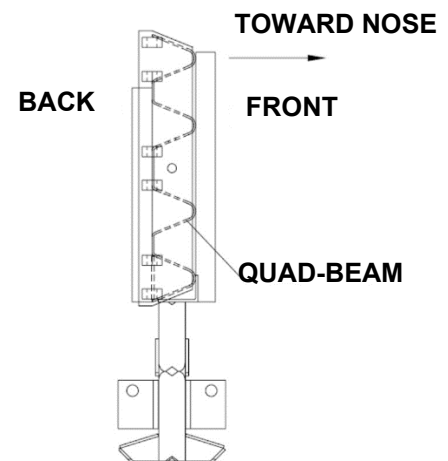

Figure 21  
Diaphragm Orientation

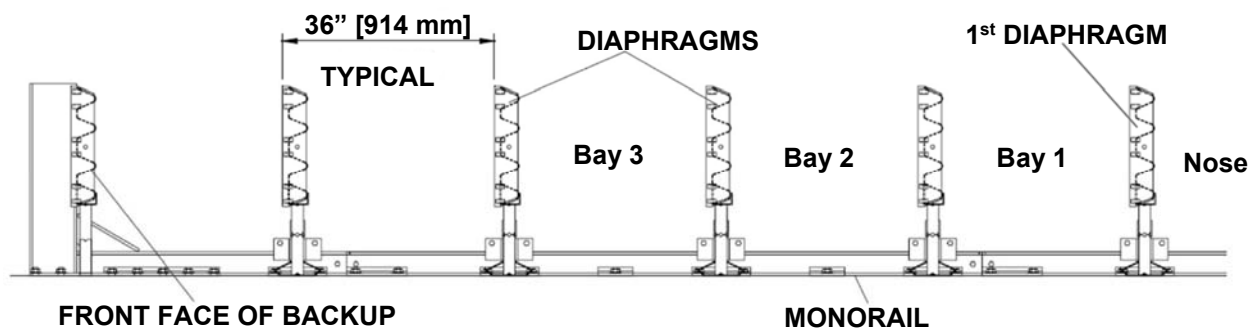

Figure 22  
Diaphragm Spacing

## 7) Attach Hinge Plates to Diaphragm

Attach Hinge Plates to each Diaphragm so the hinge pivot is toward the front of the system. Insert 5/8"X4" hex bolts through all hinges. Secure each bolt with 5/8" lock washer and hex nut (Figure 23). (Typical three places per side on Diaphragms 2-6) Insert Full Length Pin and secure with 1/4X1" bolt and hex nut on 1<sup>st</sup> Diaphragm (Figure 24). See pages 46 and 47 for additional information.

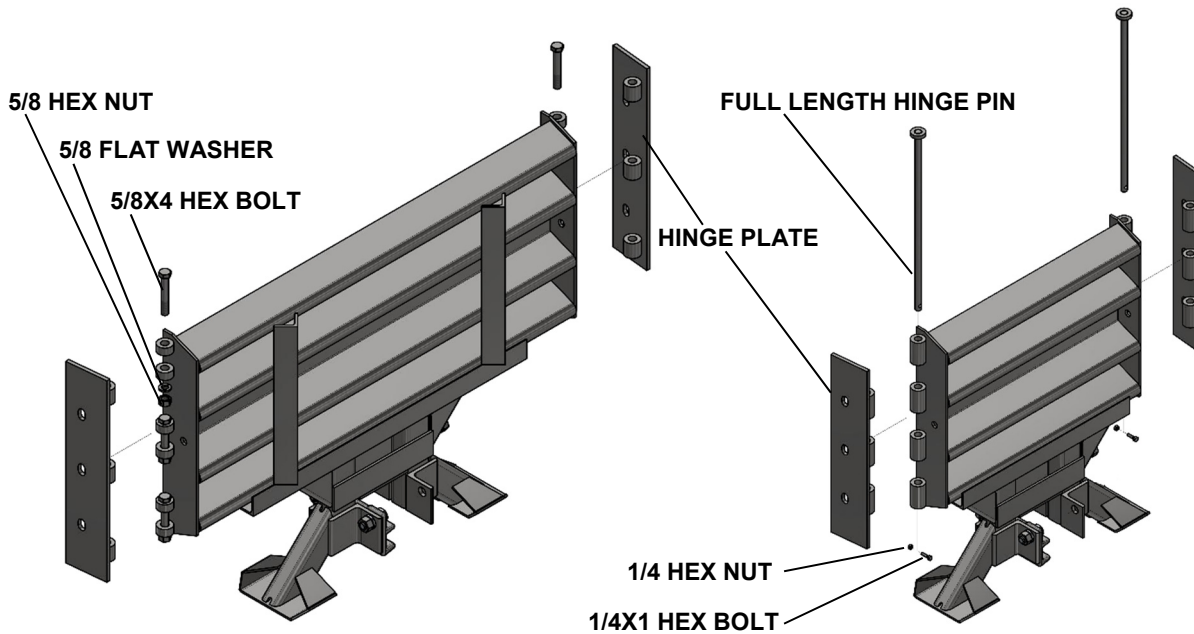

Figure 23 - Hinge Plate Diaphragms 2-6

Figure 24 - Hinge Plate 1<sup>st</sup> Diaphragm

## 8) Attach Fender Panels



**Important:** Do not mix the 5/8" rail nuts (large) with the 5/8" hex nuts (small) (Figure 25).

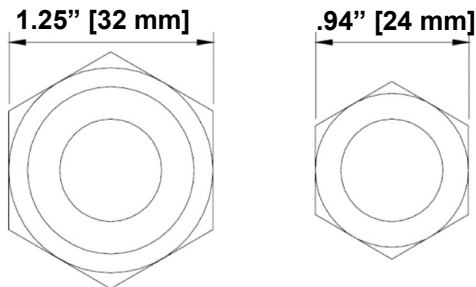

5/8 RAIL NUT (LARGE)    5/8 HEX NUT (SMALL)

Figure 25  
Rail Nuts are Oversize

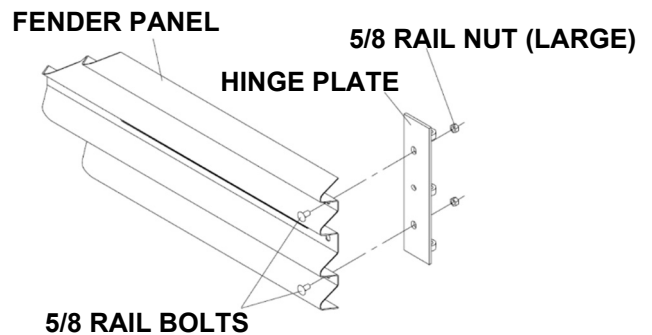

Figure 26 - Hinge Plate to Panel



**Important:** For proper impact performance, Wide systems must use Hinge Plates.

**Note:** Starting at the Backup, attach left and right Fender Panels shown below in Step(s) 4 & 5 with each tapered end pointing toward the rear of the system.

**Step 1**

Place the Fender Panel so that the center of the slot of the backup Hinge Plate is lined up with the approximate center of the slot in the Fender Panel.

Attach Mushroom Washer Assembly as shown in Figure 27, Detail A, and B. Do not tighten fasteners at this time. This first step helps balance the Fender Panel.

**Step 2**

Slide the Fender Panel forward until the holes in the Fender Panel line up with the holes in the forward Diaphragm Hinge Plate.

**Step 3**

Use a drift pin to align the center hole of the Fender Panel with the center hole of the Diaphragm Hinge Plate.

**Step 4**

Attach the front of the Fender Panels to the next Diaphragm Hinge Plate using two (2) rail bolts and large hex nuts per side. Use only the top and bottom holes and leave the center hole open until the next Fender Panel is attached.

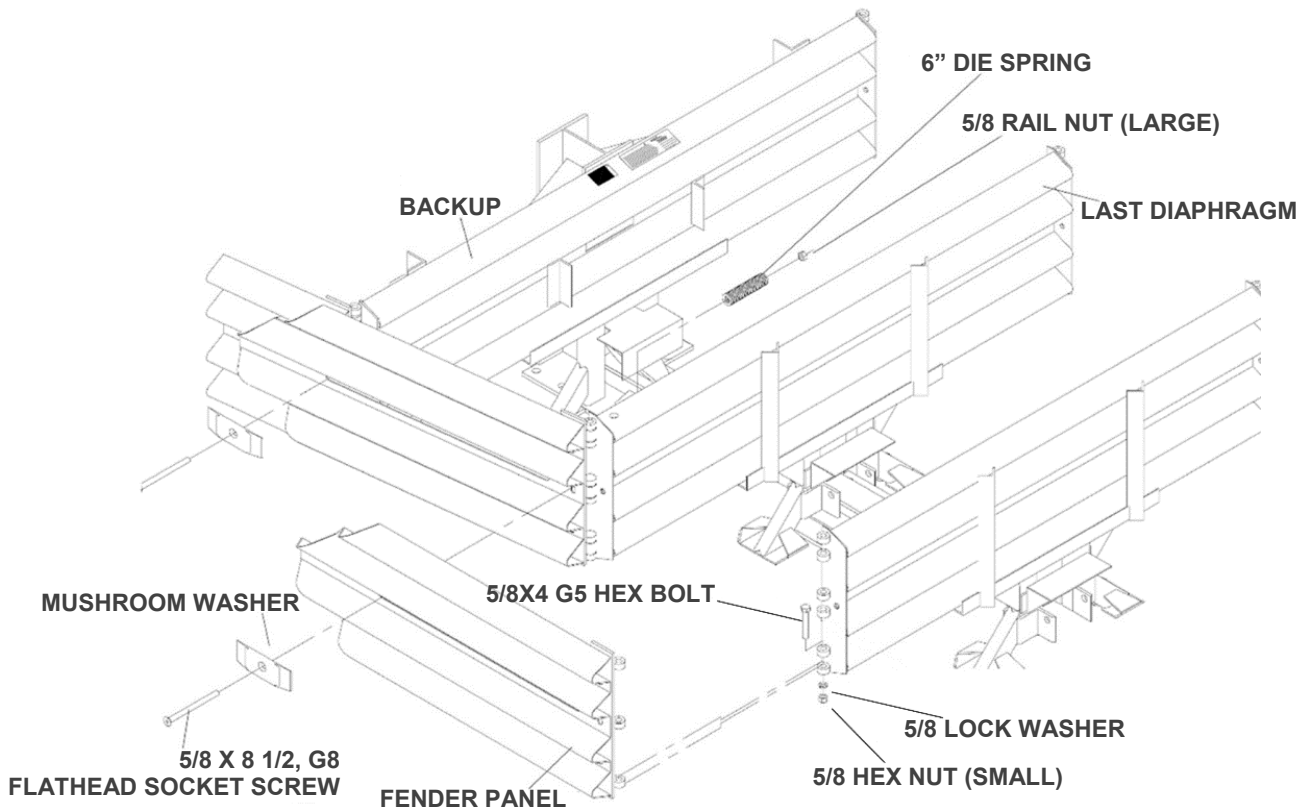

**Figure 27**  
**Wide Fender Panel Assembly**

### Step 5

The Mushroom Washer must lay flat against the Fender Panel with its standoff completely through the Fender Panel slot (Detail B).

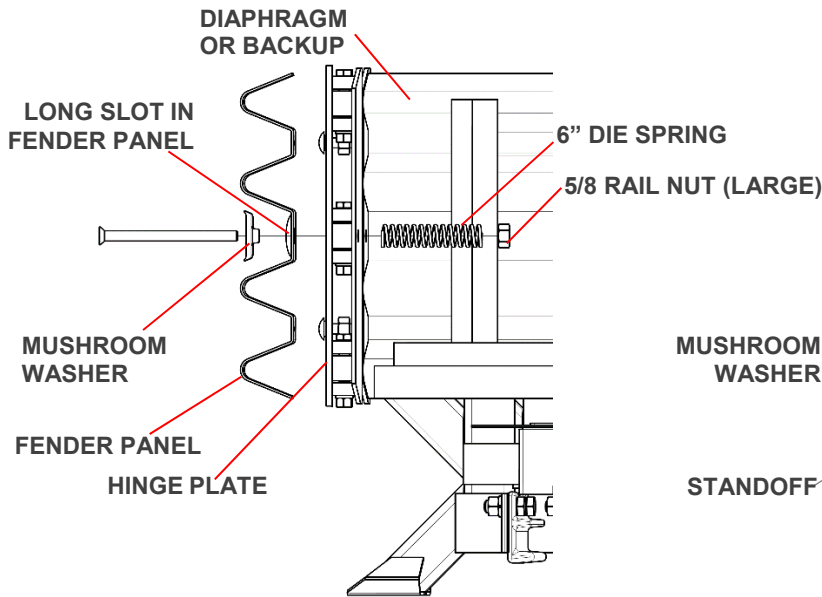

**Detail A**  
**Mushroom Washer Attachment**

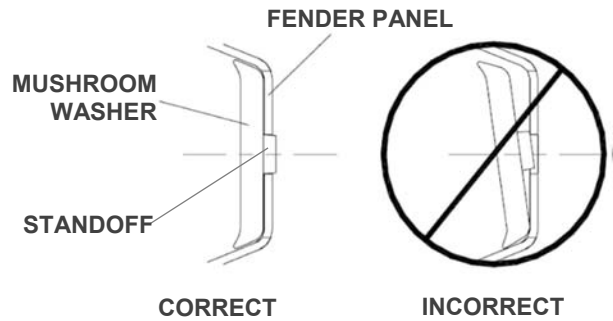

**Detail B**  
**Mushroom Washer Orientation**



**Important:** Starting from the Backup, attach and tighten each Bay section one at a time.

### Step 6

Check Diaphragm spacing to ensure 36" [914 mm] between rear faces of consecutive Diaphragms as shown in Fender Panel assembly drawing (Figure 28).

### Step 7

Once proper spacing has been achieved, tighten the Mushroom Washer Assembly (small hex) nut until it reaches the end of the screw threads.

Assemble the remaining Diaphragms and Fender Panels following the same procedure.

Tighten rail nuts (large hex) at the front of the Fender Panels. Ensure the rail bolt shoulder is seated within the Fender Panel slot.

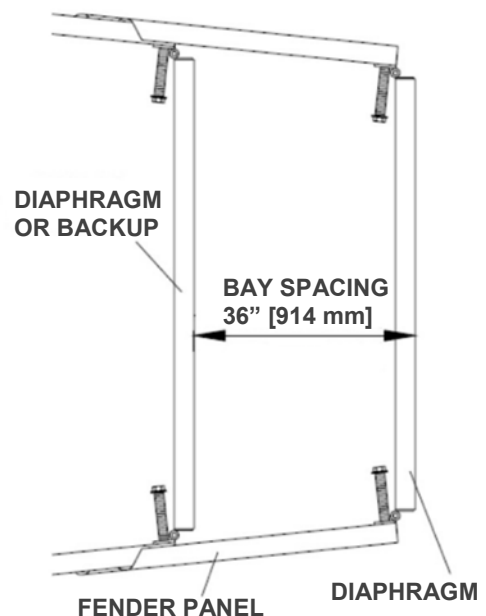

**Figure 28**  
**Proper Diaphragm Spacing**

**9) Attach End Cap**

Attach the End Cap to the front of the first Monorail segment, as shown below and the Monorail Assembly drawing.

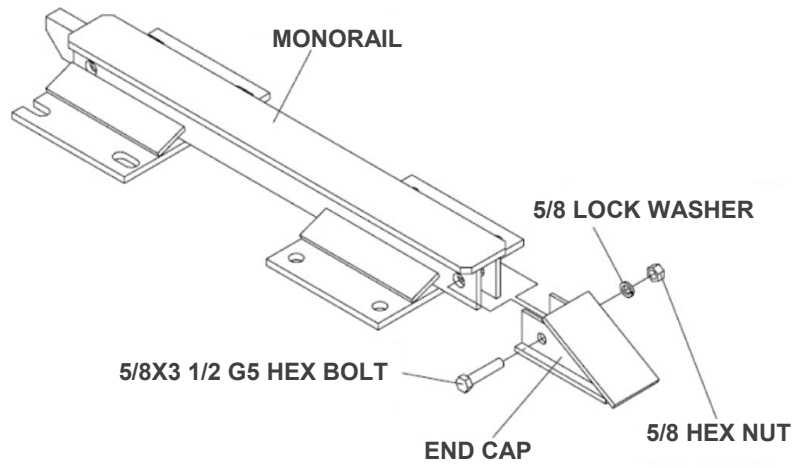

**Figure 29  
Monorail End Cap Attachment**

9) **Attach Lower Cartridge Support Brackets**

Attach lower Cartridge Support Bracket to the front and back of all Diaphragms and also to the front of the Backup as shown below.

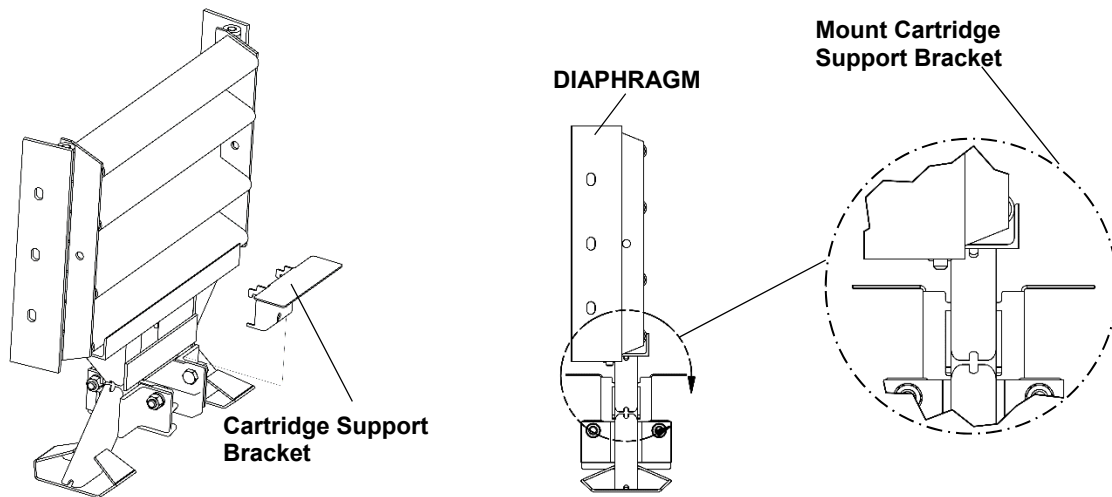

**Figure 30**  
**Lower Cartridge Support Bracket Assembly**

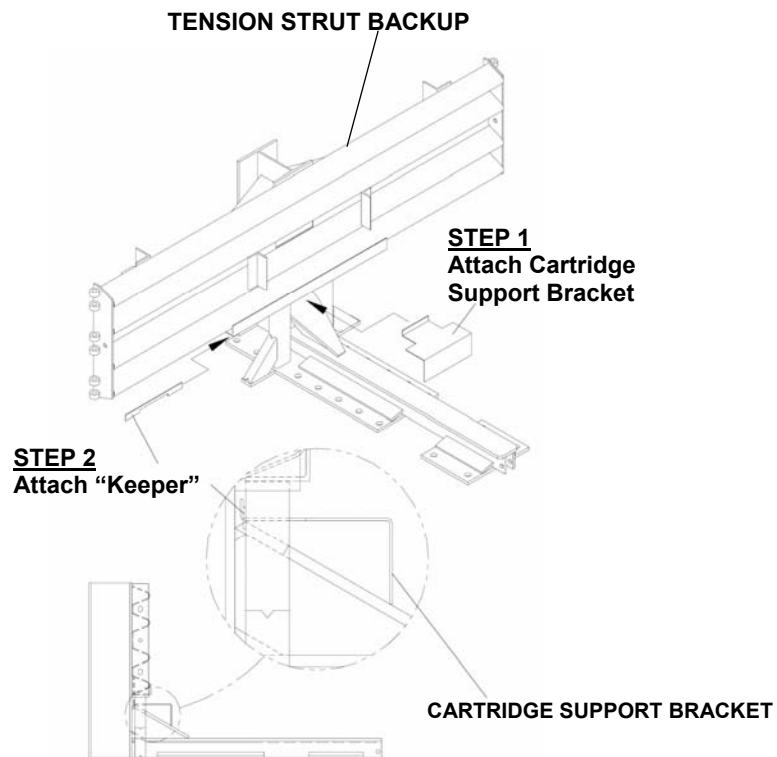

**Figure 31**  
**Cartridge Support Bracket Assembly**  
**(Tension Strut Backup)**



## 10) Nose Assembly

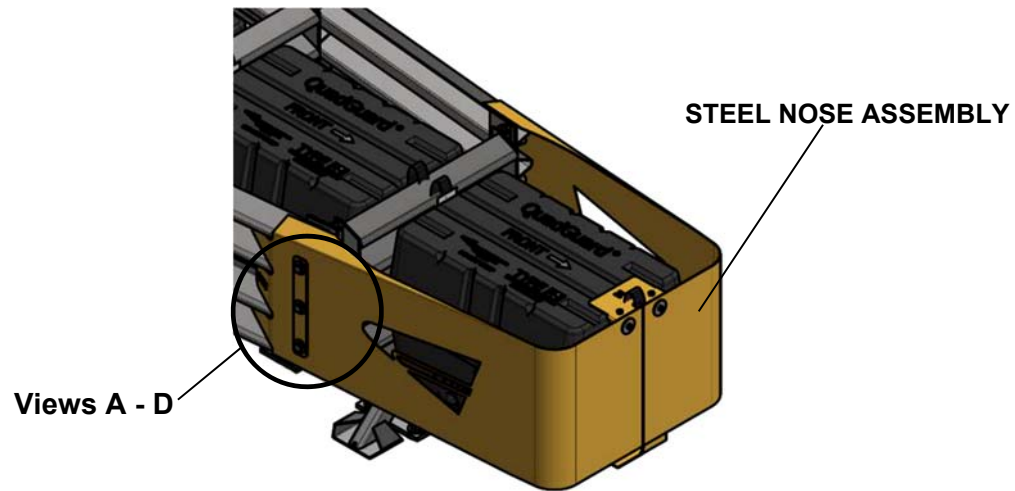

**Figure 32**  
**NOSE ASSEMBLY (p. 51)**

- A. Pre-assemble each Nose Assembly half with 5/8X5" hex bolt, 5/8X1 3/4" flat washer, bar washer, 3/4" schedule 80 pipe, and 5/8" rail nut (three (3) places per half (Detail A & B)). Tighten.
- B. Join both pre-assembled Nose halves with Cartridge Support Nose Bracket using 1/4X3/4" hex bolts and nuts in six (6) places (Detail B & C). Tighten.
- C. Fasten Pull-Out Brackets to front Diaphragm with 5/8X2" hex bolts and rail nuts. Tighten (Detail D & E).
- D. Attach Nose to Fender Panel and Diaphragm Hinge Plates with 5/8" rail nuts. Adjust Nose assembly height so top front Nose is 32 1/8" above the concrete pad. Tighten all six (6) nuts (Detail F & G).
- E. Install Type I Cartridge insuring directional arrow is pointing to front of system.
- F. Attach Hold Down Bracket to front of Nose with 5/8" fasteners (p. 34).

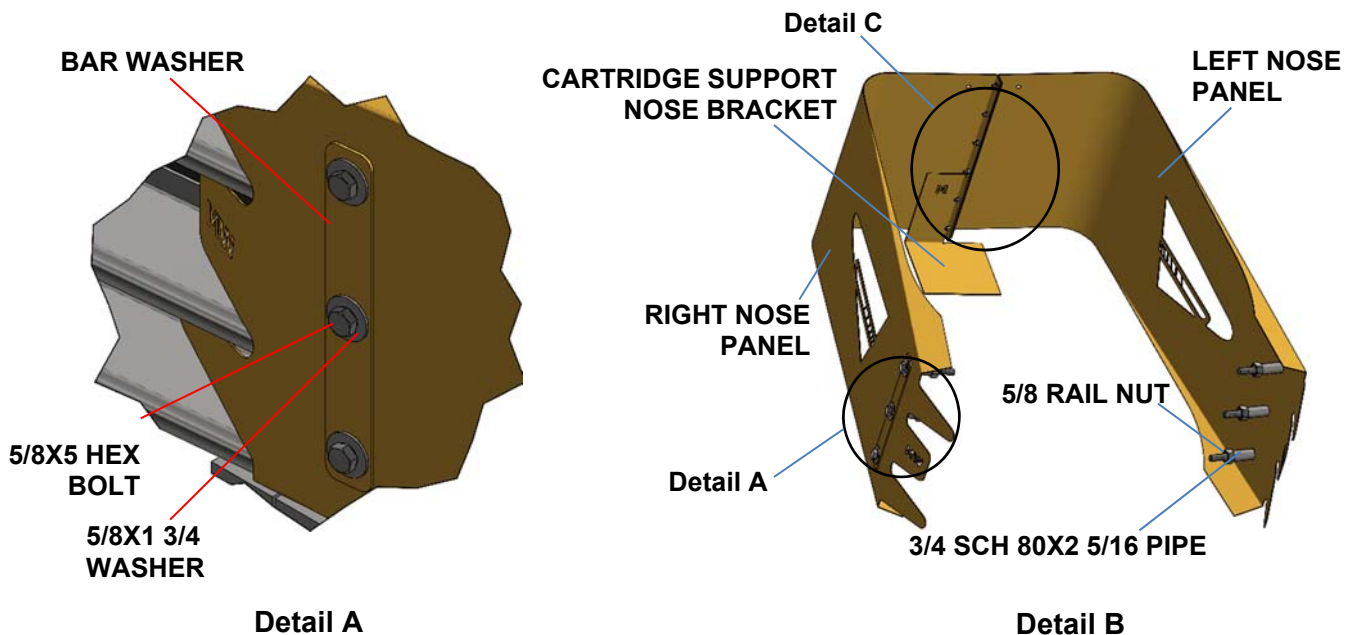

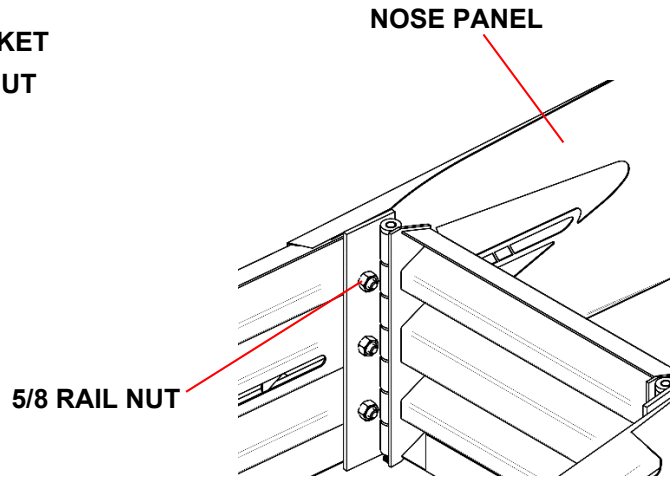
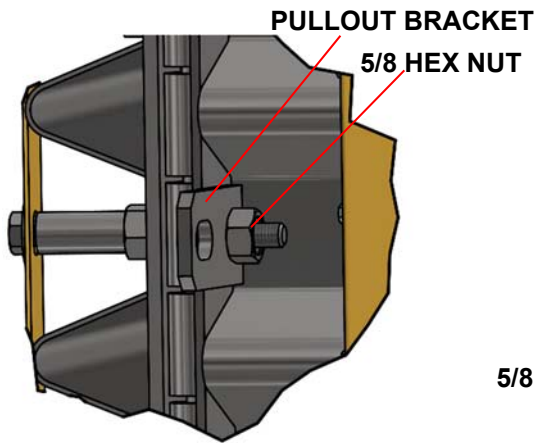
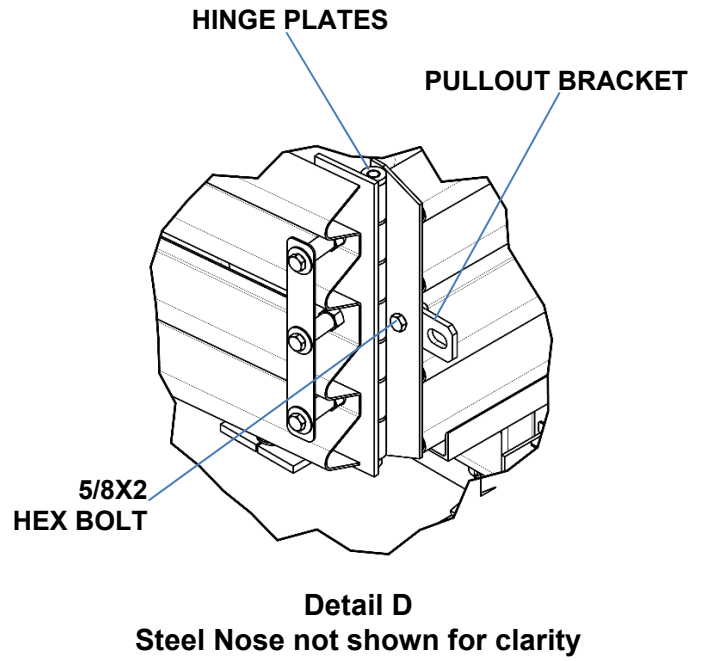
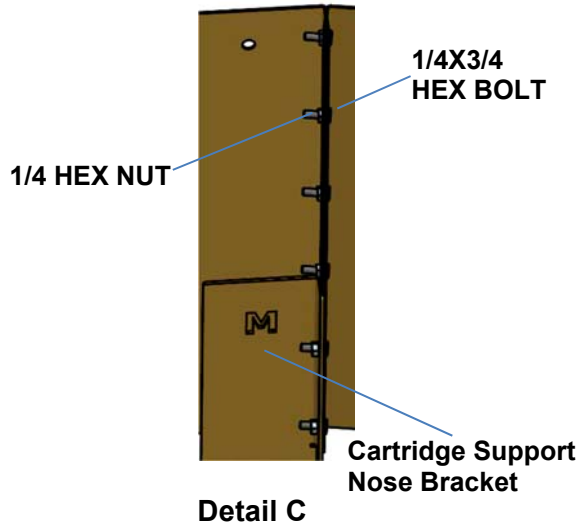

Note: Detail G shows proper placement of Cartridge Nose Support Bracket.

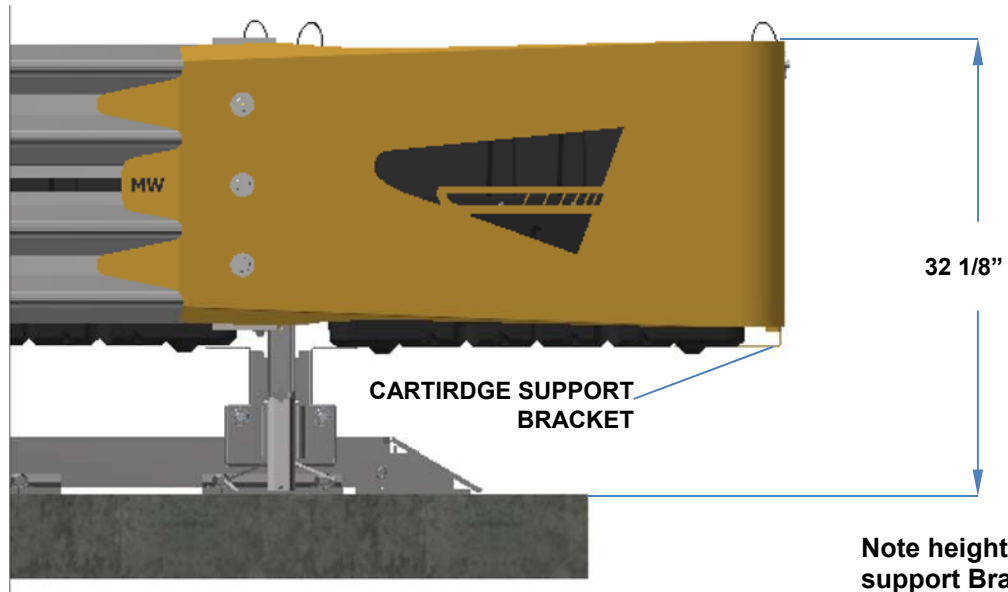

Detail G

Note height of Cartridge support Bracket. The Cartridge sits at the same level as the other Bays to the rear.

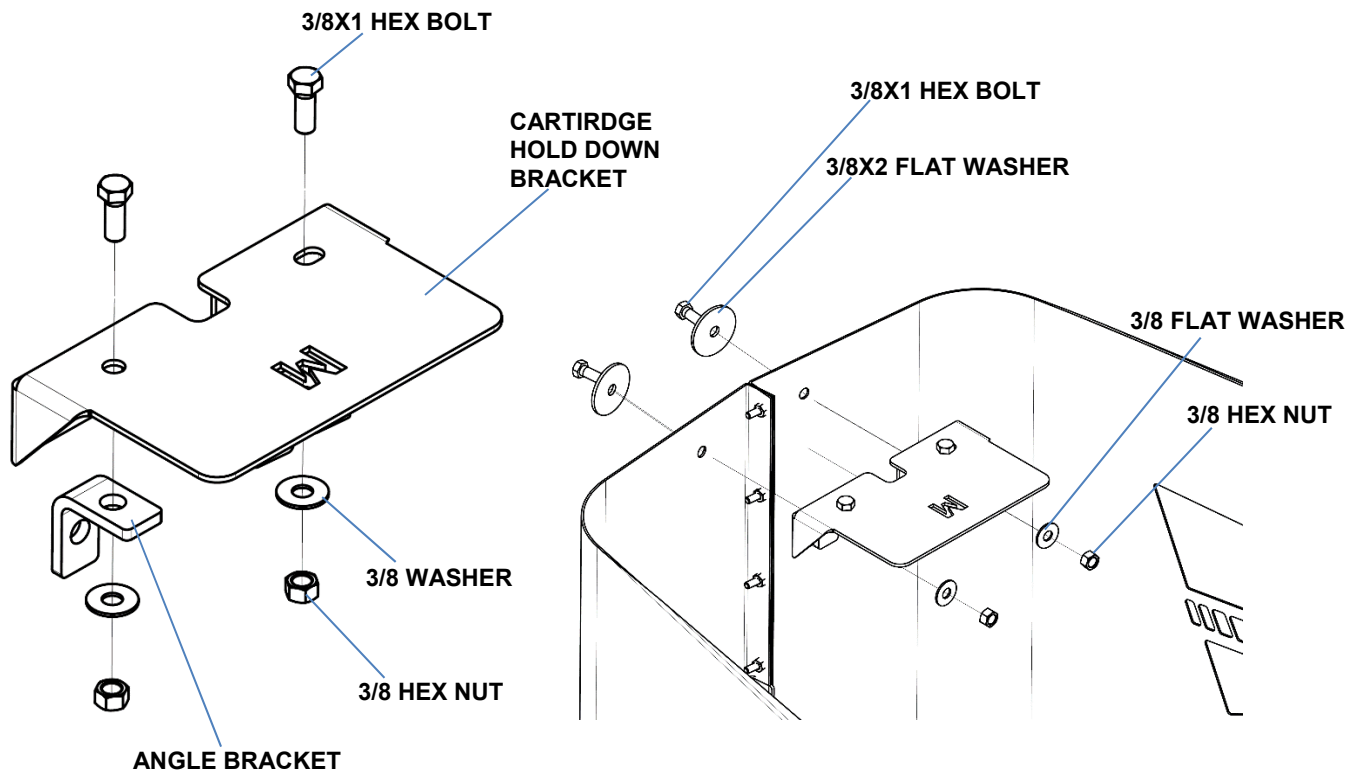

Figure 33  
Hold Down Bracket Assembly

## 11. Checking the System Assembly

Ensure all fasteners are properly tightened throughout the system (anchor bolts, etc.). See torque requirements below. Check all Fender Panels. If they do not fit tightly against the underlying Panel, system realignment may be necessary (Figure 34).



**Important:** Top of Steel Nose is 32 1/8" above grade (p. 34).



Warning	
<b>Anchor Torque and Clearance Requirements</b>	
Torque Requirements – Adhesive Manufacture Spec Anchor clearance above nuts – Figure 18, p. 24	
<b>Fender Panel Critical Clearances</b>	
Fender Panel Gap Wide – 1.00" [25 mm]	

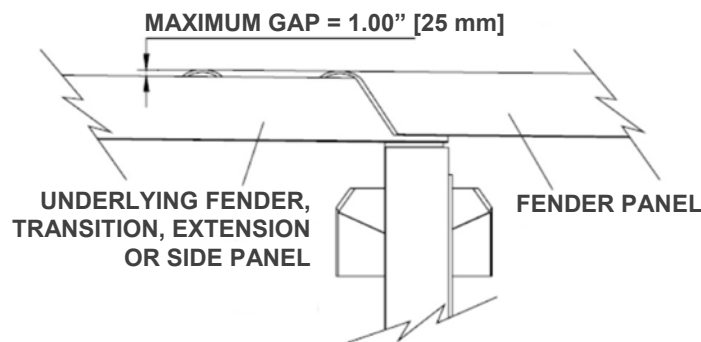

**Figure 34**  
**Fender Panel Gap**

## 12) Cartridge Placement

The Nose Cartridge must be the same height as every other Cartridge. To complete the assembly of a QuadGuard® M Wide, place the appropriate Cartridge in each Bay of the system. Type I Cartridges are placed toward the front (Nose) of the system; Type II Cartridges are placed toward the rear (Backup) of the system (p. 20).



**Warning:** Placing the wrong Cartridge in the Nose or Bay(s) could result in unacceptable crash performance per MASH criteria and cause serious injury or death to occupants and/or bystanders in the event of a vehicle impact.



**Important:** The QuadGuard® M Wide is a six (6) Bay configuration.

## **QuadGuard® M Wide Final Inspection Checklist**

Site Location: \_\_\_\_\_

Date: \_\_\_\_\_

Inspector: \_\_\_\_\_

**Refer to the QuadGuard® M Wide manual and / or drawing package.**

- Clearance of 25" behind rear Fender Panels for stroke (p. 13)
- Anchor nuts are torqued to manufacturer specification (p. 17)
- Cartridges are level and the same height in each Bay (p. 20)
- Correct Cartridge is placed in each Bay and pointing to front of system (p. 20)
- Every hole and slot in Backup and Monorail is anchored (pp. 23, 24)
- If no transition, side panels at backup are required (p. 25)
- Anchor stud(s) are 1.5" maximum above the pad) (p. 24)
- Monorail guides are attached to Diaphragms (p. 26)
- Diaphragm Shims installed between Diaphragm & Monorail guides (p. 26)
- Each Fender Panel has a tension Die Spring (p. 28)
- Mushroom Washers seated in slots (p. 29)
- Monorail has End Cap attached (p. 30)
- Front of the Nose assembly is 32 1/8" above concrete pad (p. 34)
- Nose Cartridge is at the same height as Bay Cartridges (p. 34)
- Cartridge Hold Down Bracket is secure and engaged with Nose Cartridge (p. 34)
- Fender Panel gap is maximum of 1.00" [25 mm] (p. 35)
- Bolts and nuts are properly tightened (p. 35)
- System is clear of debris

## **Maintenance and Repair**

### **Inspection Frequency**

Inspections for QuadGuard® M Wide are recommended as needed based upon volume of traffic and impact history. Visual Drive-By Inspections are recommended at least once a month. Walk-Up Inspections are recommended at least once a year.

### **Visual Drive-By Inspection**

- 1) Is there is evidence of an impact? If so, perform a walk-up inspection.
- 2) Are Cartridges properly seated on the Support Brackets? All damaged Cartridges must be replaced.



**Warning:** See Cartridge placement instructions on page 20.

- 3) Steel Nose is properly attached and 32 1/8" above grade (p. 34).
- 4) Note the location and condition of the QuadGuard® M Wide and the date of visual drive-by inspection.

### **Walk-Up Inspection Checklist**

- Clear and dispose of on-site debris.
- Clear and remove excessive dirt from around the Monorail and Diaphragm feet.
- Bolts are tight and rust free.
- Anchor bolts are securely anchored.
- Diaphragm Legs are straight.
- All Mushroom Washer Assemblies are flat and properly seated through Fender Panel slot.
- Fender Panels and Transition Panels should nest tightly against the system.
- Cartridges have not been damaged and are properly seated on their Support Brackets. To ensure intended speed characteristics, partially crushed Cartridges (due to low speed impacts) must be replaced.
- Make all necessary repairs as described above. See Post-Impact Instructions for more information on next page.
- To determine if a product should be replaced or is potentially reusable, a trained engineer experienced in highway products and directed by the DOT, or other appropriate local highway authority, must be consulted.

## Post-Impact Instructions



**Important:** Trinity Highway makes no recommendation whether use or reuse of any part of the system is appropriate or acceptable following an impact. It is the sole responsibility of the local highway authority and its engineers to make that determination. It is critical that you inspect this product after assembly is complete to make certain that the instructions provided in this manual have been strictly followed.

- 1) Deploy appropriate traffic-control devices.
- 2) Ensure all anchor bolts have remained firmly anchored in the roadway surface. Replace any loose, broken, or pulled out anchors.

**The performance of the system during an angle impact depends on a properly anchored Monorail.**

- 3) Clear and dispose of any debris on site.
- 4) Ensure the Mushroom Washer Assemblies are intact so the system can be restored to its original position.



**Caution:** Use eye protection and gloves when refurbishing the Mushroom Washer Die Spring Assembly. Do not place fingers underneath an assembled Mushroom Washer. Parts may suddenly shift and fingers may be pinched. If the Die Spring is still under compression as the nut is nearing the end of the bolt, to prevent injury make sure that the Die Spring is restrained with a clamp so it does not suddenly release when the nut is removed from the Mushroom Washer Bolt.

- 5) The Diaphragm Support Legs are all properly attached to the Monorail.
- 6) Remove the Nose Assembly and attach a chain to the Pullout Brackets on the first Diaphragm (Figure 35). Attach both ends of chain to a heavy vehicle (such as a 1 ton pickup).



**Warning:** Stand clear in case chain breaks or becomes disconnected.

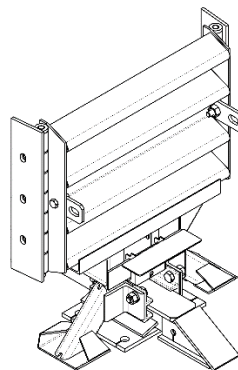

**Figure 35**  
**Pullout Brackets**



**Important:** Slowly pull the system forward to its original length. Have someone watch the repositioning to ensure undetected damage does not cause the Diaphragms to bind or pull out improperly.

- 7) Remove all crushed Cartridges.
- 8) All Diaphragms are in usable condition. Diaphragms which are bowed or have bent legs must be replaced.
- 9) Each Fender Panel is properly attached with Mushroom Washer Assemblies. Damaged Fender and Transition Panels must be replaced.



<b>Warning</b>	
<b>Anchor Torque and Clearance Requirements</b>	
Torque Requirements – Adhesive Manufacturer Spec Anchor clearance above nuts – Figure 18, p. 24	
<b>Fender Panel Critical Clearances</b>	
Fender Panel Gap– 1.00” [25 mm]	

- 10) Check the **gaps between Fender Panels**. The maximum gap allowed for these overlapping parts (including Fender Panels overlapping Panels behind the system) is 1.00” [25 mm].



**Important:** Ensure the Mushroom Washer rail nuts are tightened to the end of the bolt threads. If the gaps between the Fender Panels are still too large, it may be necessary to replace bent parts.

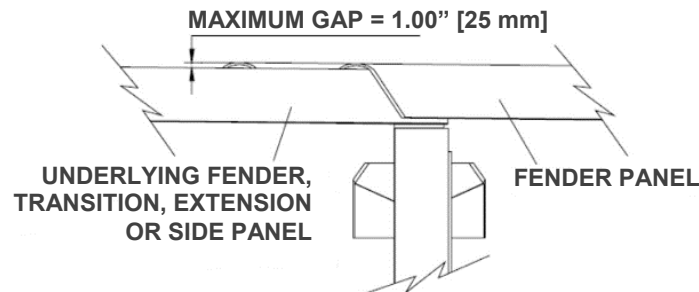

**Figure 36**  
**Fender Panel Gap**

- 11) Replace all crushed Cartridges and damaged Cartridge Support Brackets. See Cartridge Placement on page 20.
- 12) Remove damaged Nose Assembly. Attach the new Nose to the first Diaphragm. See pages 32 - 34 and 51 for Nose attachment instructions.
- 13) All bolts on the system are adequately tight.
- 14) Site is free from debris.
- 15) The QuadGuard® M Wide is now ready for use.



## Parts Ordering Procedure & Drawings

Make a list of all damaged parts from the System Components section in this manual (p. 7 – 11). Answer the following questions in the spaces provided. This information is necessary to receive the proper parts.

<b>QuadGuard® M Wide Ordering Information Chart</b>		
<b>Description:</b>	<b>Choices</b>	<b>Fill in this section</b>
<b>Transition Panel Type?</b>  Side Panel and Transition Panel Types are on page 12. Include Transition options for both sides if necessary. How to Determine Left/Right is on page 21.	<ul style="list-style-type: none"> <li>• Quad to W-Beam Guardrail</li> <li>• Quad to Thrie Beam Guardrail</li> <li>• Quad to Safety Shape Barrier</li> <li>• Quad to Single Slope Barrier</li> <li>• Quad to Vertical Concrete End Shoe</li> <li>• None</li> </ul>	

### Parts List(s) & Quantities

<b>PN</b>	<b>Description</b>	<b>Count</b>
118710	Adhesive, HY200, 330, Hilti	14
627511	Backup, TS, 64, M Wide, W/Decals	1
113518	Bolt, Hex, 1/4x3/4, G5	6
113508	Bolt, Hex, 1/4x1, G5	2
113596	Bolt, Hex, 3/8x1, G5	4
113612	Bolt, Hex, 3/8x3 1/2, All Thread, G5	16
118570	Bolt, Hex, 5/8x2, G5	2
113660	Bolt, Hex, 5/8x3 1/2, G5	1
113666	Bolt, Hex, 5/8x4, G5	36
119163	Bolt, Hex, 5/8x5, G8, P, F/T	6
113555	Bolt, Hex, 3/4x2, G8	24
003400	Bolt, Rail, 5/8x2	28
626817	Bracket, Angle, 2X1,W/Holes	2
626815	Bracket, Cartridge Hold Down	1
626816	Bracket, Cartridge Support, Nose	1
605446	Bracket, Cartridge Support, Dia, Folded	12
605447	Bracket, Cartridge Support, TS B/U	1
605535	Bracket, Pull-Out	2
606027	Cartridge Assembly, Type I	4
606029	Cartridge Assembly, Type II	3
607771	Diaphragm, 0833	1
607775	Diaphragm, 0993	1
607780	Diaphragm, 1153	1
607788	Diaphragm, 1313	1

PN	Description	Count
607796	Diaphragm, 1473	1
627532	Diaphragm, Full Length,0673	1
608136	Endcap, Monorail	1
627525	Hinge Pin, Dia, Full Length	2
610172	Hinge Plate, Fender Panel	12
627524	Hinge Plate, Full Length	2
611266	Locking Bar, Cartridge Support	1
611368	Monorail Guide	12
611375	Monorail, 2 Bays	1
611379	Monorail, 3 Bays	1
627513	Nose, Left Half	1
627514	Nose, Right Half	1
003704	Nut, Heavy Hex, 3/4, A563 DH	80
003354	Nut, Heavy Hex, 5/8, A563	37
115946	Nut, Hex, 1/4	8
115960	Nut, Hex, 3/8	20
003340	Nut, Hex, 5/8, Rail	54
611832	Panel, Fender	12
611900	Panel, Side	2
626819	Pipe, 3/4 Schedule 80X2 5/16	6
116879	Screw, Flat, 5/8X8 1/2, G8, Socket	12
614062	Shim, 12GAX3 5/8X8	12
117458	Spring, Die, 1 1/2 ODX3/4X6	12
117542	Stud, 3/4X7, G5	56
615756	Tel ST 1 3/4X1 3/4X12GAX10, H4S	4
615765	Tel ST 2X2X12GAX10, H4S	4
626818	Washer, Bar, 10GAX2X14, Slots	2
118027	Washer, Flat, 3/4X2, Heavy	56
118036	Washer, Flat, 3/8X1	4
118038	Washer, Flat, 3/8X2	2
003300	Washer, Flat, 5/8X1 3/4	6
118089	Washer, Lock, 3/4	24
118092	Washer, Lock, 3/8	16
118100	Washer, Lock, 5/8	37
617045	Washer, Mushroom, Forged	12



**Warning:** Use only Trinity Highway parts that are specified herein for assembling, maintaining, or repairing the QuadGuard® M Wide. **Do not utilize or otherwise comingle parts from other systems even if those systems are other Trinity Highway systems.** Such configurations have not been tested, nor have they been deemed eligible for use. Assembly, maintenance, or repairs using unspecified parts or accessories is strictly prohibited.



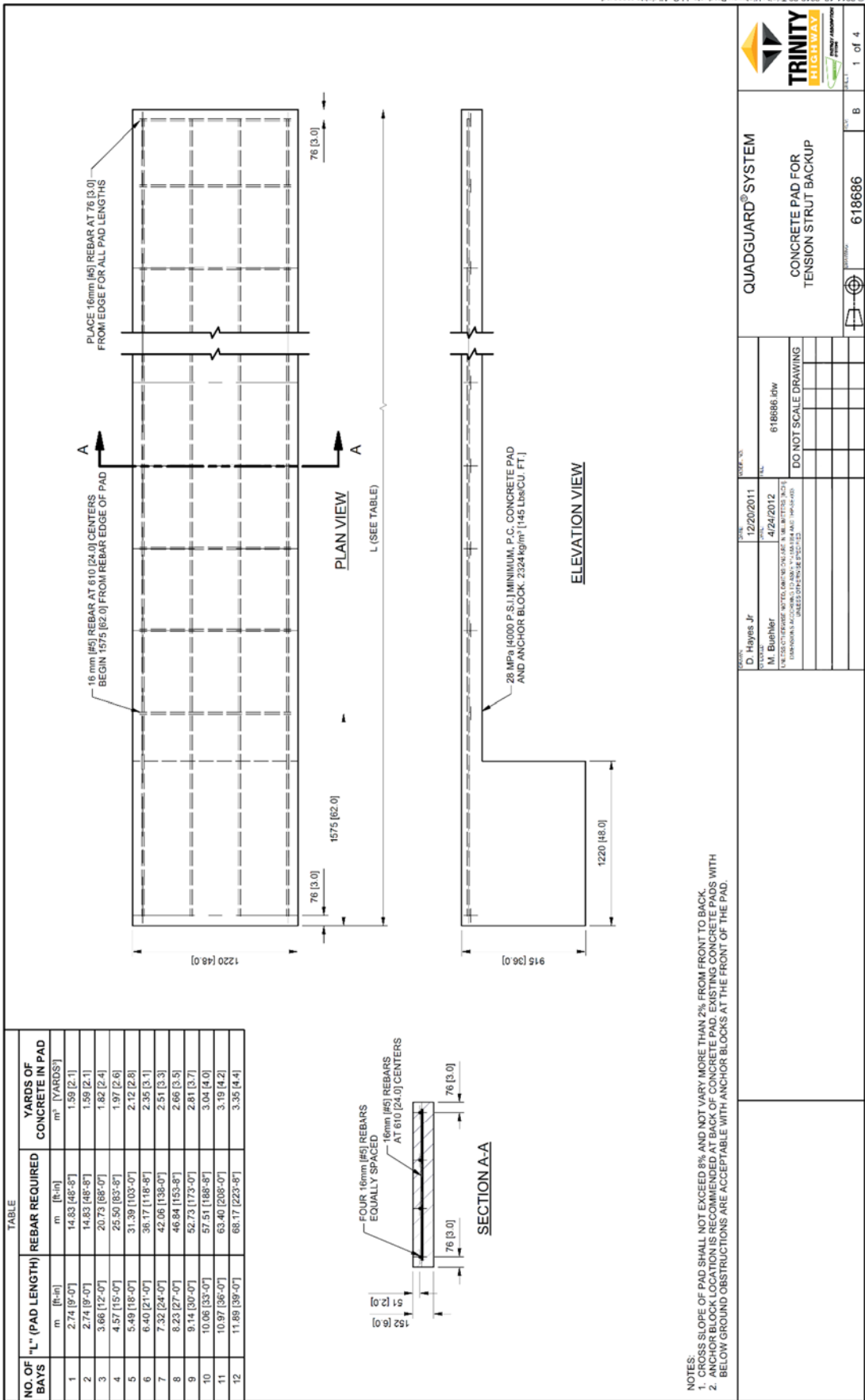

NOTES:  
 1. GROSS SLOPE OF PAD SHALL NOT EXCEED 8% AND NOT VARY MORE THAN 2% FROM FRONT TO BACK.  
 2. ANCHOR BLOCK LOCATION IS RECOMMENDED AT BACK OF CONCRETE PAD. EXISTING CONCRETE PADS WITH BELOW GROUND OBSTRUCTIONS ARE ACCEPTABLE WITH ANCHOR BLOCKS AT THE FRONT OF THE PAD.

		<b>QUADGUARD® SYSTEM</b> CONCRETE PAD FOR TENSION STRUT BACKUP	
DRAWN BY D. Hayes Jr. CHECKED BY M. Buehler	DATE 12/20/2011 DATE 4/24/2012	PROJECT NO. 618686 low	SHEET NO. 1 of 4
LICENSED PROFESSIONAL ENGINEER MICHIGAN LICENSE NO. 94044 REGISTERED PROFESSIONAL ENGINEER		DO NOT SCALE DRAWING	
PROJECT NO. 618686		SHEET NO. 1 of 4	

Concrete Pad 618686

SYSTEM	WIDTH	7" ANCHOR	18" ANCHOR	NO ANCHOR
OG, QGH, QGHS	69"	604598	626520	627519
OG, QGH, QGHS	90"	604599	626521	627520
OG M WIDE	69"	627512	N/A	627523

PARTS LIST	
ITEM	DESCRIPTION
1	BACKUP TS, WIDE, WIDE/CAL
2	PANEL SIDE, OG, WIDE, G
3	BOLT, HK, 3/8X3 1/2 ALL THREAD, GS, G
4	NUT, HK, 3/8, G
5	WASHER, LOCK, 3/8, G
6	ANCHOR KIT, HILT, 1.350ml, 3/4X7, (4)
7	NUT, HK, 5/8, G, RAIL
8	BOLT, RAIL, 5/8X2, G
9	BOLT, HK, 5/8X4, GS, G
10	WASHER, LOCK, 5/8, G
11	5/8" HVY HEX NUT A563A
12	HINGE PLATE FENDER PANEL, OG
13	TEL ST, 1 3/4X1 3/4X12 GA X10 HAS, G
14	TEL ST, 2X2X12 GA X10 HAS, G
15	BRACKET, CART, SUPT, TS, B, U, OG
16	LOCKING BAR, CARTRIDGE SUPT, OG

**QUADGUARD FAMILY**

**Tension Strut Backup      627528**

**QUADGUARD® FAMILY**  
BACKUP ASSEMBLY, TENSION STRUT

DATE: 2/18/2020    TIME: 10:08:15  
 DRAWN BY: D. Kohfeld    NO: 627528.dwg  
 CHECKED BY: B. Eckert    DATE: 2/25/2020  
USE ISO PREFERRED UNITS (MILLIMETERS) UNLESS OTHERWISE SPECIFIED.  
 DIMENSIONS IN PARENTHESES ARE APPROXIMATE.

DO NOT SCALE DRAWING

PROJECT: 627528    SHEET: 1 of 2

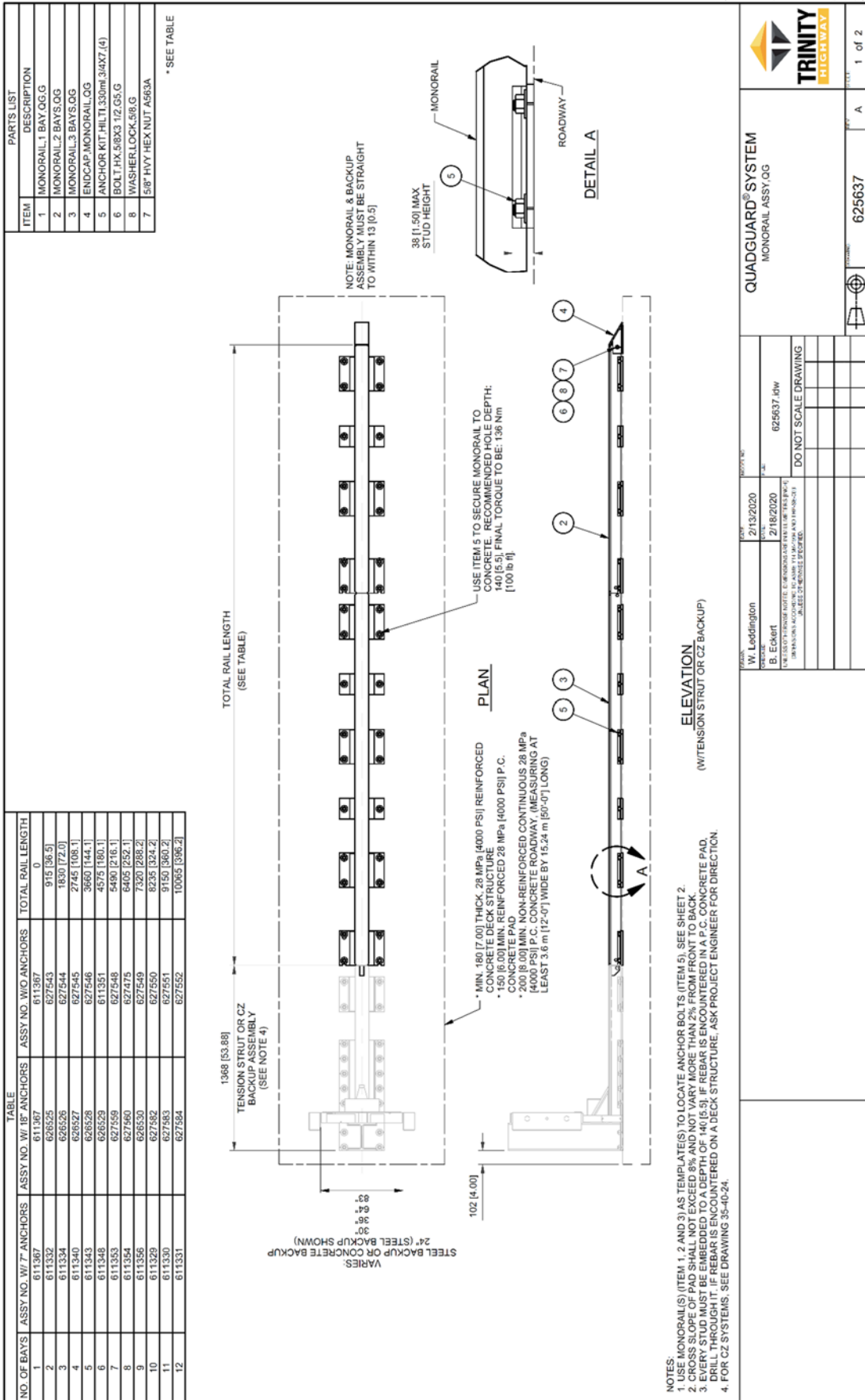

# Monorail Assembly 625637

	<b>QUADGUARD® SYSTEM</b> MONORAIL ASSY, OG	625637	1 of 2
DESIGNER: W. Leedington DATE: 2/13/2020 CHECKER: B. Eckert DATE: 2/18/2020 SCALE: AS SHOWN DO NOT SCALE DRAWING			

ITEM	DESCRIPTION
1	DIAPHRAGM,08,FULL LENGTH
2	WASHER,LOCK,3/4,G
3	BOLT,HX,3/4X2,08,G
4	MONORAIL GUIDE,0G,G
5	3/4" Hvy HEX NUT A563 DH
6	BRACKET,CAR SUPT DIA,FOLDED,0G
7	HINGE PLATE,FULL LENGTH,FNDR PNL,0G
8	HINGE PIN,DIA,FULL LENGTH
9	BOLT,HX,1/4X1,G5,G
10	NUT,HX,1/4,G

**BAY 1 DIAPHRAGM**

TABLE	
ASSEMBLY	WIDTH
627536	673 [26.5]

<b>QUADGUARD® QG M WIDE</b>	<b>DIAPHRAGM ASSEMBLY</b>	<b>627534 idw</b>	<b>DO NOT SCALE DRAWING</b>
D. Kohfeld B. Eckert 2/20/2020 2/25/2020 627534 idw QUADGUARD ASSEMBLY QUADGUARD ACCESSORIES TO ASSEMBLY PARTS AND TOOLS IN THIS SET-UP ARE NOT SHOWN		DATE 2/20/2020 DATE 2/25/2020 DRAWING NO. 627534 idw DO NOT SCALE DRAWING	SCALE 1 of 3 SHEET NO. 1 of 3

## Diaphragm Assembly 627534

ITEM	DESCRIPTION
1	DIAPHRAGM,OR
2	WASHER,LOCK,3/4,G
3	BOLT,HX,3/4X2,GR,G
4	MONORAIL, GUIDE,OG,G
5	3/4" HVY HEX NUT A563 DH
6	BRACKET,CART,SUPT,DIA,FOLDED,OG
7	HINGE PLATE,FENDER,PANEL,OG
8	BOLT,HX,5/8X4,65,G
9	5/8" HVY HEX NUT A563A
10	WASHER,LOCK,5/8,G

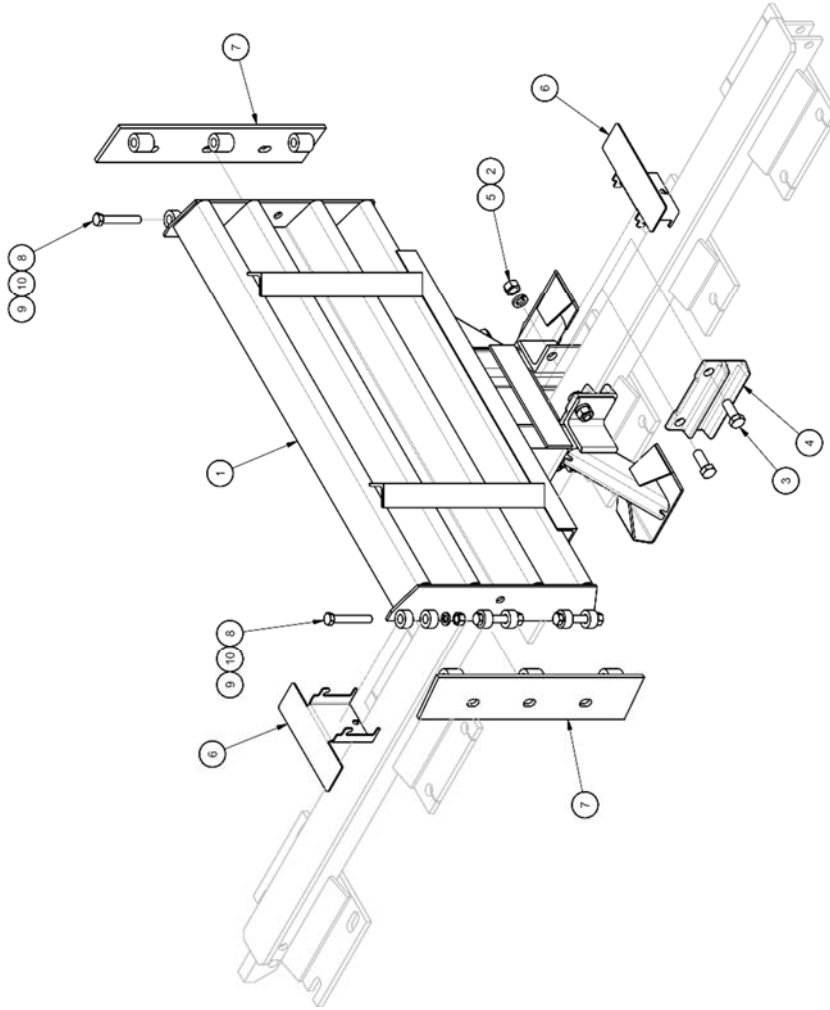

STANDARD DIAPHRAGMS

ASSEMBLY	WIDTH
607175	833 [32.8]
607177	993 [39.1]
607146	1153 [45.4]
607150	1313 [51.7]
607152	1473 [60.0]

**QUADGUARD® QG M WIDE**  
DIAPHRAGM ASSEMBLY

DATE: 2/20/2020  
BY: D. Kohfeld

DATE: 2/25/2020  
BY: B. Eckert

UNLESS OTHERWISE NOTED, ALL DIMENSIONS ARE IN UNITS OF INCHES.  
DIMENSIONS IN PARENTHESES ARE IN UNITS OF MILLIMETERS.

DO NOT SCALE DRAWING

TRINITY HIGHWAY

FILE: 627534



REV: -

SHEET: 2 of 3

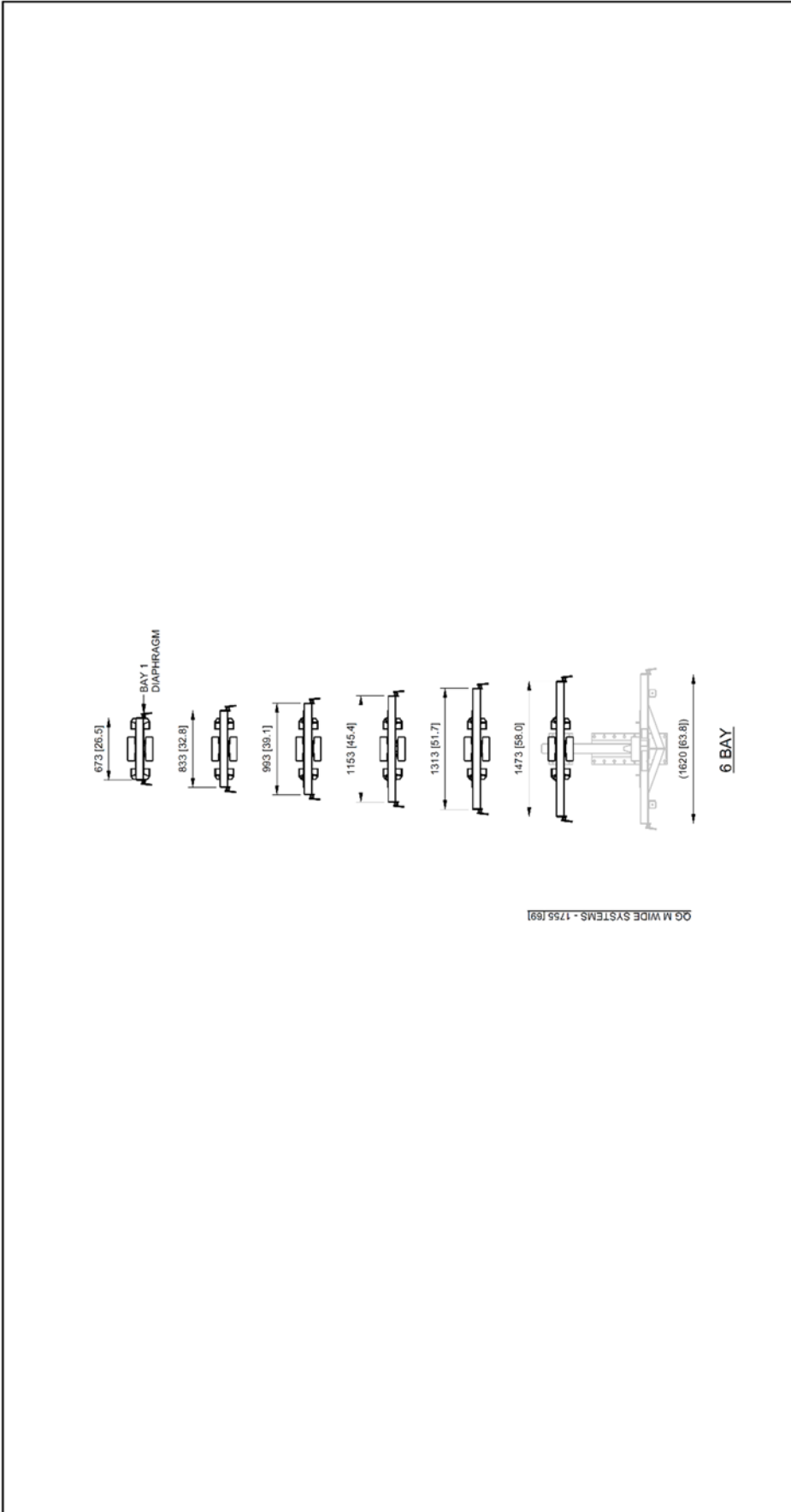

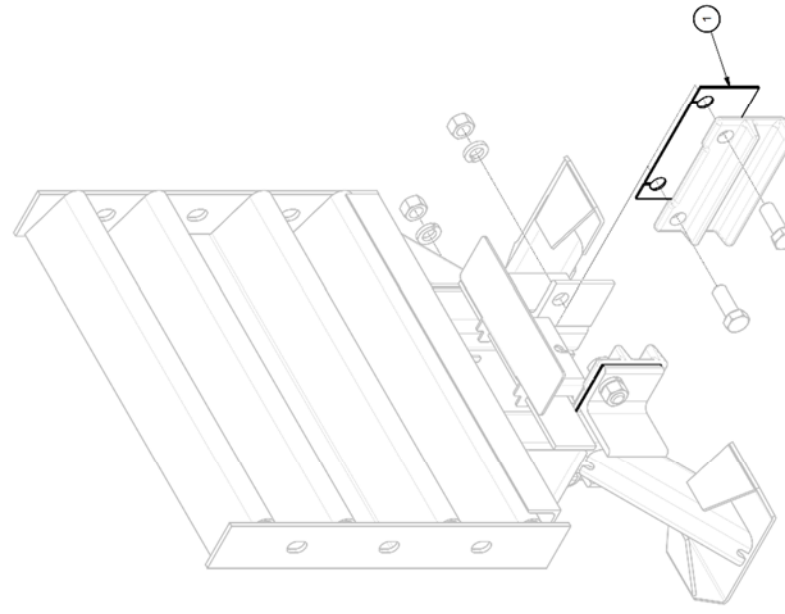

<b>QUADGUARD QG M WIDE</b> DIAPHRAGM ASSEMBLY			
DESIGN: D. Kohfeld CHECKED: B. Eckert <small>UNLESS OTHERWISE SPECIFIED, DIMENSIONS SHALL BE IN MILLIMETERS (INCHES). DIMENSIONS IN PARENTHESES ARE APPROXIMATE.</small>	DATE: 2/20/2020 DATE: 2/25/2020	DRAWING NO.: 627534.dwg	SHEET: 3 of 3
REVISION: INITIAL RELEASE	ECO: 6821 DATE: 2/26/20 REV: - BY: DK /	DO NOT SCALE DRAWING	PROJECT: 627534

PARTS LIST													
ITEM	DESCRIPTION												
1	SHIM.G												
													
		<table border="1" style="margin: auto;"> <tr> <th colspan="2">TABLE</th> </tr> <tr> <th>KIT</th> <th>THICKNESS</th> </tr> <tr> <td>614050</td> <td>12 GA.</td> </tr> </table>		TABLE		KIT	THICKNESS	614050	12 GA.				
TABLE													
KIT	THICKNESS												
614050	12 GA.												
				<b>QUADGUARD® FAMILY</b> SHIM KIT		REV. 1 of 1 627518							
D. Kohfeld 2/19/2020 627518.dwg DO NOT SCALE DRAWING													
<b>Shim Kit 627518</b>													

PARTS LIST			
ITEM	STOCK NO.	DESCRIPTION	QTY.
1	611832	PANEL,FENDER,OG	1
2	617045	WASHER,MUSHROOM,FORGED,OG,G	1
3	116879	SCREW,FL,5/8X8 1/2,GR,1/2,SOCKET	1
4	117458	SPRING,DIE,1 1/2 OD X3/4X8,GALV	1
6	003340	NUT,HX,5/8,G,RAIL	3
9	003400	BOLT,RAIL,5/8X2,G	2

TWO FENDER PANEL ASSEMBLIES REQUIRED PER BAY.

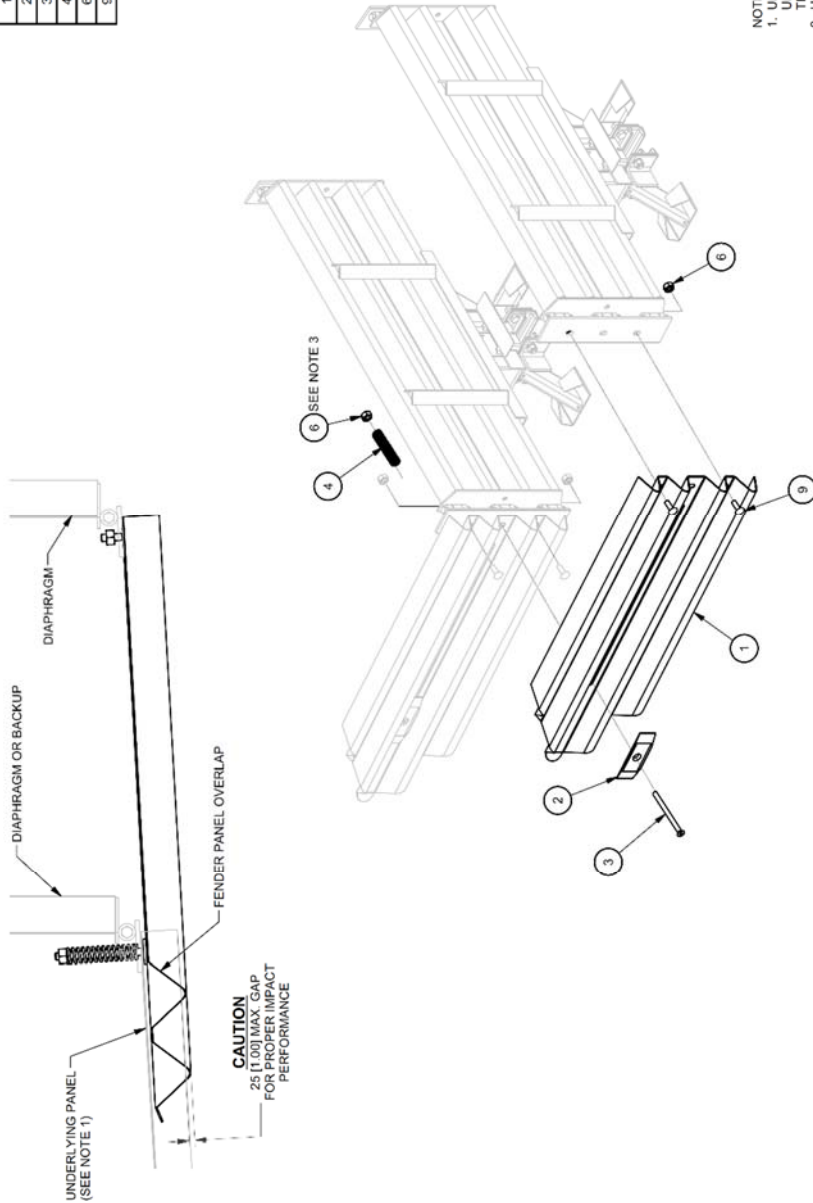

- NOTES:
1. UNDERLYING PANEL IS A FENDER PANEL IF ATTACHED TO A DIAPHRAGM. UNDERLYING PANEL IS A BACKUP SIDE PANEL, EXTENSION PANEL OR TRANSITION PANEL IF ATTACHED TO THE BACKUP.
  2. UNITS OF MEASUREMENT ARE MILLIMETERS (INCHES) UNLESS OTHERWISE NOTED.
  3. TIGHTEN NUT UNTIL IT REACHES END OF THREADS.

ASSEMBLY NO. 608241

QuadGuard - Wide System  
FENDER PANEL ASSEMBLY

SCALE	1 : 16	DRAWING NO.	608241	SHEET	1	OF	1	REV.	J
-------	--------	-------------	--------	-------	---	----	---	------	---

## Fender Panel Assembly 608241

DATE	6/12/1997
BY	D. Staus
DATE	4/10/1997
BY	J. Machado
DATE	7/7/1997
BY	KRM
DATE	7/7/1997
BY	J. Machado
FILE	608241.dwg

PARTS LIST	
ITEM	DESCRIPTION
1	NOSE LOG M WIDE
2	NOSE F LOG M WIDE
3	BRACKET CART SUPPORT, NOSE, QG M
4	BOLT, HX, 1/4X3/4, G5, G
5	BOLT, HX, 5/8X2, G5, G
6	NUT, HX, 1/4, G
7	NUT, HX, 5/8, G RAIL
8	BRACKET CART HOLD DOWN, LOG M
9	BRACKET ANGLE 2X1, WHOLES
10	WASHER, FLAT, 3/8X1, G
11	NUT, HX, 3/8, G
12	BOLT, HX, 3/8X1, G5, G
13	WASHER, FLAT, 3/8X2, G
14	BRACKET PULL-OUT, QG
15	PIPE 3/4 SCH 80X2, 5/16
16	BOLT, HX, 5/8X5, GR, P, FIT
17	WASHER, BAR, 1/2GX2X1/4, SLOTS
18	WASHER, FLAT, 5/8 X 1 3/4, G

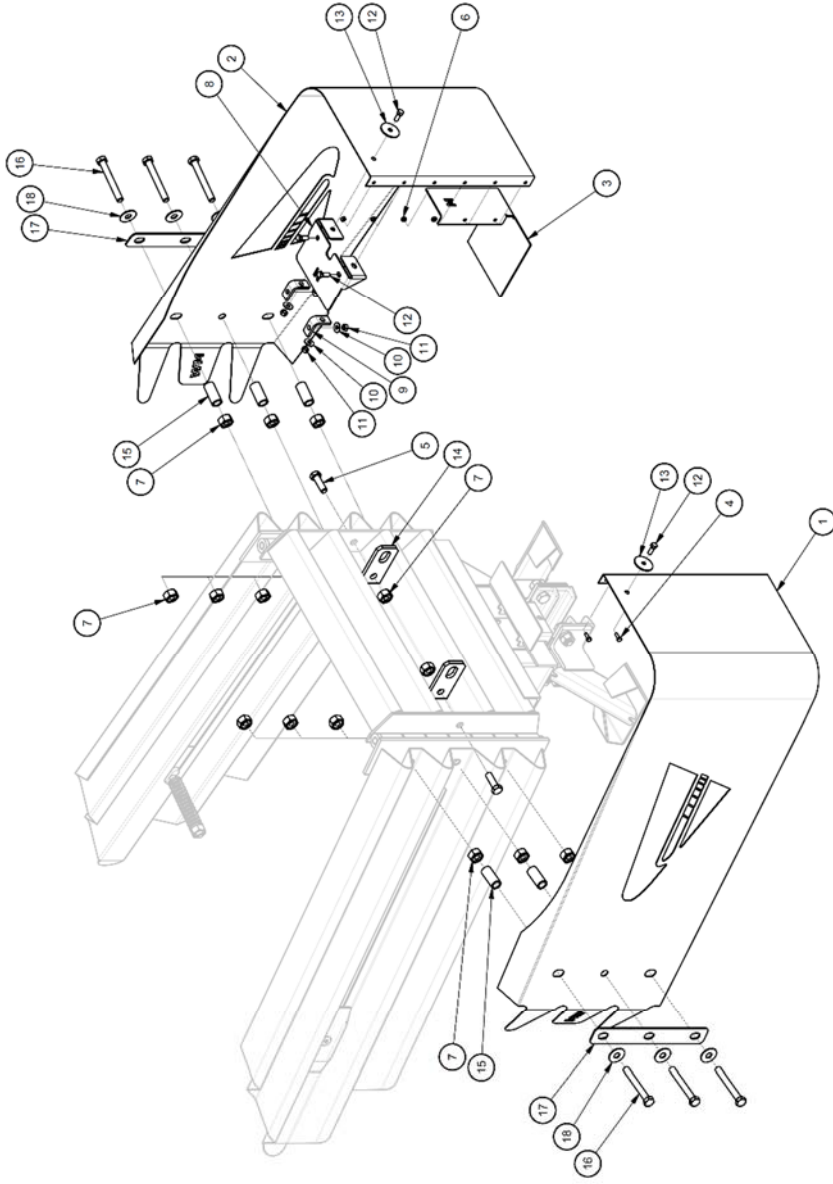

TABLE	
ASSEMBLY	COLOR
627516	BLACK
627517	GALVANIZED
627521	YELLOW

**QUADGUARD® QG M WIDE SYSTEM**  
NOSE ASSEMBLY

DATE: 2/17/2020  
DRAWN BY: D. Kotfield  
CHECKED BY: B. Eckert  
DATE: 2/25/2020  
UNLESS OTHERWISE NOTED, DIMENSIONS ARE IN MILLIMETERS (INCHES) IN PARENTHESES (INCHES)  
DIMENSIONS IN SQUARE BRACKETS ARE SUGGESTED

NO. 627522.dwg  
DO NOT SCALE DRAWING

1 of 1

**Nose Assembly 627522**

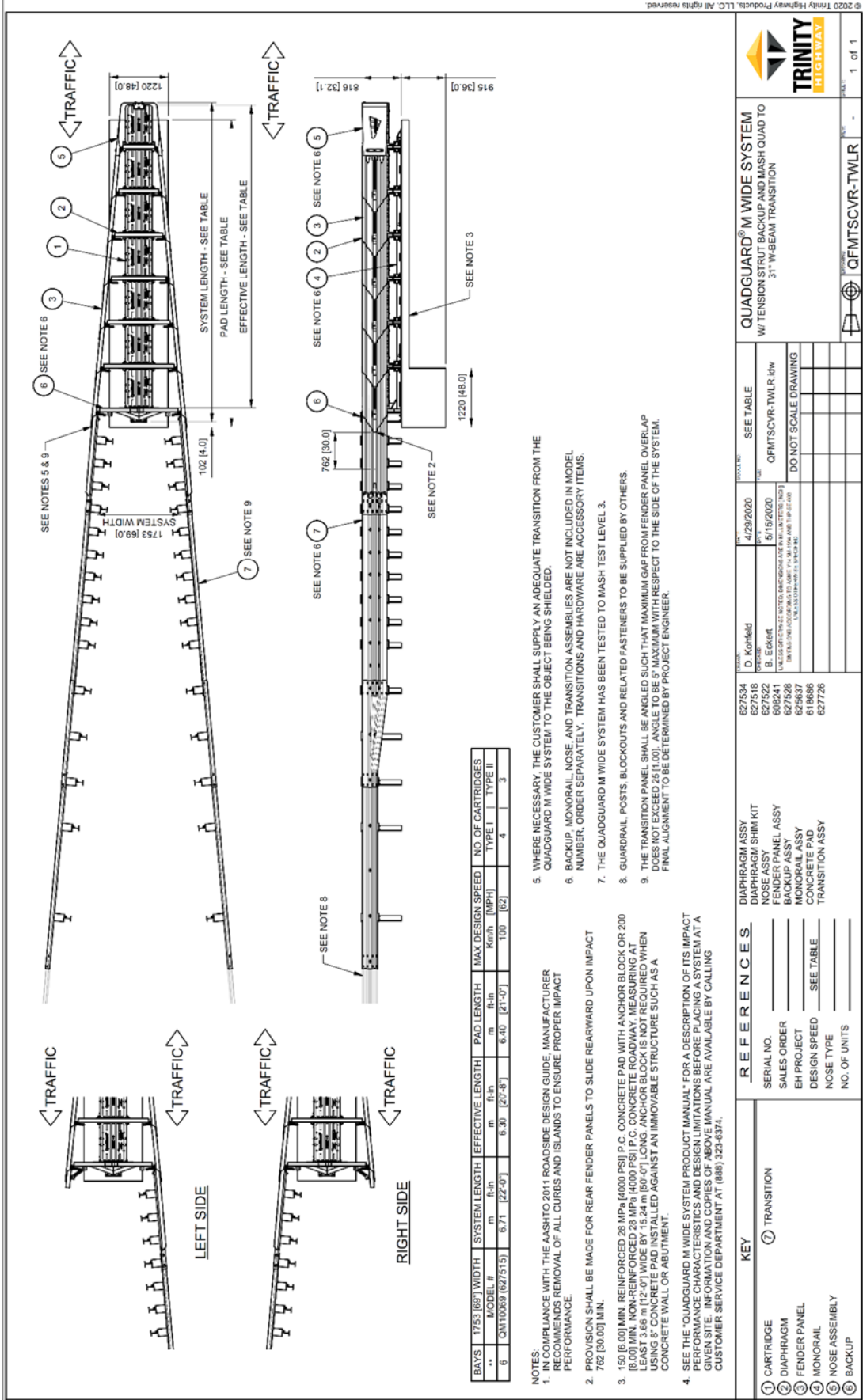

31" W-Beam Guardrail Transition QFMTCVR-TWLR



QUADGUARD® M WIDE SYSTEM  
W/ TENSION STRUT BACKUP AND MASH QUAD TO  
31" W-BEAM TRANSITION

DATE	BY	REV	DESCRIPTION
4/29/2020	D. Kohnfeld	1	SEE TABLE
5/15/2020	B. Eckert	2	QFMTCVR-TWLR Idw
DO NOT SCALE DRAWING			

NO.	DESCRIPTION	QTY
627534	DIAPHRAGM ASSY	
627522	NOSE ASSY SHIM KIT	
608241	FENDER PANEL ASSY	
627528	BACKUP ASSY	
625637	MONORAIL ASSY	
618686	CONCRETE PAD	
627726	TRANSITION ASSY	

REFERENCES:  
SERIAL NO. \_\_\_\_\_  
SALES ORDER \_\_\_\_\_  
EH PROJECT \_\_\_\_\_  
DESIGN SPEED \_\_\_\_\_  
NOSE TYPE \_\_\_\_\_  
NO. OF UNITS \_\_\_\_\_

KEY	DESCRIPTION
①	CARTRIDGE
②	DIAPHRAGM
③	FENDER PANEL
④	MONORAIL
⑤	NOSE ASSEMBLY
⑥	BACKUP

- WHERE NECESSARY, THE CUSTOMER SHALL SUPPLY AN ADEQUATE TRANSITION FROM THE QUADGUARD M WIDE SYSTEM TO THE OBJECT BEING SHIELDED.
- BACKUP, MONORAIL, NOSE, AND TRANSITION ASSEMBLIES ARE NOT INCLUDED IN MODEL NUMBER, ORDER SEPARATELY. TRANSITIONS AND HARDWARE ARE ACCESSORY ITEMS.
- THE QUADGUARD M WIDE SYSTEM HAS BEEN TESTED TO MASH TEST LEVEL 3.
- GUARDRAIL, POSTS, BLOCKOUTS AND RELATED FASTENERS TO BE SUPPLIED BY OTHERS.
- THE TRANSITION PANEL SHALL BE ANGLED SUCH THAT MAXIMUM GAP FROM FENDER PANEL OVERLAP DOES NOT EXCEED 25 (1.00)'. ANGLE TO BE 5° MAXIMUM WITH RESPECT TO THE SIDE OF THE SYSTEM. FINAL ALIGNMENT TO BE DETERMINED BY PROJECT ENGINEER.

- IN COMPLIANCE WITH THE AASHTO 2011 ROADSIDE DESIGN GUIDE, MANUFACTURER RECOMMENDS REMOVAL OF ALL CURBS AND ISLANDS TO ENSURE PROPER IMPACT PERFORMANCE.
- PROVISION SHALL BE MADE FOR REAR FENDER PANELS TO SLIDE REARWARD UPON IMPACT 762 (30.00) MIN.
- 150 (6.00) MIN. REINFORCED 28 MPa (4000 PSI) P.C. CONCRETE PAD WITH ANCHOR BLOCK OR 200 (8.00) MIN. NON-REINFORCED 28 MPa (4000 PSI) P.C. CONCRETE ROADWAY, MEASURING AT LEAST 3.66 m (12'-0") WIDE BY 15.24 m (50'-0") LONG. ANCHOR BLOCK IS NOT REQUIRED WHEN USING 8" CONCRETE PAD INSTALLED AGAINST AN IMMOVABLE STRUCTURE SUCH AS A CONCRETE WALL OR ABUTMENT.
- SEE THE "QUADGUARD M WIDE SYSTEM PRODUCT MANUAL" FOR A DESCRIPTION OF ITS IMPACT PERFORMANCE CHARACTERISTICS AND DESIGN LIMITATIONS BEFORE PLACING A SYSTEM AT A GIVEN SITE. INFORMATION AND COPIES OF ABOVE MANUAL ARE AVAILABLE BY CALLING CUSTOMER SERVICE DEPARTMENT AT (888) 323-6374.

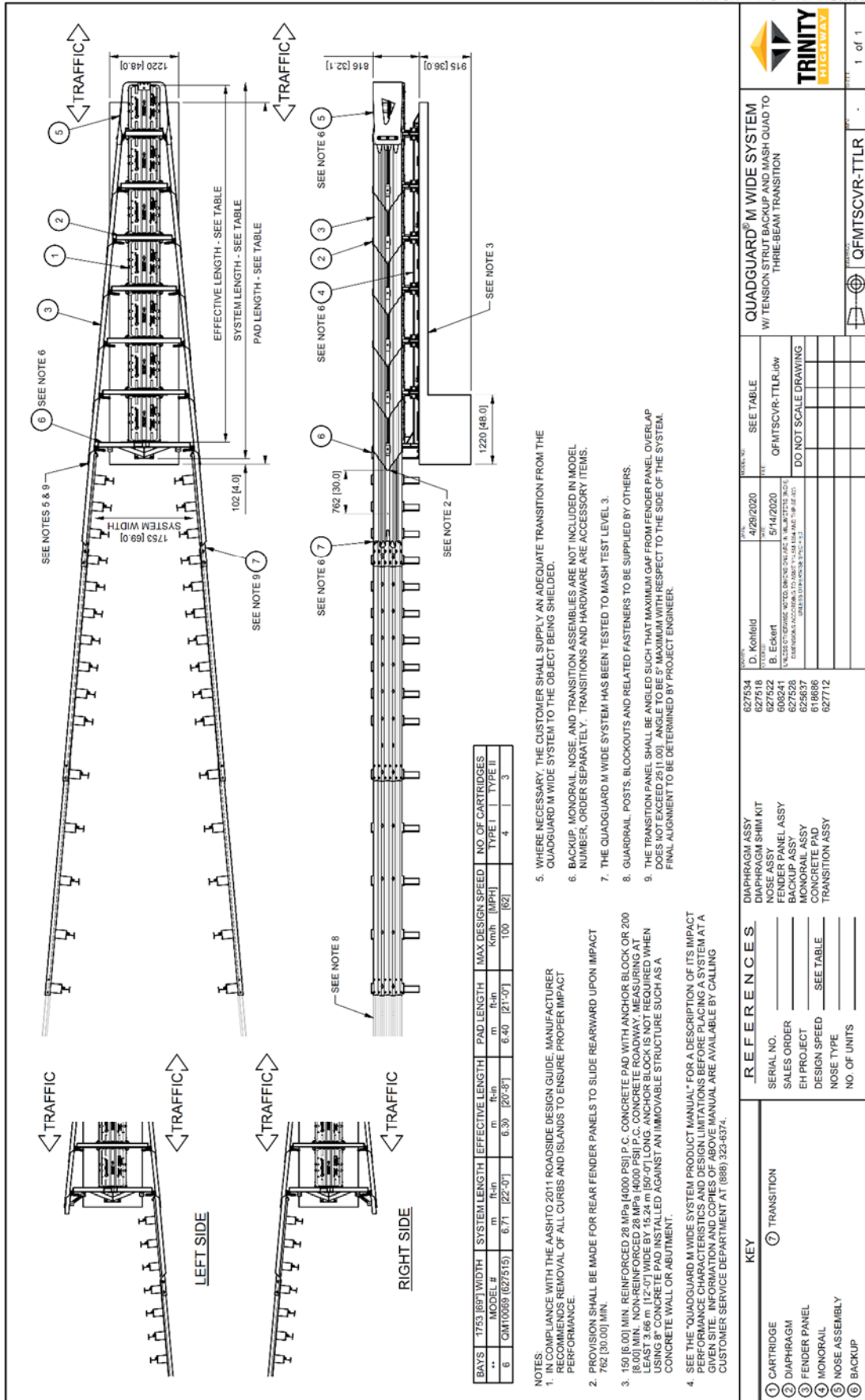

**TRINITY HIGHWAY**

**QUADGUARD® M WIDE SYSTEM**  
W/ TENSION STRUT BACKUP AND MASH QUAD TO THRIE-BEAM TRANSITION

DO NOT SCALE DRAWING

QFMTSCVR-TTLR.dwg

4/29/2020

5/14/2020

627534

627518

627522

627528

626537

627712

D. Kohfeld

B. Eckert

627534

627518

627522

627528

626537

627712

QFMTSCVR-TTLR

1 of 1

**Thrie-Beam Transition QFMTSCVR-TTLR**

KEY	REFERENCES
① CARTRIDGE	DIAPHRAGM ASSY
② DIAPHRAGM	DIAPHRAGM SHIM KIT
③ FENDER PANEL	NOSE ASSEMBLY
④ MONORAIL	NOSE ASSEMBLY
⑤ NOSE ASSEMBLY	MONORAIL ASSY
⑥ BACKUP	CONCRETE PAD
	TRANSITION ASSY
	NOSE TYPE
	NO. OF UNITS
	NO. OF CARTRIDGES
	TYPE I
	TYPE II



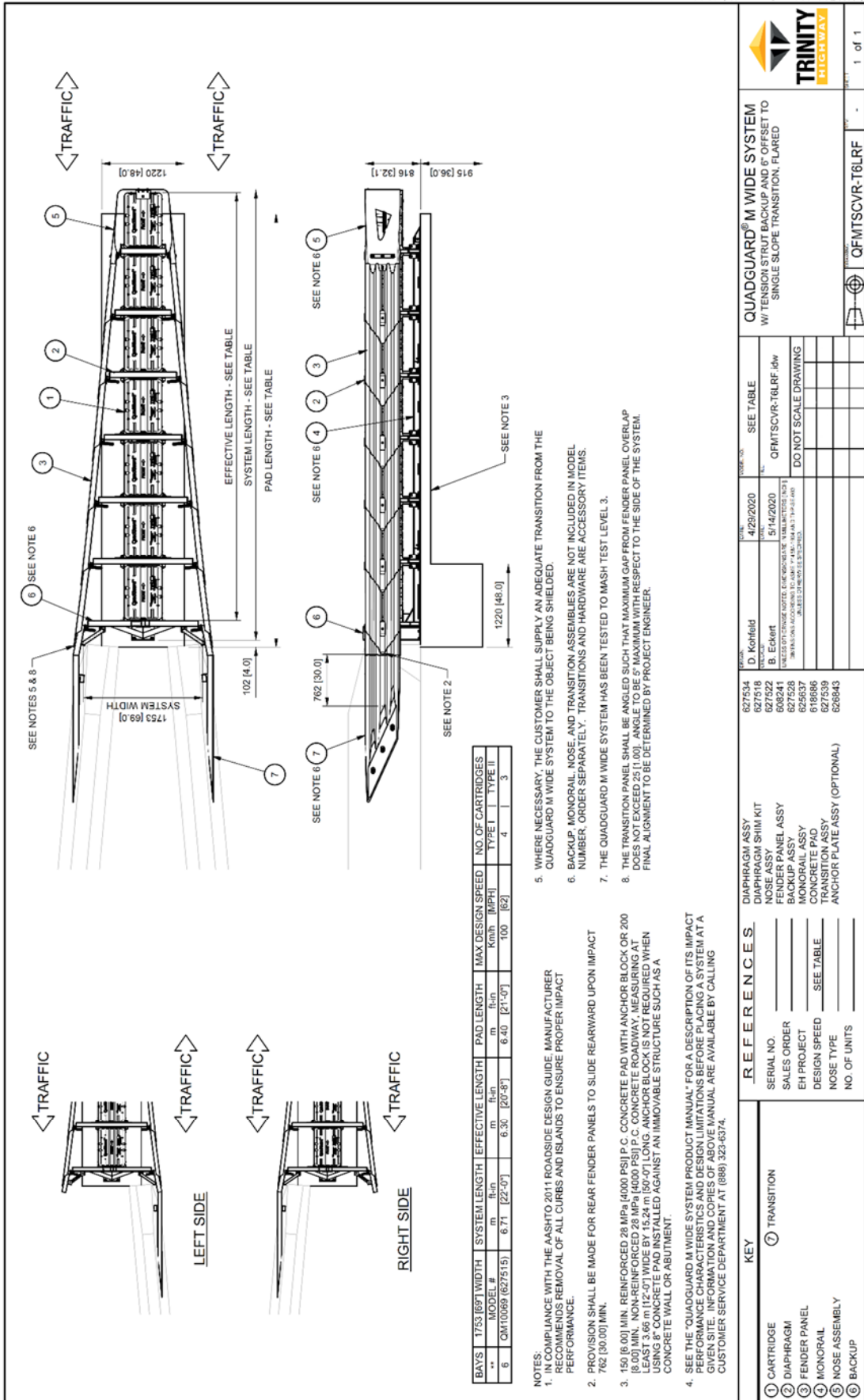

Single Slope Transition QFMTCVVR-T6LRF

**TRINITY HIGHWAY**

QUADGUARD® M WIDE SYSTEM  
W/ TENSION STRUT BACKUP AND 6" OFFSET TO  
SINGLE SLOPE TRANSITION, FLARED

DATE: 4/29/2020  
DRAWN BY: B. Eckert  
CHECKED BY: D. Kohfeld  
SCALE: 1:1

PROJECT: QFMTCVVR-T6LRF idw  
SHEET: 1 of 1



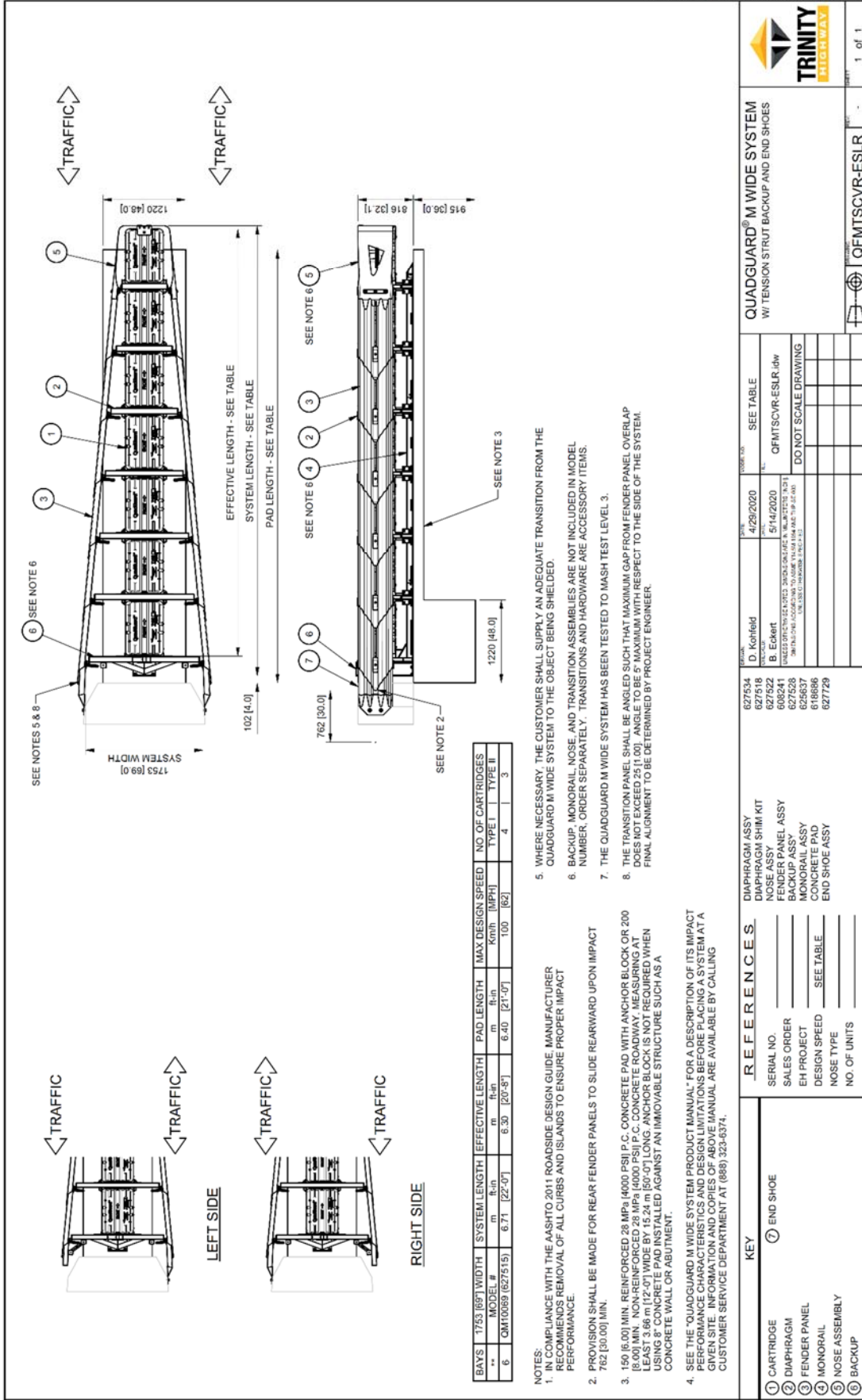

		<b>QUADGUARD® M WIDE SYSTEM</b> W/ TENSION STRUT BACKUP AND END SHOES	
SERIAL NO. SALES ORDER EH PROJECT DESIGN SPEED NOSE TYPE NO. OF UNITS	SERIAL NO. SALES ORDER EH PROJECT DESIGN SPEED NOSE TYPE NO. OF UNITS	DATE 4/29/2020	DATE 5/14/2020
D:\PHR\BGM ASSY DIAPHRAGM SHIM KIT NOSE ASSY FENDER PANEL ASSY BACKUP ASSY MONORAIL ASSY CONCRETE PAD END SHOE ASSY		D. Kohfeld B. Eckert	QFMTSCVR-ESLR.dwg DO NOT SCALE DRAWING
KEY ① CARTRIDGE ② DIAPHRAGM ③ FENDER PANEL ④ MONORAIL ⑤ NOSE ASSEMBLY ⑥ BACKUP		QFMTSCVR-ESLR	

Vertical Barrier Transition QFMTSCVR-ESLR

**NOTES:**

**NOTES:**



# TRINITY

## HIGHWAY

*Ahead of the Curve*<sup>®</sup>

For more complete information on Trinity Highway products and services, visit us on the web at [www.trinityhighway.com](http://www.trinityhighway.com). Materials and specifications are subject to change without notice. Please contact Trinity Highway to confirm that you are referring to the most current instructions.

[www.trinityhighway.com](http://www.trinityhighway.com)

888.323.6374 (USA)

+1 214.589.8140 (International)