





















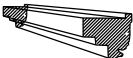

















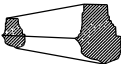



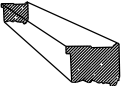

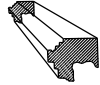

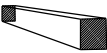

















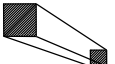

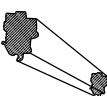







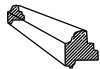

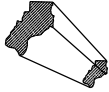











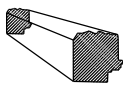

ADAMS 	ALLEN 	BARTHO 	BENTON 
BLACK 	BOONE 	BROWN 	CARROL 
CASS 	CLARK 	CLAY 	CLINTON 
CRAWFORD 	DAVIES 	DEARBORN 	DECATUR 
DEKALB 	DELAWARE 	DUBOIS 	ELKHART 
FAYETTE 	FLOYD 	FOUNTAIN 	FRANKLIN 
FULTON 	GIBSON 	GRANT 	GREENE 
HAMILTON 	HANCOCK 	HARRIS 	HENDRICK 

HENRY 	HOWARD 	HUNTING 	JACKSON 
JASPER 	JAY 	JEFFERS 	JENNING 
JOHNSON 	KNOX 	KOSCIUS 	LAGRANGE 
LAKE 	LAPORTE 	LAWRENCE 	MADISON 
MARION 	MARSHA 	MARTIN 	MIAMI 
MONROE 	MONTGOM 	MORGAN 	NEWTON 
NOBLE 	OHIO 	ORANGE 	OWEN 
PARKE 	PERRY 	PIKE 	PORTER 

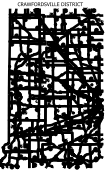
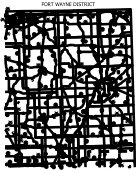
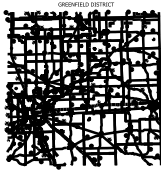
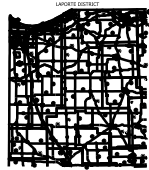

<p>POSEY</p> 	<p>PULASKI</p> 	<p>PUTNAM</p> 	<p>RANDOLPH</p> 
<p>RIPLEY</p> 	<p>RUSH</p> 	<p>SCOTT</p> 	<p>SHELBY</p> 
<p>SPENCE</p> 	<p>STARKE</p> 	<p>STEUBEN</p> 	<p>STJOSEPH</p> 
<p>SULLIVAN</p> 	<p>SWITZ</p> 	<p>TIPPECA</p> 	<p>TIPTON</p> 
<p>UNION</p> 	<p>VANDERB</p> 	<p>VERMILL</p> 	<p>VIGO</p> 
<p>WABASH</p> 	<p>WARREN</p> 	<p>WARRICK</p> 	<p>WASHING</p> 
<p>WAYNE</p> 	<p>WELLS</p> 	<p>WHITE</p> 	<p>WHITLEY</p> 
<p>SN_CRAWFORDSVILLE</p> 	<p>SN_FORT WAYNE</p> 	<p>SN_GREENFIELD</p> 	<p>SN_LAPORTE</p> 

<p>SN_SEYMOUR</p> <p><small>SEYMOUR DISTRICT</small></p> 	<p>SN_VINCENNES</p> <p><small>VINCENNES DISTRICT</small></p> 	<p>DS_PROLOC_E</p> 	

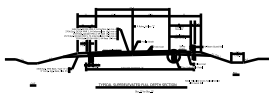
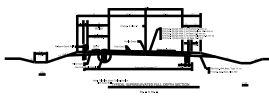
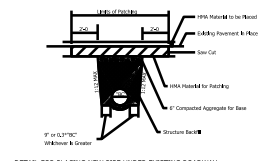
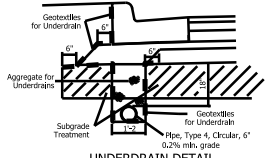
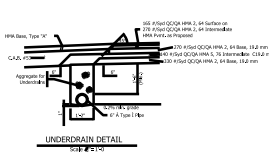
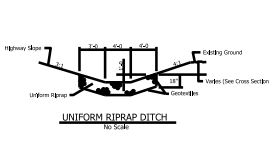
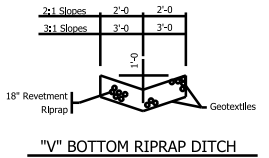

<p>BR_DEKEND</p> <p>Deck Reinforcement Scale: 1/4" = 1'-0"</p>	<p>BR_ENDBNT</p> <p>Mudwall Reconstruction - Beams 1 & 4 Scale: 1/4" = 1'-0"</p>	<p>BR_RAILAN</p> <p>Scale: 1/4" = 1'-0"</p>	<p>BR_REMOV</p> <p>Scale: 1/4" = 1'-0"</p>												
<p>BR_SHLDR</p> <p>HMA Wedge Existing Pavement Existing Shoulder Typical Section w/ Guardrail (NTS)</p>	<p>BR_WEDGE</p> <p>Scale: 1/4" = 1'-0"</p>	<p>BR_ELEV</p> <p>ELEVATION</p> <table border="1"> <thead> <tr> <th></th> <th>SPAN A OR C</th> <th>SPAN B</th> </tr> </thead> <tbody> <tr> <td>Unshaded Beam Center</td> <td>2222</td> <td>2222</td> </tr> <tr> <td>Shaded Beam Center</td> <td>2222</td> <td>2222</td> </tr> <tr> <td>Shaded Beam Center</td> <td>2222</td> <td>2222</td> </tr> </tbody> </table>		SPAN A OR C	SPAN B	Unshaded Beam Center	2222	2222	Shaded Beam Center	2222	2222	Shaded Beam Center	2222	2222	<p>BR_SECAA</p> <p>SECTION A-A</p> <p>Beige seat elevations were calculated using radial beam center (ridge center and deck face reflection of slab) with the top of beam 1/4" below the bottom of slab elevation at the center of spans.</p>
	SPAN A OR C	SPAN B													
Unshaded Beam Center	2222	2222													
Shaded Beam Center	2222	2222													
Shaded Beam Center	2222	2222													
<p>DIST_GRAILCAS_E</p> <p>GUARDRAIL CONNECTOR 44</p>	<p>EA_TYP2L</p>	<p>EA_TYP3LB</p>	<p>EA_TYP3LS</p>												
<p>DS_ANCHORPLATE_E</p> <p>Anchor Plate MK-AP1 Scale: 1/4" = 1'-0"</p>	<p>DS_B4CB12_E</p> <p>SECTION CB-12 Scale: 1/4" = 1'-0"</p>	<p>DS_B4CB17_E</p> <p>SECTION CB-17 Scale: 1/4" = 1'-0"</p>	<p>DS_B4CB21_E</p> <p>SECTION CB-21 Scale: 1/4" = 1'-0"</p>												
<p>DS_B4CB27_E</p> <p>SECTION CB-27 Scale: 1/4" = 1'-0"</p>	<p>DS_B4CB33_E</p> <p>SECTION CB-33 Scale: 1/4" = 1'-0"</p>	<p>DS_B4CB42_E</p> <p>SECTION CB-42 Scale: 1/4" = 1'-0"</p>	<p>DS_BAR591_E</p> <p>591a x 5'-6"</p>												
<p>DS_BAR594_E</p> <p>594 x 3'-0"</p>	<p>DS_BNDET_E</p> <p>BEAM NOTCH DETAILS</p>	<p>DS_BRNGASEM_E</p>	<p>DS_BRRAIL_E</p>												
<p>DS_BXCB12_E</p> <p>SECTION CB-12 Scale: 1/4" = 1'-0"</p>	<p>DS_BXCB17_E</p> <p>SECTION CB-17 Scale: 1/4" = 1'-0"</p>	<p>DS_BXCB21_E</p> <p>SECTION CB-21 Scale: 1/4" = 1'-0"</p>	<p>DS_BXCB27_E</p> <p>SECTION CB-27 Scale: 1/4" = 1'-0"</p>												
<p>DS_BXCB33_E</p> <p>SECTION CB-33 Scale: 1/4" = 1'-0"</p>	<p>DS_BXCB42_E</p> <p>SECTION CB-42 Scale: 1/4" = 1'-0"</p>	<p>DS_CONSECIN_E</p> <p>SECTION T-1"</p>	<p>DS_CONSECOUT_E</p> <p>SECTION T-1"</p>												

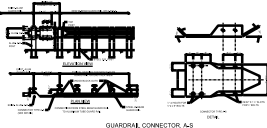

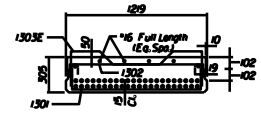
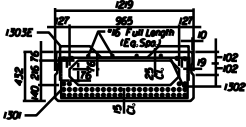
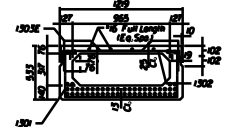
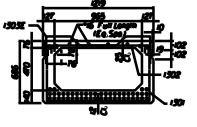
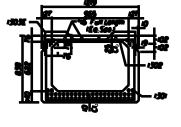
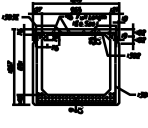
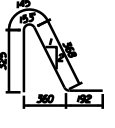
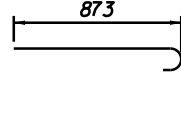
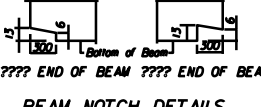
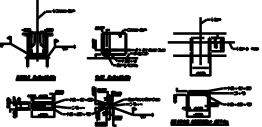
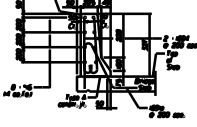
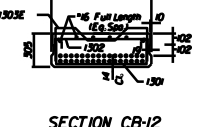
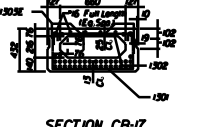
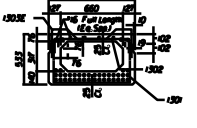
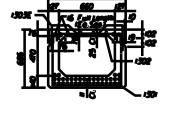
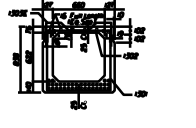
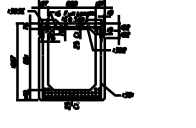
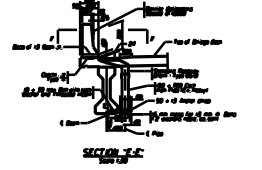
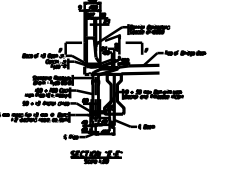
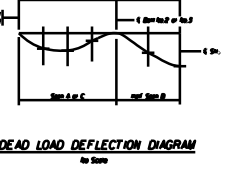
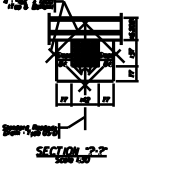
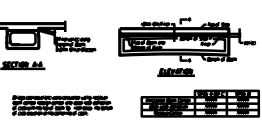
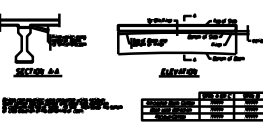
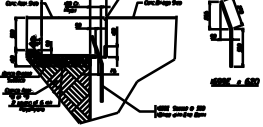
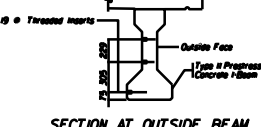
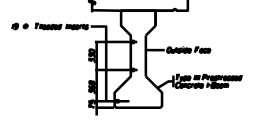
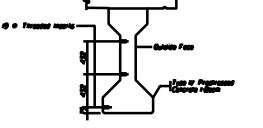
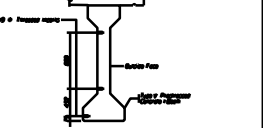
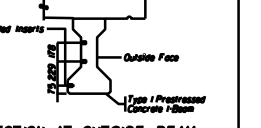

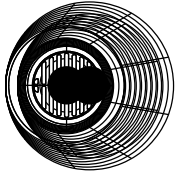
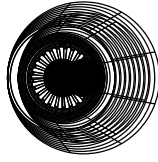
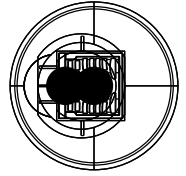
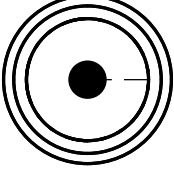
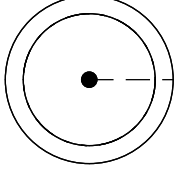
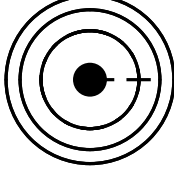

<p>DS_DLDEF_E</p> <p>DEAD LOAD DEFLECTION DIAGRAM No Scale</p>	<p>DS_DRAIN1_E</p> <p>SECTION "F-F"</p>	<p>DS_FILET2_E</p> <p>SECTION AA ELEVATION</p>	<p>DS_FILLET_E</p> <p>SECTION AA ELEVATION</p>
<p>DS_PVMTLDGE_E</p> <p>PAVEMENT LEDGE DETAIL No Scale</p>	<p>DS_SECOB2_E</p> <p>SECTION AT OUTSIDE BEAM Scale: 1/2" = 1'-0"</p>	<p>DS_SECOB3_E</p> <p>SECTION AT OUTSIDE BEAM Scale: 1/2" = 1'-0"</p>	<p>DS_SECOB4_E</p> <p>SECTION AT OUTSIDE BEAM Scale: 1/2" = 1'-0"</p>
<p>DS_SECOB5_E</p> <p>SECTION AT OUTSIDE BEAM Scale: 1/2" = 1'-0"</p>	<p>DS_SECOB_E</p> <p>SECTION AT OUTSIDE BEAM Scale: 1/2" = 1'-0"</p>	<p>DS_SECSR2_E</p> <p>SECTION SHOWING REINFORCING Scale: 1/2" = 1'-0"</p>	<p>DS_SECSR3_E</p> <p>SECTION SHOWING REINFORCING Scale: 1/2" = 1'-0"</p>
<p>DS_SECSR4_E</p> <p>SECTION SHOWING REINFORCING Scale: 1/2" = 1'-0"</p>	<p>DS_SECSR_E</p> <p>SECTION SHOWING REINFORCING Scale: 1/2" = 1'-0"</p>	<p>DS_TYPSS2_E</p> <p>TYPICAL SECTION SPAN Scale: 1/2" = 1'-0"</p>	<p>DS_TYPSS3_E</p> <p>TYPICAL SECTION SPAN Scale: 1/2" = 1'-0"</p>
<p>DS_TYPSS4_E</p> <p>TYPICAL SECTION SPAN Scale: 1/2" = 1'-0"</p>	<p>DS_TYPSS_E</p> <p>TYPICAL SECTION SPAN Scale: 1/2" = 1'-0"</p>	<p>DS_BWEDGE_E</p> <p>BITUMINOUS WEDGE DETAIL No Scale</p>	<p>DS_DRIO20_E</p> <p>SODDED DITCH No Scale</p>
<p>DS_DRIO30_E</p> <p>SODDED DITCH No Scale</p>	<p>DS_GR_E</p> <p>TYPICAL SECTION WITH GUARD RAIL No Scale</p>	<p>DS_GRETD_E</p> <p>GUARD RAIL END TREATMENT DETAIL No Scale</p>	<p>DS_INCID_E</p> <p>NORMAL INFILTRATION SECTION No Scale</p>
<p>DS_PRJD_E</p> <p>PAVEMENT RELIEF JOINT DETAIL No Scale</p>	<p>DS_PVMTW_E</p> <p>TYPICAL PAVEMENT REINFORCING DETAIL No Scale</p>	<p>DS_PZ1000_E</p> <p>ROADWAY AND SHOULDER LAYOUT No Scale</p>	<p>DS_RRAPD_E</p> <p>RIPRAP DETAIL No Scale</p>
<p>DS_RT1000_E</p> <p>RIPRAP TURNOUT TYPICAL SECTION No Scale</p>	<p>DS_RUNAR_E</p> <p>TYPICAL CROSS SECTION TEMPORARY REINFORCED No Scale</p>	<p>DS_RWSLAY_E</p> <p>ROADWAY AND SHOULDER LAYOUT No Scale</p>	<p>DS_SPI000_E</p> <p>STEEL SETTLEMENT SLATE No Scale</p>

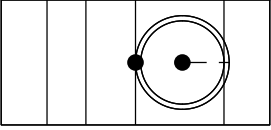
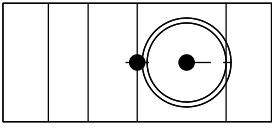
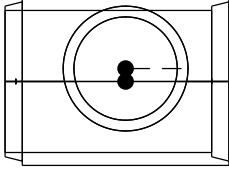
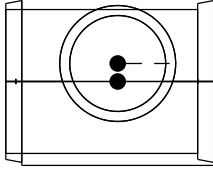
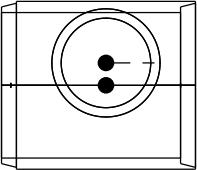
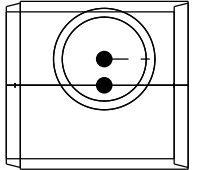
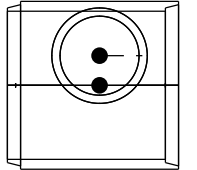
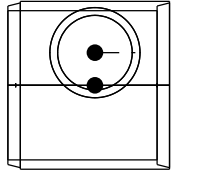
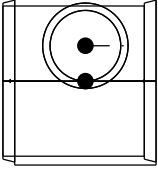
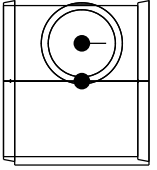
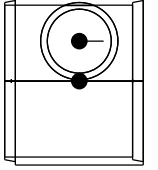
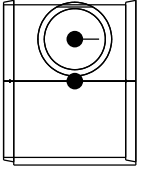
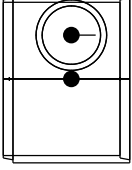
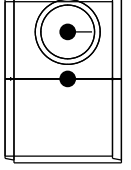
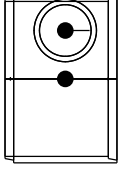
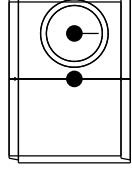
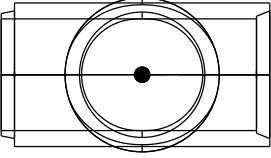
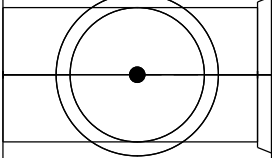
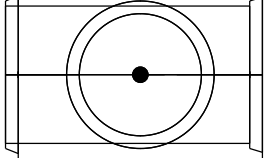
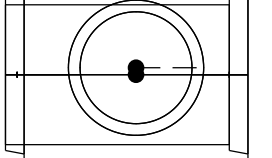
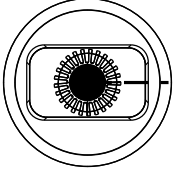
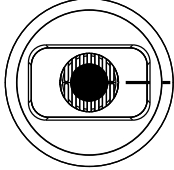
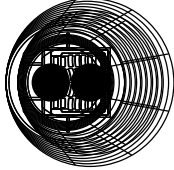
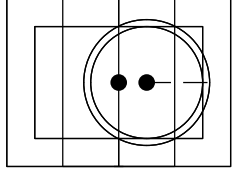
<p><i>DS_TSI010_E</i></p> 	<p><i>DS_TSI020_E</i></p> 	<p><i>DS_TSI030_E</i></p> 	<p><i>DS_TSI100_E</i></p>  <p>DETAIL FOR PLACING NEW PIPE UNDER EXISTING ROADWAY</p>
<p><i>DS_UDI020_E</i></p>  <p>UNDERDRAIN DETAIL</p>	<p><i>DS_UDRAIN_E</i></p>  <p>UNDERDRAIN DETAIL</p>	<p><i>DS_URRD_E</i></p>  <p>UNIFORM RIPRAP DITCH No Scale</p>	<p><i>DS_VBRAPD_E</i></p>  <p>"V" BOTTOM RIPRAP DITCH No Scale</p>
<p><i>TR_Temp conc barrier from</i> <i>TR_Temp concrete barrier top</i> <i>TR_Temp concrete barrier top</i></p>			
Empty cell			
Empty cell			
Empty cell			
Empty cell			
Empty cell			
Empty cell			
Empty cell			

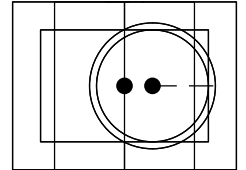
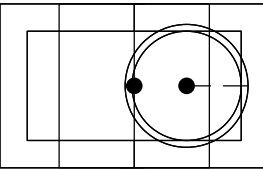
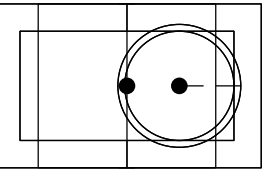
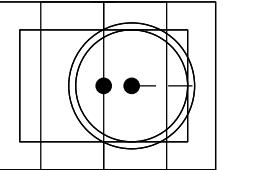
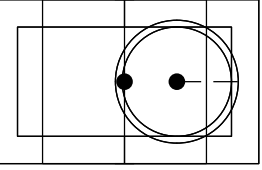
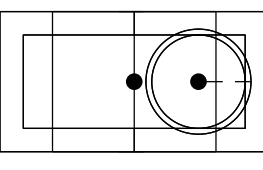
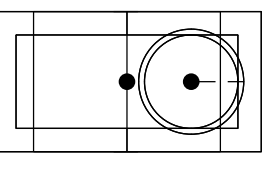
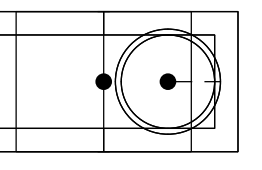
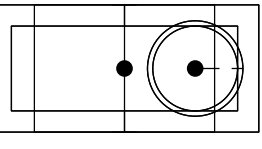
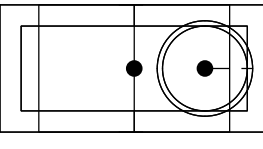
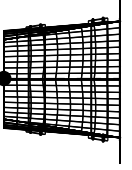
<p>Default</p>	<p>DIST_GRAILCAS_M</p> 	<p>DS_ANCHORPLATE_M</p> 	<p>DS_B4CB12_M</p> 
<p>DS_B4CB17_M</p> 	<p>DS_B4CB21_M</p> 	<p>DS_B4CB27_M</p> 	<p>DS_B4CB33_M</p> 
<p>DS_B4CB42_M</p> 	<p>DS_BAR 1691_M</p> 	<p>DS_BAR 1694_M</p> 	<p>DS_BNDET_M</p> 
<p>DS_BRNGASEM_M</p> 	<p>DS_BRRAIL_M</p> 	<p>DS_BXCB12_M</p> 	<p>DS_BXCB17_M</p> 
<p>DS_BXCB21_M</p> 	<p>DS_BXCB27_M</p> 	<p>DS_BXCB33_M</p> 	<p>DS_BXCB42_M</p> 
<p>DS_CONSECIN_M</p> 	<p>DS_CONSECOUT_M</p> 	<p>DS_DLDEF_M</p> 	<p>DS_DRAIN1_M</p> 
<p>DS_FILET2_M</p> 	<p>DS_FILLET_M</p> 	<p>DS_PVMTLDGE_M</p> 	<p>DS_SECOB2_M</p> 
<p>DS_SECOB3_M</p> 	<p>DS_SECOB4_M</p> 	<p>DS_SECOB5_M</p> 	<p>DS_SECOB_M</p> 

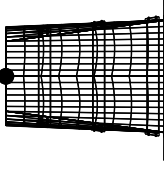
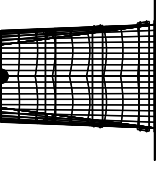
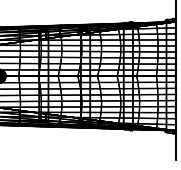
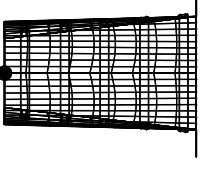
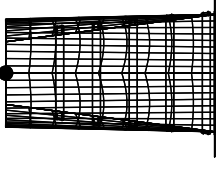
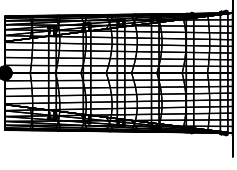
<p>DS_SECSR2_M</p> <p>SECTION SHOWING REINFORCING Scale 1:20</p>	<p>DS_SECSR3_M</p> <p>SECTION SHOWING REINFORCING Scale 1:20</p>	<p>DS_SECSR4_M</p> <p>SECTION SHOWING REINFORCING Scale 1:20</p>	<p>DS_SECSR_M</p> <p>SECTION SHOWING REINFORCING Scale 1:20</p>														
<p>DS_TYPSS2_M</p> <p>TYPICAL SECTION SPAN Scale 1:20</p>	<p>DS_TYPSS3_M</p> <p>TYPICAL SECTION SPAN Scale 1:20</p>	<p>DS_TYPSS4_M</p> <p>TYPICAL SECTION SPAN Scale 1:20</p>	<p>DS_TYPSS_M</p> <p>TYPICAL SECTION SPAN Scale 1:20</p>														
<p>DS_BWEDGE_M</p> <p>BITUMINOUS WEDGE DETAIL No Scale</p>	<p>DS_DR1020_M</p> <table border="1"> <tr> <td>2:1 Slopes</td> <td>0.6</td> <td>1.2</td> <td>0.6</td> </tr> <tr> <td>3:1 Slopes</td> <td>0.9</td> <td>1.2</td> <td>0.9</td> </tr> </table> <p>SODDED DITCH No Scale</p>	2:1 Slopes	0.6	1.2	0.6	3:1 Slopes	0.9	1.2	0.9	<p>DS_DR1030_M</p> <table border="1"> <tr> <td>2:1 Slopes</td> <td>0.8</td> <td>0.6</td> </tr> <tr> <td>3:1 Slopes</td> <td>0.9</td> <td>0.9</td> </tr> </table> <p>"V" BOTTOM SODDED DITCH No Scale</p>	2:1 Slopes	0.8	0.6	3:1 Slopes	0.9	0.9	<p>DS_FULL_M</p> <p>Full Curb</p>
2:1 Slopes	0.6	1.2	0.6														
3:1 Slopes	0.9	1.2	0.9														
2:1 Slopes	0.8	0.6															
3:1 Slopes	0.9	0.9															
<p>DS_GR_M</p> <p>TYPICAL SECTION WITH GUARD RAIL</p>	<p>DS_GRETD_M</p> <p>Guard Rail End Treatment</p>	<p>DS_INCID_M</p> <p>INCIDENT CURB SECTION Scale 1:20</p>	<p>DS_PRJD_M</p> <p>PAVEMENT RELIEF JOINT DETAIL No Scale</p>														
<p>DS_PVMTW_M</p> <p>TYPICAL PAVEMENT WIDENING SECTION Scale 1:20</p>	<p>DS_PZ1000_M</p> <p>Post-and-Rail Curb</p>	<p>DS_RRAPD_M</p> <table border="1"> <tr> <td>2:1 Slopes</td> <td>600</td> <td>600</td> <td>600</td> </tr> <tr> <td>3:1 Slopes</td> <td>900</td> <td>900</td> <td>900</td> </tr> </table> <p>RIPRAP DITCH No Scale</p>	2:1 Slopes	600	600	600	3:1 Slopes	900	900	900	<p>DS_RT1000_M</p> <p>RIPRAP TURNOUT TYPICAL SECTION No Scale</p>						
2:1 Slopes	600	600	600														
3:1 Slopes	900	900	900														
<p>DS_RUNAR_M</p> <p>TYPICAL CROSS-SECTION RUN-OFF CURB Scale 1:20</p>	<p>DS_RWSLAY_M</p> <p>ROADWAY AND SHOULDER LAYOUT</p>	<p>DS_SPI000_M</p> <p>STEEL SETTLEMENT PLATE</p>	<p>DS_TSIO10_M</p> <p>Curb Cross-Section</p>														
<p>DS_TSIO20_M</p> <p>Curb Cross-Section</p>	<p>DS_TSIO30_M</p> <p>Curb Cross-Section</p>	<p>DS_TS1100_M</p> <p>Curb Cross-Section with Reinforcement</p>	<p>DS_UDIO20_M</p> <p>UNDERDRAIN DETAIL</p>														
<p>DS_UDRAIN_M</p> <p>UNDERDRAIN DETAIL Scale 1:20</p>	<p>DS_URRD_M</p> <p>UNIFORM RIPRAP DITCH No Scale</p>	<p>DS_VBRAPD_M</p> <table border="1"> <tr> <td>2:1 Slopes</td> <td>600</td> <td>600</td> </tr> <tr> <td>3:1 Slopes</td> <td>900</td> <td>900</td> </tr> </table> <p>"V" BOTTOM RIPRAP DITCH No Scale</p>	2:1 Slopes	600	600	3:1 Slopes	900	900	<p>DS_UDRAIN_M</p> <p>UNDERDRAIN DETAIL</p>								
2:1 Slopes	600	600															
3:1 Slopes	900	900															

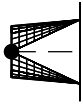
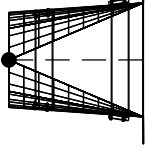
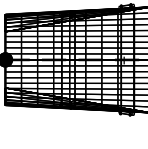
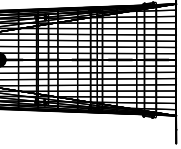
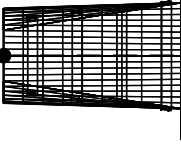
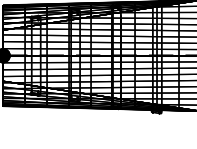
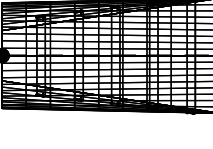

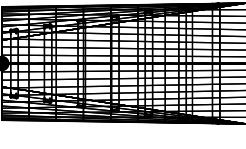
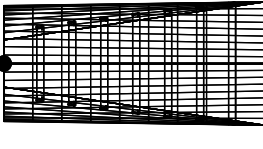
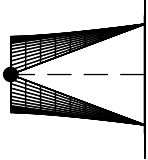
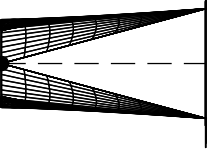
Default	Top - Inlet Cover G 	Top - Inlet Cover E 	Top - Inlet Flat Cover C 
Bottom - Catch Basin 4 Dia 	Bottom - Leaching Basin 4 Dia 	Bottom - Catch Basin 2 Dia 	Top - Manhole Cover B 
Bottom - MB Type 1 - 102 Dia 	Bottom - MB Type 1 - 108 Dia 	Bottom - PMT 66 Dia 	Bottom - PMT 72 Dia 
Bottom - PMT 78 Dia 	Bottom - PMT 84 Dia 	Bottom - PMT 90 Dia 	Bottom - PMT 96 Dia 
Bottom - PMT 102 Dia 	Bottom - PMT 108 Dia 	Bottom - PMT 114 Dia 	Bottom - PMT 120 Dia 
Bottom - PMT 126 Dia 	Bottom - PMT 138 Dia 	Bottom - PMT 144 Dia 	Bottom - PMT 132 Dia 
Bottom - PMT 42 Dia 	Bottom - PMT 48 Dia 	Bottom - PMT 54 Dia 	Bottom - PMT 60 Dia 
Top - Inlet Flat Cover E 	Top - Inlet Flat Cover G 	Top - Inlet Cover C 	Bottom - MB Type 2 - 48 Dia 

<p>Bottom - MB Type 2 - 60 Dia</p> 	<p>Bottom - MB Type 2 - 66 Dia</p> 	<p>Bottom - MB Type 2 - 78 Dia</p> 	<p>Bottom - MB Type 2 - 54 Dia</p> 
<p>Bottom - MB Type 2 - 72 Dia</p> 	<p>Bottom - MB Type 2 - 84 Dia</p> 	<p>Bottom - MB Type 2 - 96 Dia</p> 	<p>Bottom - MB Type 2 - 90 Dia</p> 
<p>Bottom - MB Type 2 - 102 Dia</p> 	<p>Bottom - MB Type 2 - 108 Dia</p> 	<p>Headwall - Sloped ES - 19 X 34</p> 	<p>Headwall - Sloped ES - 22 X 34</p> 
<p>Headwall - Sloped ES - 24 X 34</p> 	<p>Headwall - Sloped ES - 27 X 34</p> 	<p>Headwall - Sloped ES - 29 X 34</p> 	<p>Headwall - Sloped ES - 34 X 53</p> 
<p>Headwall - Sloped ES - 38 X 60</p> 	<p>Headwall - Sloped ES - 43 X 60</p> 	<p>Headwall - Sloped ES - 48 X 60</p> 	<p>Headwall - Sloped ES - 21 X 15</p> 
<p>Headwall - Sloped ES - 24 X 29</p> 	<p>Headwall - Sloped ES - 28 X 29</p> 	<p>Headwall - Sloped ES - 35 X 29</p> 	<p>Headwall - Sloped ES - 42 X 29</p> 
<p>Headwall - Sloped ES - 49 X 47</p> 	<p>Headwall - Sloped ES - 57 X 47</p> 	<p>Headwall - Sloped ES - 64 X 47</p> 	<p>Headwall - Sloped ES - 71 X 47</p> 
<p>Headwall - Sloped ES - 77 X 57</p> 	<p>Headwall - Sloped ES - 83 X 57</p> 	<p>Headwall - Sloped ES - 18 Dia</p> 	<p>Headwall - Sloped ES - 24 Dia</p> 

	Headwall - Sloped ES - 30 Dia Steel Sloped ES - 42 Dia Steel Sloped ES - 54 Dia Steel Sloped ES - 36 Dia Steel				
	Headwall - Sloped ES - 21 Dia Steel Sloped ES - 15 Dia Steel Sloped ES - 27 Dia Steel Sloped ES - 48 Dia Steel				
4 Steel 4-1	Headwall - Sloped ES - 60 Dia Steel Head Flat Cover			Headwall - 6 Dia Outlet	Headwall - 8 Dia Outlet
3 Steel 4-1	Headwall - 10 Dia Outlet	Headwall - 12 Dia Outlet	Headwall - 15 Dia Outlet	Headwall - 18 Dia Outlet	
Steel 4-1	Headwall - 24 Dia Outlet	Headwall - 30 Dia Outlet	Headwall - 36 Dia Outlet	Headwall - FES - 12 Dia Steel	
Metal 4-1	Headwall - FES - 15 Dia Steel	Headwall - FES - 17 x 13 Steel	Headwall - FES - 18 Dia Steel	Headwall - FES - 21 Dia Steel	
Steel 4-1	Headwall - FES - 21 x 15 Steel	Headwall - FES - 24 Dia Steel	Headwall - FES - 24 x 18 Steel	Headwall - FES - 28 x 20 Steel	
Steel 4-1	Headwall - FES - 30 Dia Steel	Headwall - FES - 35 x 24 Steel	Headwall - FES - 36 Dia Steel	Headwall - FES - 42 Dia Steel	

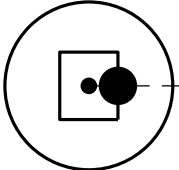
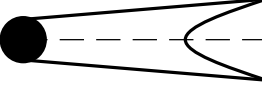
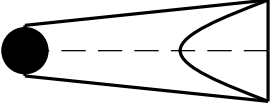
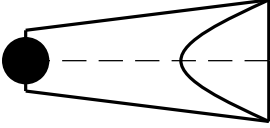
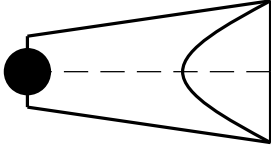
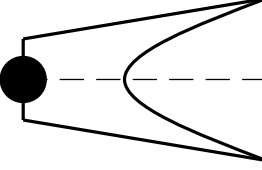
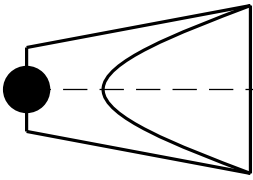
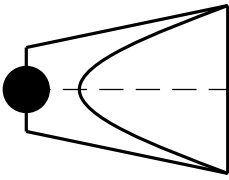
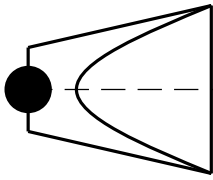
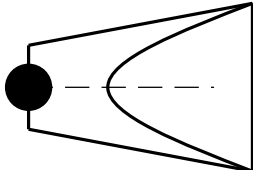
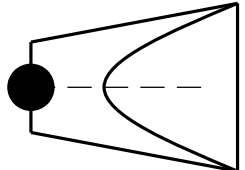
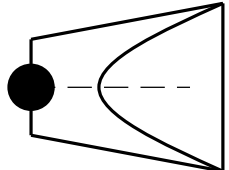
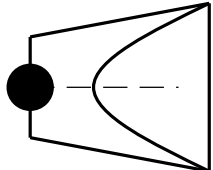
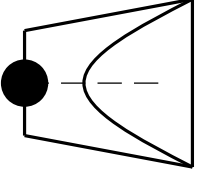
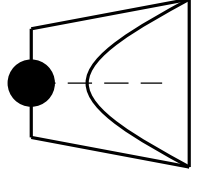
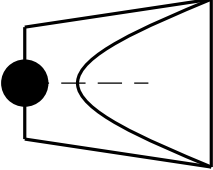
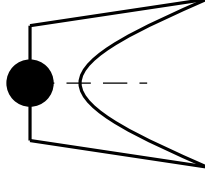
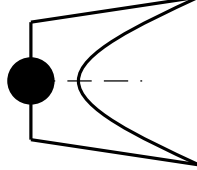
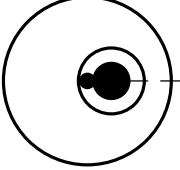
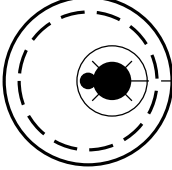
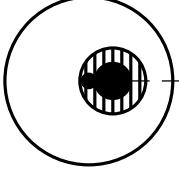
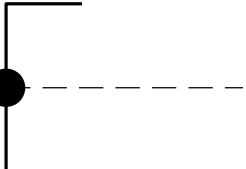
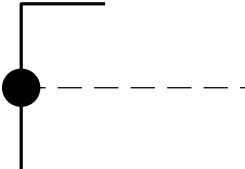
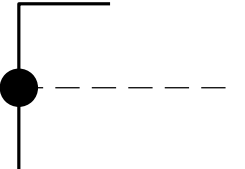
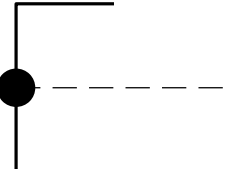
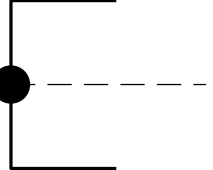
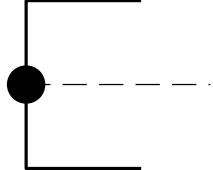
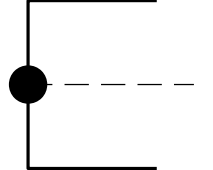
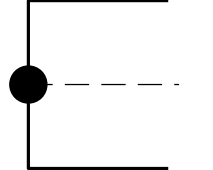

Cell Library: IN_Drainage Features.cel

Steel 4-l	Headwall - FES - 42 x 29 Dia 	Headwall - FES - 48 Dia 	Headwall - FES - 49 x 33 Dia 	Headwall - FES - 54 Dia 	Steel
Steel 4-l	Headwall - FES - 57 x 38 Dia 	Headwall - FES - 60 Dia 	Headwall - FES - 64 x 43 Dia 	Headwall - FES - 66 Dia 	Steel
	Headwall - FES - 71 x 47 Dia 	Headwall - FES - 72 Dia 	Headwall - FES - 77 x 52 Dia 	Headwall - FES - 78 Dia 	Steel
	Headwall - FES - 83 x 57 Dia 	Headwall - FES - 84 Dia 	Headwall - Sloped ES - 15 Dia 	Headwall - Sloped ES - 18 Dia 	Steel
	Headwall - Sloped ES - 24 Dia 	Headwall - Sloped ES - 30 Dia 	Headwall - Sloped ES - 36 Dia 	Headwall - FES - 14 X 23 	Steel
	Headwall - FES - 12 Dia 	Headwall - FES - 15 Dia 	Headwall - FES - 18 Dia 	Headwall - FES - 21 Dia 	Precast
	Headwall - FES - 24 Dia 	Headwall - FES - 27 Dia 	Headwall - FES - 30 Dia 	Headwall - FES - 36 Dia 	Precast
	Headwall - FES - 42 Dia 	Headwall - FES - 48 Dia 	Headwall - FES - 60 Dia 	Headwall - FES - 66 Dia 	Precast

Headwall - FES - 72 Dia Precast 	Headwall - FES - 78 Dia Precast 	Headwall - FES - 84 Dia Precast 	Precast Inlet C 
Plan - FES - 12 Precast 	Plan - FES - 15 Precast 	Plan - FES - 18 Precast 	Plan - FES - 21 Precast 
Plan - FES - 24 Precast 	Plan - FES - 27 Precast 	Plan - FES - 30 Precast 	Plan - FES - 33 Precast 
Plan - FES - 36 Precast 	Plan - FES - 42 Precast 	Plan - FES - 48 Precast 	Plan - FES - 54 Precast 
Plan - FES - 60 Precast 	Plan - FES - 66 Precast 	Plan - FES - 72 Precast 	Plan - FES - 78 Precast 
Plan - FES - 84 Precast 	Plan - Manhole B 	Plan - Inlet E 	Plan - Inlet G 
Plan - Headwall - 6 Dia Outlet 	Plan - Headwall - 8 Dia Outlet 	Plan - Headwall - 10 Dia Outlet 	Plan - Headwall - 12 Dia Outlet 
Plan - Headwall - 15 Dia Outlet 	Plan - Headwall - 18 Dia Outlet 	Plan - Headwall - 24 Dia Outlet 	Plan - Headwall - 30 Dia Outlet 



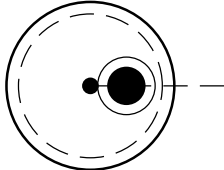
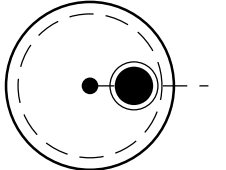
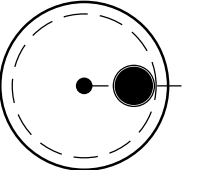
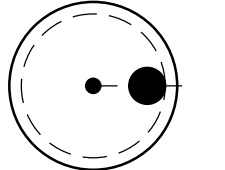
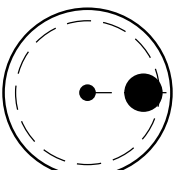
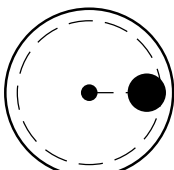
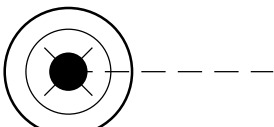
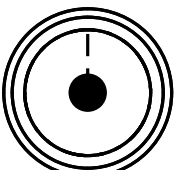
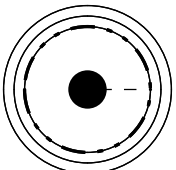
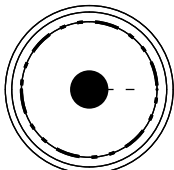
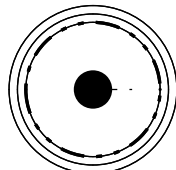
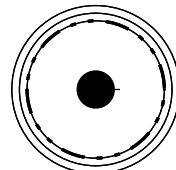
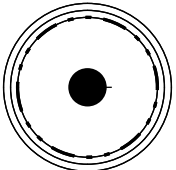

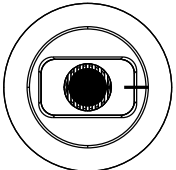
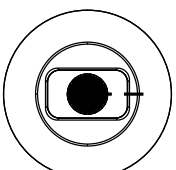
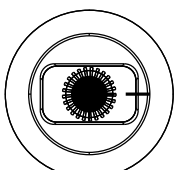
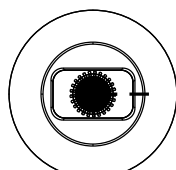
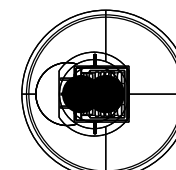
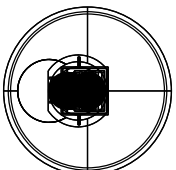
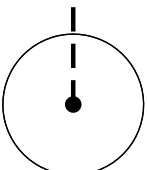
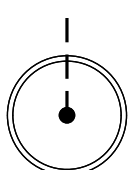
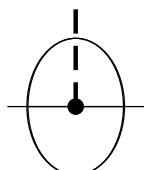
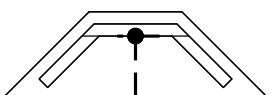
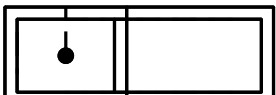
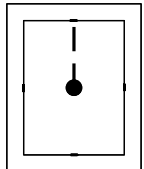
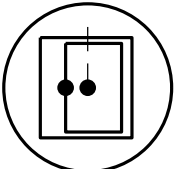
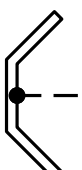
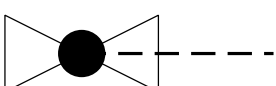
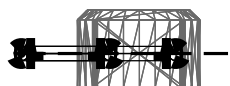
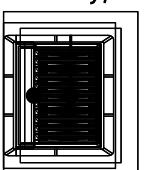





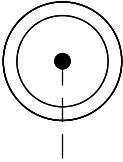
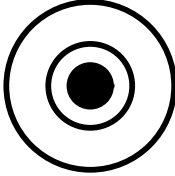
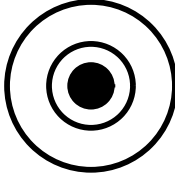
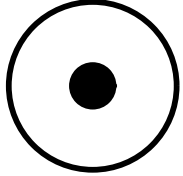
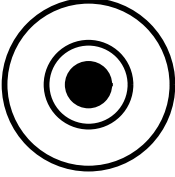
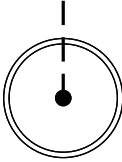
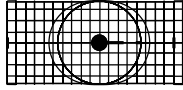
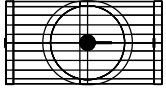
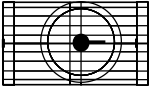

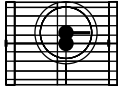





Plan - Headwall - 36 Dia 	Plan - Sloped ES - 36 Dia 	Plan - Sloped ES - 30 Dia 	Plan - Sloped ES - 24 Dia
Plan - Sloped ES - 18 Dia 	Plan - Sloped ES - 15 Dia 	Plan - FES - 84 Steel 	Plan - FES - 78 Steel
Plan - FES - 72 Steel 	Plan - FES - 66 Steel 	Plan - FES - 60 Steel 	Plan - FES - 54 Steel
Plan - FES - 48 Steel 	Plan - FES - 42 Steel 	Plan - FES - 36 Steel 	Plan - FES - 30 Steel
Plan - FES - 24 Steel 	Plan - FES - 21 Steel 	Plan - FES - 18 Steel 	Plan - FES - 15 Steel
Plan - FES - 12 Steel 	Plan - Sloped ES - 18 Dia 	Plan - Sloped ES - 21 Dia 	Plan - Sloped ES - 60 Dia
Plan - Sloped ES - 54 Dia 	Plan - Sloped ES - 48 Dia 	Plan - Sloped ES - 42 Dia 	Plan - Sloped ES - 36 Dia
Plan - Sloped ES - 30 Dia 	Plan - Sloped ES - 27 Dia 	Plan - Sloped ES - 24 Dia 	Plan - Manhole B 48in

4-1

<p>Plan - Manhole B 60in</p> 	<p>Plan - Manhole B 72in</p> 	<p>Plan - Manhole B 84in</p> 	<p>Plan - Manhole B 96in</p> 
<p>Plan - Manhole B 108in</p> 	<p>Plan - Manhole B 20in</p> 	<p>Plan - Inlet G 24inch BeeHive</p> 	<p>Bottom - Catch Basin 5 Dia</p> 
<p>Bottom - Catch Basin 6 Dia</p> 	<p>Bottom - Catch Basin 7 Dia</p> 	<p>Bottom - Catch Basin 8 Dia</p> 	<p>Bottom - Catch Basin 9 Dia</p> 
<p>Bottom - Catch Basin 10 Dia</p> 	<p>Top - Manhole Flat Cover</p> 	<p>Top - 5ft Manhole Flat Cover</p> 	<p>Top - 6ft Inlet Flat Cover G 5ft</p> 
<p>Top - Inlet Flat Cover G 6ft</p> 	<p>Top - Inlet Flat Cover E 5ft</p> 	<p>Top - Inlet Flat Cover E 6ft</p> 	<p>Top - Inlet Flat Cover C 5ft</p> 
<p>Top - Inlet Flat Cover C 6ft</p> 	<p>Bottom - Ball</p> 	<p>Bottom - Conflict Borehole</p> 	<p>Bottom - Conflict New</p> 
<p>Headwall - Type A</p> 	<p>Bottom - Vault 5x4 J Bottom</p> 	<p>Bottom CB*12</p> 	<p>Plan - CB*12</p> 
<p>Plan - EWA90</p> 	<p>Plan - Gate Valve</p> 	<p>Top - Gas meter</p> 	<p>Top - Grate Type 12</p> 

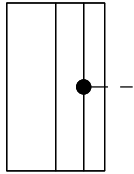
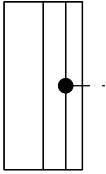
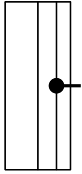



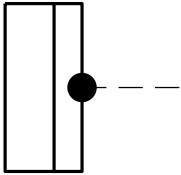
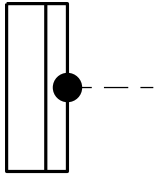
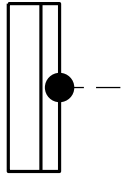

4-1



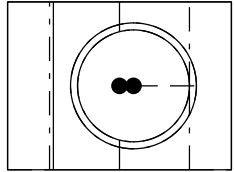
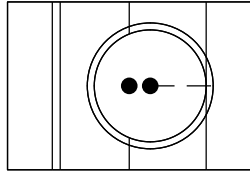
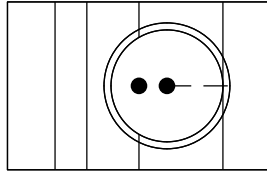
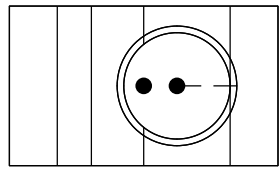
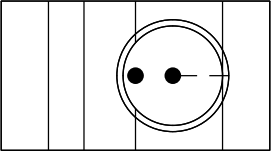
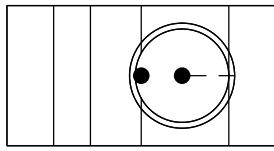
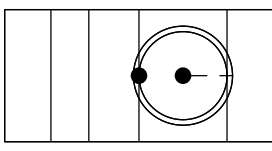
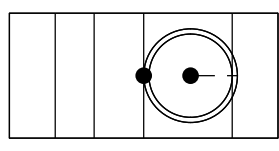
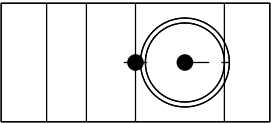

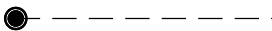
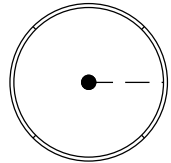
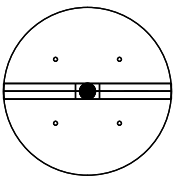
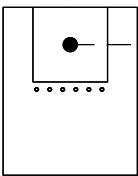
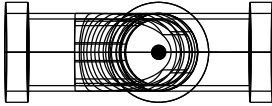
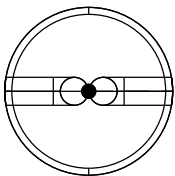
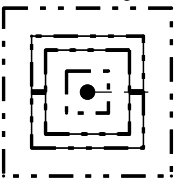
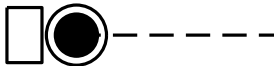
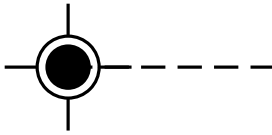
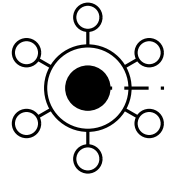
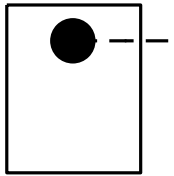
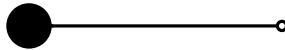

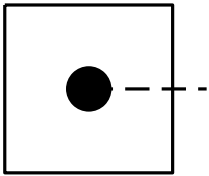
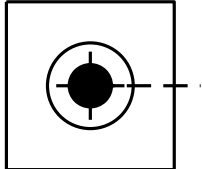
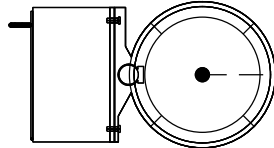
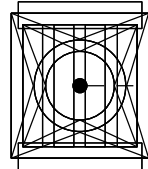
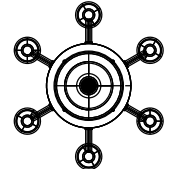
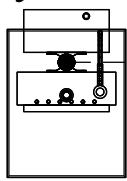
4-1

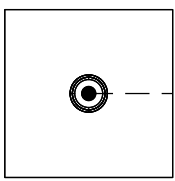

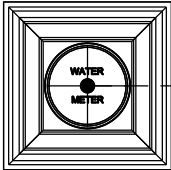
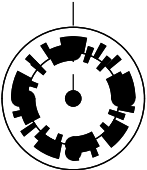
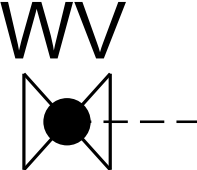
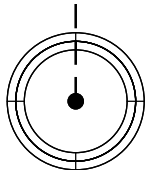
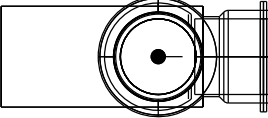
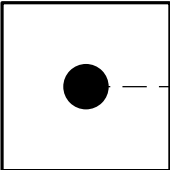
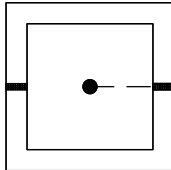
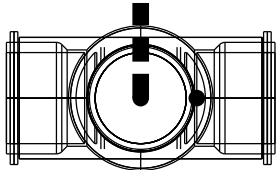
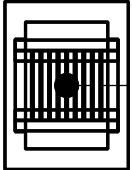
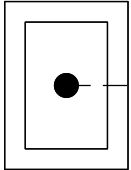
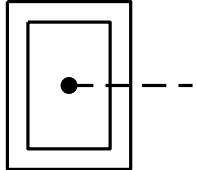
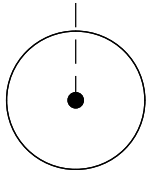

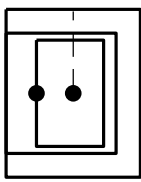
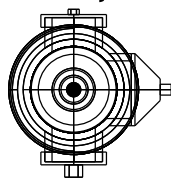
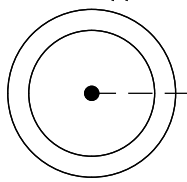
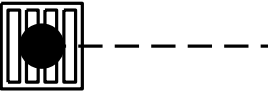

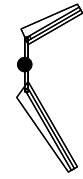
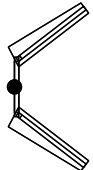
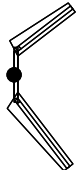

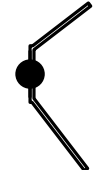
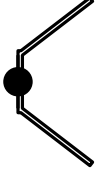
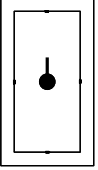
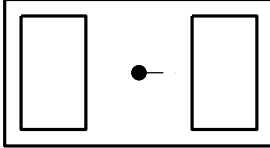
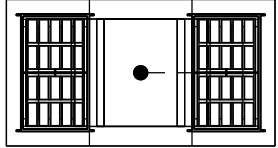

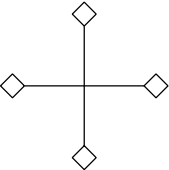

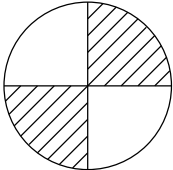



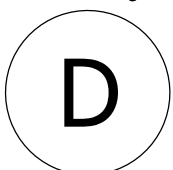
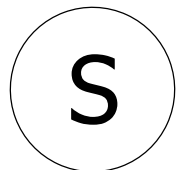

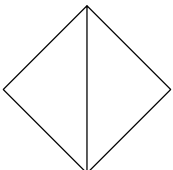

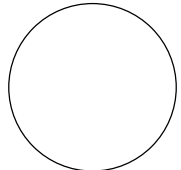
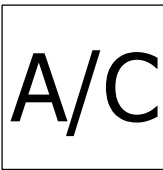
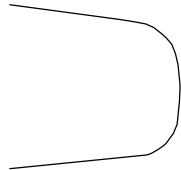
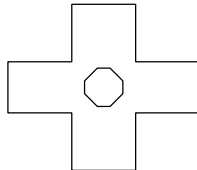

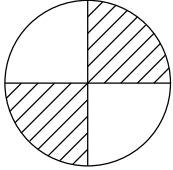
<p><i>Top - Valve</i></p> 	<p><i>Plan - Conflict New</i></p> 	<p><i>Plan - Conflict Borepit Required</i></p> 	<p><i>Plan - Conflict Borepit Complete</i></p> 
<p><i>Plan - Conflict Resolved</i></p> 	<p><i>Top - Conflict Borehole</i></p> 	<p><i>Bottom - CMT 48 Dia</i></p> 	<p><i>Bottom - CMT 54 Dia</i></p> 
<p><i>Bottom - CMT 60 Dia</i></p> 	<p><i>Bottom - CMT 66 Dia</i></p> 	<p><i>Bottom - CMT 72 Dia</i></p> 	<p><i>Bottom - CMT 78 Dia</i></p> 
<p><i>Bottom - CMT 84 Dia</i></p> 	<p><i>Bottom - CMT 90 Dia</i></p> 	<p><i>Bottom - CMT 96 Dia</i></p> 	<p><i>Bottom - CMT 102 Dia</i></p> 
<p><i>Bottom - CMT 108 Dia</i></p> 	<p><i>Bottom - CMT 114 Dia</i></p> 	<p><i>Bottom - CMT 120 Dia</i></p> 	<p><i>Bottom - CMT 126 Dia</i></p> 
<p><i>Bottom - CMT 132 Dia</i></p> 	<p><i>Bottom - CMT 138 Dia</i></p> 	<p><i>Bottom - CMT 144 Dia</i></p> 	<p><i>Headwall - Straight - 12 Dia</i></p> 
<p><i>Headwall - Straight - 15 Dia</i></p> 	<p><i>Headwall - Straight - 18 Dia</i></p> 	<p><i>Headwall - Straight - 21-24 Dia</i></p> 	<p><i>Headwall - Straight - 27-30 Dia</i></p> 
<p><i>Headwall - Straight - 36 Dia</i></p> 	<p><i>Plan - Headwall Straight - 18 Dia</i></p> 	<p><i>Plan - Headwall Straight - 18 Dia</i></p> 	<p><i>Plan - Headwall Straight - 18 Dia</i></p> 

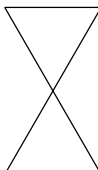

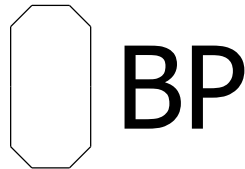

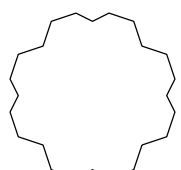

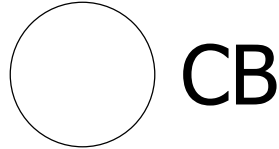









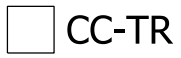
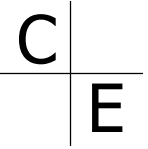

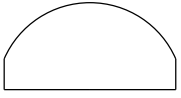
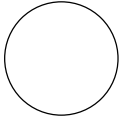

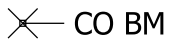
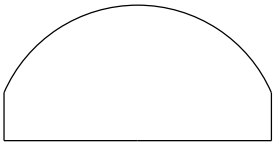
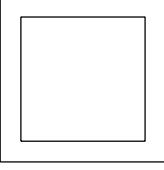

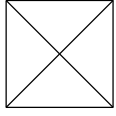
Plan - Headwall Straight	24 dia Headwall Straight	30 dia Headwall Straight	36 dia Headwall - 12 dia 3-l slope LCG
Headwall - 12 dia 4-l slope LCG	Headwall - 12 dia 6-l slope LCG	Headwall - 18 dia 3-l slope LCG	Headwall - 18 dia 4-l slope LCG
Headwall - 18 dia 6-l slope LCG	Headwall - 24 dia 4-l slope LCG	Headwall - 24 dia 6-l slope LCG	Headwall - 30 dia 3-l slope LCG
Headwall - 30 dia 4-l slope LCG	Headwall - 30 dia 6-l slope LCG	Headwall - 36 dia 3-l slope LCG	Headwall - 36 dia 4-l slope LCG
Headwall - 36 dia 6-l slope LCG	Headwall - 42 dia 3-l slope LCG	Headwall - 42 dia 4-l slope LCG	Headwall - 42 dia 6-l slope LCG
Headwall - 48 dia 3-l slope LCG	Headwall - 48 dia 4-l slope LCG	Headwall - 48 dia 6-l slope LCG	Headwall - 54 dia 3-l slope LCG
Headwall - 54 dia 4-l slope LCG	Headwall - 54 dia 6-l slope LCG	Headwall - 60 dia 3-l slope LCG	Headwall - 60 dia 4-l slope LCG
Headwall - 60 dia 6-l slope LCG	Plan - Headwall LCG 12 dia 3-l	Plan - Headwall LCG 12 dia 4-l	Plan - Headwall LCG 12 dia 6-l

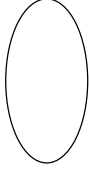

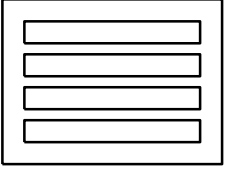



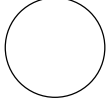
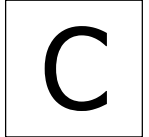





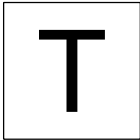
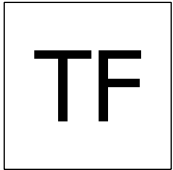

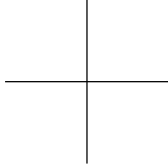
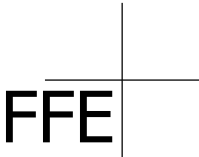
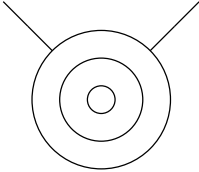

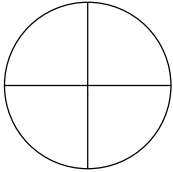
Plan - Headwall LCG 18 dia 3-l 	Plan - Headwall LCG 18 dia 3-l 	Plan - Headwall LCG 18 dia 3-l 	Plan - Headwall LCG 24 dia 3-l
Plan - Headwall LCG 24 dia 4-l 	Plan - Headwall LCG 24 dia 4-l 	Plan - Headwall LCG 30 dia 4-l 	Plan - Headwall LCG 30 dia 4-l
Plan - Headwall LCG 30 dia 6-l 	Plan - Headwall LCG 36 dia 6-l 	Plan - Headwall LCG 36 dia 6-l 	Plan - Headwall LCG 36 dia 6-l
Plan - Headwall LCG 42 dia 3-l 	Plan - Headwall LCG 42 dia 3-l 	Plan - Headwall LCG 42 dia 3-l 	Plan - Headwall LCG 48 dia 3-l
Plan - Headwall LCG 48 dia 4-l 	Plan - Headwall LCG 48 dia 4-l 	Plan - Headwall LCG 54 dia 4-l 	Plan - Headwall LCG 54 dia 4-l
Plan - Headwall LCG 54 dia 6-l 	Plan - Headwall LCG 60 dia 6-l 	Plan - Headwall LCG 60 dia 6-l 	Plan - Headwall LCG 60 dia 6-l
Headwall - FES - 54 Dia 3-l 	Top - Hydrant 3D 	Plan - Node 	Bottom - Stub
Top - Valve2 	Top - Grate Type 12 Round 	Bottom - MB Type 1 - 48 	Bottom - MB Type 1 - 54 Dia



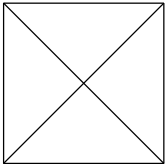
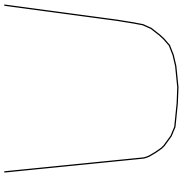
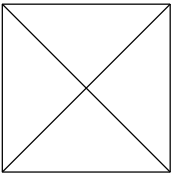
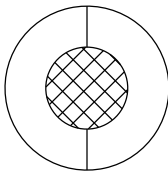
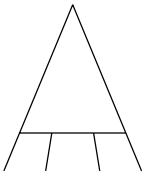





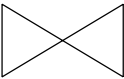
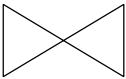
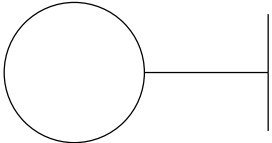
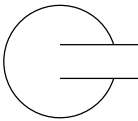

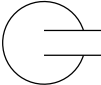



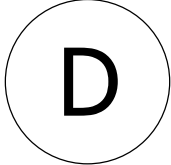
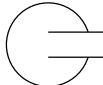

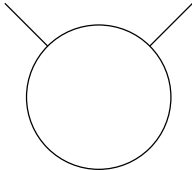
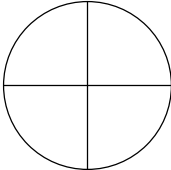
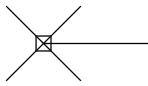
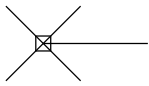
Bottom - MB Type I - 60 	Bottom - MB Type I - 66 	Bottom - MB Type I - 72 	Bottom - MB Type I - 78 Dia 
Bottom - MB Type I - 84 	Bottom - MB Type I - 90 	Bottom - MB Type I - 96 	Bottom - MB Type I - 102 Dia 
Bottom - MB Type I - 108 	Plan - Utility Pole 	Bottom - PMT All 	Bottom - Electric Service Poll An 
Bottom - High Mount Foundation 	Bottom - Light Control System 	Bottom - Sewer Clean Out 	Bottom - Standard Foundation T 
Bottom - Spring Box 	Plan - Electric Service Pole 	Plan - Fire Hydrant 	Plan - High Mount Standard 
Plan - Light Control System 	Plan - Light Standard Single 	Plan - Light Standard Twin 	Plan - Sewer Cleanout 
Plan - Water Meter 	Top - Electric Service Pole 	Top - Stepper R4006 	Top - High Mount Standard Asses 
Top - Light Control System 	Top - Light Standard Single 	Top - Light Standard Twin 	Top - Sewer Clean Out 

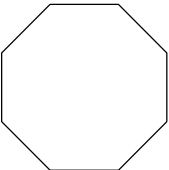
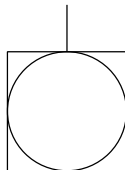
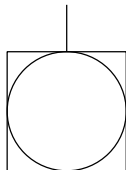
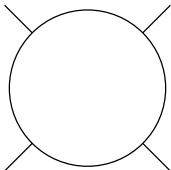
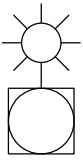
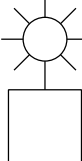
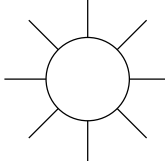
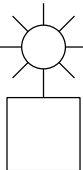
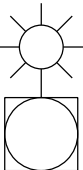
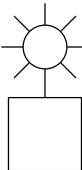

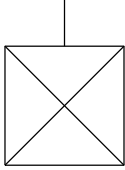

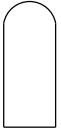





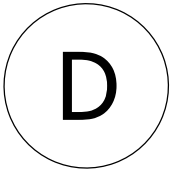
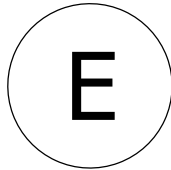
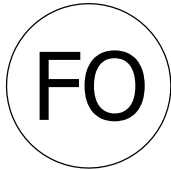

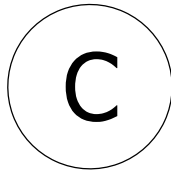
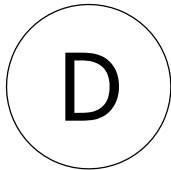
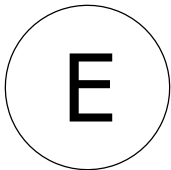
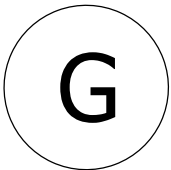
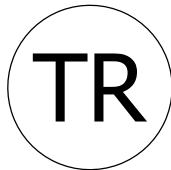
	<i>Top - Water Meter</i> 	<i>Bottom - Water Valve</i> 	<i>Plan - Water Valve</i> 	<i>Top - Water Valve</i> 
	<i>Bottom - Fire Hydrant</i> 	<i>Plan - Spring Box</i> 	<i>Bottom - Water Meter</i> 	<i>z-Bottom - Water Valve</i> 
<i>d Lateral</i>	<i>Top - Ditch Inlet Type A</i> 	<i>Bottom - Ditch Inlet Type</i> 	<i>APlan - Ditch Inlet Type A</i> 	<i>Bottom - Utility Pole</i> 
<i>type RI</i>	<i>Top - Utility Pole</i> 	<i>Plan - CB*12 Rect</i> 	<i>Top - Fire Hydrant</i> 	<i>Bottom - Scupper R4006</i> 
	<i>Plan - Scupper R-4006</i> 	<i>Headwall - Box 3 at 16ft x 14ft 60sk</i> 	<i>Headwall Box 3-16x14-60sk</i> 	<i>Headwall Box 12ft x 12ft 60 sk</i> 
	<i>Headwall - Box 12ft x 12ft 90sk</i> 	<i>Headwall - Box 12ft x 12ft 75sk</i> 	<i>Headwall Box 12x12 75sk</i> 	<i>Headwall Box 12x12 75 sk</i> 
<i>mbly</i>	<i>Plan - Headwall Box 12x12 90sk</i> 	<i>Bottom - Vault 94x44</i> 	<i>Plan - CB*15</i> 	<i>Top - Grate Type 15</i> 

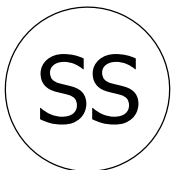
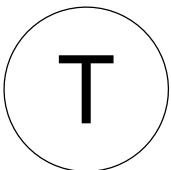
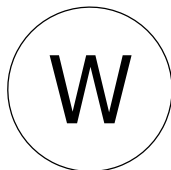

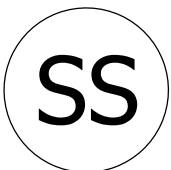
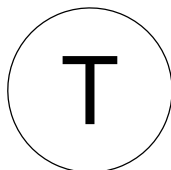
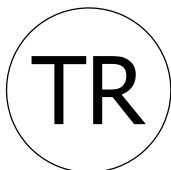

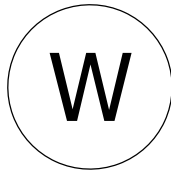
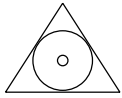

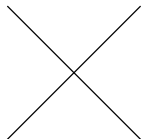
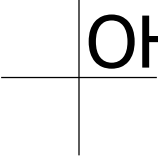
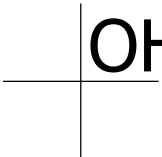

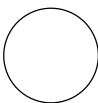



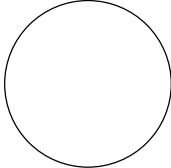
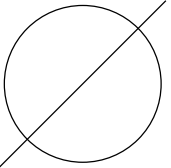

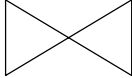

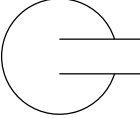
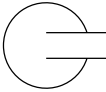
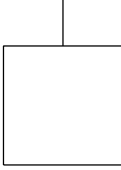



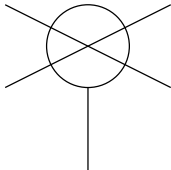
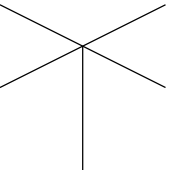

<i>Default</i>	<i>antiqs</i> 	<i>ztemp</i> 	<i>boreho</i> 
<i>BROKENLINE</i> 	<i>Flow Arrow</i> 	<i>GRAIL</i> 	<i>Manhole_Drainage</i> 
<i>Manhole_Sanitary</i> 	<i>MARKI</i> 	<i>MISC</i> 	<i>NAIL</i> 
<i>oscirc</i> 	<i>PACU</i> 	<i>PANC</i> 	<i>PASE</i> 
<i>PASP</i> <p>ASPHALT</p>	<i>PBLT</i> <p>BLACKTOP</p>	<i>PBMK</i> 	<i>pavevm</i> 
<i>pbmkev</i> 	<i>PBOL</i> <p>BOULDER</p>	<i>PBRK</i> 	<i>PBRP</i> 
<i>PBRs</i> <p>BRUSH</p>	<i>PBSH</i> 	<i>PBSP</i> 	<i>PBTH</i> 
<i>PBUS</i> 	<i>PCAN</i> 	<i>PCBD</i> 	<i>PCBR</i> 





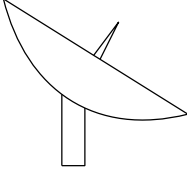
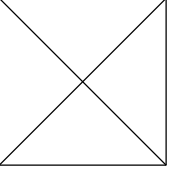

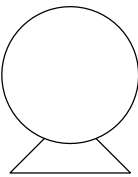

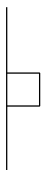

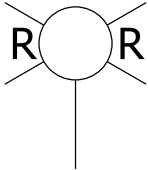
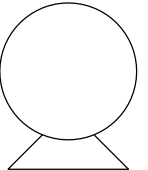
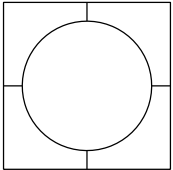
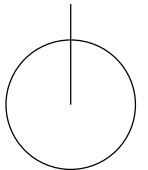

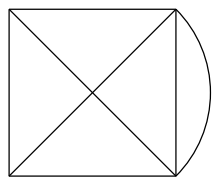
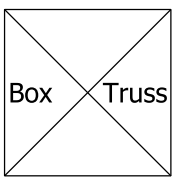
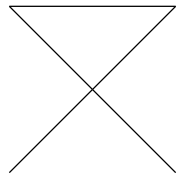
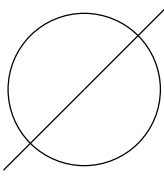

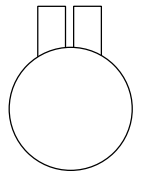
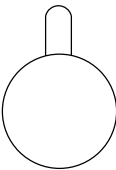
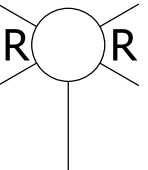

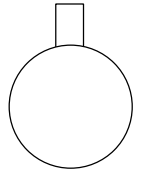
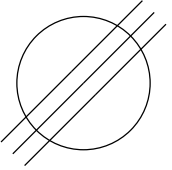
<p><i>PCBS</i></p> 	<p><i>PCCE</i></p> 	<p><i>PCCP</i></p> 	<p><i>PCCR</i></p> 
<p><i>PCCRR</i></p> 	<p><i>PCCT</i></p> 	<p><i>PCCTE</i></p> 	<p><i>PCCTR</i></p> 
<p><i>PCEL</i></p> 	<p><i>PCHE</i></p> 	<p><i>PCIN</i></p> 	<p><i>PCIS</i></p> 
<p><i>PCLM</i></p> 	<p><i>PCON</i></p> 	<p><i>PCOU</i></p> 	<p><i>PCRB</i></p> 
<p><i>PCRS</i></p> <p>CRUSHED STONE</p>	<p><i>PCRT</i></p> <p>CONCRETE</p>	<p><i>PCST</i></p> 	<p><i>PCTR</i></p> 
<p><i>PCTS</i></p> 	<p><i>PCTY</i></p> 	<p><i>PCWV</i></p> 	<p><i>PDEL</i></p> 
<p><i>PDHC</i></p> 	<p><i>PDID</i></p> 	<p><i>PDIN</i></p> 	<p><i>PDNR</i></p> 
<p><i>PDOT</i></p> 	<p><i>PDRH</i></p> 	<p><i>PEDC</i></p> 	<p><i>PEDE</i></p> 

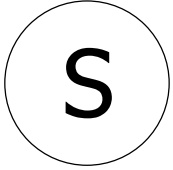



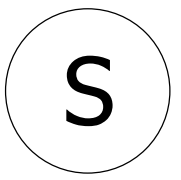

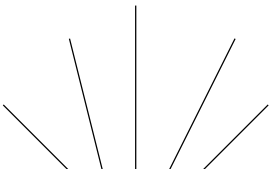

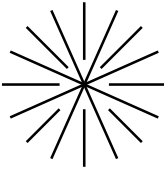
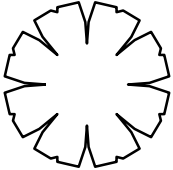
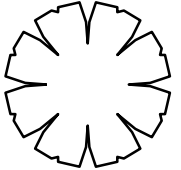

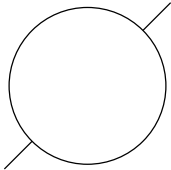

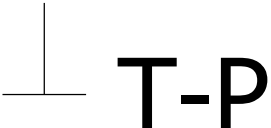
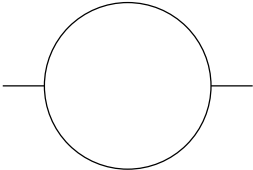

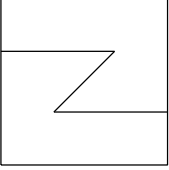
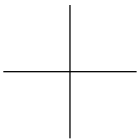

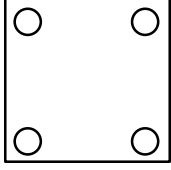
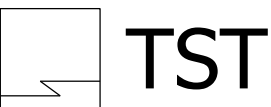
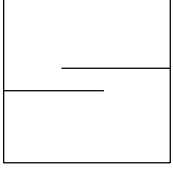



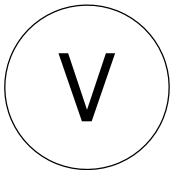
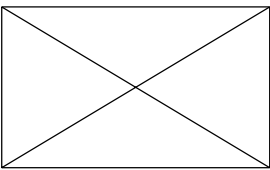

<p><i>PEDF</i></p> 	<p><i>PEDG</i></p> 	<p><i>PEDT</i></p> 	<p><i>PELB</i></p> 
<p><i>PELM</i></p> 	<p><i>PELR</i></p> 	<p><i>PELV</i></p> 	<p><i>PERT</i></p> <p>EARTH</p>
<p><i>PFEL</i></p> 	<p><i>PFHY</i></p> 	<p><i>PFLP</i></p> 	<p><i>PFLY</i></p> 
<p><i>PFOM</i></p> 	<p><i>PGAM</i></p> 	<p><i>PGAR</i></p> 	<p><i>PGBD</i></p> 
<p><i>PGCA</i></p> 	<p><i>PGDB</i></p> 	<p><i>PGFC</i></p> 	<p><i>PGLT</i></p> 
<p><i>PGMW</i></p> 	<p><i>PGNW</i></p> 	<p><i>PGPS</i></p> 	<p><i>PGPT</i></p> 
<p><i>PGRS</i></p> <p>GRASS</p>	<p><i>PGRT</i></p> <p>DIRT</p>	<p><i>PGRV</i></p> <p>GRAVEL</p>	<p><i>PGSN</i></p>  <p>GNV</p>
<p><i>PGSO</i></p>  <p>GV</p>	<p><i>PGSP</i></p>  <p>GPV</p>	<p><i>PGUY</i></p> 	<p><i>PGVP</i></p>  <p>GVP</p>

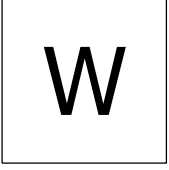
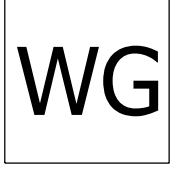
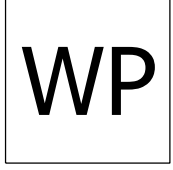



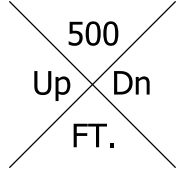





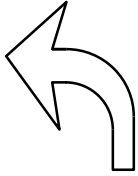
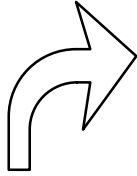





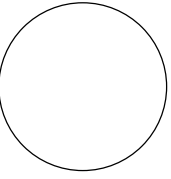

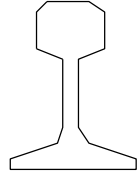
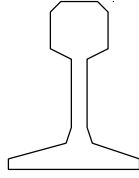
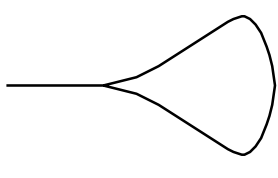

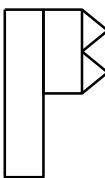
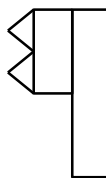
<p><i>PGVT</i></p>  <p>GVT</p>	<p><i>PGWL</i></p>  <p>NGW</p>	<p><i>PGWS</i></p>  <p>GW</p>	<p><i>PHHL</i></p>  <p>H</p>
<p><i>PHMD</i></p> 	<p><i>PHPT</i></p>  <p>HPT</p>	<p><i>PHUB</i></p>  <p>WH</p>	<p><i>PHYD</i></p> 
<p><i>PICF</i></p> 	<p><i>PIDT</i></p>  <p>BM</p>	<p><i>PIFC</i></p>  <p>BM</p>	<p><i>PIPO</i></p>  <p>IP-0</p>
<p><i>PIRP</i></p>  <p>IRP</p>	<p><i>PISL</i></p> 	<p><i>PJNT</i></p> 	<p><i>PJPT</i></p> 
<p><i>PLIT</i></p> 	<p><i>PLJP</i></p> 	<p><i>PLPP</i></p> 	<p><i>PLPT</i></p> 
<p><i>PLTD</i></p> 	<p><i>PLTJ</i></p> 	<p><i>PLTP</i></p> 	<p><i>PMAG</i></p>  <p>MAG</p>
<p><i>PMAP</i></p> 	<p><i>PMAT</i></p> <p>OTHER</p>	<p><i>PMBD</i></p>  <p>MB-D</p>	<p><i>PMBM</i></p>  <p>MB-M</p>
<p><i>PMB0</i></p>  <p>MB</p>	<p><i>PMB5</i></p>  <p>MB-X</p>	<p><i>PMBU</i></p>  <p>MB-USPS</p>	<p><i>PMBX</i></p>  <p>MB</p>

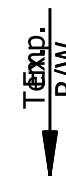

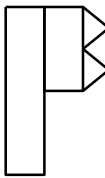
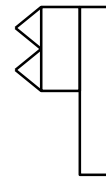
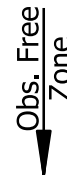





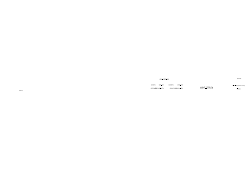

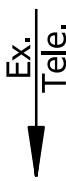





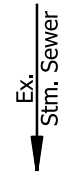

<p><i>PMCT</i></p> 	<p><i>PMDR</i></p> 	<p><i>PMEL</i></p> 	<p><i>PMFO</i></p> 
<p><i>PMGA</i></p> 	<p><i>PMGS</i></p> 	<p><i>PMHC</i></p> 	<p><i>PMHD</i></p> 
<p><i>PMHE</i></p> 	<p><i>PMHG</i></p> 	<p><i>PMHI</i></p> 	<p><i>PMHO</i></p> 
<p><i>PMHS</i></p> 	<p><i>PMHT</i></p> 	<p><i>PMHW</i></p> 	<p><i>PMON</i></p>  <p>MON</p>
<p><i>PMOT</i></p> 	<p><i>PMSE</i></p> 	<p><i>PMTE</i></p> 	<p><i>PMTS</i></p> 
<p><i>PMUL</i></p> <p>MULCH</p>	<p><i>PMUS</i></p>  <p>MB-USPS</p>	<p><i>PMWA</i></p> 	<p><i>PNGS</i></p>  <p>NGS</p>
<p><i>PNGW</i></p>  <p>NGW</p>	<p><i>PNGWS</i></p>  <p>GW</p>	<p><i>PNUM</i></p> 	<p><i>POHW</i></p>  <p>OHW</p>
<p><i>PORD</i></p>  <p>OHW</p>	<p><i>POWN</i></p>  <p>Property Owner</p>	<p><i>PPBX</i></p>  <p>PB</p>	<p><i>PPIN</i></p>  <p>IPn</p>



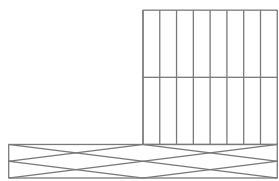
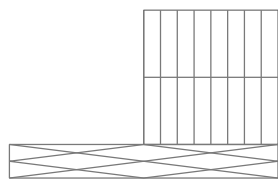
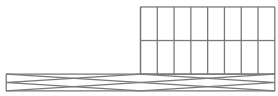
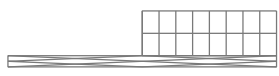
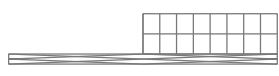

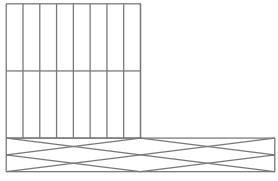
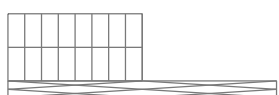
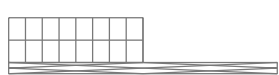
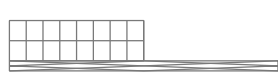

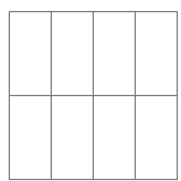

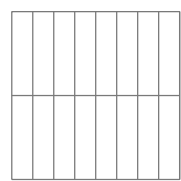

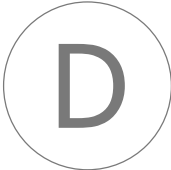

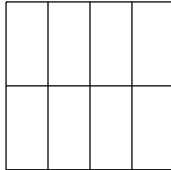
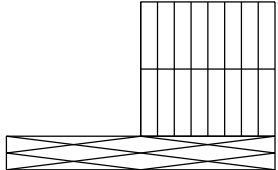
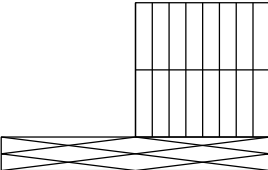
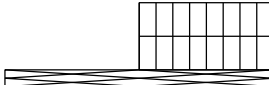
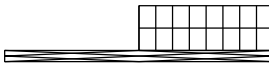
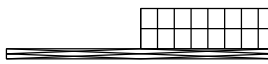

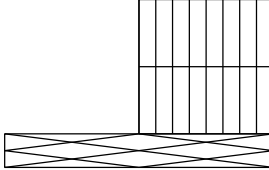
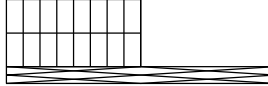
<p>PPKN</p>  <p>PK</p>	<p>PPLB</p>  <p>PB</p>	<p>PPLE</p> 	<p>PPOL</p> 
<p>PPON</p> <p>POND</p>	<p>PPSN</p> 	<p>PPSO</p>  <p>PV</p>	<p>PPST</p>  <p>PPST</p>
<p>PPVP</p>  <p>PVP</p>	<p>PPVT</p>  <p>PVT</p>	<p>PPWP</p> 	<p>PRDN</p>  <p>RN</p>
<p>PREO</p>  <p>RB-0</p>	<p>PRES</p> 	<p>PROC</p> <p>BOULDER</p>	<p>PRRS</p>  <p>RR</p>
<p>PRSC</p>  <p>CR</p>	<p>PRSE</p>  <p>ER</p>	<p>PRSL</p> 	<p>PRSN</p> 
<p>PRST</p>  <p>TR</p>	<p>PRSW</p>  <p>WR</p>	<p>PRWC</p>  <p>RW-C</p>	<p>PRWG</p>  <p>RW-G</p>
<p>PRWS</p>  <p>RW-S</p>	<p>PSAC</p>  <p>PSAC</p>	<p>PSAT</p> 	<p>PSBD</p> 
<p>PSCA</p>  <p>PSCA</p>	<p>PSGL</p> 	<p>PSGLB</p>  <p>LD</p>	<p>PSGN</p> 

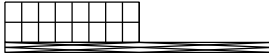
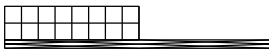

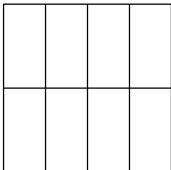
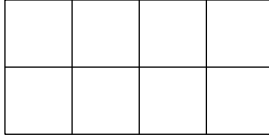
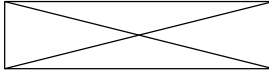
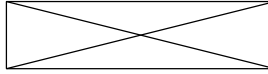
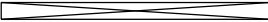
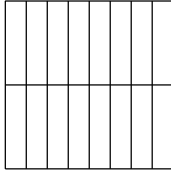
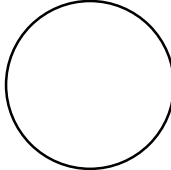

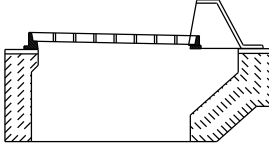
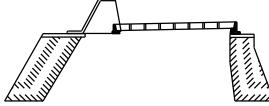
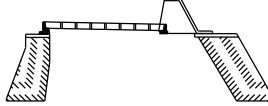

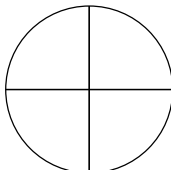
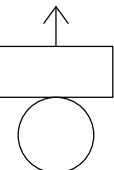
<p><i>PSGRR</i></p> 	<p><i>PSGTN</i></p> 	<p><i>PSGTS</i></p> 	<p><i>PSHD</i></p> 
<p><i>PSLD</i></p> 	<p><i>PSLM</i></p> 	<p><i>PSLT</i></p> 	<p><i>PSNBT</i></p> 
<p><i>PSNC</i></p> 	<p><i>PSNCS</i></p> 	<p><i>PSND</i></p> 	<p><i>PSNDA</i></p> 
<p><i>PSNMT</i></p> 	<p><i>PSNR</i></p> 	<p><i>PSNS</i></p> 	<p><i>PSNSA</i></p> 
<p><i>PSNTC</i></p> 	<p><i>PSPH</i></p> 	<p><i>PSPT</i></p> 	<p><i>PSRC</i></p> 
<p><i>PSSA</i></p> 	<p><i>PSSC</i></p> 	<p><i>PSST</i></p> 	<p><i>PSTK</i></p> 
<p><i>PSTN</i></p> <p>STONE</p>	<p><i>PSTO</i></p> 	<p><i>PSTP</i></p> 	<p><i>PSWP</i></p> 
<p><i>PTBM</i></p> 	<p><i>PTCS</i></p> 	<p><i>PTDR</i></p> 	<p><i>PTDS</i></p> 



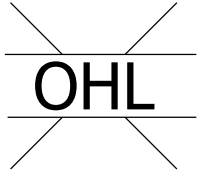

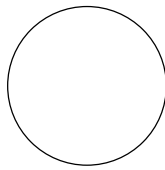
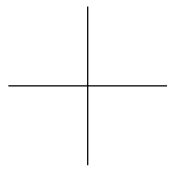



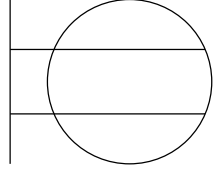
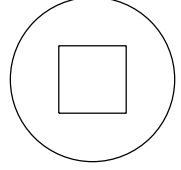
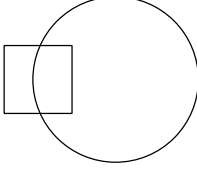
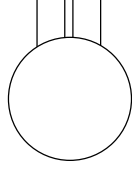
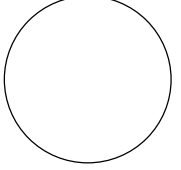

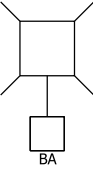
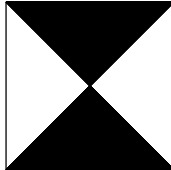
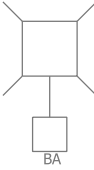
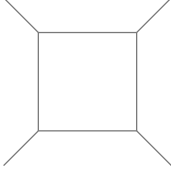
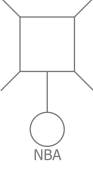
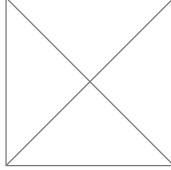
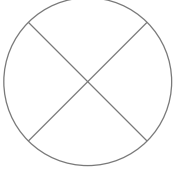
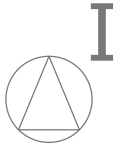
<p><i>PTEL</i></p> 	<p><i>PTER</i></p> 	<p><i>PTFP</i></p> 	<p><i>PTGP</i></p> 
<p><i>PTLM</i></p> 	<p><i>PTOW</i></p> 	<p><i>PTRA</i></p> 	<p><i>PTRV</i></p> 
<p><i>PTSP</i></p> 	<p><i>PTST</i></p> 	<p><i>PTUB</i></p> 	<p><i>PTVR</i></p> 
<p><i>PUSC</i></p> 	<p><i>PUSG</i></p> 	<p><i>PVAC</i></p> 	<p><i>PVBX</i></p> 
<p><i>PWAM</i></p> 	<p><i>PWAR</i></p> 	<p><i>PWDH</i></p> 	<p><i>PWDS</i></p> 
<p><i>PWED</i></p> <p>WEEDS</p>	<p><i>PWEL</i></p> 	<p><i>PWGT</i></p> 	<p><i>PWLP</i></p> 
<p><i>PWMT</i></p> 	<p><i>PWOD</i></p> <p>WOODS</p>	<p><i>PWSO</i></p> 	<p><i>PWSV</i></p> 
<p><i>PWTR</i></p> 	<p><i>PZZZ</i></p> 	<p><i>SN_ARTHR</i></p> 	<p><i>SN_EARCLT</i></p> 

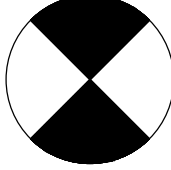
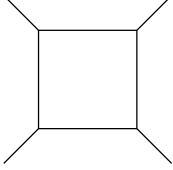
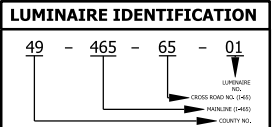
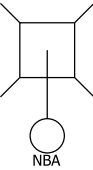

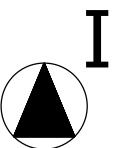
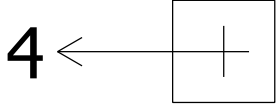
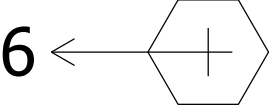
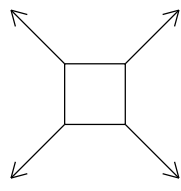
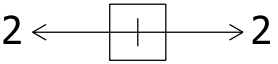

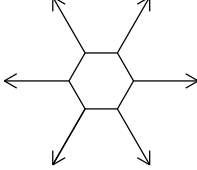
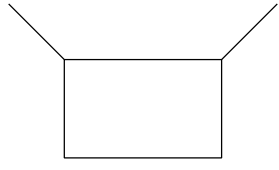
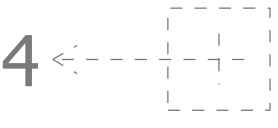

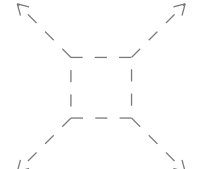

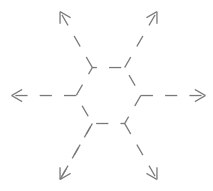
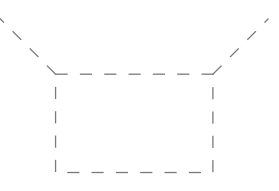















<p>SN_EARLT</p> 	<p>SN_EARRT</p> 	<p>SN_EONLY</p> 	<p>SN_RR</p> 
<p>SN_SCHOOL</p> 	<p>SN_XING</p> 	<p>nrthsymb</p> 	<p>pipein</p> 
<p>northsy</p> 	<p>pres00</p> 	<p>prestr</p> 	<p>tadpl</p> 
<p>pgarro</p> 	<p>clrzone</p> 	<p>grailt</p> 	<p>grailrt</p> 
<p>obsfzn</p> 	<p>rowextg</p> 	<p>rowtemp</p> 	<p>rwarro</p> 
<p>clrzonem</p> 	<p>grailtm</p> 	<p>grailrtm</p> 	<p>obsfznm</p> 
<p>pgarrom</p> 	<p>rowextgm</p> 	<p>rwarrom</p> 	<p>rowtempm</p> 
<p>SN_RR-2</p> 	<p>tinfo</p> 	<p>CrossSectionTags</p> 	<p>BridgeLayout</p> <p>Bridge Layout</p>

<p><i>CrossSection</i></p> <p>Cross Section</p>	<p><i>PlanProfile</i></p> <p>Plan Profile</p>	<p><i>ConstructionDetail</i></p> <p>Construction Detail</p>	<p><i>PlanSheetTags</i></p>
<p><i>XSECExGas</i></p> 	<p><i>XSECExTele</i></p> 	<p><i>XSECExWater</i></p> 	<p><i>XSECExCable</i></p> 
<p><i>XSECExElectric</i></p> 	<p><i>XSECExHPG</i></p> 	<p><i>XSECExOther</i></p> 	<p><i>XSECExPetroleum</i></p> 
<p><i>XSECExSanSwr</i></p> 	<p><i>XSECExStmSan.</i></p> 	<p><i>XSECExStmSewer</i></p> 	<p><i>XSECExFiber</i></p> 
<p><i>XSECExSewer</i></p> 	<p><i>XSECExUtilPole</i></p> 	<p><i>Ex_Inlet_Combo</i></p> 	<p><i>Ex_Inlet_Combo_1xl</i></p> 
<p><i>Ex_Inlet_Combo_2xl</i></p> 	<p><i>Ex_Inlet_Combo_3.0xl</i></p> 	<p><i>Ex_Inlet_Combo_3.33xl</i></p> 	<p><i>Ex_Inlet_Combo_6xl</i></p> 
<p><i>Ex_Inlet_ComboL_1xl</i></p> 	<p><i>Ex_Inlet_ComboL_2xl</i></p> 	<p><i>Ex_Inlet_ComboL_3.0xl</i></p> 	<p><i>Ex_Inlet_ComboL_3.33xl</i></p> 
<p><i>Ex_Inlet_ComboL_6xl</i></p> 	<p><i>Ex_Inlet_CurbGrate</i></p> 	<p><i>Ex_Inlet_CurbOpening</i></p> 	<p><i>Ex_Inlet_MedianDrop</i></p> 

<p><i>Ex_Manhole_Drainage</i></p> 	<p><i>Ex_Manhole_Sanitary</i></p> 	<p><i>Grate</i></p> 	<p><i>Inlet_Combo</i></p> 
<p><i>Inlet_Combo_1xl</i></p> 	<p><i>Inlet_Combo_2xl</i></p> 	<p><i>Inlet_Combo_3.0xl</i></p> 	<p><i>Inlet_Combo_3.33xl</i></p> 
<p><i>Inlet_Combo_4xl</i></p> 	<p><i>Inlet_Combo_6xl</i></p> 	<p><i>Inlet_ComboL_1xl</i></p> 	<p><i>Inlet_ComboL_2xl</i></p> 
<p><i>Inlet_ComboL_3.0xl</i></p> 	<p><i>Inlet_ComboL_3.33xl</i></p> 	<p><i>Inlet_ComboL_4xl</i></p> 	<p><i>Inlet_ComboL_6xl</i></p> 
<p><i>Inlet_CurbGrate</i></p> 	<p><i>Inlet_CurbGrate_2xl</i></p> 	<p><i>Inlet_CurbOpening</i></p> 	<p><i>Inlet_CurbOpening_1</i></p> 
<p><i>Inlet_CurbOpening_4</i></p> 	<p><i>Inlet_MedianDrop</i></p> 	<p><i>Pipe</i></p> 	<p><i>Sign Xsection</i></p> 
<p><i>Tree Xsection</i></p> 	<p><i>xBAD XS_Inlet_Combo_3.0 XS_Inlet_Combo_3.0</i></p> 	<p><i>XS_Inlet_Combo_3.0</i></p> 	<p><i>XS_Inlet_ComboL_3.0</i></p> 
<p><i>DS_LINFO</i></p> 	<p><i>SectionCorner</i></p> 	<p><i>PPSP</i></p> 	<p><i>PMSP</i></p> 

<i>POHL</i> 	<i>PHAR</i> 	<i>CG_Circle</i> 	<i>CG_Plus</i> 
<i>lrrtinfo</i> 	<i>PMBK</i> 	<i>PSUM</i> 	<i>PEBX</i> 
<i>PSCO</i> 	<i>PPBN</i> 	<i>PODS</i> 	<i>PCUT</i> 

<p><i>Default</i></p>	<p><i>LG_BA</i></p> 	<p><i>LG_CABMAR</i></p> 	<p><i>LG_EXBA</i></p> 
<p><i>LG_EXLUMIN</i></p> 	<p><i>LG_EXNB</i></p> 	<p><i>LG_EXCABMAR</i></p> 	<p><i>LG_EXHH</i></p> 
<p><i>LG_EXSVPT I</i></p> 	<p><i>LG_EXSVPT II</i></p> 	<p><i>LG_HH</i></p> 	<p><i>LG_LUMIN</i></p> 
<p><i>LG_LUMINID</i></p> 	<p><i>LG_NB</i></p> 	<p><i>LG_SVPT II</i></p> 	<p><i>LG_SVPT I</i></p> 
<p><i>LG_T40</i></p> 	<p><i>LG_T60</i></p> 	<p><i>LG_T490</i></p> 	<p><i>LG_T4180</i></p> 
<p><i>LG_T6180</i></p> 	<p><i>LG_T6360</i></p> 	<p><i>LG_UP</i></p> 	<p><i>LG_EXT40</i></p> 
<p><i>LG_EXT60</i></p> 	<p><i>LG_EXT490</i></p> 	<p><i>LG_EXT4180</i></p> 	<p><i>LG_EXT6180</i></p> 
<p><i>LG_EXT6360</i></p> 	<p><i>LG_EXUP</i></p> 		

<p>CONC</p> 	<p>SOLID</p> 	<p>SWP</p> 	<p>HONEY</p> 
<p>STONWL</p> 	<p>GRADE1</p> 	<p>GRADE2</p> 	<p>CONCR2</p> 
<p>EARTH</p> 	<p>GRASS</p> 	<p>RCK</p> 	<p>WETLNDS</p> 
<p>MAGAL</p> 	<p>STEEL</p> 	<p>RUBBER</p> 	<p>BRONZE</p> 
<p>TITAN</p> 	<p>THERM</p> 	<p>TICK</p> 	<p>ST_EARTH</p> 
<p>ST_RCK</p> 	<p>ST_STEEL</p> 	<p>ST_CONC</p> 	<p>DOTS</p> 
<p>SAND</p> 			









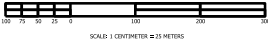
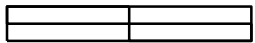
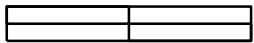
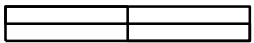
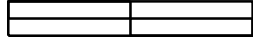
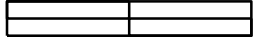
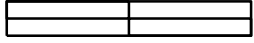
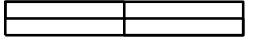
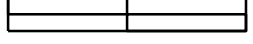
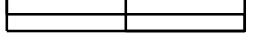
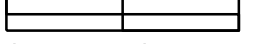
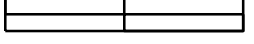
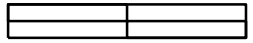
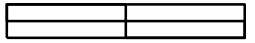
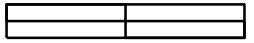

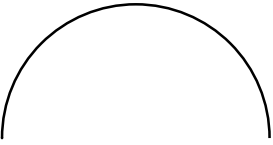
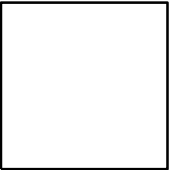
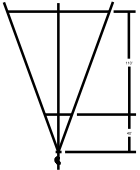
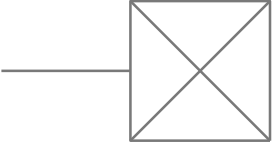
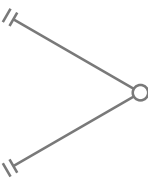

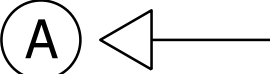

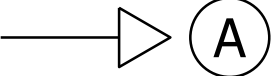



Default	EA_ARCLT 	EA_ARCRT 	EA_ARLT
EA_ARRT 	EA_ARTHR 	SN_ARCLT 	SN_ARCRT
SN_ARLT 	SN_ARRT 	SN_ARTHR 	SN_EARCLT
SN_EARCRT 	SN_EARLT 	SN_EARRT 	SN_EARTHR
SN_EONLY 	SN_ERR 	SN_ESCHOO 	SN_EXING
SN_LML 	SN_ONLY 	SN_RR 	SN_SCHOOL
SN_XING 	SG_LA 	SG_LLA 	SG_RA
SG_RLAR 	SG_SLA 	SG_SRA 	SG_SRL

SN_INTSYMACCSY



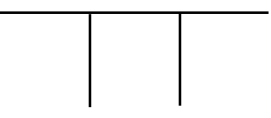
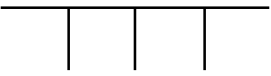
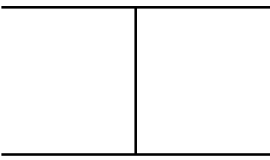

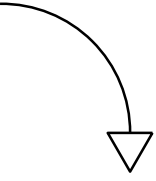
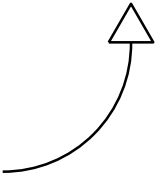
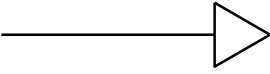
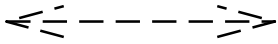
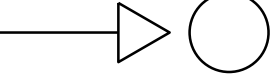
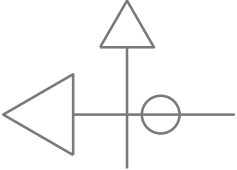





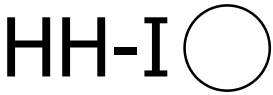



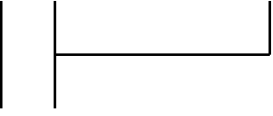



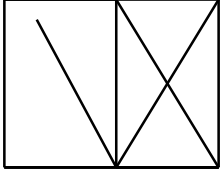
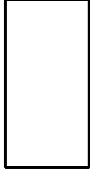
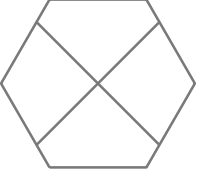

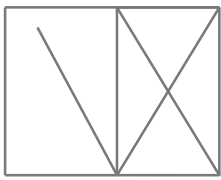

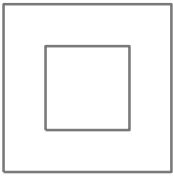

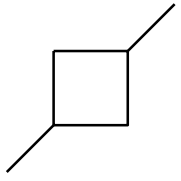
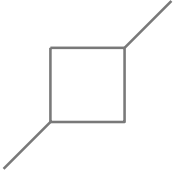



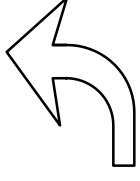
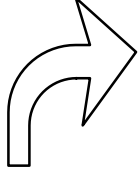















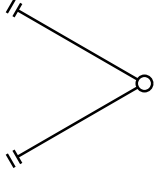

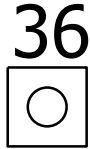
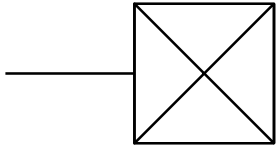
SN_INTSYMACCSY 			

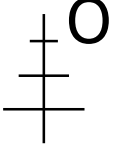
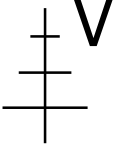
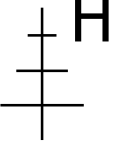
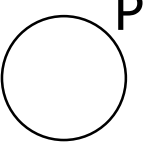

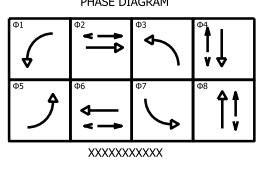



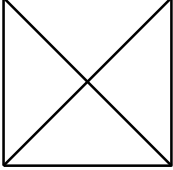
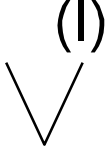
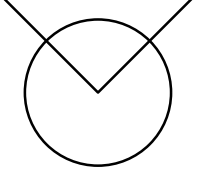
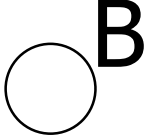
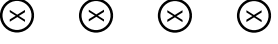
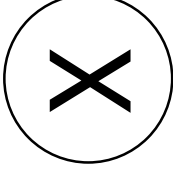
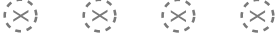



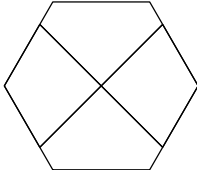

<p>SV_SCALE25</p> 	<p>SV_SCALE50</p> <p>SCALE: 1" = 50'</p> 	<p>SV_SCALE10</p> <p>SCALE: 1" = 10'</p> 	<p>SV_SCALE20</p> <p>SCALE: 1" = 20'</p> 
<p>SV_SCALE30</p> <p>SCALE: 1" = 30'</p> 	<p>SV_SCALE40</p> <p>SCALE: 1" = 40'</p> 	<p>SV_SCALE60</p> <p>SCALE: 1" = 60'</p> 	<p>SV_SCALE100</p> <p>SCALE: 1" = 100'</p> 
<p>SV_SCALE200</p> <p>SCALE: 1" = 200'</p> 	<p>SV_SCALE500</p> <p>SCALE: 1" = 500'</p> 	<p>SV_SCALE1000</p> <p>SCALE: 1" = 1000'</p> 	<p>SV_SCALE400</p> <p>SCALE: 1" = 400'</p> 
<p>SV_SCALE600</p> <p>SCALE: 1" = 600'</p> 	<p>SV_SCALE300</p> <p>SCALE: 1" = 300'</p> 	<p>SV_SCALE800</p> <p>SCALE: 1" = 800'</p> 	

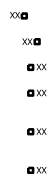





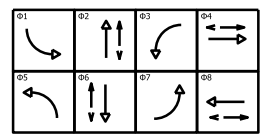

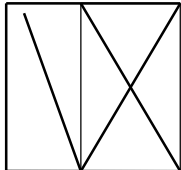















<p>INLETC</p> 	<p>INLETD</p> 	<p>VC_ENG</p> 	<p>ECANT</p> 
<p>EDG</p> 	<p>24SSP</p> 	<p>IFADN</p> 	<p>IFALT</p> 
<p>IFAUP</p> 	<p>IFRDN</p> 	<p>IFRT</p> 	<p>IFRUP</p> 
<p>EIFADN</p> 	<p>EIFALT</p> 	<p>EIFAUP</p> 	<p>EIFRDN</p> 
<p>EIFRLT</p> 	<p>EIFRRT</p> 	<p>EIFRT</p> 	<p>EIFRUP</p> 
<p>IFIP</p> 	<p>IF2P</p> 	<p>IF3P</p> 	<p>2FIP</p> 
<p>2F2P</p> 	<p>RT</p> 	<p>LT</p> 	<p>THRU</p> 
<p>PED</p> 	<p>IF</p> 	<p>E3FLT0</p> 	<p>E3FOP</p> 

































<i>E3FRT0</i> 	<i>E4FLT0</i> 	<i>E4FRT0</i> 	<i>E5FLT0</i>
<i>E5FRT0</i> 	<i>3FLT0P</i> 	<i>3F0</i> 	<i>3FRT0P</i>
<i>4FLT0P</i> 	<i>4FRT0P</i> 	<i>5FLT0P</i> 	<i>5FRT0P</i>
<i>3F</i> 	<i>3FRT</i> 	<i>4FLT</i> 	<i>4FRT</i>
<i>5FLT</i> 	<i>5FRT</i> 	<i>3FLT</i> 	<i>IFRRT</i>
<i>EIF</i> 	<i>E3FRT</i> 	<i>E3F</i> 	<i>E3FLT</i>
<i>E4FLT</i> 	<i>E4FRT</i> 	<i>E5FLT</i> 	<i>E5FRT</i>
<i>STUBP</i> 	<i>EUTILP</i> 	<i>DH</i> 	<i>EDH</i>

<p>HH-I</p> 	<p>EHH-I</p> 	<p>EPEDPU</p> 	<p>PEDPU</p> 
<p>PEDHD</p> 	<p>EPEDHD</p> 	<p>FCAB</p> 	<p>CABGA</p> 
<p>CABMM</p> 	<p>CABRR</p> 	<p>EPEDST</p> 	<p>EFCAB</p> 
<p>ECABGA</p> 	<p>ECABMM</p> 	<p>ECABPP</p> 	<p>ECABRR</p> 
<p>ECABUT</p> 	<p>VIDEO</p> 	<p>EVIDEO</p> 	<p>DISCO</p> 
<p>EDISCO</p> 	<p>TREE</p> 	<p>ARCLT</p> 	<p>ARCRT</p> 
<p>ARLT</p> 	<p>ARRT</p> 	<p>ARTHR</p> 	<p>ONLY</p> 
<p>SCHOOL</p> 	<p>RR</p> 	<p>XING</p> 	<p>EARCLT</p> 































<i>EARCRT</i> 	<i>EARLT</i> 	<i>EARRT</i> 	<i>EARTH</i> 
<i>EONLY</i> 	<i>ESCHOO</i> 	<i>ERR</i> 	<i>EXING</i> 
<i>DG</i> 	<i>30SSP</i> 	<i>36SSP</i> 	<i>CANT</i> 
<i>30ESSP</i> 	<i>36ESSP</i> 	<i>RAS</i> 	<i>RAV</i> 
<i>RAH</i> 	<i>PLLOOP</i> 	<i>EPLLOOP</i> 	<i>PHASE8-EW</i> 
<i>MAG</i> 	<i>MLOOP</i> 	<i>EMAG</i> 	<i>EMLLOOP</i> 
<i>ROW</i> 	<i>INCEPT</i> 	<i>FIREHY</i> 	<i>BRIDLE</i> 
<i>4LOOP</i> 	<i>LOOP</i> 	<i>E4LOOP</i> 	<i>ELOOP</i> 

<p>TAGTAB</p> <table border="1"> <thead> <tr> <th colspan="2">LOOP TAGGING TABLE</th> </tr> <tr> <th>LANE</th> <th>TAG - NUMBER</th> </tr> </thead> <tbody> <tr> <td>XXXXXXXX</td> <td>XXXXXXXXXXXX</td> </tr> <tr> <td> </td> <td> </td> </tr> </tbody> </table>	LOOP TAGGING TABLE		LANE	TAG - NUMBER	XXXXXXXX	XXXXXXXXXXXX			<p>PEDST</p> 	<p>ACCESSBOX</p> 	<p>REPEATER</p> 
LOOP TAGGING TABLE											
LANE	TAG - NUMBER										
XXXXXXXX	XXXXXXXXXXXX										
<p>WRLSDETECTOR</p> 	<p>WRLSDetectX6</p> 	<p>ERAV</p> 	<p>ERAS</p> 								
<p>ERAH</p> 	<p>HH-II</p> 	<p>EHH-II</p> 	<p>PHASE8-NS</p> <p>PHASE DIAGRAM</p>  <p>XXXXXXXXXXXX</p>								
<p>24ESSP</p> 	<p>CABPP</p> 										

<p><i>STUB</i></p> <p>∅ STUB POLE</p>	<p><i>WP45</i></p> <p> 45° CLASS II WOOD POLE WITH DOWN GUYS & ANCHOR</p>	<p><i>SSP30</i></p> <p> 30' STEEL STRAIN POLE & FOUNDATION</p>	<p><i>SSP36</i></p> <p> 36' STEEL STRAIN POLE & FOUNDATION</p>
<p><i>EUTILP</i></p> <p>∅ EX. UTILITY POLE</p>	<p><i>EWP</i></p> <p> EX. WOOD POLE WITH DOWN GUYS & ANCHOR</p>	<p><i>ESSP30</i></p> <p> EX. 30' STEEL STRAIN POLE & FOUNDATION</p>	<p><i>ESSP36</i></p> <p> EX. 36' STEEL STRAIN POLE & FOUNDATION</p>
<p><i>ECANT</i></p> <p> EX. SIGNAL CANTILEVER STRUCTURE & FOUNDATION</p>	<p><i>VIDEO</i></p> <p> VIDEO CAMERA</p>	<p><i>DISCON</i></p> <p> DISCONNECT HANGER</p>	<p><i>DETECT</i></p> <p> SIGNAL DETECTOR HOUSING</p>
<p><i>HAND</i></p> <p>○ SIGNAL HANDHOLE</p>	<p><i>OCT30</i></p> <p> OCTAGONAL LOOP, 4 TURN SERIES</p>	<p><i>EVIDEO</i></p> <p> EX. VIDEO CAMERA</p>	<p><i>EDISCO</i></p> <p> EX. DISCONNECT HANGER</p>
<p><i>EDTEC</i></p> <p> EX. SIGNAL DETECTOR HOUSING</p>	<p><i>EHANDH</i></p> <p>() EX. SIGNAL HANDHOLE</p>	<p><i>EOCTL</i></p> <p> EX. OCTAGONAL LOOP, 4 TURN SERIES</p>	<p><i>IFA</i></p> <p> TRAFFIC SIGNAL HEAD, 1 FACE 12" AMBER</p>
<p><i>IFR</i></p> <p> TRAFFIC SIGNAL HEAD, 1 FACE 12" RED</p>	<p><i>3F</i></p> <p> TRAFFIC SIGNAL HEAD, 3 FACE, 12" : RED, AMBER, GREEN</p>	<p><i>OP3F</i></p> <p> TRAFFIC SIGNAL HEAD, OPTICALLY PROGRAMMED, 3 FACE, 12" : RED, AMBER, GREEN</p>	<p><i>PED18</i></p> <p> PEDESTRIAN SIGNAL HEAD, INTERNATIONAL SYMBOLS, 18"</p>
<p><i>PUSH</i></p> <p>P PEDESTRIAN PUSH BUTTON & SIGN</p>	<p><i>EIFA</i></p> <p> EX. TRAFFIC SIGNAL HEAD, 1 FACE 12" AMBER</p>	<p><i>E3F</i></p> <p> EX. TRAFFIC SIGNAL HEAD, 3 FACE, 12" : RED, AMBER, GREEN</p>	<p><i>EOP3F</i></p> <p> EX. TRAFFIC SIGNAL HEAD, OPTICALLY PROGRAMMED, 3 FACE, 12" : RED, AMBER, GREEN</p>
<p><i>EPED</i></p> <p> EX. PEDESTRIAN SIGNAL HEAD</p>	<p><i>EPUSH</i></p> <p>EX. P EX. PEDESTRIAN PUSH BUTTON & SIGN</p>	<p><i>GSC2</i></p> <p>--- 2" GALVANIZED STEEL CONDUIT</p>	<p><i>CONCUR</i></p> <p>———— CONCRETE CURB</p>















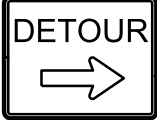









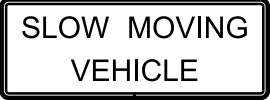



<p>CURCUT</p>  CURB AND GUTTER	<p>ROW</p>  RIGHT-OF-WAY	<p>STP</p>  24" STOP LINE	<p>PAVEME</p>  PAVEMENT MESSAGE MARKINGS
<p>ECTR2</p>  EX. 2" CONDUIT	<p>ECURB</p>  EX. CURB	<p>ECAGTR</p>  EX. CURB AND GUTTER	<p>EROW</p>  EX. RIGHT-OF-WAY
<p>EST</p>  EX. 24" STOP LINE	<p>EPAVE</p>  EX. PAVEMENT MESSAGE MARKINGS	<p>CURBA</p>  CURB RAMP TYPE A	<p>CURBC</p>  CURB RAMP TYPE C
<p>CURBD</p>  CURB RAMP TYPE D	<p>BRID</p>  BRIDLE	<p>INT</p>  INTERCEPT	<p>EXFIRE</p>  EX. FIRE HYDRANT
<p>SIPED</p>  SIGNAL PEDESTAL ON "A" FOUNDATION	<p>NEMA</p>  NEMA 2-CIRCUIT FLASHER AND CABINET	<p>GCAB</p>  CONTROLLER AND "G" CABINET ON "A" FOUNDATION	<p>MCAB</p>  TS2 CONTROLLER AND "M" CABINET MIN. 4 PHASE ON "M" FOUNDATION
<p>PICAB</p>  TS2 CONTROLLER AND "P-1" CABINET MIN. 8 PHASE ON "P-1" FOUNDATION	<p>ESIPED</p>  EX. SIGNAL PEDESTAL ON "A" FOUNDATION	<p>EFLAS</p>  EX. FLASHER CONTROLLER AND CABINET	<p>EXCAB</p>  EX. CONTROLLER AND "G" CABINET ON "A" FOUNDATION
<p>EMCAB</p>  EX. CONTROLLER AND "M" CABINET ON "M" FOUNDATION	<p>EPICAB</p>  EX. CONTROLLER AND "P-1" CABINET ON "P-1" FOUNDATION	<p>ERRSCC</p>  EX. RAILROAD SIGNAL CONTROLLER CABINET	<p>EUTIL</p>  EX. UTILITY CABINET
<p>3FL</p>  TRAFFIC SIGNAL HEAD, 3 FACE, 12" : RED, LT. AMBER ARROW, LT. GREEN ARROW	<p>3FR</p>  TRAFFIC SIGNAL HEAD, 3 FACE, 12" : RED, RT. AMBER ARROW, RT. GREEN ARROW	<p>4FL</p>  TRAFFIC SIGNAL HEAD, 4 FACE, 12" : RED, AMBER, GREEN, LT. GREEN ARROW	<p>4FR</p>  TRAFFIC SIGNAL HEAD, 4 FACE, 12" : RED, AMBER, GREEN, RT. GREEN ARROW



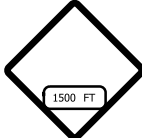

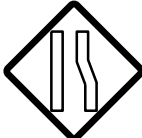
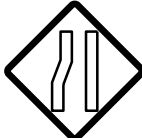

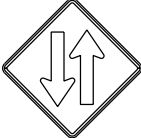





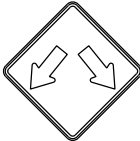





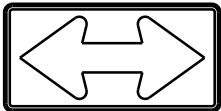
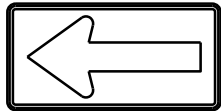
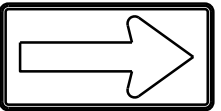

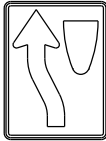



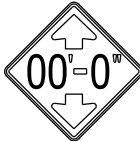



Cell Library: IN_SignalsLegend.cel





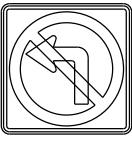

















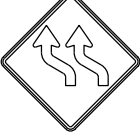

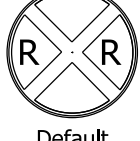

<p>5FL</p>  <p>TRAFFIC SIGNAL HEAD, 5 FACE, 12" : RED, AMBER, GREEN, LT. AMBER ARROW, LT. GREEN ARROW</p>	<p>5FR</p>  <p>TRAFFIC SIGNAL HEAD, 5 FACE, 12" : RED, AMBER, GREEN, RT. AMBER ARROW, RT. GREEN ARROW</p>	<p>OP3FL</p>  <p>TRAFFIC SIGNAL HEAD, OPTICALLY PROGRAMMED, 3 FACE, 12" : RED, LT. AMBER ARROW, LT. GREEN ARROW</p>	<p>OP3FR</p>  <p>TRAFFIC SIGNAL HEAD, OPTICALLY PROGRAMMED, 3 FACE, 12" : RED, RT. AMBER ARROW, RT. GREEN ARROW</p>
<p>OP4FL</p>  <p>TRAFFIC SIGNAL HEAD, OPTICALLY PROGRAMMED, 4 FACE, 12" : RED, AMBER, GREEN, LT. GREEN ARROW</p>	<p>OP4FR</p>  <p>TRAFFIC SIGNAL HEAD, OPTICALLY PROGRAMMED, 4 FACE, 12" : RED, AMBER, GREEN, RT. GREEN ARROW</p>	<p>OP5FL</p>  <p>TRAFFIC SIGNAL HEAD, OPTICALLY PROGRAMMED, 5 FACE, 12" : RED, AMBER, GREEN, LT. AMBER ARROW, LT. GREEN ARROW</p>	<p>OP5FR</p>  <p>TRAFFIC SIGNAL HEAD, OPTICALLY PROGRAMMED, 5 FACE, 12" : RED, AMBER, GREEN, RT. AMBER ARROW, RT. GREEN ARROW</p>
<p>E3L</p>  <p>EX. TRAFFIC SIGNAL HEAD, 3 FACE, "12" : RED, LT. AMBER ARROW, LT. GREEN ARROW</p>	<p>E3R</p>  <p>EX. TRAFFIC SIGNAL HEAD, 3 FACE, 12" : RED, RT. AMBER ARROW, RT. GREEN ARROW</p>	<p>E4L</p>  <p>EX. TRAFFIC SIGNAL HEAD, 4 FACE, 12" : RED, AMBER, GREEN, LT. GREEN ARROW</p>	<p>E4R</p>  <p>EX. TRAFFIC SIGNAL HEAD, 4 FACE, 12" : RED, AMBER, GREEN, RT. GREEN ARROW</p>
<p>E5L</p>  <p>EX. TRAFFIC SIGNAL HEAD, 5 FACE, 12" : RED, AMBER, GREEN, LT. AMBER ARROW, LT. GREEN ARROW</p>	<p>E5R</p>  <p>EX. TRAFFIC SIGNAL HEAD, 5 FACE, 12" : RED, AMBER, GREEN, RT. AMBER ARROW, RT. GREEN ARROW</p>	<p>EOP3L</p>  <p>EX. TRAFFIC SIGNAL HEAD, OPTICALLY PROGRAMMED, 3 FACE, 12" : RED, LT. AMBER ARROW, LT. GREEN ARROW</p>	<p>EOP3R</p>  <p>EX. TRAFFIC SIGNAL HEAD, OPTICALLY PROGRAMMED, 3 FACE, 12" : RED, RT. AMBER ARROW, RT. GREEN ARROW</p>
<p>EOP4L</p>  <p>EX. TRAFFIC SIGNAL HEAD, OPTICALLY PROGRAMMED, 4 FACE, 12" : RED, AMBER, GREEN, LT. GREEN ARROW</p>	<p>EOP4R</p>  <p>EX. TRAFFIC SIGNAL HEAD, OPTICALLY PROGRAMMED, 4 FACE, 12" : RED, AMBER, GREEN, RT. GREEN ARROW</p>	<p>EOP5L</p>  <p>EX. TRAFFIC SIGNAL HEAD, OPTICALLY PROGRAMMED, 5 FACE, 12" : RED, AMBER, GREEN, LT. AMBER ARROW, LT. GREEN ARROW</p>	<p>EOP5R</p>  <p>EX. TRAFFIC SIGNAL HEAD, OPTICALLY PROGRAMMED, 5 FACE, 12" : RED, AMBER, GREEN, RT. AMBER ARROW, RT. GREEN ARROW</p>
<p>EIFR</p>  <p>EX. TRAFFIC SIGNAL HEAD, 1 FACE 12" RED</p>	<p>MAG</p>  <p>MAGNETOMETER</p>	<p>MICRO</p>  <p>MICROLOOP</p>	<p>EMAG</p>  <p>EX. MAGNETOMETER</p>
<p>EMICRO</p>  <p>EX. MICROLOOP</p>	<p>ROWMKR</p>  <p>RIGHT OF WAY MARKER</p>	<p>EPRLOOP</p>  <p>PREFORMED LOOP</p>	<p>PRLLOOP</p>  <p>EX. PREFORMED LOOP</p>
<p>RAS</p>  <p>RADIO ANTENNAE (SPHERICAL POLARIZATION)</p>	<p>RAV</p>  <p>RADIO ANTENNAE (VERTICAL POLARIZATION)</p>	<p>RAH</p>  <p>RADIO ANTENNAE (HORIZONTAL POLARIZATION)</p>	<p>LEGEND</p> <hr/> <p>LEGEND</p>

Cell Library: IN_SignalsLegend.cel





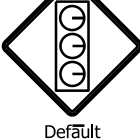
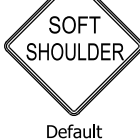

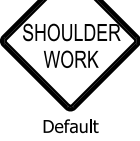
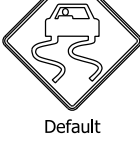
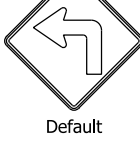
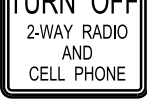











CANT -S SIGNAL CANTILEVER STRUCTURE & FOUNDATION	SSP24 24 24' STEEL STRAIN POLE & FOUNDATION		





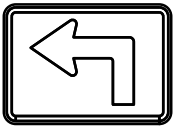

<p><i>RI2-1</i></p>  <p>Default</p>	<p><i>XG20-1</i></p>  <p>Default</p>	<p><i>XG20-2</i></p>  <p>Default</p>	<p><i>G20-4</i></p>  <p>Default</p>
<p><i>G20-2</i></p>  <p>Default</p>	<p><i>M4-9R</i></p>  <p>Default</p>	<p><i>XM4-9L</i></p>  <p>Default</p>	<p><i>W13-1P</i></p>  <p>Default</p>
<p><i>XW20-1</i></p>  <p>Default</p>	<p><i>XW20-2</i></p>  <p>Default</p>	<p><i>XW20-3</i></p>  <p>Default</p>	<p><i>XW20-7A</i></p>  <p>Default</p>
<p><i>XW21-1-A</i></p>  <p>Default</p>	<p><i>XW21-2</i></p>  <p>Default</p>	<p><i>XW21-3</i></p>  <p>Default</p>	<p><i>W21-4</i></p>  <p>Default</p>
<p><i>XW21-6</i></p>  <p>Default</p>	<p><i>XW103-1</i></p>  <p>Default</p>	<p><i>XW3-4S</i></p>  <p>Default</p>	<p><i>XW109-1</i></p>  <p>Default</p>
<p><i>XW20-1A</i></p>  <p>Default</p>	<p><i>E5-2A</i></p>  <p>Default</p>	<p><i>E5-2</i></p>  <p>Default</p>	<p><i>1500FT</i></p>  <p>Default</p>
<p><i>XW8-2</i></p>  <p>Default</p>	<p><i>W3-3A</i></p>  <p>Default</p>	<p><i>W4-2R</i></p>  <p>Default</p>	<p><i>W4-2L</i></p>  <p>Default</p>
<p><i>W6-2A</i></p>  <p>Default</p>	<p><i>XW6-3</i></p>  <p>Default</p>	<p><i>XW8-1</i></p>  <p>Default</p>	<p><i>XW8-6</i></p>  <p>Default</p>

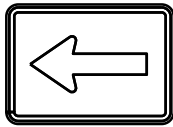
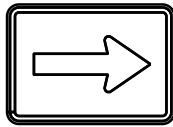
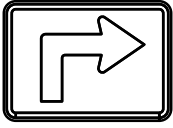
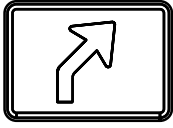
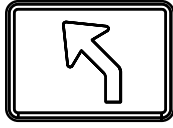
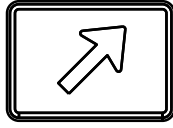
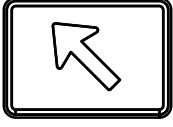
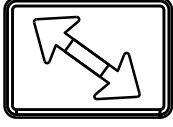
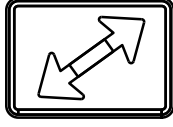
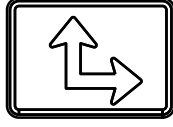
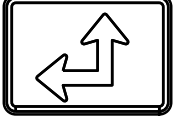
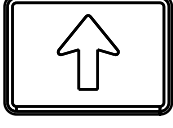
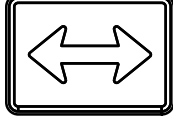
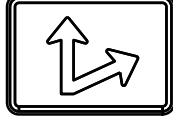

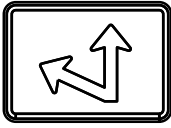



<p>WI-2L</p>  <p>Default</p>	<p>R3-9B</p>  <p>Default</p>	<p>WI-2R</p>  <p>Default</p>	<p>WI2-1</p>  <p>Default</p>
<p>W6-1</p>  <p>Default</p>	<p>XW6-2A-A</p>  <p>Default</p>	<p>W6-1A</p>  <p>Default</p>	<p>R5-1</p>  <p>Default</p>
<p>R4-1</p>  <p>Default</p>	<p>WI-7</p>  <p>Default</p>	<p>WI-6L</p>  <p>Default</p>	<p>WI-6R</p>  <p>Default</p>
<p>MI-2</p>  <p>Default</p>	<p>MI-1</p>  <p>Default</p>	<p>R4-8</p>  <p>Default</p>	<p>R4-8A</p>  <p>Default</p>
<p>R4-7</p>  <p>Default</p>	<p>R4-7A</p>  <p>Default</p>	<p>WI2-2</p>  <p>Default</p>	<p>WI2-2A</p>  <p>Default</p>
<p>W9-1</p>  <p>Default</p>	<p>XW9-2L</p>  <p>Default</p>	<p>XW8-7</p>  <p>Default</p>	<p>R3-7L</p>  <p>Default</p>
<p>W8-9</p>  <p>Default</p>	<p>W4-1L</p>  <p>Default</p>	<p>W4-1R</p>  <p>Default</p>	<p>W8-12</p>  <p>Default</p>
<p>R3-2</p>  <p>Default</p>	<p>R3-1</p>  <p>Default</p>	<p>R3-3</p>  <p>Default</p>	<p>R3-4</p>  <p>Default</p>

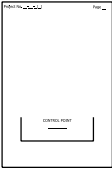

<p><i>XW20-4</i></p>  <p>Default</p>	<p><i>W5-3</i></p>  <p>Default</p>	<p><i>R6-1L</i></p>  <p>Default</p>	<p><i>R6-1R</i></p>  <p>Default</p>
<p><i>XW8-3</i></p>  <p>Default</p>	<p><i>R4-2</i></p>  <p>Default</p>	<p><i>XW4-2R</i></p>  <p>Default</p>	<p><i>R11-2</i></p>  <p>Default</p>
<p><i>R11-3A</i></p>  <p>Default</p>	<p><i>W1-4L</i></p>  <p>Default</p>	<p><i>W1-4R</i></p>  <p>Default</p>	<p><i>R11-4</i></p>  <p>Default</p>
<p><i>W1-4BL</i></p>  <p>Default</p>	<p><i>W1-4BR</i></p>  <p>Default</p>	<p><i>XW20-5R</i></p>  <p>Default</p>	<p><i>R3-7R</i></p>  <p>Default</p>
<p><i>W5-1</i></p>  <p>Default</p>	<p><i>W10-1</i></p>  <p>Default</p>	<p><i>W1-3L</i></p>  <p>Default</p>	<p><i>W1-3R</i></p>  <p>Default</p>
<p><i>XW21-4</i></p>  <p>Default</p>	<p><i>G20-1</i></p>  <p>Default</p>	<p><i>W3-1A</i></p>  <p>Default</p>	<p><i>SI-1</i></p>  <p>Default</p>
<p><i>R2-1</i></p>  <p>Default</p>	<p><i>W3-3</i></p>  <p>Default</p>	<p><i>XW8-4</i></p>  <p>Default</p>	<p><i>RI-1</i></p>  <p>Default</p>
<p><i>XW21-5-A</i></p>  <p>Default</p>	<p><i>W8-5</i></p>  <p>Default</p>	<p><i>W1-1L</i></p>  <p>Default</p>	<p><i>W22-2</i></p>  <p>Default</p>

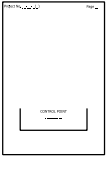

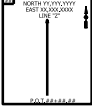
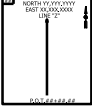



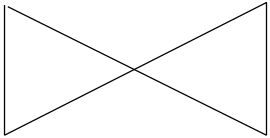
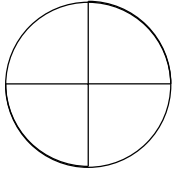
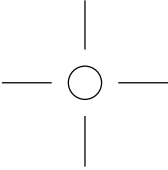
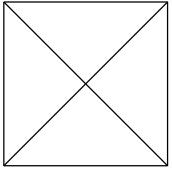
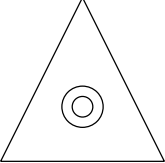
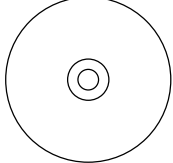
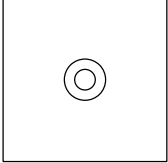
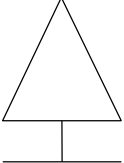
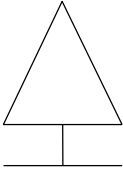
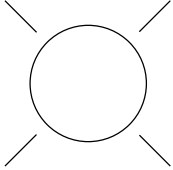
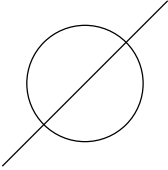
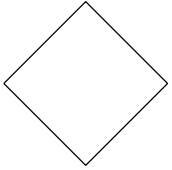
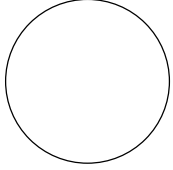
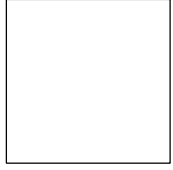
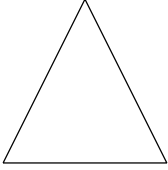
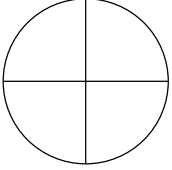
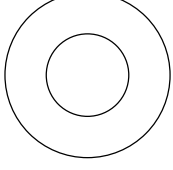
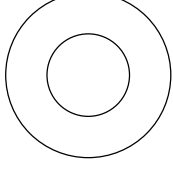
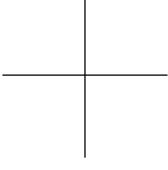
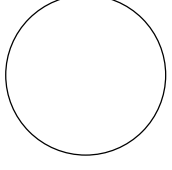
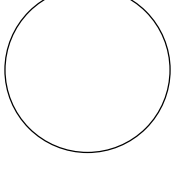
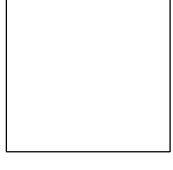
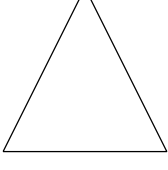
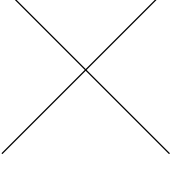









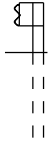

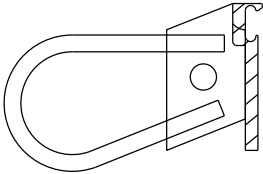
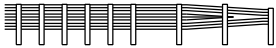

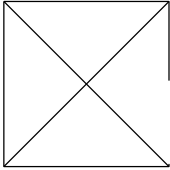
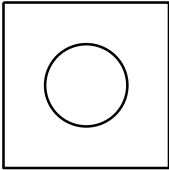
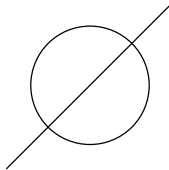

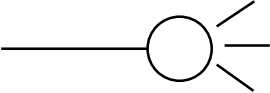
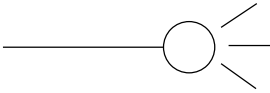
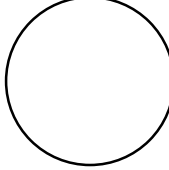
<p><i>RI-2A</i></p> <p>Default</p>	<p><i>WI-IR</i></p> <p>Default</p>	<p><i>W8-11</i></p> <p>Default</p>	<p><i>MI-4</i></p> <p>Default</p>
<p><i>W16-13P</i></p> <p>Default</p>	<p><i>R5-1A</i></p> <p>Default</p>	<p><i>W16-2P</i></p> <p>Default</p>	<p><i>W16-3A</i></p> <p>Default</p>
<p><i>XW3-2</i></p> <p>Default</p>	<p><i>RI-2</i></p> <p>Default</p>	<p><i>W3-1</i></p> <p>Default</p>	<p><i>R3-9A</i></p> <p>Default</p>
<p><i>E5-3</i></p> <p>Default</p>	<p><i>XW20-5L</i></p> <p>Default</p>	<p><i>XM4-8</i></p> <p>Default</p>	<p><i>XM4-9R</i></p> <p>Default</p>
<p><i>XW20-3-500FT</i></p> <p>Default</p>	<p><i>XW20-3-1000FT</i></p> <p>Default</p>	<p><i>XW20-2-500FT</i></p> <p>Default</p>	<p><i>XW20-5-1000FT</i></p> <p>Default</p>
<p><i>XW8-8</i></p> <p>Default</p>	<p><i>R11-73B</i></p> <p>Default</p>	<p><i>XW2-6B-B</i></p> <p>Default</p>	<p><i>XW2-6-A</i></p> <p>Default</p>
<p><i>W16-9P</i></p> <p>Default</p>	<p><i>W13-4P</i></p> <p>Default</p>	<p><i>XW21-8A</i></p> <p>Default</p>	<p><i>M4-9L</i></p> <p>Default</p>
<p><i>M4-8A</i></p> <p>Default</p>	<p><i>XW5-4</i></p> <p>Default</p>	<p><i>XW20-3G</i></p> <p>Default</p>	<p><i>XG20-5</i></p> <p>Default</p>



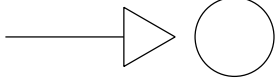



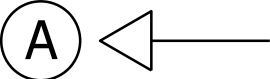

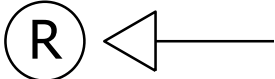

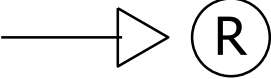
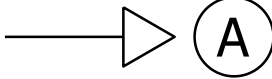

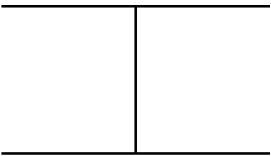
<p><i>XW9-2R</i></p>  <p>Default</p>	<p><i>R6-2R</i></p>  <p>Default</p>	<p><i>R6-2L</i></p>  <p>Default</p>	<p><i>S4-4P</i></p>  <p>Default</p>
<p><i>XW2-6A-B</i></p>  <p>Default</p>	<p><i>XW3-5A</i></p>  <p>Default</p>	<p><i>XW2I-7</i></p>  <p>Default</p>	<p><i>W2I-8B</i></p>  <p>Default</p>
<p><i>XW106-2-A</i></p>  <p>Default</p>	<p><i>XW106-1-A</i></p>  <p>Default</p>	<p><i>XW105-1-A</i></p>  <p>Default</p>	<p><i>MI-5</i></p>  <p>Default</p>
<p><i>M3-1</i></p>  <p>Default</p>	<p><i>M3-2</i></p>  <p>Default</p>	<p><i>M3-3</i></p>  <p>Default</p>	<p><i>M4-4</i></p>  <p>Default</p>
<p><i>M5-1(L)S</i></p>  <p>Default</p>	<p><i>W8-Y8</i></p>  <p>Default</p>	<p><i>M6-1(L)S</i></p>  <p>Default</p>	<p><i>M6-1(R)S</i></p>  <p>Default</p>
<p><i>M5-1(R)S</i></p>  <p>Default</p>	<p><i>M5-2(R)S</i></p>  <p>Default</p>	<p><i>M5-2(L)S</i></p>  <p>Default</p>	<p><i>M6-2(R)S</i></p>  <p>Default</p>
<p><i>M6-2(L)S</i></p>  <p>Default</p>	<p><i>M6-5(L)S</i></p>  <p>Default</p>	<p><i>M6-5(R)S</i></p>  <p>Default</p>	<p><i>M6-6(R)S</i></p>  <p>Default</p>
<p><i>M6-6(L)S</i></p>  <p>Default</p>	<p><i>M6-3S</i></p>  <p>Default</p>	<p><i>M6-4S</i></p>  <p>Default</p>	<p><i>M6-7(R)S</i></p>  <p>Default</p>

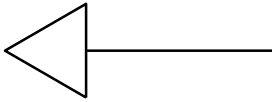
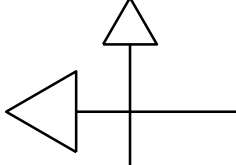
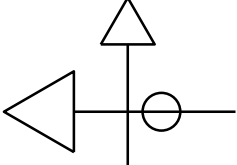
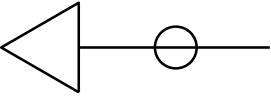
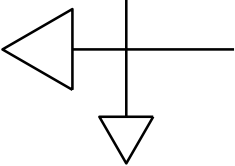
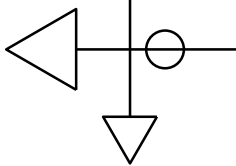

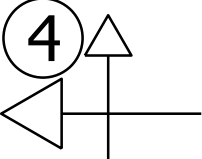
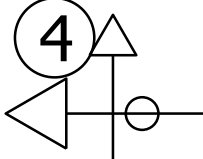
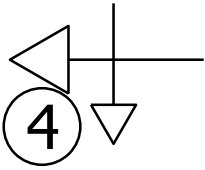
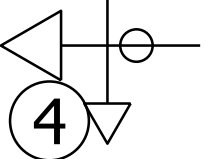

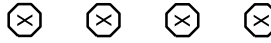
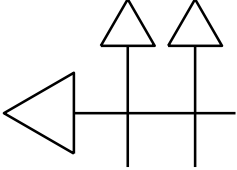
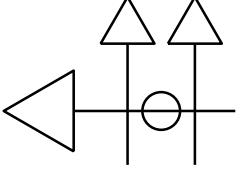
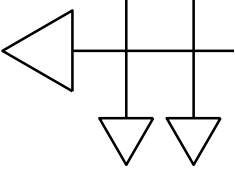
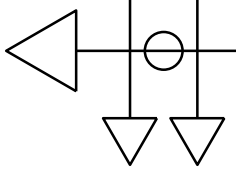
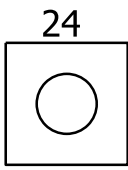

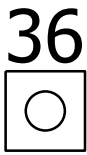

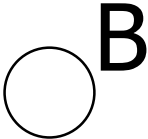
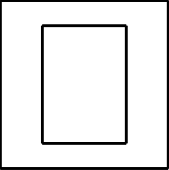
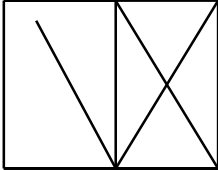
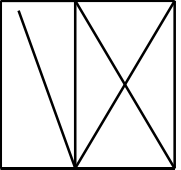

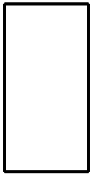
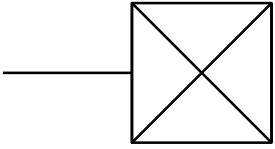
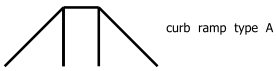
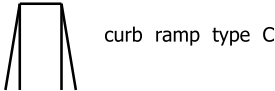
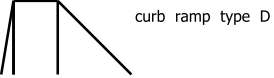
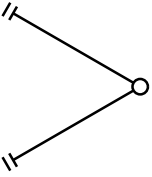
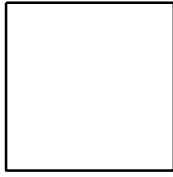
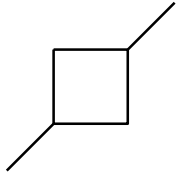

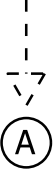
<p>M6-7(L)S</p>  <p>Default</p>	<p>ASY-ADVANCE</p>  <p>XM4-8 M3-1 M1-4 M5-1</p> <p>⊖</p>	<p>ASY-DIRECTIONAL</p>  <p>XM4-8 M3-1 M1-4 M6-1(L)</p> <p>⊖</p>	<p>ASY-CONFIRM</p>  <p>XM4-8 M3-1 M1-4 M6-3S</p> <p>⊖</p>
<p>ASY-END</p>  <p>XM4-8A M3-1 M1-4 M5-1</p> <p>⊖</p>	<p>XM4-6</p>  <p>Default</p>	<p>W14-3</p>  <p>Default</p>	







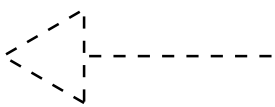
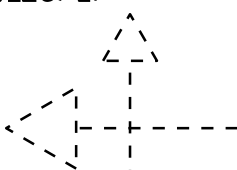
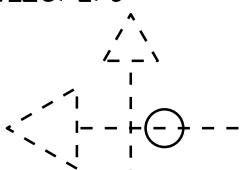
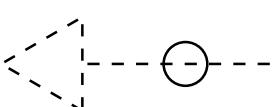
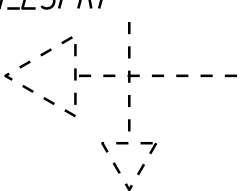
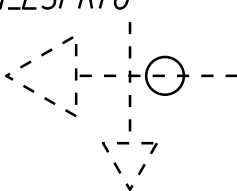

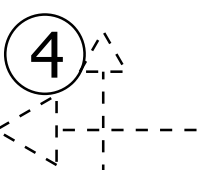
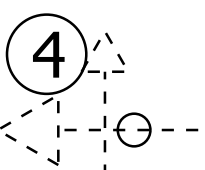
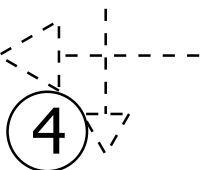
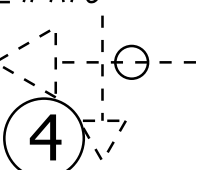
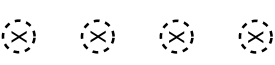
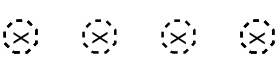
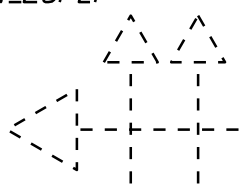
<p><i>Default</i></p>	<p><i>SV_CONTROLPT_E</i></p> 	<p><i>SV_DETAIL_E</i></p> 	<p><i>SV_CONTROLPT_M</i></p> 
<p><i>SV_DETAIL_M</i></p> 	<p><i>SV_REFPTBOX_MET</i></p> 	<p><i>SV_REFPTBOX_IMP</i></p> 	<p><i>Sec Cor Ref_IMP</i></p> 
<p><i>Sec Cor Ref_MET</i></p> 			

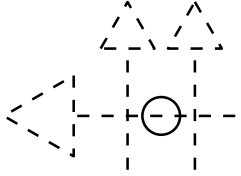
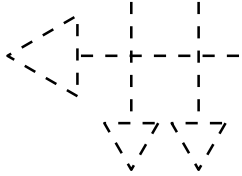
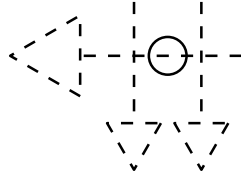
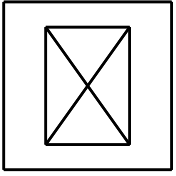
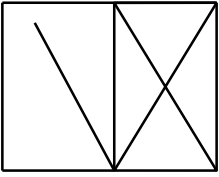
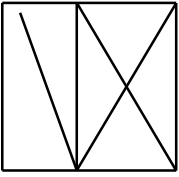
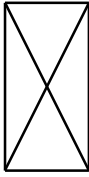
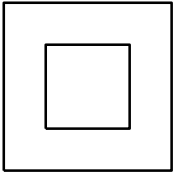
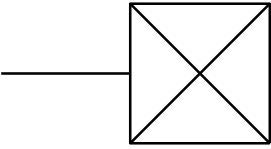
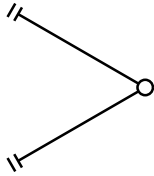
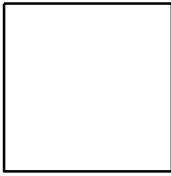
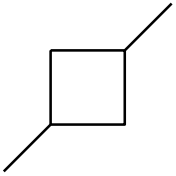
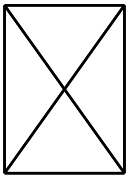
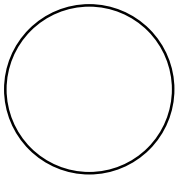

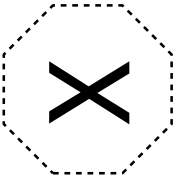

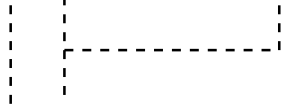
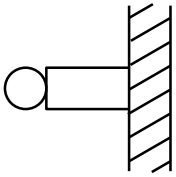
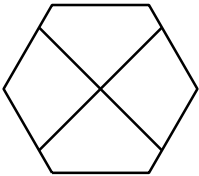
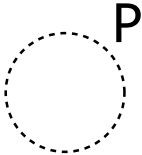
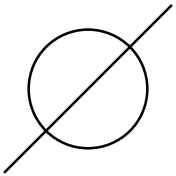

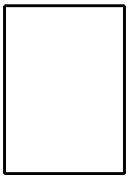
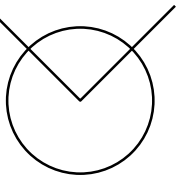
<p>_A</p> 	<p>MnMnt</p> 	<p>_B</p> 	<p>INDOT</p> 
<p>_C</p> 	<p>_D</p> 	<p>_E</p> 	<p>_F</p> 
<p>_G</p> 	<p>_H</p> 	<p>_I</p> 	<p>_J</p> 
<p>_K</p> 	<p>_L</p> 	<p>RRS</p> 	<p>_M</p> 
<p>Pipe</p> 	<p>MAG_N</p> 	<p>_N</p> 	<p>_O</p> 
<p>CALC</p> 	<p>Stone</p> 	<p>_P</p> 	<p>_Q</p> 
<p>NORTH</p> 			

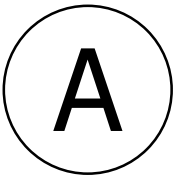
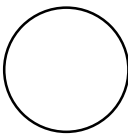
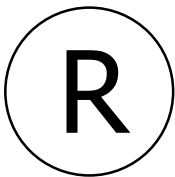
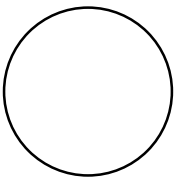
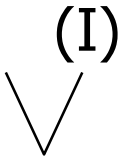

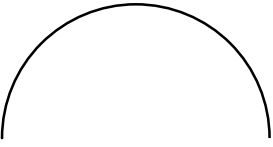
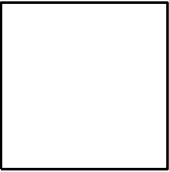
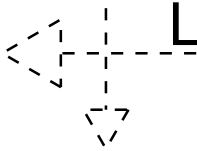
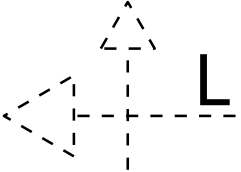
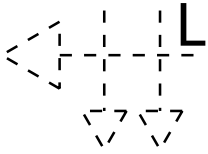
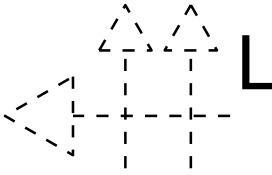
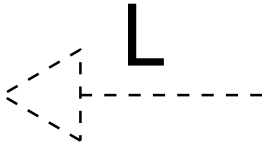
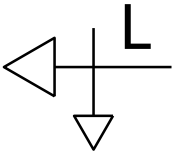
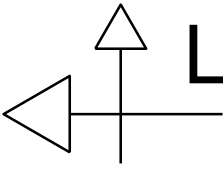
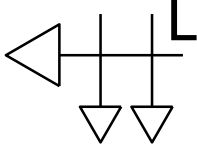
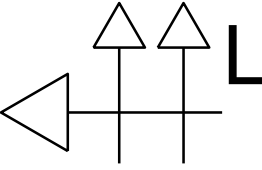
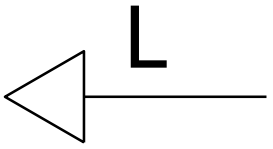
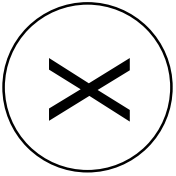
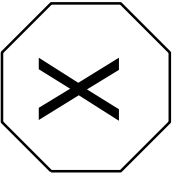
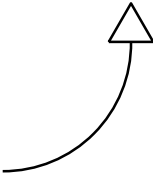



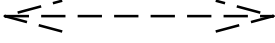
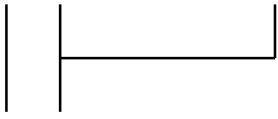
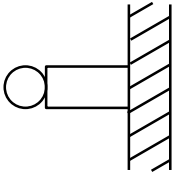
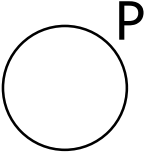
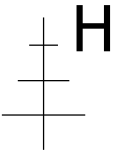
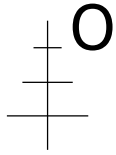
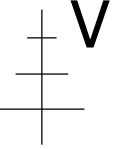
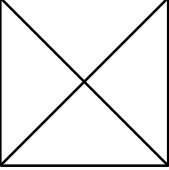
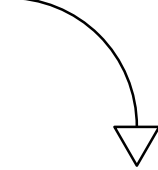
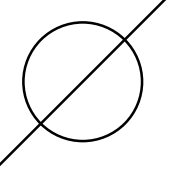
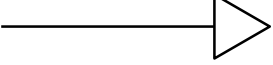

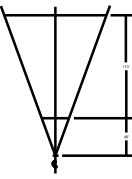
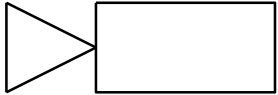

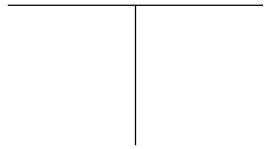
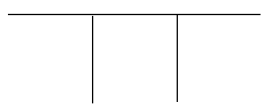
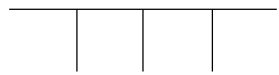
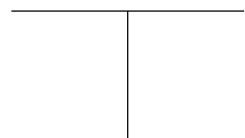
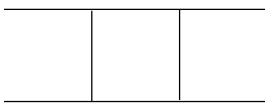

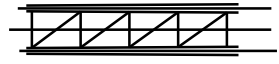
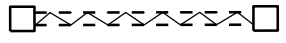
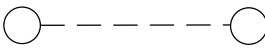
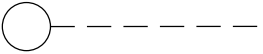
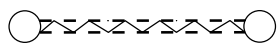
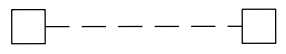
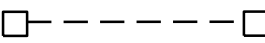
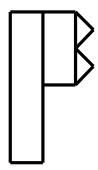
<p><i>Default</i></p>	<p><i>BR_33W141</i></p>  <p>33 WF 141</p>	<p><i>BR_AL3</i></p>  <p>Aluminum Railing Type 3</p>	<p><i>BR_AL5</i></p>  <p>Aluminum Type 5</p>
<p><i>BR_AL6</i></p>  <p>Aluminum Type 6</p>	<p><i>BR_CONCRI</i></p>  <p>33\" Concrete Bridge Railing</p> <p>Area = 2,5841 m² Perimeter = 7,6592 ft</p>	<p><i>BR_CONCRL</i></p>  <p>45\" Concrete Bridge Railing</p> <p>Area = 3,2899 m² Perimeter = 8,5792 ft</p>	<p><i>BR_GRAIL</i></p>  <p>Whitem Guardrail Section</p>
<p><i>BR_PSI</i></p>  <p>PS-1 Parapet</p> <p>Area = 1,6597 m² Perimeter = 5,9560 ft</p>	<p><i>BR_SST</i></p> 	<p><i>BR_TGBI</i></p> 	<p><i>BR_TGBPLN</i></p> 
<p><i>EA_ECAB2C</i></p> 	<p><i>EA_ESSP</i></p> 	<p><i>EA_EUTILP</i></p> 	<p><i>NORTH</i></p> 
<p><i>EA_SPLUM</i></p> 	<p><i>EA_WPLUM</i></p> 	<p><i>DS_CIRC_E</i></p> 	<p><i>SEAL_E</i></p> 
<p><i>SEAL2_E</i></p> 	<p><i>SEAL_M</i></p> 	<p><i>SEAL2_M</i></p> 	<p><i>SN_IF</i></p> 
<p><i>SN_IFIP</i></p> 	<p><i>SN_IF2P</i></p> 	<p><i>SN_IF3P</i></p> 	<p><i>SN_IFADN</i></p> 
<p><i>SN_IFALT</i></p> 	<p><i>SN_IFAUP</i></p> 	<p><i>SN_IFRDN</i></p> 	<p><i>SN_IFRLT</i></p> 

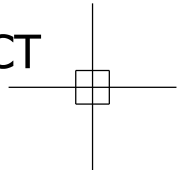



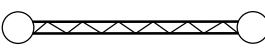
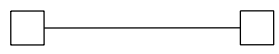
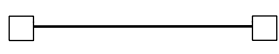



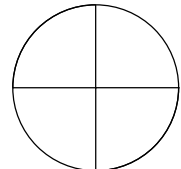
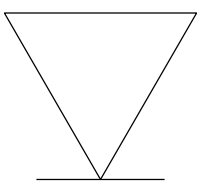
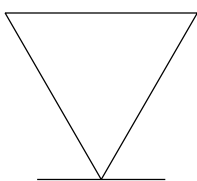
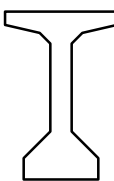
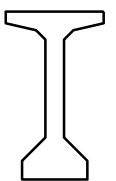

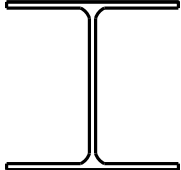







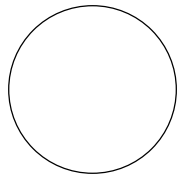

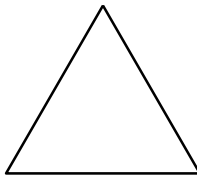

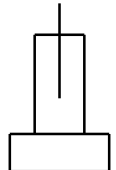

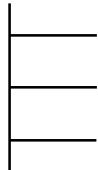

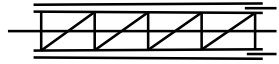
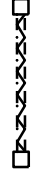
<p>SN_IFRRT</p> 	<p>SN_IFRT</p> 	<p>SN_IFRUP</p> 	<p>SN_2FIP</p> 
<p>SN_2F2P</p> 	<p>SN_3F</p> 	<p>SN_3FLT</p> 	<p>SN_3FLT0P</p> 
<p>SN_3F0</p> 	<p>SN_3FRT</p> 	<p>SN_3FRT0P</p> 	<p>SN_3L00PCIR</p> 
<p>SN_3L00POCT</p> 	<p>SN_4FLT</p> 	<p>SN_4FLT0P</p> 	<p>SN_4FRT</p> 
<p>SN_4FRT0P</p> 	<p>SN_4L00PCIR</p> 	<p>SN_4L00POCT</p> 	<p>SN_5FLT</p> 
<p>SN_5FLT0P</p> 	<p>SN_5FRT</p> 	<p>SN_5FRT0P</p> 	<p>SN_24SSP</p> 
<p>SN_30ESSP</p> 	<p>SN_30SSP</p> 	<p>SN_36ESSP</p> 	<p>SN_36SSP</p> 
<p>SN_BRIDLE</p> 	<p>SN_CABGA</p> 	<p>SN_CABMM</p> 	<p>SN_CABPP</p> 

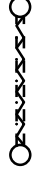

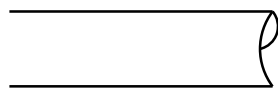
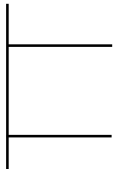





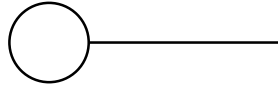

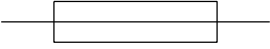
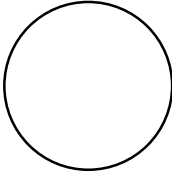

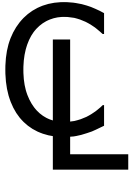
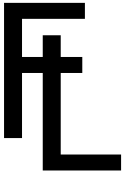

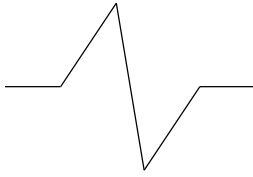

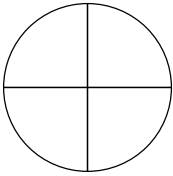

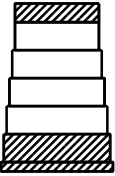
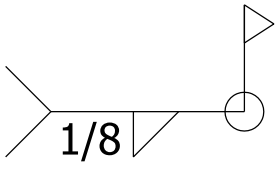



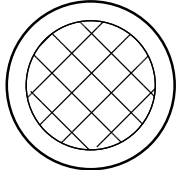
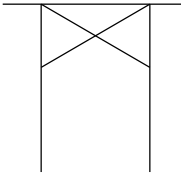
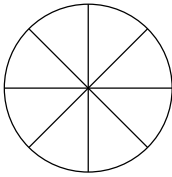



<p>SN_CABRR</p> 	<p>SN_CANT</p> 	<p>SN_CRTA</p> 	<p>SN_CRTC</p> 
<p>SN_CRTD</p> 	<p>SN_DG</p> 	<p>SN_DH</p> 	<p>SN_DISCO</p> 
<p>SN{EIF</p> 	<p>SN{EIFADN</p> 	<p>SN{EIFALT</p> 	<p>SN{EIFAUP</p> 
<p>SN{EIFRDN</p> 	<p>SN{EIFRLT</p> 	<p>SN{EIFRRT</p> 	<p>SN{EIFRT</p> 
<p>SN{EIFRUP</p> 	<p>SN_E3F</p> 	<p>SN_E3FLT</p> 	<p>SN_E3FLT0</p> 
<p>SN_E3FOP</p> 	<p>SN_E3FRT</p> 	<p>SN_E3FRTO</p> 	<p>SN_E3L00PCIR</p> 
<p>SN_E3L00POCT</p> 	<p>SN_E4FLT</p> 	<p>SN_E4FLTO</p> 	<p>SN_E4FRT</p> 
<p>SN_E4FRTO</p> 	<p>SN_E4L00PCIR</p> 	<p>SN_E4L00POCT</p> 	<p>SN_E5FLT</p> 











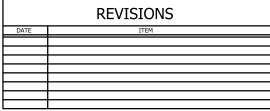





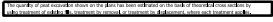
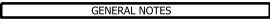

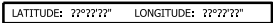
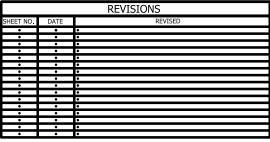
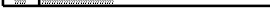

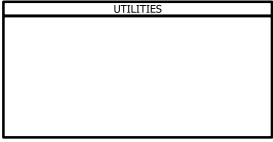
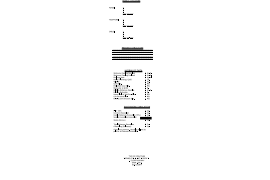
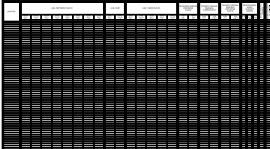
SN_E5FLT0 	SN_E5FRT 	SN_E5FRTO 	SN_ECABGA 
SN_ECABMM 	SN_ECABPP 	SN_ECABRR 	SN_ECABUT 
SN_ECANT 	SN_EDG 	SN_EDH 	SN_EDISCO 
SN_EFCAB 	SN_EHH 	SN_ELOOPCIR 	SN_ELOOPOCT 
SN_EMAG 	SN_EMLOOP 	SN_EPEDHD 	SN_EPEDPU 
SN_EPEDST 	SN_EPLOOP 	SN_EUTILP 	SN_EVIDEO 
SN_FCAB 	SN_FIREHY 	SN_HEAD4 	SN_HEADA 
SN_HEADO 	SN_HEADR 	SN_HH 	SN_INCEPT 

<p>SN_INLETC</p> 	<p>SN_INLETD</p> 	<p>SN_LEDEID</p> 	<p>SN_LEDEIU</p> 
<p>SN_LEDE2D</p> 	<p>SN_LEDE2U</p> 	<p>SN_LEDELT</p> 	<p>SN_LEDPID</p> 
<p>SN_LEDPIU</p> 	<p>SN_LEDP2D</p> 	<p>SN_LEDP2U</p> 	<p>SN_LEDPLT</p> 
<p>SN_LOOPCIR</p> 	<p>SN_LOOPOCT</p> 	<p>SN_LT</p> 	<p>SN_MAG</p> 
<p>SN_MLOOP</p> 	<p>SN_NCS</p> 	<p>SN_PED</p> 	<p>SN_PEDHD</p> 
<p>SN_PEDPU</p> 	<p>SN_PLOOP</p> 	<p>SN_RAH</p> 	<p>SN_RAS</p> 
<p>SN_RAV</p> 	<p>SN_ROW</p> 	<p>SN_RT</p> 	<p>SN_STUBP</p> 
<p>SN_THRU</p> 	<p>SN_TREE</p> 	<p>SN_VC_ENG</p> 	<p>SN_VIDEO</p> 

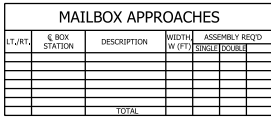

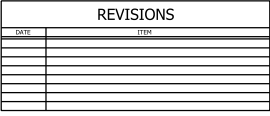
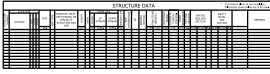
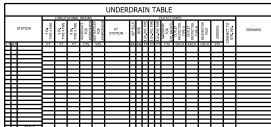
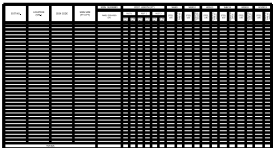

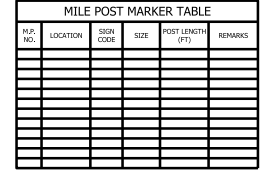



























<p><i>SG_IFIP</i></p> 	<p><i>SG_IF2P</i></p> 	<p><i>SG_IF3P</i></p> 	<p><i>SG_2FIP</i></p> 
<p><i>SG_2F2P</i></p> 	<p><i>SG_CANTUR</i></p> 	<p><i>SG_CT</i></p> 	<p><i>SG_EBOX</i></p> 
<p><i>SG_ECABSP</i></p> 	<p><i>SG_ECANT</i></p> 	<p><i>SG_ECORD</i></p> 	<p><i>SG_EMONO</i></p> 
<p><i>SG_ETWTUB</i></p> 	<p><i>SG_GDRS</i></p> 	<p><i>SG_GUARD</i></p> 	<p><i>SG_JCTB</i></p> <p>JCT</p> 
<p><i>SG_OBJ3</i></p> 	<p><i>SG_PBOX</i></p> 	<p><i>SG_PCANT</i></p> 	<p><i>SG_PCASBS</i></p> 
<p><i>SG_PCORD</i></p> 	<p><i>SG_PMONO</i></p> 	<p><i>SG_PTWTUB</i></p> 	<p><i>SG_TYPEI</i></p> 
<p><i>SG_TYPEIV</i></p> 	<p><i>SG_TYPEV</i></p> 	<p><i>SG_TYPEVI</i></p> 	<p><i>DS_BLSYM</i></p> 
<p><i>DS_GWL24</i></p> 	<p><i>DS_GWLAC</i></p> 	<p><i>DS_ASHT05_E</i></p> 	<p><i>DS_ASHT06_E</i></p> 

DS_HP310X79_E 	DS_TBC_E 	DS_TGBLT_E 	DS_TGBRT_E 
DS_TRKRAIL_E 	DS_WBC_E 	DS_WGBLT_E 	DS_WGBRT_E 
SV_FBCIRC_E 	SV_REFBOXARROW_E 	SV_SECMAR_E 	SG_Box Truss 
SG_Box Truss Foundation 	SG_Box Truss Pole 	SG_Bridge Bracket Symbol 	SG_Cantilever Foundation 
SG_Cantilever Pole 	SG_Double Arm Cantilever 	SG_ECABSP-2 	SG_ECABSP-2 
SG_ECANT-2 	SG_ETCORD 	SG_GM Panel Foundation 	SG_GM Panel Foundation 24" 
SG_Ground Mount Panel Sign Symbol 	SG_Sign Mount Sheet Sign Symbol 	SG_Sign Panel 	SG_PBOX-2 
SG_PCABSP 	SG_PCANT-2 	SG_PTCORD 	SG_Sign Cantilever Symbol 





























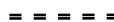

<p><i>DS_PROLOC_E</i></p> 	<p><i>DS_CIRC_E_FILL</i></p> 	<p><i>ST_PROPLINE</i></p> 	<p><i>ST_CENTERLINE</i></p> 
<p><i>ST_FLOWLINE</i></p> 	<p><i>ST_BOUNDLINE</i></p> 	<p><i>RE_BREAK</i></p> 	<p><i>ST_TERMAREA</i></p> 
<p><i>RE_SECTCOR</i></p> 	<p><i>TR_Tubular Marker</i></p> 	<p><i>TR_Barrel</i></p> 	<p><i>BR_Fillet Weld</i></p> 
<p><i>BR_Joint Type A</i></p> 	<p><i>BR_Pipe End</i></p> 	<p><i>RD_Temp Conc Barrier</i></p> 	<p><i>RD_MOT Barrel</i></p> 
<p><i>SN_ROADCLOSURE ASSY</i></p> 	<p><i>SN_CONSTWARNLGT</i></p> 	<p><i>SHT W STAMP LANDSCAPE</i></p> 	<p><i>ABET W STAMP PORTRAIT</i></p> 
<p><i>811Logo_Dsize</i></p> 	<p><i>811Logo_Ltrsize</i></p> 		
			
			

<p>DS_BRIND</p> 	<p>DS_BRSR</p> 	<p>DS_FHWA</p> 	<p>DS_GN0009</p> 
<p>DS_GN0012</p> 	<p>DS_GN0013</p> 	<p>DS_GN0014</p> 	<p>DS_GN0018</p> 
<p>DS_GN</p> 	<p>DS_INDEX</p> 	<p>DS_INDRW</p> 	<p>DS_LATLONG</p> 
<p>DS_REVS</p> 	<p>DS_RWINDBLNK</p> 	<p>DS_TICKS</p> 	<p>DS_UTIL</p> 
<p>DS_LINFO</p> 	<p>DS_PVMTTBL</p> 	<p>DS_PMATTBL1</p> 	<p>DS_PMATTBL2</p> 
<p>DS_PQATBL</p> 	<p>DS_GRAILSUM</p> 	<p>DS_MAILAPP</p> 	<p>DS_PSDRRD</p> 
<p>DS_RDSR</p> 	<p>DS_STRDATA</p> 	<p>DS_UDTBL</p> 	<p>DS_PANLSNTBL</p> 
<p>DS_SHTSNTBL</p> 	<p>DS_MPMRKRTBL</p> 	<p>DS_BRSQ</p> 	<p>DS_BRSQ</p> 































Cell Library: IN_TablesLegendsNotesTraffic.cel













































<p>LG_BA</p>  <p>XXXXXXXXXXXXXXXX Roadway Luminaire on Breakaway Base (Breakaway Transformer Base, Breakaway Couplings) XXXXX</p>	<p>LG_CABMAR</p>  <p>Cable Marker: Exact Location and Arrow Direction to be Determined after Cable Duct Installation</p>	<p>LG_CO</p>  <p>XXXXXXXXXXXX Roadway Luminaire Having Output Characteristics Equivalent to XXXXXX</p>	<p>LG_DUCT IN CONDUIT</p>  <p>4-IC No. 4 Copper Conductor in Plastic Duct in 2" Galvanized Steel Conduit</p>
<p>LG_DUCT IN TRENCH</p>  <p>4-IC No. 4 Copper Conductor in Plastic Duct in Trench</p>	<p>LG_EX BA</p>  <p>Existing XXXXXXXX Roadway Luminaire on Breakaway Base (Breakaway Transformer Base, Breakaway Couplings) XXX</p>	<p>LG_EX COII</p>  <p>Existing XXXXXXXX Roadway Luminaire Having Output Characteristics Equivalent to XXXXXX</p>	<p>LG_EX CABMAR</p>  <p>Existing Cable Marker</p>
<p>LG_EX DUCT IN CONDUIT</p>  <p>Existing 4-IC No. 4 Copper Conductor in Plastic Duct in 2" Galvanized Steel Conduit</p>	<p>TLG_EX DUCT IN TRENCH</p>  <p>Existing 4-IC No. 4 Copper Conductor in Plastic Duct in Trench</p>	<p>HLG_EX HH</p>  <p>Existing Lighting Handhole</p>	<p>LG_EX NBA</p>  <p>XXXXXXXXXXXXX Roadway Luminaire on Non-Breakaway Base (Anchor Base, Steel Transformer Base) XXXXXX</p>
<p>LG_EX NBA400</p>  <p>Existing XXXXXXXXXX Roadway Luminaire on Breakaway Base (Breakaway Transformer Base, Breakaway Couplings) XXXXX</p>	<p>LG_EX SVPT I</p>  <p>Existing Lighting Service Point I</p>	<p>LG_EX SVPT 2</p>  <p>Existing Lighting Service Point II</p>	<p>LG_HH</p>  <p>Lighting Handhole</p>
<p>LG_NBA</p>  <p>XXXXXXXXXXXXX Roadway Luminaire on Non-Breakaway Base (Anchor Base, Steel Transformer Base) XXXXXX</p>	<p>LG_SVPT I</p>  <p>Lighting Service Point I</p>	<p>LG_SVPT 2</p>  <p>Lighting Service Point II</p>	<p>LG_T490</p>  <p>High Mast Lighting Unit with 4 - XXXXXXXXXX, Luminaires to be Oriented in the Direction of Arrows (Symmetric)</p>
<p>LG_T660</p>  <p>High Mast Lighting Unit with 6 - XXXXXXXXXX, Luminaires to be Oriented in the Direction of Arrows (Symmetric)</p>	<p>LG_T4180</p>  <p>High Mast Lighting Unit with 4 - XXXXXXXXXX, 2 Luminaires Oriented in the Direction of One Arrow and 2 in Opposite Direction</p>	<p>LG_T6180</p>  <p>High Mast Lighting Unit with 6 - XXXXXXXXXX, 3 Luminaires Oriented in the Direction of One Arrow and 3 in Opposite Direction</p>	<p>LG_TOW4</p>  <p>High Mast Lighting Unit with 4 - XXXXXXXX, All Luminaires Oriented in the Same Compass Direction (Asymmetric)</p>
<p>LG_TOW6</p>  <p>High Mast Lighting Unit with 6 - XXXXXXXXXX, All Luminaires Oriented in the Same Compass Direction (Asymmetric)</p>	<p>LG_UP</p>  <p>XXXXXXXXXXXXXXXXX Underpass Luminaire XXX</p>	<p>SG_IFA</p>  <p>Traffic Signal Head, 1 Face, 12" Amber</p>	<p>SG_IFR</p>  <p>Traffic Signal Head, 1 Face, 12" Red</p>
<p>SG_3F</p>  <p>Traffic Signal Head, 3 Face, 12": Red, Amber, & Green</p>	<p>SG_3FL</p>  <p>Traffic Signal Head, 3 Face, 12": Red Arrow, Amber Arrow, & Green Arrow</p>	<p>SG_3FR</p>  <p>Traffic Signal Head, 3 Face, 12": Red Arrow, Amber Arrow, & Green Arrow</p>	<p>SG_4FL</p>  <p>Traffic Signal Head, 4 Face, 12": Red Arrow, Amber Arrow, & Green Arrow</p>



Cell Library: IN_TablesLegendsNotesTraffic.cel

<p>SG_4FR</p>  <p>Traffic Signal Head, 4 Face, 12": Red Arrow, Amber Arrow, & Green Arrow</p>	<p>SG_5FL</p>  <p>Traffic Signal Head, 5 Face, 12": Red, Amber, Green, Lt. Amber Arrow, & Lt. Green Arrow</p>	<p>SG_5FR</p>  <p>Traffic Signal Head, 5 Face, 12": Red, Amber, Green, Rt. Amber Arrow, & Rt. Green Arrow</p>	<p>SG_ACCESSBOX</p>  <p>Access Box with Receiver / Processor</p>
<p>SG_BRID</p>  <p>Bridle</p>	<p>SG_CANT</p>  <p>Signal Cantilever Structure & Foundation</p>	<p>SG_CONCUR</p>  <p>Concrete Curb</p>	<p>SG_CONDUIT</p>  <p>2" Conduit</p>
<p>SG_CURCUT</p>  <p>Curb and Gutter</p>	<p>SG_DETECT</p>  <p>Signal Detector Housing</p>	<p>SG_DISCON</p>  <p>Disconnect Hanger</p>	<p>SG_EIFA</p>  <p>Ex. Traffic Signal Head, 1 Face, 12" Amber</p>
<p>SG_EIFR</p>  <p>Ex. Traffic Signal Head, 1 Face, 12" Red</p>	<p>SG_E3F</p>  <p>Ex. Traffic Signal Head, 3 Face, 12": Red, Amber, & Green</p>	<p>SG_E3L</p>  <p>Ex. Traffic Signal Head, 3 Face, 12": Red Arrow, Amber Arrow, & Green Arrow</p>	<p>SG_E3R</p>  <p>Ex. Traffic Signal Head, 3 Face, 12": Red Arrow, Amber Arrow, & Green Arrow</p>
<p>SG_E4L</p>  <p>Ex. Traffic Signal Head, 4 Face, 12": Red Arrow, Amber Arrow, & Green Arrow</p>	<p>SG_E4R</p>  <p>Ex. Traffic Signal Head, 4 Face, 12": Red Arrow, Amber Arrow, & Green Arrow</p>	<p>SG_E5L</p>  <p>Ex. Traffic Signal Head, 5 Face, 12": Red, Amber, Green, Lt. Amber Arrow, & Lt. Green Arrow</p>	<p>SG_E5R</p>  <p>Ex. Traffic Signal Head, 5 Face, 12": Red, Amber, Green, Rt. Amber Arrow, & Rt. Green Arrow</p>
<p>SG_ECAGTR</p>  <p>Ex. Curb and Gutter</p>	<p>SG_ECANT</p>  <p>Ex. Signal Cantilever Structure & Foundation</p>	<p>SG_ECTR2</p>  <p>Ex. 2" Conduit</p>	<p>SG_ECURB</p>  <p>Ex. Curb</p>
<p>SG_EDETL</p>  <p>Ex. Detection Loop, 4-Turn Series</p>	<p>SG_EDISCO</p>  <p>Ex. Disconnect Hanger</p>	<p>SG_EDTEC</p>  <p>Ex. Signal Detector Housing</p>	<p>SG_EFLAS</p>  <p>Ex. Flasher Controller and Cabinet</p>
<p>SG_EHH-I</p>  <p>Ex. Signal Handhole Type-I</p>	<p>SG_EHH-II</p>  <p>Ex. Signal Handhole Type-II</p>	<p>SG_EMAG</p>  <p>Ex. Magnetometer</p>	<p>SG EMCAB</p>  <p>Ex. Controller and Type M Cabinet on Type M Foundation</p>

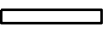
Cell Library: IN_TablesLegendsNotesTraffic.cel

<p>SG_EMICRO</p>  <p>Ex. Microloop</p>	<p>SG_EOP3F</p>  <p>Ex. Traffic Signal Head, Optically Programmed, 3 Face, 12"; Red, Amber, & Green</p>	<p>SG_EOP3L</p>  <p>Ex. Traffic Signal Head, Optically Programmed, 3 Face, Red Arrow, Amber Arrow, & Green Arrow</p>	<p>SG_EOP4L</p>  <p>Ex. Traffic Signal Head, Optically Programmed, 4 Face, 12"; Red Arrow, Amber Arrow, & Green Arrow</p>
<p>SG_EOP4R</p>  <p>Ex. Traffic Signal Head, Optically Programmed, 4 Face, 12"; Red Arrow, Amber Arrow, & Green Arrow</p>	<p>SG_EOP5L</p>  <p>Ex. Traffic Signal Head, Optically Programmed, 5 Face, 12"; Red, Amber, Green, Lt. Amber Arrow, & Lt. Green Arrow</p>	<p>SG_EOP5R</p>  <p>Ex. Traffic Signal Head, Optically Programmed, 5 Face, 12"; Red, Amber, Green, Rt. Amber Arrow, & Rt. Green Arrow</p>	<p>SG_EPICAB</p>  <p>Ex. Controller and Type P-1 Cabinet on Type P-1 Foundation</p>
<p>SG_EPAVE</p>  <p>Ex. Pavement Message Markings</p>	<p>SG_EPED</p>  <p>Ex. Pedestrian Signal Head</p>	<p>SG_EPRLOOP</p>  <p>Preformed Loop</p>	<p>SG_EPUSH</p> <p>EX. P Ex. Pedestrian Push Button & Sign</p>
<p>SG_EROW</p>  <p>Ex. Right Of Way</p>	<p>SG_ERRSCC</p>  <p>Ex. Railroad Signal Controller Cabinet</p>	<p>SG_ESIPED</p>  <p>Ex. Signal Pedestal on Type A Foundation</p>	<p>SG_ESSP24</p>  <p>Ex. 24' Steel Strain Pole & Foundation</p>
<p>SG_ESSP30</p>  <p>Ex. 30' Steel Strain Pole & Foundation</p>	<p>SG_ESSP36</p>  <p>Ex. 36' Steel Strain Pole & Foundation</p>	<p>SG_EST</p>  <p>Ex. 24" Stop Line</p>	<p>SG_EUTIL</p>  <p>Ex. Utility Cabinet</p>
<p>SG_EUTILP</p>  <p>Ex. Utility Pole</p>	<p>SG_EVVIDEO</p>  <p>Ex. Video Camera</p>	<p>SG_EWP</p>  <p>Ex. Wood Pole with Down Guys & Anchor</p>	<p>SG_EXCAB</p>  <p>Ex. Controller and Type G Cabinet on Type A Foundation</p>
<p>SG_EXFIRE</p>  <p>Ex. Fire Hydrant</p>	<p>SG_EXRAH</p>  <p>Existing Radio Antenna (Horizontal Polarization)</p>	<p>SG_EXRAS</p>  <p>Existing Radio Antenna (Spherical Polarization)</p>	<p>SG_EXRAV</p>  <p>Existing Radio Antenna (Vertical Polarization)</p>
<p>SG_GCAB</p>  <p>Controller and Type G Cabinet on Type A Foundation</p>	<p>SG_HH-I</p>  <p>Signal Handhole Type-I</p>	<p>SG_HH-II</p>  <p>Signal Handhole Type-II</p>	<p>SG_INT</p>  <p>Intercept</p>

<p>SG_LEGEND</p> <p style="text-align: center;"><u>LEGEND</u></p>	<p>SG_MAG</p> <p style="text-align: center;">MM ○ Magnetometer</p>	<p>SG_MCAB</p> <p style="text-align: center;"> Ts2 Controller and Type M Cabinet Min. 4 Phase on Type M Foundation</p>	<p>SG_MICRO</p> <p style="text-align: center;">ML ○ Microloop</p>								
<p>SG_NEMA</p> <p style="text-align: center;"> NEMA 2-Circuit Flasher and Cabinet</p>	<p>SG_OP3F</p> <p style="text-align: center;"> Traffic Signal Head, Optically Programmed, 3 Face, 12": Red, Amber, & Green</p>	<p>SG_OP3FL</p> <p style="text-align: center;"> Traffic Signal Head, Optically Programmed, 3 Face, 12": Red Arrow, Amber Arrow, & Green Arrow</p>	<p>SG_OP3FR</p> <p style="text-align: center;"> Traffic Signal Head, Optically Programmed, 3 Face, 12": Red Arrow, Amber Arrow, & Green Arrow</p>								
<p>SG_OP4FL</p> <p style="text-align: center;"> Traffic Signal Head, Optically Programmed, 4 Face, 12": Red Arrow, Amber Arrow, & Green Arrow</p>	<p>SG_OP4FR</p> <p style="text-align: center;"> Traffic Signal Head, Optically Programmed, 4 Face, 12": Red Arrow, Amber Arrow, & Green Arrow</p>	<p>SG_OP5FL</p> <p style="text-align: center;"> Traffic Signal Head, Optically Programmed, 5 Face, 12": Red, Amber, Green, Lt. Amber Arrow, & Lt. Green Arrow</p>	<p>SG_OP5FR</p> <p style="text-align: center;"> Traffic Signal Head, Optically Programmed, 5 Face, 12": Red, Amber, Green, Rt. Amber Arrow, & Rt. Green Arrow</p>								
<p>SG_PAVEME</p> <p style="text-align: center;"> Pavement Message Markings</p>	<p>SG_PEDIB</p> <p style="text-align: center;"> Pedestrian Signal Head, International Symbols, 18"</p>	<p>SG_PHASE8</p> <p style="text-align: center;">PHASE DIAGRAM</p> <table border="1" style="margin: auto;"> <tr> <td style="text-align: center;">01 </td> <td style="text-align: center;">02 </td> <td style="text-align: center;">03 </td> <td style="text-align: center;">04 </td> </tr> <tr> <td style="text-align: center;">05 </td> <td style="text-align: center;">06 </td> <td style="text-align: center;">07 </td> <td style="text-align: center;">08 </td> </tr> </table> <p style="text-align: center;">XXXXXXXXXX</p>	01 	02 	03 	04 	05 	06 	07 	08 	<p>SG_PRLLOOP</p> <p style="text-align: center;">○^P Ex. Preformed Loop</p>
01 	02 	03 	04 								
05 	06 	07 	08 								
<p>SG_PUSH</p> <p style="text-align: center;">P Pedestrian Push Button & Sign</p>	<p>SG_RAH</p> <p style="text-align: center;"> Radio Antenna (Horizontal Polarization)</p>	<p>SG_RAS</p> <p style="text-align: center;"> Radio Antenna (Spherical Polarization)</p>	<p>SG_RAV</p> <p style="text-align: center;"> Radio Antenna (Vertical Polarization)</p>								
<p>SG_REPEATER</p> <p style="text-align: center;">(R) Wireless Repeater</p>	<p>SG_ROW</p> <p style="text-align: center;">○---○ Right Of Way</p>	<p>SG_ROWMKR</p> <p style="text-align: center;">☒ Right-Of-Way Marker</p>	<p>SG_SENSOR</p> <p style="text-align: center;">SX□ Wireless Sensor</p>								
<p>SG_SIPED</p> <p style="text-align: center;"> Signal Pedestal on Type A Foundation</p>	<p>SG_SSP24</p> <p style="text-align: center;"> 24' Steel Strain Pole & Foundation</p>	<p>SG_SSP30</p> <p style="text-align: center;"> 30' Steel Strain Pole & Foundation</p>	<p>SG_SSP36</p> <p style="text-align: center;"> 36' Steel Strain Pole & Foundation</p>								
<p>SG_STP</p> <p style="text-align: center;"> 24" Stop Line</p>	<p>SG_STUB</p> <p style="text-align: center;"> Stub Pole</p>	<p>SG_TAGTAB</p> <table border="1" style="margin: auto;"> <thead> <tr> <th colspan="2">LOOP TAGGING TABLE</th> </tr> <tr> <th>LANE</th> <th>TAG - NUMBER</th> </tr> </thead> <tbody> <tr> <td style="text-align: center;">XXXXXX</td> <td style="text-align: center;">XXXXXXXXXX</td> </tr> </tbody> </table>	LOOP TAGGING TABLE		LANE	TAG - NUMBER	XXXXXX	XXXXXXXXXX	<p>SG_VIDEO</p> <p style="text-align: center;"> Video Camera</p>		
LOOP TAGGING TABLE											
LANE	TAG - NUMBER										
XXXXXX	XXXXXXXXXX										

<p>SG_WP45</p>  <p>45° Class II Wood Pole with Down Guys & Anchor</p>	<p>SG_PICAB</p>  <p>TS2 Controller and Type P-1 Cabinet Min. 8 Phase on Type P-1 Foundation</p>		

<p><i>sht_num</i></p> <p>71 71</p>	<p><i>checkedby</i></p>	<p><i>signature</i></p>	<p><i>elect_sig_box</i></p>
<p><i>revisions</i></p> <pre> S00015 S00015 S00015 S00020 S00020 S00020 S00025 S00025 S00025 S00030 S00030 S00030 S00035 S00035 S00035 S00040 S00040 S00040 S00045 S00045 S00045 S00050 S00050 S00050 S00055 S00055 S00055 S00060 S00060 S00060 S00065 S00065 S00065 S00070 S00070 S00070 S00075 S00075 S00075 S00080 S00080 S00080 S00085 S00085 S00085 S00090 S00090 S00090 S00095 S00095 S00095 S00100 S00100 S00100 S00105 S00105 S00105 S00110 S00110 S00110 S00115 S00115 S00115 S00120 S00120 S00120 S00125 S00125 S00125 S00130 S00130 S00130 S00135 S00135 S00135 S00140 S00140 S00140 S00145 S00145 S00145 S00150 S00150 S00150 S00155 S00155 S00155 </pre>			