

CHAPTER 205

Temporary Erosion and Sediment Control

Design Memorandum	Revision Date	Sections Affected
15-06	Mar. 2015	205-3.02(03)
16-11	Mar. 2016	205-4.0
16-27	Jul. 2016	205-2.0, 205-3.0, 205-5.0, Fig. 205-1A

TABLE OF CONTENTS

TABLE OF CONTENTS.....	2
LIST OF FIGURES	3
CHAPTER 205	4
205-1.0 GENERAL INFORMATION.....	4
205-2.0 EROSION AND SEDIMENT CONTROL PLAN DEVELOPMENT [Added JUL. 2016]	5
205-2.01 Site Analysis [Rev. Jul. 2016]	5
205-2.02 Plan Requirements [Added Jul. 2016].....	6
205-2.03 Plan Information for Erosion and Sediment Control Measures [Added Jul. 2016] ...	8
205-3.0 TEMPORARY EROSION AND SEDIMENT CONTROL MEASURES [Rev. JUL. 2016]	8
205-3.01 Protection of Adjacent Areas [Rev. Jul. 2016].....	8
205-3.01(01) Silt Fence	8
205-3.01(02) Vegetative Filter Strip [Rev. Jul. 2016].....	9
205-3.01(03) Filter Berm	9
205-3.01(04) Sediment Trap [Rev. Jul. 2016].....	10
205-3.01(05) Sediment Basin [Rev. Jul. 2016].....	11
205-3.01(06) Temporary Stable Construction Entrance	12
205-3.02 Slope.....	13
205-3.02(01) Diversion Interceptor	13
205-3.02(02) Slope Drain	14
205-3.02(03) Temporary Seeding and Temporary Mulch [Rev. Mar. 2015]	14
205-3.02(04) Manufactured Surface Protection Products and Surface Roughening	14
205-3.03 Side Ditch	15
205-3.03(01) Check Dam.....	15
205-3.03(02) Modified Check Dam.....	15
205-3.04 Inlet Protection [Rev. Jul. 2016].....	16
205-3.05 Quantities [Added Jul. 2016].....	16
205-4.0 STORM WATER QUALITY MANAGER [Added MAR. 2016].....	16
205-5.0 REFERENCES [Rev. JUL 2016]	17
FIGURES	18

LIST OF FIGURES

<u>Figure</u>	<u>Title</u>
<u>205-1A</u>	<u>Erosion and Sediment Control Plan Technical Review Checklist</u> [Rev. Jul. 2016]
<u>205-3A</u>	<u>Slope Length for Silt Fence</u>
<u>205-3B</u>	<u>Silt Fence Application</u>
<u>205-3C</u>	<u>Minimum Filter Strip Application</u>
<u>205-3D</u>	<u>Vegetative Filter Strip Application</u>
<u>205-3E</u>	<u>Sediment Traps in V-Ditches</u>
<u>205-3F</u>	<u>Sediment Traps in Flat Bottom Ditches</u>
<u>205-3G</u>	<u>Flood Pool Length</u>
<u>205-3H</u>	<u>Sediment Basin Details</u>
<u>205-3I</u>	<u>Spacing for Diversion Type B</u>
<u>205-3J</u>	<u>Disturbed Side Ditch Treatment</u>
<u>205-3K</u>	<u>Undisturbed Side Ditch Treatment</u>

TEMPORARY EROSION AND SEDIMENT CONTROL

205-1.0 GENERAL INFORMATION

An erosion and sediment control plan, also known as a storm water management plan, should be developed where soil is disturbed, especially where sediment can enter a waterway or move off site. The erosion and sediment control plan should address erosion and sediment control during the entire construction process. Different measures will likely be used during different phases of construction. Allowance should be made for changes in the field to accommodate existing conditions or the use of different measures where they are more appropriate.

The goals of erosion control and sediment control are different. The purpose of placing erosion control measures is to prevent sediment from being mobilized on the project site. Sediment control measures are placed to recapture soil that has been mobilized and prevent it from leaving the construction site. Water flowing through a construction-disturbed area is to be filtered of sediment before it mixes with water which is not affected by construction operations. The guidelines presented in this chapter concentrate on temporary erosion and sediment control measures. The designer should coordinate with the Division of Environmental Services to determine the need for permanent erosion and sediment control measures.

INDOT *Standard Specifications* and *Standard Drawings* show existing temporary erosion and sediment control measures available to the designer. The erosion and sediment control measures described herein have been listed in groups according to their use. Some of the measures may be used in multiple applications. These guidelines will aid the designer in choosing the appropriate measures and frequency of their use. Erosion and sediment control measures should be designed at a minimum for a 2-yr 24-h rain event unless otherwise stated.

An erosion and sediment control plan known as a Storm Water Pollution Prevention Plan (SWPPP), is required to be submitted to the Indiana Department of Environment Management (IDEM) to comply with 327 IAC 15-5 (Rule 5). Rule 5 Notice of Intent (NOI) is a key component of the permitting process in order to maintain compliance with other water quality permits such as 404, 401, and DNR permits. See the INDOT *Waterway Permits Manual* at <http://www.state.in.us/indot/2522.htm> for additional permit information.

Formal submittal to comply with Rule 5 is required where 1 acre or more is disturbed. A copy of Rule 5 Notice NOI is available via the IDEM website, at <http://www.in.gov/idem/4914.htm> . It lists

items that should be submitted to IDEM with the erosion and sediment control plan. The designer should consider all items listed in Figure [205-1A](#) Erosion and Sediment Control Plan Technical Review Checklist. The erosion and sediment control plan should be prepared and submitted to IDEM. The NOI letter should be filed with IDEM. The submittals should be as follows

1. Plans developed for an INDOT project will be filed by the Environmental Services Division permit coordinator.
2. Plans developed for a local public agency project will be filed by the local agency or its representative to the Soil and Water Conservation District.
3. Plans developed by a contractor, i.e., design build or lump-sum erosion control, will be signed by the contractor first and then by the Environmental Services manager or representative. Plans are submitted to IDEM by the contractor.

205-2.0 EROSION AND SEDIMENT CONTROL PLAN DEVELOPMENT [ADDED JUL. 2016]

205-2.01 Site Analysis [Rev. Jul. 2016]

The erosion and sediment control plan should identify control measures that will be used to minimize erosion and off-site sedimentation. It serves as a blueprint for the location, installation, and maintenance of these measures.

In preparing the erosion and sediment control plan, the designer should start by observing local **and regional drainage areas**, geometric site constraints, and topography. The volume of water entering and leaving the construction site at various locations should be considered. Where reasonable, off-site waters should be isolated and allowed to pass through the project site. Sediments from on-site sources should be captured prior to leaving the site. The method of treatment depends upon the drainage area.

Providing a vegetated ground cover is most important in terms of preventing erosion. If the existing vegetation is to be disturbed, appropriate erosion and sediment control measures should be utilized. If utility features traverse the site, their relocation should be considered in designing these measures.

The following principles of erosion and sediment control should be utilized.

1. The physical characteristics of the site should be assessed, including topography and drainage, to determine how to best minimize erosion and sedimentation.

2. The erosion and sediment control plan should be designed to include measures that will keep sediment on the construction site as much as possible.
3. Where reasonable, a diversion interceptor or waterway should be used to divert or intercept off-site runoff. If the designer determines that the use of a diversion interceptor for off-site runoff is not practical, the designer should increase the size or quantity of proposed erosion and sediment control measures to satisfy the additional volume of water being treated from off-site runoff.
4. Measures to slow runoff and allow deposition of sediment should be designed using grading and sediment barriers to break up a long, steep slope.
5. A temporary seeding quantity in accordance with 205-3.02(03) should be provided for each area of disturbed soil.
6. Runoff velocity should be reduced by means of maintaining existing vegetative cover, preserving a natural buffer strip around the lower perimeter of the disturbed land, and installing perimeter controls such as silt fences, filter berms, and sediment basins or traps.
7. The contractor should be provided adequate working space to construct, repair, and maintain erosion control features.
8. A typical erosion control design is believed to comprise 1% of the estimated construction cost. The designer should use this threshold of 1% as a check in their design process. When the estimated erosion control cost does not reach the 1% threshold, the designer should review the plan and either make revisions or provide a design justification for not meeting this spending threshold which is intended to protect adjacent properties and Waters of the US.
9. No erosion and sediment control measures can be placed within a jurisdictional waterway or wetland unless permitted through the IDEM 401 and/or Corps of Engineers 404 permitting processes.

The construction clear-zone should be considered when selecting the appropriate erosion control measures. [Chapter 82](#) includes the information necessary to determine the construction clear-zone. For example, traversable check dams such as straw bales, fiber rolls, or fiber socks should be used instead of riprap check dams inside the construction clear-zone.

205-2.02 Plan Requirements [Added Jul. 2016]

The project plans should include Temporary Erosion and Sediment Control plan sheets to provide general information and to detail the specific erosion and sediment control measures to be utilized. Figure 205-1A provides a checklist of the items that are required to be shown on these plan sheets.

One of the important purposes of the Temporary Erosion and Sediment Control plan sheets is to provide an overall view of the drainage pattern in the areas both adjacent to and within the project site. The following checklist items are important to achieve this purpose:

1. Locations where off-site drainage will enter the project site. Where a defined channel is present, the drainage area and stream name, if available, should be labeled on the plan sheet. If no defined channel is present, the area draining towards the site should be delineated on the plan sheet and be labeled with the drainage area.
2. Locations of the specific points where storm water discharge will leave the site. The plans should identify each discharge location in terms of the type of conveyance (open channel, storm sewer, groundwater infiltration, etc.), the name and/or owner of the receiving facility and whether the discharge is into a municipal separate storm sewer system.
3. Any jurisdictional waterways and/or wetland areas identified in the project Waters Report should be labeled and delineated.
4. Soil information for the project site and the adjacent areas. Soil information for the adjacent areas should cover an appropriate distance around the project site and at a minimum should include all of the off-site drainage areas described in bullet point 1, above. This information should include a soils map taken from the NRCS National Cooperative Soil Survey. Each soil area on the map should be labeled with its code, and a table should be provided to relate each code with its corresponding soil classification.

A variety of resources are available to assist the designer in obtaining the data described above. Section 205-4.0 provides a list of these resources.

Erosion and sediment control measures should be designed in phases to correspond to the project construction phasing. As a general rule, a separate set of Erosion and Sediment Control plan sheets will be needed for each phase of the construction, depending on the overall complexity of the project. Temporary erosion and sediment control measures are typically constructed in conjunction with maintenance of traffic. Thus, phasing for temporary erosion and sediment control should correspond with the maintenance of traffic phasing.

205-2.03 Plan Information for Erosion and Sediment Control Measures [Added Jul. 2016]

In general, sufficient information can be provided for the measures in the erosion and sediment control plan by delineating the location of each measure on the plan sheet and providing a table of quantities. The location of each measure to be implemented should be represented on the plan sheet with an appropriate symbol.

The plan sheet should include a separate table of quantities for each category of measure (e.g. inlet protection or check dams), with a line in the table for each measure to be installed. The table should identify the location of each measure by line and station as well as whether it will be on the left or right side. The table should also include the quantity for each measure, based on the pay item units listed in the project specifications.

A few measures will require more detailed design information than can be shown in a table of quantities. Any additional information to be shown on the plan sheets for a specific type of measure is listed in Section 205-3.0.

To the extent possible, all of the erosion and sediment control measures listed in the project specifications should be delineated on the plan sheet. However, the locations of some categories of measure, such as temporary construction entrances, will be determined by the contractor during construction. Thus, it will not be necessary to show the locations of these measures on the plan sheets.

205-3.0 TEMPORARY EROSION AND SEDIMENT CONTROL MEASURES [REV. JUL. 2016]

205-3.01 Protection of Adjacent Areas [Rev. Jul. 2016]

Adjacent areas should be considered to be both off-site areas as well as within the right of way that are not proposed to be disturbed. The following measures are used to minimize sediment to areas adjacent to the disturbed areas. These measures include silt fence, vegetative filter strips, filter berms, sediment traps, and sediment basins.

205-3.01(01) Silt Fence

A silt fence captures sediment by pooling water to allow deposition, not by filtration. A silt fence requires a trench for proper installation and should not be used on a fill slope. Though the practice usually works best in conjunction with other erosion control measures, it can be effective where used alone under the proper field conditions. A silt fence should not be used to divert water. It should not be used across a stream, channel, or where concentrated flow is anticipated.

Use of a silt fence is limited to a disturbed drainage area of 0.25 ac/100 ft of fence. The use of silt fence is further restricted by the slope or grade, as indicated in Figures [205-3A](#) and [205-3B](#). The silt fence should be installed as level as possible while following the land contour. Ideally, silt fence should be installed at least 10 ft from the toe of slope to provide a broad, shallow sediment pool with increased storage capacity.

The length of a silt fence should be sufficient to encompass the boundaries of the toe of the slope with the ends of the fence terminated upslope. The silt fence should terminate at adjacent erosion control measures or at stabilized areas.

Where site conditions exceed the limits shown in Figure [205-3A](#), other appropriate erosion and sediment control measures should be implemented in conjunction with the silt fence. See the INDOT *Standard Drawings* series 205-TECP for details.

205-3.01(02) Vegetative Filter Strip [Rev. Jul. 2016]

A vegetative filter strip is an area where the ground cover is left undisturbed to filter runoff. Leaving existing grassy vegetation in place is the most effective method for erosion control. The designer should identify all potential areas for use of this control measure and evaluate each according to the minimum requirements shown in Figures [205-3C](#) and [205-3D](#).

A vegetative filter strip should be left between a sediment-producing site and a down slope site or watercourse. The effectiveness of a vegetative filter strip is dependent upon the slope of the undisturbed area. Where practical, the vegetative strip should be on the flatter area beyond the toe of slope. A site condition that does not allow for preserving a filter strip on the flatter ground, or existing vegetation that does not meet the minimum requirements shown in Figure [205-3C](#) should not preclude leaving as much vegetation on the slope as possible. In this situation, the vegetative filter strip should be used in conjunction with other measures such as silt fence, inlet protection, sediment trap, or sediment basin to increase effectiveness.

Typical applications for this sediment control measure include the area adjacent to the right-of-way limit, roadside ditch, relocated or existing waterway, or wetland. The vegetative filter strip may be considered for any undisturbed area within the construction limits. The locations which are not to be disturbed by the contractor should be **labeled and delineated** in the erosion and sediment control plan.

205-3.01(03) Filter Berm

A filter berm is a temporary barrier consisting of a compost, organic mulch, or No. 5 or 8 filter stone installed on the contour to intercept sheet flow and filter storm water runoff from a small, unvegetated drainage area. In an area prone to flooding, a riprap berm faced with filter stone should be used. Filter stone will be placed on the upslope side of the riprap berm, or the riprap should be wrapped in geotextile. The designer should show the berm ends turned upslope so that the ends of the berm terminate at higher elevations than the top of the berm at its lowest point. This will prevent water from flowing unfiltered around the berm.

The maximum drainage area for this measure is limited to 0.25 ac/100 ft of berm. A filter berm should not be placed on a slope steeper than 4:1. When placed at the toe of slope, the filter berm should be located 5 to 10 ft from the toe.

205-3.01(04) Sediment Trap [Rev. Jul. 2016]

A sediment trap is used to temporarily detain runoff and contain sediment in a drainage-flow area such as in a ditch line or swale. It is most often utilized as the last measure to filter water before it leaves the project site. Revetment riprap and No. 5 or 8 stone, along with geotextile, should be used in the construction of a sediment trap. The detained storage area should have a length-to-width ratio of 2:1 or greater. See the INDOT *Standard Drawings* series 205-TECD for details.

A sediment trap should be designed for a maximum drainage area of 5 acres. Where space is limited, the sediment trap should be designed considering the limited space rather than the drainage area. In this situation, other sediment control measures should be considered. To determine the volume of the trap, calculate the watershed acreage that is the tributary to the sediment trap. The trap should then be designed to store sediment for a minimum disturbed volume of 65 yd³/ac.

Figures [205-3E](#), [205-3F](#), and [205-3G](#) indicate the storage capacity and flood pool length for a sediment trap.

The sediment trap design depends on the following geometric characteristics of the proposed ditch:

1. ditch grade;
2. ditch shape, as flat bottom or V bottom; and
3. foreslope and backslope.

Figure [205-3G](#) indicates the minimum spacing for sediment traps, based on the flood pool length, so that the next measure cannot encroach into the pool of the previous one. The procedure used to determine spacing of multiple sediment traps is as follows.

1. Select the largest sediment trap, by spillway height, that can physically fit into the proposed ditch cross section.
2. Check the proposed ditch grade directly upstream of the approximate location of the sediment trap. The grade should be continuous.
3. Find the required minimum sediment-trap spacing from Figure [205-3G](#).

Each sediment trap shown on the Erosion and Sediment Control plan sheet should be labeled with the area in acres which drains to the trap, exclusive of the drainage areas at any upstream traps, as well as the total required storage volume within the trap.

205-3.01(05) Sediment Basin [Rev. Jul. 2016]

A sediment basin is a water-impoundment structure designed to hold the 10-yr 24-h rain event for the watershed passing through the site. The basin can be formed with an embankment or by means of excavation and is used to prevent offsite sedimentation by retaining sediment on the construction site. A sediment basin should be a primary consideration for a new-construction project where there is adequate right of way. It should be used within an interchange, rest area, weigh station, or replacement wetland. Where right of way is limited, the sediment basin should be designed considering available space rather than drainage area. In this situation, other control measures should be specified in conjunction with the sediment basin depending on site conditions.

The sediment basin will have a length-to-width ratio of 2:1 or greater. It must be shaped to fit the area in which it will be used. A sediment basin should be designed for a maximum drainage area of 30 acres. The basin should be designed to store a minimum water volume of 65 yd³/ac of watershed. If the watershed area is greater than 30 acres, additional measures should be considered. A berm should be placed around the pond that is at least 2 ft above the design elevation. An emergency spillway should be provided, typically as a weir, to drain excessive storm-event rainfall beyond the required design. The spillway crest should be set at least 1 ft higher than the design elevation. The spillway location will be determined based on the available right of way. However, the spillway should not be directly above the outlet pipe.

For guidance in the use of a wetlands replacement site as a sediment basin, contact the Office of Hydraulics. If the permanent control structure of the wetlands replacement site or detention

pond is a pipe, a temporary perforated riser with an anti-seep collar and anti-flotation block should be used to dewater the basin allowing for adequate residence time in the basin.

This sediment control measure should not be used where failure of the embankment can endanger life or property.

Because a sediment basin can potentially store a significant amount of water, a specific design will typically be required. The Erosion and Sediment Control plan sheets should provide specific design details for each basin, based on the design computations. In most circumstances, a separate plan sheet will be needed to show these details. The details shown on this plan sheet should include the following:

1. The design storm event.
2. The area, in acres, draining to the basin and the curve number used for runoff computations.
3. Construction details for any embankment that may be required.
4. The design storage elevation.
5. The required storage volume.
6. The crest elevation and width for the overflow spillway.
7. Details for the outlet pipe and riser.
8. Other details as appropriate.

See Figure [205-3H](#) for an example of the design details.

205-3.01(06) Temporary Stable Construction Entrance

A temporary stable construction entrance is a sediment control measure consisting of a stabilized aggregate pad over geotextile. A temporary construction entrance is used where construction traffic will be coming from a construction site to an adjoining public right of way, street, alley, sidewalk, or parking area minimizing the tracking of mud and sediment onto a public roadway. See the INDOT *Standard Drawings* E 205-TECP-01 for details. The designer should use the minimum values of 100 tons of No. 2 stone and 235 yd² of geotextile when estimating quantities. This should be sufficient to provide two stable construction entrances. The designer will

determine the need for additional construction entrance quantities based on the number of road and stream crossings within the project limits.

205-3.02 Slope

The following measures are used to temporarily control erosion on a slope. They include diversion interceptor and slope drain, vegetative strip in a cut or fill section, temporary seeding and temporary mulch, erosion control blanket, and surface roughening.

205-3.02(01) Diversion Interceptor

1. Type A, Embankment Diversion. An embankment diversion is a storm water control measure consisting of a temporary ridge, excavated channel, or combination thereof constructed across a slope to collect storm water runoff and divert it to a treatment device with a stable outlet. An embankment diversion should have the capacity to accommodate a maximum drainage area of 3 acres. The side slopes should be 2:1 or flatter with a top ridge or bottom channel width of 2 ft allowing for 6 in. of freeboard.
2. Type B, Water Bar or Transverse Diversion. This consists of a series of small ridges, or ridges and channels, used to intercept and divert storm water runoff from a long narrow corridor such as a haul road. Diverted storm water should be discharged into a treatment device with a stable outlet. The length of a water bar should not exceed 100 ft. Its grade should not exceed 2% towards the outlet. Ridge height should be a minimum of 9 in. from the down slope ground level to the top of settled ridge. Water-bar spacing shall be as shown in Figure [205-3 I](#), Spacing for Diversion Type B.
3. Type C, Perimeter Diversion. This is used to collect offsite runoff before it enters the project site. A maximum drainage area of 5 acres is allowed before additional considerations are required by the designer. A perimeter diversion consists of a stable channel and supporting ridge constructed across a slope to collect storm water runoff and divert it to a stable outlet. Side slopes should be 2:1 or flatter with a minimum ridge top or channel bottom width of 2 ft, allowing 6 in. of freeboard and stabilized with vegetation unless a ditch grade of 6% or steeper warrants the use of riprap with geotextile. The runoff diverted away from the project site will be exempt from using a sediment treatment measure. However, a stable outlet may be needed in order to release water onto stable terrain. Perimeter diversion measures remain in place for the duration of construction.

See the INDOT *Standard Drawing* E 205-TECS-01 and E 205-TECS-04 for details.

205-3.02(02) Slope Drain

A slope drain is a pipe drain used in conjunction with a diversion interceptor to convey runoff down a slope without causing erosion. A diversion interceptor with a slope drain should be specified at the top of a fill or cut slope to divert runoff from the top of the embankment and control where the runoff is discharged. Where the cut or fill height exceeds 10 ft, a slope drain should be used. The INDOT *Standard Drawings* E 205-TECS-02 & E 205-TECS-03 specifies the pipe diameter and its drainage area. This information should be used in determining the spacing of slope drains.

The contractor should be permitted to use a temporary pipe slope drain or an open slope drain. The slope drain should be lengthened as the embankment is extended upward. A slope drain should not be outlet directly into a stream due to the possible conveyance of sediment from the top of the embankment. Instead, it should be outlet onto a riprap splash pad and into another sediment control measure.

205-3.02(03) Temporary Seeding and Temporary Mulch [Rev. Mar. 2015]

Temporary seeding and mulch are used to reduce erosion and sedimentation damage by means of stabilizing a disturbed area where additional work is not scheduled for at least 7 calendar days. Temporary seeding reduces problems associated with mud or dust from bare soil surfaces during construction. It also reduces sediment runoff downstream by providing temporary stabilization. Mulch protects the soil from the impact of wind and water, prevents the soil from crusting, conserves moisture, and promotes seed germination and growth.

The pay quantity for temporary seeding and temporary mulch should be determined in accordance with Section 17-6.0 Temporary Seeding and Temporary Mulch.

205-3.02(04) Manufactured Surface Protection Products and Surface Roughening

If manufactured surface protection products or erosion control blankets are required as a permanent measure, and the special provisions require their early installation, such measures may be used as a temporary erosion control measure. Although surface roughening is required by the INDOT *Standard Specifications* for construction of erosion control methods, the designer need not consider surface roughening as part of the temporary erosion and sediment control plan.

205-3.03 Side Ditch

The measures used to control sediment in a side ditch include check dam, sediment trap, and grass or riprap-lined channel. Figure [205-3J](#) shows the measures to be used with a disturbed ditch. Figure [205-3K](#) shows the measures to be used with an undisturbed ditch.

205-3.03(01) Check Dam

A check dam is used to reduce erosion and control sediment in a drainage channel by slowing the velocity of the flow. A check dam is used in a channel that is degrading but where permanent stabilization measures are impractical due to their short period of usefulness. It is also used in eroding channels where construction delays or weather conditions prevent timely installation of erosion-resistant linings. A check dam should not be used in jurisdictional waters.

A check dam is an appropriate erosion control measure for a drainage area of 2 acres or less. For a drainage area of more than 2 acres, other erosion and sediment control measures will be needed. A revetment-riprap check dam should be specified for use if it will be outside the construction clear-zone. A traversable check dam should be specified only if it will be inside the construction clear-zone, or for site specific needs. See the INDOT *Standard Drawing E 205-TECD-01* for details. In any case, the check dam should be wide enough to traverse the ditch section so as to force water to flow over the check dam instead of around the ends.

The cross section for a revetment-riprap check dam is shown in the INDOT *Standard Drawings*. The check dams should be spaced such that the top of the downstream check dam is at the same elevation as the toe of the adjacent upstream check dam. For a traversable check dam, the spacing should be calculated, although it is not necessary to show the spacing on the plans.

205-3.03(02) Modified Check Dam

A modified check dam is used as an erosion and sediment control measure to filter runoff water at critical points along the ditch line. It includes an additional layer of filter stone as shown in the INDOT *Standard Drawing E 205-TECD-01*. At a minimum, the locations within the project limits that require a modified check dam are as follows:

1. on the flatter of the 2 slopes at a grade break of 1% or more in a ditch line;
2. at a pipe inlet or stream crossing where right-of-way limitations prohibit the placement of a sediment trap or sediment basin as described in sections [3.01\(04\)](#) and [3.01\(05\)](#);
3. the final check dam location prior to placement of a sediment trap or basin; or

4. at the final check dam location prior to water entering a permanent vegetated ditch.

Unless otherwise specified, one fourth of the check dams, evenly distributed, shall be modified check dams. If the geotechnical report indicates erosive soils, modified check dams shall be used throughout the project limits. However, this measure is not to be used where the contractor will have difficulty accessing the dam for maintenance.

205-3.04 Inlet Protection [Rev. Jul. 2016]

Prevention of sedimentation of a stream includes protection of storm water inlets. Inlet protection is used to keep sediment from entering an inlet, allowing for full operation of the storm-drain system during the construction period. Inlet protection is needed for any inlet where the project plans will create disturbed area within the inlet catchment area. In order to adequately protect an inlet, it may be necessary to combine inlet protection with other erosion and sediment prevention measures. Inlet protection should also be provided for an inlet in a paved area where there is a potential for sediment to wash onto the road from surrounding areas or be tracked by construction equipment.

The contractor has the option of using sandbag, or basket-insert inlet protection for a curb or deck inlet. A maximum drainage area of 1 acre applies to the sandbag method. A maximum drainage area of 0.25 acre applies to the bag-insert method. If the drainage area is greater than 1 acre per inlet, additional measures should be used in conjunction with the inlet-specific protection measures described here.

See the INDOT *Standard Drawings* series 205-TECI for details.

205-3.05 Quantities [Added Jul. 2016]

Most contracts will include two pay items Storm Water Quality Management Budget and Storm Water Quality Control Plan (SWQCP). Pay quantities Storm Water Quality Management Budget and Storm Water Quality Control Plan (SWQCP) should be determined in accordance with Section 17-6.0.

205-4.0 STORM WATER QUALITY MANGER [ADDED MAR. 2016]

The designer must identify a Storm Water Quality Manger (SWQM) as Level 1 or Level 2 for each contract. A contractor's Level 1 SWQM must have completed the Department's Construction Storm Water Training course and hold a current training verification document for that course. A Level 2 SWQM must meet the Level 1 requirements and hold a current certification as a Certified Erosion

Sediment and Storm Water Inspector (CESSWI), or a CESSWI In-Training, or a Certified Inspector of Sediment and Erosion Control (CISEC), or a CISEC In-Training, or a Certified Professional in Erosion and Sediment Control (CPESC), or a CPESC In-Training, or an approved equivalent.

An initial SWQM level recommendation will be provided by the Environmental Services Division (ESD) as an item in the project commitments. Guidelines for recommending a SWQM Level 2 are not definitive but may include unfavorable soils, very tight right of way, nearby sensitive resources, or major environmental impacts. It is ultimately the designer's responsibility to coordinate with the ESD and the Area Engineer and to indicate the appropriate SWQM level for each project.

205-5.0 REFERENCES [REV. JUL 2016]

The designer should be familiar with the following references that pertain to erosion and sediment control design.

1. *Indiana Administrative Code*, Indiana General Assembly-Indiana Register, 327 IAC 15-5. Available at <http://www.in.gov/legislative/ic/code/title8/ar23/ch6.html>
2. *Federal Register*, Final Rule. 40CFR Chapter 1 Part 9, 122, 123, 124.
3. *Indiana Storm Water Quality Manual*. Available at <http://www.in.gov/idem/4899.htm>, Chapter 7.
4. *Web Soil Survey*. USDA, Natural Resources Conservation Service . Available at <http://websoilsurvey.sc.egov.usda.gov/App/HomePage.htm>, USDA, Natural Resources Conservation Service.
5. *Streamstats*. Available at <http://water.usgs.gov/osw/streamstats/indiana.html>, United States Geological Survey
6. *Precipitation Frequency Data Server*. Available at http://hdsc.nws.noaa.gov/hdsc/pfds/pfds_map_cont.html?bkmrk=in, NOAA, National Weather Service

EROSION AND SEDIMENT CONTROL PLAN TECHNICAL REVIEW CHECKLIST

The following is a check list of items that are required to be addressed on all Erosion and Sediment Control plans. *(The plans must include appropriate legends, scales, and north arrow.)*

PROJECT INFORMATION

- | Yes | No | | |
|--------------------------|--------------------------|----|--|
| <input type="checkbox"/> | <input type="checkbox"/> | 1A | Project location map (Show project in relation to other areas of the county.) |
| <input type="checkbox"/> | <input type="checkbox"/> | 1B | Narrative describing the nature and purpose of the project |
| <input type="checkbox"/> | <input type="checkbox"/> | 1C | Location of planned and/or existing roads, utilities ¹ , structures, highways, etc. |
| <input type="checkbox"/> | <input type="checkbox"/> | 1D | Building locations ² |
| <input type="checkbox"/> | <input type="checkbox"/> | 1E | Land use of adjacent areas <i>(Show the entire upstream watershed and adjacent areas within 500ft of the property lines.)</i> ³ |

TOPOGRAPHIC, DRAINAGE, AND GENERAL SITE FEATURES

- | Yes | No | | |
|--------------------------|--------------------------|----|---|
| <input type="checkbox"/> | <input type="checkbox"/> | 2A | Existing vegetation <i>(Identify and delineate.)</i> |
| <input type="checkbox"/> | <input type="checkbox"/> | 2B | Location/name of all wetlands, lakes, and water courses on and adjacent to site |
| <input type="checkbox"/> | <input type="checkbox"/> | 2C | 100-year floodplains, floodway fringes, and floodways <i>(not applicable if none.)</i> ⁴ |
| <input type="checkbox"/> | <input type="checkbox"/> | 2D | Soils information <i>(If hydric soils are present, it is the responsibility of the owner to investigate the existence of wetlands and obtain appropriate permits.)</i> ⁵ |
| <input type="checkbox"/> | <input type="checkbox"/> | 2E | Existing/planned contours ⁶ at intervals appropriate to indicate drainage patterns |
| <input type="checkbox"/> | <input type="checkbox"/> | 2F | Locations where off-site drainage will enter the site, along with the drainage area at each location and drainage area delineations as required. ⁷ |
| <input type="checkbox"/> | <input type="checkbox"/> | 2G | Locations of specific points where stormwater discharge will leave the site |
| <input type="checkbox"/> | <input type="checkbox"/> | 2H | Identify all receiving waters <i>(If discharge is to a separate municipal storm sewer, identify the name of the municipal operator and the ultimate receiving water.)</i> |
| <input type="checkbox"/> | <input type="checkbox"/> | 2I | Potential areas where storm water may enter groundwater <i>(note if none.)</i> |

¹ Use best available information.

² Within project area.

³ Attach the appropriate United States Geological Survey topographic map.

⁴ This item is satisfied by showing the 100-year flood elevation on the plans.

⁵ No formal submittal from the designer is necessary for this item.

⁶ Profiles or contours where available.

⁷ Where a defined channel is present, the drainage area and stream name should be labeled. Drainage area delineation is required only where no channel is present.

2J Location of storm water system (*Include culverts, storm sewers, channels, and swales.*)

LAND-DISTURBING ACTIVITIES

Yes No
 3A Location and approximate dimensions of all disturbed areas [*i.e., construction limits*] (*Areas where vegetation cover will be preserved should clearly be designated.*)
 3B Soil stockpiles and borrow areas⁸ (*Show location or note if none.*)

EROSION AND SEDIMENT CONTROL MEASURES

Yes No
 4A Sequence of each measure to be implemented⁸ (*Relative to earth-disturbing activities.*)
 4B Monitoring and maintenance guidelines for each measure⁹
 4C Perimeter sediment control measures (*Location, construction detail, dimensions, specifications.*)
 4D Temporary seeding (*Specifications including seed mix, fertilizer, lime, and mulch rates.*)⁹
 4E Temporary erosion and sediment control measures (*Location, construction detail, dimensions, specifications.*)
 4F Permanent erosion and sediment control measures (*Location, construction detail, dimensions, specifications.*)
 4G Storm drain inlet protection (*Location, construction detail, dimensions, specifications.*)
 4H Storm drain outlet protection (*Location, construction detail, dimensions, specifications.*)
 4I Stable construction entrance (*Location, construction detail, dimensions, specifications.*)⁷
 4J Permanent seeding (*Specifications including seed mix, fertilizer, lime, and mulch rates.*)⁸

⁸ To be submitted by the contractor following contract award.

⁹ This item addressed in Indiana Department of Transportation *Standard Specifications*.

Slope, $a:1$ (Grade, %)*	Maximum Slope Length, B^{**}
Flatter than 50:1 (< 2%)	100 ft
$50:1 \leq \text{Slope} < 20:1$ ($2\% \leq \text{Grade} < 5\%$)	80 ft
$20:1 \leq \text{Slope} < 10:1$ ($5\% \leq \text{Grade} < 10\%$)	50 ft
$10:1 \leq \text{Slope} < 5:1$ ($10\% \leq \text{Grade} < 20\%$)	30 ft
5:1 or Steeper ($\geq 20\%$)	20 ft

* *Steepest portion of the slope.*

** *The length of the slope above the fence that will be contributing runoff. This is not to be interpreted as a spacing distance between multiple rows of fence down a slope. Multiple or terraced rows of silt fence are not an approved application of this sediment-control measure.*

Figure 205-3B should be used with this figure.

SLOPE LENGTH FOR SILT FENCE

Figure 205-3A

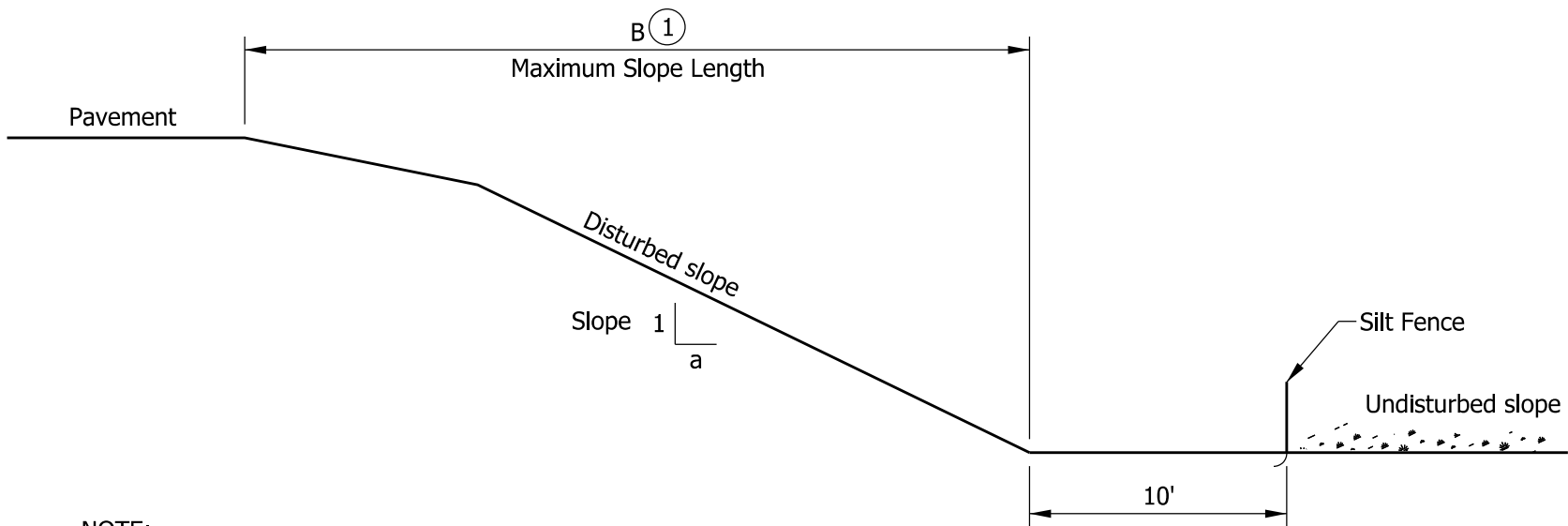

NOTE:

① See Figure 205-3C for B.

SILT FENCE APPLICATION

Figure 205-3B

Slope, $a:1$ (Grade, %) *	Minimum Recommended Filter Width, B	Maximum Slope Length, C **
Flatter than 20:1 (< 5%)	20 ft	$80 \text{ ft} \leq C < 100 \text{ ft}$
$20:1 \leq \text{Slope} < 10:1$ ($5\% \leq \text{Grade} < 10\%$)	40 ft	$50 \text{ ft} \leq C < 80 \text{ ft}$
$10:1 \leq \text{Slope} < 5:1$ ($10\% \leq \text{Grade} < 20\%$)	60 ft	$30 \text{ ft} \leq C < 50 \text{ ft}$
5:1 or Steeper ($\geq 20\%$)	80 ft	$20 \text{ ft} \leq C < 30 \text{ ft}$

* *Steepest portion of the slope*

** *Length of the slope above the filter strip that will contribute runoff.*

Note: Figure 205-3D should be used with this figure.

MINIMUM FILTER-STRIP APPLICATION

Figure 205-3C

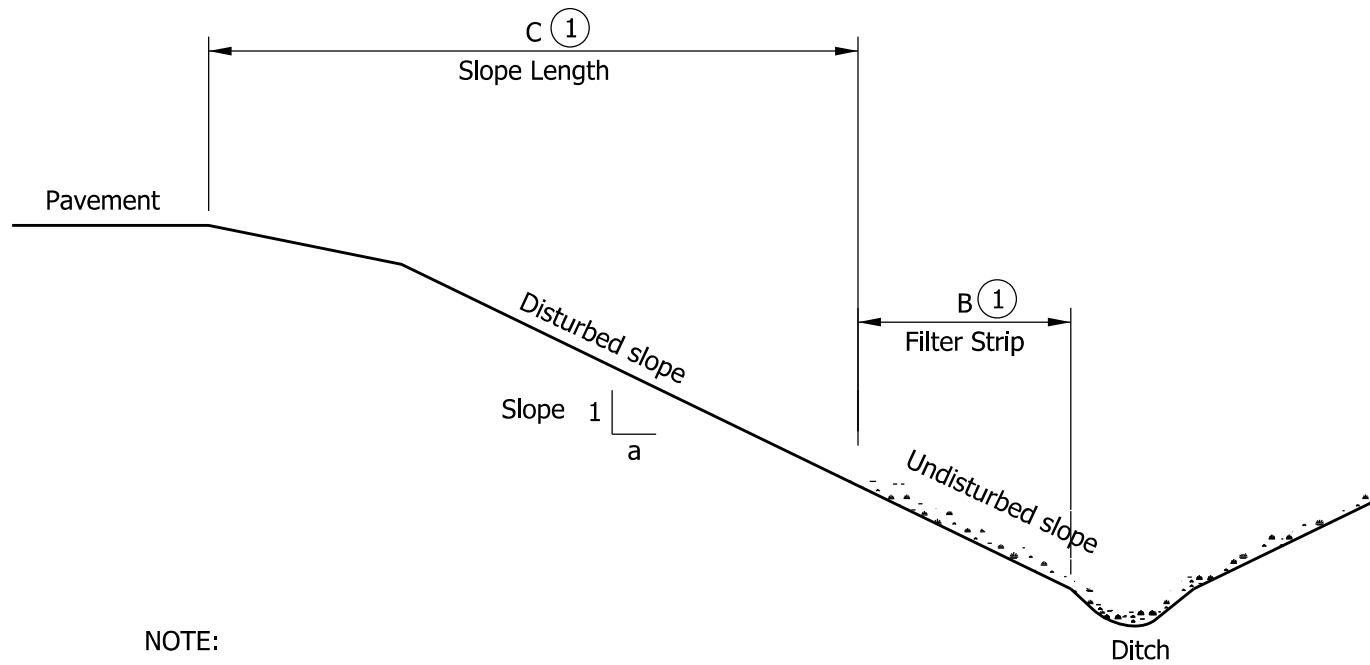

NOTE:

(1) See Figure 205-3C for B and C.

VEGETATIVE FILTER STRIP APPLICATION

Figure 205-3D

Spillway Height (ft)	STORAGE CAPACITY, ft ³ / SPACING, ft														
	2:1 Foreslope, 2:1 Backslope Ditch Grade, up to:					3:1 Foreslope, 2:1 Backslope Ditch Grade, up to:					3:1 Foreslope, 3:1 Backslope Ditch Grade, up to:				
	2%	3%	4%	5%	6%	2%	3%	4%	5%	6%	2%	3%	4%	5%	6%
2.0	$\frac{388}{67}$ *	$\frac{247}{43}$ *	$\frac{177}{33}$ *	$\frac{141}{27}$ *	$\frac{141}{20}$ *	$\frac{460}{83}$ *	$\frac{317}{53}$ *	$\frac{247}{40}$ *	$\frac{176}{33}$ *	$\frac{177}{27}$ *	$\frac{565}{100}$	$\frac{388}{67}$	$\frac{283}{50}$	$\frac{212}{40}$	$\frac{177}{33}$
2.5	$\frac{741}{127}$	$\frac{494}{87}$	$\frac{388}{63}$	$\frac{282}{50}$	$\frac{247}{43}$	$\frac{918}{160}$	$\frac{636}{107}$	$\frac{459}{80}$	$\frac{388}{63}$	$\frac{317}{53}$	$\frac{1130}{193}$	$\frac{742}{127}$	$\frac{565}{97}$	$\frac{459}{77}$	$\frac{388}{63}$
3.0	$\frac{1271}{220}$	$\frac{847}{147}$	$\frac{635}{110}$	$\frac{529}{90}$	$\frac{423}{73}$	$\frac{1624}{277}$	$\frac{1059}{183}$	$\frac{812}{137}$	$\frac{636}{110}$	$\frac{529}{93}$	$\frac{1942}{333}$	$\frac{1271}{220}$	$\frac{953}{167}$	$\frac{777}{133}$	$\frac{636}{110}$

* This spacing is for information only. Use the minimum spacing from Figure 205-3G instead.

SEDIMENT TRAP IN V-DITCH

Figure 205-3E

Spillway Height (ft)	STORAGE CAPACITY, ft ³ / SPACING, ft														
	3:1 Foreslope, 3:1 Backslope Ditch Grade, up to:					4:1 Foreslope, 3:1 Backslope Ditch Grade, up to:					4:1 Foreslope, 4:1 Backslope Ditch Grade, up to:				
	2%	3%	4%	5%	6%	2%	3%	4%	5%	6%	2%	3%	4%	5%	6%
2.00	$\frac{565}{77}$ *	$\frac{565}{77}$ *	$\frac{423}{57}$	$\frac{353}{47}$	$\frac{283}{37}$	$\frac{953}{130}$	$\frac{635}{87}$	$\frac{460}{63}$	$\frac{388}{53}$	$\frac{317}{43}$	$\frac{1059}{147}$	$\frac{706}{97}$	$\frac{530}{73}$	$\frac{424}{60}$	$\frac{353}{47}$
2.50	$\frac{1553}{217}$	$\frac{1060}{143}$	$\frac{777}{110}$	$\frac{636}{87}$	$\frac{530}{73}$	$\frac{1766}{247}$	$\frac{1165}{193}$	$\frac{883}{123}$	$\frac{706}{100}$	$\frac{600}{83}$	$\frac{1942}{280}$	$\frac{1306}{187}$	$\frac{953}{140}$	$\frac{777}{113}$	$\frac{636}{93}$
3.00	$\frac{2578}{367}$	$\frac{1730}{243}$	$\frac{1271}{183}$	$\frac{1024}{147}$	$\frac{848}{123}$	$\frac{2896}{420}$	$\frac{1942}{280}$	$\frac{1448}{210}$	$\frac{1165}{167}$	$\frac{953}{140}$	$\frac{3213}{477}$	$\frac{2154}{317}$	$\frac{1624}{237}$	$\frac{1271}{190}$	$\frac{1059}{160}$

Note: The values are calculated for a 3-ft width flat-bottom ditch. They are also suitable for use for a 4-ft width ditch, due to the proximity of the values.

SEDIMENT TRAP IN FLAT-BOTTOM DITCH

Figure 205-3F

Spillway Height, ft	Ditch Grade, up to:				
	2%	3%	4%	5%	6%
2.0	100	70.0	50.0	40.0	35.0
2.5	125	84.0	65.0	50.0	40.0
3.0	150	100	75.0	60.0	50.0
3.5	175	117	90.0	70.0	60.0

FLOOD-POOL LENGTH (ft)

Figure 205-3G

NOTES:

- ① When basin design is cut into the site's contours to meet capacity, the designer should include a stable surface for water to flow into the basin to prevent the slope from eroding. The design should include a riprap pad twice the channel width to slow and disperse water into the basin.
- ② Riprap channel shall extend 20' beyond the overflow toe at the dike and be discharged into a stable vegetated channel.
3. Basin shape varies and must have min. length-to-width ratio of 2:1.

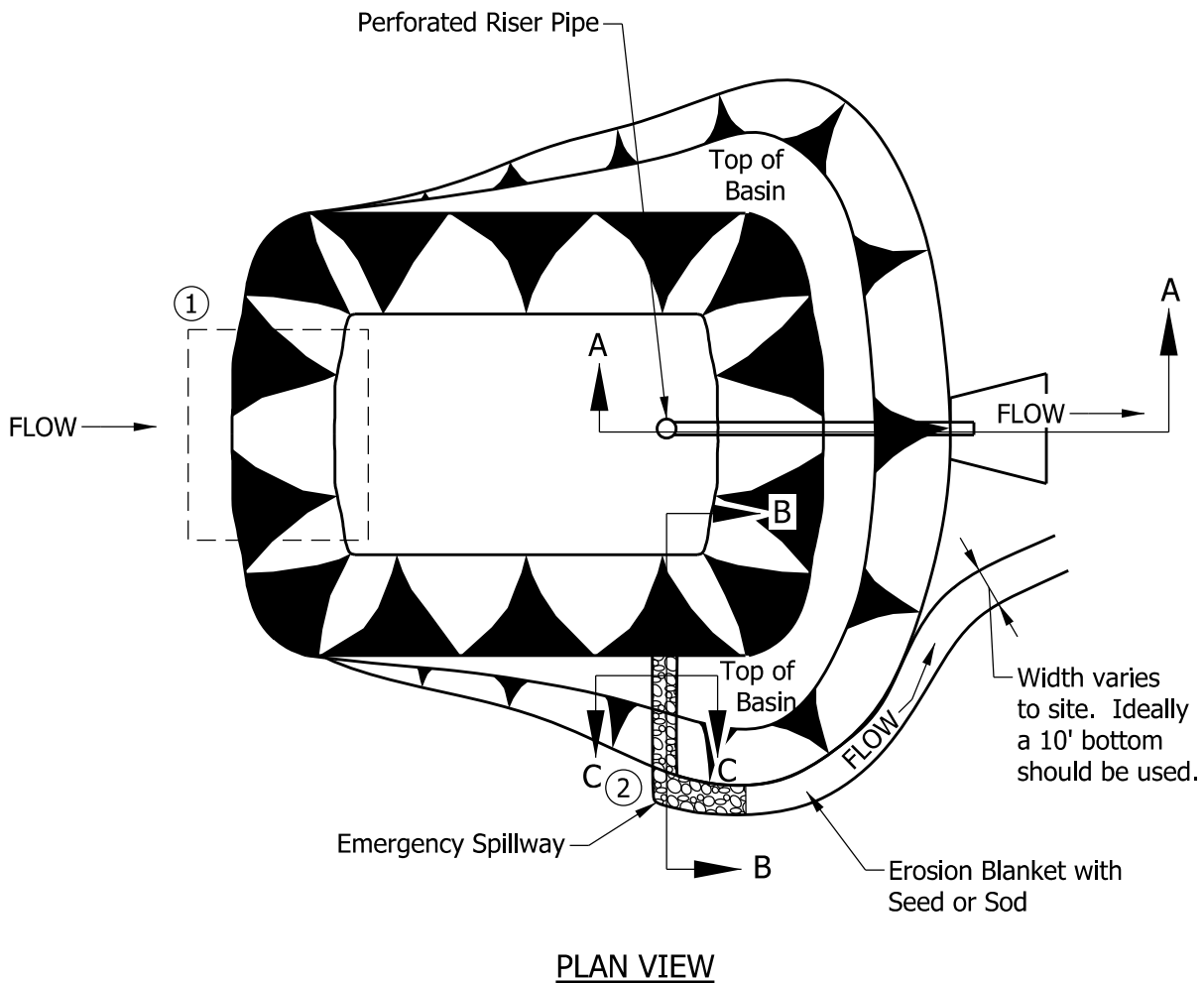

SEDIMENT BASIN

Figure 205-3H
(Page 1 of 3)

NOTES:

- ① Earth dam paid in accordance with 203. Soil for use in embankment will be as recommended by the geotechnical report.
- ② Keyway trench runs the length of the embankment if necessary for stability. See the geotechnical report for further guidance.

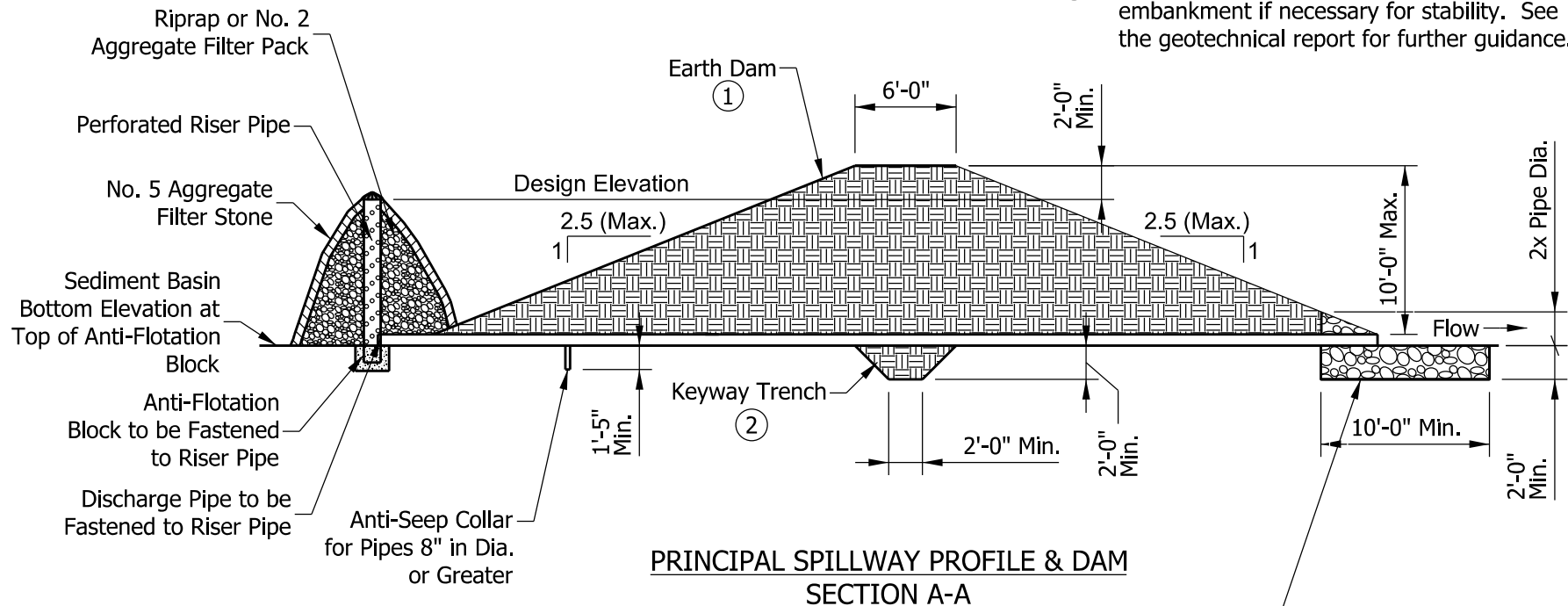

**PRINCIPAL SPILLWAY PROFILE & DAM
SECTION A-A**

SEDIMENT BASIN

**Figure 205-3H
(Page 2 of 3)**

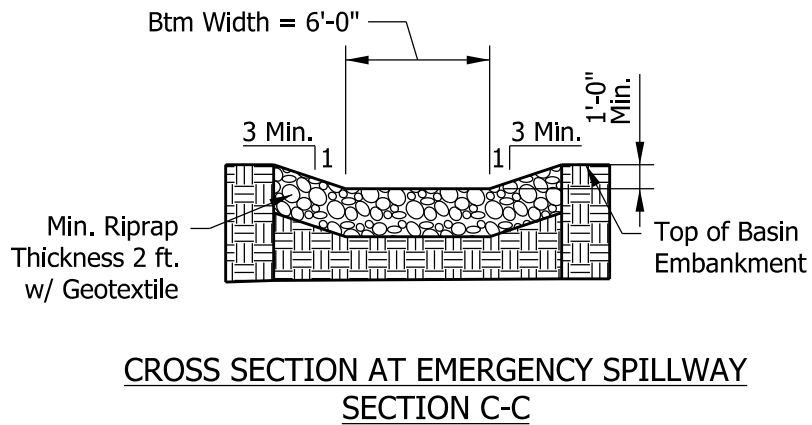
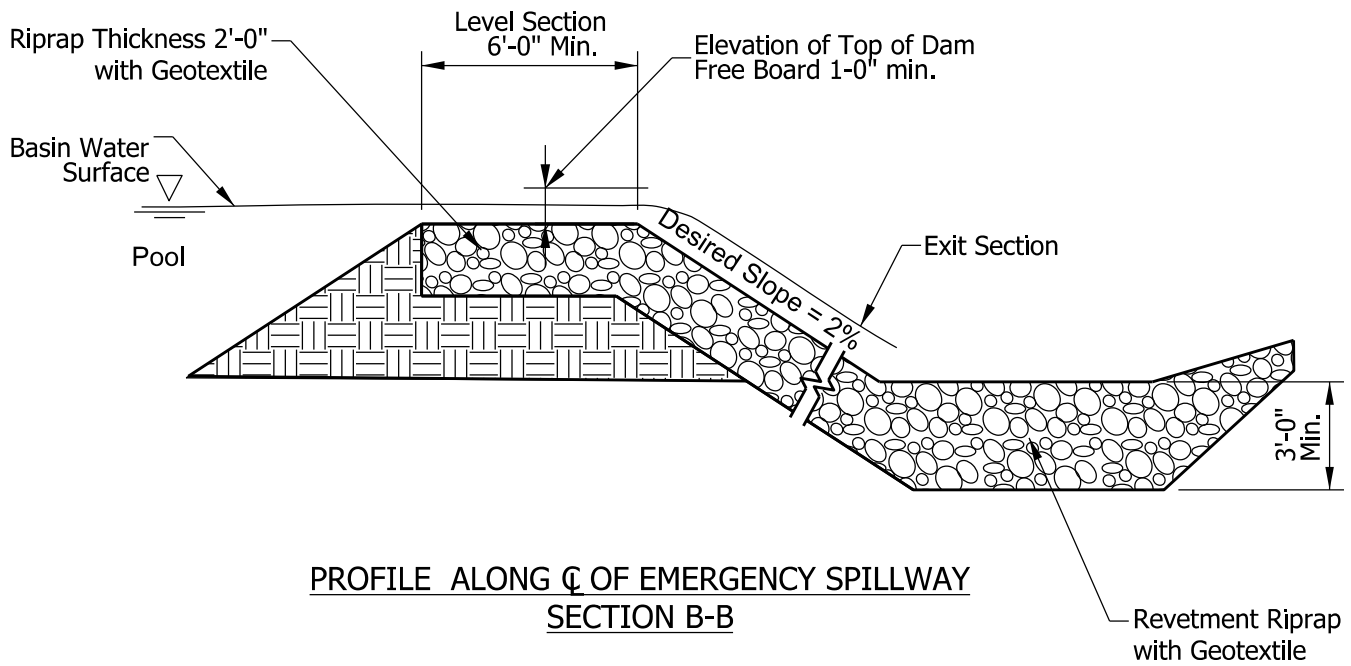

SEDIMENT BASIN

Figure 205-3H
(Page 3 of 3)

Slope, S	Grade, G	Spacing
$< 5\%$	$< 20:1$	125 ft
$5\% \leq S < 10\%$	$20:1 \leq G < 10:1$	100 ft
$10\% \leq S < 20\%$	$10:1 \leq G < 5:1$	75 ft
$20\% \leq S < 33\%$	$5:1 \leq G < 3:1$	50 ft
$\geq 33\%$	$> 3:1$	25 ft

SPACING FOR DIVERSION TYPE B

Figure 205-3 I

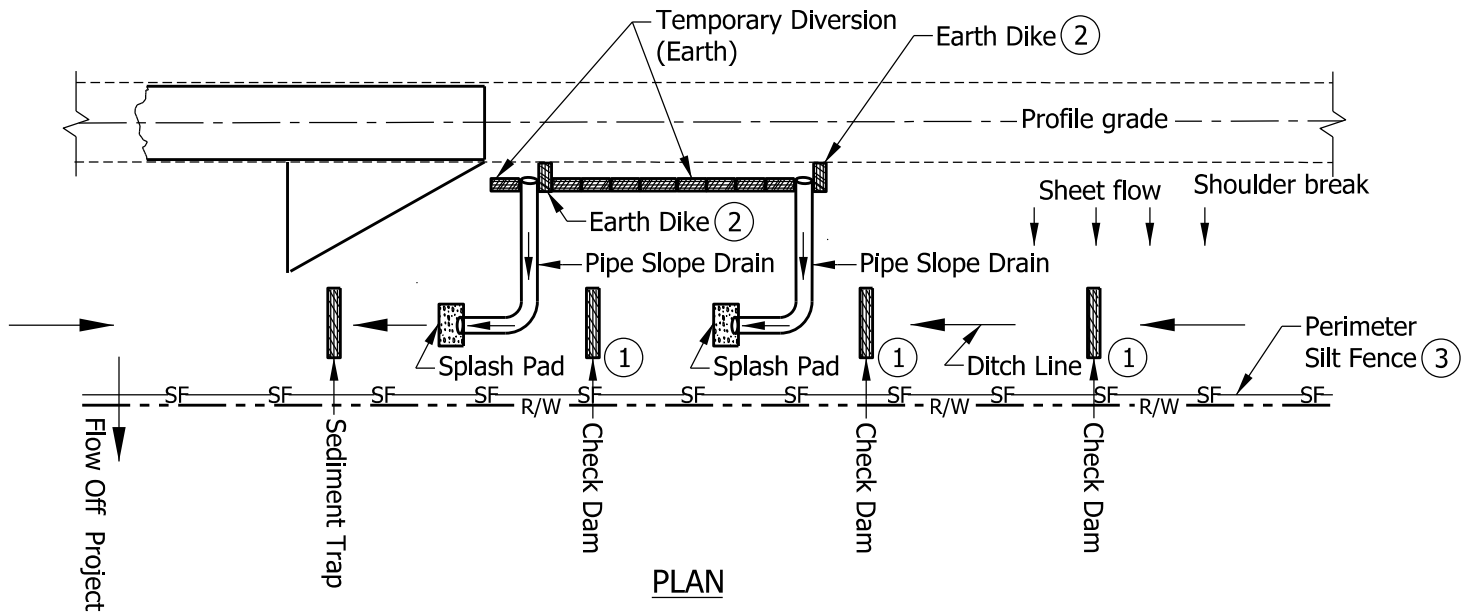

PLAN

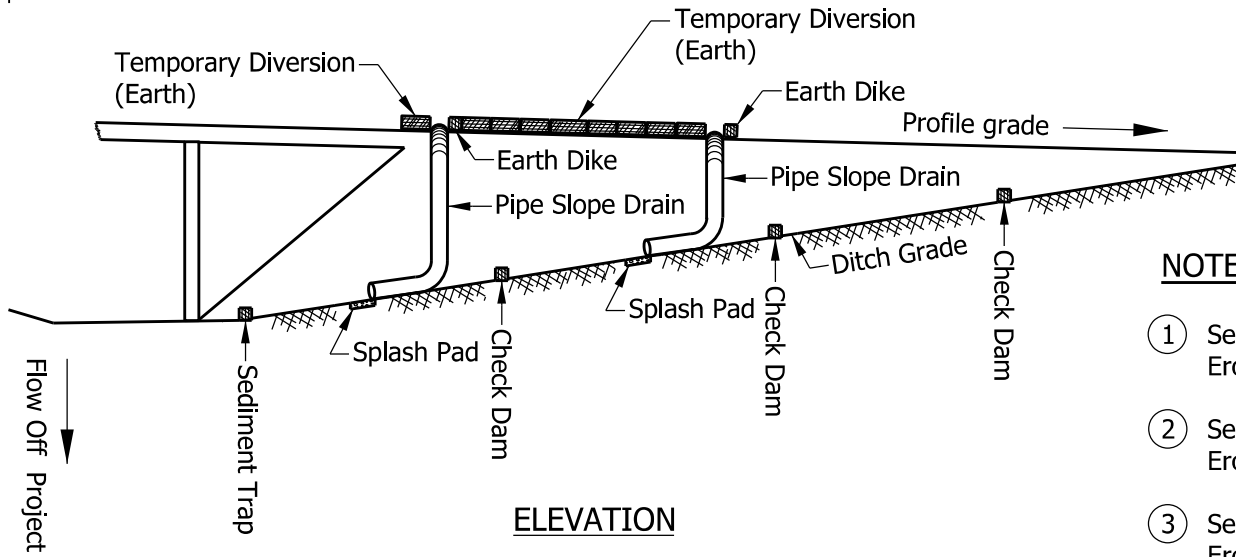

ELEVATION

NOTES:

- ① See INDOT Standard Drawings Temporary Erosion Control Ditch series.
- ② See INDOT Standard Drawings Temporary Erosion Control Slope series.
- ③ See INDOT Standard Drawings Temporary Erosion Control Perimeter series.

DISTURBED SIDE DITCH TREATMENT

Figure 205-3J

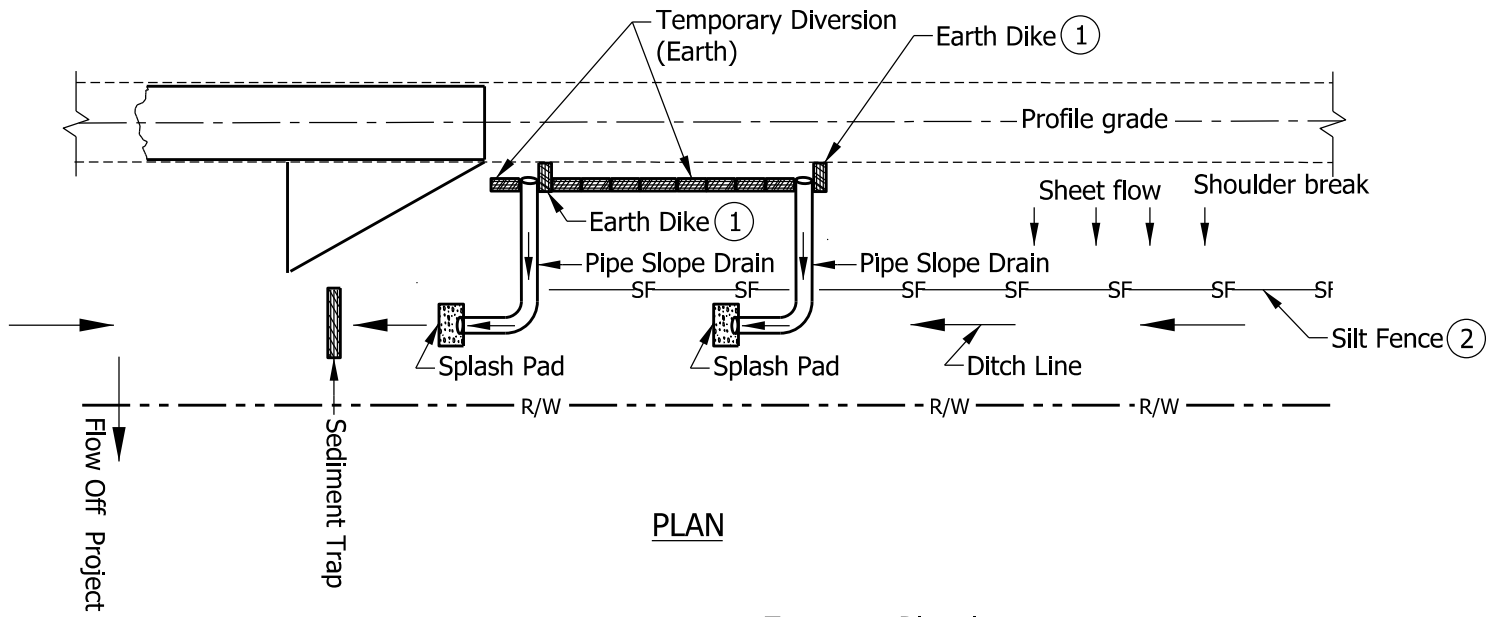

PLAN

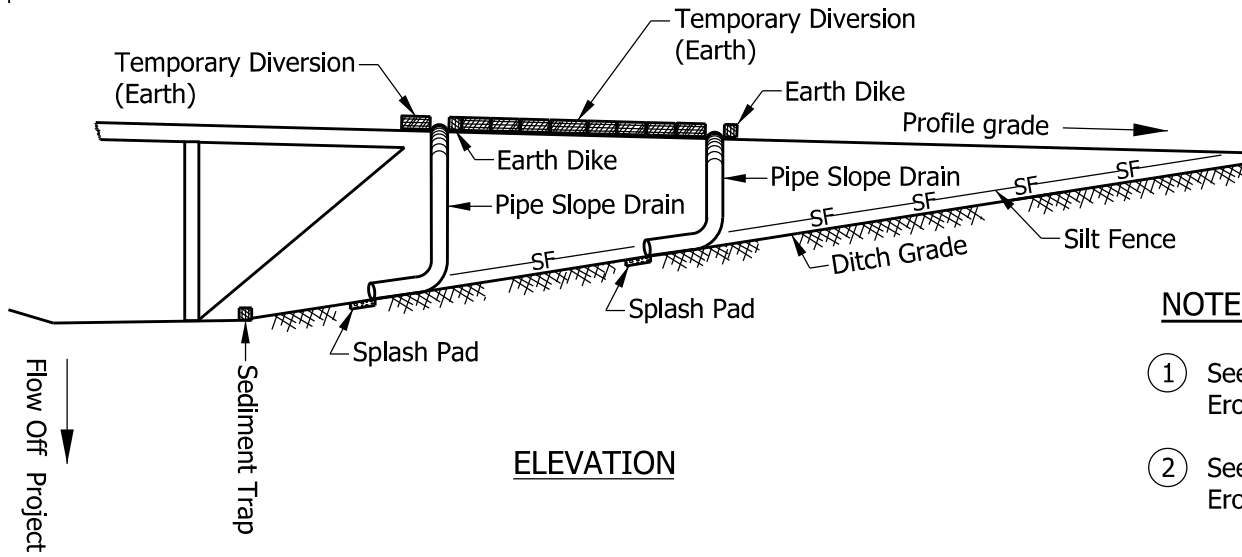

ELEVATION

NOTES:

- ① See INDOT Standard Drawings Temporary Erosion Control Slope series.
- ② See INDOT Standard Drawings Temporary Erosion Control Perimeter series.

UNDISTURBED SIDE DITCH TREATMENT

Figure 205-3K