

TABLE OF CONTENTS

TABLE OF CONTENTS..... 1

LIST OF FIGURES 4

48-2A Freeway Interchanges (Based on Functional Classification of Intersecting Facility)
4

48-2B Diamond Interchange..... 4

48-2C Single Point Urban Interchange 4

48-2D Three-Level Diamond Interchange..... 4

48-2E Full Cloverleafs..... 4

48-2F Partial Cloverleaf Arrangements..... 4

48-2G Three-Leg Interchanges 4

48-2H Fully Directional Interchange 4

48-2 I Semi-Directional Interchanges..... 4

48-3A Typical Examples of Lane Balance 4

48-3B Recommended Minimum Ramp Terminal Spacing 4

48-3D Alternate Methods of Dropping Additional Lanes 4

48-4A Typical Exit Ramp Types (Single Lane) 4

48-4B Typical Gore Area Characteristics..... 4

48-4C Typical Entrance Ramp Types (Single Lane)..... 4

48-4D Minimum Acceleration Lengths for Entrance Terminals With Flat Grades of 2 % or
Less 4

48-4E Grade Adjustments for Acceleration (Passenger Cars) 4

48-4F Lengths for Acceleration (200 lb/hp Truck) 4

48-4G Multi-Lane Entrance Ramp (Service Interchanges) 4

48-4H Multi-Lane Exit Ramp (Service Interchanges)..... 4

48-4 I Major Forks for System Interchanges (Typical Schematics)..... 4

48-4J Branch Connections for System Interchanges (Typical Schematics)..... 4

48-5A Ramp Design Speeds 4

48-5B Rate of Superelevation (Interchange Ramps) (8%) 4

48-5C Rate of Superelevation (Interchange Ramps) (6%) 4

48-5D Rate of Superelevation (Interchange Ramps) (4%) 4

48-6A Freeway Lane Drop (Typical Schematic)..... 4

48-6B Ramp/Continuous Frontage Road Intersection..... 4

48-6C Typical Access Control for a Diamond Interchange..... 4

48-6D Typical Access Control for a Partial Cloverleaf Interchange (With Frontage Road)4

48-6E Access Control at Ramp Terminals 4

CHAPTER FORTY-EIGHT..... 5

48-1.0 GENERAL..... 5

48-1.01 INDOT Procedures 5

48-1.02 Guidelines	5
48-1.03 New or Revised Access to the Interstate System	6
48-1.03(01) Applicability	6
48-1.03(02) Actions Requiring an IJ	7
48-1.03(03) Actions Not Requiring an IJ	8
48-1.03(04) Coordination with National Environmental Policy Act (NEPA) Requirements	9
48-1.03(05) General Steps in Revising or Adding Access to the Interstate System.....	9
48-1.03(06) Content of the IJ.....	11
48-1.03(07) FHWA Approval.....	16
48-1.04 Grade Separation Versus Interchange	18
48-2.0 INTERCHANGE TYPE SELECTION	19
48-2.01 General Evaluation	19
48-2.02 Types	20
48-2.02(01) Diamond.....	20
48-2.02(02) Single Point Interchange	21
48-2.02(03) Three-Level Diamond.....	22
48-2.02(04) Full Cloverleaves.....	23
48-2.02(05) Partial Cloverleaves.....	25
48-2.02(06) Three-Leg.....	26
48-2.02(07) Directional and Semi-Directional	26
48-3.0 TRAFFIC OPERATIONAL FACTORS.....	27
48-3.01 Basic Number of Lanes	27
48-3.02 Lane Balance	27
48-3.03 Route Continuity.....	28
48-3.04 Signing and Marking	28
48-3.05 Uniformity	29
48-3.06 Distance Between Successive Freeway/Ramp Junctions	29
48-3.07 Auxiliary Lanes	29
48-3.08 Lane Reductions	30
48-3.09 Safety Considerations	30
48-3.10 Capacity and Level of Service.....	31
48-3.11 Testing for Ease of Operation.....	32
48-4.0 FREEWAY/RAMP JUNCTIONS.....	32
48-4.01 Exit Ramps	32
48-4.01(01) Types of Exit Ramps.....	32
48-4.01(02) Taper Rates	33
48-4.01(03) Deceleration	33
48-4.01(04) Sight Distance	34
48-4.01(05) Superelevation.....	34
48-4.01(06) Cross Slope Rollover	35

48-4.01(07) Shoulders.....	35
48-4.01(08) Gore Area.....	35
48-4.02 Entrance Ramps.....	36
48-4.02(01) Types.....	37
48-4.02(02) Taper Rates.....	37
48-4.02(03) Acceleration.....	37
48-4.02(04) Sight Distance.....	39
48-4.02(05) Superelevation.....	39
48-4.02(06) Cross Slope Rollover.....	39
48-4.02(07) Shoulder Transitions.....	39
48-4.02(08) Gore Area.....	40
48-4.03 Continuous Auxiliary Lanes.....	40
48-4.04 Multi-Lane Terminals.....	40
48-4.05 Major Fork/Branch Connections.....	41
48-5.0 RAMP DESIGN.....	42
48-5.01 Design Speed.....	42
48-5.02 Cross Section.....	43
48-5.03 Horizontal Alignment.....	44
48-5.03(01) Theoretical Basis.....	44
48-5.03(02) General Controls.....	46
48-5.03(03) Freeway/Ramp Junctions.....	47
48-5.03(04) Ramp Proper (Directional Ramps).....	47
48-5.03(05) Ramp Proper (Loop Ramps).....	47
48-5.03(06) Ramp Terminus (Intersection Control).....	48
48-5.03(07) Ramp Terminus (Merge Control).....	48
48-5.04 Vertical Alignment.....	48
48-5.04(01) Grades.....	48
48-5.04(02) Vertical Curvature.....	49
48-5.05 Roadside Safety.....	49
48-6.0 OTHER INTERCHANGE DESIGN CONSIDERATIONS.....	49
48-6.01 General.....	50
48-6.02 Freeway Lane Drops.....	51
48-6.03 Collector-Distributor Roads.....	52
48-6.04 Frontage Roads.....	53
48-6.05 Ramp/Crossing Road Intersection.....	54
48-6.06 Access Control.....	55

LIST OF FIGURES

<u>Figure</u>	<u>Title</u>
<u>48-2A</u>	<u>Freeway Interchanges (Based on Functional Classification of Intersecting Facility)</u>
<u>48-2B</u>	<u>Diamond Interchange</u>
<u>48-2C</u>	<u>Single Point Urban Interchange</u>
<u>48-2D</u>	<u>Three-Level Diamond Interchange</u>
<u>48-2E</u>	<u>Full Cloverleafs</u>
<u>48-2F</u>	<u>Partial Cloverleaf Arrangements</u>
<u>48-2G</u>	<u>Three-Leg Interchanges</u>
<u>48-2H</u>	<u>Fully Directional Interchange</u>
<u>48-2 I</u>	<u>Semi-Directional Interchanges</u>
<u>48-3A</u>	<u>Typical Examples of Lane Balance</u>
<u>48-3B</u>	<u>Recommended Minimum Ramp Terminal Spacing</u>
<u>48-3D</u>	<u>Alternate Methods of Dropping Additional Lanes</u>
<u>48-4A</u>	<u>Typical Exit Ramp Types (Single Lane)</u>
<u>48-4B</u>	<u>Typical Gore Area Characteristics</u>
<u>48-4C</u>	<u>Typical Entrance Ramp Types (Single Lane)</u>
<u>48-4D</u>	<u>Minimum Acceleration Lengths for Entrance Terminals With Flat Grades of 2 % or Less</u>
<u>48-4E</u>	<u>Grade Adjustments for Acceleration (Passenger Cars)</u>
<u>48-4F</u>	<u>Lengths for Acceleration (200 lb/hp Truck)</u>
<u>48-4G</u>	<u>Multi-Lane Entrance Ramp (Service Interchanges)</u>
<u>48-4H</u>	<u>Multi-Lane Exit Ramp (Service Interchanges)</u>
<u>48-4 I</u>	<u>Major Forks for System Interchanges (Typical Schematics)</u>
<u>48-4J</u>	<u>Branch Connections for System Interchanges (Typical Schematics)</u>
<u>48-5A</u>	<u>Ramp Design Speeds</u>
<u>48-5B</u>	<u>Rate of Superelevation (Interchange Ramps) (8%)</u>
<u>48-5C</u>	<u>Rate of Superelevation (Interchange Ramps) (6%)</u>
<u>48-5D</u>	<u>Rate of Superelevation (Interchange Ramps) (4%)</u>
<u>48-6A</u>	<u>Freeway Lane Drop (Typical Schematic)</u>
<u>48-6B</u>	<u>Ramp/Continuous Frontage Road Intersection</u>
<u>48-6C</u>	<u>Typical Access Control for a Diamond Interchange</u>
<u>48-6D</u>	<u>Typical Access Control for a Partial Cloverleaf Interchange (With Frontage Road)</u>
<u>48-6E</u>	<u>Access Control at Ramp Terminals</u>

CHAPTER FORTY-EIGHT

INTERCHANGES

48-1.0 GENERAL

An interchange is a system of interconnecting roadways in conjunction with one or more grade separations that provides for the movement of traffic between two or more roadways on different levels.

48-1.01 INDOT Procedures

The Environment, Planning and Engineering Division's Engineering Assessment Section is generally responsible for determining the need for, location of and type of interchanges. This assessment is based on a consideration of several factors which are discussed in Sections 48-1.0 and 48-2.0. The designer is responsible for determining the layout and design of the interchange as discussed in Sections 48-3.0 through 48-6.0.

48-1.02 Guidelines

Although an interchange is a high-level compromise for intersection problems, its high cost and environmental impact require that an interchange be used only after careful consideration of its benefits. Because of the great variance in specific site conditions, INDOT has not adopted specific interchange warrants. When determining the need for an interchange or grade separation, the following should be considered:

1. Design Designation. Once it has been decided to provide a fully access-controlled facility, each intersecting highway must be terminated, rerouted, provided a grade separation or provided an interchange. The importance of the continuity of the crossing road and the feasibility of an alternative route will determine the need for a grade separation or interchange. An interchange should be provided on the basis of the anticipated demand for access to the minor road.

On facilities with partial control of access, intersections with public roads will be accommodated by an interchange or with an at-grade intersection; grade separations alone are not normally provided. Typically, an interchange will be selected for the higher-volume

intersecting roads. Therefore, on a facility with partial control of access, the decision to provide an interchange will be, in general, based on the criteria in Section 48-1.04.

2. Congestion. An interchange may be considered where the level of service (LOS) at an at-grade intersection is unacceptable, and the intersection cannot be redesigned at-grade to operate at an acceptable LOS. Although LOS criteria is the most tangible of any interchange guideline, The Department has not adopted any specific levels which, when exceeded, would demand an interchange. Even on facilities with partial control of access, the elimination of signalization contributes greatly to the improvement of flow.
3. Safety. The accident reduction benefits of an interchange should be considered at an existing at-grade intersection which has a high accident rate. The elimination of railroad-highway crossings should be considered in this factor. Section 48-3.08 provides additional information on various safety considerations relative to interchange selection.
4. Site Topography. At some sites the topography may be more adaptable to an interchange than an at-grade intersection.
5. Road-User Benefits. Interchanges significantly reduce the travel time when compared to at-grade intersections but may increase the travel distances. If an analysis reveals that road-user benefits over the service life of the interchange will exceed costs, then an interchange may be considered. For more information on road-user benefit analysis, see Chapter Fifty.
6. Traffic Volume. Interchanges should be considered at crossroads with heavy traffic volumes because elimination of conflicts greatly improves the movement of traffic.
7. Other Factors. Other factors, which need to be considered, include construction costs, right-of-way impacts and environmental concerns.

48-1.03 New or Revised Access to the Interstate System

48-1.03(01) Applicability

Each entrance or exit point to an Interstate route is considered to be an access point. For example, a conventional diamond interchange has four access points, two on-ramps and two off-ramps. Locked-gate access is defined as an access point, and is described in Section 48-1.03(02), Item 9.

Revised access to an Interstate route is considered to be a change in the existing essential form, even though the sheer number of access points does not change. For example, adding a loop on-ramp in concert with a collector-distributor (C-D) roadway linked with a downstream diagonal on ramp to an otherwise conventional diamond interchange, or changing a cloverleaf interchange into a fully directional interchange is considered to be a revised access. Lengthening or adding auxiliary lanes at at-grade ramp terminals with crossroads or ramp-proper lanes is not, nor is converting a single-lane off- or on-ramp to dual-lanes. This is clarified in Sections 48-1.03(02) and 48-1.03(03).

The design of new or revised access must comply with AASHTO's *A Policy on Geometric Design of Highways and Streets*, AASHTO's *A Policy on Design Standards – Interstate System*, and this *Manual*.

Work determined to consist of new or revised access to the existing Interstate System will require development by INDOT to FHWA of a formal Request for New or Revised Access to the Interstate System, commonly referred to as an Interstate Justification (IJ) Study Report. The IJ is a stand-alone document which constitutes a request from INDOT for FHWA approval of new or revised access. The document will demonstrate that reasonable care has been taken in addressing eight criteria described in the *Federal Register* of February 11, 1998, and Section 48-1.03(03), confirming that future traffic operations along the affected Interstate corridor will not be adversely affected by the proposed action. The entire Interstate System in the state is under jurisdiction of INDOT. Only the Department, and not a local public agency or private concern, may develop an IJ and submit it to FHWA for approval.

The requirement for an IJ and such FHWA approval applies only for non-tolled Interstate routes and Interstate toll roads where federal-aid funds have been expended or where the tolled sections have been added to the Interstate System under the requirements of 23 USC 139(a). Access to a non-Interstate freeway or to a new Interstate highway does not require an IJ. The Department has the authority to approve new or revised access to all other types of routes where federal-aid funds were used to acquire the access control. For this situation, the Department must obtain the value of the access from the appropriate property owner(s) and either credit the federal share under existing disposal requirements, or determine that the net proceeds can be handled in accordance with 23 USC 156. The Department may request FHWA advice or assistance on the acceptability of these types of new or revised access if desired.

48-1.03(02) Actions Requiring an IJ

The actions that require Department development and FHWA approval of an IJ are as follows:

1. establishing a new freeway-to-freeway (system) interchange;

2. major modification of a freeway-to-freeway interchange; e.g., adding new ramp(s), removing ramp(s) from service, significantly relocating tie-in points (terminals) on the freeway, or, where all movements are not currently accommodated, adding ramps to provide for all movements;
3. establishing a new or revised partial interchange of any form;
4. establishing a new freeway-to-non-freeway (service) interchange;
5. modification of an existing freeway-to-non-freeway (service) interchange, e.g., adding a new ramp, removing a ramp from service, significantly relocating tie-in points (terminals) on mainline freeway or crossroad, or adding or significantly altering collector-distributor (C-D) elements;
6. removal from service of select access points or ramps or an entire interchange;
7. changing the essential type of interchange, e.g., replace conventional diamond with partial cloverleaf;
8. changing the essential form of a ramp, e.g., directional, semi-directional, loop, or diagonal;
9. new or revised locked-gate access, or access via locked gates for privately or publicly employed personnel. Locked-gate access is limited to use by utility or Department personnel and not the general public; or
10. other forms of new or revised access not explicitly listed above, e.g., those rising to a level beyond incidental work.

48-1.03(03) Actions Not Requiring an IJ

The actions that do not require development of an IJ are as follows:

1. changing a single-lane freeway exit or entrance to a two-lane freeway exit or entrance;
2. widening a single-lane on- or off-ramp (ramp proper) to two or more lanes;
3. widening (adding auxiliary lanes to) an on- or off-ramp at its intersection with a crossroad (at-grade terminal) to provide two or more intersection approach lanes;

4. minor horizontal or vertical realignment of a ramp;
5. converting a taper-type on- or off-ramp to one of a parallel-type;
6. increasing the length of an on-ramp acceleration lane or an off-ramp deceleration lane;
7. addition of one or more continuous auxiliary lanes between two adjacent interchange ramps; or
8. other minor actions not explicitly listed above.

An analysis of traffic operation should typically be conducted. The Department should informally consult with the appropriate FHWA Transportation Engineer even if such project is not subject to FHWA oversight.

48-1.03(04) Coordination with National Environmental Policy Act (NEPA) Requirements

When a federal agency is required to make an approval action, regardless of the funding source, the NEPA process must be followed. Therefore, since FHWA approves from INDOT, a formal Request for New or Revised Access to the Interstate System (IJ analysis), the NEPA process must be followed when developing new or revised Interstate access. The NEPA process should proceed concurrently with development and analysis of (existing) Interstate access alternatives to ensure that all decision-making regarding all viable alternatives that are expected to be acceptable by FHWA from a traffic-operations standpoint are analyzed and adequately considered. FHWA final IJ approval can only be obtained after completion of the NEPA process. The intention is to eliminate early alternatives that would not be acceptable from a transportation and safety operations standpoint. The final decision on a preferred and selected alternative is to be made as part of the NEPA process.

48-1.03(05) General Steps in Revising or Adding Access to the Interstate System

There are five major steps that normally should be followed for alternatives' development of IJ development for a more-complex proposed new or revised access to the Interstate System. These proposed actions usually require an Environmental Impact Statement (EIS) or an Environmental Assessment (EA) to complete the NEPA process. The first two steps effectively take place as a forerunner to the formal IJ process. Not all of these decision points are necessary for IJ development for a less-complex proposed new or revised access. In coordination with the

appropriate FHWA Project Management Team Leader, some or all of the early decision points may be determined to be unnecessary and that only final approval should be requested. The basic steps, or decision points, are as follows:

1. Development of Alternatives. At the start of alternatives' development for actions that may ultimately require IJ preparation and approval, the Department will meet with FHWA to identify any special process and operational requirements. During the Engineering Assessment phase and early in the NEPA process, one or more alternative functional designs should be examined from primary aspects of traffic operation, safety, and cost-effectiveness in concert with overall social, economic, and environmental consequences. Alternatives that would not function adequately from a safety or traffic operations standpoint should be eliminated. During the NEPA alternatives'-screening process, appropriate intensity-of-alternatives' development should be carried out, along with analysis and coordination with other parties having a stake in the screening and ultimate access decision. The Production Management Division's Environmental Policy Team oversees development of IJ activities. The appropriate FHWA Project Management Team will serve as the Department's point of contact for this process of developing and screening alternatives. The Team's Transportation Engineer will represent FHWA in providing opinion and review of alternatives from a transportation-operations standpoint.
2. Concept Approval. A letter requesting concept approval of a new or revised access element will be submitted to FHWA once a single alternative has been identified as the conditionally recommended course of action emerging from the access concept's development phase and ongoing NEPA process. This may occur either before the Draft EIS is approved or before the final EIS, EA, or Categorical Exclusion (CE) is approved. If appropriate, the FHWA Project Management Team Leader will respond in writing within two weeks indicating the acceptability in concept of the recommended alternative and allow for the completion of the appropriate NEPA documentation and preparation of the formal IJ request. This will represent FHWA's Concept Approval, and is FHWA's opinion with respect to the engineering and operational acceptability of the recommend alternative based on the information available at that time. FHWA's Concept Approval is given with the understanding that the proposal will be that which is reflected in the final NEPA document, either CE, Finding of No Significant Impact (FONSI), or Record of Decision (ROD).
3. Draft IJ Report Development. The Department will initiate a meeting with FHWA to determine the scope of assessment unique to the particular new or revised access element. The Department will then prepare the draft document, focusing on the eight points of the *Federal Register* of February 11, 1998. The draft IJ will be submitted to the FHWA for comments.

4. Final IJ Submittal. Upon written reply/comments on the draft IJ from FHWA, the necessary revisions should be made. The Department may meet with FHWA to resolve significant issues, and/or upon request from FHWA. The final IJ should not be forwarded to FHWA until the preferred alternative within the context of the NEPA process is identified. By cover letter with the final IJ, the Department will request from FHWA a determination of engineering and operational acceptability of the new or revised access. The letter will also include the status of the NEPA evaluation.
5. Provisional and Final IJ Approval. FHWA will respond in writing within four weeks to INDOT's formal request for approval of new or revised access, effectively approving the final IJ. The letter from FHWA will indicate approval or denial of the request. It is understood that approval of the IJ proposal is provisional, if at that stage the NEPA process has not been fully executed. Upon approval of the final environmental document (CE, FONSI, or ROD), FHWA will issue the Department final IJ approval in writing.

48-1.03(06) Content of the IJ

The Request for New or Revised Access to the Interstate System, or IJ, must address the eight criteria outlined in the *Federal Register* of February 11, 1998, and described below. These criteria will be the focus of attention in the IJ. The IJ must directly respond to the eight criteria, in the order shown below. Other background information may be presented to supplement that core element. A clear description of the proposed new or revised access should be presented, generally in narrative form directing the reader to sketch-plan drawings. All relevant notes, summary printouts, and/or electronic input/output files of traffic operations analysis should be appended to the IJ document, be they from HCM / HCS, or other method of analysis.

Background information should be included that may help explain or support the proposal, including a description of the influence of the area's regional transportation network, and any known areas of concern, e.g., environmental, safety, related projects, and long-range transportation plans. A crash analysis summary must be included. The analysis must include a summary of crash data for the previous three-year period. There must be a discussion of the anticipated safety impact the access change will have on the Interstate-route mainline and interchange ramps. The analysis must demonstrate that the access change will not compromise safety. Any necessary design exceptions should desirably be identified. In addition, the total estimated cost of the project should be provided. A complex urban project may require a conceptual-stage signing plan if determined to be necessary by FHWA and the Department.

The following lists and clarifies the criteria shown in the *Federal Register* of February 11, 1998. For each of the eight criteria, the first paragraph restates the language in the *Federal Register*, unedited. The subsequent paragraphs serve to clarify the core statement.

1. Existing Facilities. *The existing interchanges and/or local roads and streets in the corridor can neither provide the necessary access nor be improved to satisfactorily accommodate the design year traffic demands while at the same time providing the access intended by the proposal.*

The IJ should demonstrate that an access point is needed for regional traffic needs and not to solve local transportation needs. It is of utmost importance to maintain the integrity and primary function of the Interstate System. The Interstate facility should not be permitted to become part of the local circulation system but should be maintained as the main regional and inter-state highway it was intended to be. All reasonable measures should be made to provide local access and mobility by means of the non-Interstate network.

Existing or possible future roads or streets in the vicinity of the Interstate facility should be evaluated or considered for use as connections to existing adjacent interchange ramps, in lieu of adding a new interchange or ramp(s).

2. Transportation System Management (TSM). *All reasonable alternatives for design options, location, and transportation system management type improvements (such as ramp metering, mass transit, and HOV facilities) have been assessed and provided for if currently justified, or provisions are included for accommodating such facilities if a future need is identified.*

All TSM strategies, including those that involve improvements to the existing non-Interstate roads and streets, should be fully explored in lieu of new or revised access to the Interstate system.

3. Access Connections and Design. *The proposed access connects to a public road only and will provide for all traffic movements, except in only the most extreme circumstances. Less than full interchanges for special purpose access for transit vehicles, for HOVs, or into park and ride lots may be considered on a case-by-case basis. The proposed access will be designed to meet or exceed current standards for federal-aid projects on the Interstate System.*

Except in the most extreme circumstances, all interchanges should provide for all basic movements. Partial interchanges are generally unacceptable, in part because they have undesirable operational characteristics. Private-road access is not permitted on the Interstate System.

4. Transportation Land Use Plans. *The proposal considers and is consistent with local and regional land use and transportation plans. Prior to final approval, all requests for new*

or revised access must be consistent with the metropolitan and/or statewide transportation plan, as appropriate, the applicable provisions of 23 CFR 450 and transportation conformity requirements of 40 CFR 51 and 93.

Coordination with strategic, long-term transportation plans should be ensured, so as not to have fragmented consideration of revised or added access. The IJ should include a discussion as to how the proposal fits into the overall transportation plans for the area and, if it is an addition to the current plans for the area, how it affects the current plans. The IJ proposal does not have to be included in official transportation plans or approved by metropolitan planning organizations (MPOs) or similar organizations prior to submittal to FHWA. However, if the project is within an MPO area, coordination with the MPO must occur. All such coordination must be completed before FHWA approval of the IJ. This should form part of the normal project development process. The expectation here is that any proposal is considered in view of currently known plans for transportation facilities or land use planning.

5. *Comprehensive Interstate Network Study. In areas where the potential exists for future multiple interchange additions, all requests for new or revised access are supported by a comprehensive Interstate network study with recommendations that address all proposed and desired access within the context of a long-term plan.*

To the extent practicable, the Department will program, and thus allow coordinated analysis and project development, of logical Interstate segments which may include multiple access sites (interchanges).

6. *Coordination with Transportation System Improvements. The request for a new or revised access generated by new or expanded development demonstrates appropriate coordination between the development and related or otherwise required transportation system improvements.*

It is incumbent upon the Department and FHWA to ensure that the Interstate System is preserved and improved in an orderly and coordinated manner to serve the public and maintain the essential function of this most important network of national highways. Therefore, if private development is the impetus behind the need for access, it is necessary to coordinate efforts with the private party in order to develop the access to achieve mutual benefits with no safety or operational adverse impacts on Interstate-route users.

7. *Status of Planning and NEPA. The request for new or revised access contains information relative to the planning requirements and the status of the environmental processing of the proposal.*

Information should be confirmed and reported relative to the status of the planning and NEPA processes with regard to the access request.

8. *Operational Analysis. The proposed access point does not have a significant adverse impact on the safety and operation of the Interstate facility based on an analysis of current and future traffic. The operational analysis for existing conditions shall, particularly in urbanized areas, include an analysis of sections of Interstate to and including at least the first adjacent existing or proposed interchange on each side. Crossroads and other roads and streets shall be included in the analysis to the extent necessary to assure their ability to collect and distribute traffic to and from the interchange with the new or revised access points.*

Sufficient operational analyses should be made to determine the impact of the revised or new access on the Interstate-route operation. The Transportation Research Board's *Highway Capacity Manual (HCM)* analysis procedures should be used. Analysis based on other methodologies is not acceptable. The *HCM*'s companion software, HCS, may be used. Other software tools that precisely replicate *HCM* methodologies may be used. Analysis by means of other (software) models that do not precisely employ *HCM* equations and logic may be presented but only as supplementary information.

The operational analysis should be extended as far along the mainline and should include adjacent downstream interchanges as necessary to establish the extent and scope of the impacts. This could be critical in an urban area with many interchanges spaced at less than 1 mi apart. As a minimum, the operational impact on the mainline Interstate route between the proposed new or revised access and immediately adjacent existing downstream interchanges on either side must be analyzed. The exact adjacent interchanges to be analyzed will be determined jointly by FHWA and the Department. Crossroad analysis is always required at the subject (core) interchange, between, through, and outside of ramp terminals on the crossroad. Analysis of the crossroads of the adjacent downstream interchanges is normally not required in an IJ, unless circumstances dictate otherwise.

Appropriate, sanctioned traffic data provided by the Program Development Division's Traffic Statistics Unit should be used as the basis for operational analysis for the IJ process. The traffic counts and projections should be approved by the Department, developed using acceptable industry and agency standards.

- a. **Drawings.** A dimensioned drawing(s) of preferred scale 1:2000 to 1:4000 should be provided as an attachment to the IJ document. The drawing(s) should show the functional elements of the existing and proposed conditions, including, as applicable, project limits, adjacent interchange(s) along the freeway, adjacent intersections along the crossroad, ramps to be added, ramps to be removed,

relocation of ramp gores, configuration, travel lanes, auxiliary lanes, ramp radii, acceleration and deceleration lanes, taper lengths, freeway ramp terminals, and C-D roadways.

A drawing or series of drawings should be provided showing the traffic volumes for all through and turning movements, as well as data on C-D roadways, local service roads, and origin-destination (O-D) travel particularly for weaving movements. The base-year or open-to-traffic-year AADTs should be identified for the mainline, crossroads, ramps, and intersections. The design year AADTs, morning and evening DHVs, and trucks percentages for each movement should be included.

- b. Highway Capacity Analysis. A narrative of the assumptions used and reasons for any changes in the software default values should be included. Results of operational analysis, in the form of service levels for each element of the Interstate-route access facility, and for multiple years and periods of the day, should be clearly presented on a drawing at a scale of 1:2000 to 1:4000.

The summary results, typically in levels-of-service (LOS), should be provided for each element, e.g., weaving, basic freeway ramp merge and diverge, ramp proper, at-grade signalized and unsignalized ramp terminals (intersections), crossroad arterial and its intersections in the access influence area for existing (no-build) and proposed (build) conditions in the base year or open-to-traffic year, and in the design year for morning and evening peak periods.

Queue analysis should be provided as part of the traffic operational analysis for those points where significant queuing might be expected, such as at ramp junctions with the crossroad and at major intersections on the crossroad adjacent to at-grade ramp terminals.

All highway capacity and operations calculations must be included in an Appendix to the IJ. If the nature of the project entails a level of traffic operations analysis generating inordinately large volumes of output, the bulk of the hand calculations and printout of the HCS or other software tools may be provided in electronic format (on a compact disc) if desired, rather than on a hardcopy. However, at least 10% of the points checked for LOS must be in hardcopy format. In this case, a variety of points should be selected for the sample to be printed in paper format, especially critical locations. In addition, a hardcopy of all analyzed weaving areas must be included in the Appendix.

Any adjacent interchange, or intersection adjacent to the core access point/interchange, which is found to have a LOS below D for any of its elements,

must be clearly identified. The IJ must contain a discussion of the impact this will have, if any, on the new or revised interchange(s) and Interstate-route mainline. Potential mitigation measures to alleviate any adverse impacts to the core access point/interchange must be described to at least a concept level. An alternative would be to describe the mitigation measures in the IJ transmittal letter to FHWA or in a separate correspondence with FHWA.

- c. **Crossroad Highway Capacity Analysis.** Intersections at ramp terminals and along crossroads must be analyzed to determine if they could have a negative impact on Interstate-route operations. Basically, the crossroads must be capable of collecting and distributing traffic to and from the Interstate route.

All stop-controlled and signalized intersections within 1200 ft of the ramp terminal must be analyzed for traffic operation. It may be necessary to analyze intersections on the crossroad beyond 1200 ft. In some circumstances it may be beneficial to assess traffic operational conditions 2000 ft or 2500 ft beyond the ramp limits. The exact intersections to be analyzed along the crossroad will be determined jointly by FHWA and the Department.

If the analysis shows that any adjacent intersection will operate at LOS of E or F in the design year, a LOS analysis must be done to determine when the adjacent intersection becomes unacceptable, i.e., below LOS of D.

Any intersection that is shown to have a LOS of E or F in the open-to-traffic year or 7 years beyond must be investigated to at least a concept level to determine what needs to be done to make it operate at LOS of D or better in the design year, e.g., add lanes. In addition, it will be necessary to determine whether the failure is the result of normal traffic growth or the result of the interchange access change. The Department and the responsible local public agency will determine who will be responsible for any necessary intersection improvements outside of the interchange area (to adjacent intersections) and when they will be accomplished. The Department will notify FHWA of the action to be taken either in the IJ, the IJ transmittal letter, or by separate correspondence.

Those intersections which are shown to have a LOS of E or F between years 7 and 20 will be monitored for needed improvements. The IJ, the IJ transmittal letter, or separate correspondence must identify who will be responsible for this activity.

Approval is required from the FHWA Washington, D.C., Headquarters office (HQ) for the major types of new or revised access requests listed below. Two copies of the Final IJ must be sent to the FHWA Indiana Division office for those actions of a significant nature requiring coordination with HQ. Advance coordination with HQ may be necessary for certain complex or controversial projects. For these situations, the Department should coordinate directly with the Division office, specifically, the appropriate Transportation Engineer.

1. FHWA Approval by HQ. HQ approval is required for the types of Interstate System new or revised access as follows:
 - a. establishing a new freeway-to-freeway (system) interchange;
 - b. major modification of a freeway-to-freeway interchange;
 - c. establishing a new partial interchange of any form; or
 - d. establishing a new freeway-to-non-freeway (service) interchange in a Transportation Management Area (TMA). A TMA is defined as an urbanized area with a current population of more than 200,000 as determined by the most recent decennial census, or as an area for which the TMA designation is requested by the governor and the MPO or affected local officials, and officially designated by the Administrators of the FHWA and the Federal Trade Administration.

2. FHWA Approval by Division Office. One copy of the Final IJ must be sent to the Division office for approval for the types of Interstate system new or revised access as follows:
 - a. establishing a new freeway-to-non-freeway interchange not located in a TMA;
 - b. modification of an existing freeway-to-non-freeway interchange configuration;
 - c. establishing locked-gate access; or
 - d. removal from service of ramps or interchanges.

FHWA approval of an IJ is valid for 10 years from the date of the letter granting its final approval. If 10 years have expired before proceeding with construction of the new or revised access, it will be necessary to re-evaluate the IJ. This involves obtaining current traffic data for that time, projecting such data out to 20 years and determining if the originally approved IJ will still provide acceptable levels of service for the new design year. Basically, it will be necessary to repeat the procedures outlined herein and produce a revised IJ for FHWA approval.

48-1.04 Grade Separation Versus Interchange

Once it has been determined to provide a grade-separated crossing, the need for access between the two roadways with an interchange must be determined. The following lists several guidelines to consider when determining the need for an interchange:

1. Functional Classification. Interchanges should be provided at all freeway-to-freeway crossings. On fully access-controlled facilities, interchanges should be provided with all major highways, unless this is determined inappropriate for other reasons. Interchanges to other highways should be provided if practical.
2. Site Conditions. Site conditions which may be adaptable to a grade separation may not always be conducive to an interchange. Restricted right-of-way, environmental concerns, rugged topography, etc., may restrict the practical use of an interchange.
3. Interchange Spacing. When interchanges are spaced farther apart, freeway operations are improved. Spacing of urban interchanges between interchange crossroads should not be less than 1 mile. This should allow for adequate distance for an entering driver to adjust to the freeway environment, to allow for proper weaving maneuvers between entrance and exit ramps, and to allow for adequate advance and turnoff signing. In urban areas, a spacing of less than 1 mile may be developed by grade-separated ramps or by collector-distributor roads. In rural areas, interchanges should not be spaced less than 3 mi apart on the Interstate system or 2 mi on other systems.
4. Access. Interchanges may be required in areas where access availability from other sources is limited, and the freeway is the only facility that can practically serve the area.
5. Operations. Grade separated facilities without ramps will require all drivers desiring to turn onto the cross road to use other locations to make their desired moves. This will often improve the operations of the major facility by concentrating the turning movements at a few strategically placed locations. However, undue concentration of the turning movements at one location may overload the capacity of the exit or entrance facility.
6. Overpass Versus Underpass Roadways. A detailed study should be made at each proposed highway grade separation to determine whether the main road should be carried over or under the crossroad. Often the decision is based on features such as topography or functional classification.

48-2.0 INTERCHANGE TYPE SELECTION

48-2.01 General Evaluation

Section 48-2.02 presents the interchange types which may be used at a given site. The Environment, Planning and Engineering Division's Environmental Services Section normally determines the type of interchange for the site. Typically, this Section will evaluate several types for potential application. Each type should be evaluated considering:

1. compatibility with the surrounding highway system;
2. route continuity;
3. level of service for each interchange element (e.g., freeway/ramp junction, ramp proper);
4. operational characteristics (single versus double exits, weaving, signing);
5. road user impacts (travel distance and time, safety, convenience and comfort);
6. driver expectancy (e.g, exits and entrances to the right);
7. geometric design;
8. construction and maintenance costs;
9. potential for stage construction;
10. right-of-way impacts and availability;
11. environmental impacts; and
12. potential growth of surrounding area.

In addition, three other overall factors also influence the selection of an interchange type:

1. Basic Types. A freeway interchange will be one of two basic types. A "systems" interchange will connect a freeway to a freeway; a "service" interchange will connect a freeway to a lesser facility.
2. Urban/Rural. In rural areas where interchanges occur relatively infrequently, the design can normally be selected strictly on the basis of service demand and analyzed as a separate unit. In urban areas where restricted right-of-way and close spacing of interchanges are common, the type selection and design of the interchange may be severely limited. The operational characteristics of the intersecting road and nearby interchanges will be major influences on the design of an urban interchange.
3. Movements. All interchanges should provide for all movements, even when the anticipated turning volume is low. An omitted maneuver may be a point of confusion to those drivers searching for the exit or entrance. In addition, unanticipated future developments may increase the demand for that maneuver.

Figure 48-2A presents general guidance for the types of interchanges that are adaptable to freeways based on the functional classification of the intersecting facilities in rural, suburban or urban environments. At other than a freeway-to-freeway intersection, the choice of interchange will likely be limited to a cloverleaf or a diamond or a variation thereof.

48-2.02 Types

This section describes the basic types of interchanges. Each interchange must be custom-designed to fit the individual site considerations. The final design may be a minor or major modification of one of the basic types or may be a combination of two or more basic types.

48-2.02(01) Diamond

The diamond is the simplest and perhaps the most common type of interchange. One-way diagonal ramps are provided in each quadrant with two at-grade intersections provided at the minor road. If these two intersections can be properly designed, the diamond is usually the best choice of interchange where the intersecting road is not access controlled. Figure 48-2B illustrates a schematic of a typical diamond interchange. Some of its advantages and disadvantages include the following:

1. Advantages.
 - a. All exits from the mainline are made before reaching the crossroad structure. This conforms to driver expectancy and therefore minimizes confusion.
 - b. All traffic can enter and exit the mainline at relatively high speeds. Adequate sight distance can usually be provided, and the operational maneuvers are normally uncomplicated.
 - c. Relatively little right-of-way is required.
 - d. Left-turning maneuvers require little extra travel distance.
 - e. The diamond configuration easily allows modifications to provide greater ramp capacity, if needed in the future. A spread diamond interchange has the potential for conversion to a cloverleaf.
 - f. Their common usage has resulted in a high degree of driver familiarity.

2. Disadvantages.
 - a. There are potential operational problems with the two at-grade intersections at the minor road. Signalization may be needed if the crossroad carries moderate to large traffic volumes. While a single-lane ramp may adequately serve traffic from the roadway, it may have to be widened to 2 or 3 lanes or be channelized for storage near the crossroad, in order to provide the required capacity.
 - b. There is greater potential than, for example, a full cloverleaf for wrong-way entry onto the ramps. A median should be provided on the crossroad to facilitate proper channelization. In most cases, additional signing to minimize improper use of the ramps should be included in the interchange design.
 - c. Sufficient intersection sight distance should be provided at the minor roads.

48-2.02(02) Single Point Interchange

Figure 48-2C illustrates a special type of diamond interchange - a single point interchange. With this interchange, all legs of the interchange meet at a single point. Some of the advantages and disadvantages of this interchange include the following:

1. Advantages.
 - a. The right-turn movements are typically free-flow movements. The design of free-flow right turns should include an additional lane on the cross street beginning at the right-turn lane for at least 200 ft before being merged. Free-flow right turns from the exit ramp to an arterial crossroad are not desirable where the nearest intersection on the crossroad is within 500 ft, because of weaving.
 - b. It can significantly increase the interchange capacity. This arrangement can alleviate the operational problems of having two closely spaced at-grade intersections on the minor road. In particular, it overcomes the left-turning lane storage problem for drivers wishing to enter the freeway.
 - c. It reduces cross-street delays.
 - d. It only requires one signal instead of two at a typical diamond.
 - e. It reduces right-of-way needs.

- f. It can be used in rural areas where use of adjacent right of way is not desired due to environmental or other constraints.
2. Disadvantages.
 - a. Channelization design must be carefully considered to minimize driver confusion and the likelihood of wrong-way maneuvers. To provide positive guidance, at a minimum, dashed lines of 2 ft length should be placed through the intersection.
 - b. There is a significantly wider pavement area for pedestrians to cross the ramps. Preferably, the design should provide for pedestrians to cross the minor roadway at adjacent intersections, instead of the ramp terminal intersection.
 - c. Because of wide pavement areas, it requires longer signal clearance intervals.
 - d. It is difficult to accommodate frontage roads.
 - e. It has a higher construction cost than the typical diamond because of the need for a larger structure. However, this is often offset by the reduced right-of-way cost.
 - f. The design process becomes more difficult if the skew angle of the interchanging roadways approaches 30 deg.
 - g. It is difficult to add capacity in the future.

48-2.02(03) Three-Level Diamond

Figure 48-2D illustrates a special type of diamond interchange called a “three-level” diamond. With this interchange, all of the at-grade intersections are on a separate level than the two mainlines. Some advantages and disadvantages of this interchange type include the following:

1. Advantages.
 - a. It can handle high traffic volumes.
 - b. At-grade intersections are removed from both mainlines, thereby significantly increasing the capacity of the intersection.

- c. It uses less right-of-way than loop ramps.
 - d. One-way frontage roads can be easily incorporated into the interchange configuration.
2. Disadvantages.
- a. To make a left turn, a driver needs to pass through three at-grade intersections and/or traffic signals.
 - b. The additional structures result in higher construction costs.

48-2.02(04) Full Cloverleafs

Cloverleaf interchanges are used at 4-leg intersections and employ loop ramps to accommodate left-turn movements. Loops may be provided in any number of quadrants. Full cloverleaf interchanges are those with loops in all four quadrants; all others are partial cloverleafs.

Where two access-controlled highways intersect, a full cloverleaf is the minimum type of interchange design that will suffice. However, cloverleafs introduce several undesirable operational features such as the double exits and entrances from the mainline, the weaving between entering and exiting vehicles with the mainline traffic and, when compared to directional interchanges, the additional travel time and distance for left-turning vehicles. Therefore, a collector-distributor (C-D) road should be considered with a full cloverleaf, or a fully directional interchange should be provided. Figure 48-2E provides typical examples of full cloverleafs with and without C-D roads. See Section 48-6.03 for a discussion on C-D roads.

Operational experience with full-cloverleaf interchanges has yielded several conclusions on their design. Subject to a detailed analysis on a site-by-site basis, the following generally characterize the design of cloverleafs:

1. Design Speed Impacts. For an increase in design speed, there will be an increase in:
 - a. travel distance,
 - b. required right-of-way, and
 - c. travel time.
2. Loop Radii. Considering all factors, loops can be practically designed for approximate radii of 180 to 250-ft. The smaller radii are normally used in urban areas while the larger radii are typically used in rural areas.

3. Loop Geometry. Circular curve loop ramps are the most desirable geometrically because speeds and travel paths tend to be more constant and uniform.
4. Loop Capacity. Expected design capacities for single-lane loops range from 800 to 1200 vph and, for 2-lane loops, 1000 to 2000 vph. The higher figures are generally only achievable where the design speed is 30 mph or higher and few trucks use the loop.
5. Weaving Volumes. An auxiliary lane is typically provided between successive entrance/exit loops within the interior of a cloverleaf interchange. This produces a weaving section between the mainline and entering/exiting traffic. When the total volume on the two successive ramps reaches approximately 1000 vph, interference increases rapidly with a resulting reduction of the through traffic speed. At these weaving volume levels, a collector-distributor road should be considered.
6. Weaving Lengths. The minimum weaving length between the exit and entrance gores of loops on new cloverleaf interchanges without C-D roads or those undergoing major reconstruction should be at least 1000-ft or the distance determined by a capacity analysis, whichever is greater.
7. Advantages and Disadvantages. Some of the advantages and disadvantages of full cloverleaves include the following:
 - a. Advantages.
 - (1) Full cloverleaves are intended to eliminate all vehicular stops through the use of merges.
 - (2) Full cloverleaves eliminate all at-grade intersections and, therefore, eliminate left turns.
 - (3) Where right-of-way is reasonably inexpensive and adverse impacts are minimal, full cloverleaves may be a practical option.
 - b. Disadvantages.
 - (1) Full cloverleaves require more right-of-way and are more expensive than diamonds.
 - (2) The loops in cloverleaves result in a greater travel distance for left-turning vehicles than do diamonds, and the loops operate at lower speeds.

- (3) Half the exits and entrances are located beyond the crossroad structure, which does not conform to driver expectancy.
- (4) Full cloverleafs may introduce signing problems.
- (5) Full cloverleafs result in weaving sections. If the sum of traffic counts on two adjoining loops approaches 1,000 vehicles per hour, interference mounts rapidly, which results in a reduction of speed of through traffic. Consideration should be given to adding a collector-distributor road. The use of acceleration- or deceleration lanes is an alternative to collector-distributor roads.
- (6) Generally, ramps at diamond interchanges can be easily widened to increase capacity; while, two-lane loop ramps, on the other hand, require at least two additional lanes (one on each side) through the separation structure, longer weaving distances and larger loop radii to operate.
- (7) Pedestrian movements along cross streets are difficult to safely accommodate at cloverleaf interchanges.
- (8) A loop rarely operates with more than a single line of vehicles, and thus has a design capacity of 800 to 1,200 vehicles per hour.

48-2.02(05) Partial Cloverleafs

Partial cloverleaf interchanges are those with loops in one, two or three quadrants. They are appropriate where right-of-way restrictions preclude ramps in one or more quadrants. They are also advantageous where a left-turn movement can be provided onto the major road by a loop without the immediate presence of an entrance loop from the minor road. Figure 48-2F illustrates several examples of partial cloverleafs. In “B” and “C,” both left-turn movements onto the major road are provided by loops, a distinct preference.

Interchange ramps in only one quadrant have application for an intersection of roadways with low traffic volumes and minimal truck traffic. Where a grade separation is provided due to topography, and truck volumes don't justify the separation, a single two-way divided ramp of near minimum design usually will suffice.

Ramps should be arranged so that the entrance and exit movements create the least impediment to traffic flow on the major highway. The ramp arrangement should enable major turning movements to be made by right-turn exits and entrances.

Several of the advantages and disadvantages listed for full cloverleaves also apply to partial cloverleaves (e.g., geometric restriction of loops). Some specific advantages of partial cloverleaves include the following:

1. Depending upon site conditions, partial cloverleaves may offer the opportunity to increase weaving distances.
2. Partial cloverleaves are often appropriate where one or more quadrants present adverse right-of-way and/or terrain problems.
3. Partial cloverleaves may reduce the number of left-turn movements when compared to a diamond interchange.
4. Partial cloverleaf designs with loops in opposite quadrants are very desirable because they eliminate the weaving problem associated with full cloverleaf design.

48-2.02(06) Three-Leg

Three-leg interchanges, also known as “T” or “Y” interchanges, are provided at intersections with three legs. Figure 48-2G illustrates examples of 3-leg interchanges with several methods of providing the turning movements. See the *AASHTO Policy on Geometric Design of Highways and Streets* for additional variations of the three-leg interchange. The trumpet type is shown in (A) where three of the turning movements are accommodated with direct or semi-direct ramps and one movement by a loop ramp. In general, the semi-direct ramp should favor the heavier left-turn movement and the loop the lighter volume. Where both left-turning movements are fairly heavy, the design in (B) may be suitable. A fully directional interchange (C) is appropriate when all turning volumes are heavy, or the intersection is between two access-controlled highways. This would be the most costly type because of the necessary multiple structures. A three-leg interchange should only be considered when future expansion in the unused quadrant is either impossible or highly unlikely. They are very difficult to expand or modify in the future.

48-2.02(07) Directional and Semi-Directional

The following definitions apply to directional and semi-directional interchanges.

1. Directional Ramp. A ramp that does not deviate greatly from the intended direction of travel (see Figure 48-2H).

2. Semi-Directional Ramp. A ramp that is indirect in alignment, yet more direct than loops (see Figure 48-2 I).
3. Fully Directional Interchange. An interchange where all left-turn movements are provided by directional ramps (see Figure 48-2H).
4. Semi-Directional Interchange. An interchange where one or more left-turn movements are provided by semi-directional ramps, even if the minor left-turn movements are accommodated by loops (see Figure 48-2 I).

Directional or semi-directional ramps are used for heavy left-turn movements to reduce travel distance, to increase speed and capacity and to eliminate weaving. These types of connections allow an interchange to operate at a better level of service than is possible with cloverleaf interchanges. Left-hand exits and entrances may violate driver expectancy and, therefore, should be avoided.

Directional or semi-directional interchanges are most often warranted in urban areas at freeway-to-freeway or freeway-to-arterial intersections. They require less right-of-way than cloverleaf interchanges. A fully directional interchange provides the highest possible capacity and level of service, but it is extremely costly to build because of the multiple-level structure required. Interchanges involving two freeways will almost always require directional layouts.

48-3.0 TRAFFIC OPERATIONAL FACTORS

48-3.01 Basic Number of Lanes

The basic number of lanes is the minimum number of lanes designated and maintained over a significant length of a route based on the overall operational needs of that section. The number of lanes should remain constant over significant distances. For example, a lane should not be dropped at the exit of a diamond interchange and then added at the downstream entrance simply because the traffic volume between the exit and entrance drops significantly. Likewise, a basic lane should not be dropped between closely spaced interchanges simply because the estimated traffic volume in that short section of highway does not warrant the higher number of lanes.

48-3.02 Lane Balance

Lane balance refers to certain principles which apply at freeway exits and entrances as follows:

1. Exits. At exits the number of approach lanes on the highway should equal the sum of the number of mainline lanes beyond the exit plus the number of exiting lanes minus one. An exception to this principle would be at cloverleaf loop ramp exits which follow a loop ramp entrance or at exits between closely spaced interchanges (i.e., interchanges where the distance between the end of the taper of the entrance terminal and the beginning of the taper of the exit terminal is less than 1500-ft and a continuous auxiliary lane between the terminals is being used). In these cases, the auxiliary lane may be dropped in a single-lane exit with the number of lanes on the approach roadway being equal to the number of through lanes beyond the exit plus the lane on the exit.
2. Entrances. At entrances the number of lanes beyond the merging of the two traffic streams should be not less than the sum of the approaching lanes minus one. It may be equal to the number of traffic lanes on the merging roadway.
3. Traveled Way. The traveled way width of the highway should not be reduced by more than one traffic lane at a time.

For example, dropping two lanes at a 2-lane exit ramp would violate the principle of lane balance. One lane should provide the option of remaining on the freeway. Lane balance would also prohibit immediately merging both lanes of a 2-lane entrance ramp into a highway mainline without the addition of at least one additional lane beyond the entrance ramp. Figure 48-3B illustrates how to coordinate lane balance and the basic number of lanes at an interchange. Figure 48-3A illustrates how to achieve lane balance at the merging and diverging points of branch connections.

48-3.03 Route Continuity

All highways with interchanges are designated by route number. Desirably, the through driver should be provided a continuous numbered route on which changing lanes is not necessary to continue on the through route. Route continuity is consistent with driver expectancy, simplifies signing and reduces the decision demands on the driver. Interchange configurations should not necessarily favor the heavier traffic movement, but rather, the through route.

48-3.04 Signing and Marking

Proper interchange operations depend partially on the compatibility between its geometric design and the traffic control devices at the interchange. The proper application of signs and pavement markings will increase the clarity of paths to be followed, safety and operational efficiency. The

logistics of signing along a highway segment will also impact the minimum acceptable spacing between adjacent interchanges. The Design Division's Specialty Project Group will determine the use of traffic control devices at interchanges.

48-3.05 Uniformity

To the extent practical, all interchanges along a freeway should be reasonably uniform in geometric layout and appearance. Except for highly specialized situations, all entrance- and exit ramps should be to the right.

48-3.06 Distance Between Successive Freeway/Ramp Junctions

Especially in urban areas, successive freeway/ramp junctions frequently may need to be placed relatively close to each other. The distance between junctions should provide for vehicular maneuvering, signing and capacity. The ramp-pair combinations are entrance followed by entrance (EN-EN), exit followed by exit (EX-EX), exit followed by entrance (EX-EN), entrance followed by exit (EN-EX). The final decision on the spacing between freeway/ramp junctions will be based on the level-of-service criteria and on the detailed capacity methodology in the *Highway Capacity Manual*.

48-3.07 Auxiliary Lanes

As applied to interchange design, auxiliary lanes are most often used to comply with the principle of lane balance, accommodate speed change, increase capacity, accommodate weaving, or accommodate entering and exiting vehicles. An auxiliary lane may be dropped at an exit if properly signed and designed. The following statements apply to the use of an auxiliary lane within or near interchanges:

1. Within Interchange. Figure 48-3D provides the basic schematics of alternative designs for adding and dropping auxiliary lanes within interchanges. The selected design will depend upon traffic volumes for the exiting, entering and through movements.
2. Between Interchanges. Where interchanges are closely spaced and an auxiliary lane is warranted at an entrance or exit, the designer should consider connecting the lane to the exit of the downstream interchange or entrance of the upstream interchange.

Design details for exits and entrances are provided in Section 48-4.0, and design details for lane drops are provided in Section 48-6.02.

48-3.08 Lane Reductions

A reduction in the basic number of lanes may be made beyond a principal interchange involving a major fork or at a point downstream from an interchange with another freeway. This reduction may be made provided the exit volume is sufficiently large enough to change the basic number of lanes beyond this point on the freeway route as a whole. Another situation where the basic number of lanes may be reduced is where a series of exits, as in outlying areas of a city, causes the traffic load on the freeway to drop sufficiently to justify the lesser number of lanes. Dropping a basic lane or an auxiliary lane may be accomplished at a two-lane exit ramp or between interchanges.

If a lane reduction of a basic lane or an auxiliary lane is made within an interchange, it should be made in conjunction with a two-lane exit, or in a single-lane exit with an adequate recovery lane. If a basic lane or auxiliary lane is to be dropped between interchanges, it should be accomplished at a distance of 2000 to 3000-ft from the previous interchange to allow for adequate signing.

Preferably, the lane reduction should be made on the driver's right side following an exit ramp, since there is likely to be less traffic in that lane. The end of the lane drop should be tapered into the highway in a manner similar to that at a ramp entrance. Preferably, the rate of taper should be longer than that for a ramp. The desirable taper rate should be 70:1, with a minimum rate of 50:1.

48-3.09 Safety Considerations

Safety is an important consideration in the selection and design of an interchange. After many years of operating experience and safety evaluations, certain practices are considered less desirable at interchanges nationwide. The following summarizes several major safety considerations.

1. **Exit Points.** Many interchanges have been built with exit points which could not clearly be seen by approaching drivers. Decision sight distance should be provided where practical at freeway exits, and the pavement surface should desirably be used for the height of object (0.0 in.). A 6-in. height of object is acceptable. See Section 48-4.01 for the application of decision sight distance to freeway exits. Proper advance signing of exits is also essential.
2. **Exit Speed Changes.** Freeway exits should provide sufficient distance for a safe deceleration from the freeway design speed to the design speed of the first governing geometric feature on the ramp, typically a horizontal curve.

3. Merges. Rear-end collisions on entrance merges onto a freeway may result from a driver attempting the complicated maneuver of simultaneously searching for a gap in the mainline traffic stream and watching for vehicles in front. An acceleration distance of sufficient length should be provided to allow a merging vehicle to attain speed and find a sufficient gap to merge into.
4. Driver Expectancy. Interchanges can be significant sources of driver confusion; therefore, they should be designed to conform to the principles of driver expectation. Left-hand merges are less desirable. It is difficult for a driver entering from a ramp to safely merge with the high-speed left lane on the mainline. Therefore, left exits and entrances should not be used, because they are not consistent with the concept of driver expectancy when they are mixed with right-hand entrances and exits. In addition, exits should not be placed in line with the freeway tangent section at the point of mainline curvature to the left.
5. Fixed Objects. Because of traffic operations at interchanges, a number of fixed objects may be located within interchanges, such as signs at exit gores or bridge piers and rails. These should be removed, where practical, made breakaway or shielded with barriers or crash cushions. Horizontal stopping sight distance should be considered. With the minimum radius for a given design speed, the normal lateral clearance at piers and abutments of underpasses does not usually provide the minimum stopping sight distance. Thus, above-minimum radii should be used for curvature on highways through interchanges. See Chapter Forty-nine.
6. Wrong-Way Entrances. In almost all cases, wrong-way maneuvers originate at interchanges. Some simply cannot be avoided, but many result from driver confusion due to poor visibility, confusing ramp arrangement or inadequate signing. The interchange design must attempt to minimize wrong-way possibilities.
7. Weaving. Areas of vehicular weaving may create a high demand on driver skills and attentiveness. Where practical, interchanges should be designed without weaving areas or, as an alternative, with weaving areas removed from the highway mainline (e.g., with collector-distributor roads).
8. Crossroad. The crossroad at a rural freeway interchange should be a divided roadway through the interchange area.

48-3.10 Capacity and Level of Service

The capacity of an interchange will depend upon the operation of its individual elements as follows:

1. basic freeway section where interchanges are not present,
2. freeway-ramp junctions,
3. weaving areas,
4. ramp proper, and
5. ramp/crossing road intersection.

The basic capacity reference is the *Highway Capacity Manual* (HCM). The HCM provides the analytical tools to analyze the level of service for each element listed above.

The interchange should operate at an acceptable level of service. The values presented in Tables 53-1 and 54-2A for freeways will also apply to interchanges. The level of service of each interchange element should be as good as the level of service provided on the basic freeway section. Interchange elements should not operate at more than one level of service below that of the basic freeway section. In addition, the operation of the ramp/crossing road intersection in urban areas should not impair the operation of the mainline. This will likely involve a consideration of the operational characteristics on the minor road for some distance in either direction from the interchange. For State projects, the Environment, Planning and Engineering Division's Environmental Services Section is responsible for conducting the preliminary capacity analyses at interchanges.

48-3.11 Testing for Ease of Operation

The designer should review the proposed design from the driver's perspective. This involves tracing all possible movements that an unfamiliar motorist would drive through the interchange. The designer should review the plans for areas of possible confusion, proper signing and ease of operation and to determine if sufficient weaving distances and sight distances are available. The designer should have available the peak-hour volumes, number of traffic lanes, etc., to determine the type of traffic the driver will encounter.

48-4.0 FREEWAY/RAMP JUNCTIONS

48-4.01 Exit Ramps

48-4.01(01) Types of Exit Ramps

There are two basic types of exit freeway/ramp junctions — the parallel design and the taper design.

Figure 48-4A illustrates these two exit freeway/ramp junction designs. For all new and reconstructed ramps, it is INDOT policy to only use the parallel design (Illustration A). Existing taper exit ramp designs (Illustration B) may be retained if deemed acceptable and there is not an adverse history of accidents at the ramp junction. However, the designer may want to consider replacing an existing taper design with a parallel design where:

1. a ramp exit is just beyond a structure and there is insufficient sight distance available to the ramp gore;
2. a taper design cannot provide the necessary deceleration distance prior to a sharp curve on the ramp;
3. the exit ramp departs from a horizontal curve on the mainline. The parallel design is less confusing to through traffic and will normally result in smoother operation;
4. the need is satisfied for a continuous auxiliary lane (see Section 48-3.07); and
5. the capacity of the at-grade ramp terminal is insufficient and ramp traffic may back up onto the freeway.

The INDOT *Standard Drawings* provide the detailed design information for the Department's typical parallel exit freeway/ramp junction. For design information on taper ramp junctions, the designer is referred to AASHTO *A Policy on Geometric Design of Highways and Streets*.

48-4.01(02) Taper Rates

For a parallel-lane exit design, the taper rate applies to the beginning taper of the parallel lane. This distance is typically 100-ft as illustrated in Figure 48-4A.

48-4.01(03) Deceleration

Sufficient deceleration distance is needed to safely and comfortably allow an exiting vehicle to leave the freeway mainline. All deceleration should occur within the full width of the parallel exit lane. The 1000-ft length of deceleration as shown in Figure 48-4A and the *INDOT Standard Drawings* will accommodate all design speeds and grades. It should always be used unless restricted conditions are present such as topographical features, adverse impacts, existing geometry, etc., which will not permit the use of the typical deceleration configuration.

48-4.01(04) Sight Distance

Decision sight distance should be provided for drivers approaching a freeway exit. This sight distance is particularly important for exit loops immediately beyond a structure. Vertical curvature or bridge piers can obstruct the exit points if not carefully designed. When measuring for adequate sight distance, the desirable height of object will be 0.0 in. (the roadway surface); however, it is acceptable to use 6-in. Chapter Forty-two discusses decision sight distance in more detail.

48-4.01(05) Superelevation

Superelevation for horizontal curves in the vicinity of the mainline/ramp junction must be developed to properly transition the driver from the mainline to the curvature at the exit. The principles of superelevation for open highways, as discussed in Chapter Forty-three, should be applied to the mainline/ramp junction. If drainage impacts to adjacent property or frequency of slow-moving vehicles are important considerations, low speed urban criteria may be used if the design speed on the ramp is 45 mph or less. The following will apply to superelevation development at exit ramps:

1. e_{\max} . On the exit ramp portion of the mainline/ramp junction, the typical e_{\max} is 8%.
2. Superelevation Rate. As discussed in Section 43-3.0, Method 5 is used for open highways to distribute superelevation and side friction. Therefore, Figure 43-3A(1) will be used to determine the proper superelevation rate for horizontal curves at exit ramps. The designer will use the ramp design speed and the curve radius to read into the tables to determine “e”, subject to R_{\min} for the ramp design speed. The superelevation rate and radii used should reflect a decreasing sequence of design speeds for the exit terminal, ramp proper, and at-grade terminal for diamond ramps.
3. Transition Length. The designer should use the superelevation transition lengths for 2-lane roadways as presented in Figure 43-3A(1) to transition the exit ramp cross slope to the superelevation rate at the PC.
4. Distribution. The superelevation transition length should be distributed such that 60 to 80% of the length is in advance of the PC and the remainder beyond the PC. However, at freeway/ramp junctions, field conditions may make this distribution impractical, and a different distribution may be necessary. However, it should not be less than 50/50.

5. Axis of Rotation. The axis of rotation is typically about the centerline of the ramp travelway.

48-4.01(06) Cross Slope Rollover

The cross slope rollover is the algebraic difference between the transverse slope of the through lane and the transverse slope of the exit lane and/or gore. The following will apply:

1. Up to Physical Nose. The cross slope rollover should not exceed the ranges as follows:

Design Speed, mph	Rollover, %
>60	4 - 5
40, 50	5 - 6
≤30	5 - 8

2. From Physical Nose to Gore Nose. The cross slope rollover should not exceed 8%.
3. Drainage Inlets. Where required, these are normally placed between the physical gore and gore nose. The presence of drainage inlets may require two breaks in the gore cross slope. These breaks should meet the criteria in Item #'s 1 or 2 above, depending on the inlet location.

See Section 48-4.01(08) for nose definitions.

48-4.01(07) Shoulders

The right shoulder of the mainline will be transitioned to the narrower shoulder of the ramp. As illustrated in Figure 48-4A and the INDOT *Standard Drawings* the shoulder width along the mainline will be maintained until 100-ft before the gore nose or ramp PC. The shoulder width will then be transitioned to the ramp right shoulder width (typically 8-ft). In restricted areas, it is acceptable to provide a 6-ft minimum right shoulder along the entire parallel exit ramp area.

48-4.01(08) Gore Area

The term *gore* indicates an area downstream from the intersection point of the mainline and exit shoulders. The gore area is normally considered to be both the paved triangular area between the through lane and the exit ramp, plus the graded area which may extend a hundred meters downstream beyond the gore nose. The following definitions will apply (see Figure 48-4B).

1. Painted Nose. This is the point (without width) where the pavement striping on the left side of the ramp converges with the stripe on the right side of the mainline travelway.
2. Dimension Nose. This is a point where the shoulder is considered to begin within the gore area. For exit ramps, the dimension nose is 4-ft wide.
3. Physical Nose. This is the point where the ramp and mainline shoulders converge. As illustrated in Figure 48-4B, the physical nose has a dimensional width of 14-ft.
4. Gore Nose. This is the point where the paved shoulder ends and the sodded area begins as the ramp and mainline diverge from one another. As illustrated in Figure 48-4B, the gore nose has a dimensioned width of 6-ft and does not include the shoulders.

The following should be considered when designing the gore.

1. Obstacles. If practical, the area beyond the gore nose should desirably be free of all obstacles (except the ramp exit sign) for at least 100-ft beyond the gore nose. Any obstacles within 300-ft of the gore nose are to be made breakaway or shielded by a barrier. See Section 49-3.0.
2. Side Slopes. The graded area beyond the gore nose should be as flat as practical. If the elevation between the exit ramp or loop and the mainline increases rapidly, this may not be practical. These areas will likely be non-traversable, and the gore design must shield the motorist from these areas. At some sites, the vertical divergence of the ramp and mainline will warrant protection for both roadways beyond the gore (see Section 49-3.0).
3. Cross Slopes. The paved triangular gore area between the through lane and exit ramp should be safely traversable. The cross slope is the same as that of the mainline (typically 2%) from the painted nose up to the dimension nose. Beyond this point, the gore area is depressed with cross slopes of 2-4%. See Section 48-4.01(06) for criteria on breaks in cross slopes within the gore area.
4. Traffic Control Devices. Signing in advance of the exit and at the divergence should be according to the MUTCD and Chapter Seventy-five. See Chapter Seventy-six for the pavement marking details in the triangular area upstream from the gore nose.

48-4.02 Entrance Ramps

48-4.02(01) Types

There are two basic types of entrance freeway/ramp junctions — the parallel design and the taper design. Figure 48-4C illustrates these two entrance freeway/ramp junctions. It is INDOT policy to only use the parallel design on new and reconstructed ramps (Illustration A). The parallel design offers several advantages when compared to the taper design. The following lists a few examples:

1. Where the level of service for the freeway/ramp merge approaches capacity, a parallel design can be easily lengthened to allow the driver more time and distance to merge into the through traffic.
2. Where the acceleration length needs to be lengthened for grades and or trucks, the parallel design provides longer distances more easily than a taper design.
3. Where there is insufficient sight distance available for the driver to merge into the mainline (e.g., where there are sharp curves on the mainline), the parallel entrance ramp allows a driver to use the side-view and rear-view mirrors to more effectively locate gaps in the mainline traffic.
4. Where there is a need for a continuous auxiliary lane, the parallel-lane entrance can be easily incorporated into the design of the continuous auxiliary lane.

The INDOT *Standard Drawings* provide the detailed design information for the Department's typical parallel entrance freeway/ramp junction. For design information on taper entrances, the designer is referred to AASHTO *A Policy on Geometric Design of Highways and Streets*.

48-4.02(02) Taper Rates

For parallel-lane entrance ramps, the taper at the merge point is 300-ft minimum as illustrated in Figure 48-4C.

48-4.02(03) Acceleration

Driver comfort, traffic operations and safety will be improved if sufficient distance is available for acceleration. The length for acceleration will primarily depend upon the design speed of the last controlling horizontal curve on the entrance ramp and the design speed of the mainline. When determining the acceleration length, the designer should consider the following:

1. Passenger Cars. Figure 48-4D provides the minimum lengths of acceleration for passenger cars. The acceleration distance is measured from the PT of the last controlling curve to the beginning of the taper (see Figure 48-4C). Where upgrades exceed 2% over the acceleration distance, the acceleration length should be adjusted according to the values presented in Figure 48-4E.

The Department's acceleration lengths provide sufficient distance for acceleration of passenger cars. Where the mainline and ramp will carry traffic volumes approaching the design capacity of the merging area, the available acceleration distance should desirably total 1200-ft, exclusive of the taper, to provide additional merging opportunities. This distance is measured from the PT of the ramp entrance curve.

2. Trucks. Where there are a significant number of trucks to govern the design of the ramp, the truck acceleration distances provided in Figure 48-4F should be considered. Typical areas where trucks might govern the ramp design will include weigh stations, truck stops and transport staging terminals. At other freeway/ramp entrances, the truck acceleration distances should be considered where there is substantial entering truck traffic and where:
 - a. there is LOS D or worse at the junction,
 - b. there is a significant accident history involving trucks which can be attributed to an inadequate acceleration length, and/or
 - c. there is an undesirable level of vehicular delay at the junction attributed to an inadequate acceleration length.

Where upgrades exceed 2%, the truck acceleration distances may be corrected for grades. Figures 44-2B and 44-2C provide performance criteria for trucks on accelerating grades. Before providing any additional acceleration lane length, the designer must consider the impacts of the added length (e.g., additional construction costs, wider structures, right-of-way impacts).

3. Horizontal Curves. The specific application of the acceleration criteria to horizontal curves is as follows:
 - a. The design speed of the last horizontal curve on the ramp proper will be determined by open-highway conditions. These are discussed in Section 43-2.0.
 - b. For relatively short entrance ramps, the acceleration distance may be determined by that distance needed to accelerate from zero (at the beginning of the ramp) to the mainline design speed. The designer should check to determine if this distance governs.

48-4.02(04) Sight Distance

Decision sight distance should desirably be provided for drivers on the mainline approaching an entrance terminal. They need sufficient distance to see the merging traffic so they can adjust their speed or change lanes to allow the merging traffic to enter the freeway. Likewise, drivers on the entrance ramp need to see a sufficient distance upstream from the entrance to locate gaps in the traffic stream for merging. Section 42-2.0 discusses decision sight distance in more detail.

48-4.02(05) Superelevation

The entrance ramp superelevation should be gradually transitioned to meet the normal cross slope of the mainline. The principles of superelevation for open highways, as discussed in Section 43-3.01, should be applied to the entrance design. Section 48-4.01 provides the superelevation criteria for exit freeway/ramp junctions which are also applicable to entrance freeway/ramp junctions. This includes e_{\max} , superelevation rate, transition lengths, the distribution of transition lengths between curve and tangent, and the axis of rotation.

48-4.02(06) Cross Slope Rollover

The cross slope rollover is the algebraic difference between the slope of the through lane and the slope of the entrance lane, where these two are adjacent to each other. The maximum algebraic difference is 4% - 5% beyond the physical nose. Between the gore nose and physical nose, the maximum cross slope rollover is 8%. See Section 48-4.02(08) for gore area definitions.

48-4.02(07) Shoulder Transitions

At entrance terminals, the right shoulder must be transitioned from the narrower ramp shoulder to the wider freeway shoulder. Figure 48-4C and the *INDOT Standard Drawings* illustrate this typical shoulder transition. In restricted areas, it is acceptable to maintain the 6-ft right shoulder width on the ramp throughout the parallel lane until the merge with the mainline.

48-4.02(08) Gore Area

Section 48-4.01(08) provides the definitions for various nose types which are within the gore area. The following presents the nose dimensions for entrance gores.

1. Painted Nose. The painted nose dimension is considered to be 0.0 ft (i.e., the point where the two paint lines meet).
2. Dimension Nose. The dimension nose width for entrance ramps is 2-ft wide.
3. Physical Nose. The physical nose has a dimensioned width of 14-ft.
4. Gore Nose. The gore nose has a dimensioned width of 6-ft.

48-4.03 Continuous Auxiliary Lanes

For closely spaced interchanges, it may be warranted to provide a continuous auxiliary lane between the entrance ramp of one interchange and the exit ramp of the downstream interchange. A continuous auxiliary lane should be considered as follows:

1. the distance between the end of the entrance taper (without the connecting auxiliary lane) and the beginning of the downstream exit taper is relatively short (e.g., 1500-ft or less), and/or
2. a capacity and operational analysis indicates the need.

48-4.04 Multi-Lane Terminals

Multi-lane terminals may be required when the capacity of the ramp is too great for single-lane operation. They may also be used to improve traffic operations (e.g., weaving) at the junction. The following lists several elements the designer needs to consider when a multi-lane terminal is required:

1. Lane Balance. Lane balance at the freeway/ramp junction should be maintained. See Section 48-3.02.

2. Loop Ramps. Where the capacity analysis indicates that a single-lane loop capacity is insufficient, consideration should be given to providing either a 2-loop ramp or a direct connection ramp. For 2-lane loop ramps, the designer should consider the following:
 - a. Two-lane loop ramps with short radii are not recommended because, drivers are adverse to driving side-by-side with other vehicles and, therefore, tend to drive the ramp as a single-lane loop.
 - b. Expected design capacities for single-lane loops range from 800 to 1200 vph and for 2-lane loops, 1000 to 2000 vph.
 - c. Enough distance needs to be provided to properly design the exit and entrance for the second lane on the loop. See Items 3 and 4 below.
3. Entrances. INDOT policy is that, for multi-lane entrance ramps, a parallel-lane design should be used. Figure 48-4G illustrates a schematic of a typical multi-lane entrance ramp.
4. Exits. For a 2-lane exit ramp, the additional lane should be added at least 1300-ft prior to the terminal. The total length from the beginning of the first taper to the gore nose will range from 2500-ft for turning volumes of 1500 vph or less upward to 3500-ft for turning volumes of 3000 vph. Figure 48-4H illustrates a schematic of a typical parallel-lane multi-lane exit ramp.

Where a ramp splits or forks beyond the painted nose of the exit ramp, two parallel deceleration lanes should be provided prior to the gore nose for the 2500-ft length mentioned above. The exit taper to the parallel deceleration lanes should be 200-ft in length. This parallel deceleration lane concept should also be considered where vehicle storage is anticipated in the ramp lanes and deceleration lanes in advance of the crossroad intersection.
5. Signing. The geometric layout of multi-lane exits must be coordinated with the Traffic Design Section because of the complicated signing which may be required in advance of the exit.

48-4.05 Major Fork/Branch Connections

Figures 48-4I and 48-4J illustrate typical design details for a major fork or branch connection. The following lists a few geometric issues that the designer should consider when designing major divisions:

1. Lane Balance. The principle of lane balance should be maintained. See Section 48-3.02.

2. Divergence Point. Where the alignments of both roadways are on horizontal curves at a major fork, the painted nose of the gore should be placed in direct alignment with the centerline of one of the interior lanes. This provides a driver in the center lane the option of going in either direction. See Schematics A, B and C in Figure 48-4I. Where one of the roadways is on a tangent at a major fork, the gore design should be the same as a freeway/ramp multi-lane exit. See Schematic D in Figure 48-4I.
3. Nose Width. At the painted nose of a major fork, the lane should be at least 24-ft wide but preferably not over 28-ft. The widening from 12-ft to 24-ft should occur within a distance of 1000-ft to 1800-ft. See Schematic A in Figure 48-4 I.

If a design hourly volume of greater than 1500 is anticipated on the exit ramp at a major fork on a systems interchange, the exit deceleration lanes, exclusive of the exit tapers, should begin approximately 5240-ft before the painted gore nose.

4. Branch Connection. When merging, a full lane width should be carried for at least 1000-ft beyond the painted nose. See Schematic B in Figure 48-4J.

48-5.0 RAMP DESIGN

48-5.01 Design Speed

Figure 48-5A provides the acceptable ranges of ramp design speed based on the design speed of the mainline. The highway with the greater design speed should control in selecting the design speed for the ramp. However, the ramp design speed may vary. The portion of the ramp closer to the lower-speed highway should be designed for a lower speed. In addition, the designer should consider the following:

1. Freeway/Ramp Junctions. The design speeds in Figure 48-5A apply to the ramp proper and not to the freeway/ramp junction. Freeway/ramp junctions are designed using the freeway mainline design speed.
2. At-Grade Terminals. If a ramp will be terminated at an at-grade intersection with a stop or signal control, the design speeds in the figure may not be applicable to the ramp portion near the intersection. For additional information on the design speed selection near at-grade intersections, see Chapter Forty-six.

3. Variable Speeds. The ramp design speed may vary based on the two design speeds of the intersecting roadways. Higher design speeds should be used on the portion of the ramp near the higher-speed facility while lower speeds may be selected near the lower-speed facility. When using variable design speeds, the maximum speed differential between controlling design elements (e.g., horizontal curves, reverse curves) should not be greater than 10 to 20 mph. The designer needs to ensure that sufficient deceleration distance is available between design elements with varying design speeds (e.g., two horizontal curves).
4. Ramps for Right Turns. Design speeds for right-turn ramps are typically in the mid- to high range. This includes, for example, a diagonal ramp of a diamond interchange.
5. Loop Ramps. Design speeds in the high range are generally not attainable for loop ramps. Minimum values usually control. For mainline design speeds greater than 50 mph, the loop design speed should not be less than 20 mph. However, design speeds greater than 30 mph will require significantly more right-of-way and may not be practical in urban areas. Normally, a loop should not be designed for a speed greater than 35 mph. Arterial loop ramp radii should desirably be greater than 150-ft.
6. Semidirect Connections. Design speeds between the mid- to high ranges should be used for semidirect connections. Design speeds less than 30 mph should not be used. Design speeds greater than 50 mph are generally not practical for short, single-lane ramps. For 2-lane ramps, values in the mid- to high ranges should be used.
7. Direct Connections. For direct connections, the design speed should be in the mid to high range. The design speed should desirably be at least 45 mph but, as a minimum, it should not be less than 35 mph.

48-5.02 Cross Section

The INDOT *Standard Drawings* present the typical cross sections for tangent and for superelevated ramps. The following will also apply to the ramp cross section:

1. Width. The minimum paved width of a 1-way, 1-lane ramp will be 28 ft. The 28-ft width includes a 4-ft left shoulder, an 8-ft right shoulder and a 16-ft travelway. Multi-lane ramp widths should be in multiples of 12 ft, with a 4-ft wide left shoulder and a 10-ft wide right shoulder. The guardrail offset from the edge of shoulder should be 2 ft. The bridge railing offset should be 1'-8". Full-depth paving equal to the ramp pavement thickness should be provided on the shoulders because of frequent use of shoulders for turning movements and passing stalled vehicles

2. Pavement Design. Loop ramps and other ramps with curve radii less than or equal to 300-ft should be designed with full-depth pavement for the entire 28-ft width. For ramps with curve radii greater than 300-ft, only the 16-ft traveled way will typically have a full-depth pavement structure. Outer connector ramps at a cloverleaf-type interchange or the ramps at a diamond-type interchange should have full-depth shoulders. For additional pavement design information, see Chapter Fifty-two and the ramp cross section figures in Section 45-8.0.
3. Cross Slope. The traveled way cross slopes are typically 2%. Shoulder cross slopes are typically 4% on the right and 2% on the left and slope away from the traveled way. For all superelevated ramps, the entire 28-ft ramp width should have the same cross slope.
4. Curbs. In general, curbs should not be used on ramps. However, bituminous mountable curbing may be used for drainage or to prevent erosion on steep embankment slopes. See Section 49-3.04 for additional curbing information.
5. Bridges and Underpasses. The full paved width of the ramp should be carried over a bridge or beneath an underpass. The clear width under an underpass should also include the clear zone.
6. Side Slopes/Ditches. Side slopes and ditches should meet the same criteria as for the mainline. Section 45-3.0 and Section 45-8.0 provide additional information on the design of these elements.
7. Clear Zones. The clear zone from the edge of the traveled way portion of the ramp will be determined from Figure 49-2A. The design ADT will be the directional ADT on the ramp.
8. Barriers. Whenever practical, an additional 2-ft should be added to the shoulder width when a roadside barrier is used. Where a barrier is present on a horizontal curve, the designer should determine the barrier impact on horizontal sight distance. See Section 43-4.04.
9. Right-of-Way. The right-of-way adjacent to the ramp should be limited access right-of-way.

48-5.03 Horizontal Alignment

48-5.03(01) Theoretical Basis

Establishing horizontal alignment criteria for any highway element requires a determination of the theoretical basis for the various alignment factors. These include the side-friction factor (f), the distribution method between side friction and superelevation, and the distribution of the superelevation transition length between the tangent and horizontal curve. For horizontal alignment on the ramp proper, the theoretical basis will be one of the following:

1. Open-Road Conditions. Chapter Forty-three discusses the theoretical basis for horizontal alignment assuming open-road conditions. In summary, this includes the following:
 - a. relatively low side-friction factors (i.e., a relatively small level of driver discomfort);
 - b. the use of AASHTO Method 5 to distribute side friction and superelevation;
 - c. relatively flat longitudinal gradients for superelevation transition lengths; and
 - d. typically distributing 50% to 70% of the superelevation transition length to the tangent and the remainder to the horizontal curve.

2. Turning Roadway Conditions. Section 46-3.02 discusses the theoretical basis for horizontal alignment assuming turning roadway conditions. In summary, this includes the following:
 - a. higher side-friction factors than open-road conditions to reflect a higher level of driver acceptance of discomfort;
 - b. a range of acceptable superelevation rates for combinations of curve radii and design speeds to reflect the need for flexibility to meet field conditions for turning roadway design; and
 - c. the allowance of some flexibility in superelevation transition lengths and in the distribution between the tangent and curve.

For interchange ramps, the selection of which theoretical basis to use will be based on the portion of the ramp under design.

1. freeway/ramp junction,
2. ramp proper (directional ramps),
3. ramp proper (loop ramps),
4. ramp terminus (intersection control), or
5. ramp terminus (merge control).

In addition, several general controls will dictate horizontal alignment on interchange ramps. The following sections discuss all horizontal alignment criteria for ramps.

48-5.03(02) General Controls

The following will apply to the horizontal alignment of all ramp elements.

1. Superelevation Rates (Rural). For non-loop ramps in rural areas, the superelevation rate will be based on an $e_{\max} = 8\%$ and open-road conditions. See Figure 48-5B for specific superelevation rates based on ramp design speed and curve radius.
2. Superelevation Rates (Urban). For ramps in urban areas, the superelevation rate will be based on an e_{\max} of 4%, 6% or 8%, depending on site conditions. The highest rate practical should be used, especially for descending ramps. Desirably, open-road conditions will be used; it is acceptable to assume turning roadway conditions. Figure 48-5C presents specific superelevation rates for $e_{\max} = 6\%$ and Figure 48-5D for $e_{\max} = 4\%$ using open-road conditions. For turning-roadway conditions, see Section 46-3.02.
3. Superelevation Transitions. Open-road conditions, as discussed in Section 43-3.0, will also apply for transitioning to and from the needed superelevation on ramps. This includes the relative longitudinal gradients presented in Figure 43-3E, which have been used to calculate the superelevation runoff lengths presented in Figures 48-5B, 48-5C and 48-5D. The methodology presented in Section 43-3.0 is used to calculate the superelevation runoff and tangent runout distances with the following modifications.
 - a. One-Lane Ramps. The width of rotation (W) is assumed to be one-half the travelway width ($0.5 \times 16 = 8$ -ft). With this assumption, the minimum lengths in Column A in Figures 48-5B, 48-5C and 48-5D apply to one-lane ramps.
 - b. Two-Lane Ramps. The width of rotation (W) is assumed to be one-half of the widest travelway, which is determined by the minimum radius ($R = 180$ -ft) for the lowest ramp design speed ($V = 25$ mph) ($0.5 \times 27 = 13.5$ -ft).
4. Minimum Length of Design Superelevation. The designer should not superelevate curves on ramps such that the design superelevation rate is maintained on the curve for a very short distance. As a general rule, the minimum distance for design superelevation should be about 100-ft.
5. Axis of Rotation. This will typically be about the centerline of the ramp travelway.

6. Shoulder Superelevation. The criteria presented in Section 43-3.0 for superelevating the high side and low side of shoulders on open roadways will apply to superelevated curves on ramps. The entire ramp width should have the same cross slope.
7. Reverse Curves. To meet restrictive right-of-way requirements, ramps may be designed with reverse curves. Desirably, these reverse curves should be designed with a normal tangent section between. For ramps, however, it is often necessary to provide a continuously rotating plane between the reverse curves. If a continuously rotating plane is used, the distance between the PT and the succeeding PC should desirably be 100-ft. It is acceptable for the PT and PC to be coincident. See Section 43-3.0 for more information on superelevation at reverse curves.
8. Sight Distance. Section 43-4.0 presents the criteria for sight distance around horizontal curves based on the curve radii and design speed. These criteria also apply to curves on ramps. There should be a clear view of the entire exit terminal, including the exit nose and a section of the ramp roadway beyond the gore.

48-5.03(03) Freeway/Ramp Junctions

Horizontal alignment at freeway/ramp junctions is based on open-road conditions. This is discussed in Section 48-4.0.

48-5.03(04) Ramp Proper (Directional Ramps)

Directional ramps refer to those ramps which are relatively direct in their alignment. These include ramps at diamond interchanges, the outer ramps at cloverleaf interchanges and ramps at directional and semi-directional interchanges.

The ramp proper, for the purpose of horizontal alignment, is considered to begin at the gore nose on exit ramps and to end approximately 150-ft before the dimension nose on entrance ramps. See the discussion in Section 48-5.03(01) to determine whether open-road conditions or turning roadway conditions apply to the horizontal alignment on directional ramps.

48-5.03(05) Ramp Proper (Loop Ramps)

Loop ramps are those ramps on the interior portions of cloverleaf and partial cloverleaf interchanges. The ramp proper is considered to begin at approximately the physical nose on exit ramps and to end at approximately the physical nose on entrance ramps. Because of the normally

restrictive conditions for loop ramps, the curve radii are typically less than 300-ft. Therefore, it is desirable to use open-road conditions for horizontal alignment; although, typically, it is more practical to use turning roadway conditions.

48-5.03(06) Ramp Terminus (Intersection Control)

Interchange ramps may end at at-grade intersections. These may be stop control or signal control. If horizontal curves on the ramps are relatively close to the intersection, a design speed for the curve should be selected which is appropriate for expected operations at the curve. For these curves, the radius will determine whether open-road or turning roadway conditions apply. For $R \geq 300$ -ft, use open-road conditions. For $R < 300$ -ft, open-road conditions are desirable; turning roadway conditions are acceptable.

48-5.03(07) Ramp Terminus (Merge Control)

Interchange ramps may terminate with a merge into the intersecting road. The horizontal alignment at the ramp merge (or junction) will typically be based on open-road conditions. Profiles of highway ramp terminals should desirably be designed with a platform on the ramp side of the approach nose or merging end. This platform should be at least 200-ft in length. It should have a profile that does not greatly differ from that of the adjacent traffic lane.

48-5.04 Vertical Alignment

48-5.04(01) Grades

Maximum grades for vertical alignment on ramps cannot be as definitively expressed as those for highway mainline. General values of limiting gradients are 3% to 5% but, for any one ramp, the selected gradient is dependent upon a number of factors. These include the following:

1. The flatter the gradient on the ramp, the longer it will be. At restricted sites (e.g., loops), it may be necessary to provide a steeper grade to shorten the length of ramp.
2. The steepest gradients should be designed for the center portion of the ramp. Freeway/ramp junctions and landing areas at at-grade intersections should be as flat as practical.

3. Short upgrades of as much as 5% do not unduly interfere with truck and bus operations. Consequently, for new construction it is desirable to limit the maximum gradient to 5%.
4. Downgrades on ramps should follow the same guidelines as upgrades. They may, however, safely exceed these values by 1%, with 6% considered to be a maximum. The 6% downgrade should only be used in extreme conditions and where restrictive geometric elements are clearly visible to the driver.
5. The ramp grade within the freeway/ramp junction up to the physical nose should be approximately the same grade as that provided on the mainline. However, adequate sight distance is more important than grade control.

Design Speed, mph	20-25	25-30	35	45-50
Desirable Maximum Grade, %	6 to 8	5 to 7	4 to 6	3 to 5

48-5.04(02) Vertical Curvature

Vertical curves on ramps should be designed the same as those on the mainline. At a minimum, they should be designed to meet the stopping sight distance criteria. The ramp profile often assumes the shape of the letter S with a sag vertical curve at the lower end and with a crest vertical curve at the upper end. In addition, the vertical curvature of the ramp should be compatible with that of the mainline up to the physical nose. Where a crest or sag vertical curve extends onto the freeway/ramp junction, the length of curve should be determined using a design speed intermediate between those on the ramp and the highway. See Chapter Forty-four for details on the design of vertical curves.

48-5.05 Roadside Safety

The criteria in Chapter Forty-nine (e.g., clear zones, barrier warrants) will apply to the roadside safety design of interchange ramps. One special situation is the requirement for a median barrier between adjacent on/off ramps (e.g., between the outside directional ramp and inside loop ramp for a cloverleaf interchange). This will be determined on a case-by-case basis. This situation typically occurs at full or partial cloverleaf interchanges.

48-6.0 OTHER INTERCHANGE DESIGN CONSIDERATIONS

48-6.01 General

The following lists several design issues the designer should consider.

1. Design Year. The design year for the minor road intersecting the freeway should be the same as used for the freeway. The termination of other roads and streets in the area may generate a significant increase of traffic on the crossing facility.
2. Over versus Under. The decision on whether the freeway should go over or under the cross road is normally dictated by topography. If the topography does not favor one over the other, the following factors can be used as a guide to determine which highway should cross over the other.
 - a. The designer should consider which alternative will be more cost effective to construct. Some elements are the amount of fill, grading, span lengths, angle of skew, gradients, sight distances, geometrics, constructability, traffic control and costs.
 - b. One benefit of the cross road going over the freeway is that this may improve the ramp gradients. As drivers exit the freeway, they will normally tend to slow down going up an exit ramp and speed up going down an entrance ramp.
 - c. The alternative which provides the highest design level for the major road should be selected. Typically, the crossing road has a lower design speed; therefore, the minor road typically can be designed with steeper gradients, lesser widths, reduced vertical clearance requirements, etc.
 - d. If any crossings and/or structures are planned for a future date, the mainline should go under these future crossings. Overpasses are easier to install and will be less disruptive to the major road when they are constructed in the future.
3. Underpass Width. The approach cross section, desirably including clear zones, should be carried through the underpass. Including the clear zone allows for possible expansion in the future with minimal disruption to the overhead structure. In addition, wider underpasses also provide greater sight distance for at-grade ramp terminals near the structure.
4. Grading. The designer should consider the grading around an interchange early in design. Properly graded interchanges allow the overpass structures to naturally blend into the terrain. In addition, the designer needs to ensure that the slopes are not too steep to support the bridge and roadways and that they can support plantings which prevent erosion and enhance the appearance of the area. Flatter slopes also allow easier maintenance.

48-6.02 Freeway Lane Drops

Freeway lane drops, where the basic number of lanes is decreased, must be carefully designed. They should normally occur on the freeway mainline away from any other turbulence such as interchange exits and entrances. However, it may be advantageous to drop a basic freeway lane at a 2-lane exit.

Figure 48-6A illustrates the recommended design of a lane drop beyond an interchange. The following criteria are important when designing a freeway lane drop.

1. **Location.** Desirably the lane drop should occur approximately 2000 ft – 3000 ft beyond the previous interchange. Under restricted conditions, the MUTCD signing distance is acceptable. This distance allows adequate signing and driver adjustments from the interchange, but yet is not so far downstream that drivers become accustomed to the number of lanes and are surprised by the lane drop. In addition, a lane should not be dropped on a horizontal curve or where other signing is required, such as for an upcoming exit.

In urban areas, interchanges may be closely spaced for considerable lengths of highway. In these cases, it may be necessary to drop a freeway lane at an exit. Where this is necessary, it is preferable to drop a freeway lane at a 2-lane exit rather than a single-lane exit. As discussed in Section 48-3.0, a lane should not be dropped at an exit unless there is a large decrease in traffic demand for a significant length of freeway (e.g., 10 mph).

2. **Transition.** Desirably, the transition taper length will be 70:1. The minimum taper rate that can be used is 50:1 (see Figure 48-6A).
3. **Sight Distance.** Decision sight distance (DSD) should be available to any point within the entire lane transition. See Section 42-2.0 for applicable DSD values. When determining the availability of DSD, the desirable height of object will be 0.0 in. (the roadway surface); it is acceptable to use 6-in. This criterion would favor, for example, placing a freeway lane drop within a sag vertical curve rather than just beyond a crest.
4. **Right-Side versus Left-Side Drop.** Right-side freeway lane drops are preferred; however, a left-side lane reduction may be more practical at specific locations (e.g., where it is planned to continue the left lane in the median in the future).
5. **Shoulders.** The full-width right shoulder will be maintained through a right-side lane drop. If a left-side lane drop will be used to reduce the number of lanes from three to two, the left shoulder will be reduced from 10-ft (or 12-ft) to 4-ft. The full 10-ft left shoulder should be maintained for a distance of approximately 300-ft beyond the merge point of the dropped lane. This provides an area to allow a driver, who may have missed the signing, an

opportunity to safely merge with the through traffic. A full-depth shoulder pavement needs to be provided for 300-ft beyond the merge point.

48-6.03 Collector-Distributor Roads

In general, interchanges that are designed with single exits are superior to those with two exits, especially if one of the exits is a loop ramp or the second exit is a loop ramp preceded by a loop entrance ramp. Whether used in conjunction with a full cloverleaf or with a partial cloverleaf interchange, the single-exit design may improve the operational efficiency of the entire interchange.

Collector-distributor (C-D) roads use the single exit approach to improve the interchange operational characteristics. C-D roads will:

1. remove weaving maneuvers from the mainline and transfer them to the slower speed C-D roads,
2. provide high-speed single exits and entrances from and onto the mainline,
3. satisfy driver expectancy by placing the exit in advance of the separation structure,
4. simplify signing and the driver decision-making process, and
5. provide uniformity of exit patterns.

C-D roads are most often warranted when traffic volumes are so high that the interchange without them cannot operate at an acceptable level of service, especially in weaving sections. They are particularly advantageous at full cloverleaf interchanges where the weaving between the ramp/mainline traffic can be very difficult. Figure 48-2E illustrates a schematic of a C-D within a full cloverleaf interchange.

C-D roads may be one or two lanes, depending upon the traffic volumes and weaving conditions. Lane balance should be maintained at the exit and entrance points of the C-D road. The design speed of a C-D road usually ranges from 45 to 50 mph; however, it should desirably be within 10 mph of the mainline design speed. The separation between the C-D road and mainline should be as wide as practical but not less than that required to provide the applicable shoulder widths and a longitudinal barrier between the two (e.g., 20 to 25 ft).

48-6.04 Frontage Roads

The designer must consider the impact of frontage roads, where present, on interchange design. At some urban interchanges, it may be impractical to separate the intersections of the ramp and frontage road with the crossing road. In these cases, the only alternative is to merge the ramp and frontage road before the intersection with the crossing road. This can apply to either the exit or entrance ramp.

Figure 48-6B provides the basic schematic for this design. This design may only be used in restricted urban areas. The critical design element is the distance A between the ramp/frontage road merge and the crossing road. This distance must be sufficient to allow traffic weaving, vehicular deceleration and stopping, and vehicular storage to avoid interference with the merge point. Figure 48-6B also presents general guidelines which may be used to estimate this distance during the preliminary design phase. A number of assumptions have been made including weaving volume, operating speeds and intersection queue distance. Therefore, a detailed analysis will be necessary to firmly establish the needed distance to properly accommodate vehicular operation. Additional information can be found in a Transportation Research Record 682 report entitled, "Distance Requirements for Frontage-Road Ramps to Cross Streets: Urban Freeway Design."

Distance "B" in Figure 48-6B is determined on a case-by-case basis. It should be determined based on the number of frontage road lanes and the intersection design. This distance is typically determined by the weave distance from the intersection to ramp entrance. For capacity analysis of the weave section, see the *Highway Capacity Manual*. Under some circumstances this distance may be 0.0 ft.

The following summarizes the available options for coordinating the design of the interchange ramps, frontage road and crossing road:

1. Slip Ramps. Slip ramps may be used to connect the freeway with 1-way frontage roads before (or after) the intersection with the crossing road. Newly constructed slip ramps to a 2-way frontage road are unacceptable because they may induce wrong-way entry onto the freeway and may cause accidents at the intersection of the ramp and frontage road.
2. Separate Intersections. Separate ramp/crossing road and frontage road/crossing road intersections may be accomplished by curving the frontage road away from the ramp and intersecting the frontage road with the crossing road outside the ramp limits of full access control. Figure 48-6D provides an illustration of this separation. This treatment allows the two intersections to operate independently, and it eliminates the operational and signing problems of providing the same point of exit and entrance for the frontage road and freeway ramp.

Section 45-7.0 discusses overall design criteria for frontage roads (e.g., functional class, outer separation).

48-6.05 Ramp/Crossing Road Intersection

At service interchanges, the ramp will typically end with an at-grade intersection at the cross road. In general, the intersection should be treated as described in Chapter Forty-six. This will involve a consideration of capacity and the physical geometric design elements such as sight distance, angle of intersection, acceleration lanes, channelization and turning lanes. However, several points require special attention in the design of the ramp/crossing road intersection:

1. Capacity. In urban areas where traffic volumes are often high, inadequate capacity of the ramp/crossing road intersection can adversely affect the operation of the ramp/freeway junction. In a worst case situation the safety and operation of the mainline itself may be impaired by a backup onto the freeway. Therefore, special attention should be given to providing sufficient capacity and storage for an at-grade intersection or a merge with the crossing road. This may require adding additional lanes at the intersection or on the ramp proper, or it could involve traffic signalization where the ramp traffic will be given priority. The analysis must also consider the operational impacts of the traffic characteristics in either direction on the intersecting road.
2. Sight Distance. Section 46-10.0 discusses the criteria for intersection sight distance. These criteria also apply to a ramp/crossing road intersection. Special attention must be given to the location of the bridge pier, abutment, sidewalk, bridge rail, roadside barrier, etc. These may present major sight distance obstacles. The bridge obstruction and the required intersection sight distance may result in the need to relocate the ramp/crossing road intersection.
3. Wrong-Way Movements. Wrong-way movements may originate at the ramp/crossing road intersection. The intersection must be properly signed and designed to minimize the potential for a wrong-way movement (e.g., channelization).
4. Turn Lanes. Additional turn lanes are often required at the end of ramp. Section 46-4.0 provides information on the design of turn lanes at intersections at-grade.
5. Distance Between Free-Flow Terminal and Structure. The terminal of a ramp should not be near the grade-separation structure. If it is not practical to place the exit terminal in advance of the structure, the existing terminal on the far side of the structure should be well-removed. When leaving, drivers should be permitted some distance after passing the structure in which to see the turnout and begin the turnoff maneuver. Decision sight distance is recommended where practical. The distance between the structure and the approach nose at

the ramp terminal should be sufficient for exiting drivers to leave the through lanes without undue hindrance to through traffic.

48-6.06 Access Control

Proper access control must be provided along the crossing road in the vicinity of the ramp/crossing road intersection or along a frontage road where present. This will ensure that the intersection has approximately the same degree of freedom and absence of conflict as the freeway itself. The access control criteria should be consistent with these goals.

Figures 48-6C, 48-6D and 48-6E illustrate the access control for several typical interchange designs. These figures provide INDOT policy for the location of the full-access control lines along the ramp, at ramp/crossing road intersections, across from the ramp terminal and along frontage roads.

As indicated in the figures, the full-access control lines extend a distance along the crossing road beyond the ramp or frontage road taper extremity on both sides of the road. The 100-ft to 200-ft in urban areas and 300-ft to 500-ft in rural areas should usually satisfy any congestion concerns. However, in areas where the potential for development exists which would create traffic problems, it may be appropriate to consider longer lengths of access control. In addition, many areas have changed over the years from rural to urban. As indicated, the Department has adopted different criteria for the access control at urban and rural interchanges. However, a change in area character alone is not a sufficient justification to alter the location of the full-access control line when an existing interchange will be rehabilitated or when INDOT receives requests for additional access points from outside interests.

The figures note that, on the crossing road, the full-access control line should extend the indicated distance beyond “the ramp terminal.” For an exit ramp, this is defined as the tangent point (PT) of a radius return on the crossing road or the end of a taper for an entrance onto the crossing road (e.g., for an acceleration lane); i.e., the ramp terminal ends where the typical section of the crossing road resumes. A similar definition applies to ramp terminals for entrance ramps.

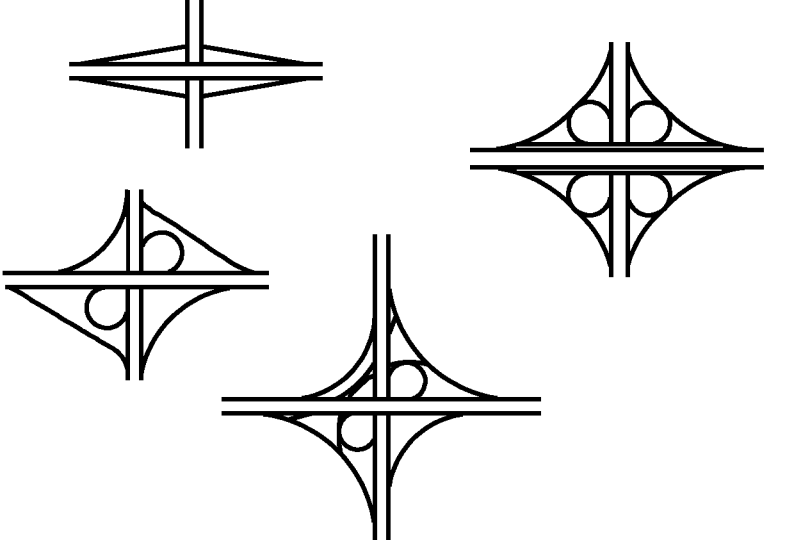
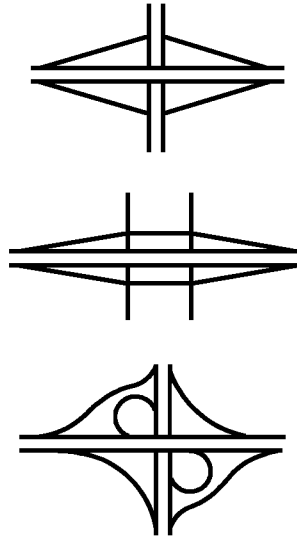
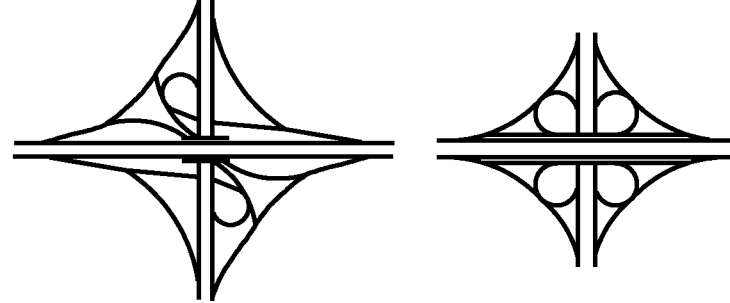
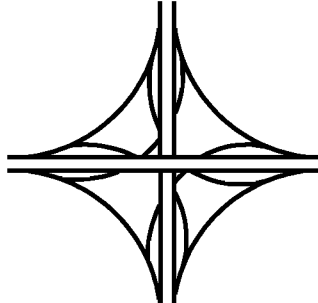
TYPE OF INTERSECTING FACILITY	RURAL	SUBURBAN URBAN
COLLECTORS AND ARTERIALS SERVICE INTERCHANGES		
FREEWAYS SYSTEMS INTERCHANGES		

FREEWAY INTERCHANGES
(Based on Functional Classification of Intersecting Facility)

Figure 48-2A

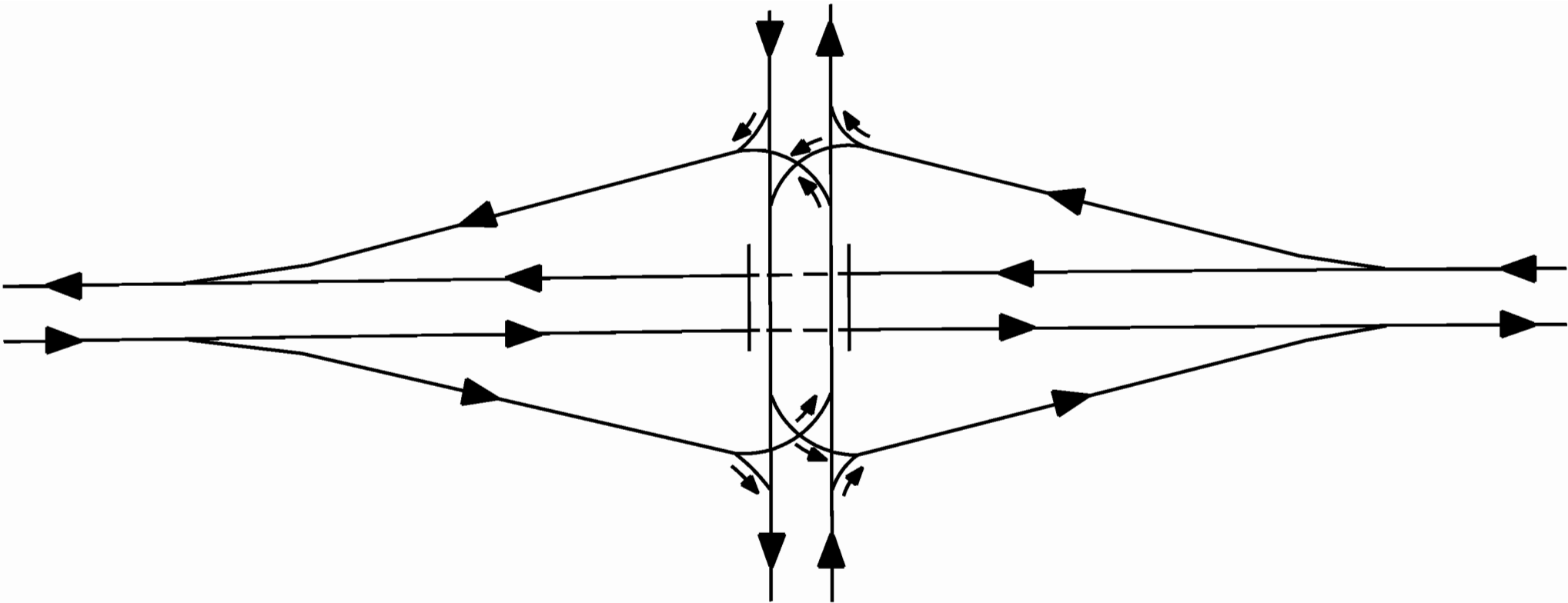

DIAMOND INTERCHANGE

Figure 48-2B

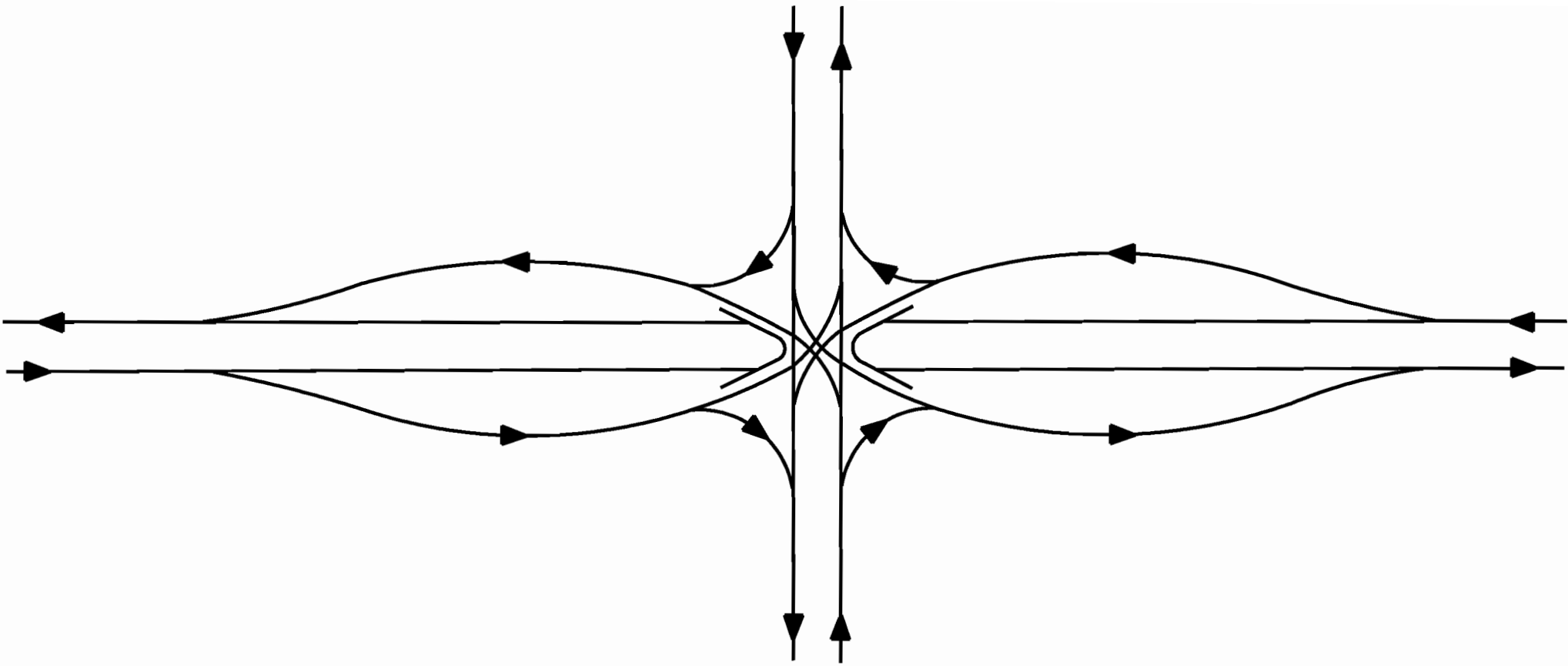

SINGLE POINT URBAN INTERCHANGE

Figure 48-2C

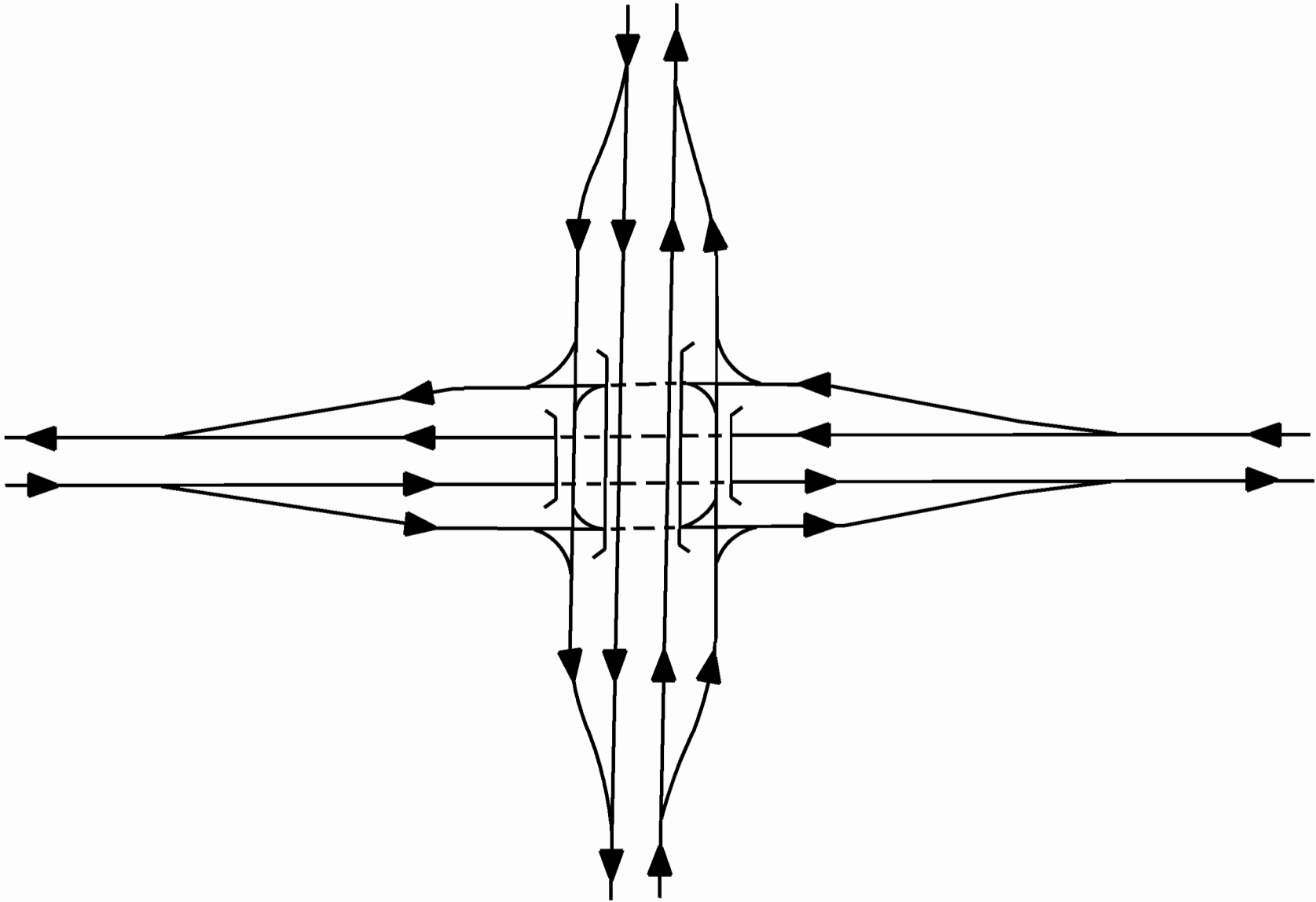

THREE-LEVEL DIAMOND INTERCHANGE

Figure 48-2D

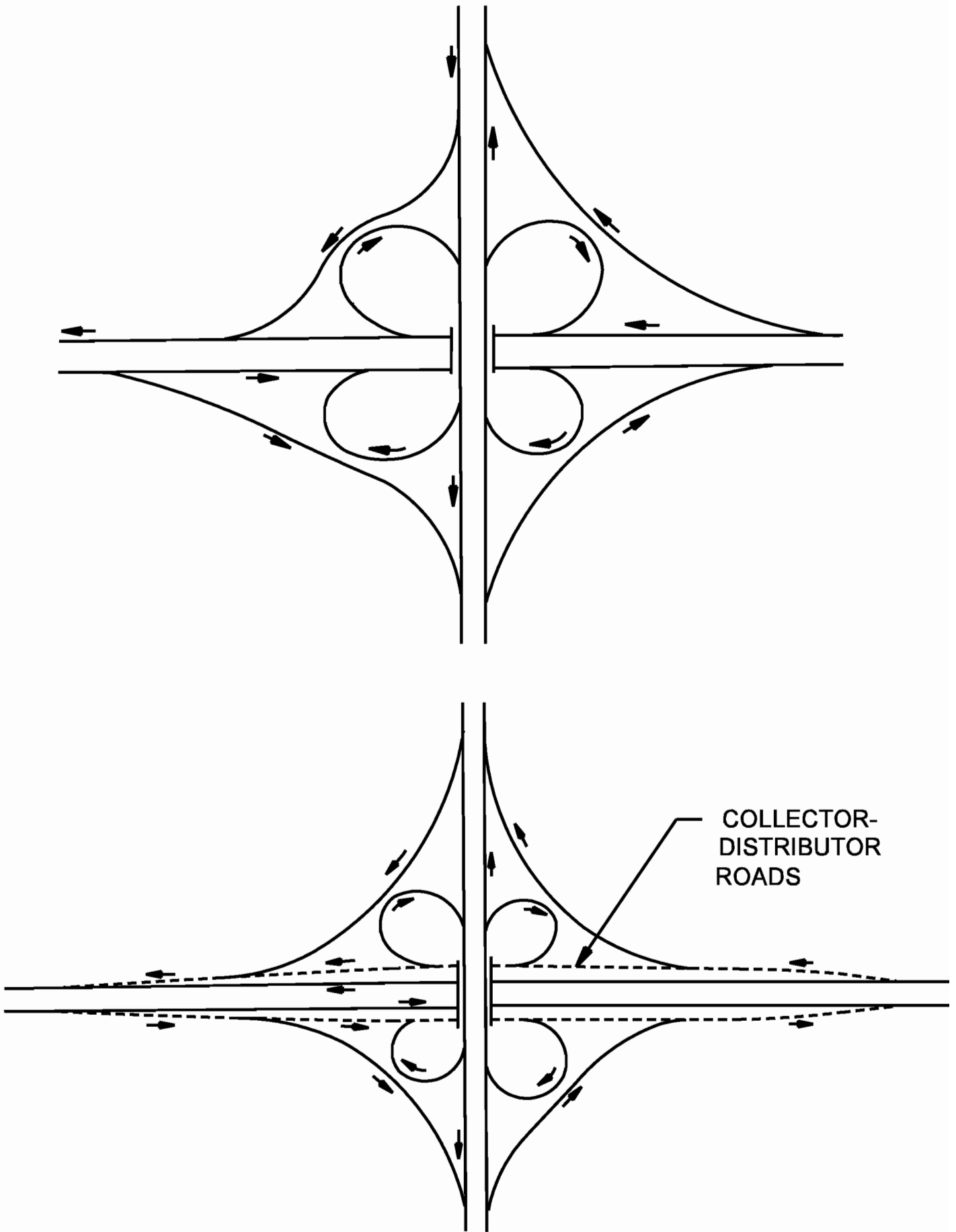

FULL CLOVERLEAFS

Figure 48-2E

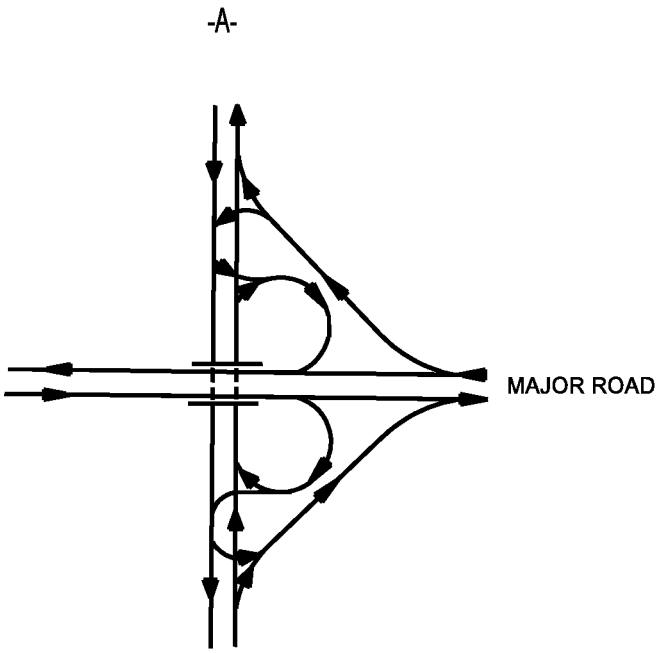

ON BOTH SIDES OF MAJOR ROAD
 LEFT TURNS: NONE ON MAJOR ROAD
 FOUR ON MINOR ROAD

TWO QUADRANTS ADJACENT

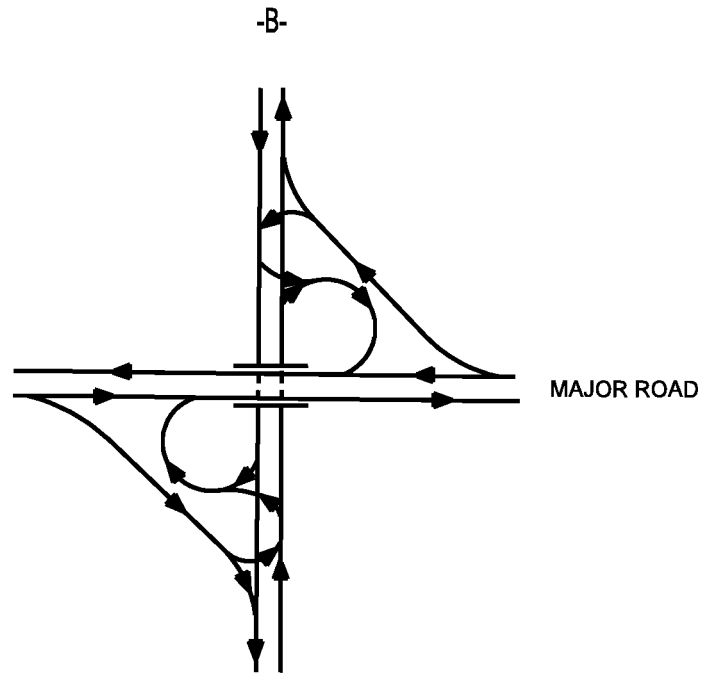

MAJOR ROAD EXITS ON NEAR SIDE
 LEFT TURNS: NONE ON MAJOR ROAD
 FOUR ON MINOR ROAD

TWO QUADRANTS
 DIAGONALLY OPPOSITE

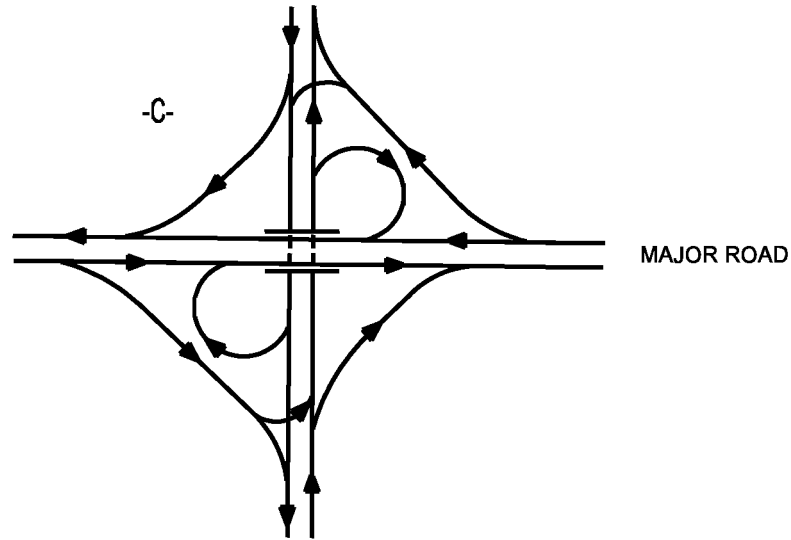

MAJOR ROAD EXITS ON NEAR SIDE
 LEFT TURNS: NONE ON MAJOR ROAD
 TWO ON MINOR ROAD

FOUR QUADRANTS

PARTIAL CLOVERLEAF ARRANGEMENTS

Figure 48-2F

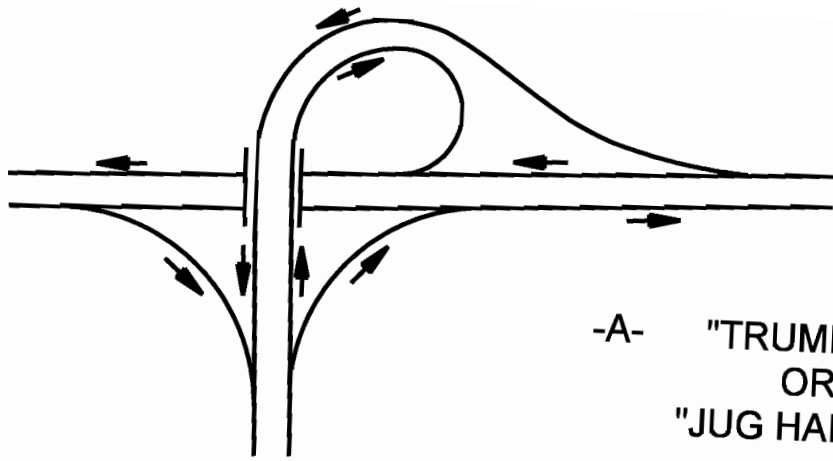

-A- "TRUMPET"
OR
"JUG HANDLE"

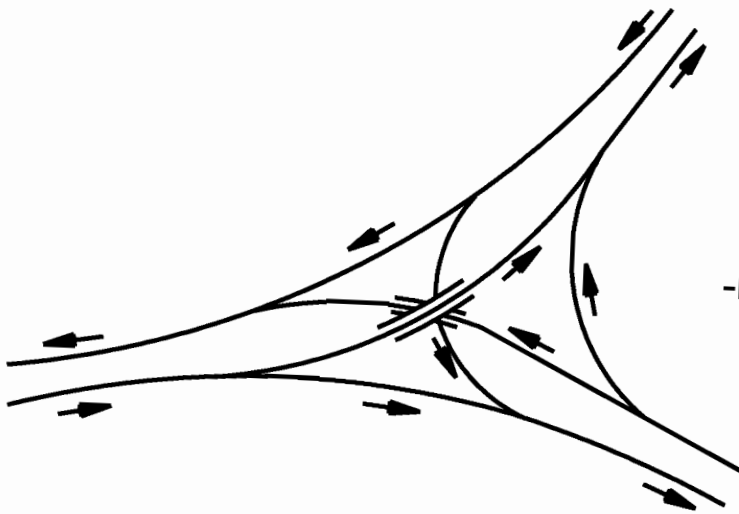

-B- "Y-TYPE"

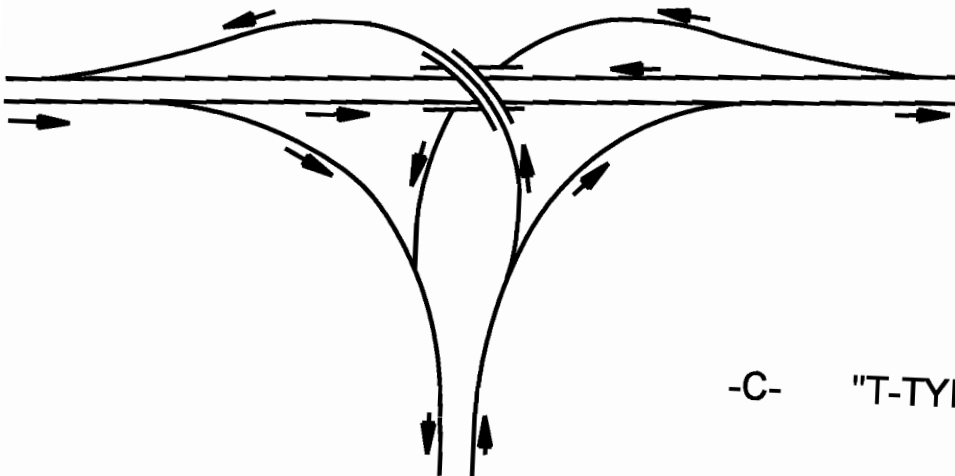

-C- "T-TYPE"

THREE-LEG INTERCHANGE

Figure 48-2G

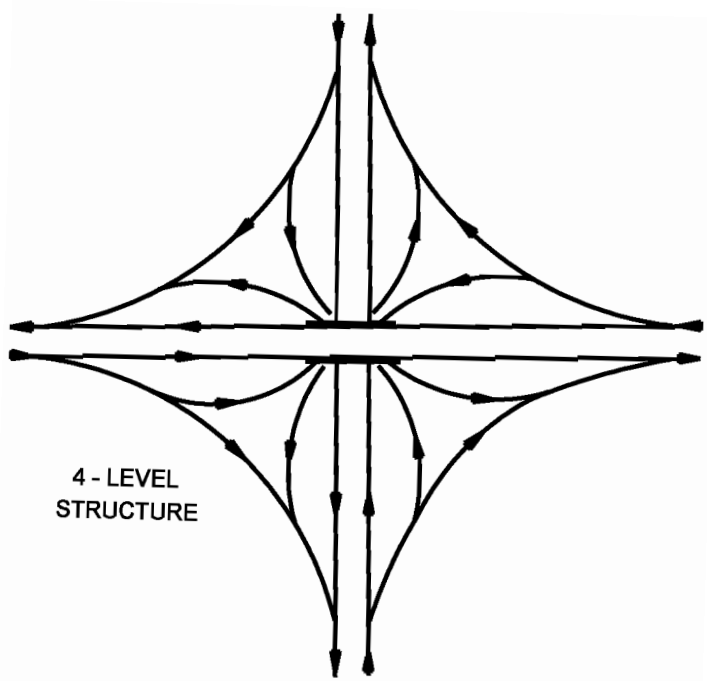

4 - LEVEL
STRUCTURE

FULLY DIRECTIONAL INTERCHANGE

Figure 28-2H

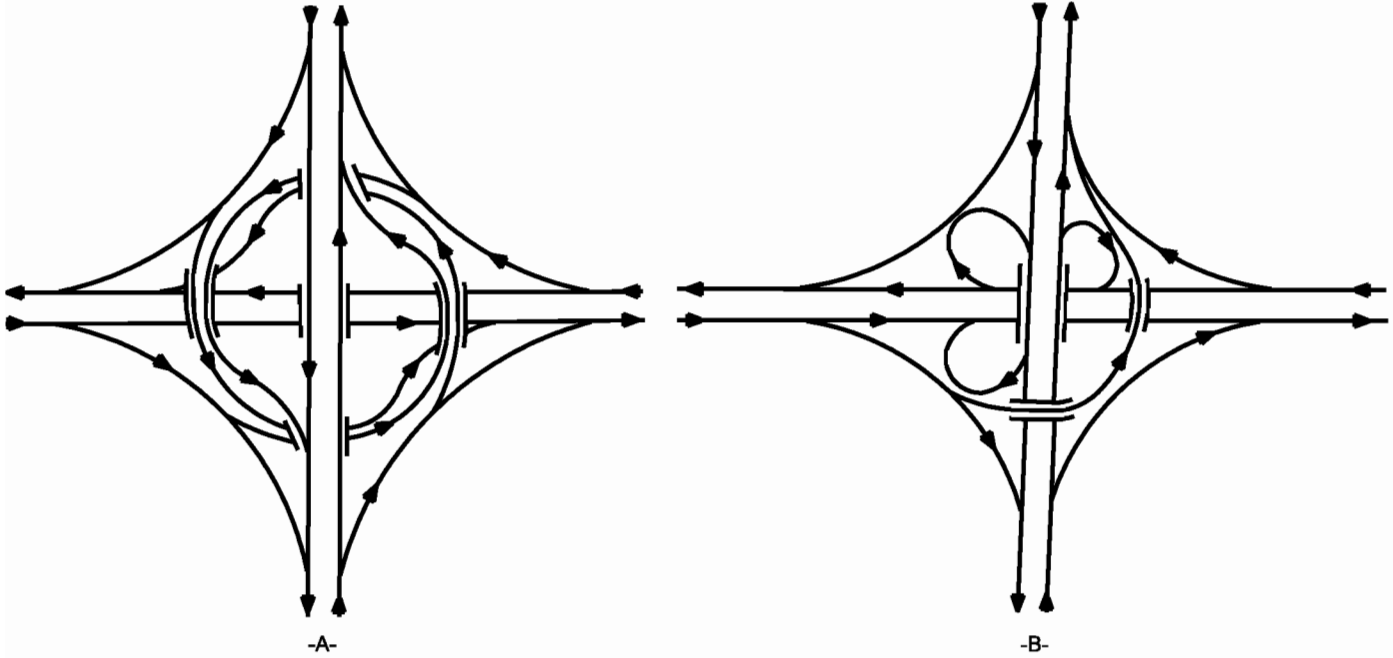

SEMI-DIRECTIONAL INTERCHANGES

Figure 28-21

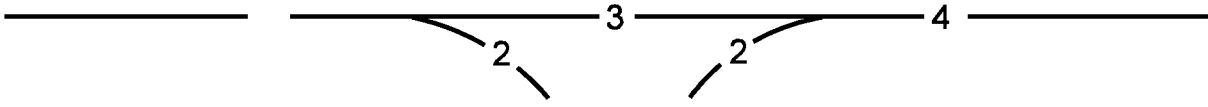

LANE BALANCE BUT NO COMPLIANCE WITH BASIC NUMBER OF LANES

-A-

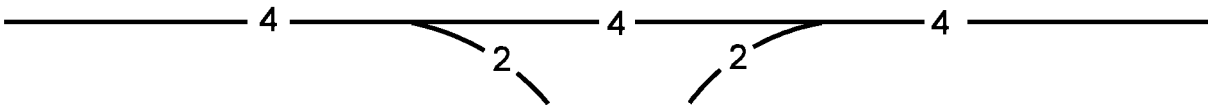

NO LANE BALANCE BUT COMPLIANCE WITH BASIC NUMBER OF LANES

-B-

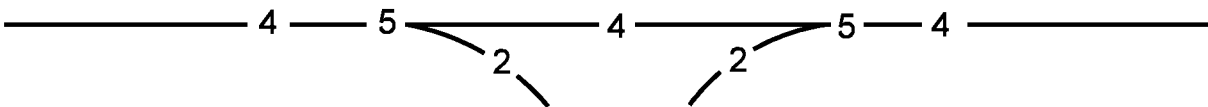

COMPLIANCE WITH BOTH LANE BALANCE AND BASIC NUMBER OF LANES

-C-

COORDINATION OF LANE BALANCE AND BASIC NUMBER OF LANES

Figure 48-3A

EN-EN OR EX-EX		EX-EN		DIRECTIONAL RAMPS		EN-EX (WEAVING)			
FULL FREEWAY CDR OR FDR		FULL FREEWAY	CDR OR FDR	SYSTEM INTER-CHANGE	SERVICE INTER-CHANGE	SYSTEM TO SERVICE INTERCHANGE		SERVICE TO SERVICE INTERCHANGE	
EN-EN	EX-EX					FULL FWY.	CDR OR FDR	FULL FWY.	CDR OR FDR
MINIMUM LENGTHS (L) MEASURED BETWEEN SUCCESSIVE RAMP TERMINALS (ft)									
1000	800	500	400	800	600	2000	1600	1600	1000

NOTE: FDR - FREEWAY DISTRIBUTOR ROAD EN - ENTRANCE
 CDR - COLLECTOR-DISTRIBUTOR ROAD EX - EXIT

- ① DISTANCE IS MEASURED FROM THE END OF TAPER TO THE GORE AND DESIRABLY SHOULD BE 700' OR MORE.
- ② FOR CLOVERLEAF LOOP RAMPS THIS DISTANCE SHOULD DESIRABLY BE 1000'.

The recommendations are based on operational experience and need for flexibility and adequate signing. They should be checked in accordance with the procedure outlined in the Highway Capacity Manual and Chapter Forty-one. The larger of the values is suggested for use. Also, a procedure for measuring the length of the weaving section is given in Chapter 4 of the Highway Capacity Manual.

RECOMMENDED MINIMUM RAMP TERMINAL SPACING

Figure 48-3B

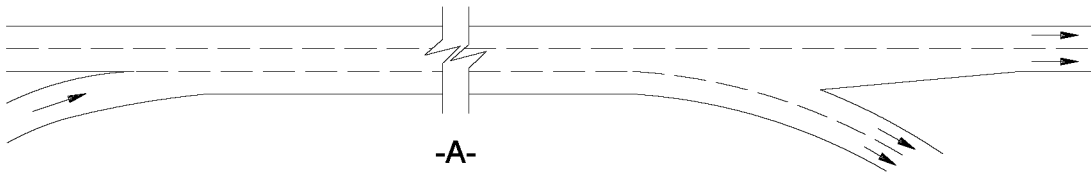

-A-
AUXILIARY LANE DROPPED ON EXIT RAMP

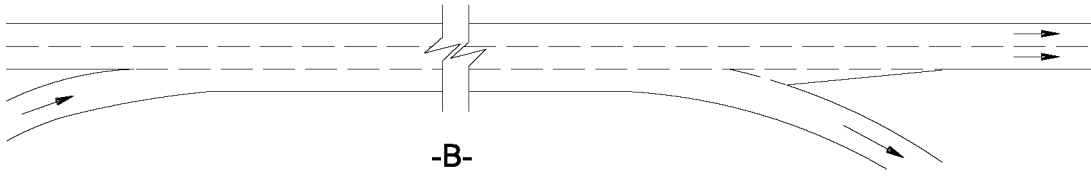

-B-
AUXILIARY LANE BETWEEN CLOVERLEAF LOOPS OR CLOSELY SPACED INTERCHANGES DROPPED ON SINGLE EXIT LANE

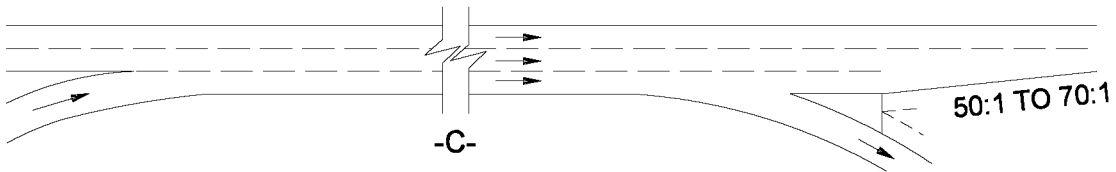

-C-
AUXILIARY LANE DROPPED AT PHYSICAL NOSE

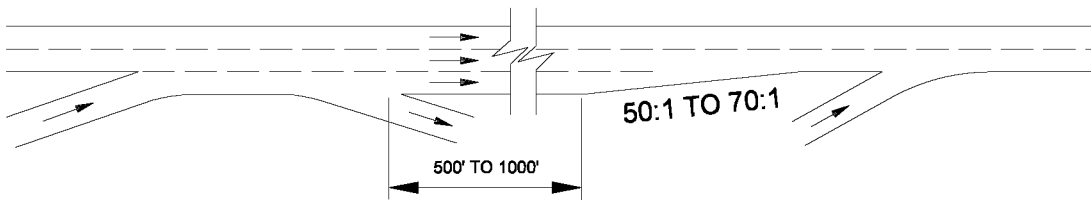

-D-
AUXILIARY LANE DROPPED WITHIN AN INTERCHANGE

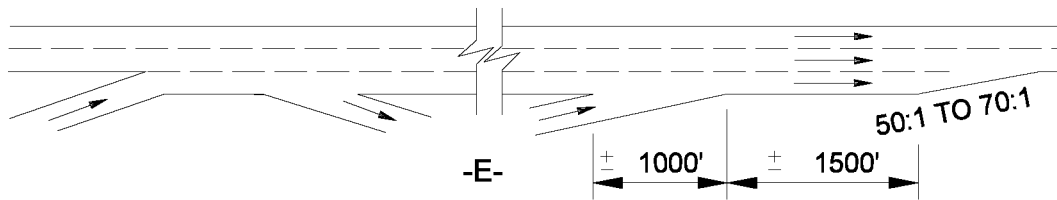

-E-
AUXILIARY LANE DROPPED BEYOND AN INTERCHANGE

ALTERNATE METHODS OF DROPPING AUXILIARY LANES

EFigure 48-3D

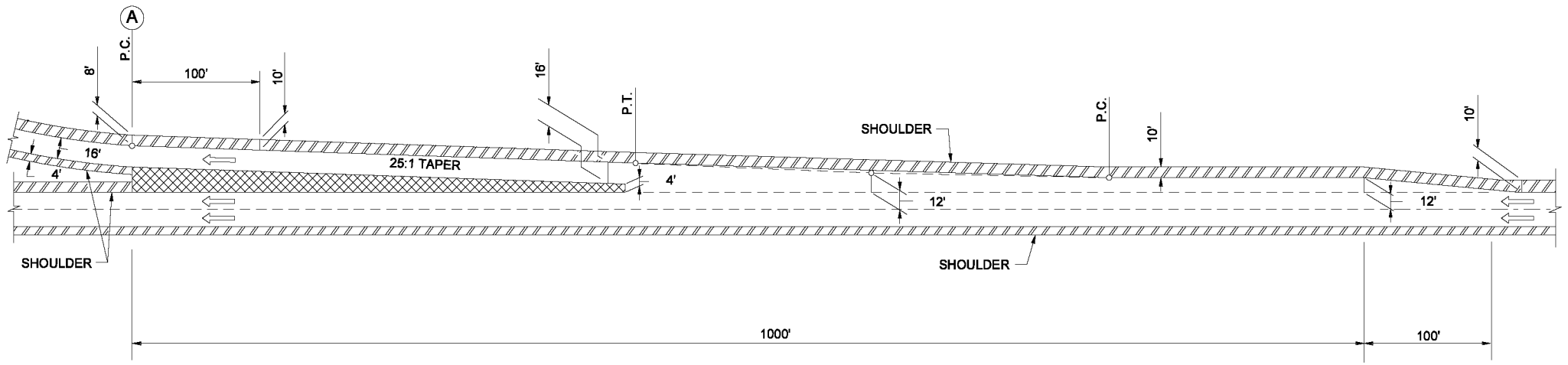

PARALLEL DESIGN (PREFERRED)

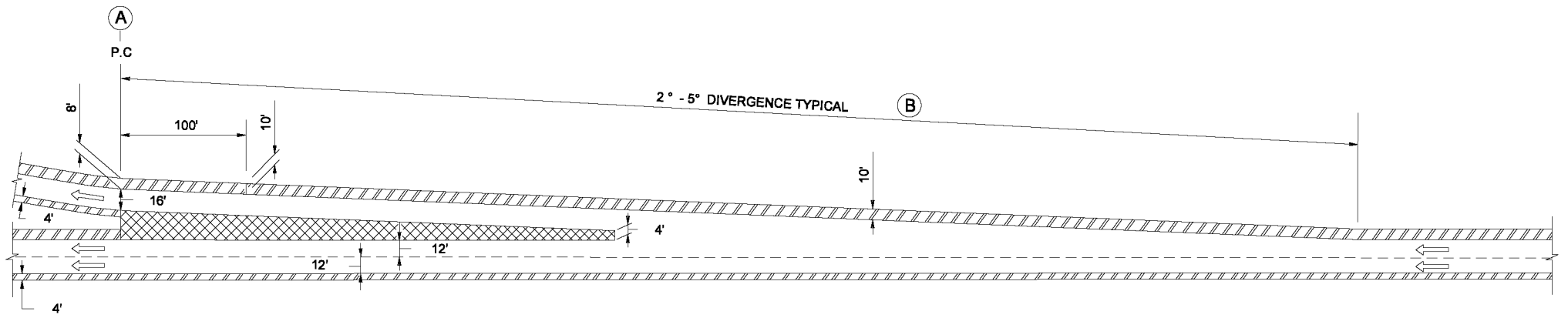

TAPERED DESIGN

- A Point controlling safe speed at ramp.
- B See AASHTO A Policy on Geometric Design of Highways and Streets for applicable deceleration distances.

**TYPICAL EXIT RAMP TYPES
(Single Lane)**

Figure 48-4A

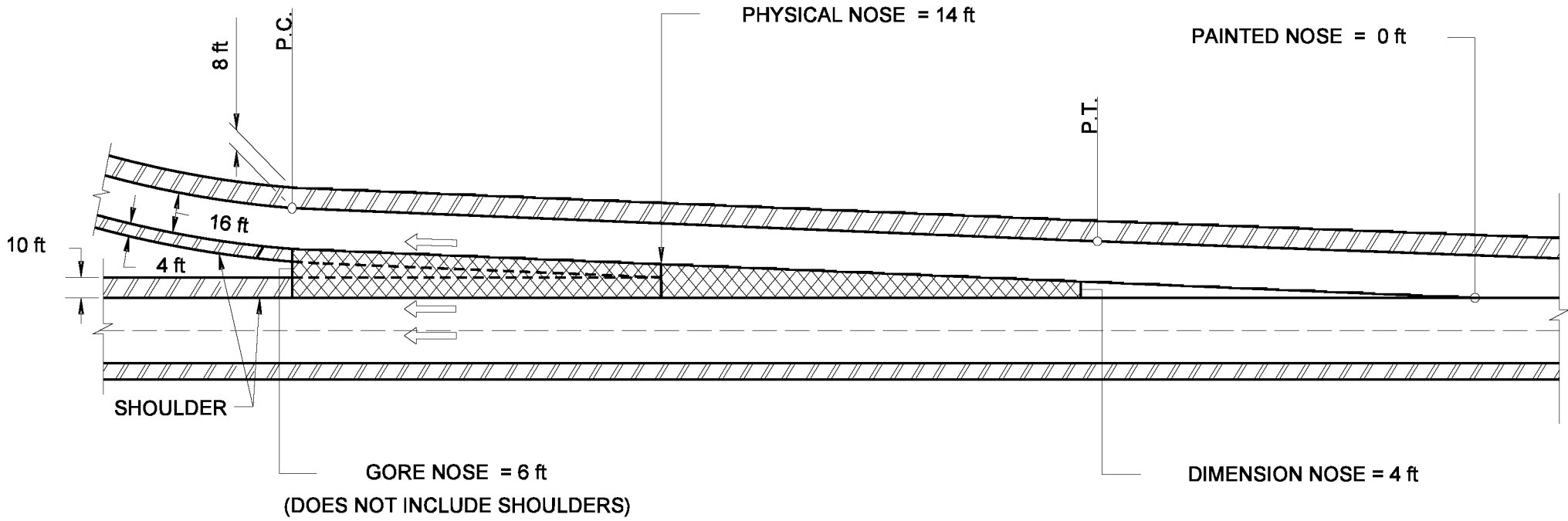

EXIT RAMP GORE AREA

Figure 48-4B

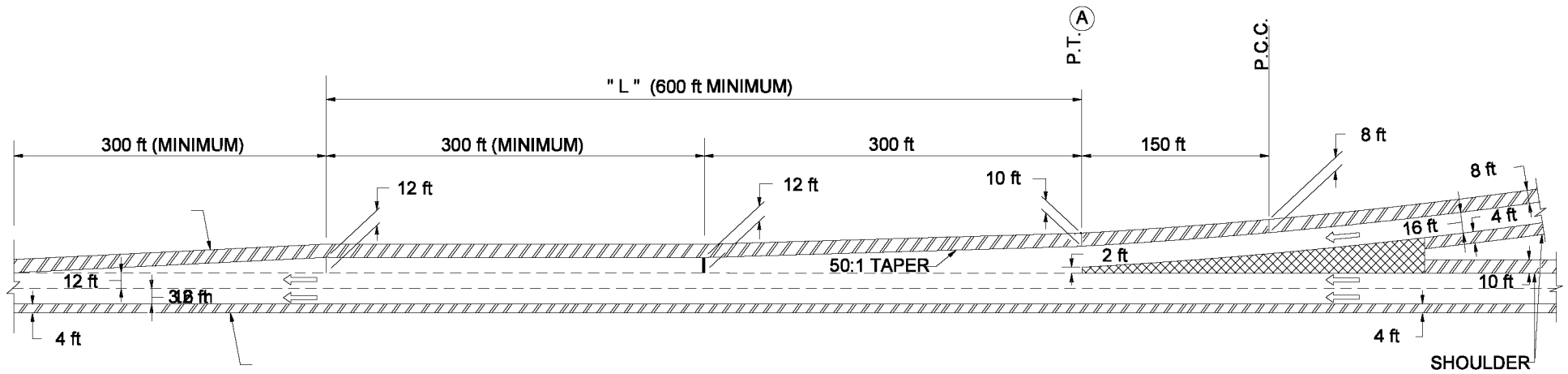

PARALLEL DESIGN (PREFERRED)

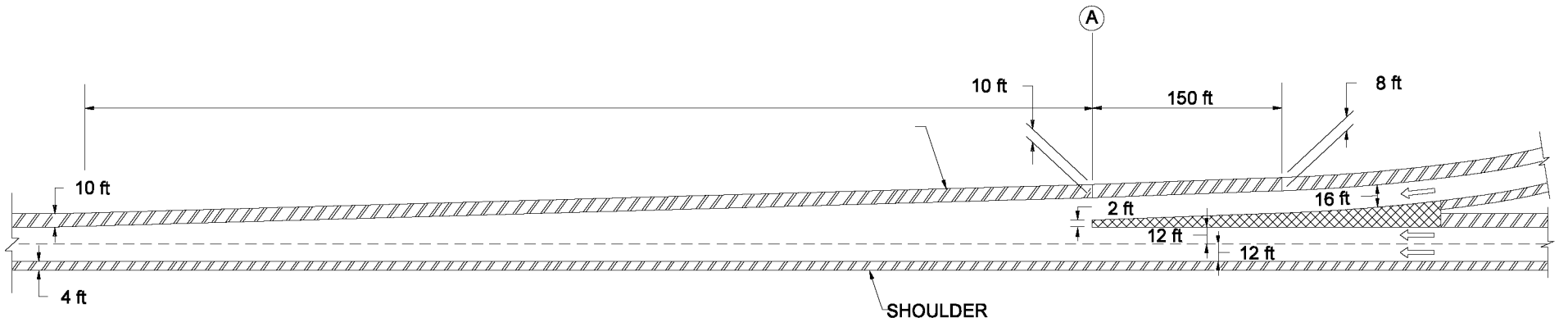

TAPERED DESIGN

Notes:

1. *L* is the required acceleration length as shown in the Figure 48-4D.
2. Point A controls safe speed on the ramp. *L* should not back on the curvature of the ramp unless the radius equals 1000 ft or more.
3. *L* is the distance downstream from where the nose width equals 0.6 m and is suggested for use in the design of the ramp entrance, except as noted in Note #2. above.

TYPICAL ENTRANCE RAMP TYPES
(Single Lane)

Figure 48-4C

Highway Design Speed (mph)	Speed Reached, V _a (mph)	Acceleration Length, L (ft)								
		for Entrance Curve Design Speed (mph)								
		Stop	15	20	25	30	35	40	45	50
		and Initial Speed, V _a (mph)								
		0	14	18	22	26	30	36	40	44
30	23	180	140	--	--	--	--	--	--	--
35	27	280	220	160	--	--	--	--	--	--
40	31	360	300	270	210	120	--	--	--	--
45	35	560	490	440	380	280	160	--	--	--
50	39	720	660	610	550	450	350	130	--	--
55	43	960	900	810	780	670	550	320	150	--
60	47	1200	1140	1100	1020	910	800	550	420	180
65	50	1410	1350	1310	1220	1120	1000	770	600	370
70	53	1620	1560	1520	1420	1350	1230	1000	820	580

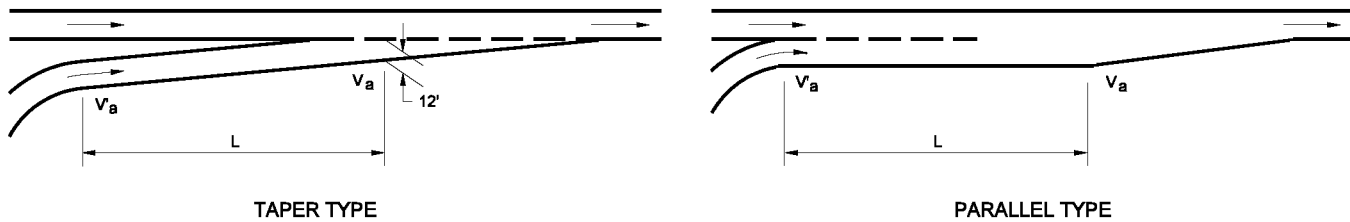

Note: Uniform 50:1 to 70:1 tapers are recommended where lengths of acceleration lane exceed 1300 ft.

Minimum Acceleration Lengths for Entrance Terminals
With Flat Grades of 2 Percent or Less

Figure 48-4D

Highway Design Speed (mph)	Ratio of Length on Grade to Length on Level for Ramp Curve Design Speed (mph)				
	20	30	40	50	All Speeds
40 45 50 55 60 65 70	3% ≤ Upgrade < 4%				3% ≤ Downgrade < 4%
	1.30	1.30	--	--	0.700
	1.30	1.35	--	--	0.675
	1.30	1.40	1.40	--	0.650
	1.35	1.45	1.45	--	0.625
	1.40	1.50	1.50	1.60	0.600
	1.45	1.55	1.60	1.70	0.600
	1.50	1.60	1.70	1.80	0.600
40 45 50 55 60 65 70	4% ≤ Upgrade ≤ 6%				4% ≤ Downgrade ≤ 6%
	1.50	1.50	--	--	0.600
	1.50	1.60	--	--	0.575
	1.50	1.70	1.90	--	0.550
	1.60	1.80	2.05	--	0.525
	1.70	1.90	2.20	2.50	0.500
	1.85	2.05	2.40	2.75	0.500
	2.00	2.20	2.60	3.00	0.500

- Notes: 1. No adjustment is needed for grades of flatter than 3%.
2. The grade in the table is the average grade measured over the distance for which the acceleration length applies.

Example

Given: Highway Design Speed - 70 mph
Entrance Ramp Curve Design Speed - 45 mph
Average Grade - 4.5% upgrade

Problem: Determine length of acceleration lane.

Solution: Figure 48-4D yields an acceleration length of 820 ft on the level. According to the table shown above, this should be increased by the average of the increases shown for 40 mph (2.60) and 50 mph (3.00), or 2.80.

Therefore: $L = (820 \text{ ft})(2.80)$
 $L = 2300 \text{ ft}$

An additional 2150 ft (2300 ft – 150 ft) should be added to the ramp prior to the entrance taper. See Figure 48-4C, Typical Entrance Types.

GRADE ADJUSTMENT FOR ACCELERATION (Passenger Car)

Figure 48-4E

Highway Design Speed (mph)	Speed Reached, V_a (mph)	L = Acceleration Length (ft)						
		For Design Speed of First Governing Geometric Control (mph)						
		Stop	20	25	30	40	45	50
		For Average Running Speed, V_a (mph)						
		0	20	24	28	36	40	44
30	20	165	--	--	--	--	--	--
40	24	250	115	--	--	--	--	--
45	29	495	395	265	--	--	--	--
50	34	870	770	660	430	--	--	--
55	38	1575	1495	1395	1200	575	--	--
60	43	2400	2315	2215	2020	1395	855	--
70	47	3315	3135	2955	2790	2380	1890	710

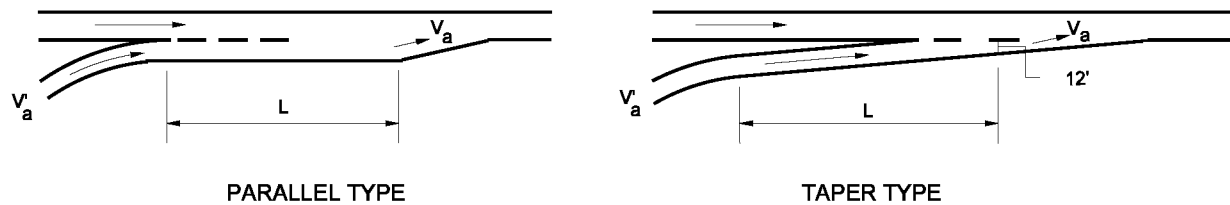

Note: The acceleration lengths are calculated from the distance needed for a 200 lb/hp truck to accelerate from the average running speed of the entrance curve to reach a speed (V_a) which is 10 mph below the average running speed on the mainline.

**LENGTHS FOR ACCELERATION
(200 lb/hp Truck)**

Figure 48-4F

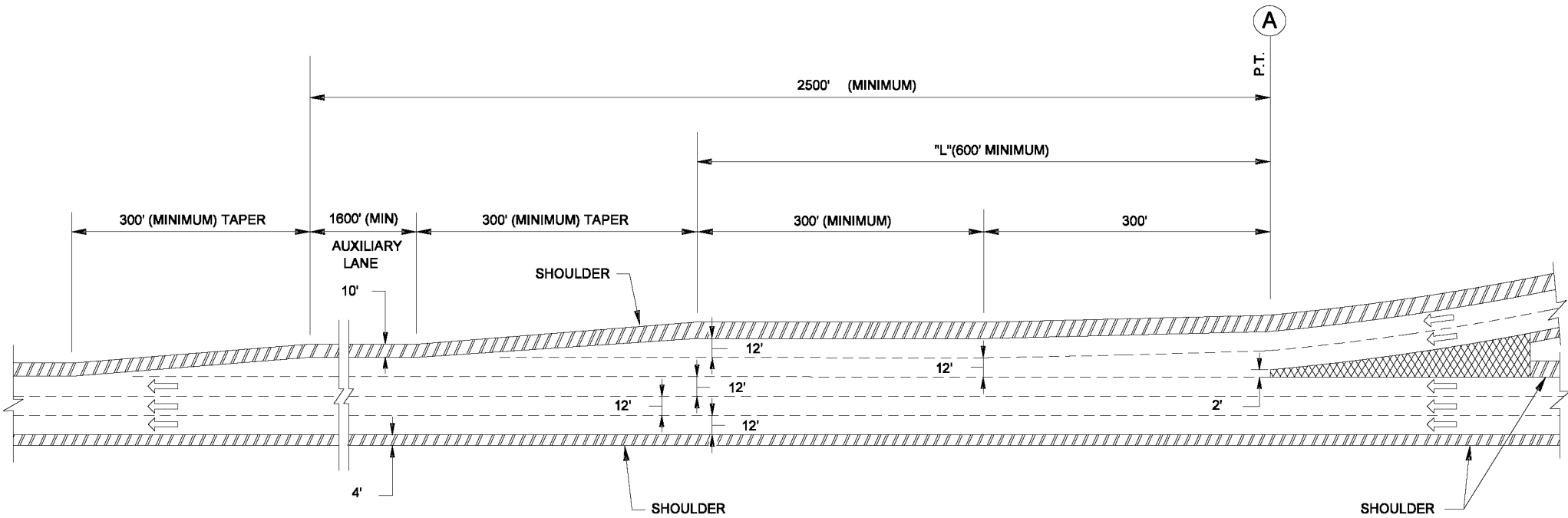

Notes:

1. L is the required acceleration length as shown in Figures 48-4D and 48-4E.
L = 600' minimum.
2. A parallel-lane design should be used at multi-lane entrances. The design details are similar to those for a single-lane entrance. See Figure 48-4C and the INDOT Standard Drawings.

MULTI-LANE ENTRANCE RAMP
(Service Interchanges)

Figure 48-4G

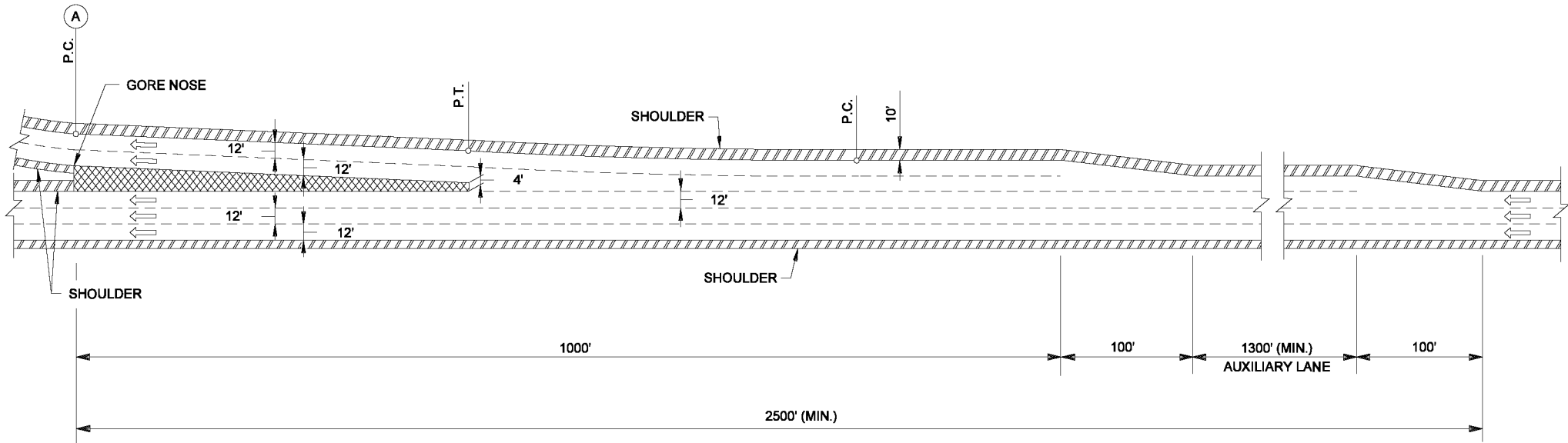

Note: A parallel-lane design should be used at multi-lane exits. The design details are similar to those for a single-lane exit. See Figure 48-4A and the INDOT Standard Drawings.

MULTI-LANE EXIT RAMP
(Service Interchanges)

Figure 48-4H

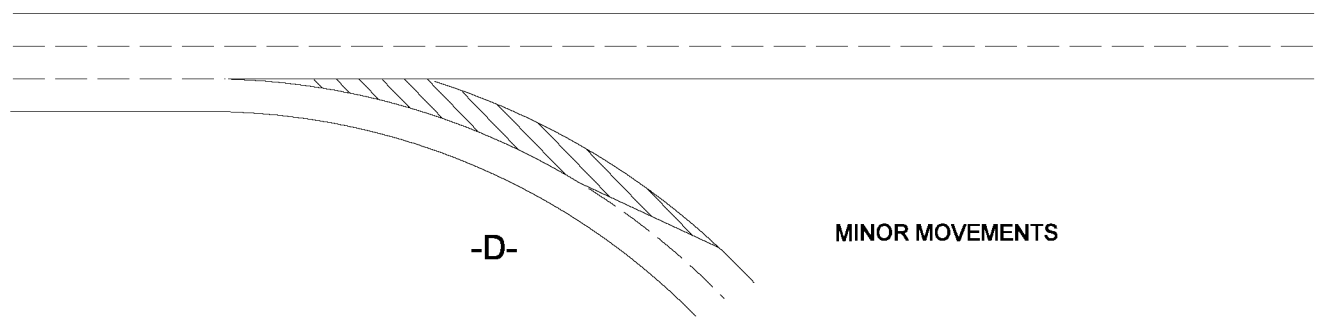
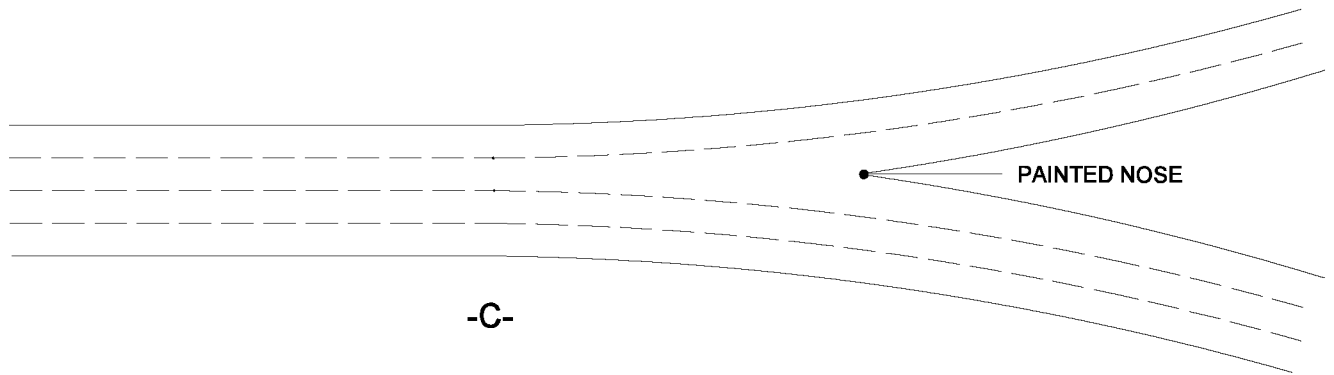
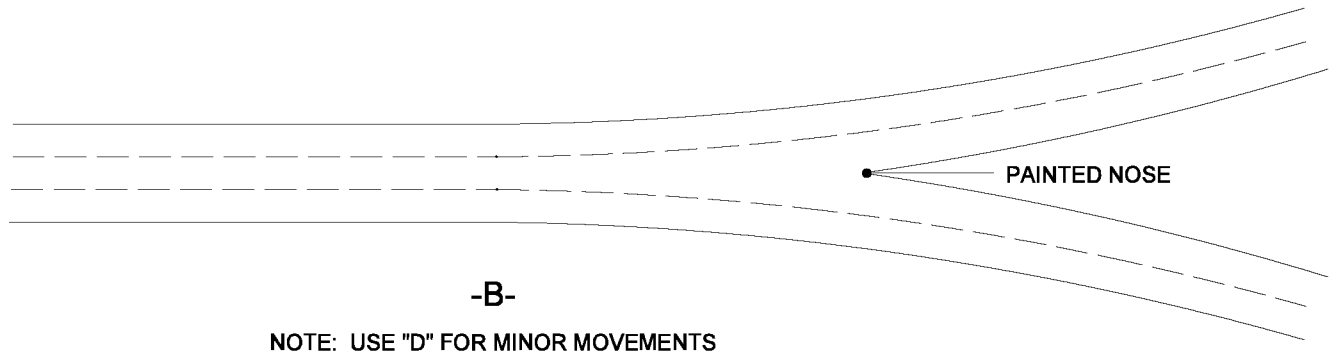
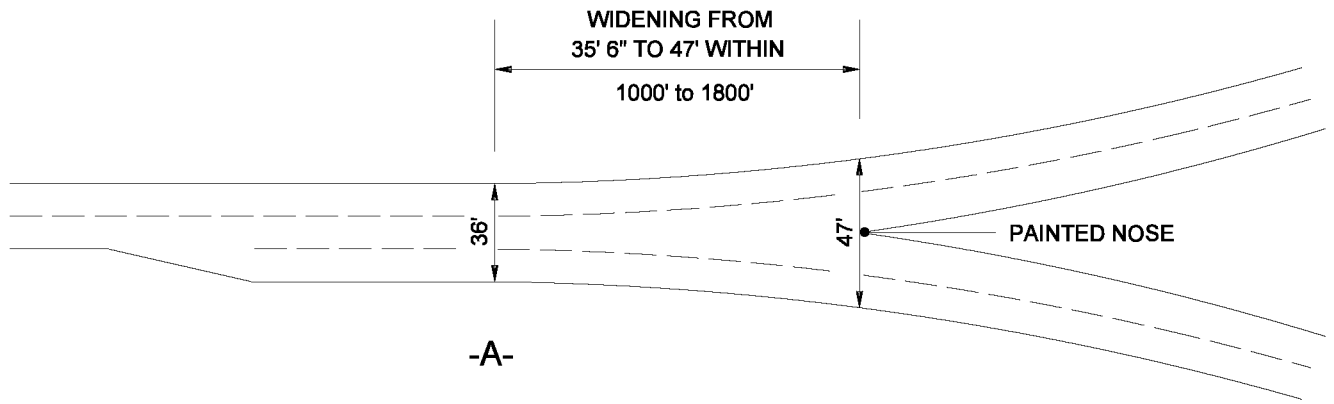

**MAJOR FORKS FOR SYSTEM INTERCHANGES
(Typical Schematics)**

Figure 48-41

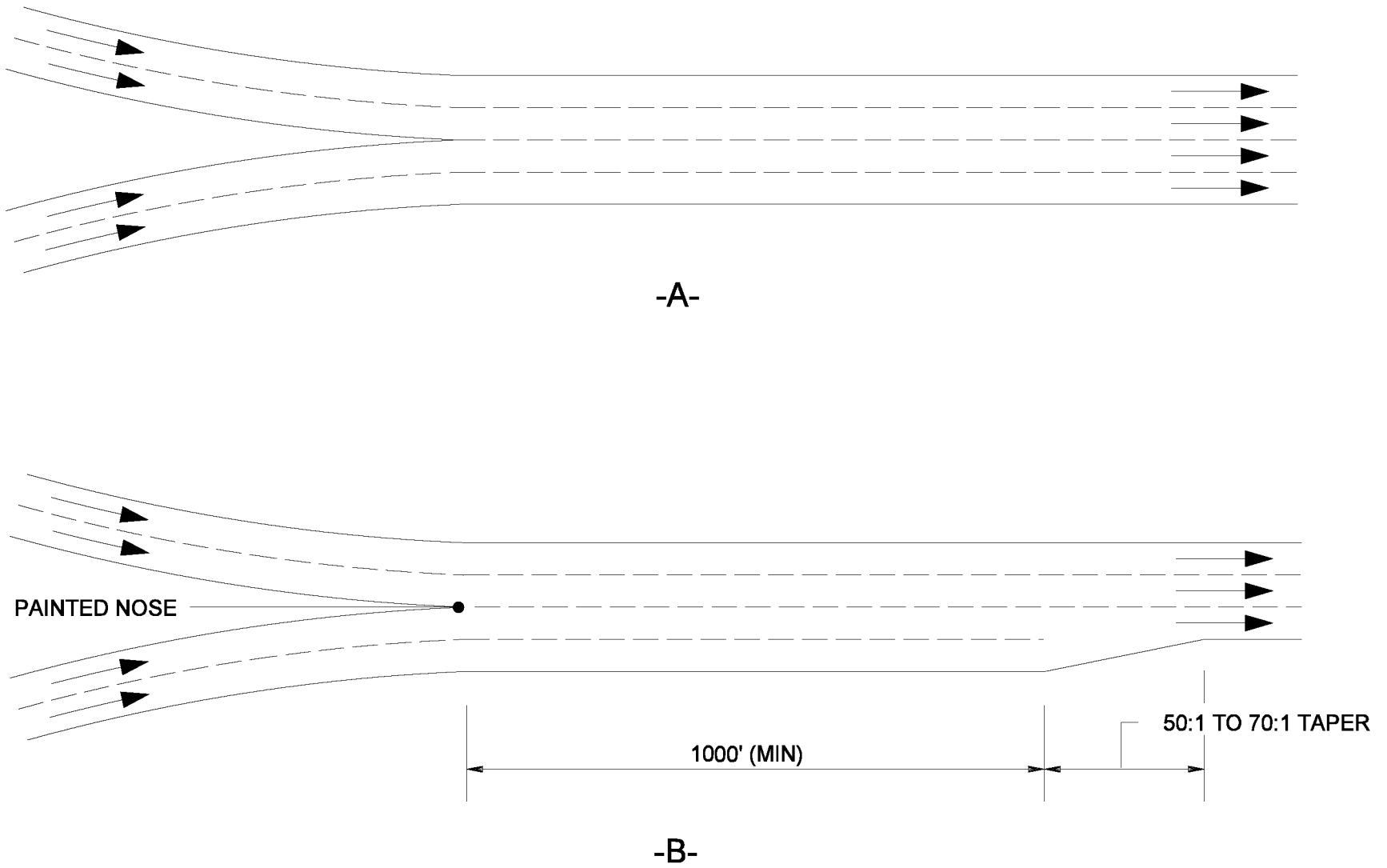

BRANCH CONNECTIONS FOR SYSTEM INTERCHANGES
(Typical Schematics)

Figure 48-4J

Mainline Design Speed, mph *	30	35	40	45	50	55	60	65	70
Ramp Design Speed, mph									
Upper Range, 85%	25	30	35	40	45	48	50	55	60
Middle Range, 70%	20	25	30	33	35	40	45	45	50
Lower Range, 50%	15	18	20	23	25	28	30	30	35
Corresponding Minimum Radius, ft									
All ranges	25	50	90	150	230	310	430	540	660

* Only a value for 50 mph or higher may be applied to a freeway or expressway exit.

**RAMP DESIGN SPEED
AND CORRESPONDING MINIMUM RADIUS**

Figure 48-5A

R* (ft)	V = 25			V = 30			V = 40			V = 45			V = 50			V = 55			V = 60		
	e	L (ft)		e	L (ft)		e	L (ft)		e	L (ft)		e	L (ft)		e	L (ft)		e	L (ft)	
		A	B		A	B		A	B		A	B		A	B		A	B		A	B
23000	NC	0	0	NC	0	0	NC	0	0	NC	0	0	NC	0	0	NC	0	0	NC	0	0
16400	NC	0	0	NC	0	0	NC	0	0	NC	0	0	NC	0	0	NC	0	0	NC	0	0
13120	NC	0	0	NC	0	0	NC	0	0	NC	0	0	NC	0	0	NC	0	0	NC	0	0
9840	NC	0	0	NC	0	0	NC	0	0	NC	0	0	NC	0	0	NC	0	0	RC	80	80
6560	NC	0	0	NC	0	0	NC	0	0	NC	0	0	RC	80	80	0.022	80	80	0.026	80	80
4920	NC	0	0	NC	0	0	NC	0	0	RC	80	80	0.024	80	80	0.028	80	80	0.034	80	100
4100	NC	0	0	NC	0	0	RC	80	80	0.023	80	80	0.028	80	80	0.033	80	100	0.040	80	120
3280	NC	0	0	RC	80	80	0.022	80	80	0.028	80	80	0.034	80	100	0.040	80	120	0.048	100	140
2960	NC	0	0	RC	80	80	0.024	80	80	0.031	80	80	0.037	80	100	0.044	80	120	0.052	100	140
2620	NC	0	0	RC	80	80	0.027	80	80	0.034	80	80	0.041	80	100	0.048	80	140	0.057	120	160
2300	RC	80	80	0.022	80	80	0.030	80	80	0.038	80	100	0.045	80	120	0.053	100	140	0.063	120	180
1960	RC	80	80	0.026	80	80	0.034	80	80	0.043	80	100	0.051	100	140	0.060	120	160	0.069	140	200
1640	0.022	80	80	0.030	80	80	0.039	80	80	0.049	80	120	0.058	100	140	0.067	120	180	0.076	140	220
1320	0.027	80	80	0.036	80	80	0.047	80	100	0.057	100	140	0.066	120	160	0.075	140	200	0.080	160	220
1140	0.030	80	80	0.040	80	80	0.051	80	120	0.062	100	140	0.071	120	180	0.079	140	220	Rmin = 1300		
1000	0.034	80	80	0.045	80	100	0.056	80	120	0.067	100	160	0.076	140	200	Rmin = 1000					
820	0.040	80	80	0.051	80	100	0.062	100	140	0.073	120	180	0.079	140	200	Rmin = 760					
740	0.043	80	80	0.054	80	100	0.066	100	140	0.076	120	180	Rmin = 600								
660	0.046	80	80	0.058	80	120	0.070	100	160	0.079	120	180	Rmin = 410								
580	0.050	80	100	0.062	80	120	0.074	120	160	Rmin = 280											
500	0.054	80	100	0.067	100	140	0.078	120	160	Rmin = 180											
420	0.059	80	120	0.072	100	140	0.080	120	180	Rmin = 180											
320	0.065	80	120	0.078	100	160	Rmin = 180														
300	0.069	80	120	0.079	100	160	Rmin = 180														
260	0.072	100	140	Rmin = 180																	
220	0.075	100	140	Rmin = 180																	
200	0.078	100	140	Rmin = 180																	

* For curve radius intermediate between listed values, use a straight-line interpolation to determine superelevation rate.

$e_{max} = 8\%$

- Key:
- R = Radius of curve
 - V = Ramp design speed (mph)
 - e = Superelevation rate
 - L = Length of superelevation runoff (from adverse crown removed to full superel.)
 - A = L for 1-way ramp rotated about the centerline of the travelway
 - B = L for 2-lane ramp rotated about the centerline of the travelway
 - NC = Normal crown
 - RC = Remove (adverse) crown

SUPERELEVATION RATE
(Interchange Ramp)
Figure 48-5B

R* (ft)	V = 25			V = 30			V = 40			V = 45			V = 50			V = 55			V = 60				
	e	L (ft)		e	L (ft)		e	L (ft)		e	L (ft)		e	L (ft)		e	L (ft)		e	L (ft)			
		A	B		A	B		A	B		A	B		A	B		A	B					
23000	NC	0	0	NC	0	0	NC	0	0	NC	0	0	NC	0	0	NC	0	0	NC	0	0		
16400	NC	0	0	NC	0	0	NC	0	0	NC	0	0	NC	0	0	NC	0	0	NC	0	0		
13120	NC	0	0	NC	0	0	NC	0	0	NC	0	0	NC	0	0	NC	0	0	NC	0	0		
9840	NC	0	0	NC	0	0	NC	0	0	NC	0	0	NC	0	0	NC	0	0	RC	80	80		
6560	NC	0	0	NC	0	0	NC	0	0	NC	0	0	RC	80	80	0.021	80	80	0.025	80	80		
4920	NC	0	0	NC	0	0	NC	0	0	RC	80	80	0.022	80	80	0.027	80	80	0.031	80	100		
4100	NC	0	0	NC	0	0	RC	80	80	0.022	80	80	0.026	80	80	0.031	80	80	0.036	80	100		
3280	NC	0	0	RC	80	80	0.021	80	80	0.026	80	80	0.031	80	80	0.036	80	100	0.042	80	120		
2960	NC	0	0	RC	80	80	0.023	80	80	0.028	80	80	0.034	80	100	0.039	80	100	0.045	80	120		
2620	NC	0	0	RC	80	80	0.025	80	80	0.031	80	80	0.036	80	100	0.042	80	120	0.049	100	140		
2300	RC	80	80	0.021	80	80	0.028	80	80	0.034	80	80	0.040	80	100	0.046	80	120	0.052	100	140		
1960	RC	80	80	0.024	80	80	0.031	80	80	0.038	80	100	0.043	80	120	0.050	100	140	0.056	100	160		
1640	0.021	80	80	0.028	80	80	0.035	80	80	0.042	80	100	0.048	80	120	0.054	100	140	0.059	120	160		
1320	0.025	80	80	0.033	80	80	0.040	80	100	0.047	80	120	0.053	100	140	0.059	100	160	Rmin = 1440				
1140	0.028	80	80	0.035	80	80	0.043	80	100	0.050	80	120	0.056	100	140	0.060	120	160					
1000	0.031	80	80	0.039	80	80	0.046	80	100	0.054	80	120	0.059	100	160	Rmin = 1120							
820	0.035	80	80	0.042	80	80	0.050	80	120	0.057	100	140	Rmin = 840						e _{max} = 6%				
740	0.037	80	80	0.044	80	80	0.053	80	120	0.059	100	140											
660	0.039	80	80	0.047	80	100	0.055	80	120	0.060	100	140											
580	0.041	80	80	0.050	80	100	0.058	80	120	Rmin = 640													
500	0.044	80	80	0.053	80	100	0.060	100	140														
420	0.047	80	80	0.056	80	120	Rmin = 440																
320	0.052	80	100	0.060	80	120																	
300	0.054	80	100	0.060	80	120																	
260	0.056	80	100	Rmin = 300																			
220	0.058	80	100																				
200	0.060	80	120																				
Rmin = 180																							

Key: R = Radius of curve
V = Ramp design speed (mph)
e = Superelevation rate
L = Length of superelevation runoff (from adverse crown removed to full super)
A = "L" for 1-way ramp rotated about the centerline of the travelway
B = "L" for 2-lane ramp rotated about the centerline of the travelway
NC = Normal crown
RC = Remove (adverse) crown

SUPERELEVATION RATE
(Interchange Ramp)
Figure 48-5C

*For curve radius intermediate between listed values, use a straight-line interpolation to determine the superelevation rate.

R* (ft)	V = 25			V = 30			V = 40			V = 45			V = 50			V = 55			V = 60		
	e	L (ft)		e	L (ft)		e	L (ft)		e	L (ft)		e	L (ft)		e	L (ft)		e	L (ft)	
		A	B		A	B		A	B		A	B		A	B		A	B			
23000	NC	0	0	NC	0	0	NC	0	0	NC	0	0	NC	0	0	NC	0	0	NC	0	0
16400	NC	0	0	NC	0	0	NC	0	0	NC	0	0	NC	0	0	NC	0	0	NC	0	0
13120	NC	0	0	NC	0	0	NC	0	0	NC	0	0	NC	0	0	NC	0	0	NC	0	0
9840	NC	0	0	NC	0	0	NC	0	0	NC	0	0	NC	0	0	NC	0	0	RC	60	60
6560	NC	0	0	NC	0	0	NC	0	0	NC	0	0	RC	80	80	RC	80	80	0.022	60	60
4920	NC	0	0	NC	0	0	NC	0	0	RC	80	80	RC	80	80	0.023	80	80	0.026	60	60
4100	NC	0	0	NC	0	0	RC	80	80	RC	80	80	0.022	80	80	0.026	80	80	0.029	60	60
3280	NC	0	0	NC	80	80	RC	80	80	0.022	80	80	0.025	80	80	0.028	80	80	0.032	60	100
2960	NC	0	0	RC	80	80	RC	80	80	0.024	80	80	0.027	80	80	0.030	80	80	0.034	60	100
2620	NC	0	0	RC	80	80	0.021	80	80	0.025	80	80	0.028	80	80	0.032	80	100	0.035	60	100
2300	NC	80	80	RC	80	80	0.023	80	80	0.027	80	80	0.030	80	80	0.034	80	100	0.037	60	100
1960	RC	80	80	0.021	80	80	0.025	80	80	0.029	80	80	0.032	80	80	0.036	80	100	0.039	60	120
1640	RC	80	80	0.023	80	80	0.027	80	80	0.031	80	80	0.035	80	100	0.038	80	100	0.040	60	120
1320	0.021	80	80	0.025	80	80	0.029	80	80	0.034	80	80	0.037	80	100	0.040	80	120	Rmin = 1620		
1140	0.023	80	80	0.027	80	80	0.031	80	80	0.036	80	80	0.039	80	100	Rmin = 1250					
1000	0.024	80	80	0.028	80	80	0.033	80	80	0.038	80	100	0.040	80	100						
820	0.026	80	80	0.030	80	80	0.036	80	80	0.039	80	100	Rmin = 920								
740	0.027	80	80	0.032	80	80	0.037	80	80	0.040	80	100									
660	0.028	80	80	0.033	80	80	0.038	80	80	Rmin = 710											
580	0.029	80	80	0.035	80	80	0.039	80	80												
500	0.031	80	80	0.037	80	80	0.040	80	100												
420	0.033	80	80	0.039	80	80	Rmin = 500														
320	0.036	80	80	0.040	80	80															
300	0.037	80	80	Rmin = 320																	
260	0.038	80	80																		
220	0.039	80	80																		
200	0.040	80	80																		
Rmin = 200																					

$e_{max} = 4\%$

- Key:
- R = Radius of curve
 - V = Ramp design speed (mph)
 - e = Superelevation rate
 - L = Length of superelevation runoff
(from adverse crown removed to full super)
 - A = "L" for 1-way ramp rotated about the centerline of the travelway
 - B = "L" for 2-lane ramp rotated about the centerline of the travelway
 - NC = Normal crown
 - RC = Remove (adverse) crown

*For curve radius intermediate between listed values, use a straight-line interpolation to determine the superelevation rate.

**SUPERELEVATION RATE
(Interchange Ramp)
Figure 48-5D**

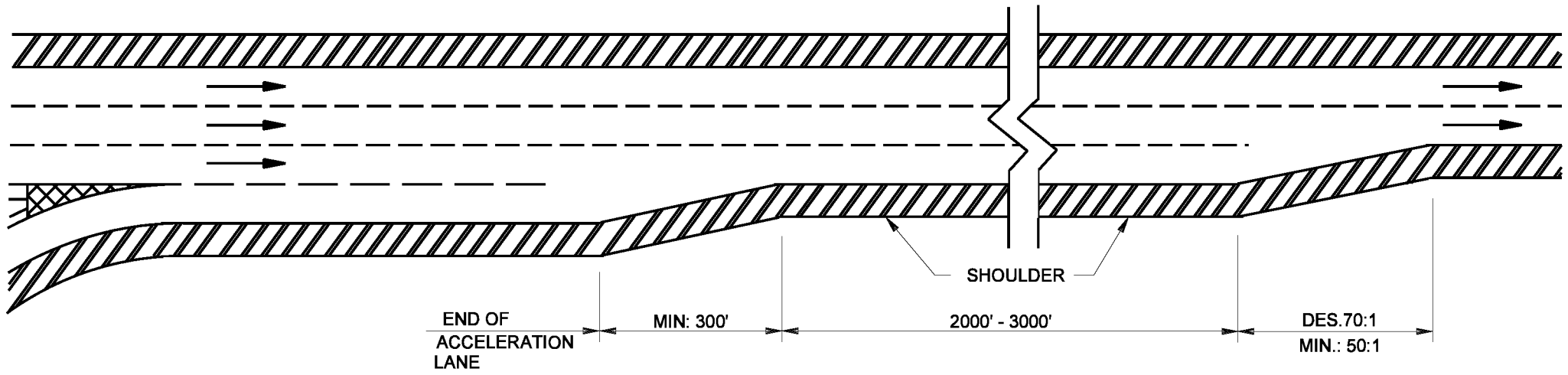

FREEWAY LANE DROP
(Typical Schematic)

Figure 48-6A

DES. 70:1
MIN.: 50:1

Frontage Road Volume (vph) ¹	Exit Ramp Volume (vph) ²	A (ft)		
		Typical Minimum	Typical Desirable	Special Conditions
200	140	380	500	260
400	275	460	560	360
600	410	500	630	400
800	550	540	690	430
1000	690	590	760	460
1200	830	640	870	480
1400	960	690	970	500
1600	1100	770	1070	530
1800	1240	860	1180	560
2000	1380	970	1300	590

¹ Total frontage road and exit ramp traffic volume between merge to intersection with minor road.

² Assumed to be 69% of total volume shown in first column.

Note: Table value is are acceptable for planning purposes. Final dimensions will be based on a detailed operational analysis. This design may only be used where necessary in a restricted urban area.

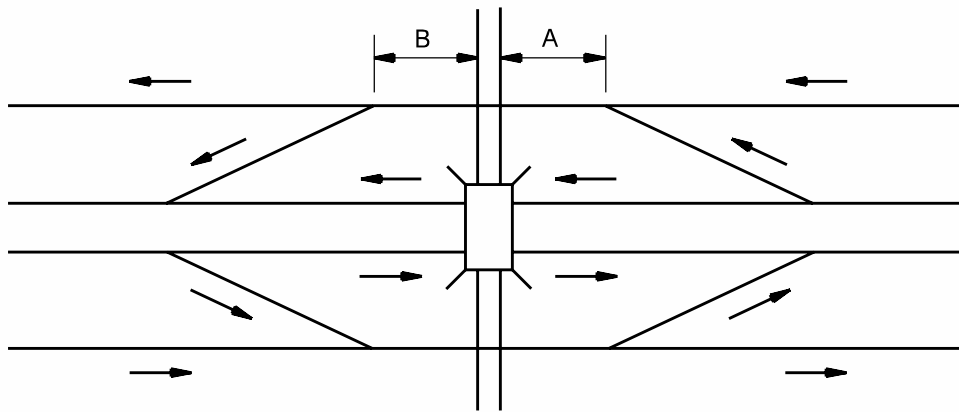

RAMP/CONTINUOUS FRONTAGE ROAD INTERSECTION

Figure B

RAMP AND CONTINUOUS FRONTAGE ROAD INTERSECTION

Figure 48-6B

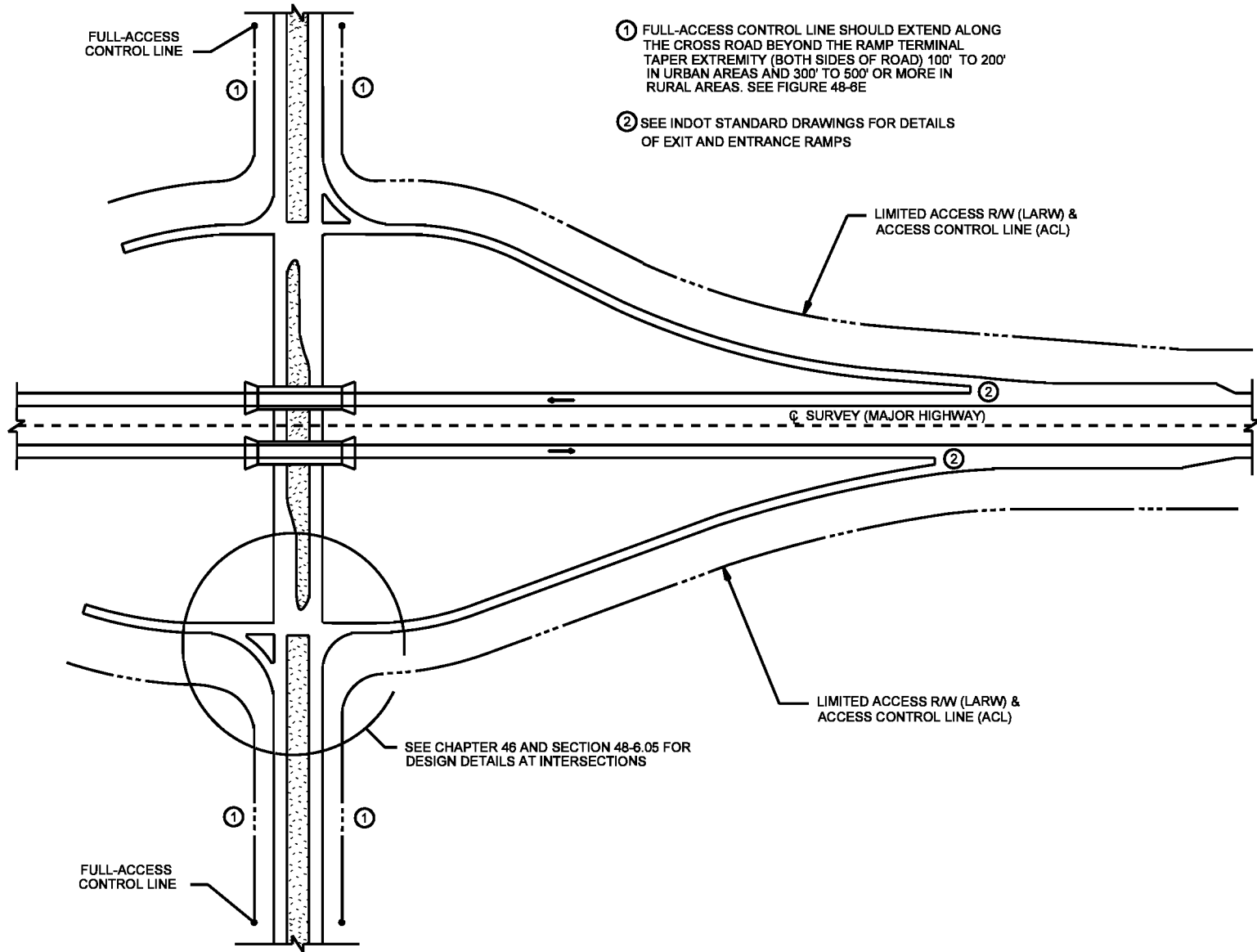

TYPICAL ACCESS CONTROL FOR A
DIAMOND INTERCHANGE

Figure 48-6C

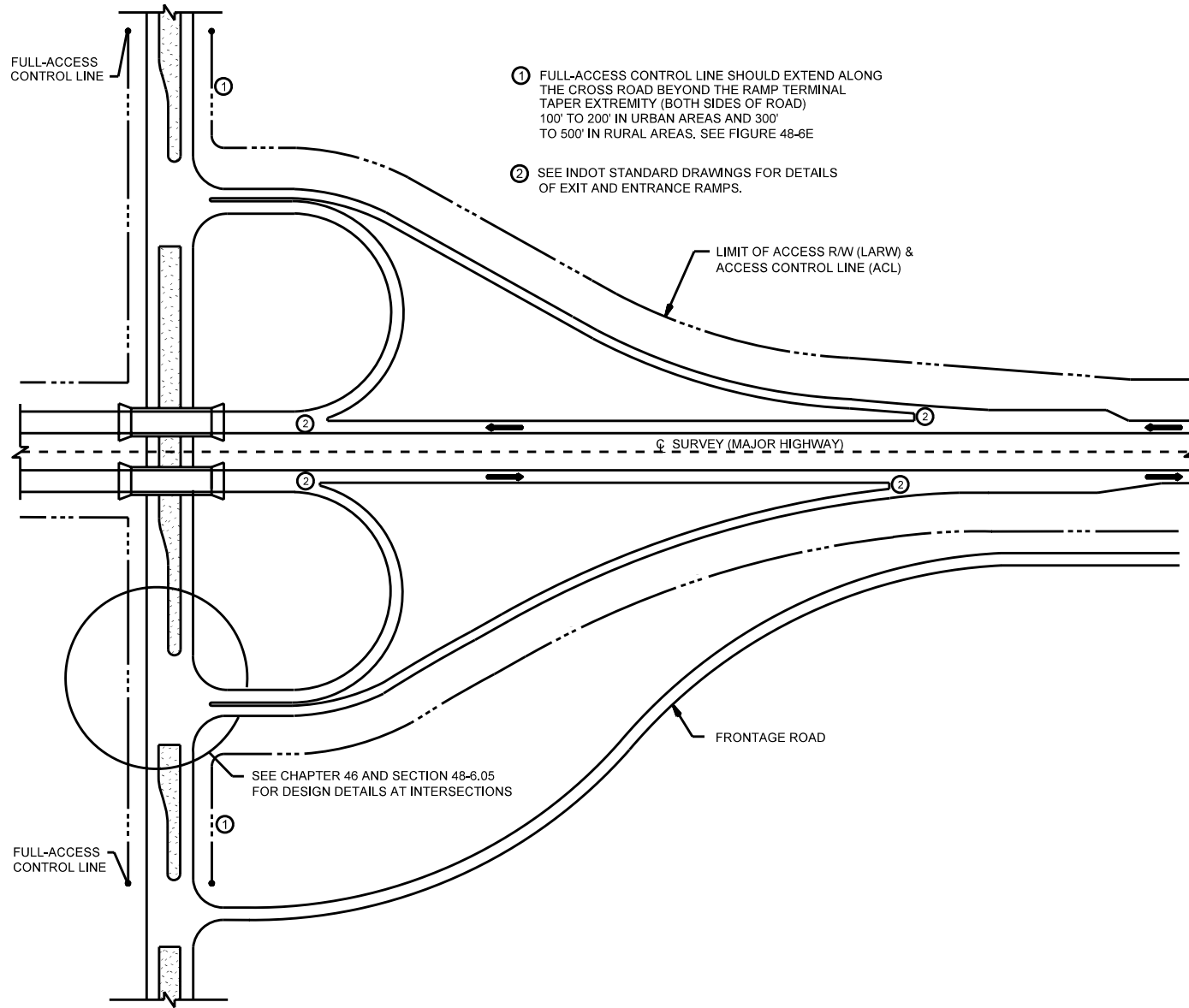

① FULL-ACCESS CONTROL LINE SHOULD EXTEND ALONG THE CROSS ROAD BEYOND THE RAMP TERMINAL TAPER EXTREMITY (BOTH SIDES OF ROAD) 100' TO 200' IN URBAN AREAS AND 300' TO 500' IN RURAL AREAS. SEE FIGURE 48-6E

② SEE INDOT STANDARD DRAWINGS FOR DETAILS OF EXIT AND ENTRANCE RAMPS.

LIMIT OF ACCESS R/W (LARW) & ACCESS CONTROL LINE (ACL)

☉ SURVEY (MAJOR HIGHWAY)

FRONTAGE ROAD

SEE CHAPTER 46 AND SECTION 48-6.05 FOR DESIGN DETAILS AT INTERSECTIONS

TYPICAL ACCESS CONTROL FOR A PARTIAL CLOVERLEAF INTERCHANGE (With Frontage Road)

Figure 48-6D

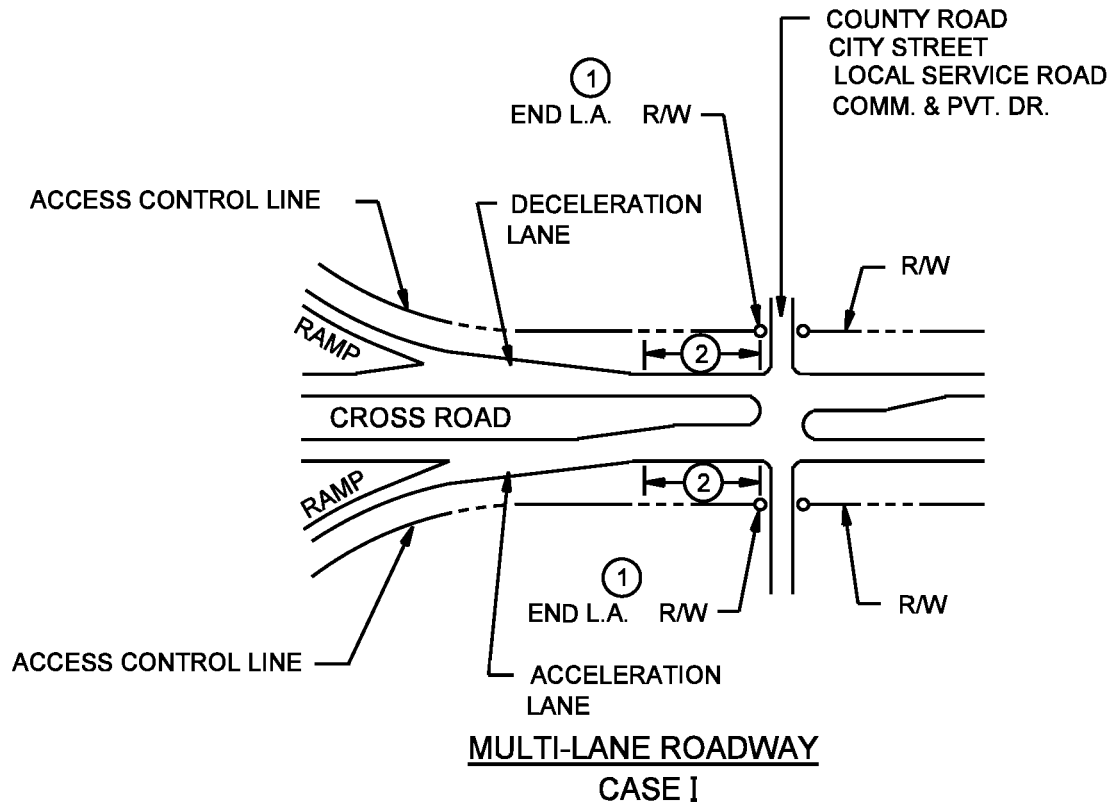

- ① FULL-ACCESS CONTROL LINE SHOULD EXTEND ALONG THE CROSS ROAD BEYOND THE RAMP TERMINAL TAPER EXTREMITY (BOTH SIDES OF ROAD) 100' TO 200' IN URBAN AREAS AND 300' TO 500' IN RURAL AREAS. THE END OF ACCESS CONTROL SHOULD BE AT OPPOSITE POINTS, WHERE FEASIBLE.
- ② IN CASE I and II THE AUXILIARY LANE TERMINATING THE GREATER DISTANCE FROM THE INTERCHANGE AREA SHOULD GOVERN.

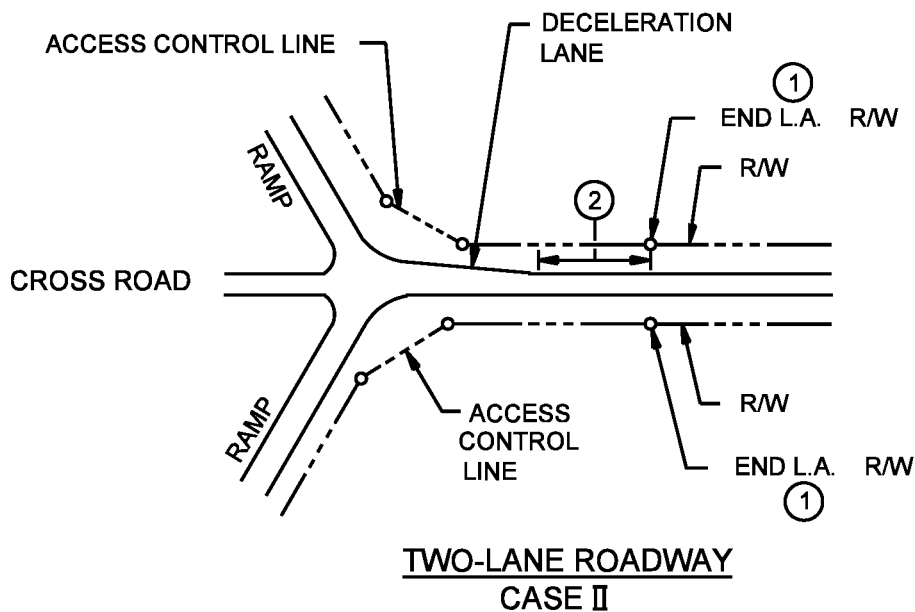

ACCESS CONTROL AT RAMP TERMINALS

Figure 48-6E