

**STATE OF INDIANA**  
**DEPARTMENT OF ENVIRONMENTAL MANAGEMENT**  
**PUBLIC NOTICE NO 20260506 – IN0025755– D**  
**DATE OF NOTICE: May 6, 2026**  
**DATE RESPONSE DUE: June 8, 2026**

The Office of Water Quality proposes the following **DRAFT NPDES PERMIT**:

**Major Renewal:**

**City of Goshen WWTP**, Permit IN0025755, ELKHART COUNTY, 1000 West Wilden Avenue, Goshen, IN. This major municipal wastewater treatment plant has an average design flow of 5 million gallons daily of treated sanitary and combined sewer wastewater into the Elkhart River via Outfall 001. Outfall 001 is located at Latitude: 41° 35' 48" N, Longitude: 85° 51' 11" W. Sludge at the facility is land-applied. Permit Manager: Jay Hanko at 317-233-0704 or [jhanko@idem.in.gov](mailto:jhanko@idem.in.gov). Posted online at <https://www.in.gov/idem/public-notices/>.

**PROCEDURES TO FILE A RESPONSE**

You are hereby notified of the availability of a 30-day public comment period regarding the referenced draft permit, in accordance with IC 13-15-5-1. The application and draft permit documents are available for inspection at IDEM, Office of Water Quality, Indiana Government Center North - Room 1255, 100 N. Senate Ave, Indianapolis, IN 46204 from 9:00 a.m. until 4:00 p.m., Monday thru Friday, (copies 10¢ per page). The Draft Permit is posted online on the above-referenced IDEM public notice web page. A courtesy copy has also been sent via email to the local County Health Department. Please tell others whom you think would be interested in this matter. For more information about public participation including your rights & responsibilities, please see <https://www.in.gov/idem/public-notices/>. You may want to consult our online Citizens' Guide to IDEM: <https://www.in.gov/idem/resources/citizens-guide-to-idem/>.

**Comments:** The proposed decision to issue a permit is tentative. Interested persons are invited to submit written comments on the draft permit. All comments must be delivered to IDEM or postmarked no later than the Response Due Date noted to be considered in the decision to issue a final permit. Deliver or mail all requests or comments to the attention of the Permit Manager at the above address. **To Request a Public Hearing:** Any person may request a public hearing. A written request must be submitted to the above address on or before the Response Due Date. The written request shall include: the name and address of the person making the request, the interest of the person making the request, persons represented by the person making the request, the reason for the request and the issues proposed for consideration at the hearing. The Department will determine whether to hold a public hearing based upon the comments and the rationale for the request. Public Notice of such a hearing will be posted on IDEM's web site for public notices and notification will also be sent out to those persons submitting comments and/or on the mailing list at least 30 days prior to the hearing.



## INDIANA DEPARTMENT OF ENVIRONMENTAL MANAGEMENT

100 N. Senate Avenue • Indianapolis, IN 46204  
(800) 451-6027 • (317) 232-8603 • Fax (317) 233-6647 • [www.idem.IN.gov](http://www.idem.IN.gov)

**Mike Braun**  
Governor

**Clint Woods**  
Commissioner

May 6, 2026

### VIA ELECTRONIC MAIL

The Honorable Gina Leichy, Mayor  
City of Goshen  
202 S. 5th Street, Suite 1  
Goshen, Indiana 46528

Dear Mayor Leichy:

Re: Draft NPDES Permit No. IN0025755  
The City of Goshen Wastewater Treatment Plant  
Goshen County

Your application and supporting documents have been reviewed and processed in accordance with rules adopted under 327 IAC 5. Enclosed is draft NPDES Permit No. IN0025755 which applies to the discharge from the City of Goshen Wastewater Treatment Plant.

Pursuant to IC 13-15-5-1, IDEM will publish the draft permit document online at <https://www.in.gov/idem/public-notices/>. Additional information on public participation can be found in the "Citizens' Guide to IDEM", available at <https://www.in.gov/idem/resources/citizens-guide-to-idem/>. A 30-day comment period is available to solicit input from interested parties, including the general public.

Please review this document carefully and become familiar with the proposed terms and conditions. Comments concerning the draft permit should be submitted in accordance with the procedure outlined in the enclosed public notice form. Questions concerning this draft permit may be addressed to Jay Hanko at 317/233-0704 or [Jhanko@idem.IN.gov](mailto:Jhanko@idem.IN.gov).

Sincerely,

Leigh Voss, Chief  
Municipal NPDES Permits Section  
Office of Water Quality

Enclosures

cc: Jim Kerezman, Superintendent



STATE OF INDIANA  
DEPARTMENT OF ENVIRONMENTAL MANAGEMENT  
AUTHORIZATION TO DISCHARGE UNDER THE  
NATIONAL POLLUTANT DISCHARGE ELIMINATION SYSTEM

In compliance with the provisions of the Federal Water Pollution Control Act, as amended, (33 U.S.C. 1251 et seq., the "Clean Water Act") or (CWA), and IDEM's authority under IC 13-15, the Indiana Department of Environmental Management (IDEM) is issuing this permit to the

**CITY OF GOSHEN**

hereinafter referred to as "the permittee." The permittee owns and/or operates the **City of Goshen Wastewater Treatment Plant**, a major municipal wastewater treatment plant located at 1000 West Wilden Avenue, Goshen, Indiana, Elkhart County. The permittee is hereby authorized to discharge from the outfalls identified in Part I of this permit to receiving waters named the Elkhart River, located within the Lake Michigan drainage basin, in accordance with the effluent limitations, monitoring requirements, and other conditions set forth in the permit. This permit may be revoked for the nonpayment of applicable fees in accordance with IC 13-18-20.

Effective Date: \_\_\_\_\_.

Expiration Date: \_\_\_\_\_.

In order to receive authorization to discharge beyond the date of expiration, the permittee shall submit such information and application forms as are required by the Indiana Department of Environmental Management. The application shall be submitted to IDEM at least 180 days prior to the expiration date of this permit, unless a later date is allowed by the Commissioner in accordance with 327 IAC 5-3-2 and Part II.A.4 of this permit.

Issued on \_\_\_\_\_, for the Indiana Department of Environmental Management.

Jerry Dittmer, Chief  
Permits Branch  
Office of Water Quality

TREATMENT FACILITY DESCRIPTION

The permittee currently operates a Class III, 5.0 MGD treatment facility consisting of two (2) bar screens, an influent flow meter, grit removal, six (6) primary clarifiers, five (5) activated sludge aeration tanks, two (2) secondary clarifiers, phosphorus removal, chlorination disinfection, an effluent flow meter, two (2) final clarifiers, and dechlorination. Sludge is treated by two (2) anaerobic digesters. Final sludge disposal via landfill.

The collection system is comprised of combined sanitary and storm sewers with four (4) Combined Sewer Overflow (CSO) locations. The CSO locations have been identified and are subject to the provisions in Attachment A of the permit.

The mass limits for CBOD<sub>5</sub>, TSS, TRC, and ammonia-nitrogen have been calculated utilizing the peak design flow of 12.5 MGD. This is to facilitate the maximization of flow through the treatment facility in accordance with this Office's CSO policy.

PART I

A. EFFLUENT LIMITATIONS AND MONITORING REQUIREMENTS

The permittee is authorized to discharge from the outfall listed below in accordance with the terms and conditions of this permit. The permittee shall take samples and measurements at a location representative of each discharge to determine whether the effluent limitations have been met. Refer to Part I.B of this permit for additional monitoring and reporting requirements.

1. Beginning on the effective date of this permit, the permittee is authorized to discharge from Outfall 001, which is located at Latitude: 41° 35' 48" N, Longitude: 85° 51' 11" W. The discharge is subject to the following requirements:

TABLE 1

Parameter	Quantity or Loading			Quality or Concentration			Monitoring Requirements	
	Monthly Average	Weekly Average	Units	Monthly Average	Weekly Average	Units	Measurement Frequency	Sample Type
Flow [1]	Report	----	MGD	----	----	----	5 X Weekly	24-Hr. Total
CBOD <sub>5</sub>	2,608	4,173	lbs/day	25	40	mg/l	5 X Weekly	24-Hr. Comp.
TSS	3,129	4,694	lbs/day	30	45	mg/l	5 X Weekly	24-Hr. Comp.
Total Phosphorus [2]	Report	----	lbs/day	1.0	----	mg/l	5 X Weekly	24-Hr. Comp.
Nitrogen, Total (as N) [3]	Report	----	lbs/day	Report	----	mg/l	Monthly	24-Hr. Comp.

TABLE 2

Parameter	Quality or Concentration				Monitoring Requirements	
	Daily Minimum	Monthly Average	Daily Maximum	Units	Measurement Frequency	Sample Type
pH [4]	6.0	----	9.0	s.u.	5 X Weekly	Grab
Dissolved Oxygen [5]	4.0	----	----	mg/l	5 X Weekly	3 Grabs/24-Hrs.
<i>E.coli</i> [6][7]	----	125 [8]	235 [9]	cfu/100 ml	5 X Weekly	Grab

TABLE 3

Parameter	Quantity or Loading			Quality or Concentration			Monitoring Requirements	
	Monthly Average	Daily Maximum	Units	Monthly Average	Daily Maximum	Units	Measurement Frequency	Sample Type
Ammonia-nitrogen								
Summer [10]	323	751	lbs/day	3.1	7.2	mg/l	5 X Weekly	24-Hr. Comp.
Winter [11]	605	1,387	lbs/day	5.8	13.3	mg/l	5 X Weekly	24-Hr. Comp.
Total Residual Chlorine [6]								
Final [12]	2.1	4.2	lbs/day	0.02	0.04	mg/l	5 X Weekly	Grab
Whole Influent Toxicity [13]								
Acute	----	----	----	----	1.0	TU <sub>a</sub>	2 X Annually	24-Hr. Comp.
Chronic	----	----	----	3.8	----	TU <sub>c</sub>	2 X Annually	24-Hr. Comp.

[1] Effluent flow measurement is required per 327 IAC 5-2-13. The flow meter(s) shall be calibrated at least once every twelve months.

[2] In accordance with 327 IAC 5-10-2(b), the facility must produce an effluent containing no more than 1.0 mg/l total phosphorus (P) any month that the average total phosphorus level in the raw sewage is greater than 5 mg/l. Otherwise, a degree of reduction, as prescribed below, must be achieved. Such reduction is to be calculated based on monthly average raw and final concentrations.

Phosphorus (P) Level in Raw Sewage (mg/l)	Required Removal (%)
greater than or equal to 4	80%
less than 4, greater than or equal to 3	75%
less than 3, greater than or equal to 2	70%
less than 2, greater than or equal to 1	65%
less than 1	60%

[3] Total Nitrogen shall be determined by testing Total Kjeldahl Nitrogen (TKN) and Nitrate + Nitrite and reporting the sum of the TKN and Nitrate + Nitrite results (reported as N). Nitrate + Nitrite can be analyzed together or separately. Monitoring for Total Nitrogen is required in the effluent only.

The following EPA methods are recommended for use in the analysis of TKN and Nitrate + Nitrite. Alternative approved 40 CFR 136 methods may be utilized.

<u>Parameter</u>	<u>Method</u>
TKN	350.1, 351.1, 351.2
Nitrate	300.0, 300.1, 352.1
Nitrite	300.1, 353.2
Nitrate + Nitrite	300.0, 300.1, 353.2

- [4] If the permittee collects more than one grab sample on a given day for pH, the values shall not be averaged for reporting daily maximums or daily minimums. The permittee must report the individual minimum and the individual maximum pH value of any sample during the month on the Monthly Report of Operation forms.
- [5] The daily minimum concentration of dissolved oxygen in the effluent shall be reported as the arithmetic mean determined by summation of the three (3) daily grab sample results divided by the number of daily grab samples. These samples are to be collected over equal time intervals.
- [6] The *Escherichia coli* (*E. coli*) limitations apply from April 1 through October 31 annually.
- [7] The effluent shall be disinfected on a continuous basis such that violations of the applicable bacteriological limitations (*E. coli*) do not occur from April 1 through October 31, annually. If the permittee uses chlorine for any reason, at any time including the period from November 1 through March 31, then the limits and monitoring requirements in Table 2 and 3 for Total Residual Chlorine (TRC) shall be in effect whenever chlorine is used.
- [8] The monthly average *E. coli* value shall be calculated as a geometric mean. Per 327 IAC 5-10-6, the concentration of *E. coli* shall not exceed one hundred twenty-five (125) cfu or mpn per 100 milliliters as a geometric mean of the effluent samples taken in a calendar month. No samples may be excluded when calculating the monthly geometric mean.
- [9] If less than ten samples are taken and analyzed for *E. coli* in a calendar month, no samples may exceed two hundred thirty-five (235) cfu or mpn as a daily maximum. However, when ten (10) or more samples are taken and analyzed for *E. coli* in a calendar month, not more than ten percent (10%) of those samples may exceed two hundred thirty-five (235) cfu or mpn as a daily maximum. When calculating ten percent, the result must not be rounded up. In reporting for compliance purposes on the Discharge Monitoring Report (DMR) form, the permittee shall record the highest non-excluded value for the daily maximum.
- [10] Summer limitations apply from May 1 through November 30 of each year.
- [11] Winter limitations apply from December 1 through April 30 of each year.
- [12] The monthly average Water Quality-Based Effluent Limit (WQBEL) for total residual chlorine is less than the Limit of Quantitation (LOQ) as specified below. Compliance

with the total residual chlorine concentration limitations will be demonstrated if the monthly average effluent level is less than or equal to the monthly average WQBEL. For the purpose of calculating the monthly average value, the daily effluent values that are less than the LOQ may be assigned a value of zero (0), unless, after considering the number of monitoring results that are greater than the Limit of Detection (LOD), and applying appropriate statistical techniques, a value other than zero (0) is warranted.

The daily maximum WQBEL for total residual chlorine is greater than or equal to the LOD value, but less than the LOQ value specified in the permit. Compliance with this effluent limitation will be demonstrated if the measured daily effluent concentrations are less than the LOQ. For daily maximum mass limitations based on WQBELs which are less than the LOQ value, compliance with the daily maximum mass value is based on the LOQ value. Compliance with the daily maximum mass value will be demonstrated if the calculated mass value is less than 4.2 lbs/day.

At present, two methods are acceptable to IDEM measure total residual chlorine: amperometric and DPD colorimetric methods.

Parameter	LOD	LOQ
Chlorine	0.02 mg/l	0.06 mg/l

#### Case-Specific MDL

The permittee may determine a case-specific Method Detection Level (MDL) using the analytical method specified above. The MDL shall be derived by the procedure specified for MDLs contained in 40 CFR Part 136, Appendix B, and the limit of quantitation shall be set equal to 3.18 times the MDL. Other methods may be used if first approved by the U.S. EPA and IDEM.

- [13] Please refer to Part I.D. of this permit for Whole Effluent Toxicity requirements. The permittee is to report the more stringent of the results for the two test species (Fathead Minnow or *Ceriodaphnia dubia*) on the Discharge Monitoring Report forms. Please note that complete Whole Effluent Toxicity reports are required to be submitted to this Office's Compliance Data Section. In the event that the permittee is required to implement a toxicity reduction evaluation (TRE), WET monitoring frequencies will revert to the schedule outlined in Part I.D.2.e.

2. Minimum Narrative Limitations

At all times the discharge from any and all point sources specified within this permit shall not cause receiving waters:

- a. including waters within the mixing zone, to contain substances, materials, floating debris, oil, scum attributable to municipal, industrial, agricultural, and other land use practices, or other discharges that do any of the following:
  - (1) will settle to form putrescent or otherwise objectionable deposits;
  - (2) are in amounts sufficient to be unsightly or deleterious;
  - (3) produce color, visible oil sheen, odor, or other conditions in such degree as to create a nuisance;
  - (4) are in amounts sufficient to be acutely toxic to, or to otherwise severely injure or kill aquatic life, other animals, plants, or humans;
  - (5) are in concentrations or combinations that will cause or contribute to the growth of aquatic plants or algae to such a degree as to create a nuisance, be unsightly, or otherwise impair the designated uses.
- b. outside the mixing zone, to contain substances in concentrations that on the basis of available scientific data are believed to be sufficient to injure, be chronically toxic to, or be carcinogenic, mutagenic, or teratogenic to humans, animals, aquatic life, or plants.

3. Additional Discharge Limitations and Monitoring Requirements

Beginning on the effective date of the permit, the effluent from Outfall 001 shall be limited and monitored by the permittee as follows:

TABLE 4

Parameter	Quantity or Loading			Quality or Concentration			Monitoring Requirements	
	Monthly Average	Daily Maximum	Units	Monthly Average	Daily Maximum	Units	Measurement Frequency	Sample Type
Cadmium [1]	----	Report	lbs/day	----	Report	mg/l	1 X Quarterly	24 Hr. Comp.
Chromium[1]	----	Report	lbs/day	----	Report	mg/l	1 X Quarterly	24 Hr. Comp.
Copper [1][2]								
Interim	Report	Report	lbs/day	Report	Report	mg/l	1 X Weekly	24 Hr. Comp.
Final	1.7	3.4	lbs/day	0.041	0.082	mg/l	1 X Weekly	24 Hr. Comp.
Cyanide [1]	----	Report	lbs/day	----	Report	mg/l	1 X Quarterly	Grab
Lead [1]	----	Report	lbs/day	----	Report	mg/l	1 X Quarterly	24 Hr. Comp.
Mercury [1][3][4]								
Interim Limit [5]	----	----	lbs/day	2.23 [6]	----	ng/l	6 X Annually	Grab
WQBELs	0.000054	0.00013	lbs/day	1.3	3.2	ng/l	6 X Annually	Grab
Nickel [1]	----	Report	lbs/day	----	Report	mg/l	1 X Quarterly	24 Hr. Comp.
Selenium [1][2]								
Interim	Report	Report	lbs/day	Report	Report	mg/l	1 X Weekly	24 Hr. Comp.
Final	0.13	0.31	lbs/day	0.0031	0.0075	mg/l	1 X Weekly	24 Hr. Comp.
Silver[1][2]								
Interim	Report	Report	lbs/day	Report	Report	mg/l	1 X Weekly	24 Hr. Comp.
Final	0.0074	0.015	lbs/day	0.00018	0.00036	mg/l	1 X Weekly	24 Hr. Comp.
Zinc [1]	----	Report	lbs/day	----	Report	mg/l	1 X Quarterly	24 Hr. Comp.

NOTE: For measurement frequencies less than once per month, the permittee shall report the result from the monitoring period on the Discharge Monitoring Report (DMR) for the final month of the reporting timeframe, beginning with January of each year. For example, for quarterly monitoring, the permittee may conduct sampling within the month of January, February or March. The result from this reporting timeframe shall be reported on the March DMR, regardless of which of the months within the quarter the sample was taken.

[1] The permittee shall measure and report this parameter as Total Recoverable Metal. Cyanide shall be reported as Free Cyanide.

The following EPA test methods and/or Standard Methods and associated Limits of Detection (LODs) and Limits of Quantitation (LOQs) are recommended for use in the analysis of the effluent samples. Alternative 40 CFR 136 approved methods may be used provided the LOQ is less than the monthly average and/or daily maximum effluent limitations.

The permittee may determine a case-specific Method Detection Level (MDL) using one of the analytical methods specified below, or any other test method which is approved by IDEM prior to use. The MDL shall be derived by the procedure specified for MDLs contained in 40 CFR Part 136, Appendix B, and the limit of quantitation shall be set equal to 3.18 times the MDL. **NOTE:** The MDL for purposes of this document, is synonymous with the "limit of detection" or "LOD" as defined in 327 IAC 5-1.5-26: "the minimum concentration of a substance that can

be measured and reported with ninety-nine percent (99%) confidence that the analyte concentration is greater than zero (0) for a particular analytical method and sample matrix".

Parameter	EPA Method	LOD	LOQ
Cadmium	3113 B	0.1 µg/l	0.32 µg/l
Chromium	3111 C or 3113 B	2.0 µg/l	6.4 µg/l
Copper	3113 B	1.0 µg/l	3.2 µg/l
Cyanide, Available*	OIA-1677-09 (available)	0.5 µg/l	1.6 µg/l
Cyanide, Available*	Kelada-01 (available)	0.5 µg/l	1.6 µg/l
Lead	3113 B	1.0 µg/l	3.2 µg/l
Mercury	1631, Revision E	0.2 ng/l	0.5 ng/l
Nickel	3113 B	1.0 µg/l	3.2 µg/l
Selenium	200.9, Rev. 2.2 (1994)	0.6 µg/l	1.9 µg/l
Silver	3113 B	0.2 µg/l	0.64 µg/l
Zinc	200.7, Revision 4.4 or 3120 B	2.0 µg/l	6.4 µg/l

\*Free cyanide shall be reported as free cyanide but measured using one of the approved EPA test methods above for available cyanide.

- [2] Refer to the Schedule of Compliance in Part I.E. of this permit.
- [3] Mercury monitoring shall be conducted six times annually (i.e. every other month) for the term of the permit. Monitoring shall be conducted and reported in the months of February, April, June, August, October, and December of each year. Mercury monitoring and analysis will be performed using EPA Test Method 1631, Revision E. If Method 1631, Revision E is further revised during the term of this permit, the permittee and/or its contract laboratory is required to utilize the most current version of the method immediately after approval by EPA.
- [4] The permittee applied for, and received, a variance from the water quality criterion used to establish the referenced mercury WQBELs under the streamlined mercury variance (SMV) procedures of 327 IAC 5-3.5. Compliance with the interim discharge limit will demonstrate compliance with this permit.
- [5] For the term of the NPDES permit, the permittee is subject to the interim discharge limit developed under the provisions of 327 IAC 5-3.5-8. Each reporting period (i.e., bi-monthly), the permittee shall report both a daily value and an annual average value for mercury. The annual average discharge value is to be calculated as the average of the measured effluent daily values for mercury over the most recent (rolling) twelve-month period. Compliance with the interim discharge limit will be achieved when the annual average discharge value for the most recent twelve-month period is less than the interim discharge limit.
- [6] Annual average for the purpose of the mercury interim discharge limit.

4. Additional Monitoring Requirements

Beginning on the effective date of this permit, the permittee shall conduct the following monitoring activities:

a. Influent Monitoring

In addition to the requirements contained in Part I.B.2 of the NPDES permit, the permittee shall monitor the influent to its wastewater treatment facility for the following pollutants. Samples shall be representative of the raw influent in accordance with 327 IAC 5-2-13(b).

TABLE 5

Parameter	Quality or Concentration			Monitoring Requirements	
	Monthly Average	Daily Maximum	Units	Measurement Frequency	Sample Type
Cadmium [1]	-----	Report	mg/l	1 X Quarterly	24 Hr. Comp.
Chromium [1]	-----	Report	mg/l	1 X Quarterly	24 Hr. Comp.
Copper [1]	Report	Report	mg/l	2 X Monthly	24 Hr. Comp.
Cyanide [1]	-----	Report	mg/l	1 X Quarterly	Grab
Lead [1]	-----	Report	mg/l	1 X Quarterly	24 Hr. Comp.
Mercury [1][2]	----	Report	ng/l	6 X Annually	Grab
Nickel [1]	-----	Report	mg/l	1 X Quarterly	24 Hr. Comp.
Selenium [1]	Report	Report	mg/l	2 X Monthly	24 Hr. Comp.
Silver [1]	Report	Report	mg/l	2 X Monthly	24 Hr. Comp.
Zinc [1]	-----	Report	mg/l	1 X Quarterly	24 Hr. Comp.

NOTE: For measurement frequencies less than once per month, the permittee shall report the result from the monitoring period on the Discharge Monitoring Report (DMR) for the final month of the reporting timeframe, beginning with January of each year. For example, for quarterly monitoring, the permittee may conduct sampling within the month of January, February or March. The result from this reporting timeframe shall be reported on the March DMR, regardless of which of the months within the quarter the sample was taken.

[1] The permittee shall measure and report this parameter as Total Recoverable Metal. Cyanide, if monitored, shall be reported as Free Cyanide.

[2] Mercury monitoring shall be conducted six times annually (i.e. every other month) for the term of the permit. Monitoring shall be conducted and reported in the months of February, April, June, August, October, and December of each year. Mercury monitoring and analysis will be performed using EPA Test Method 1631, Revision E. If Method 1631, Revision E is further revised during the term of this permit, the permittee

and/or its contract laboratory is required to utilize the most current version of the method immediately after approval by EPA.

b. Priority Pollutants Monitoring

The permittee shall conduct an annual inventory of priority pollutants (see 40 CFR 423, Appendix A) and shall identify and quantify additional organic compounds which occur in the influent, effluent, and sludge. The analytical report shall be sent to the Pretreatment Group. This report is due in December of each year. The inventory shall consist of:

(1) Sampling and Analysis of Influent and Effluent

Sampling shall be conducted on a day when industrial discharges are occurring at normal or maximum levels. The samples shall be 24-hour flow proportional composites, except for cyanide and volatile organics, which shall be taken by appropriate grab sampling techniques. Analysis for the

U.S. EPA organic priority pollutants shall be performed using U.S. EPA methods 624, 625 and 608 in 40 CFR 136, or other equivalent methods approved by U.S. EPA. Equivalent methods must be at least as sensitive and specific as methods 624, 625 and 608.

All samples must be collected, preserved and stored in accordance with 40 CFR 136, Appendix A. Samples for volatile organics must be analyzed within 14 days of collection. Samples for semivolatile organics, PCBs and pesticides must be extracted within 7 days of collection and analyzed within 40 days of extraction. For composite samples, the collection date shall be the date at the end of the daily collection period.

(2) Sampling and Analysis of Sludge

Sampling collection, storage, and analysis shall conform to the U.S. EPA recommended procedures equivalent to methods in accordance with 40 CFR 503. Special sampling and/or preservation techniques will be required for those pollutants which deteriorate rapidly.

Sludge samples for volatile organics must be analyzed within 14 days of collection. Sludge samples for semivolatile organics, PCBs and pesticides must be extracted within 14 days of collection and analyzed within 40 days of extraction.

(3) Additional Pollutant Identification

In addition to the priority organic pollutants, a reasonable attempt shall be made to identify and quantify the ten most abundant constituents of each fraction (excluding priority pollutants and unsubstituted aliphatic

compounds) shown to be present by peaks on the total ion plots (reconstructed gas chromatograms) more than ten times higher than the adjacent background noise. Identification shall be attempted through the use of U.S. EPA/NIH computerized library of mass spectra, with visual confirmation by an experienced analyst. Quantification may be based on an order of magnitude estimate based upon comparison with an internal standard.

The priority pollutant report should identify the additional steps necessary to determine whether the pollutants that are present interfere, pass through, or otherwise violate 40 CFR 403.2. Upon such determination, the report must also identify the steps taken to develop and enforce local limitations on industrial discharges for those pollutants. This is a requirement of 40 CFR 403.5.

## B. MONITORING AND REPORTING

### 1. Representative Sampling

Samples and measurements taken as required herein shall be representative of the volume and nature of the monitored discharge flow and shall be taken at times which reflect the full range and concentration of effluent parameters normally expected to be present. Samples shall not be taken at times to avoid showing elevated levels of any parameters.

### 2. Data on Plant Operation

The raw influent and the wastewater from intermediate unit treatment processes, as well as the final effluent shall be sampled and analyzed for the pollutants and operational parameters specified by the applicable Monthly Report of Operation Form, as appropriate, in accordance with 327 IAC 5-2-13. Except where the permit specifically states otherwise, the sample frequency for the raw influent and intermediate unit treatment process shall be at a minimum the same frequency as that for the final effluent. The measurement frequencies specified in each of the tables in Part I.A. are the minimum frequencies required by this permit.

### 3. Reporting per Monitoring Period

The permittee shall submit accurate monitoring reports to the Indiana Department of Environmental Management containing results obtained during each monitoring period and shall be submitted no later than the 28th day of the month following each completed monitoring period. Each monitoring period report shall be submitted no less than annually and no more than monthly, as per parameter measurement frequency listed. These reports shall include, but not necessarily be limited to, the Discharge Monitoring Report (DMR) and the Monthly Report of Operation (MRO).

Permittees with metals monitoring requirements shall complete and submit the Indiana MRO Form (State Form 10829 MRO for the Activated Sludge Type WWTP – expanded version) to report their influent and/or effluent data for metals and other toxics.] [Permittees with combined sewer overflow discharges must also submit the CSO Monthly Report of Operation to IDEM by the 28<sup>th</sup> day of the month following each completed monitoring period.

All reports shall be submitted electronically by using the NetDMR application, upon registration, receipt of the NetDMR Subscriber Agreement, and IDEM approval of the proposed NetDMR Signatory. Access the NetDMR website (for initial registration and DMR/MMR submittal) via CDX at: <https://cdx.epa.gov/>. The Regional Administrator may request the permittee to submit monitoring reports to the Environmental Protection Agency if it is deemed necessary to assure compliance with the permit.

A calendar week will begin on Sunday and end on Saturday. Partial weeks consisting of four or more days at the end of any month will include the remaining days of the week, which occur in the following month in order to calculate a consecutive seven-day average. This value will be reported as a weekly average or seven-day average on the MRO for the month containing the partial week of four or more days. Partial calendar weeks consisting of less than four days at the end of any month will be carried forward to the succeeding month and reported as a weekly average or a seven-day average for the calendar week that ends with the first Saturday of that month.

#### 4. Definitions

##### a. Calculation of Averages

Pursuant to 327 IAC 5-2-11(a)(5), the calculation of the average of discharge data shall be determined as follows: For all parameters except fecal coliform and *E. coli*, calculations that require averaging of sample analyses or measurements of daily discharges shall use an arithmetic mean unless otherwise specified in this permit. For fecal coliform, the monthly average discharge and weekly average discharge, as concentrations, shall be calculated as a geometric mean. For *E. coli*, the monthly average discharge, as a concentration, shall be calculated as a geometric mean.

##### b. Terms

(1) “Monthly Average” -The monthly average discharge means the total mass or flow-weighted concentration of all daily discharges during a calendar month on which daily discharges are sampled or measured, divided by the number of daily discharges sampled and/or measured during such calendar month. The monthly average discharge limitation is the highest allowable average monthly discharge for any calendar month.

(2) "Weekly Average" - The weekly average discharge means the total mass or flow weighted concentration of all daily discharges during any calendar week for which daily discharges are sampled or measured, divided by the number of daily discharges sampled and/or measured during such

calendar week. The average weekly discharge limitation is the maximum allowable average weekly discharge for any calendar week.

(3) "Daily Maximum" - The daily maximum discharge limitation is the maximum allowable daily discharge for any calendar day. The "daily discharge" means the total mass of a pollutant discharged during the calendar day or, in the case of a pollutant limited in terms other than mass pursuant to 327 IAC 5-2-11(e), the average concentration or other measurement of the pollutant specified over the calendar day or any twenty-four hour period that represents the calendar day for purposes of sampling.

(4) "24-hour Composite" - A 24-hour composite sample consists of at least four (4) individual flow-proportioned samples of wastewater, taken by the grab sample method over equal time intervals during the period of operator attendance or by an automatic sampler, and which are combined prior to analysis. A flow proportioned composite sample shall be obtained by:

(a) recording the discharge flow rate at the time each individual sample is taken,

(b) adding together the discharge flow rates recorded from each individual sampling time to formulate the "total flow value,"

(c) dividing the discharge flow rate of each individual sampling time by the total flow value to determine its percentage of the total flow value, and

(d) multiplying the volume of the total composite sample by each individual sample's percentage to determine the volume of that individual sample which will be included in the total composite sample.

Alternatively, a 24-hour composite sample may be obtained by an automatic sampler on an equal time interval basis over a twenty-four hour period provided that a minimum of 24 samples are taken and combined prior to analysis. The samples do not need to be flow-proportioned if the permittee collects samples in this manner.

(5) CBOD<sub>5</sub>: Five-day Carbonaceous Biochemical Oxygen Demand

(6) TSS: Total Suspended Solids

(7) *E. coli*: *Escherichia coli* bacteria

- (8) The “Regional Administrator” is defined as the Region V Administrator, U.S. EPA, located at 77 West Jackson Boulevard, Chicago, Illinois 60604.
- (9) The “Commissioner” is defined as the Commissioner of the Indiana Department of Environmental Management, located at the following address: 100 North Senate Avenue, Indianapolis, Indiana 46204-2251.
- (10) Limit of Detection or LOD is defined as a measurement of the concentration of a substance that can be measured and reported with 99% confidence that the analyte concentration is greater than zero (0) for a particular analytical method and sample matrix. The LOD is equivalent to the Method Detection Level or MDL.
- (11) Limit of Quantitation or LOQ is defined as a measurement of the concentration of a contaminant obtained by using a specified laboratory procedure calibrated at a specified concentration above the method detection level. It is considered the lowest concentration at which a particular contaminant can be quantitatively measured using a specified laboratory procedure for monitoring of the contaminant. This term is also called the limit of quantification or quantification level.
- (12) Method Detection Level or MDL is defined as the minimum concentration of an analyte (substance) that can be measured and reported with a ninety-nine percent (99%) confidence that the analyte concentration is greater than zero (0) as determined by the procedure set forth in 40 CFR Part 136, Appendix B. The method detection level or MDL is equivalent to the LOD.

## 5. Test Procedures

The analytical and sampling methods used shall conform to the version of 40 CFR 136 incorporated by reference in 327 IAC 5. Different but equivalent methods are allowable if they receive the prior written approval of the Commissioner and the U.S. Environmental Protection Agency. When more than one test procedure is approved for the purposes of the NPDES program under 40 CFR 136 for the analysis of a pollutant or pollutant parameter, the test procedure must be sufficiently sensitive as defined at 40 CFR 122.21(e)(3) and 122.44(i)(1)(iv).

## 6. Recording Results

For each measurement or sample taken pursuant to the requirements of this permit, the permittee shall record and maintain records of all monitoring information on activities under this permit, including the following information:

- a. The exact place, date, and time of sampling or measurements;
- b. The person(s) who performed the sampling or measurements;

- c. The dates and times the analyses were performed;
- d. The person(s) who performed the analyses;
- e. The analytical techniques or methods used; and
- f. The results of all required analyses and measurements.

7. Additional Monitoring by Permittee

If the permittee monitors any pollutant at the location(s) designated herein more frequently than required by this permit, using approved analytical methods as specified above, the results of such monitoring shall be included in the calculation and reporting of the values required in the Monthly Discharge Monitoring Report and on the Monthly Report of Operation form. Such increased frequency shall also be indicated on these forms. Any such additional monitoring data which indicates a violation of a permit limitation shall be followed up by the permittee, whenever feasible, with a monitoring sample obtained and analyzed pursuant to approved analytical methods. The results of the follow-up sample shall be reported to the Commissioner in the Monthly Discharge Monitoring Report.

8. Records Retention

All records and information resulting from the monitoring activities required by this permit, including all records of analyses performed and calibration and maintenance of instrumentation and recording from continuous monitoring instrumentation, shall be retained for a minimum of three (3) years. In cases where the original records are kept at another location, a copy of all such records shall be kept at the permitted facility. The three-year period shall be extended:

- a. automatically during the course of any unresolved litigation regarding the discharge of pollutants by the permittee or regarding promulgated effluent guidelines applicable to the permittee; or
- b. as requested by the Regional Administrator or the Indiana Department of Environmental Management.

C. REOPENING CLAUSES

In addition to the reopening clause provisions cited at 327 IAC 5-2-16, the following reopening clauses are incorporated into this permit:

- 1. This permit may be modified or, alternately, revoked and reissued after public notice and opportunity for hearing to incorporate effluent limitations reflecting the results of a Wasteload allocation if the Department of Environmental Management determines that such effluent limitations are needed to assure that State Water Quality Standards are met in the receiving stream.

2. This permit may be modified due to a change in sludge disposal standards pursuant to Section 405(d) of the Clean Water Act, if the standards when promulgated contain different conditions, are otherwise more stringent, or control pollutants not addressed by this permit.
3. This permit may be modified, or, alternately, revoked and reissued, to comply with any applicable effluent limitation or standard issued or approved under section 301(b)(2)(C), (D) and (E), 304(b)(2), and 307(a)(2) of the Clean Water Act, if the effluent limitation or standard so issued or approved:
  - a. contains different conditions or is otherwise more stringent than any effluent limitation in the permit; or
  - b. controls any pollutant not limited in the permit.
4. This permit may be modified or, alternatively, revoked and reissued after public notice and opportunity for hearing to incorporate monitoring requirements and effluent limitations for cadmium, chromium, cyanide, lead, nickel, and zinc if the Department of Environmental Management determines that such monitoring requirements and effluent limitations are needed to assure that State Water Quality standards are met in the receiving streams.
5. This permit may be modified, or alternately, revoked and reissued, after public notice and opportunity for hearing, to include a case-specific Method Detection Level (MDL). The permittee must demonstrate that such action is warranted in accordance with the procedure specified under Appendix B, 40 CFR Part 136, or approved by the Indiana Department of Environmental Management.
6. This permit may be modified or, alternatively, revoked and reissued after public notice and opportunity for hearing to incorporate additional requirements or limitations for specific toxicants if the required additional analyses in Part I.A. indicate that such additional requirements and/or limitations are necessary to assure that State Water Quality Standards are met in the receiving stream.
7. This permit may be modified, or, alternately, revoked and reissued, after public notice and opportunity for hearing to:
  - a. reduce the mercury monitoring frequency, if a minimum of 12 months (six (6) consecutive samples) of monitoring data indicates that there is not a reasonable potential for mercury to exceed water quality standards, or
  - a. include effluent limitations for mercury, if the mercury is found to be discharged at a level that will cause, have the reasonable potential to cause, or contribute to an excursion above a water quality criteria.

## D. WHOLE EFFLUENT TOXICITY TESTING REQUIREMENTS

To adequately assess the effects of the effluent on aquatic life, the permittee is required by this section of the permit to conduct chronic Whole Effluent Toxicity (WET) testing. Part I.D.1. of this permit describes the testing procedures and Part I.D.2. describes the Toxicity Reduction Evaluation (TRE) which is only required if the effluent demonstrates toxicity in two (2) consecutive toxicity tests as described in Part I.D.1.g.

### 1. Whole Effluent Toxicity (WET) Tests

The permittee must conduct the series of aquatic toxicity tests described below using freshwater aquatic organisms as the test species to monitor the acute and chronic toxicity of the effluent discharged from Outfall 001.

If toxicity is demonstrated in two (2) consecutive toxicity tests as described in Part I.D.1.g. with any test species during the term of the permit, the permittee is required to conduct a TRE under Part I.D.2.

#### a. Toxicity Test Procedures and Data Analysis

- (1) All test organisms, test procedures, and quality assurance criteria used must be in accordance with the Short-term Methods for Estimating the Chronic Toxicity of Effluents and Receiving Water to Freshwater Organisms, Fourth Edition, Section 11, Fathead Minnow (*Pimephales promelas*) Larval Survival and Growth Test Method 1000.0, and Section 13, Daphnid (*Ceriodaphnia dubia*) Survival and Reproduction Test Method 1002.0, EPA 821-R-02-013, October 2002 (hereinafter "Chronic Toxicity Test Method"), or most recent update that conforms to the version of 40 CFR 136 incorporated by reference in 327 IAC 5. References to specific portions of the Chronic Toxicity Test Method contained in this Part I.D. are provided for informational purposes. If the Chronic Toxicity Test Method is updated, the corresponding provisions of that updated method would be applicable.
- (2) Any circumstances not covered by the above methods, or that require deviation from the specified methods must first be approved by the IDEM Office of Water Quality, Municipal NPDES Permits Section.
- (3) The determination of acute and chronic endpoints of toxicity (LC<sub>50</sub>), NOEC, and IC<sub>25</sub> values) must be made in accordance with the procedures in Section 9, "Chronic Toxicity Test Endpoints and Data Analysis" and the Data Analysis procedures as outlined in Section 11 for Fathead Minnow (Test Method 1000.0; see flowcharts in Figures 5, 6, and 9) and Section 13 for *Ceriodaphnia dubia* (Test Method 1002.0; see flowcharts in Figures 4

and 6) of the Chronic Toxicity Test Method. The IC<sub>25</sub> value together with 95% confidence intervals calculated by the Linear Interpolation and Bootstrap Methods in Appendix M of the Chronic Toxicity Test Method must be determined in addition to the NOEC value.

b. Types of Whole Effluent Toxicity Tests

- (1) The permittee must conduct a 3-brood (7-day) definitive static-renewal daphnid (*Ceriodaphnia dubia*) survival and reproduction toxicity test and a 7-day definitive static-renewal Fathead Minnow (*Pimephales promelas*) larval survival and growth toxicity test.
- (2) All tests must be conducted using 24-hour composite samples of final effluent. For each test, three effluent samples are to be collected on alternate days (e.g. collected on days one, three, and five). The first effluent sample will be used for test initiation and for test solution renewal on day 2. The second effluent sample will be used for test solution renewal on days 3 and 4. The third effluent sample will be used for test solution renewal on days 5, 6, and 7. If shipping problems are encountered with the second effluent sample after a test has been initiated, the test must be repeated. However, if shipping problems are encountered with the third effluent sample, the second effluent sample may continue to be used for test renewal on day 5. The third effluent sample will then be used for test solution renewal on days 6 and 7.
- (3) The whole effluent dilution series for the definitive test must include a control and at least five effluent concentrations with a minimum dilution factor of 0.5. The effluent concentrations selected must include and, if practicable, bracket the effluent concentrations associated with the determinations of acute and chronic toxicity provided in Part I.D.1.f. Guidance on selecting effluent test concentrations is included in Section 8.10 of the Chronic Toxicity Test Method. The use of an alternate procedure for selecting test concentrations must first be approved by the IDEM Office of Water Quality, Municipal NPDES Permits Section.
- (4) If, in any control, more than 10% of the test organisms die in the first 48 hours with a daphnid species or the first 96 hours with a Fathead Minnow, or more than 20% of the test organisms in 7 days, that test is considered invalid, and the toxicity tests must be repeated. In addition, if in the *Ceriodaphnia dubia* survival and reproduction test, the average number of young produced per surviving female in the control group is less than 15, or if 60% of surviving control females have less than three broods; and in the Fathead Minnow (*Pimephales promelas*) survival and growth test, if the mean dry weight of surviving fish in the control group is less than 0.25 mg,

that test is considered invalid and must also be repeated. All other test conditions and test acceptability criteria for the Fathead Minnow (*Pimephales promelas*) and *Ceriodaphnia dubia* chronic toxicity tests must be in accordance with the test requirements in Section 11 (Test Method 1000.0), Table 1 and Section 13 (Test Method 1002.0), Table 3, respectively, of the Chronic Toxicity Test Method.

c. Effluent Sample Collection and Chemical Analysis

- (1) Whole effluent samples taken for the purposes of toxicity testing must be 24-hour composite samples collected at a point that is representative of the final effluent, but prior to discharge. Effluent sampling for the toxicity testing may be coordinated with other permit sampling requirements as appropriate to avoid duplication. First use of the whole effluent toxicity testing samples must not exceed 36 hours after termination of the 24-hour composite sample collection and must not be used for longer than 72 hours after first use.
- (2) Chemical analysis must coincide with, and if test methods allow, be conducted on each effluent sample taken for toxicity testing, including each sample taken for the repeat testing as outlined in Part I.D.1.f.3. The chemical analysis detailed in Part I.A.1. and Part I.A.3 must be conducted for the effluent sample in accordance with Part I.B.5. of this permit. The results from these chemical analyses must be included with the full Whole Effluent Toxicity (WET) test laboratory report submitted pursuant to Part I.D.1.e.(3).

d. Toxicity Testing Frequency and duration

The toxicity tests specified in Part I.D.1.b. must be conducted once **every six (6) months**, as calculated from the effective date of the permit, for the duration of the permit.

If a TRE is initiated during the term of the permit, after receiving notification under Part I.D.1.e., the Compliance Data Section will suspend the toxicity testing requirements above for the term of the TRE schedule described in Part I.D.2. After successful completion of the TRE, the toxicity tests specified in Part I.D.1.b must be conducted once **every six (6) months**, as calculated from the first day of the first month following successful completion of the post-TRE toxicity tests (see Part I.D.2.c(4)) for the remainder of the permit term.

e. Reporting

- (1) Notifications of the failure of two (2) consecutive toxicity tests and the intent to begin the implementation of a TRE under Part I.D.1.g. must be submitted in writing to the IDEM Office of Water Quality, Compliance Data Section.
- (2) Results of all toxicity tests, including invalid tests, must be reported to IDEM according to the general format and content recommended in the Chronic Toxicity Test Method, Section 10, "Report Preparation and Test Review". However, only the results of valid toxicity tests are to be reported on the discharge monitoring report (DMR). The results of the toxicity tests and laboratory report are due by the earlier of 60 days after completion of the test or the 28<sup>th</sup> day of the month following the end of the testing period established in Part I.D.1.d.
- (3) The full WET test laboratory report must be submitted electronically as an attachment to an e-mail to the IDEM Office of Water Quality, Compliance Data Section at [wwreports@idem.IN.gov](mailto:wwreports@idem.IN.gov). The results must also be submitted via NetDMR.
- (4) For quality control and ongoing laboratory performance, the laboratory report must include results from appropriate standard reference toxicant tests. This will consist of acute (LC<sub>50</sub> values), if applicable and chronic (NOEC, LOEC, and IC<sub>25</sub> values) endpoints of toxicity obtained from reference toxicant tests conducted within 30 days of the most current effluent toxicity tests and from similarly obtained historical reference toxicant data with mean values and appropriate ranges for each species tested for at least three months to one year. Toxicity test reports must also include copies of chain-of-custody records and laboratory raw data sheets.
- (5) Statistical procedures used to analyze and interpret toxicity data (e.g. Fisher's Exact Test and Steel's Many-one Rank Test for 7-day survival of test organisms; tests of normality (e.g., Shapiro Wilk's Test) and homogeneity of variance (e.g., Bartlett's Test); appropriate parametric (e.g. Dunnett's Test) and non-parametric (e.g. Steel's Many-one Rank Test) significance tests and point estimates (IC<sub>25</sub>) of effluent toxicity, etc.; together with graphical presentation of survival, growth, and reproduction of test organisms), including critical values, levels of significance, and 95% confidence intervals must be described and included as part of the toxicity test laboratory report.
- (6) For valid toxicity tests, the WET test laboratory report must include a summary table of the results for each species tested, as shown in the table presented below. This table will provide toxicity test results, reported in

acute toxic units (TU<sub>a</sub>) and chronic toxic units (TU<sub>c</sub>) for evaluation under Part I.D.1.f. and reporting on the DMR.

Test Organism [1]	Test Type	Endpoint [2]	Units	Result	Compliance Limit [6]	Pass/Fail [7]	Reporting
<i>Ceriodaphnia dubia</i>	3-brood (7-day) Definitive Static-Renewal Survival and Reproduction	48-hr. LC <sub>50</sub>	%	Report			Laboratory Report
			TU <sub>a</sub>	Report			
		NOEC Survival	%	Report			
			TU <sub>c</sub>	Report			
		NOEC Reproduction	%	Report			
			TU <sub>c</sub>	Report			
		IC <sub>25</sub> Reproduction	%	Report			
			TU <sub>c</sub>	Report			
Toxicity (acute) [3]	TU <sub>a</sub>	Report [5]	1.0	Report	Laboratory Report and <b>NetDMR</b> (Parameter Code 61425)		
Toxicity (chronic) [4]	TU <sub>c</sub>	Report [5]	3.8	Report	Laboratory Report and <b>NetDMR</b> (Parameter Code 61426)		
<i>Pimephales promelas</i>	7-day Definitive Static-Renewal Larval Survival and Growth	96-hr. LC <sub>50</sub>	%	Report			Laboratory Report
			TU <sub>a</sub>	Report			
		NOEC Survival	%	Report			
			TU <sub>c</sub>	Report			
		NOEC Growth	%	Report			
			TU <sub>c</sub>	Report			
		IC <sub>25</sub> Growth	%	Report			
			TU <sub>c</sub>	Report			
Toxicity (acute) [3]	TU <sub>a</sub>	Report [5]	1.0	Report	Laboratory Report and <b>NetDMR</b> (Parameter Code 61427)		
Toxicity (chronic) [4]	TU <sub>c</sub>	Report [5]	3.8	Report	Laboratory Report and <b>NetDMR</b> (Parameter Code 61428)		

- [1] For the WET test laboratory report, eliminate from the table any species that was not tested.
- [2] A separate acute test is not required. The endpoint of acute toxicity must be extrapolated from the chronic toxicity test.
- [3] The toxicity (acute) endpoint for *Ceriodaphnia dubia* is the 48-hr. LC<sub>50</sub> results reported in acute toxic units (TU<sub>a</sub>). The toxicity (acute) endpoint for *Pimephales promelas* is the 96-hr. LC<sub>50</sub> result reported in acute toxic units (TU<sub>a</sub>).
- [4] The toxicity (chronic) endpoint for *Ceriodaphnia dubia* is the higher of the NOEC Survival, NOEC Reproduction, and IC<sub>25</sub> Reproduction values reported in chronic toxic units (TU<sub>c</sub>).
- [5] Report the values for acute and chronic endpoints of toxicity determined in [3] and [4] for the corresponding species. These values are the ones that need to be reported on the DMR.
- [6] An exceedance of any of these values results in a demonstration of toxicity that requires the permittee to take the actions set forth in either Part I.D.1.f or Part I.D.1.g., as applicable.
- [7] If the toxicity result (in TU<sub>s</sub>) is less than or equal to the compliance limit, report "Pass". If the toxicity result (in TU<sub>s</sub>) exceeds the compliance limit, report "Fail".

f. Demonstration of Toxicity

- (1) Toxicity (acute) will be demonstrated if the effluent is observed to have exceeded **1.0 TU<sub>a</sub>** (acute toxic units) for *Ceriodaphnia dubia* in 48 hours or in 96 hours for *Pimephales promelas*. For this purpose, a separate acute toxicity test is not required. The results for the acute toxicity demonstration must be extrapolated from the chronic toxicity test. For the purpose of selecting test concentrations under Part I.D.1.b.(3), the effluent concentration associated with acute toxicity is 100%.
- (2) Toxicity (chronic) will be demonstrated if the effluent is observed to have exceeded **3.8 TU<sub>c</sub>** (chronic toxic units) for *Ceriodaphnia* or *Pimephales promelas* from the chronic toxicity test. For the purpose of selecting test concentrations under Part I.D.1.b.(3), the effluent concentration associated with chronic toxicity is **26.3%**.
- (3) If toxicity (acute) or toxicity (chronic) is demonstrated in any of the chronic toxicity tests specified at (1) or (2) above, a repeat chronic toxicity test using the procedures in Part I.D.1. of this permit and the same test species

must be initiated within two (2) weeks of test failure, or as soon thereafter as practicable. During the sampling for any repeat tests, the permittee must also collect and preserve sufficient effluent samples for use in any Toxicity Identification Evaluation (TIE) and/or TRE, if necessary.

g. Requirement to Conduct a Toxicity Reduction Evaluation

If any two (2) consecutive chronic toxicity tests, including any and all repeat tests, demonstrate acute or chronic toxicity for the same or the other test species under Part I.D.1.f., the permittee must notify the IDEM Office of Water Quality, Compliance Data Section under Part I.D.1.e. within 30 days of the termination of the second test, and begin the implementation of TRE as described in Part I.D.2. After receiving notification from the permittee, the Compliance Data Section will suspend the whole effluent toxicity testing requirements in Part I.D.1. for the term of the TRE schedule.

h. Definitions

- (1) "Acute toxic unit" or "TU<sub>a</sub>" is defined as  $100/LC_{50}$  where the  $LC_{50}$  is expressed as a percent effluent in the test medium of an acute whole effluent toxicity (WET) test that is statistically or graphically estimated to be lethal to fifty percent (50%) of the test organism.
- (2) "Chronic toxic unit" or "TU<sub>c</sub>" is defined as  $100/NOEC$  or  $100/IC_{25}$ , where the NOEC or  $IC_{25}$  are expressed as a percent effluent in the test medium.
- (3) "Inhibition concentration 25" or "IC<sub>25</sub>" means the toxicant (effluent) concentration that would cause a twenty-five percent (25%) reduction in a nonquantal biological measurement for the test population. For example, the  $IC_{25}$  is the concentration of toxicant (effluent) that would cause a twenty-five percent (25%) reduction in mean young per female or in growth for the test population.
- (4) "No observed effect concentration" or "NOEC" is the highest concentration of toxicant (effluent) to which organisms are exposed in a full life cycle or partial life cycle (short term) test, that causes no observable adverse effects on the test organisms, that is, the highest concentration of toxicant (effluent) in which the values for the observed responses are not statistically significantly different from the controls.

2. Toxicity Reduction Evaluation (TRE) Schedule

The development and implementation of a TRE is only required if toxicity is demonstrated in two (2) consecutive tests as described in Part I.D.1.g. The post-

TRE toxicity testing requirements in Part I.D.2.c. must also be completed as part of the TRE schedule.

Milestone Dates: See a. through e. below for more detail on the TRE milestone dates.

<b>Requirement</b>	<b>Deadline</b>
Development and Submittal of a TRE Plan	Within 90 days of the date of two (2) consecutive failed toxicity tests (i.e., the date of termination of the second test).
Initiate a TRE Study	Within 30 days of TRE Plan submittal
Submit TRE Progress Reports	Every 90 days beginning six (6) months from the date of two (2) consecutive failed toxicity tests (i.e., the date of termination of the second test).
Post-TRE Toxicity Testing Requirements	Immediately upon completion of the TRE, conduct three (3) consecutive months of toxicity tests with both test species; if no acute or chronic toxicity is shown with any test species, reduce toxicity tests to once <b>every six (6) months</b> for the remainder of the permit term. If post-TRE toxicity testing demonstrates toxicity, continue the TRE study.
Submit Final TRE Report	Within 90 days of successfully completing the TRE (including the post-TRE toxicity testing requirements), not to exceed three (3) years from the date that toxicity is initially demonstrated in two (2) consecutive toxicity tests (i.e., the date of termination of the second test).

a. Development of TRE Plan

Within 90 days of the date of two (2) consecutive failed toxicity tests (i.e. the date of termination of the second test), the permittee must submit plans for an effluent TRE to the IDEM Office of Water Quality, Compliance Data Section. The TRE plan must include appropriate measures to reduce toxicity in the effluent discharge to levels that demonstrate no toxicity with any test species as described in Part I.D.1.f. Guidance on conducting effluent toxicity reduction evaluations, including Toxicity Identification Evaluations (TIEs) to characterize and identify the causative toxicants, if necessary, is available from EPA and from the EPA publications listed below:

(1) Method for Aquatic Toxicity Identification Evaluations:

Phase I Toxicity Characterization Procedures, Second Edition (EPA/600/6-91/003), February 1991.

Phase II Toxicity Identification Procedures for Samples Exhibiting Acute and Chronic Toxicity (EPA/600/R-92/080), September 1993.

Phase III Toxicity Confirmation Procedures for Samples Exhibiting Acute and Chronic Toxicity (EPA/600/R-92/081), September 1993.

(2) Toxicity Identification Evaluation: Characterization of chronically Toxic Effluents, Phase I (EPA/600/6-91/005F), May 1992.

(3) Toxicity Reduction evaluation Guidance for Municipal Wastewater Treatment Plants (EPA/833B-99-002), August 1999.

(4) Clarifications Regarding Toxicity Reduction and Identification Evaluations in the National Pollutant Discharge Elimination System Program, U.S. EPA, March 27, 2001.

b. Conduct the TRE

Within 30 days after submittal of the TRE plan to the Compliance Data Section, the permittee must initiate the TRE consistent with the TRE plan.

c. Post-TRE Toxicity Testing Requirements

(1) After completing the TRE, the permittee must conduct monthly post-TRE toxicity tests with the two (2) test species *Ceriodaphnia dubia* and Fathead Minnow (*Pimephales promelas*) for a period of three (3) consecutive months.

(2) If the three (3) monthly tests demonstrate no toxicity with any test species as described in Part I.D.1.f.(1) and f. (2), the TRE will be considered successful. Otherwise, the TRE study must be continued.

(3) The post-TRE toxicity tests must be conducted in accordance with the procedures in Part I.D.1. The results of these tests must be submitted as part of the final TRE Report required under Part I.D.2.d.

(4) After successful completion of the TRE, the permittee must resume the chronic toxicity tests required in Part I.D.1. The established starting date

for the frequency in Part I.D.1.d. is the first day of the first month following successful completion of the post-TRE toxicity tests.

d. Reporting

- (1) Progress reports must be submitted every 90 days to the IDEM Office of Water Quality, Compliance Data Section beginning six (6) months from the date of two (2) consecutive failed toxicity tests (i.e., the date of termination of the second test). Each TRE progress report must include a listing of proposed activities for the next quarter and a schedule to reduce toxicity in the effluent discharge to acceptable levels through control of the toxicant source or treatment of whole effluent.
- (2) Within 90 days of successfully completing the TRE, including the three (3) consecutive monthly tests required as part of the post-TRE toxicity testing requirements under Part I.D.2.c., the permittee must submit to the IDEM Office of Water Quality, Compliance Data Section a final TRE Report that includes a discussion of the TRE results, along with the starting date established under Part I.D.2.c.(4). for the continuation of the toxicity testing required in Part I.D.1.

e. Compliance Date

The permittee must complete items a., b., c., and d. from Part I.D.2. and reduce toxicity in the effluent discharge to acceptable levels as soon as possible, but no later than three (3) years from the date that toxicity is initially demonstrated in two (2) consecutive toxicity tests (i.e. the date of termination of the second test) as described in Part I.D.1.g.

E. SCHEDULE OF COMPLIANCE

1. The permittee shall submit a written progress report to the Compliance Data Section, Office of Water Quality (OWQ) six (6) months from the effective date of the permit. The progress report shall include, among other items, a description of the method(s) selected for meeting the final requirements for copper, selenium, and silver. The final effluent limitations for copper, selenium, silver are deferred for the term of this compliance schedule, unless the final effluent limitations can be met at an earlier date. The permittee shall notify the Compliance Data Section of OWQ as soon as the final effluent limitations for copper, selenium, and silver can be met. Upon receipt of such notification by OWQ, the final limitations for copper, selenium, and silver will become effective, but no later than thirty-six (36) months from the effective date of this permit. Monitoring and reporting of effluent copper, selenium, and silver is required during the interim period.

2. If construction is required, a construction permit application (including Plans and Specifications) for complying with final requirements shall be submitted (if required by 327 IAC 3-2) within fourteen (14) months from the effective date of the permit. The permittee shall submit a written progress report to the Compliance Data Section, Office of Water Quality at this time.
3. Initiation of construction, if necessary, shall commence not later than the twenty-three (23) months from the effective date of the permit. The permittee shall submit a written progress report to the Compliance Data Section, Office of Water Quality at this time.
4. The permittee shall submit a written progress report to the Compliance Data Section, Office of Water Quality thirty-two (32) months from the effective date of the permit.
5. Construction shall be completed within thirty-five (35) months from the effective date of the permit. The permittee shall submit a written progress report to the Compliance Data Section, Office of Water Quality when construction has been completed.
6. The permittee shall comply with all final requirements no later than thirty-six (36) months from the effective date of the permit.
7. If the permittee fails to comply with any deadline contained in the foregoing schedule, the permittee shall, within fourteen (14) days following the missed deadline, submit a written notice of noncompliance to the Compliance Data Section of the Office of Water Quality stating the cause of noncompliance, any remedial action taken or planned, and the probability of meeting the date fixed for compliance with final effluent limitations.

## PART II

### STANDARD CONDITIONS FOR NPDES PERMITS

#### A. GENERAL CONDITIONS

##### 1. Duty to Comply

The permittee shall comply with all terms and conditions of this permit in accordance with 327 IAC 5-2-8(1) and all other requirements of 327 IAC 5-2-8. Any permit noncompliance constitutes a violation of the Clean Water Act and IC 13 and is grounds for enforcement action or permit termination, revocation and reissuance, modification, or denial of a permit renewal application.

It shall not be a defense for a permittee in an enforcement action that it would have been necessary to halt or reduce the permitted activity in order to maintain compliance with the conditions of the permit.

##### 2. Duty to Mitigate

In accordance with 327 IAC 5-2-8(3), the permittee shall take all reasonable steps to minimize or correct any adverse impact to the environment resulting from noncompliance with this permit. During periods of noncompliance, the permittee shall conduct such accelerated or additional monitoring for the affected parameters, as appropriate or as requested by IDEM, to determine the nature and impact of the noncompliance.

##### 3. Duty to Provide Information

The permittee shall submit any information that the permittee knows or has reason to believe would constitute cause for modification or revocation and reissuance of the permit at the earliest time such information becomes available, such as plans for physical alterations or additions to the facility that:

- a. could significantly change the nature of, or increase the quantity of, pollutants discharged; or
- b. the Commissioner may request to evaluate whether such cause exists.

In accordance with 327 IAC 5-1-3(a)(5), the permittee must also provide any information reasonably requested by the Commissioner.

##### 4. Duty to Reapply

If the permittee wishes to continue an activity regulated by this permit after the expiration date of this permit, the permittee must obtain and submit a renewal of this permit in accordance with 327 IAC 5-3-2(a)(2). It is the permittee's

responsibility to obtain and submit the application. In accordance with 327 IAC 5-2-3(c), the owner of the facility or operation from which a discharge of pollutants occurs is responsible for applying for and obtaining the NPDES permit, except where the facility or operation is operated by a person other than an employee of the owner in which case it is the operator's responsibility to apply for and obtain the permit. The application must be submitted at least 180 days before the expiration date of this permit. This deadline may be extended if:

- a. permission is requested in writing before such deadline;
- b. IDEM grants permission to submit the application after the deadline; and
- c. the application is received no later than the permit expiration date.

As required under 327 IAC 5-2-3(g)(1) and (2), POTWs with design influent flows equal to or greater than one million (1,000,000) gallons per day and POTWs with an approved pretreatment program or that are required to develop a pretreatment program, will be required to provide the results of whole effluent toxicity testing as part of their NPDES renewal application.

## 5. Transfers

In accordance with 327 IAC 5-2-8(4)(D), this permit is nontransferable to any person except in accordance with 327 IAC 5-2-6(c). This permit may be transferred to another person by the permittee, without modification or revocation and reissuance being required under 327 IAC 5-2-16(c)(1) or 16(e)(4), if the following occurs:

- a. the current permittee notified the Commissioner at least thirty (30) days in advance of the proposed transfer date.
- b. a written agreement containing a specific date of transfer of permit responsibility and coverage between the current permittee and the transferee (including acknowledgment that the existing permittee is liable for violations up to that date, and the transferee is liable for violations from that date on) is submitted to the Commissioner.
- c. the transferee certifies in writing to the Commissioner their intent to operate the facility without making such material and substantial alterations or additions to the facility as would significantly change the nature or quantities of pollutants discharged and thus constitute cause for permit modification under 327 IAC 5-2-16(d). However, the Commissioner may allow a temporary transfer of the permit without permit modification for good cause, e.g., to enable the transferee to purge and empty the facility's treatment system prior to making alterations, despite the transferee's intent to make such material and substantial alterations or additions to the facility.

- d. the Commissioner, within thirty (30) days, does not notify the current permittee and the transferee of the intent to modify, revoke and reissue, or terminate the permit and to require that a new application be filed rather than agreeing to the transfer of the permit.

The Commissioner may require modification or revocation and reissuance of the permit to identify the new permittee and incorporate such other requirements as may be necessary under the Clean Water Act or state law.

## 6. Permit Actions

In accordance with 327 IAC 5-2-16(b) and 327 IAC 5-2-8(4), this permit may be modified, revoked and reissued, or terminated for cause, including, but not limited to, the following:

- a. Violation of any terms or conditions of this permit;
- b. Failure of the permittee to disclose fully all relevant facts or misrepresentation of any relevant facts in the application, or during the permit issuance process; or
- c. A change in any condition that requires either a temporary or permanent reduction or elimination of the authorized discharge controlled by the permittee (e.g., plant closure, termination of the discharge by connecting to a POTW, a change in state law or information indicating the discharge poses a substantial threat to human health or welfare).

Filing of either of the following items does not stay or suspend any permit condition: (1) a request by the permittee for a permit modification, revocation and reissuance, or termination, or (2) submittal of information specified in Part II.A.3 of the permit including planned changes or anticipated noncompliance.

The permittee shall submit any information that the permittee knows or has reason to believe would constitute cause for modification or revocation and reissuance of the permit at the earliest time such information becomes available, such as plans for physical alterations or additions to the permitted facility that:

1. could significantly change the nature of, or increase the quantity of, pollutants discharged; or
2. the commissioner may request to evaluate whether such cause exists.

## 7. Property Rights

Pursuant to 327 IAC 5-2-8(6) and 327 IAC 5-2-5(b), the issuance of this permit does not convey any property rights of any sort or any exclusive privileges, nor does it authorize any injury to persons or private property or an invasion of rights,

any infringement of federal, state, or local laws or regulations. The issuance of the permit also does not preempt any duty to obtain any other state, or local assent required by law for the discharge or for the construction or operation of the facility from which a discharge is made.

8. Severability

In accordance with 327 IAC 1-1-3, the provisions of this permit are severable and, if any provision of this permit or the application of any provision of this permit to any person or circumstance is held invalid, the invalidity shall not affect any other provisions or applications of the permit which can be given effect without the invalid provision or application.

9. Oil and Hazardous Substance Liability

Nothing in this permit shall be construed to relieve the permittee from any responsibilities, liabilities, or penalties to which the permittee is or may be subject to under Section 311 of the Clean Water Act.

10. State Laws

Nothing in this permit shall be construed to preclude the institution of any legal action or relieve the permittee from any responsibilities, liabilities, or penalties established pursuant to any applicable state law or regulation under authority preserved by Section 510 of the Clean Water Act or state law.

11. Penalties for Violation of Permit Conditions

Pursuant to IC 13-30-4, a person who violates any provision of this permit, the water pollution control laws; environmental management laws; or a rule or standard adopted by the Environmental Rules Board is liable for a civil penalty not to exceed twenty-five thousand dollars (\$25,000) per day of any violation.

Pursuant to IC 13-30-5, a person who obstructs, delays, resists, prevents, or interferes with (1) the department; or (2) the department's personnel or designated agent in the performance of an inspection or investigation performed under IC 13-14-2-2 commits a class C infraction.

Pursuant to IC 13-30-10-1.5(e), a person who willfully or negligently violates any NPDES permit condition or filing requirement, or any applicable standards or limitations of IC 13-18-3-2.4, IC 13-18-4-5, IC 13-18-12, IC 13-18-14, IC 13-18-15, or IC 13-18-16, commits a Class A misdemeanor.

Pursuant to IC 13-30-10-1.5(i), an offense under IC 13-30-10-1.5(e) is a Level 4 felony if the person knowingly commits the offense or knows that the commission of the offense places another person in imminent danger of death or serious bodily injury. An offense under IC 13-30-10-1.5(e) is a Level 3 felony if it results in

serious bodily injury to any person, and a Level 2 felony if it results in death to any person.

Pursuant to IC 13-30-10-1.5(g), a person who willfully or recklessly violates any applicable standards or limitations of IC 13-18-8 commits a Class B misdemeanor.

Pursuant to IC 13-30-10-1.5(h), a person who willfully or recklessly violates any applicable standards or limitations of IC 13-18-9, IC 13-18-10, or IC 13-18-10.5 commits a Class C misdemeanor.

Pursuant to IC 13-30-10-1, a person who knowingly or intentionally makes any false material statement, representation, or certification in any NPDES form, notice, or report commits a Class B misdemeanor.

## 12. Penalties for Tampering or Falsification

In accordance with 327 IAC 5-2-8(10), the permittee shall comply with monitoring, recording, and reporting requirements of this permit. The Clean Water Act, as well as IC 13-30-10-1, provides that any person who knowingly or intentionally (a) destroys, alters, conceals, or falsely certifies a record, (b) tampers with, falsifies, or renders inaccurate or inoperative a recording or monitoring device or method, including the data gathered from the device or method, or (c) makes a false material statement or representation in any label, manifest, record, report, or other document; all required to be maintained under the terms of a permit issued by the department commits a Class B misdemeanor.

## 13. Toxic Pollutants

If any applicable effluent standard or prohibition (including any schedule of compliance specified in such effluent standard or prohibition) is established under Section 307(a) of the Clean Water Act for a toxic pollutant injurious to human health, and that standard or prohibition is more stringent than any limitation for such pollutant in this permit, this permit shall be modified or revoked and reissued to conform to the toxic effluent standard or prohibition in accordance with 327 IAC 5-2-8(5). Effluent standards or prohibitions established under Section 307(a) of the Clean Water Act for toxic pollutants injurious to human health are effective and must be complied with, if applicable to the permittee, within the time provided in the implementing regulations, even absent permit modification.

## 14. Operator Certification

The permittee shall have the wastewater treatment facilities under the responsible charge of an operator certified by the Commissioner in a classification corresponding to the classification of the wastewater treatment plant as required by IC 13-18-11-11 and 327 IAC 5-23-6. In order to operate a wastewater treatment plant, the operator shall have qualifications as established in 327 IAC 5-

23-3. The permittee shall designate one (1) person as the certified operator with complete responsibility for the proper operations of the wastewater facility.

327 IAC 5-23-7(b) provides that a certified operator may be designated as being in responsible charge of more than one (1) wastewater treatment plant, if it can be shown that he will give adequate supervision to all units involved. Adequate supervision means that sufficient time is spent at the plant on a regular basis to assure that the certified operator is knowledgeable of the actual operations and that test reports and results are representative of the actual operations conditions. In accordance with 327 IAC 5-23-2(16), "responsible charge" means the person responsible for the overall daily operation, supervision, or management of a wastewater facility.

Pursuant to 327 IAC 5-23-6(4)(A), the permittee shall notify IDEM when there is a change of the person serving as the certified operator in responsible charge of the wastewater treatment facility. The notification shall be made no later than thirty (30) days after a change in the operator.

#### 15. Construction Permit

Except in accordance with 327 IAC 3, the permittee shall not construct, install, or modify any water pollution treatment/control facility as defined in 327 IAC 3-1-2(24). Upon completion of any construction, the permittee must notify the Compliance Data Section of the Office of Water Quality in writing.

#### 16. Inspection and Entry

In accordance with 327 IAC 5-2-8(8), the permittee shall allow the Commissioner, or an authorized representative, (including an authorized contractor acting as a representative of the Commissioner) upon the presentation of credentials and other documents as may be required by law, to:

- a. Enter upon the permittee's premises where a point source, regulated facility, or activity is located or conducted, or where records must be kept pursuant to the conditions of this permit;
- b. Have access to and copy, at reasonable times, any records that must be kept under the terms and conditions of this permit;
- c. Inspect at reasonable times any facilities, equipment or methods (including monitoring and control equipment), practices, or operations regulated or required pursuant to this permit; and
- d. Sample or monitor at reasonable times, any discharge of pollutants or internal wastestreams for the purposes of evaluating compliance with the permit or as otherwise authorized.

## 17. New or Increased Discharge of Pollutants

This permit prohibits the permittee from undertaking any action that would result in a new or increased discharge of a bioaccumulative chemical of concern (BCC) or a new or increased permit limit for a regulated pollutant that is not a BCC unless one of the following is completed prior to the commencement of the action:

- a. Information is submitted to the Commissioner demonstrating that the proposed new or increased discharges will not cause a significant lowering of water quality as defined under 327 IAC 2-1.3-2(50). Upon review of this information, the Commissioner may request additional information or may determine that the proposed increase is a significant lowering of water quality and require the submittal of an antidegradation demonstration.
- b. An antidegradation demonstration is submitted to and approved by the Commissioner in accordance with 327 IAC 2-1.3-5 and 327 IAC 2-1.3-6.

## B. MANAGEMENT REQUIREMENTS

### 1. Facility Operations, Maintenance, and Quality Control

- a. In accordance with 327 IAC 5-2-8(9), the permittee shall at all times maintain in good working order and efficiently operate all facilities and systems (and related appurtenances, i.e., equipment used for measuring and determining compliance) for collection and treatment that are:

(1) installed or used by the permittee; and

(2) necessary for achieving compliance with the terms and conditions of the permit.

Neither 327 IAC 5-2-8(9), nor this provision, shall be construed to require the operation of installed treatment facilities that are unnecessary for achieving compliance with the terms and conditions of the permit. This provision also does not prohibit taking redundant treatment units offline, provided that the permittee is at all times: maintaining in good working order and efficiently operating all facilities and systems; providing best quality effluent; and achieving compliance with the terms and conditions of the permit.

- b. The permittee shall operate the permitted facility in a manner which will minimize upsets and discharges of excessive pollutants. The permittee shall properly remove and dispose of excessive solids and sludges.
- c. The permittee shall provide an adequate operating staff which is duly qualified to carry out the operation, maintenance, and testing functions required to ensure compliance with the conditions of this permit.

- d. Maintenance of all waste collection, control, treatment, and disposal facilities shall be conducted in a manner that complies with the bypass provisions set forth below.
- e. Pursuant to 327 IAC 5-23-6(1), the permittee is responsible for providing adequate funding for and oversight of the wastewater treatment plant and collection system to ensure proper operation, maintenance, management, and supervision.
- f. Any extensions to the sewer system must continue to be constructed on a separated basis. Plans and specifications, when required, for extension of the sanitary system must be submitted to the Facility Construction and Engineering Support Section, Office of Water Quality in accordance with 327 IAC 3-2-2. There shall also be an ongoing preventative maintenance program for the sanitary sewer system.

2. Bypass of Treatment Facilities

Pursuant to 327 IAC 5-2-8(12):

- a. Terms as defined in 327 IAC 5-2-8(12)(A):
  - (1) "Bypass" means the intentional diversion of a waste stream from any portion of a treatment facility.
  - (2) "Severe property damage" means substantial physical damage to property, damage to the treatment facilities which would cause them to become inoperable, or substantial and permanent loss of natural resources which can reasonably be expected to occur in the absence of a bypass. Severe property damage does not mean economic loss caused by delays in production.
- b. Bypasses, as defined above, are prohibited, and the Commissioner may take enforcement action against a permittee for bypass, unless:
  - (1) The bypass was unavoidable to prevent loss of life, personal injury, or severe property damage, as defined above;
  - (2) There were no feasible alternatives to the bypass, such as the use of auxiliary treatment facilities, retention of untreated wastes, or maintenance during normal periods of equipment downtime. This condition is not satisfied if adequate back up equipment should have been installed in the exercise of reasonable engineering judgment to prevent a bypass that occurred during normal periods of equipment downtime or preventive maintenance; and
  - (3) The permittee submitted notices as required under Part II.B.2.d; or

- (4) The condition under Part II.B.2.f below is met.
- c. Bypasses that result in death or acute injury or illness to animals or humans must be reported in accordance with the “Spill Response and Reporting Requirements” in 327 IAC 2-6.1, including calling 888/233-7745 as soon as possible, but within two (2) hours of discovery. However, under 327 IAC 2-6.1-3(1), when the constituents of the bypass are regulated by this permit, and death or acute injury or illness to animals or humans does not occur, the reporting requirements of 327 IAC 2-6.1 do not apply.
- d. The permittee must provide the Commissioner with the following notice:
- (1) If the permittee knows or should have known in advance of the need for a bypass (anticipated bypass), it shall submit prior written notice. If possible, such notice shall be provided at least ten (10) days before the date of the bypass for approval by the Commissioner.
- (2) The permittee shall orally report an unanticipated bypass within 24 hours of becoming aware of the bypass event. The permittee must also provide a written report within five (5) days of the time the permittee becomes aware of the bypass event. **Note that electronic submission will be the only acceptable method after December 21, 2025.** The report must contain a description of the noncompliance (i.e. the bypass) and its cause; the period of noncompliance, including exact dates and times; if the cause of noncompliance has not been corrected, the anticipated time it is expected to continue; and steps taken or planned to reduce, eliminate and prevent recurrence of the bypass event. If a complete email submittal is sent within 24 hours of the time that the permittee became aware of the unanticipated bypass event, then that report will satisfy both the oral and written reporting requirement.
- e. The Commissioner may approve an anticipated bypass, after considering its adverse effects, if the Commissioner determines that it will meet the conditions listed above in Part II.B.2.b. The Commissioner may impose any conditions determined to be necessary to minimize any adverse effects.
- f. The permittee may allow any bypass to occur that does not cause a violation of the effluent limitations in the permit, but only if it also is for essential maintenance to ensure efficient operation. These bypasses are not subject to the provisions of Part II.B.2.b., d and e of this permit.
3. Upset Conditions

Pursuant to 327 IAC 5-2-8(13):

- a. “Upset” means an exceptional incident in which there is unintentional and temporary noncompliance with technology-based permit effluent limitations

- because of factors beyond the reasonable control of the permittee. An upset does not include noncompliance to the extent caused by operational error, improperly designed treatment facilities, inadequate treatment facilities, lack of preventive maintenance, or careless or improper operation.
- b. An upset shall constitute an affirmative defense to an action brought for noncompliance with such technology-based permit effluent limitations if the requirements of Paragraph c of this subsection, are met.
  - c. A permittee who wishes to establish the affirmative defense of upset shall demonstrate, through properly signed, contemporaneous operating logs or other relevant evidence, that:
    - (1) An upset occurred and the permittee has identified the specific cause(s) of the upset;
    - (2) The permitted facility was at the time being operated in compliance with proper operation and maintenance procedures;
    - (3) The permittee complied with any remedial measures required under “Duty to Mitigate”, Part II.A.2; and
    - (4) The permittee submitted notice of the upset as required in the “Incident Reporting Requirements,” Part II.C.3, or 327 IAC 2-6.1, whichever is applicable. However, under 327 IAC 2-6.1-3(1), when the constituents of the discharge are regulated by this permit, and death or acute injury or illness to animals or humans does not occur, the reporting requirements of 327 IAC 2-6.1 do not apply.
  - d. In any enforcement proceeding, the permittee seeking to establish the occurrence of an upset has the burden of proof pursuant to 40 CFR 122.41(n)(4).

#### 4. Removed Substances

Solids, sludges, filter backwash, or other pollutants removed from or resulting from treatment or control of wastewaters shall be disposed of in a manner such as to prevent any pollutant from such materials from entering waters of the State and to be in compliance with all Indiana statutes and regulations relative to liquid and/or solid waste disposal.

- a. Collected screenings, slurries, sludges, and other such pollutants shall be disposed of in accordance with provisions set forth in 329 IAC 10, 327 IAC 6.1, or another method approved by the Commissioner.

- b. The permittee shall comply with existing federal regulations governing solids disposal, and with applicable provisions of 40 CFR Part 503, the federal sludge disposal regulation standards.
- c. The permittee shall notify the Commissioner prior to any changes in sludge use or disposal practices.
- d. The permittee shall maintain records to demonstrate its compliance with the above disposal requirements.

5. Power Failures

In accordance with 327 IAC 5-2-10 and 327 IAC 5-2-8(14) in order to maintain compliance with the effluent limitations and prohibitions of this permit, the permittee shall either:

- a. provide an alternative power source sufficient to operate facilities utilized by the permittee to maintain compliance with the effluent limitations and conditions of this permit, or
- b. shall halt, reduce or otherwise control all discharge in order to maintain compliance with the effluent limitations and conditions of this permit upon the reduction, loss, or failure of one or more of the primary sources of power to facilities utilized by the permittee to maintain compliance with the effluent limitations and conditions of this permit.

6. Unauthorized Discharge

Any overflow or release of sanitary wastewater from the wastewater treatment facilities or collection system that results in a discharge to waters of the state and is not specifically authorized by this permit is expressly prohibited. These discharges are subject to the reporting requirements in Part II.C.3 of this permit.

C. REPORTING REQUIREMENTS

1. Planned Changes in Facility or Discharge

Pursuant to 327 IAC 5-2-8(11)(F) and 5-2-16(d), the permittee shall give notice to the Commissioner as soon as possible of any planned alterations or additions to the facility (which includes any point source) that could significantly change the nature of, or increase the quantity of, pollutants discharged. Following such notice, the permit may be modified to revise existing pollutant limitations and/or to specify and limit any pollutants not previously limited. Material and substantial alterations or additions to the permittee's operation that were not covered in the permit (e.g., production changes, relocation or combination of discharge points, changes in the nature or mix of products produced) are also cause for modification of the permit. However, those alterations which constitute total

replacement of the process or the production equipment causing the discharge converts it into a new source, which requires the submittal of a new NPDES application.

2. Monitoring Reports

Pursuant to 327 IAC 5-2-8(10), 327 IAC 5-2-13, and 327 IAC 5-2-15, monitoring results shall be reported at the intervals and in the form specified in "Data On Plant Operation", Part I.B.2.

3. Incident Reporting Requirements

Pursuant to 327 IAC 5-2-8(11) and 327 IAC 5-1-3, the permittee shall orally report to the Commissioner information on the following incidents within 24 hours from the time permittee becomes aware of such occurrence. If the incident meets the emergency criteria of item b (Part II.C.3.b) or 327 IAC 2-6.1, then the report shall be made as soon as possible, but within two (2) hours of discovery. However, under 327 IAC 2-6.1-3(1), when the constituents of the discharge are regulated by this permit, and death or acute injury or illness to animals or humans does not occur, the reporting requirements of 327 IAC 2-6.1 do not apply.

- a. Any unanticipated bypass which exceeds any effluent limitation in the permit;
- b. Any emergency incident which may pose a significant danger to human health or the environment. Reports under this item shall be made as soon as the permittee becomes aware of the incident by calling 317/233-7745 (888/233-7745 toll free in Indiana). This number should only be called when reporting these emergency events;
- c. Any upset (as defined in Part II.B.3 above) that exceeds any technology-based effluent limitations in the permit;
- d. Any release, including basement backups, from the sanitary sewer system (including satellite sewer systems operated or maintained by the permittee) not specifically authorized by this permit. Reporting of known releases from private laterals not caused by a problem in the sewer system owned or operated by the permittee is not required under Part II.C.3, however, documentation of such events must be maintained by the permittee and available for review by IDEM staff;
- e. Any discharge from any outfall from which discharge is explicitly prohibited by this permit as well as any discharge from any other outfall or point not listed in this permit; or
- f. Violation of a maximum daily discharge limitation for any of the following toxic pollutants: copper, mercury, selenium, and silver.

The permittee can make the oral reports by calling 317/232-8670 during regular business hours and asking for the Compliance Data Section, or by calling (317/233-7745) (888/233-7745 toll free in Indiana) during non-business hours. A written submission shall also be provided within five (5) days of the time the permittee becomes aware of the circumstances. The written submission shall contain: a description of the event and its cause; the period of occurrence, including exact dates and times, and, if the event has not concluded, the anticipated time it is expected to continue; and steps taken or planned to reduce, mitigate and eliminate the event and steps taken or planned to prevent its recurrence. The Commissioner may waive the written report on a case-by-case basis if the oral report has been received within 24 hours. Alternatively, the permittee may submit a "Bypass/Overflow Incident Report" (State Form 48373) or a "Noncompliance Notification Report" (State Form 54215), whichever is appropriate, to IDEM at [wwreports@idem.IN.gov](mailto:wwreports@idem.IN.gov). If a complete submittal is sent within 24 hours of the time that the permittee became aware of the occurrence, then that report will satisfy both the oral and written reporting requirements.

4. Other Noncompliance

Pursuant to 327 IAC 5-2-8(11)(D), the permittee shall report any instance of noncompliance not reported under the "Incident Reporting Requirements" in Part II.C.3 at the time the pertinent Discharge Monitoring Report is submitted. The written submission shall contain: a description of the noncompliance and its cause; the period of noncompliance, including exact dates and times, and, if the noncompliance has not been corrected, the anticipated time it is expected to continue; and steps taken or planned to reduce, eliminate and prevent the noncompliance.

5. Other Information

Pursuant to 327 IAC 5-2-8(11)(E), where the permittee becomes aware that it failed to submit any relevant facts or submitted incorrect information in a permit application or in any report to the Commissioner, the permittee shall promptly submit such facts or corrected information to the Commissioner.

6. Signatory Requirements

Pursuant to 327 IAC 5-2-22 and 327 IAC 5-2-8(15):

- a. All reports required by the permit and other information requested by the Commissioner shall be signed and certified by a person described below or by a duly authorized representative of that person:

- (1) For a corporation: by a principal executive defined as a president, secretary, treasurer, any vice-president of the corporation in charge of a principal business function, or any other person who performs similar policy-making functions for the corporation or the manager of one or more

manufacturing, production, or operating facilities employing more than two hundred fifty (250) persons or having gross annual sales or expenditures exceeding twenty-five million dollars (\$25,000,000) (in second quarter 1980 dollars), if authority to sign documents has been assigned or delegated to the manager in accordance with corporate procedures.

- (2) For a partnership or sole proprietorship: by a general partner or the proprietor, respectively; or
  - (3) For a federal, state, or local governmental body or any agency or political subdivision thereof: by either a principal executive officer or ranking elected official.
- b. A person is a duly authorized representative only if:
- (1) The authorization is made in writing by a person described above.
  - (2) The authorization specifies either an individual or a position having responsibility for the overall operation of the regulated facility or activity, such as the position of plant manager, operator of a well or a well field, superintendent, or position of equivalent responsibility. (A duly authorized representative may thus be either a named individual or any individual occupying a named position.); and
  - (3) The authorization is submitted to the Commissioner.
- c. Electronic Signatures. If documents described in this section are submitted electronically by or on behalf of the NPDES-regulated facility, any person providing the electronic signature for such documents shall meet all relevant requirements of this section, and shall ensure that all of the relevant requirements of 40 CFR part 3 (including, in all cases, subpart D to part 3) (Cross-Media Electronic Reporting) and 40 CFR part 127 (NPDES Electronic Reporting Requirements) are met for that submission.
- d. Certification. Any person signing a document identified under paragraphs a and b of this section, shall make the following certification:

“I certify under penalty of law that this document and all attachments were prepared under my direction or supervision in accordance with a system designed to assure that qualified personnel properly gather and evaluate the information submitted. Based on my inquiry of the person or persons who manage the system, or those persons directly responsible for gathering the information, the information submitted is, to the best of my knowledge and belief, true, accurate, and complete. I am aware that there are significant penalties for submitting false information, including the possibility of fine and imprisonment for knowing violations.”

7. Availability of Reports

Except for data determined to be confidential under 327 IAC 12.1, all reports prepared in accordance with the terms of this permit shall be available for public inspection at the offices of the Indiana Department of Environmental Management and the Regional Administrator. As required by the Clean Water Act, permit applications, permits, and effluent data shall not be considered confidential.

8. Penalties for Falsification of Reports

IC 13-30 and 327 IAC 5-2-8(15) provides that any person who knowingly makes any false statement, representation, or certification in any record or other document submitted or required to be maintained under this permit, including monitoring reports or reports of compliance or noncompliance, shall, upon conviction, be punished by a fine of not more than \$10,000 per violation, or by imprisonment for not more than 180 days per violation, or by both.

9. Progress Reports

In accordance with 327 IAC 5-2-8(11)(A), reports of compliance or noncompliance with, or any progress reports on, interim and final requirements contained in any compliance schedule of this permit shall be submitted no later than fourteen (14) days following each schedule date.

10. Advance Notice for Planned Changes

In accordance with 327 IAC 5-2-8(11)(B), the permittee shall give advance notice to IDEM of any planned changes in the permitted facility, any activity, or other circumstances that the permittee has reason to believe may result in noncompliance with permit requirements.

11. Additional Requirements for POTWs and/or Treatment Works Treating Domestic Sewage

- a. All POTWs shall identify, in terms of character and volume of pollutants, any significant indirect discharges into the POTW which are subject to pretreatment standards under section 307(b) and 307 (c) of the CWA.
- b. All POTWs must provide adequate notice to the Commissioner of the following:
  - (1) Any new introduction of pollutants into the POTW from an indirect discharger that would be subject to section 301 or 306 of the CWA if it were directly discharging those pollutants.
  - (2) Any substantial change in the volume or character of pollutants being introduced into that POTW by any source where such change would render

the source subject to pretreatment standards under section 307(b) or 307(c) of the CWA or would result in a modified application of such standards.

As used in this clause, “adequate notice” includes information on the quality and quantity of effluent introduced into the POTW, and any anticipated impact of the change on the quantity or quality of the effluent to be discharged from the POTW.

- c. This permit incorporates any conditions imposed in grants made by the U.S. EPA and/or IDEM to a POTW pursuant to Sections 201 and 204 of the Clean Water Act, that are reasonably necessary for the achievement of effluent limitations required by Section 301 of the Clean Water Act.
- d. This permit incorporates any requirements of Section 405 of the Clean Water Act governing the disposal of sewage sludge from POTWs or any other treatment works treating domestic sewage for any use for which rules have been established in accordance with any applicable rules.
- e. POTWs must develop and submit to the Commissioner a POTW pretreatment program when required by 40 CFR 403 and 327 IAC 5-19-1, in order to assure compliance by industrial users of the POTW with applicable pretreatment standards established under Sections 307(b) and 307(c) of the Clean Water Act. The pretreatment program shall meet the criteria of 327 IAC 5-19-3 and, once approved, shall be incorporated into the POTW's NPDES permit.

## 12. Electronic Reporting

IDEM is currently developing the technology and infrastructure necessary to allow compliance with the EPA Phase 2 e-reporting requirements per 40 CFR 127.16 and to allow electronic reporting of applications, notices, plans, reports, and other information not covered by the federal e-reporting regulations.

IDEM will notify the permittee when IDEM's e-reporting system is ready for use for one or more applications, notices, plans, reports, or other information. This IDEM notice will identify the specific applications, notices, plans, reports, or other information that are to be submitted electronically, and the permittee will be required to use the IDEM electronic reporting system to submit the identified application(s), notice(s), plan(s), report(s), or other information.

See Part I.B.3., Monthly Reporting, for the electronic reporting requirements for the monthly monitoring reports such as the Discharge Monitoring Report (DMR), Monthly Report of Operation (MRO) and Monthly Monitoring Report (MMR).

13. Trucked or Hauled Pollutants

The permittee shall prohibit the introduction of trucked or hauled pollutants into the treatment works, except under the following conditions:

- a. The permittee has provided prior written permission to the person seeking to discharge the hauled or trucked pollutants into the treatment works;
- b. The person seeking to discharge the hauled or trucked pollutants into the treatment works possesses a valid septage management permit, as required by IC 13-18-12 and 327 IAC 7.1;

- (1) The introduction of trucked or hauled industrial wastewaters into the treatment works is prohibited, unless the permittee receives approval per (2) and (3) below;

- (2) Approval for accepting hauled industrial wastewater must be obtained from the appropriate approval authority, whether that is IDEM or EPA, prior to the acceptance of the industrial wastewater in accordance with Part II.A.3, Part II.C.1 and Part II.C.10 of this permit;

- (3) Hauled wastewater permit conditions prohibit a POTW from accepting wastewater from CIUs (regardless of potential to significantly alter the nature or quantity of pollutants discharged as described in Part II.A.3) unless specifically authorized to do so by a federally approved pretreatment program.

- c. The pollutants are introduced into the treatment works via a discharge point designated by the permittee.

14. Hauled Waste Requirements

In the event that the permittee allows the introduction of trucked or hauled pollutants under the conditions specified in item 13 above, the permittee shall:

- a. Obtain and retain, for a minimum of forty-eight hours, samples that are representative of the hauled or trucked pollutants;
- b. Analyze the samples obtained pursuant to item "a" above in the event that the permittee believes or has reason to believe that the hauled or trucked pollutants may be causing and/or contributing to pass-through and/or interference;

- c. Maintain records, for each discharge of trucked or hauled pollutants into the treatment works, of the following:

- (1) Name of the person discharging the trucked or hauled pollutants;

- (2) Septage management permit number (if applicable) and BMV vehicle license plate number and expiration date;
- (3) Origination, volume, and nature of the trucked or hauled pollutants;
- (4) Date and time of the discharge;
- (5) Any sampling conducted; and
- (6) Analytical Results, if any.

#### D. ADDRESSES

##### 1. Municipal NPDES Permits Section

Indiana Department of Environmental Management  
Office of Water Quality – Rm 1255  
Municipal NPDES Permits Section  
100 N. Senate Avenue  
Indianapolis, Indiana 46204-2251

The following correspondence shall be sent to the Municipal NPDES Permits Section:

- a. NPDES permit applications (new, renewal or modifications) with fee
- b. Preliminary Effluent Limits request letters
- c. Comment letters pertaining to draft NPDES permits
- d. NPDES permit transfer of ownership requests
- e. NPDES permit termination requests
- f. Notifications of substantial changes to a treatment facility, including new industrial sources
- g. Combined Sewer Overflow (CSO) Operational Plans
- h. CSO Long Term Control Plans (LTCP)
- i. Stream Reach Characterization and Evaluation Reports (SRCER)
- j. Streamlined Mercury Variance Annual Reports

2. Facility Construction and Engineering Support Section

Indiana Department of Environmental Management  
Office of Water Quality – Rm 1255  
Facility Construction and Engineering Support Section  
100 N. Senate Avenue  
Indianapolis, Indiana 46204-2251

The following correspondence shall be sent to the Facility Construction and Engineering Support Section:

- a. Construction permit applications with fee

3. Compliance Data Section

Indiana Department of Environmental Management  
Office of Water Quality – Rm 1255  
Compliance Data Section  
100 N. Senate Avenue  
Indianapolis, Indiana 46204-2251

The following correspondence shall be sent to the Compliance Data Section:

- a. Discharge Monitoring Reports (DMRs)
- b. Monthly Reports of Operation (MROs)
- c. Monthly Monitoring Reports (MMRs)
- d. CSO MROs
- e. Gauging station and flow meter calibration documentation
- f. Compliance schedule progress reports
- g. Completion of Construction notifications
- h. Whole Effluent Toxicity (WET) Testing reports
- i. Notification of two (2) consecutive failed WETTs and the intent to begin implementation of a TRE
- j. Notification of initiation of a TRE
- k. TRE plans and progress reports
- l. TRE final report

- m. Bypass/Overflow Reports
- n. Anticipated Bypass/Overflow Reports

4. Pretreatment Group

Indiana Department of Environmental Management  
Office of Water Quality – Rm 1255  
Compliance Data Section – Pretreatment Group  
100 N. Senate Avenue  
Indianapolis, Indiana 46204-2251

The following correspondence shall be sent to the Pretreatment Group:

- a. Priority Pollutant Reports
- b. Significant Industrial User (SIU) Quarterly Noncompliance Reports
- c. Pretreatment Program Annual Reports
- d. Sewer Use Ordinances
- e. Enforcement Response Plans (ERP)
- f. Sludge analytical results

PART III

REQUIREMENT TO OPERATE  
A PRETREATMENT PROGRAM

A. CONDITIONS

The permittee, hereinafter referred to as the "Control Authority," is required to operate its approved industrial pretreatment program approved on **July 7, 1986**, and any subsequent modifications approved up to the issuance of this permit. To ensure the program is operated as approved and consistent with 327 IAC 5-16 through 5-21, the following conditions and reporting requirements are hereby established. The Control Authority (CA) shall:

1. Legal Authority

The CA shall develop, enforce and maintain adequate legal authority in its Sewer Use Ordinance (SUO) to fully implement the pretreatment program in compliance with State and local law. As part of this requirement, the CA shall develop and maintain local limits as necessary to implement the prohibitions and standards in 327 IAC 5-18.

2. Permit Issuance

In accordance with 327 IAC 5-19-3(1) the CA is required to issue/reissue permits to Significant Industrial User(s) (SIU) as stated in the SUO. The CA must issue permits to new SIUs prior to the commencement of discharge. A SIU is defined in the SUO.

3. Industrial Compliance Monitoring

The CA is required to conduct inspection, surveillance, and monitoring activities to determine SIU compliance status with the approved program and the SUO independent of data supplied by the SIU. SIU compliance monitoring performed by the CA will be conducted in accordance with the program plan or yearly program plan. SIUs will be inspected once per year, at a minimum.

4. Enforcement

The CA is required to initiate the appropriate enforcement action against a SIU violating any provision of the SUO and/or discharge permit in accordance with the Enforcement Response Plan (ERP) adopted by the CA. The CA must investigate violations by collecting and analyzing samples and collecting other information with sufficient care to produce evidence admissible in enforcement proceedings or in judicial actions in accordance with 40 CFR 403.8(f)(1)(iii) and 327 IAC 5-19-3(1)(F).

5. SIU Quarterly Noncompliance Report

The CA is required to report the compliance status of each SIU quarterly. The report is due by the 28th of the following months: April, July, October, and January of each year. The report shall include a description of corrective actions that have or will be taken by the CA and SIU to resolve the noncompliance situations. This report is to be sent to the Compliance Branch of the Office of Water Quality.

6. Public Participation and Annual Publishing of SIUs in Significant Noncompliance

The CA is required to comply with the public participation requirements under 40 CFR 25 and 327 IAC 5-19-3(2)(L). The CA must publish annually, by January 28, in the largest daily newspaper in the area, a list of SIUs that have been in Significant Noncompliance (SNC) with the SUO during the calendar year. The CA shall include in the ANNUAL REPORT a list of the SIUs published along with the newspaper clipping.

7. Industrial User Survey

The CA shall prepare and maintain a list of its Industrial Users meeting the criteria in 40 CFR 403.3(v)(1). The list shall identify the criteria in 40 CFR 403.3(v)(1) applicable to each Industrial User and where applicable, shall also indicate whether the CA has made a determination pursuant to 40 CFR 403.3(v)(2) that such Industrial User should not be considered a Significant Industrial User. Modifications to the list shall be submitted to the Approval Authority pursuant to 40 CFR 403.12(i)(1).

8. Annual Report

The CA is required to submit an annual report to the Pretreatment Group and EPA Region 5 by April 1, of each year. The CA shall also include a copy of the updated industrial user survey list. The annual report will be submitted in accordance with 40 CFR 403.12(i) to the following addresses:

Pretreatment Program Manager  
U.S. EPA Region 5, ECW-15J  
Water Enforcement and Compliance Assurance Branch  
77 W. Jackson Blvd.  
Chicago, IL 60604  
[r5pretreatment@epa.gov](mailto:r5pretreatment@epa.gov)

Indiana Department of Environmental Management  
Office of Water Quality – Rm 1255  
Compliance Data Section – Pretreatment Group  
100 North Senate Avenue  
Indianapolis, IN 46204-2251

9. Records Retention

Pursuant to 327 IAC 5-16-5.3(b), the CA shall retain any pretreatment reports from an industrial user a minimum of three (3) years and shall make such reports available for inspection and copying by IDEM or the U.S. EPA. This period of retention shall be extended during the course of any unresolved litigation regarding the discharge of pollutants by the industrial user, the operation of the POTW pretreatment program or when requested by IDEM or the U.S. EPA.

10. Confidentiality

The CA is required to comply with all confidentiality requirements set forth in 40 CFR 403.14, as well as the procedures established in the SUO.

11. Program Resources

Pursuant to 327 IAC 5-19-3(3), The CA shall maintain sufficient resources and qualified personnel to carry out the pretreatment program requirements.

12. Interjurisdictional Agreements

The CA must maintain sufficient legal authority to ensure compliance with all applicable pretreatment limits and requirements by all SIUs discharging to the POTW, including SIUs within governmental jurisdictions outside the immediate jurisdiction of the POTW. The CA must maintain the interjurisdictional agreements necessary to ensure full compliance by SIUs located within other jurisdictions as discussed in 40 CFR 403.8(f)(1).

13. POTW Pretreatment Program Revision Requirements

No later than 6 months after the effective date of this permit, the permittee shall re-evaluate its SUO to determine whether it provides adequate legal authority to fully implement the pretreatment program. Any modifications to the permittee's SUO shall be consistent with U.S. EPA's EPA Model Pretreatment Ordinance, available at: [https://www3.epa.gov/npdes/pubs/pretreatment\\_model\\_suo.pdf](https://www3.epa.gov/npdes/pubs/pretreatment_model_suo.pdf)

In addition, the re-evaluation must include a technical re-evaluation of the local limits in accordance with 40 CFR 122.44(j)(2)(ii). The CA is to conduct the local limitations technical evaluation consistent with U.S. EPA's Local Limits Development Guidance (July 2004) document and U.S. EPA Region 5 Local Limits Spreadsheet (February 2011). The Development Guidance and the Local Limits Spreadsheet are available upon request through IDEM's Pretreatment Coordinator. The permittee shall submit the local limit re-evaluation to U.S. EPA Region 5 and IDEM Pretreatment Group for review. If any changes are deemed necessary to the SUO, the permittee shall notify the U.S. EPA Region 5 and IDEM Pretreatment Group.

14. Program Modification

Pursuant to 327 IAC 5-19-6 and 40 CFR 403.18, any significant proposed program modification shall be submitted to the Pretreatment Group and the U.S. EPA for approval. A significant modification shall include, but not be limited to, any change in the SUO, major modification in the approval program's administrative procedures, a significant reduction in monitoring procedures, a significant change in the financial/revenue system, a significant change in the local limitations contained in the SUO, and a change in the industrial user survey.

ATTACHMENT A

Combined Sewer Overflow (CSO) Requirements

I. CSO Outfalls

Discharges from CSO outfalls identified in the table below are to be reported in accordance with the requirements of Part III of this attachment. CSO discharge events will be periodically evaluated by IDEM to determine if such discharges are consistent with the CSO Level of Control (LOC) approved as part of the permittee's Long Term Control Plan (LTCP). The water quality-based requirements and performance criteria for CSO control are established by the approved LTCP, associated LOC, and this Attachment A. Discharges determined by IDEM to not be consistent with the approved LOC may result in corrective actions and/or additional CSO controls being required to ensure future CSO discharges meet the requirements of the approved LTCP.

Dry weather discharges from any portion of the sewer collection system, except WWTP Outfall No. 001, are prohibited. In addition to complying with the monitoring and reporting requirements in Part III of this attachment, the permittee is also required to report prohibited dry weather discharges in accordance with Part II.C.3 of this permit.

Outfall No.	Location	Receiving Stream
007	WWTP CS Diversion Pump Station 41° 35' 48" N 85° 51' 11" W	Elkhart River
008	Wet Weather CS Detention Facility 41° 35' 40" N 85° 51' 06" W	Elkhart River
009	CS Detention Facility Headworks Overflow 41° 35' 38" N 85° 50' 57" W	Elkhart River
010	Overflow from CS Pump Station 41° 35' 40" N 85° 51' 06" W	Elkhart River

Monitoring for the purpose of reporting on the CSO Monthly Report of Operation (State Form 50546 (R4/9-15)) shall be conducted at a location representative of untreated CSO discharges. Monitoring from a CSO regulator structure contributing flow to the CSO outfall is acceptable provided flows at this location are representative and comprised of untreated CSO flows ultimately discharged through the CSO outfall. Monitoring at the CSO outfall is considered representative except in those instances where non-CSO flows (treated effluents, separate stormwater, etc.) are also discharged through a common outfall. All non-CSO flows shall be excluded from reporting on the CSO Monthly Report of Operation.

## II. Minimum Narrative Limitations

- A. At all times the discharge from any and all CSO outfalls herein shall not cause receiving waters:
1. including waters within the mixing zone, to contain substances, materials, floating debris, oil, scum attributable to municipal, industrial, agricultural, and other land use practices, or other discharges that do any of the following:
    - a. will settle to form putrescent or otherwise objectionable deposits;
    - b. are in amounts sufficient to be unsightly or deleterious;
    - c. produce color, visible oil sheen, odor, or other conditions in such a degree as to create a nuisance;
    - d. are in amounts sufficient to be acutely toxic to, or otherwise severely injure or kill aquatic life, other animals, plants, or humans;
    - e. are in concentrations or combinations that will cause or contribute to the growth of aquatic plants or algae to such a degree as to create a nuisance, be unsightly, or otherwise impair the designated uses.
  2. outside the mixing zone, to contain substances in concentrations that on the basis of available scientific data are believed to be sufficient to injure, be chronically toxic to, or be carcinogenic, mutagenic, or teratogenic to humans, animals, aquatic life, or plants.
- B. Dry weather discharges from any portion of the sewer collection system, except WWTP outfall No. 001, are prohibited. If such a prohibited discharge should occur, the permittee is required to report the discharge in accordance with the provisions in Part II.C.3 of this permit.

## III. Monitoring and Reporting Requirements

The permittee shall complete and submit accurate monitoring reports to the Indiana Department of Environmental Management. The permittee shall submit data specified on the NPDES CSO Monthly Report of Operation (MRO) form (State Form 50546 (R5/11-21)). The CSO MRO form includes the following reporting parameters:

- Daily WWTP Influent Data: average daily flow, and peak hourly flow.
- Precipitation Data: time precipitation began, precipitation duration, total daily precipitation, peak precipitation intensity, and rain gauge measurement interval.
- CSO Outfall Information: time discharge began, whether the outfall is metered or estimated, event duration, amount of CSO discharge.

The permittee is required to report all discharges from untreated CSO Outfalls identified in Part I of this Attachment A. CSO MROs shall contain results obtained during each month (a monitoring period) and shall be submitted no later than 28 days following each completed monitoring period. All NPDES permit holders are now required to submit their monitoring data to IDEM using NetDMR.

#### IV. CSO Operational Plan

- A. The permittee shall comply with the following minimum technology-based controls, in accordance with EPA's National CSO Control Policy:
1. The permittee shall implement proper operation and regular maintenance programs for the sewer system and the CSOs. The purpose of the operation and maintenance programs is to reduce the magnitude, frequency and duration of CSOs. The programs shall consider regular sewer inspections; sewer, catch basin, and regulator cleaning; equipment and sewer collection system repair or replacement, where necessary; and disconnection of illegal connections.
  2. The permittee shall implement procedures that will maximize the use of collection system for wastewater storage that can be accommodated by the storage capacity of the collection system in order to reduce the magnitude, frequency and duration of CSOs.
  3. The permittee shall review and modify, as appropriate, its existing pretreatment program to minimize CSO impacts from non-domestic users. The permittee shall identify all industrial users that discharge to the collection system upstream of any CSO outfalls; this identification shall also include the pollutants in the industrial user's wastewater and the specific CSO outfall(s) that are likely to discharge the wastewater.
  4. The permittee shall operate the POTW at the maximum treatable flow during all wet weather flow conditions to reduce the magnitude, frequency and duration of CSOs. The permittee shall deliver all flows to the treatment plant within the constraints of the treatment capacity of the POTW.
  5. Dry weather overflows from CSO outfalls are prohibited. Each dry weather overflow must be reported to IDEM as soon as the permittee becomes aware of the overflow. When the permittee detects a dry weather overflow, it shall begin corrective action immediately. The permittee shall inspect the dry weather overflow each subsequent day until the overflow has been eliminated.
  6. The permittee shall implement measures to control solid and floatable materials in CSO discharges.
  7. The permittee shall implement a pollution prevention program focused on reducing the impact of CSOs on receiving waters.

8. The permittee shall implement a public notification process to inform citizens of when and where CSO discharges occur and their impacts. This notification must also be done in accordance with 327 IAC 5-2.1.
  9. The permittee shall monitor to effectively characterize CSO impacts and the efficacy of CSO controls.
- B. The permittee's implementation of each of the minimum controls in Part IV.A of this Attachment A shall be documented in its approved CSO Operational Plan (CSOOP). The permittee shall update the CSOOP, as necessary, to reflect changes in its operation or maintenance practices; changes to measures taken to implement the above minimum requirements; and changes to the treatment plant or collection system, including changes in collection system flow characteristics, collection system or WWTP capacity or discharge characteristics (including volume, duration, frequency and pollutant concentration). All updates to the CSOOP must be submitted to IDEM, Office of Water Quality, Municipal NPDES Permits Section for approval.

The CSOOP update(s) shall include a summary of the proposed revisions to the CSOOP as well as a reference to the page(s) that have been modified. Any CSOOP updates shall not result in:

1. a lower amount of flow being sent to and through the plant for treatment, or
2. more discharges (measured either by volume, duration, frequency, or pollutant concentration) occurring from the CSO outfalls.

The permittee shall maintain a current CSO Operational Plan, including all approved updates, on file at the POTW.

#### V. Sewer Use Ordinance Review/Revision and Enforcement

The permittee's Sewer Use Ordinance must contain provisions which: (1) prohibit introduction of inflow sources to any sanitary sewer; (2) prohibit construction of new combined sewers outside of the existing combined sewer service area; and (3) provide that for any new building the inflow/clear water connection to a combined sewer shall be made separate and distinct from sanitary waste connection to facilitate disconnection of the former if a separate storm sewer subsequently becomes available. The permittee shall continuously enforce these provisions.

#### VI. Reopening Clauses

- A. This permit may be reopened to address changes in the EPA National CSO Policy or state or federal law.
- B. The permit may be reopened, after public notice and opportunity for hearing, to incorporate applicable provisions of IC 13-18.

## ATTACHMENT B

### Streamlined Mercury Variance

#### I. Introduction

The permittee submitted an application for a streamlined mercury variance (SMV) in accordance with the provisions of 327 IAC 5-3.5. The SMV establishes a streamlined process for obtaining a variance from a water quality criterion used to establish a WQBEL for mercury in an NPDES permit. Based on a review of the SMV application, IDEM has determined the application to be complete as outlined in 327 IAC 5-3.5-4(e). Therefore, the SMV has been issued concurrently with the NPDES permit in accordance with 327 IAC 5-3.5-6.

#### II. Term of SMV

The SMV and the interim discharge limit will remain in effect until the NPDES permit expires under IC 13-14-8-9 (amended under SEA 620, May 2005). Pursuant to IC 13-14-8-9(e), when the NPDES permit is extended under IC 13-15-3-6 (administratively extended), the SMV will remain in effect as long as the NPDES permit requirements affected by the SMV are in effect.

#### III. Annual Reports

The annual report is a condition of the Pollutant Minimization Program Plan (PMPP) requirements of 327 IAC 5-3.5-9(a)(8). The annual report must describe the permittee's progress toward fulfilling each PMPP requirement, the results of all mercury monitoring within the previous year, and the steps taken to implement the planned activities outlined under the PMPP. The annual report will be due on **July 1** of each year.

#### IV. SMV Renewal

As authorized under 327 IAC 5-3.5-7(a)(1), the permittee may apply for the renewal of an SMV at any time within 180 days prior to the expiration of the NPDES permit. In accordance with 327 IAC 5-3.5-7(c), an application for renewal of the SMV must contain the following:

- A. All information required for an initial SMV application under 327 IAC 5-3.5-4, including revisions to the PMPP, if applicable.
- B. A report on implementation of each provision of the PMPP.
- C. An analysis of the mercury concentrations determined through sampling at the facility's locations that have mercury monitoring requirements in the NPDES permit for the two (2) year period prior to the SMV renewal application.

- D. A proposed alternative mercury discharge limit, if appropriate, to be evaluated by the department according to 327 IAC 5-3.5-8(b) based on the most recent two (2) years of representative sampling information from the facility.

Renewal of the SMV is subject to a demonstration showing that PMPP implementation has achieved progress toward the goal of reducing mercury from the discharge.

V. Pollutant Minimization Program Plan (PMPP)

The PMPP is a requirement of the SMV application and is defined in 327 IAC 5-3.5-3(4) as the plan for development and implementation of Pollutant Minimization Program (PMP). The PMP is defined in 327 IAC 5-3.5-3(3) as the program developed by an SMV applicant to identify and minimize the discharge of mercury into the environment. PMPP requirements are outlined in 327 IAC 5-3.5-9. In accordance with 327 IAC 5-3.5-6, the requirements of the PMPP are appended with this Attachment.

**Part II. A Pollutant Minimization Program Plan (PMPP) Inventory Evaluation**

Compliance Evaluation	Plan	Schedule
<u>Laboratory</u> a. Mercury Certified Thermometer b. No Barometers on site	No replacement at this time	None
<u>Bulk Chemicals</u> a. Sodium Hypochlorite b. Sodium Bisulfite c. Ferric Chloride	Mercury Reduced/Free requested during bidding process.	Every two years
<u>Process Controls</u> a. Flow Meters b. Gas regulators and meters c. Mercoid control switches and tilt switches d. Relay switches e. Float switches	All replace with non-mercury controls	Completed February 2011
<u>Building</u> a. Flame Sensors b. Aqua Stats c. Limit Switches d. Flow Controls e. Light Switches f. Relay Switches	All of the following have been researched and found to be non-mercury bearing.	None
<u>Lamps</u> a. Fluorescent Lamps b. High Pressure Sodium Necessary for explosion proof settings.	Over half of the WWTPs fluorescent lamps and fixtures were replaced with LED lighting in 2014-2015. Buildings include the office administration, laboratory, maintenance offices and lounge. Replaced the remaining fluorescent lamps and fixtures with LED lighting which was completed in early 2020.	ALL lights and fixtures at the WWTP including all buildings, driveway lights and tank lighting are LED. Completed in 2020
<u>First Aid/Medical</u> -Thimerosal - Found in eye wash solutions.	Researching alternatives	Laboratory has a permanent eyewash connected to city water.
<u>Other</u> a. Computer monitors and equipment b. Fleet vehicles	The City's IT department recycles all computers and electronic equipment.	Ongoing
<u>Collection System</u> -Sewer lines	Sewer lines are cleaned by the Water/Sewer Utility. Private lines are cleaned by the owner.	This process is ongoing with 20 - 25 percent of the sewer mains are televised and cleaned annually.

**Part II B. Inventory Plan and Schedule**

Planned Activity	Schedule for Action
Suppliers are asked to provide low level or mercury free products during the bidding	Every two years
An alternative product will be sought (ie. Ferric Chloride)	Ongoing
If no other product is available, the WWTP will research the need for the product and eliminate it if possible.	Ongoing
The product will be removed from the facility	As soon as possible
Waste materials or products that are no longer needed are disposed of in accordance with proper disposal procedures, including but not limited to returning them to the supplier or contracting with licensed disposal facilities.	Ongoing
The WWTP participates in "Beautify Goshen" week	Scheduled for the first week in May of each year
The remaining fluorescent lamps and fixtures are scheduled for replacement	Completed in 2020

**Note:** At this time, the City of Goshen WWTP has no known mercury bearing products onsite except the following:

- a. Sodium Hypochlorite - May contain low levels of mercury.
- b. Sodium Bisulfite - May contain low levels of mercury.
- c. Ferric Chloride- May contain low levels of mercury.
- d. I - Certified Thermometer for laboratory use.

The following actions are currently in place or are scheduled:

1. Suppliers are asked to provide low level or mercury free products during the bidding process every two years.
2. An alternative product will be sought. (ie. Ferric Chloride)
3. If no other product is available, the WWTP will research the need for the product and eliminate it if possible.
4. The product will be removed from the facility as soon as possible.
5. Waste materials or products that are no longer needed are disposed of in accordance with proper disposal procedures, including but not limited to returning them to the supplier or contracting with licensed disposal facilities.
6. The WWTP participates in "Beautify Goshen" week, which is scheduled for the first week in May of each year.
7. The fluorescent lamps and fixtures replacement program was completed in 2020.

**Part III A & B Pollutant Minimization Program Plan (PMPP) Planned Activities**

<b>Planned Activity</b>	<b>Goal</b>	<b>Measured Performance</b>	<b>Scheduled for Action</b>
Review of purchasing policies and procedures:  Chemical purchases including: <ul style="list-style-type: none"> <li>• Sodium Hypochlorite</li> <li>• Sodium Bisulfite</li> <li>• Ferric Chloride</li> </ul>	Reduce mercury in effluent		3 year cycle with chemical bids
Staff training	Education & awareness	Participation/Attendance	Ongoing. Part of annual on-line safety program/brochures.
Public education program	Education & awareness	Mercury along with Flushable wipes, Fats, Oils, and Grease are discussed during plant tours	This is ongoing with other articles such as fats, oils and grease, rags and other pretreatment issues.
Other activities Elimination of mercury switches, equipment, fluorescent lamps and fixtures.	Eliminate known mercury at the WWTP and lift stations	Participation	WWTP - Completed 2020 Mercury switches were removed from all lift stations prior to 2015. Lift station lighting replacement completed 2020.
Monitoring sewer collection system	Try to locate other sources of mercury from industrial parks, businesses and residential areas.	Participation  Mercury sampling and testing	Ongoing

**Part III C. Planned Activities**

<b>Sector</b>	<b>Planned Activity</b>	<b>Goal</b>	<b>Measure of Performance</b>	<b>Schedule for Action</b>
<b>Medical facilities, including:</b> -Hospitals -Clinics -Nursing homes -Veterinary facilities	Sample and test hospital lift station annually	Compliance	Mercury levels/Compliance	Ongoing
	The City developed and passed a Mercury Reduction Ordinance 4941 on March 12, 2018.	Compliance	Participation/Testing	Ongoing
	Site visits ( if applicable-Covid related)	Promote BMP		Ongoing
<b>Dental clinics:</b>	The City developed and passed a Mercury Reduction Ordinance 4941 on March 12, 2018	Compliance	Inspections	Ongoing
	One-Time Compliance Report for Dental Dischargers	Promote BMP	Compliance	Dental Clinics are in compliance
	Mercury testing	Evaluation of discharge	Mercury levels/ Compliance	Ongoing
	Survey(s)	Participation		Industrial surveys are filled out for all new industrial/ commercial customers
	Site visits ( if applicable-Covid related)	Compliance		
	Amalgam Separators	Compliance	Mercury levels/compliance Cleaning records	All Dental Clinics have Amalgam Separators installed.
<b>Public and private educational laboratories</b>	Mail surveys	Education & awareness		
	On-site visits (if applicable)	Promote BMP	Mercury along with Flushable wipes, Fats, Oils, and Grease are discussed during plant tours	Ongoing

**Part III C. Planned Activities -continued**

Sector	Planned Activity	Goal	Measure of Performance	Schedule for Action
<b>General Industry and all SIUs</b>	Mail Surveys	Education & awareness		
	On-site visits (if applicable-Covid related)	Promote BMP		
	Mercury Testing	Evaluation of discharge	Mercury levels/compliance	Ongoing
<b>Significant sources of residential and retail contributions of mercury, for example, the following:</b> -Heating, ventilation, and air conditioning contractors -Auto and appliance Repair -Veterinarians -Others specific to community served	Plant tours if applicable	Education & awareness	Mercury along with Flushable wipes, Fats, Oils, and Grease are discussed during plant tours	Ongoing
	Survey(s)	Participation		Industrial surveys are filled out for all new industrial/ commercial customers



**National Pollutant Discharge Elimination System  
 Fact Sheet for the  
 City of Goshen Wastewater Treatment Plant  
 Draft: April 2026  
 Final: TBD**

**Indiana Department of Environmental Management**  
 100 North Senate Avenue  
 Indianapolis, Indiana 46204  
 (317) 232-8603  
 Toll Free (800) 451-6027  
[www.idem.IN.gov](http://www.idem.IN.gov)

<b>Permittee:</b>	The Honorable Gina Leichty, Mayor City of Goshen 202 S. 5th Street, Suite 1 Goshen, Indiana 46528 574/533-9322 ginaleichty@goshencity.com
<b>Existing Permit Information:</b>	Permit Number: IN0025755 Expiration Date: June 30, 2026
<b>Facility Contact:</b>	Jim Kerezman, Superintendent 574/534-4003 wastewater@goshencity.com
<b>Facility Location:</b>	1000 West Wilden Avenue Goshen, Indiana Elkhart County
<b>Receiving Stream:</b>	Elkhart River
<b>GLI/Non-GLI:</b>	GLI
<b>Proposed Permit Action:</b>	Renewal
<b>Date Application Received:</b>	January 9, 2026
<b>Facility Category</b>	NPDES Major Municipal
<b>CSO Project Manager:</b>	Dave Tennis 317/234-9558 Dtennis@idem.IN.gov
<b>Permit Writer:</b>	Jay Hanko 317/233-0704 Jhanko@idem.IN.gov

# CITY OF GOSHEN OUTFALL 001 LOCATION

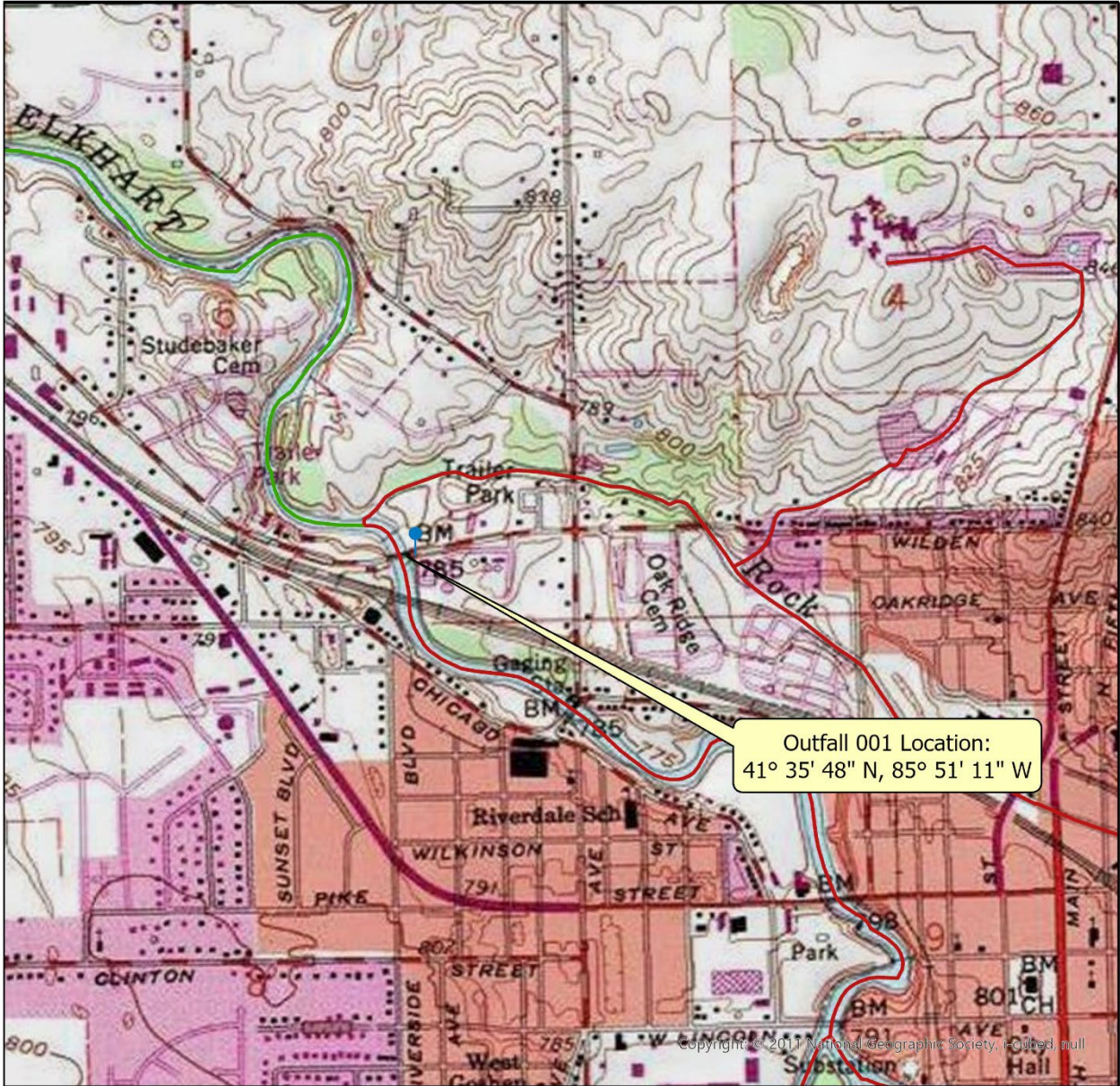

This map is intended to serve as an aid in graphic representation only. This information is not warranted for accuracy or other purposes.

**Mapped By:** J Hanko, Office of Water Quality  
**Date:** March 2026

**Map Projection:** UTM Zone 16 N

**Map Datum:** NAD83

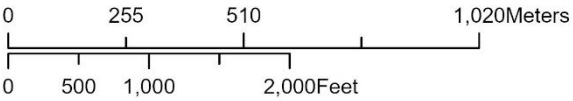

# Untitled Map

Goshen WWTP

Legend

Effluent 001 and Outfall 007

Outfalls 008 and 010

Outfall 009

Google Earth

Image © 2025 Airbus

700 ft

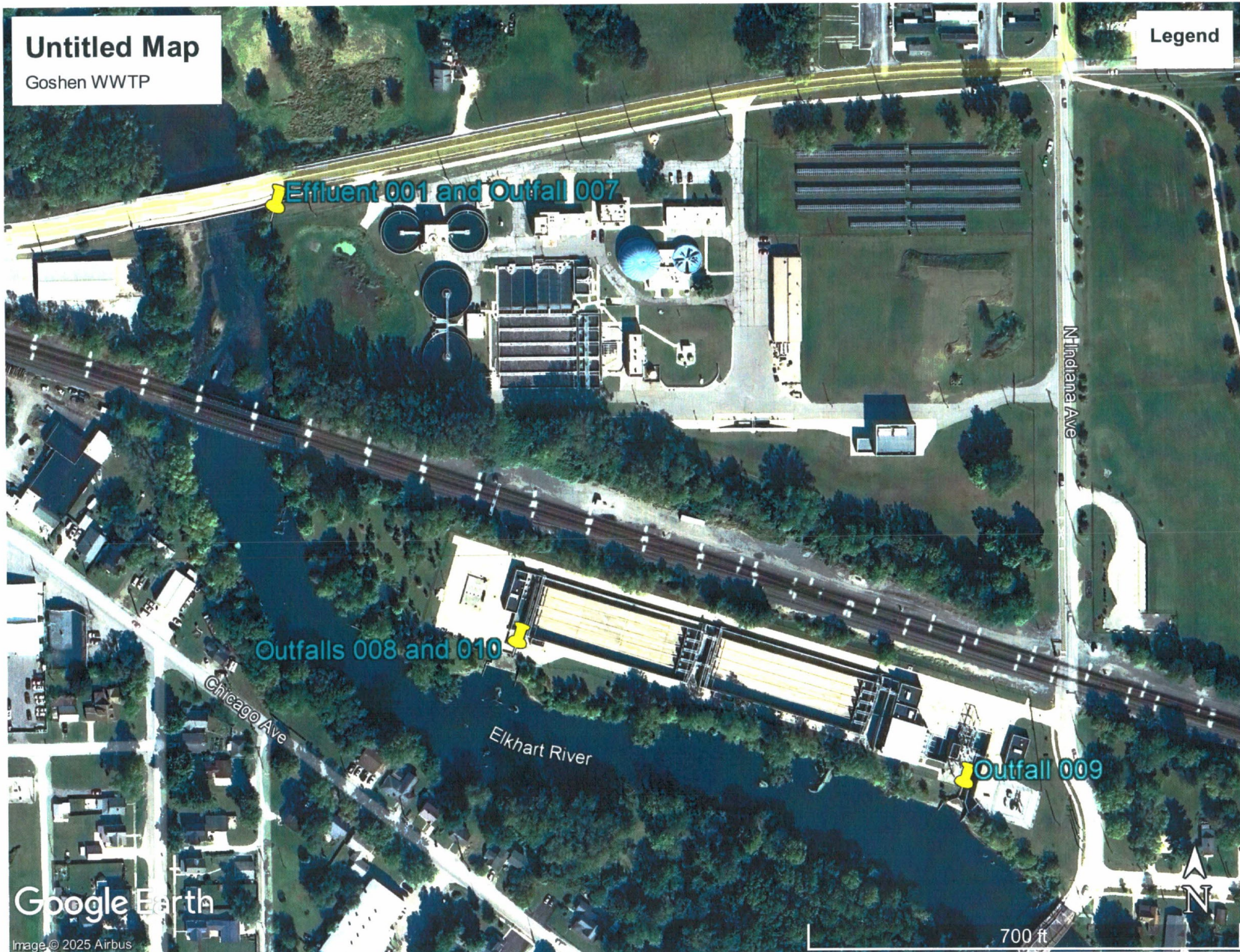

# FLOW SCHEMATIC FOR FACILITY

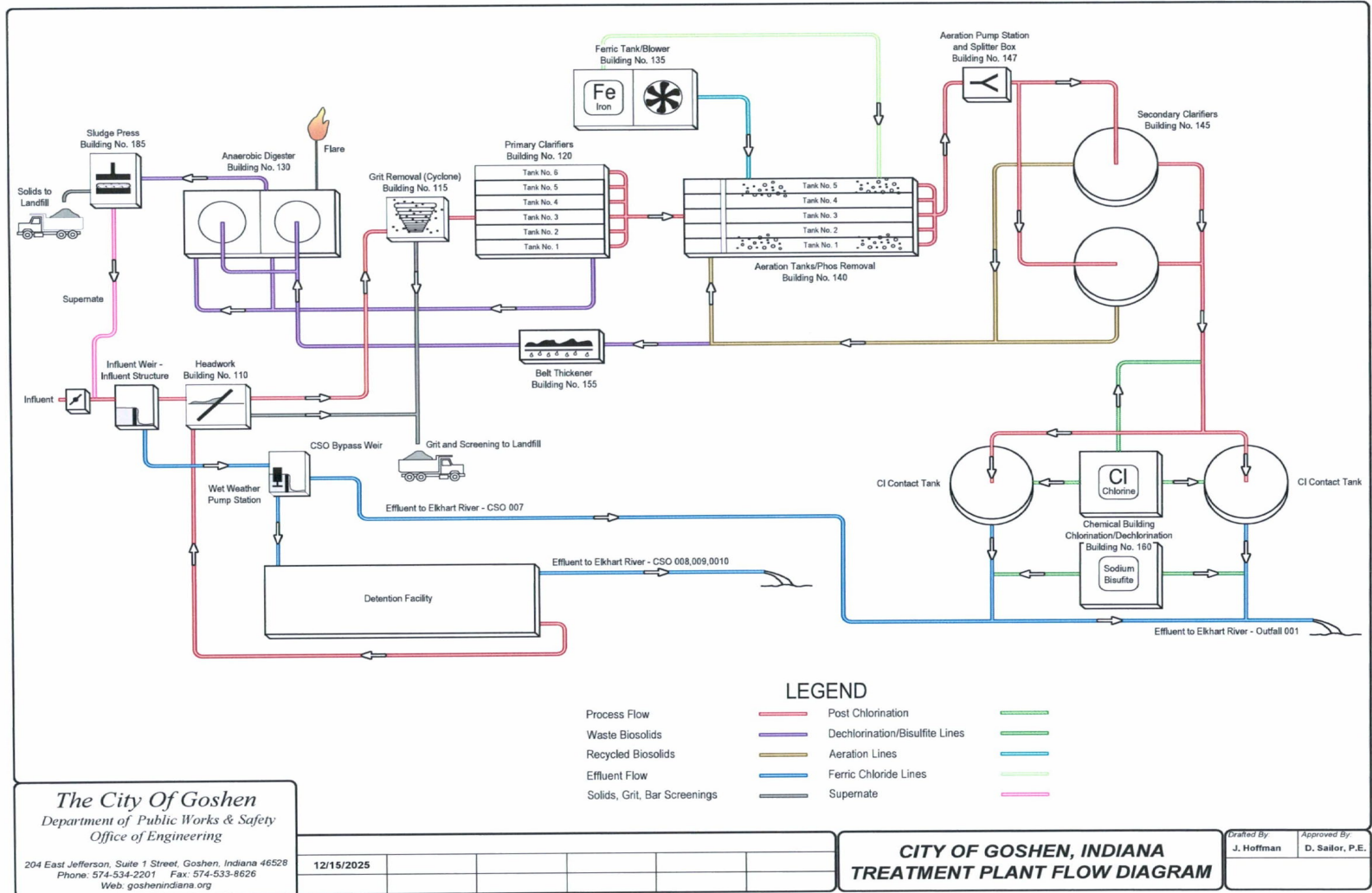

Outfall Location

Latitude: 41° 35' 48" N  
Longitude: 85° 51' 11" W

**Background**

This is the proposed renewal of the NPDES permit for the City of Goshen Wastewater Treatment Plant which was issued on April 15, 2026 and has an expiration date of June 30, 2026. The permittee submitted an application for renewal which was received on January 9, 2026.

The permittee currently operates a Class III, 5.0 MGD treatment facility consisting of two (2) bar screens, an influent flow meter, grit removal, six (6) primary clarifiers, five (5) activated sludge aeration tanks, two (2) secondary clarifiers, phosphorus removal, chlorination disinfection, an effluent flow meter, two (2) final clarifiers, and dechlorination. Sludge is treated by two (2) anaerobic digesters. Final sludge disposal via landfill.

Permit Revision & Construction History

The NPDES permit was modified October 13, 2023 to include the addition of a fifth aeration tank and other improvements to the wastewater treatment plant in association with SRF Project Permit Approval No. L-0583, which was issued by IDEM's Facility Construction and Engineering Support Section January 16, 2020. This permit modification did not alter the facilities design capacity or effluent limitations.

**Collection System**

The collection system is comprised of combined sanitary and storm sewers with four (4) Combined Sewer Overflow (CSO) locations. The CSO locations have been identified and are subject to the provisions in Attachment A of the permit.

<b>Outfall No.</b>	<b>Location</b>	<b>Receiving Stream</b>
007	WWTP CS Diversion Pump Station 41° 35' 48" N 85° 51' 11" W	Elkhart River
008	Wet Weather CS Detention Facility 41° 35' 40" N 85° 51' 06" W	Elkhart River
009	CS Detention Facility Headworks Overflow 41° 35' 38" N 85° 50' 57" W	Elkhart River
010	Overflow from CS Pump Station 41° 35' 40" N 85° 51' 06" W	Elkhart River

## CSO Statutory or Regulatory Basis for Permit Provisions

CSOs are point sources subject to NPDES permit requirements, including both technology-based and water quality-based requirements of the CWA and state law. Thus, the permit contains provisions IDEM deems necessary to meet water quality standards, as well as technology-based treatment requirements, operation and maintenance requirements, and best management practices. This permit is based on various provisions of state and federal law, including (1) Title 13 of the Indiana Code; (2) the water quality standards set forth in 327 IAC 2-1.5; (3) the NPDES rules set forth in 327 IAC 2 and 327 IAC 5, including 327 IAC 5-2-8 and 327 IAC 5-2-10; and (4) section 402(q) of the CWA (33 USC § 1342), which requires all permits or orders issued for discharges from municipal CSOs to conform with the provisions of EPA's National CSO Control Policy (58 Fed. Reg. 18688, April 19, 1994). EPA's CSO Policy contains provisions that, among other things, require permittees to develop and implement minimum technological and operational controls and long-term control plans to meet state water quality standards. The permit's penalty provisions are based in large part on IC 13-30. In addition to the regulatory provisions previously cited, the data collection and reporting requirements are based in part on 327 IAC 5-1-3, 327 IAC 5-2-13 and section 402(q) of the CWA. The long-term control plan provisions were included to ensure compliance with water quality standards.

## Explanation of Effluent Limitations and Conditions

The effluent limitations set forth in Part II of Attachment A are derived in part from the narrative water quality standards set forth in 327 IAC 2-1.5-8. The narrative standards are minimum standards that apply to all waters at all times and therefore are applicable to all discharges of pollutants. Because EPA has not issued national effluent limitation guidelines for this category of discharges, the technology-based BAT/BCT provisions are based on best professional judgment (BPJ) in addition to section 402(q) of the CWA. (CSO discharges are not subject to the secondary treatment requirements applicable to publicly owned treatment works because overflow points have been determined to not be part of the treatment plant. *Montgomery Environmental Coalition v. Costle*, 646 F.2d 568 (D.C. Cir. 1980).)

## CSO Long Term Control Plan Requirements

Goshen fully implemented their approved CSO Long Term Control Plan (LTCP) on February 27, 2012. The implemented plan is designed to store wet weather flows generated by the 10-year, 1-hour design storm for full treatment at the wastewater treatment plant. CSO discharge events will be periodically evaluated by IDEM to determine if such discharges are consistent with the CSO Level of Control (LOC) approved as part of the permittee's Long Term Control Plan (LTCP). Discharges determined by IDEM to not be consistent with the approved LOC may result in corrective actions and/or additional CSO controls being required to ensure future CSO discharges meet the requirements of the approved LTCP.

## **Spill Reporting Requirements**

Reporting requirements associated with the Spill Reporting, Containment, and Response requirements of 327 IAC 2-6.1 are included in Part II.B.2.c. and Part II.C.3. of the NPDES permit. Spills from the permitted facility meeting the definition of a spill under 327 IAC 2-6.1-4(15), the applicability requirements of 327 IAC 2-6.1-1, and the Reportable Spills requirements of 327 IAC 2-6.1-5 (other than those meeting an exclusion under 327 IAC 2-6.1-3 or the criteria outlined below) are subject to the Reporting Responsibilities of 327 IAC 2-6.1-7.

It should be noted that the reporting requirements of 327 IAC 2-6.1 do not apply to those discharges or exceedances that are under the jurisdiction of an applicable permit when the substance in question is covered by the permit and death or acute injury or illness to animals or humans does not occur. In order for a discharge or exceedance to be under the jurisdiction of this NPDES permit, the substance in question (a) must have been discharged in the normal course of operation from an outfall listed in this permit, and (b) must have been discharged from an outfall for which the permittee has authorization to discharge that substance.

## **Solids Disposal**

The permittee is required to dispose of its sludge in accordance with 329 IAC 10, 327 IAC 6.1, or 40 CFR Part 503. Solids at the facility are hauled offsite for disposal.

## **Receiving Stream**

The facility discharges to the Elkhart River via Outfall 001, which is located in the Goshen Dam Pond-Elkhart River Watershed, HUC-12: 040500011904 and Assessment Unit INJ01J4\_05. The receiving water is located within the Lake Michigan drainage basin. The receiving water has a seven day, ten year low flow ( $Q_{7,10}$ ) of 85 cubic feet per second (55 MGD) at the outfall location. This provides a dilution ratio of receiving stream flow to treated effluent of 11:1. There are no lakes or reservoirs within forty (40) miles downstream of the facility.

The receiving stream is designated for full body contact recreational use and shall be capable of supporting a well-balanced warm water aquatic community in accordance with 327 IAC 2-1.5-5.

The Assessment Unit is included in the 2024 303(d) list of impaired waterbodies in Indiana for *E. coli* (Category 5A). The *E. coli* limitations included in the permit address the *E. coli* impairment in the receiving stream. A Total Maximum Daily Load (TMDL) has not been developed to address these impairments.

## **Industrial Contributions**

The permittee accepts industrial flow from the following industries:

- Bearcat Corporation;
- Shilo;
- Dairy Farms of America (closed Goshen operations Dec. 31, 2024);
- Gleason Industrial Products (Madison St.);
- Gleason Industrial Products (Renolds St.);
- Lippert Components, Inc. Plant 45;
- Lippert Components, Inc. Plant 85;
- Viewrail Plant 6;

Based on the industrial flow received by the treatment facility, the permittee is required to operate its approved industrial pretreatment program approved on July 7, 1986. Provisions for the industrial pretreatment program are included in Part III of this permit renewal.

In addition, monitoring requirements and/or effluent limitations for cadmium, chromium, copper, cyanide, lead, mercury, nickel, selenium, silver, and zinc are being included in the permit renewal, as well as twice annual Whole Effluent Toxicity Testing (WETT).

## **Antidegradation**

Indiana's Antidegradation Standards and Implementation procedures are outlined in 327 IAC 2-1.3. The antidegradation standards established by 327 IAC 2-1.3-3 apply to all surface waters of the state. The permittee is prohibited from undertaking any deliberate action that would result in a new or increased discharge of a bioaccumulative chemical of concern (BCC) or a new or increased permit limit for a regulated pollutant that is not a BCC unless information is submitted to the commissioner demonstrating that the proposed new or increased discharge will not cause a significant lowering of water quality, or an antidegradation demonstration submitted and approved in accordance 327 IAC 2-1.3-5 and 2-1.3-6.

This permit includes new or increased permit limitations for copper, selenium and silver. In accordance with 327 IAC 2-1.3-1(b), the new or increased permit limitations are not subject to the Antidegradation Implementation Procedures in 327 IAC 2-1.3-5 and 2-1.3-6 as the new or increased permit limitations are not the result of a deliberate activity taken by the permittee.

## **Effluent Limitations and Rationale**

The effluent limitations proposed herein are based on Indiana Water Quality Standards, NPDES regulations, and a Wasteload Allocation (WLA) analyses performed by this Office's Permits Branch staff on September 3, 2004 and March 25, 2026. These limits are

in accordance with antibacksliding regulations specified in 327 IAC 5-2-10(a)(11)(A). Monitoring frequencies are based upon facility size and type.

IDEM has waived the 85% removal requirement for CBOD<sub>5</sub> and TSS under the provisions of 40 CFR 133.103(a). A limitation based on percent removal would be impractical due to this Office's CSO policy to maximize flow through the treatment facility.

The final effluent parameters to be limited and/or monitored include: Flow, Carbonaceous Biochemical Oxygen Demand (CBOD<sub>5</sub>), Total Suspended Solids (TSS), Ammonia-nitrogen (NH<sub>3</sub>-N), total phosphorus, total nitrogen, pH, Dissolved Oxygen (DO), Total Residual Chlorine (TRC), *Escherichia coli* (*E. coli*), WET, cadmium, chromium, copper, cyanide, lead, mercury, nickel, selenium, silver, and zinc.

### **Final Effluent Limitations**

The summer monitoring period runs from May 1 through November 30 of each year, and the winter monitoring period runs from December 1 through April 30 of each year. The disinfection season runs from April 1 through October 31 of each year.

The mass limits for CBOD<sub>5</sub>, TSS and ammonia-nitrogen have been calculated utilizing the peak design flow of 12.5 MGD. This is to facilitate the maximization of flow through the treatment facility in accordance with this Office's CSO policy.

### **Influent Monitoring**

The raw influent and the wastewater from intermediate unit treatment processes, as well as the final effluent shall be sampled and analyzed for the pollutants and operational parameters specified by the applicable Monthly Report of Operation Form, as appropriate, in accordance with 327 IAC 5-2-13 and Part I.B.2 of the permit. Except where the permit specifically states otherwise, the sample frequency for the raw influent and intermediate unit treatment process shall be at a minimum the same frequency as that for the final effluent. The measurement frequencies specified in each of the tables in Part I.A. are the minimum frequencies required by the permit.

### **Flow**

Flow is to be measured five (5) times weekly as a 24-hour total. Reporting of flow is required by 327 IAC 5-2-13.

### **CBOD<sub>5</sub>**

CBOD<sub>5</sub> is limited to 25 mg/l (2,608 lbs/day) as a monthly average and 40 mg/l (4,173 lbs/day) as a weekly average.

Monitoring is to be conducted five (5) times weekly by 24-hour composite sampling. The CBOD<sub>5</sub> concentration limitations included in this permit are water quality-based effluent limitations set in accordance with the WLA analysis performed by this Office's Permits Branch staff on September 3, 2004, and are the same as the concentration limitations found in the facility's previous permit.

### TSS

TSS is limited to 30 mg/l (3,129 lbs/day) as a monthly average and 45 mg/l (4,694 lbs/day) as a weekly average.

Monitoring is to be conducted five (5) times weekly by 24-hour composite sampling. The TSS concentration limitations included in this permit are calculated from the water-quality based effluent limitations for CBOD<sub>5</sub> set in accordance with the WLA analysis performed by this Office's Permits Branch staff on September 3, 2004, and are the same as the concentration limitations found in the facility's previous permit.

### Ammonia-nitrogen

Ammonia-nitrogen is limited to 3.1 mg/l (323 lbs/day) as a monthly average and 7.2 mg/l (751 lbs/day) as a daily maximum during the summer monitoring period. During the winter monitoring period, ammonia-nitrogen is limited to 5.8 mg/l (605 lbs/day) as a monthly average and 13.3 mg/l (1,387 lbs/day) as a daily maximum.

Monitoring is to be conducted five (5) times weekly by 24-hour composite sampling. The summer ammonia-nitrogen concentration limitations included in this permit are based on the permit issued December 31, 1990 in accordance with antibacksliding considerations with the provisions of 327 IAC 5-2-10(a)(11)(A). The winter ammonia-nitrogen concentration limitations included in this permit are based on the Wasteload Allocation (WLA) analysis performed by this Office's Permits Branch staff on September 3, 2004. The ammonia-nitrogen limitations are the same as the concentration limitations found in the facility's previous permit.

### Total Phosphorus

In accordance with 327 IAC 5-10-2(a) & (b), as the treatment facility discharges into receiving waters located within the Lake Michigan drainage basins, phosphorus removal facilities shall achieve a degree of reduction as prescribed in the sliding scale of phosphorus removal in Footnote [2] of the permit, or produce an effluent containing no more than 1.0 mg/l total phosphorus (P), whichever is more stringent. Monitoring is to be conducted five (5) times weekly by 24-hour composite sampling. These total phosphorus limitations are the same as the limitations found in the facility's previous permit.

## Total Nitrogen

Nutrient pollution is one of our Nation's top environmental challenges and considerations for addressing it continue to be a priority for IDEM. Nutrient pollution can lead to public health issues and impacts the economy and is of particular concern with regard to harmful algal blooms in the State of Indiana and harmful algal blooms and hypoxia problems in further downstream waters. Of particular concern in further downstream waters is the loadings of the nutrient nitrogen.

In response to the nutrient pollution concerns, the U.S. EPA released a memorandum on September 22, 2016 entitled "Renewed Call to Action to Reduce Nutrient Pollution and Support Incremental Actions to Protect Water Quality and Public Health", which can be found at the following web address: <https://www.epa.gov/sites/production/files/2016-09/documents/renewed-call-nutrient-memo-2016.pdf>. EPA recommends all major sanitary dischargers begin monitoring for total nitrogen. To begin the process of total nitrogen data collection, IDEM is proposing that all major sanitary dischargers with average design flow ratings of 1.0 MGD or greater begin monitoring for total nitrogen.

The permit requires that total nitrogen be monitored and report at a minimum of one (1) time monthly. Both the concentration and associated loading values must be reported. Total nitrogen shall be determined by testing for Total Kjeldahl Nitrogen (TKN) and Nitrate + Nitrite Nitrogen and reporting the sum of the TKN and Nitrate + Nitrite results (reported as N). Nitrate + Nitrite can be analyzed together or separately.

## pH

The pH limitations have been based on 40 CFR 133.102 which is cross-referenced in 327 IAC 5-5-3. To ensure conditions necessary for the maintenance of a well-balanced aquatic community, the pH of the final effluent must be between 6.0 and 9.0 standard units in accordance with provisions in 327 IAC 2-1-6(b)(2).

pH must be measured five (5) times weekly by grab sampling. These pH limitations are the same as the limitations found in the facility's previous permit.

## Dissolved Oxygen

Dissolved oxygen shall not fall below 4.0 mg/l as a daily minimum average.

This dissolved oxygen limitation is a water quality-based effluent limitation set in accordance with the WLA analysis performed by this Office's Permits Branch staff on September 3, 2004, and is the same as the concentration limitation found in the facility's previous permit.

Dissolved oxygen measurements must be based on the average of three (3) grab samples taken within a 24-hr. period. This monitoring is to be conducted five (5) times weekly.

## Total Residual Chlorine

In accordance with Indiana Water Quality Standards, the final effluent limits (end-of-pipe) for TRC are 0.02 mg/l monthly average and 0.04 mg/l daily maximum. The monthly average Water Quality-Based Effluent Limit (WQBEL) for total residual chlorine is less than the limit of quantitation (LOQ), 0.06 mg/l. Compliance with this permit will be demonstrated if the monthly average effluent level is less than or equal to the monthly average WQBEL. Daily effluent values that are less than the LOQ, used to determine the monthly average effluent levels less than the LOQ, may be assigned a value of zero (0), unless, after considering the number of monitoring results that are greater than the limit of detection (LOD), and applying appropriate statistical techniques, a value other than zero (0) is warranted.

The daily maximum WQBEL for total residual chlorine is greater than or equal to the LOD value, but less than the LOQ value specified in the permit. Compliance with this permit will be demonstrated if the observed daily effluent concentrations are less than the LOQ. For daily maximum mass limitations based on WQBEL's less than the LOQ, compliance with the daily maximum mass value is based on the LOQ value. Compliance with the daily maximum mass value will be demonstrated if the calculated mass value is less than 4.2 lbs/day. These total residual chlorine limitations are the same as the limitations found in the facility's previous permit.

## *E. coli*

The *E. coli* limitations and monitoring requirements apply from April 1 through October 31, annually. *E. coli* is limited to 125 count/100 ml as a monthly average, and 235 count/100 ml as a daily maximum. The monthly average *E. coli* value shall be calculated as a geometric mean. This monitoring is to be conducted five (5) times weekly by grab sampling. These *E. coli* limitations are set in accordance with regulations specified in 327 IAC 5-10-6.

## Mercury

The NPDES permit requires that mercury sampling be conducted bi-monthly (every other month) for the term of the permit (influent and effluent). The mercury WQBELs are based on the wildlife criterion in 327 IAC 2-1.5-8(b)(6), Table 8-4. In accordance with 327 IAC 5-2-11.4(b)(1) the criteria for mercury are applied without the utilization of a mixing zone. Mercury is limited to 1.3 ng/l (0.000054 lbs/day) as a monthly average and 3.2 ng/l (0.00013 lbs/day) as a daily maximum.

A review of the permittee's effluent mercury data revealed that mercury limitations are required to be retained in the permit renewal. Therefore, in accordance with 327 IAC 5-2-11.5(b), Water Quality-Based Effluent Limitations (WQBELs) for mercury are being retained in the permit. In anticipation of the mercury WQBELs, the permittee submitted a Streamlined Mercury Variance (SMV) renewal application for mercury.

### Streamlined Mercury Variance (SMV) Renewal

The permittee applied for a Streamlined Mercury Variance (SMV) on November 9, 2010. The SMV was initially incorporated into the NPDES Permit with a permit renewal that became effective on July 1, 2011. The permittee submitted a SMV renewal application on January 9, 2026. This SMV renewal application was deemed complete on January 9, 2026 after the completion of the Pollutant Minimization Program Plan (PMPP) public notice period. The SMV renewal has been incorporated into this permit renewal.

The SMV establishes a streamlined process for obtaining a variance from a water quality criterion used to establish a WQBEL for mercury in an NPDES permit. The goal of the SMV is to reduce the effluent levels of mercury towards, and achieve as soon as practicable, compliance with the mercury WQBELs through implementation of a pollutant minimization program plan (PMPP). The SMV renewal will remain in effect until the permit expires under IC 13-14-8-9. Pursuant to IC 13-14-8-9(c), when the SMV renewal is incorporated into a permit extended under IC 13-15-3-6 (administratively extended), the renewal will remain in effect until the permit expires.

### Mercury Interim Discharge Limit

The permit includes an interim discharge limit for mercury of 2.23 ng/l. Compliance with the interim discharge limit will be achieved when the average of the measured effluent daily values over the rolling twelve-month period is less than the interim limit.

The interim discharge limit was developed in accordance with 327 IAC 5-3.5-7 and with 327 IAC 5-3.5-8. Specifically, the interim discharge limit shall be based upon available, valid, and representative data of the effluent mercury levels collected and analyzed over the most recent two (2) year period from the WWTP. This Office received a complete SMV renewal application on January 9, 2026. Therefore, mercury data two (2) years prior to January 9, 2026 were utilized in determining the mercury interim discharge limit (see Attachment A of this Fact Sheet to view the City of Goshen's SMV dataset).

### Pollutant Minimization Program Plan (PMPP)

PMPP requirements are outlined in 327 IAC 5-3.5-9 and are included in Attachment B of the NPDES permit in accordance with 327 IAC 5-3.5-6. The PMPP focuses on pollution prevention and source control measures to achieve mercury reduction in the effluent. The PMPP was public noticed prior to submittal to IDEM in accordance with 327 IAC 5-3.5-9(c). No comments were received during the public notice period. The goal of the PMPP is to reduce the effluent levels of mercury towards, and achieve as soon as practicable, compliance with the mercury WQBELs established for the permitted facility.

## SMV Annual Reports

The permittee is required to submit annual reports to IDEM by **July 1** of each year in which the SMV is in effect. The annual report must describe the SMV applicant's progress toward fulfilling each PMPP requirement, the results of all mercury monitoring within the previous year, and the steps taken to implement the planned activities outlined under the PMPP.

## Metals/Non-conventional Pollutants

The City of Goshen's current NPDES permit includes effluent limitations or monitoring requirements for cadmium, chromium, copper, cyanide, lead, nickel, silver, zinc, and mercury. Additionally, the city provided valid monitoring data for arsenic, molybdenum, and selenium with the NPDES permit application. The monitoring data for these metals was evaluated as part of the NPDES permit renewal. Mercury has been addressed in the previous section of this Fact Sheet and will not be included any further in this discussion.

The evaluation of the monitoring data revealed that the discharge from the wastewater treatment plant did not show potential to exceed the water quality criterion for cadmium, chromium, lead, nickel, arsenic, molybdenum, and cyanide within the receiving waters. Cadmium, chromium, lead, nickel, and cyanide quarterly monitoring requirements have been included in the NPDES permit renewal due to industrial contributions for these parameters. Arsenic and molybdenum have not been included based on no known significant industrial contributions.

Reasonable Potential Evaluations (RPE) were performed in conjunction with the Wasteload Allocation Analysis performed by this Office's Permits Branch staff on March 25, 2026 for copper, selenium, silver, and zinc. In reviewing the RPE, the Projected Effluent Quality (PEQ) for zinc is less than the Projected Effluent Limitations (PEL). However, due to the industrial contributors to the Goshen collection system, the quarterly monitoring requirements for zinc are being retained.

The RPE performed by this Office's Permits Branch staff on March 25, 2026 revealed that the PEQ for copper, selenium, and silver was greater than the PELs. Therefore, effluent limitations for copper, selenium, and silver are being included in this permit.

Copper is limited to 0.041 mg/l (1.7 lbs/day) as a monthly average and 0.082 mg/l (3.4 lbs/day) as a daily maximum. Selenium is limited to 0.0031 mg/l (0.13 lbs/day) as a monthly average and 0.0075 mg/l (0.31 lbs/day) as a daily maximum. Silver is limited to 0.00018 mg/l (0.0074 lbs/day) as a monthly average and 0.00036 mg/l (0.015 lbs/day) as a daily maximum. Monitoring for these parameters is to be conducted weekly by 24-Hr. composite sampling.

As the final effluent limitations for copper, selenium, and silver are more stringent than the requirements of the previous permit, a 36-month schedule of compliance for is included in

Part I.E. of the permit. The permittee is required to monitor copper, selenium, and silver during the interim period as noted in Table 4 of the permit.

Additionally, quarterly effluent monitoring for cadmium, chromium, cyanide, lead, nickel, and zinc is required as these pollutants have been identified in the wastestreams of the significant industrial contributors to the Goshen WWTP.

In addition to effluent monitoring and limitations, the permittee is required to monitor the influent wastestream for all parameters in accordance with Table 5 of Part I.A.4. of the permit.

### Whole Effluent Toxicity Testing

Indiana's regulations for the Great Lakes system include narrative criteria with numeric interpretations for acute (2-1.5-8(b)(1)(E)(ii)) and chronic (2-1.5-8(b)(2)(A)(iv)) whole effluent toxicity (WET) and a procedure for conducting reasonable potential for WET (5-2-11.5(c)(1)). The U.S. EPA did not approve the reasonable potential procedure for WET so Indiana is now required under 40 CFR Part 132.6(c) to use the reasonable potential procedure in Paragraphs C.1 and D of Procedure 6 in Appendix F of 40 CFR Part 132. IDEM used this procedure in conducting the reasonable potential analysis for WET. The analysis is included in the Wasteload Allocation Analysis conducted by this Office's Permits Branch staff on March 25, 2026.

The results of the reasonable potential analysis for WET show that the discharge from Outfall 001 has a reasonable potential to exceed the numeric interpretation of the narrative criterion for acute and chronic WET. Therefore, WQBELs are required for WET.

Once a determination is made that WQBELs are required for WET, the WQBELs are established in accordance with 327 IAC 5-2-11.6(d). This provision allows a case-by-case determination of whether to establish a WQBEL for only acute or chronic WET, or WQBELs for both acute and chronic WET. The chronic WQBEL was established as a monthly average limit and set equal to the chronic wasteload allocation in accordance with 327 5-2-11.6(d)(1)(E). The acute WQBEL was established as a daily maximum limit and set equal to the acute wasteload allocation in accordance with 327 5-2-11.6(d)(1)(E). The monthly average WQBEL for WET is **3.8** chronic toxicity units (TUc) and chronic WET testing is required twice annually. The daily maximum WQBEL for WET is **1.0** acute toxicity units (TUa) and acute WET testing is required twice annually.

### Backsliding

None of the concentration limits included in this permit conflict with antibacksliding regulations found in 327 IAC 5-2-10(a)(11)(A), therefore, backsliding is not an issue.

## **Reopening Clauses**

Nine (9) reopening clauses have been incorporated into the permit in Part I.C and Attachment A. One clause is to incorporate effluent limits from any further wasteload allocations performed; a second clause is to allow for changes in the sludge disposal standards; a third clause is to incorporate any applicable effluent limitation or standard issued or approved under section 301(b)(2)(C), (D) and (E), 304(b)(2), and 307(a)(2) of the Clean Water Act; a fourth clause is to incorporate monitoring requirements and effluent limitations for cadmium, chromium, cyanide, lead, nickel, and zinc if the Department of Environmental Management determines that such monitoring requirements and effluent limitations are needed to assure that State Water Quality standards are met in the receiving streams; a fifth clause to include a case-specific Method Detection Level (MDL); a sixth clause is to incorporate additional requirements or limitations for specific toxicants if the required additional analyses in Part I.A. indicate that such additional requirements and/or limitations are necessary; a seventh clause is to incorporate changes to the mercury monitoring requirements; an eighth clause is to address changes in the EPA National CSO Policy or state or federal law; and a ninth clause is to incorporate applicable provisions of IC 13-18.

## **Compliance Status**

The permittee has no enforcement actions at the time of this permit preparation.

## **Expiration Date**

A five-year NPDES permit is proposed.

## **Permit Processing/Public Comment**

Pursuant to IC 13-15-5-1, IDEM will publish the draft permit document online at <https://www.in.gov/idem/public-notices/>. Additional information on public participation can be found in the "Citizens' Guide to IDEM", available at <https://www.in.gov/idem/resources/citizens-guide-to-idem/>. A 30-day comment period is available to solicit input from interested parties, including the public.

**ATTACHMENT A**  
**Effluent Data Collected by the City of Goshen WWTP for the**  
**Two (2) Year Period Prior to SMV Renewal Application being considered complete**  
**Outfall 001 (IN0025755)**

**Date SMV Application Deemed Complete: January 9, 2026**

Sample Date	Total Mercury Normal Sample (ng/L)	Total Mercury Duplicate Sample (ng/L)	Total Mercury Daily Average (ng/L)
2/26/2024	55.20		55.20*
4/25/2024	1.06		1.06
6/20/2024	1.01		1.01
8/20/2024	0.73		0.73
10/22/2024	0.73		0.73
12/12/2024	0.74		0.74
2/17/2025	1.43		1.43
4/23/2025	2.23		2.23
6/11/2025	0.585		0.585
8/21/2025	0.95		0.95
10/16/2025	0.68		0.68
12/17/2025	0.6		0.55
<b>Number</b>			<b>12</b>
<b>Max</b>			<b>55.20*</b>
<b>SMV Limit</b>			<b>2.23</b>

\*Outlier for the purpose of this analysis.