

## INDEX

| SHEET NO. | SUBJECT  | SUPERSEDES       |
|-----------|--|------------------|
| 1         | Pavement Corrugations, Index and General Notes                   | 606-SHCG-01      |
| 2         | Shoulder Corrugations, HMA                                       | 606-SHCG-02      |
| 3         | Shoulder Corrugations, PCCP                                      | 606-SHCG-03      |
| 4         | Shoulder Corrugation Limits: Entrance and Exit Ramps             | 606-SHCG-04      |
| 5         | Shoulder Corrugation Limits for Approaches and Median Crossovers | 606-SHCG-05 & 06 |
| 6         | Centerline Rumble Stripes  | 606-SHCG-07      |
| 7         | Edgeline Rumble Stripes  | 606-SHCG-08      |
| 8         | Shoulder Rumble Strips (Undivided Highway)                       | 606-SHCG-10      |
| 9         | Rumble Strip Limits: Intersection, Drive, Bridge, or Railroad    | 606-SHCG-09 & 11 |

### GENERAL NOTES:

1. Shoulder corrugations use a conventional milled pavement corrugation pattern.
2. Rumble strips and rumble stripes use a sinusoidal milled pavement corrugation pattern.

INDIANA DEPARTMENT OF TRANSPORTATION

PAVEMENT CORRUGATIONS,  
INDEX AND GENERAL NOTES

EFFECTIVE FOR LETTINGS ON OR AFTER 03-01-23

RECURRING PLAN DETAIL NO. 606-T-234d

Sheet 01 of 09

**NOTES:**

1. Continuous corrugation installation shall be used on interstates and intermittent installation shall be used on all other facilities.
2. Refer to Sheet 3 for corrugation instructions for HMA shoulders adjacent to a widened PCCP outside lane.

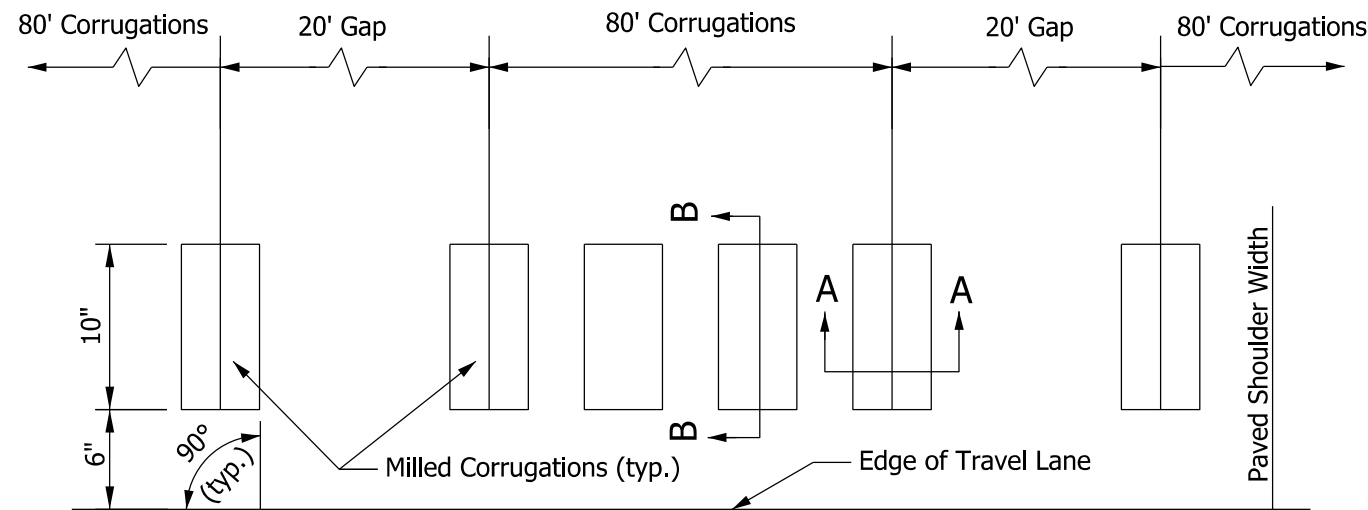

**INTERMITTENT INSTALLATION  
PLAN VIEW**

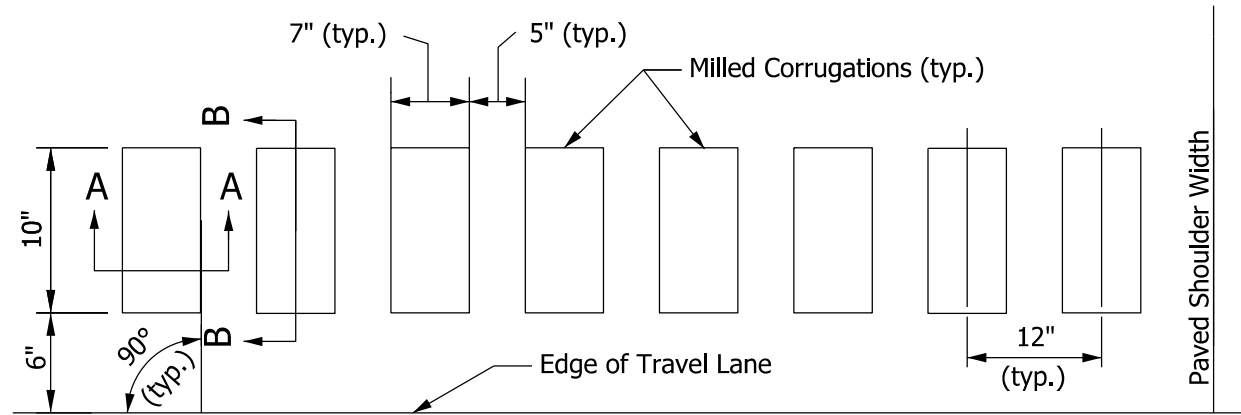
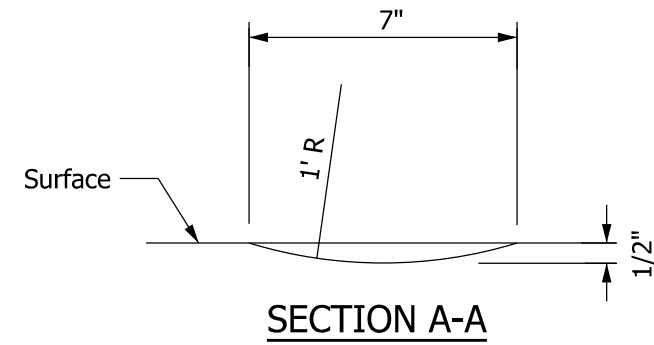

**CONTINUOUS INSTALLATION  
PLAN VIEW**

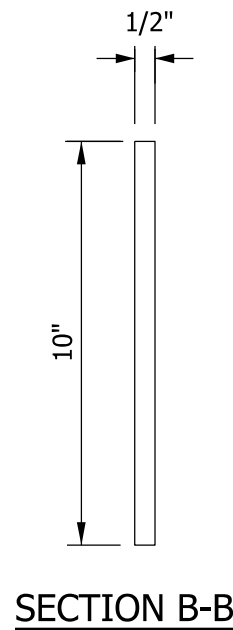

|   |            |
|---|------------|
| INDIANA DEPARTMENT OF TRANSPORTATION        |            |
| SHOULDER CORRUGATIONS, HMA                  |            |
| EFFECTIVE FOR LETTINGS ON OR AFTER 03-01-23 |            |
| RECURRING PLAN DETAIL NO.                   | 606-T-234d |
| Sheet 02 of 09                              |            |

D-1 Contraction Joint Spacing (Typical Panel)

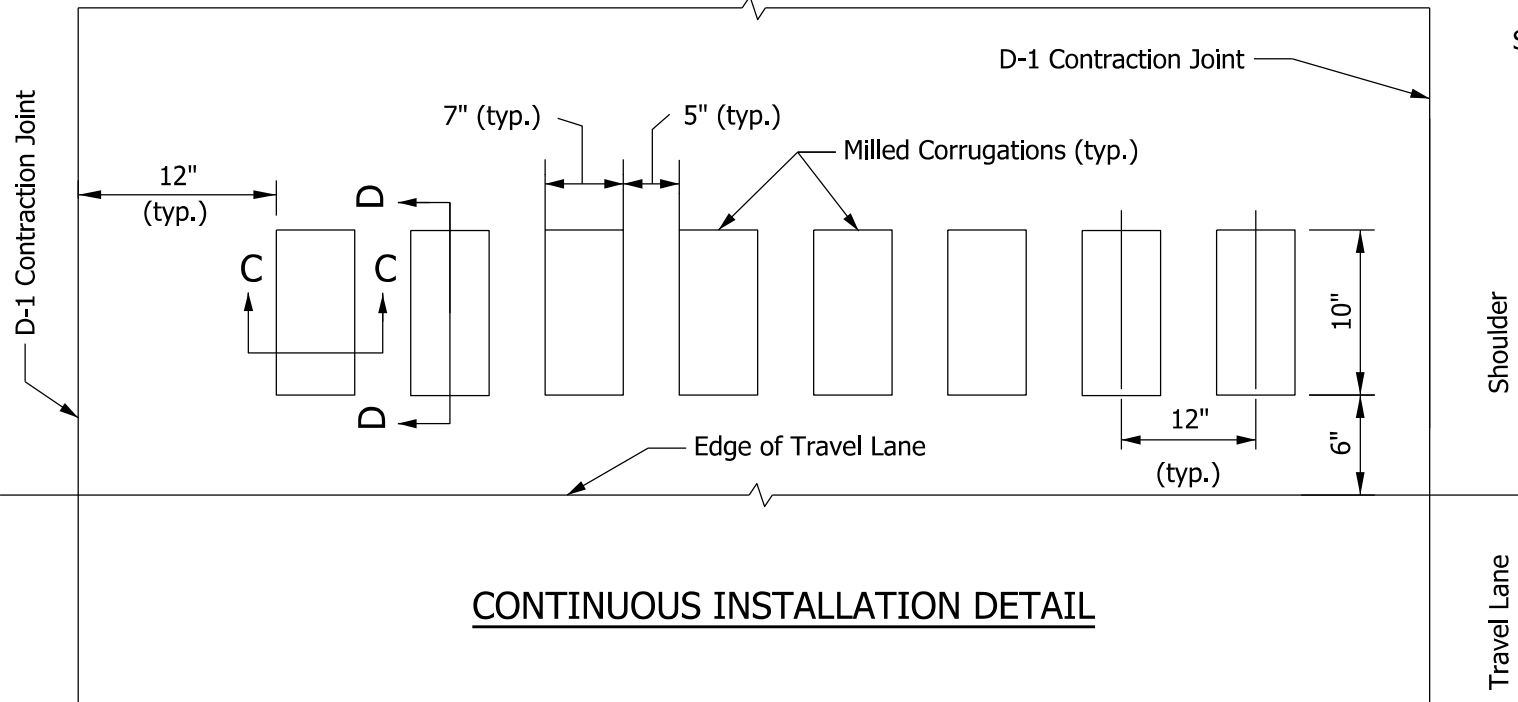

CONTINUOUS INSTALLATION DETAIL

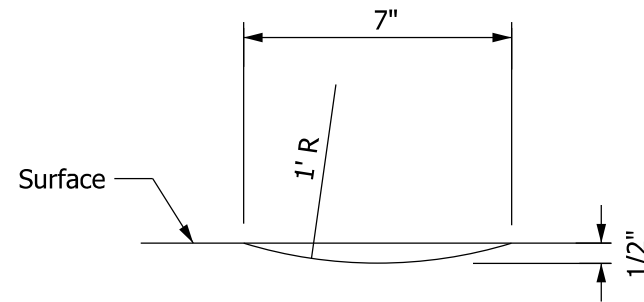

SECTION C-C

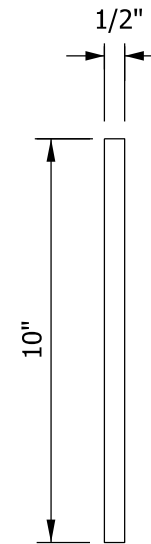

SECTION D-D

**NOTES:**

1. Continuous corrugations shall be required on every PCCP shoulder panel on interstates. Intermittent corrugations shall be required for all other facilities.
2. On facilities with a widened outside PCCP lane, the corrugations shall be installed on the portion of the PCCP located outside the edge of travel lane and in accordance with this sheet.

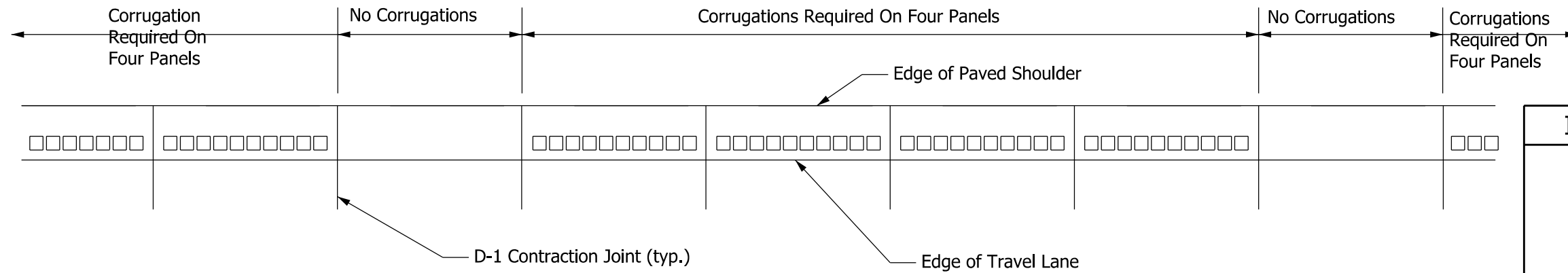

INTERMITTENT INSTALLATION DETAIL

INDIANA DEPARTMENT OF TRANSPORTATION

SHOULDER CORRUGATIONS, PCCP

EFFECTIVE FOR LETTINGS ON OR AFTER 03-01-23

RECURRING PLAN DETAIL NO. 606-T-234d

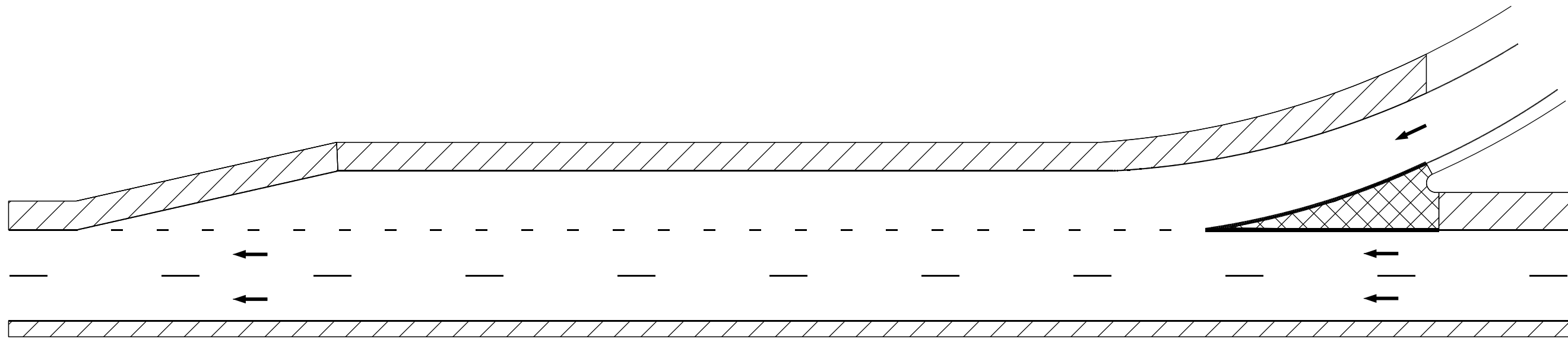

ENTRANCE RAMP

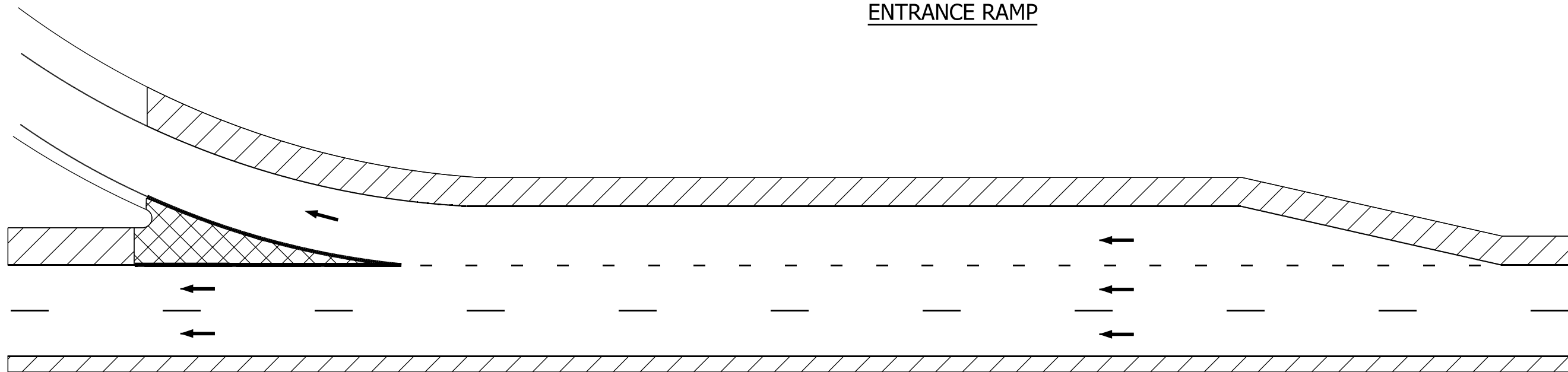

EXIT RAMP

LEGEND

 Gore Area (No Corrugations)

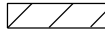
 Shoulder Corrugations

 Direction of Traffic

INDIANA DEPARTMENT OF TRANSPORTATION

SHOULDER CORRUGATION LIMITS:  
ENTRANCE AND EXIT RAMPS

EFFECTIVE FOR LETTINGS ON OR AFTER 03-01-23

RECURRING PLAN DETAIL NO. 606-T-234d

Sheet 04 of 09

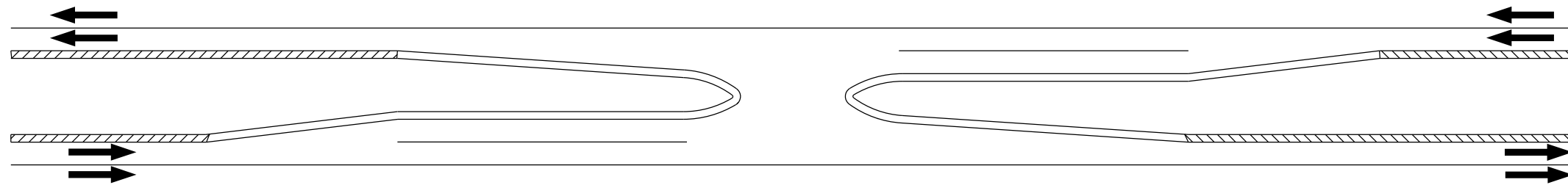

MEDIAN CROSSOVER / LEFT TURN LANE

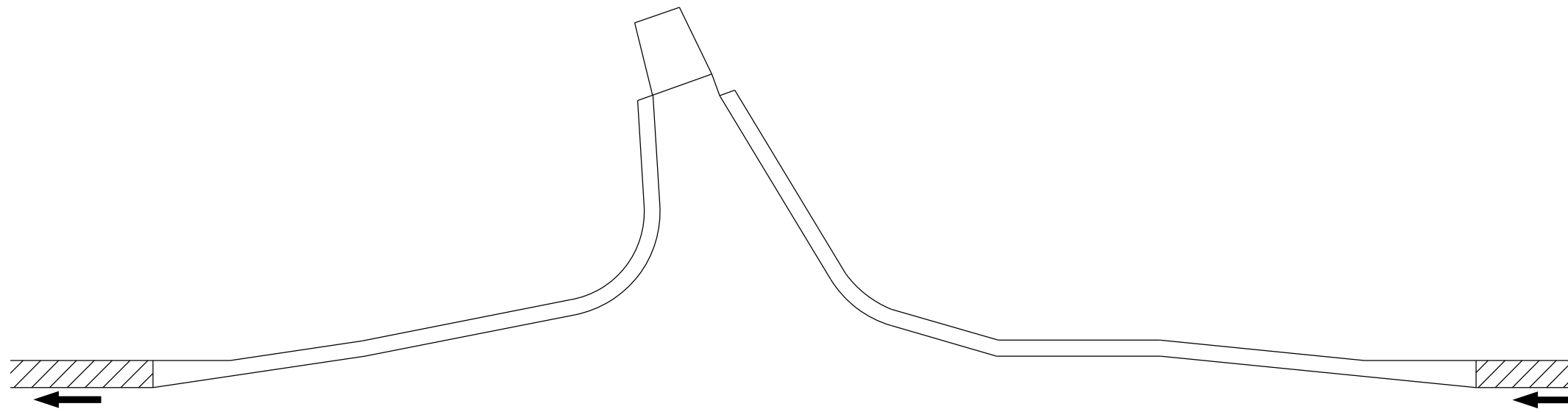

APPROACH WITH RIGHT TURN LANE

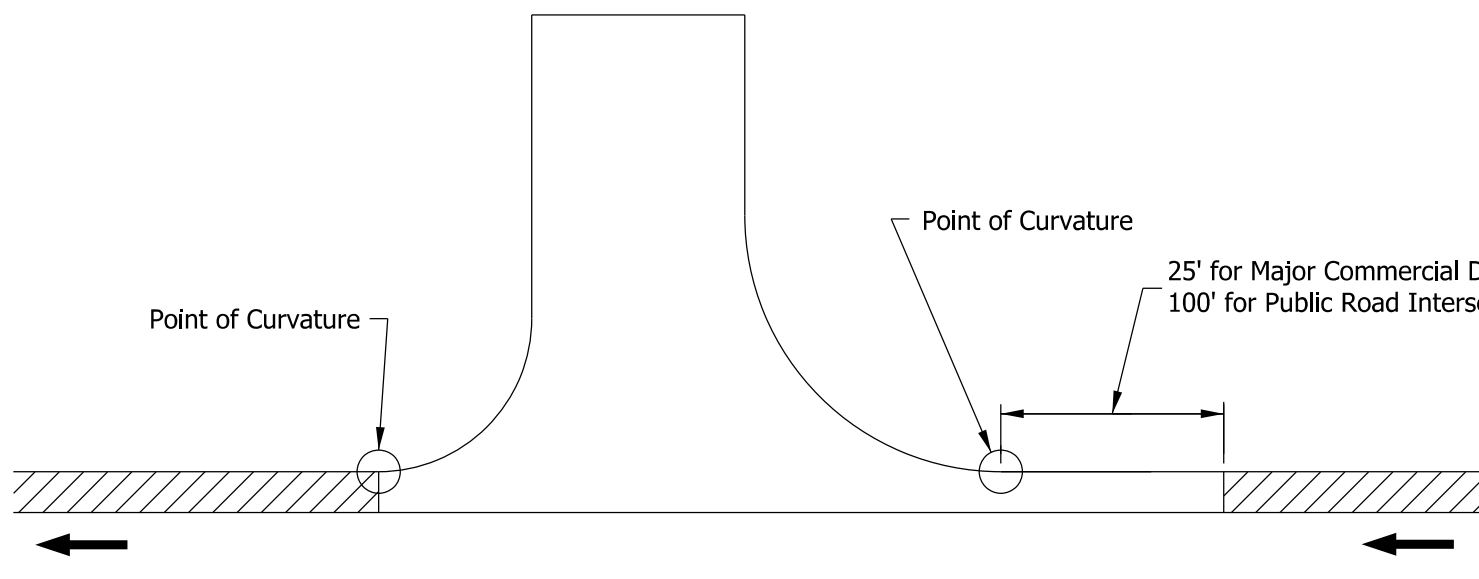

APPROACH WITHOUT RIGHT TURN LANE

LEGEND

 Shoulder Corrugations

 Direction of Traffic

INDIANA DEPARTMENT OF TRANSPORTATION

SHOULDER CORRUGATION LIMITS  
FOR APPROACHES AND MEDIAN CROSSOVERS

EFFECTIVE FOR LETTINGS ON OR AFTER 03-01-23

RECURRING PLAN DETAIL NO. 606-T-234d

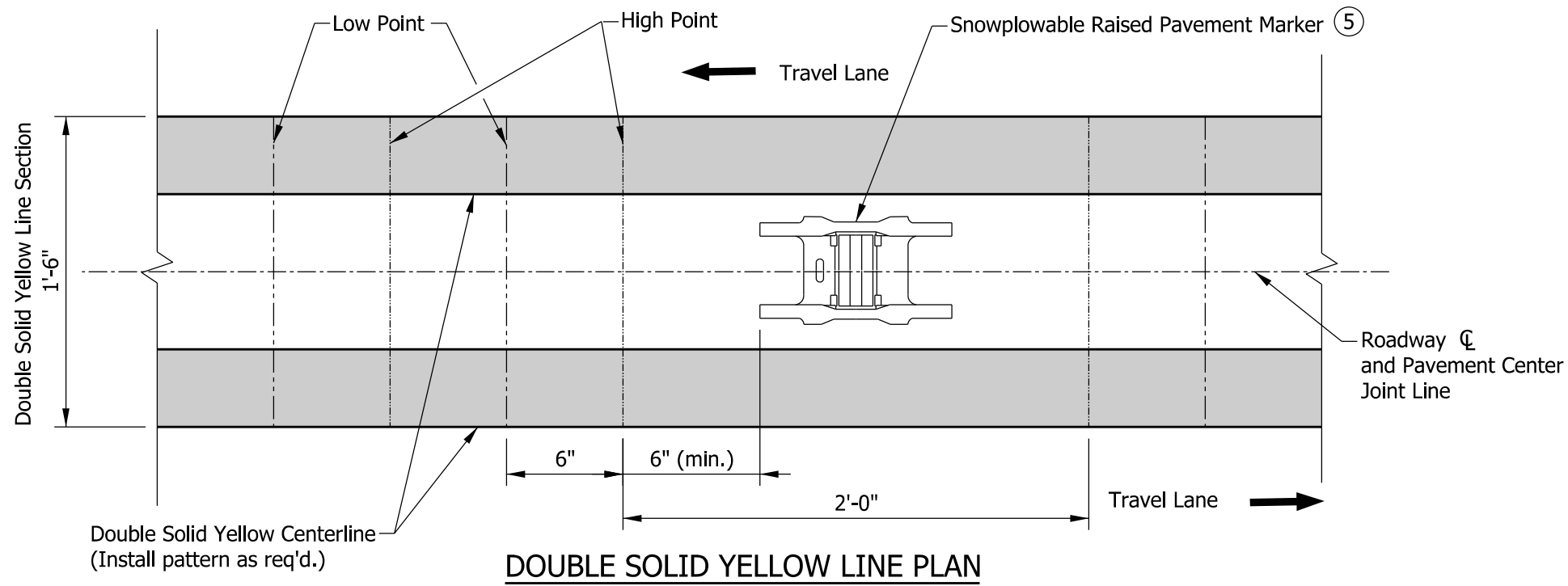

**NOTES:**

1. Rumble stripe shall be centered about the roadway centerline.
2. The liquid asphalt sealant width shall be a minimum of 24 in. centered on the pavement center joint line, and shall be extended, where directed, to provide coverage beyond the edge of the corrugation.
3. The corrugations shall be no closer than 6 in. to a casting or a concrete pavement transverse joint.
4. See Standard Drawing E 808-MKRM series for spacing of snowplowable raised pavement markers.
- 5 On PCCP, the double solid yellow line shall be treated as a restricted area for snowplowable raised pavement markers and handled in accordance with 808.11(b).

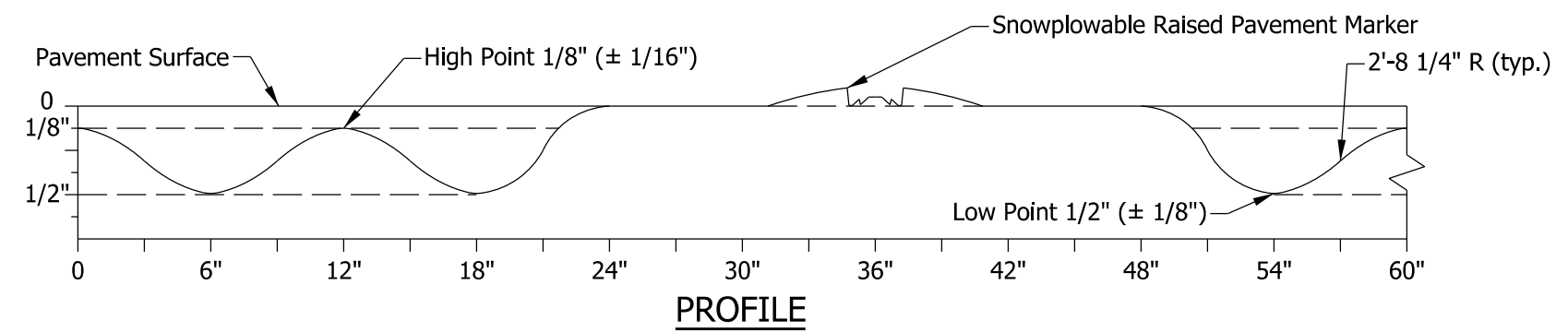
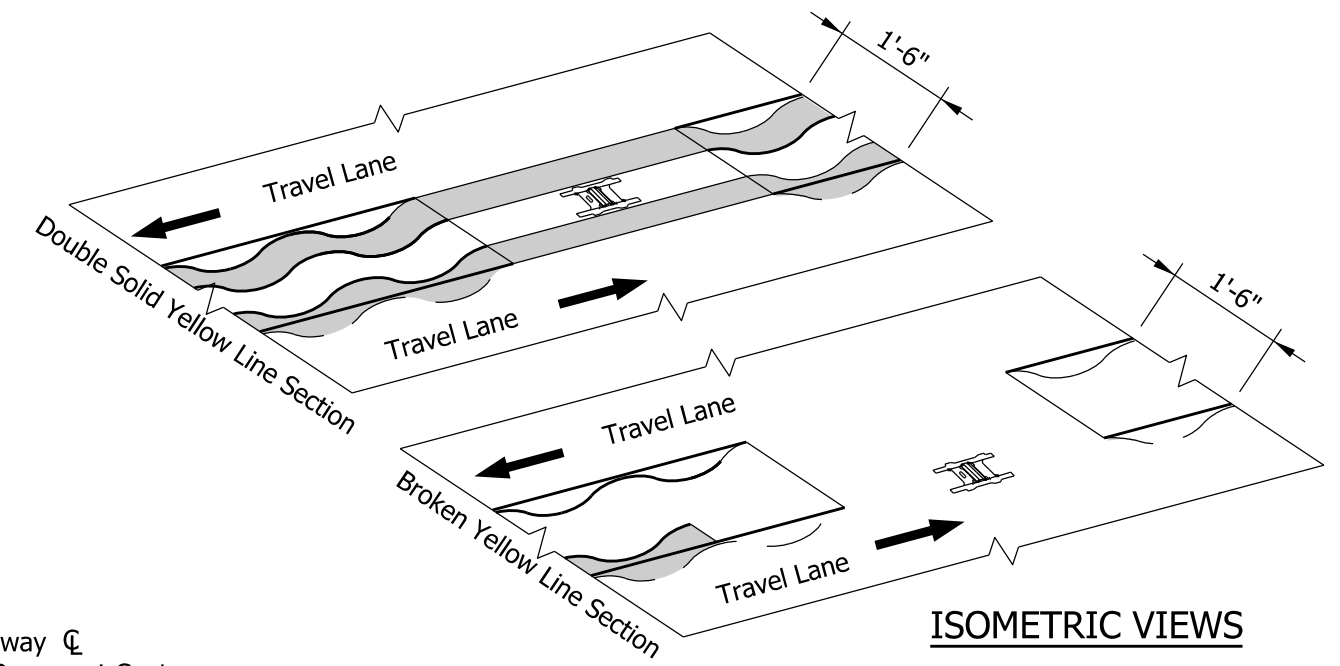
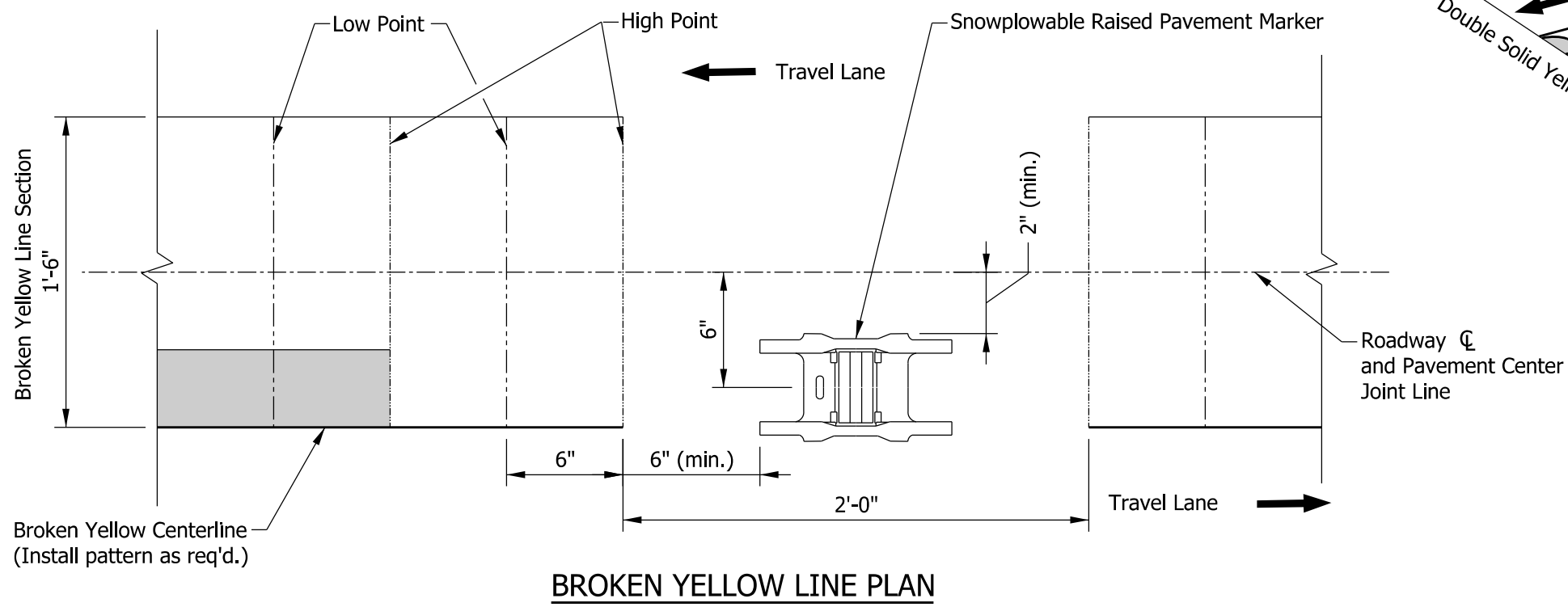

INDIANA DEPARTMENT OF TRANSPORTATION

CENTERLINE RUMBLE STRIPES

EFFECTIVE FOR LETTINGS ON OR AFTER 03-01-23

RECURRING PLAN DETAIL NO. 606-T-234d

Sheet 06 of 09

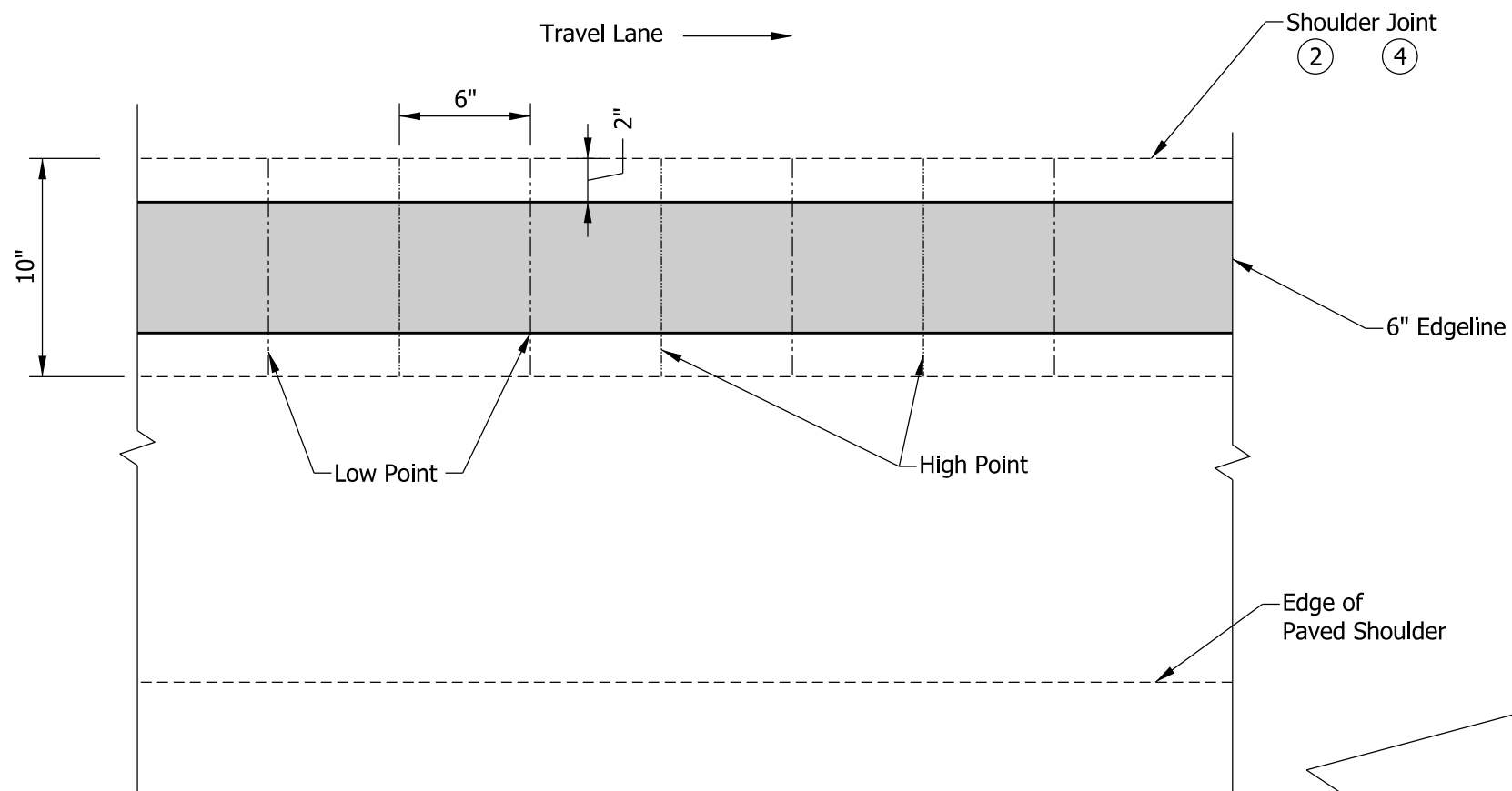

PLAN

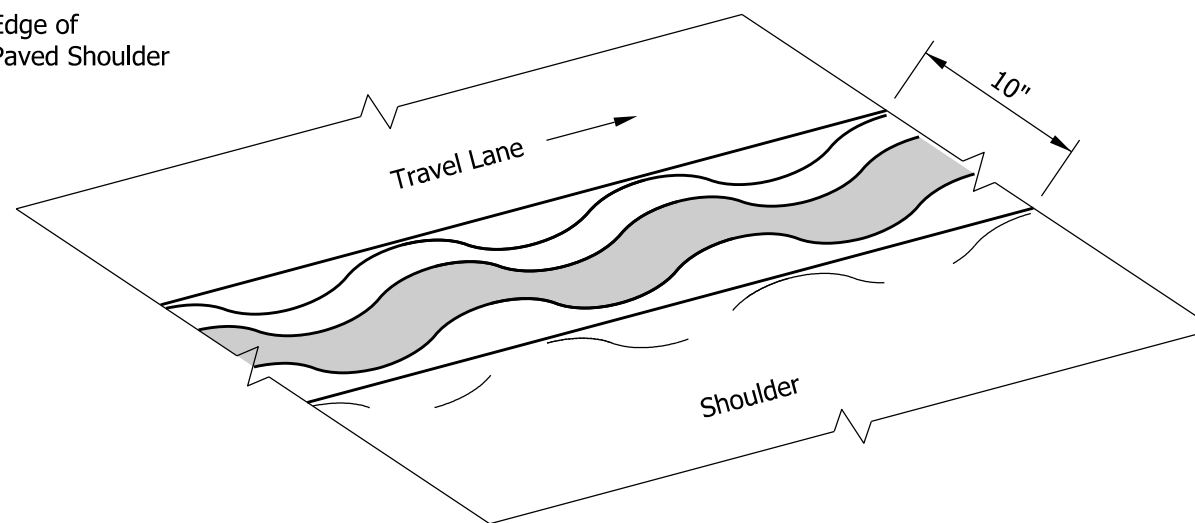

ISOMETRIC VIEW

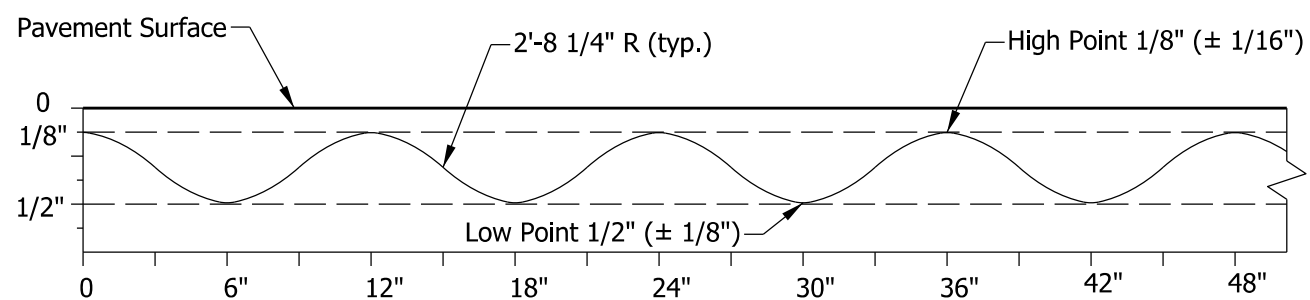

PROFILE

NOTES:

1. Where the paved shoulder width is at least 2 ft, a 12-ft longitudinal gap in the corrugations shall be provided every 60 ft to accommodate bicycles.
- ② If shoulder joint is present, the liquid asphalt sealant width shall be a minimum of 24 in. centered on the shoulder joint line.
3. The corrugations shall be no closer than 6 in. to a casting or a concrete pavement transverse joint.
- ④ Near edge of travel lane if shoulder joint is not apparent.

INDIANA DEPARTMENT OF TRANSPORTATION

EDGELINE RUMBLE STRIPES

EFFECTIVE FOR LETTINGS ON OR AFTER 03-01-23

RECURRING PLAN DETAIL NO. 606-T-234d

Sheet 07 of 09

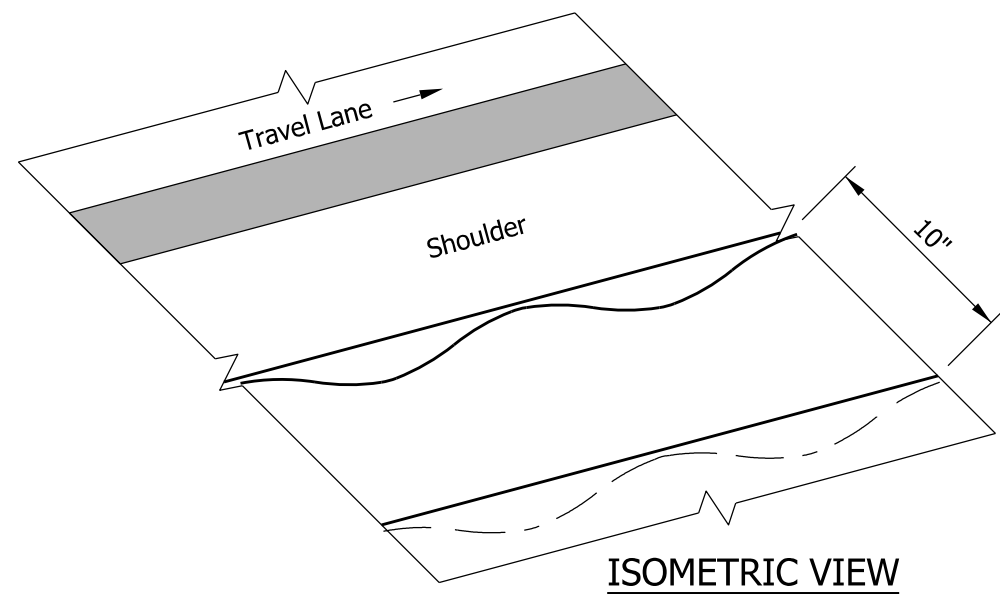
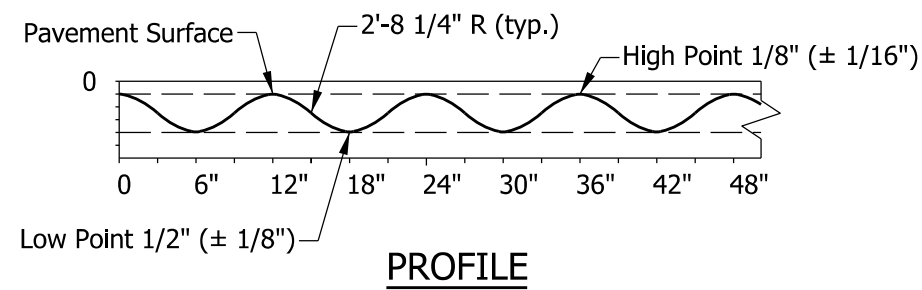
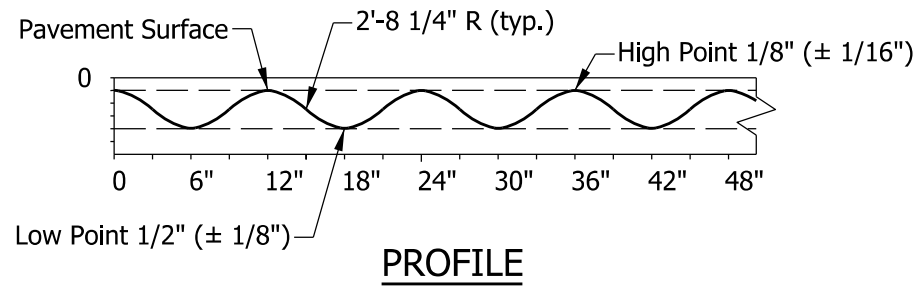
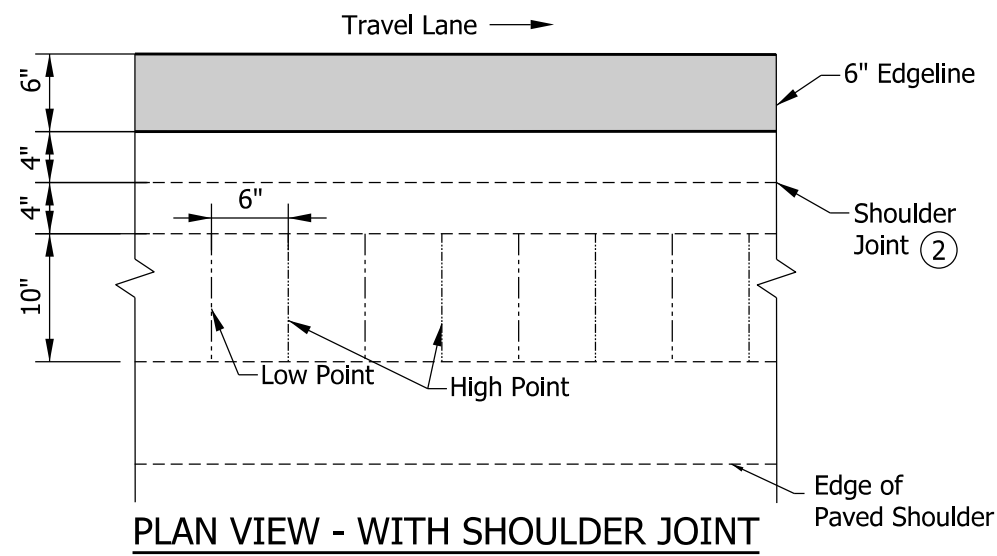
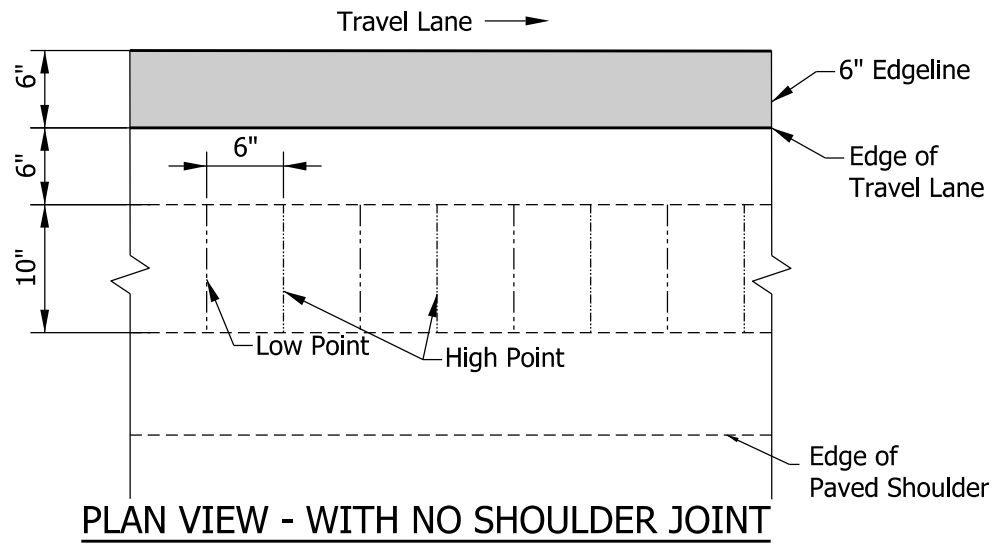

**NOTES:**

1. Where the paved shoulder width is at least 3 ft, a 12 ft longitudinal gap in the corrugations shall be provided every 60 ft to accommodate bicycles.
- ② The liquid asphalt sealant width shall be a minimum of 24 in. centered on the shoulder joint line.
3. The corrugations shall be no closer than 6 in. to a casting.

INDIANA DEPARTMENT OF TRANSPORTATION

SHOULDER RUMBLE STRIPS  
(UNDIVIDED HIGHWAY)

EFFECTIVE FOR LETTINGS ON OR AFTER 03-01-23

RECURRING PLAN DETAIL NO. 606-T-234d



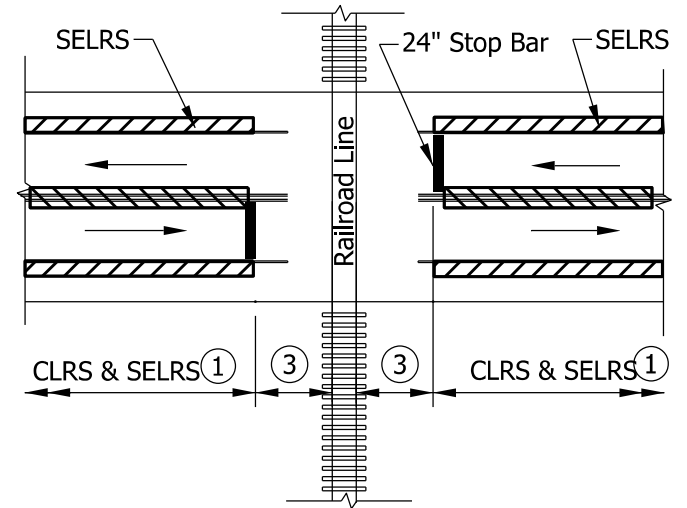
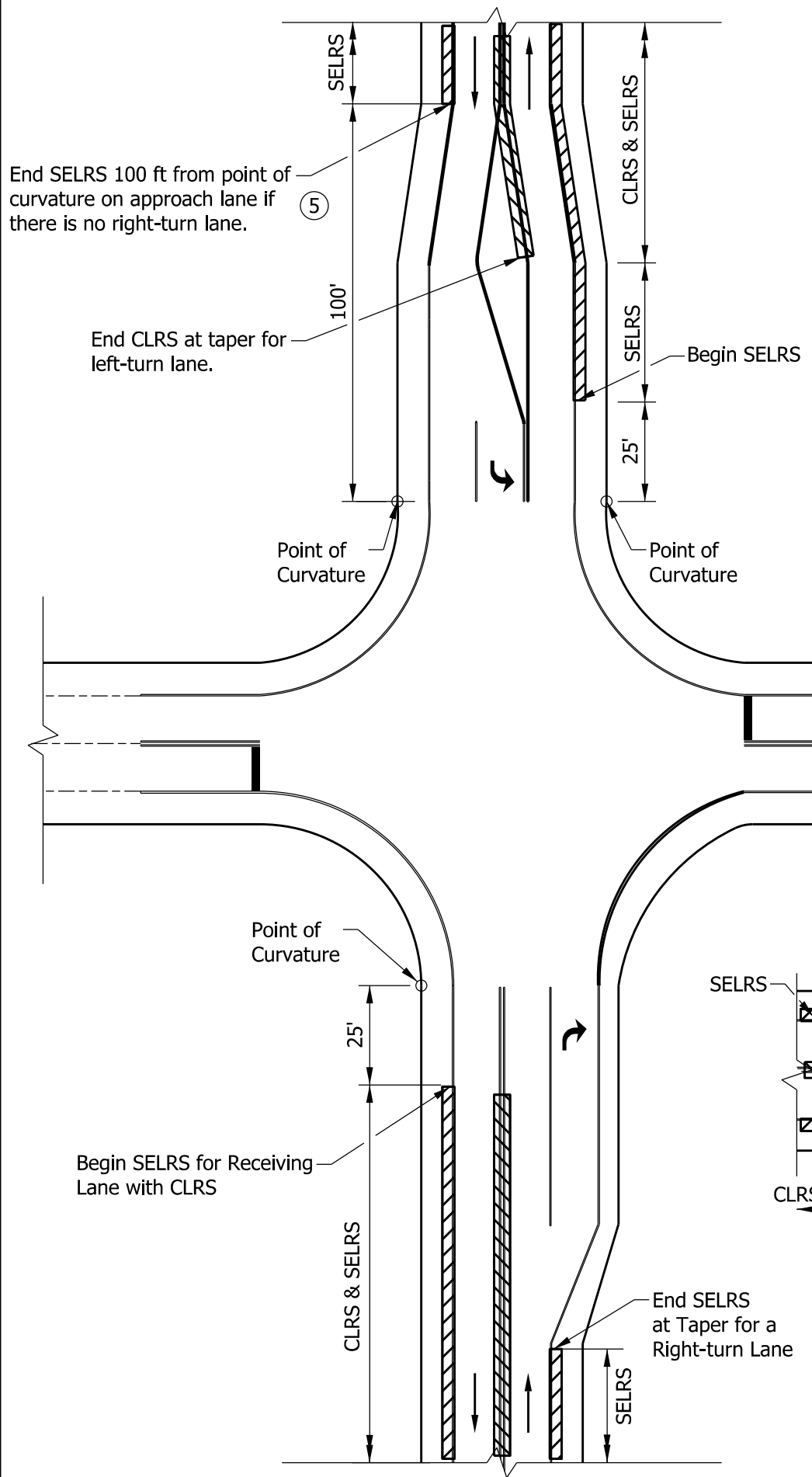

**BREAK NEAR A RAILROAD CROSSING**

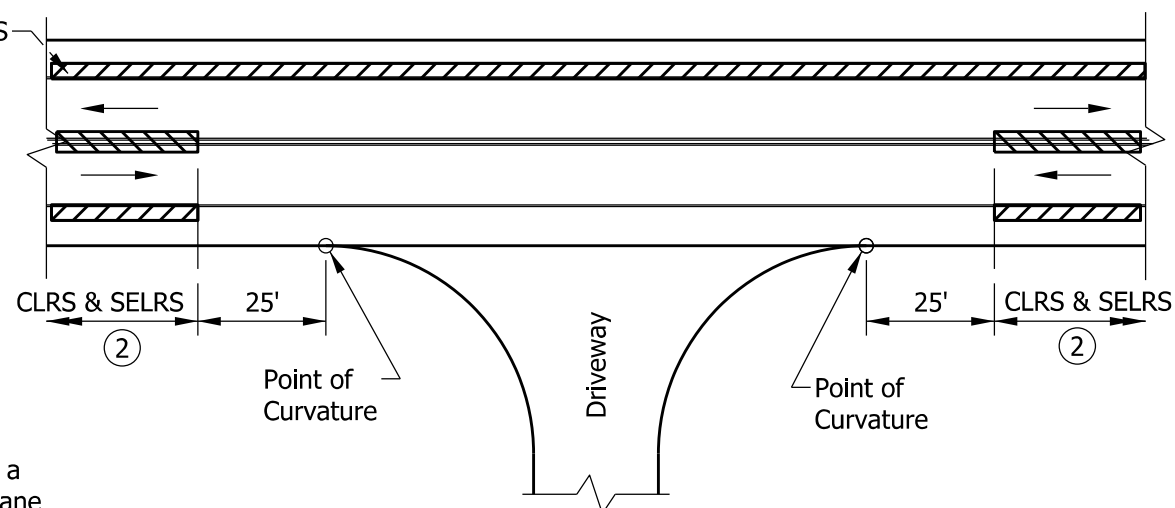

**BREAK NEAR A COMMERCIAL OR INDUSTRIAL DRIVEWAY**

**BREAK NEAR AN INTERSECTION**

**NOTES:**

- ① Corrugations shall begin or end at the stop bar location.
- ② Corrugations shall be continued through driveway access points for minor driveways.
- ③ Gap shall be 15 ft for a railroad crossing without gates or signals and 25 ft for railroad crossing with gates or signals.
- 4. For a bridge deck, end corrugations a maximum of 5 ft and a minimum of 6 in. before an approach slab and begin corrugations a minimum of 6 in. and a maximum of 5 ft after the approach slab on the other side of the bridge deck.
- ⑤ If there is no right-turn lane and the paved shoulder width is 8 ft or greater the corrugations shall end 400 ft from the point of curvature on approach lane.

**KEY:**

CLRS = Centerline Longitudinal Rumble Stripe  
 SELRS = Shoulder Longitudinal Rumble Strip or Edgeline Longitudinal Rumble Stripe

INDIANA DEPARTMENT OF TRANSPORTATION

RUMBLE STRIP LIMITS:  
 INTERSECTION, DRIVE, BRIDGE,  
 OR RAILROAD

EFFECTIVE FOR LETTINGS ON OR AFTER 03-01-23

RECURRING PLAN DETAIL NO. 606-T-234d