

2 - Threaded 19 ø reduced weld base stud x 51 long (see Detail) w/1- \bar{r} washer C (see Detail) 1 lock washer and nut @ 100 ga.

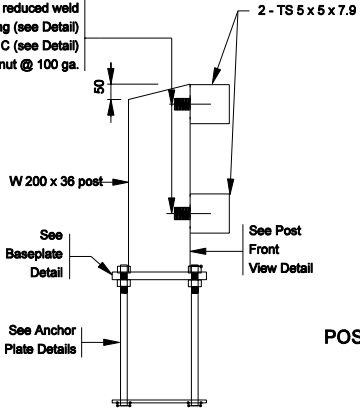

SECTION A - A

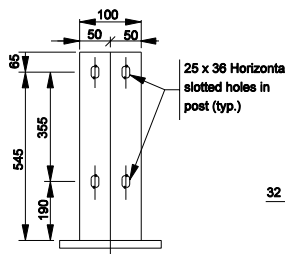

POST FRONT VIEW DETAIL

NOTES:

1 Gap of 25 unless noted otherwise on plans. Railing splice required in panel with a deck expansion joint.

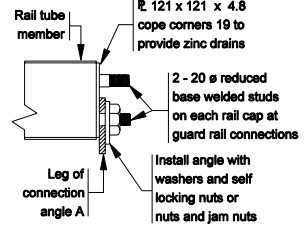
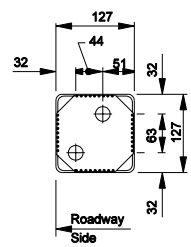

RAIL CAP DETAIL

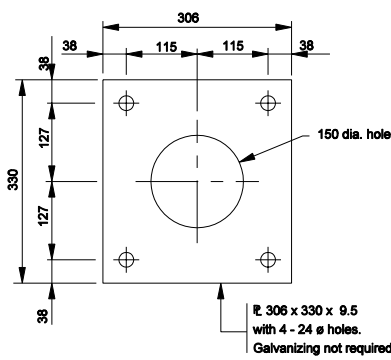

SECTION B - B ANCHOR PLATE DETAILS

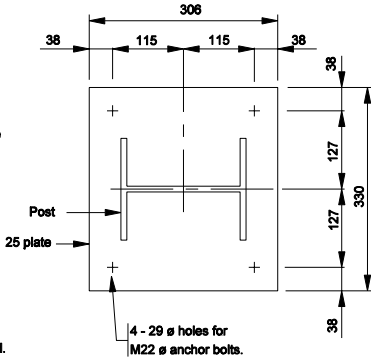

BASE PLATE DETAILS

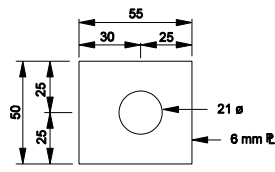
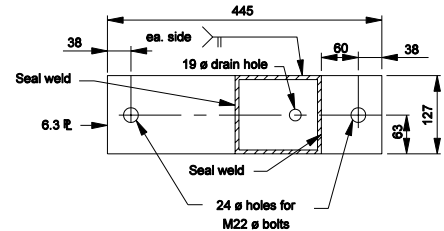
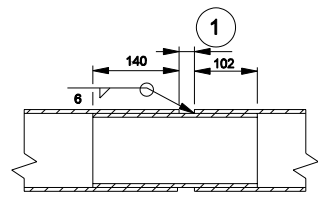

PLATE WASHER C DETAIL



TOP RAIL END VIEW B - B



RAILING SPLICE DETAILS

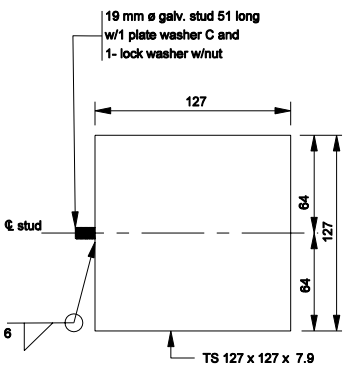
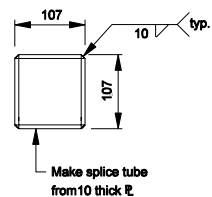

BASE WELD STUD DETAIL

All Dimensions are in mm unless otherwise specified

INDIANA DEPARTMENT OF TRANSPORTATION	
RAILING, CF-1	
MARCH 2006	
STANDARD DRAWING NO. 706-BRTM-02	
	/s/ Richard L. VanCleave 3-01-06 DESIGN STANDARDS ENGINEER DATE
	/s/ Richard K. Smutzer 3-01-06 CHIEF HIGHWAY ENGINEER DATE
DESIGN STANDARDS ENGINEER	