

**FIXED SHOE ASSEMBLY**

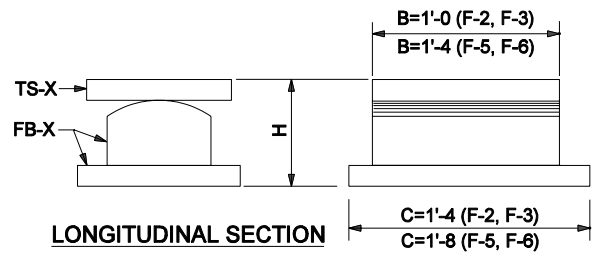

**LONGITUDINAL SECTION**

Shoe Type	Maximum Reaction	Shoe Assembly		H
		TS-X	FB-X	
F-2	177 k	TS-2	FB-2	7 1/8
F-3	245 k	TS-3	FB-3	7 3/4
F-5	225 k	TS-5	FB-5	7 7/8
F-6	309 k	TS-6	FB-6	7 3/4

**NOTES :**

- Curved surfaces of shoes to be machined after weldments have been completed. At the contractor's option the following substitutions of materials will be allowed at no increase in unit price of material:

- A-709 Grade 50W steel may be used in lieu of A-709 Grade 36 steel.
  - A-709 Grade 100 steel may be used in lieu of A-709 Grade 50W or A-709 Grade 36 steel.
- Section "pb" to be finished from 4" thickness while Section "pc" is to be straightened.
  - Maximum horizontal thrust per Fixed Shoe = 5000 lb.

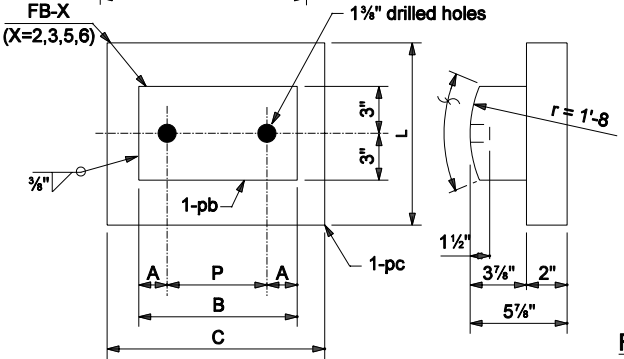
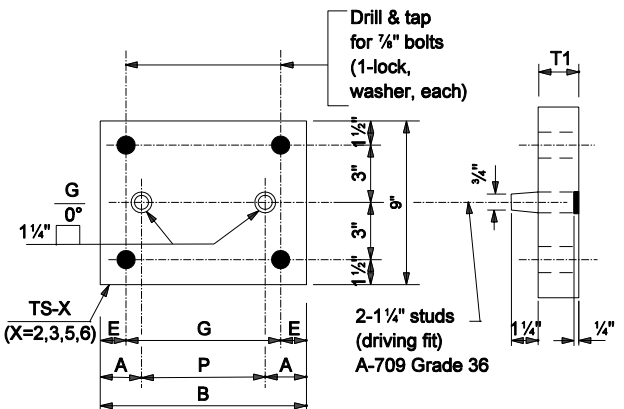

TS-X	B	T1	E	G	A	P	Section	Material
TS-1*	1'-0"	1 3/4	2 1/4	7 1/2	2 1/4	7 1/2	ℙ 9 x 1 3/4	A-709 Grade 36
TS-2	1'-0"	2	2 1/4	7 1/2	2 1/2	7	ℙ 9 x 2	A-709 Grade 50W
TS-3	1'-0"	1 1/2	2 1/4	7 1/2	2 1/4	6 1/2	ℙ 9 x 2	A-709 Grade 100
TS-4*	1'-4"	1 1/4	3	10	3	10	ℙ 9 x 1 3/4	A-709 Grade 36
TS-5	1'-4"	2	3	10	3 1/4	9 1/2	ℙ 9 x 2	A-709 Grade 50W
TS-6	1'-4"	1 1/2	3	10	3 1/2	9	ℙ 9 x 2	A-709 Grade 100

\* Top shoe used with Expansion Steel Shoe only.

**TOP SHOE**

FB-X	C	L	B	A	P	Sections	
						pb	pc
FB-2	1'-4	1'-0	1'-0	2 1/2"	7	ℙ 6 x 4	ℙ 12 x 2
FB-3	1'-4	1'-4	1'-0	2 3/4"	6 1/2"	ℙ 6 x 4	ℙ 16 x 2
FB-5	1'-8	1'-0	1'-4	3 1/4"	9 1/2"	ℙ 6 x 4	ℙ 12 x 2
FB-6	1'-8	1'-4	1'-4	3 1/2"	9	ℙ 6 x 4	ℙ 16 x 2

**FIXED BASE**

INDIANA DEPARTMENT OF TRANSPORTATION

**FIXED STEEL SHOE DETAILS**

MARCH 2005

STANDARD DRAWING NO. E 711-BSTS-01

	/s/ Richard L. VanCleave	3-01-05
	DESIGN STANDARDS ENGINEER	DATE
	/s/ Richard Smutzer	3-01-05
	CHIEF HIGHWAY ENGINEER	DATE

DESIGN STANDARDS ENGINEER