

PLAN

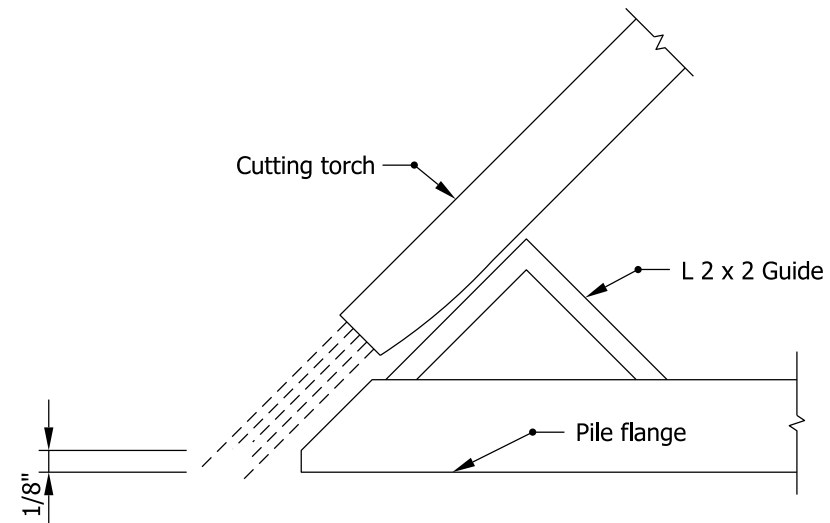

SUGGESTED METHOD TO BEVEL FLANGE

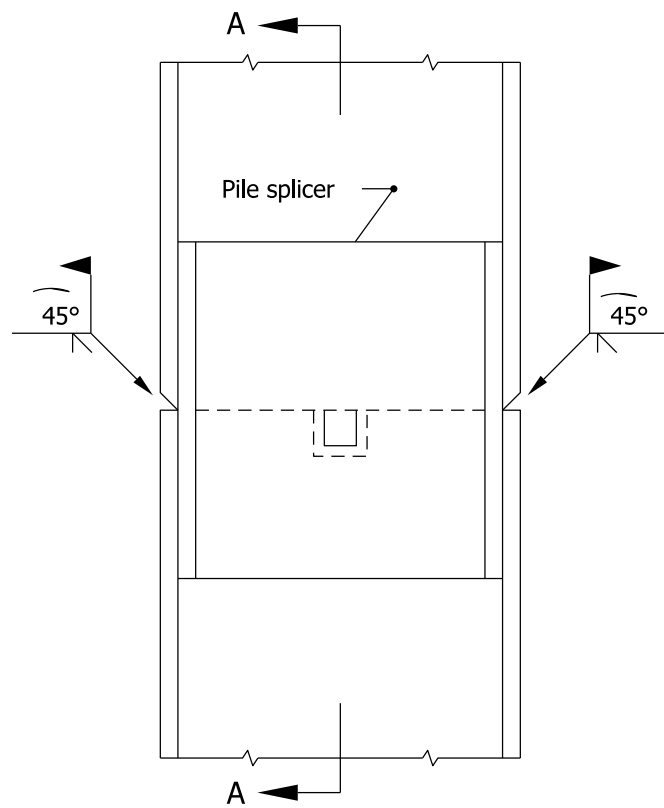

ELEVATION

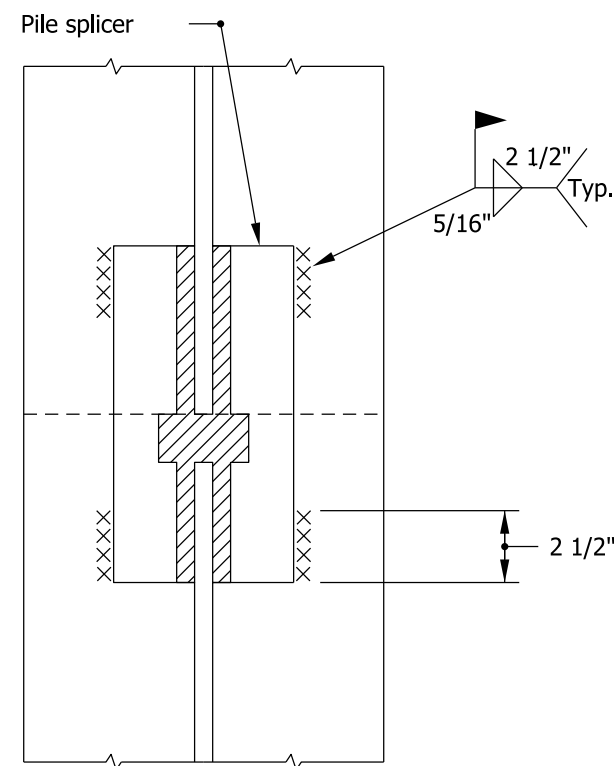

SECTION A-A

ALTERNATE STEEL H PILE SPLICE  
USING COMMERCIAL PILE SPLICER

INDIANA DEPARTMENT OF TRANSPORTATION	
ALTERNATE STEEL H-PILE SPLICE	
SEPTEMBER 2009	
STANDARD DRAWING NO.	E 701-BPIL-06
	<i>/s/ Richard L. VanCleave</i> 09/01/09 DESIGN STANDARDS ENGINEER      DATE
	<i>/s/ Mark A. Miller</i> 09/01/09 CHIEF HIGHWAY ENGINEER      DATE
DESIGN STANDARDS ENGINEER	