

Min. steel area $0.12 \text{ in}^2 / \text{ft}$ of width in both directions.

Opening additionally reinforced with equivalent of $0.20 \text{ in}^2 / \text{ft} @ 90^\circ$

Straight rods, min length = dia. of opening plus 2".

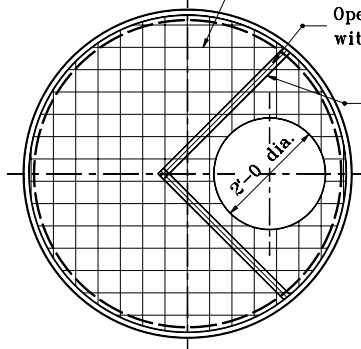

DETAIL A

COVER CAP FOR PRECAST CONCRETE MANHOLE SECTION

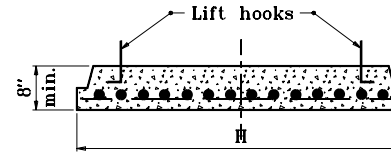

Min. steel area $0.12 \text{ in}^2 / \text{ft}$ of width in both directions. Rebar or wire mesh equivalent.

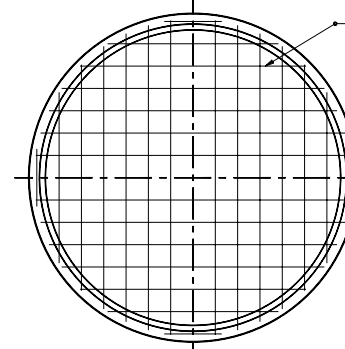

DETAIL C

BASE FOR PRECAST CONCRETE MANHOLE SECTIONS (5'-0 to 9'-0 DIA.)

Section Dia.	H
5'-0	6'-0
6'-0	7'-2
8'-0	9'-6
8'-6	10'-0
9'-0	10'-8

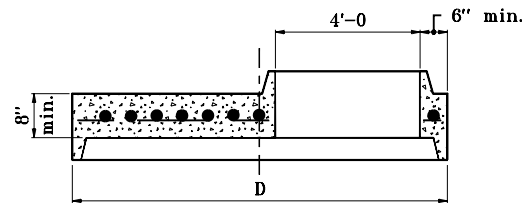

Min. steel area $0.12 \text{ in}^2 / \text{ft}$ of width in both directions.

Opening additionally reinforced with equivalent of $0.20 \text{ in}^2 / \text{ft} @ 90^\circ$

Straight rods, min length = dia. of opening plus 2".

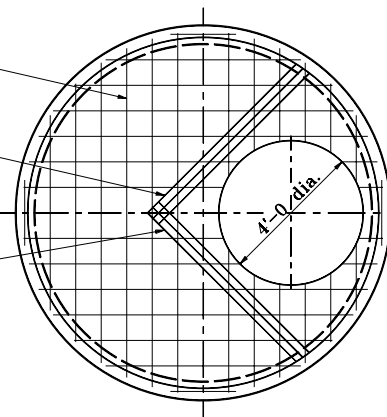

DETAIL B

REDUCER CAP FOR PRECAST MANHOLE SECTION (5'-0 to 9'-0 DIA.)

Section Dia.	D
5'-0	6'-0
6'-0	7'-2
8'-0	9'-6
8'-6	10'-0
9'-0	10'-8

INDIANA DEPARTMENT OF TRANSPORTATION
PRECAST CONCRETE MANHOLE SECTIONS
 APRIL 1995

STANDARD DRAWING NO. **E 720-MHST-06**

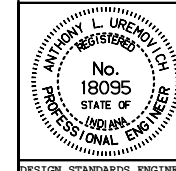

DETAILS PLACED IN THIS FORMAT 11-15-99

/s/ Anthony L. Uremovich 11-15-99
 DESIGN STANDARDS ENGINEER DATE

/s/ Firooz Zandi 11-15-99
 CHIEF HIGHWAY ENGINEER DATE

DESIGN STANDARDS ENGINEER

ORIGINALLY APPROVED 4-03-95