

NOTES :

- ② The limits for X are based on a 6" curb height. For other curb heights, the limits for X shall be adjusted.
3. See Standard Drawing E 604-SDWK-01 or E 604-SDWK-02 for sidewalk elevation transition details.
4. See Standard Drawing E 610-DRIV-13 for General Notes.

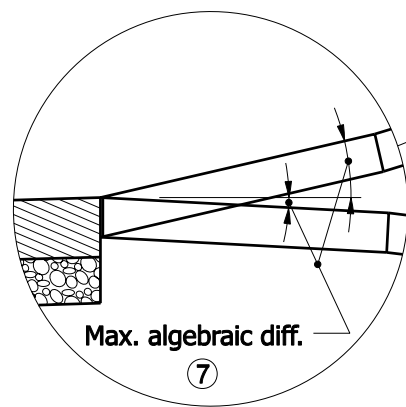

LEGEND

- W = Width of sidewalk
- X = Distance between back face of curb and sidewalk.
- Y = Distance from front face of curb to R or R/W
- Sidewalk elevation transition section view.
- PCCP

INDIANA DEPARTMENT OF TRANSPORTATION	
CLASS I AND CLASS III DRIVE GRADE PROFILES	
SEPTEMBER 2008	
STANDARD DRAWING NO. E 610- DRIV-08	
	<p><i>/s/ Richard L. VanCleave</i> 09/02/08 DESIGN STANDARDS ENGINEER DATE</p> <p><i>/s/ Mark A. Miller</i> 09/02/08 CHIEF HIGHWAY ENGINEER DATE</p>
DESIGN STANDARDS ENGINEER	