

**CABINET SIDE PANEL
POWER DISTRIBUTION**

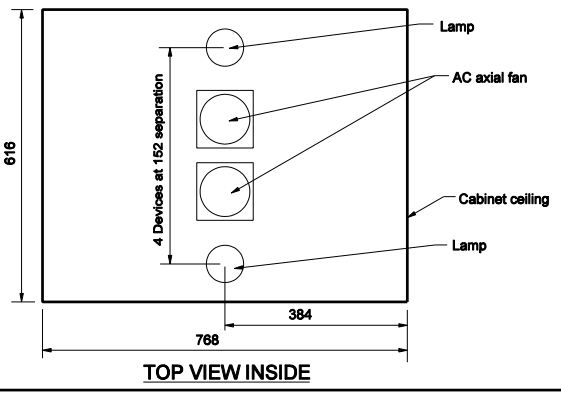

TOP VIEW INSIDE

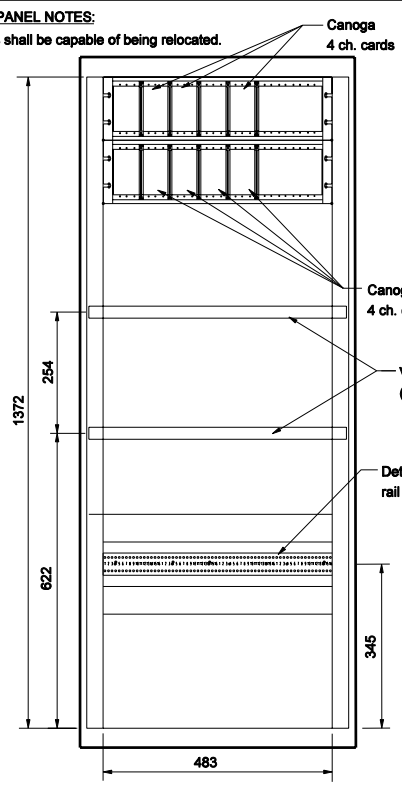

FRONT ELEVATION

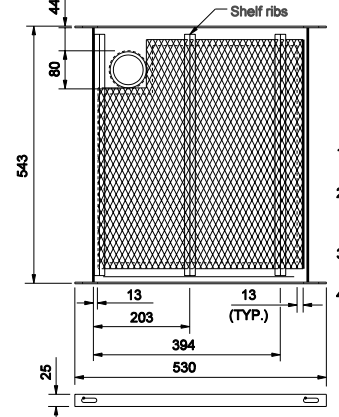

**VENTILATED CABINET
SHELF BOTTOM VIEW**

- VENTILATED SHELF NOTES:**
- Tack weld screen to bottom of shelf.
 - Tack weld ribs over screen to bottom of shelf in locations shown.
 - Press bushing in from top of shelf.
 - Material Notes:**
Shelf frame-3 alum.
screen-3 expanded alum.w/13 mesh
ribs - 3 x 16 x 16 alum. angle

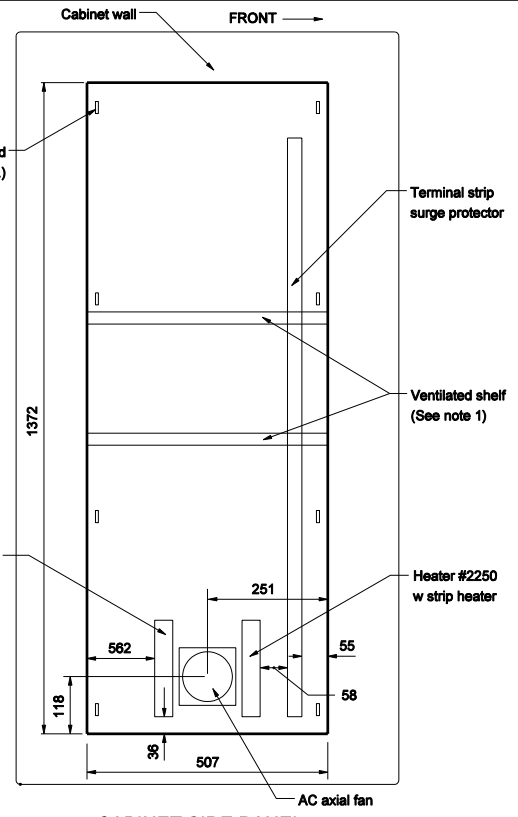

**CABINET SIDE PANEL
HEATER**

NOTES:
1. See Standard Drawings 809-ITCS-01, -01A or -03 thru -07 for additional ITS cabinet details.

All dimensions are in mm unless otherwise specified

INDIANA DEPARTMENT OF TRANSPORTATION

INDOT ITS CABINET SCHEMATIC

MARCH 2006

STANDARD DRAWING NO. 809-ITSC-02

	/s/ Richard L. VanCleave	3-01-06
	DESIGN STANDARDS ENGINEER	DATE
	/s/ Richard K. Smutzer	3-01-06
	CHIEF HIGHWAY ENGINEER	DATE

DESIGN STANDARDS ENGINEER