

ITEM DESCRIPTIONS

- ① Hitch pin
- ② 3/4" dia. reversible electric motor 120 V, 11.5 A, 350 RPM
- ③ Reversing drum switch
- ④ Control cord 20 ft. length
- ⑤ Wiring housing
- ⑥ Plug to mate to connector in pole base or transformer secondary
- ⑦ Torque limiter coupling
- ⑧ 3/4" dia. steel shaft
- ⑨ Ballbearing pillowblock
- ⑩ 5/8" hex socket crank shaft coupling
- ⑪ Connector to motor from 120 V transformer secondary
- ⑫ Stepdown transformer 120 V secondary, 1.5 kVA for 240 V, 277 V, & 480 V; 2.0 kVA for 208 V
- ⑬ 1/2" carry handle
- ⑭ Plug to connector in pole base from transformer primary
- ⑮ NEMA 4-circuit-breaker enclosure field mounted to pole handhole door
- ⑯ 1/2" dia. mounting bolt, 4 req'd.
- ⑰ 0.25 in. thick steel winch plate zinc electroplate finish
- ⑱ Power unit mounting bracket, 0.25 in. thick steel zinc electroplate finish
- ⑲ 5 ft. power supply cord and connector
- ⑳ Winch 30:1 gear ratio internal drag brake
- ㉑ 5/16" dia. 7 x 19 wire rope. Length is pole height + 6 ft. stainless steel
- ㉒ Forged steel swivel, 11,000 psi ultimate strength
- ㉓ Cord grip
- ㉔ Winch cable guard
- ㉕ Winch outboard support

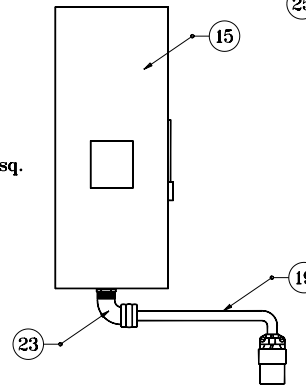
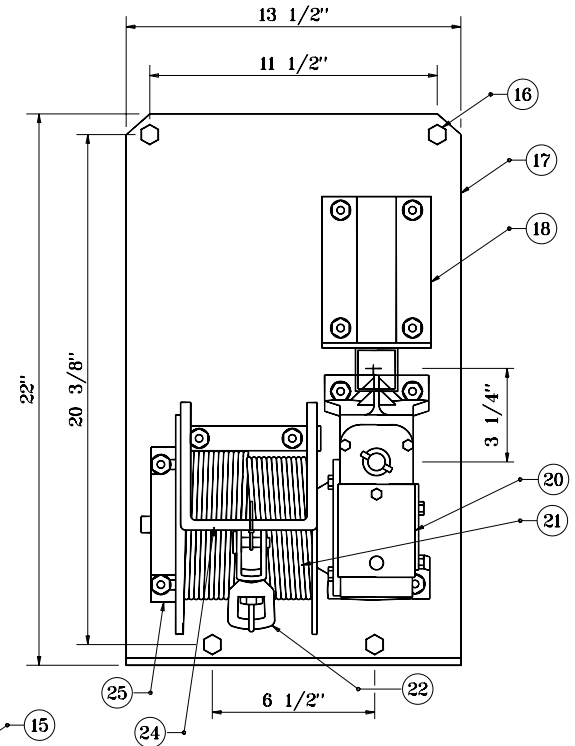
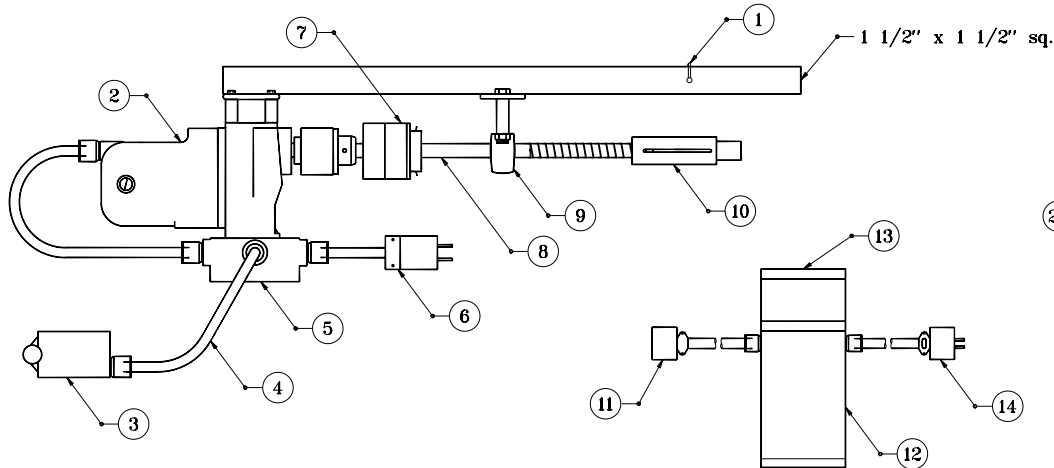

INDIANA DEPARTMENT OF TRANSPORTATION
HIGHWAY ILLUMINATION TOWER
DETAILS - BOTTOM LATCH
 JANUARY 1999

STANDARD DRAWING NOE 807-LTHI-03A

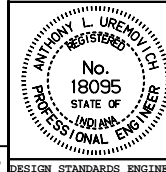

/s/ Anthony L. Uremovich 1-04-99
 DESIGN STANDARDS ENGINEER DATE

/s/ Donald W. Lucas 1-04-99
 CHIEF HIGHWAY ENGINEER DATE

Source Sheet: None