

Elastomeric Bearing Pads Updates

Mark Swiderski, P.E.
INDOT Bridge Design
mswiderski@indot.in.gov







1

1

Design Memo No. 20-11

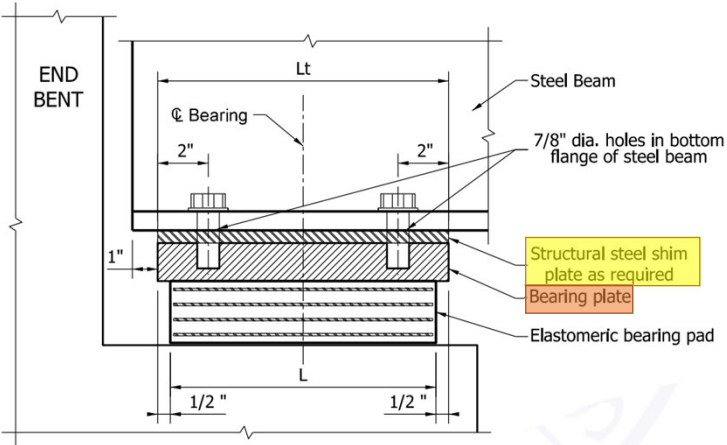
- Released in August of 2020
- Changes were to made to INDOT Design Manual Section 409 and its figures.





2

2

IDM 409-7.03(03)

- Load plates should be of uniform size where possible to limit number of tests.
- Use shims to accommodate differences on steel beams and tapered load plates on prestressed beams.

The requirement for a tapered plate shall be determined in accordance with *LRFD* 14.8.2. See Figure 409-7F for a typical elastomeric bearing pad with tapered steel plate. In order to minimize the number of bearings that are required to be randomly tested on a contract, load plates which are required to be vulcanized to the pads should be of a consistent size and thickness whenever feasible. Variations in taper rates should be accommodated by using tapered shims between the load plate and bottom flange on steel superstructure bridges, and tapered load plates on prestressed beam superstructure bridges. Plates should not be tapered when the calculated difference in thickness between the parallel edges is less than 1/8 in. Stainless steel should be considered only when located beneath an expansion joint. When a stainless steel tapered plate is specified, the steel plate cast with the beam, steel stud, and welds must also be specified as stainless steel.

NextLevel
INDIANA

3

3

IDM 409-7.04

- Tapered Plates should not be used when difference in thickness is less than 1/8"

Rotational Deflection. Sufficient pad thickness or a tapered plate/shim shall be provided to prevent a liftoff condition on the leading edges of the device. Tapered plates should not be used where the calculated difference in thickness between parallel edges is less than 1/8 in.

NextLevel
INDIANA

4

4

IDM 409-7.05

- Elastomeric and PTFE Bearings are to be vulcanized to steel plates even when design calculations indicate it is not required.

Elastomeric and PTFE bearings are to be vulcanized to a steel load plates in order to mechanically secure the bearing pad in place. This requirement should be followed even where design calculations indicate that there is sufficient frictional resistance to hold the bearing pad in place under longitudinal and transverse movements and loadings. In situations where it may not be feasible to vulcanize the bearing pad to a load plate, such as adjacent box beam bridges, other methods of securing the bearing pad should be provided, such as recesses formed in the bearing seats. Vulcanization and other connection details should be shown on the plans. The minimum thickness for a steel load plate should be 1 ¼ in. where the plate is tapped for bolted connections, and 3/4 in. for all other cases.

5

IDM 409-7.05

- ¼" Minimum gap between side retainer and the top plate or edge of flange.

diameter shall be provided for each side retainer. The gap between the side retainer and the top plate or edge of flange should be determined by design so that the retainers are not engaged during routine service loads, including thermal movements. However, the gap should be at least 1/4 in. to allow for construction tolerances.

6

IDM Fig. 409-7J

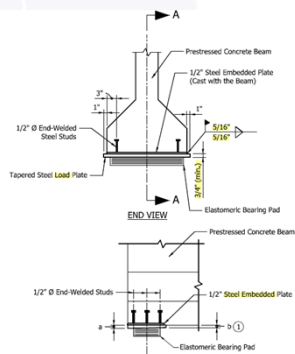

- NOTES:**
1. Taper top of steel plate to the nearest 1/8" to correct for slope. Tapered shim plates should not be used where the calculated difference in thickness between parallel edges is less than 1/8".
 2. When stainless steel is specified, plate cast with beam, studs, and weld must all be specified as stainless steel.
 3. The elastomeric bearing pad should be vulcanized to the steel load plate.
 4. A tapered shim should be used in lieu of a tapered load plate for steel superstructures. See Fig. 409-7J for details.

ELASTOMERIC BEARING PAD WITH TAPERED STEEL LOAD PLATE

Figure 409-7F
[Rev. Aug. 2020]



IDM Fig. 409-7J

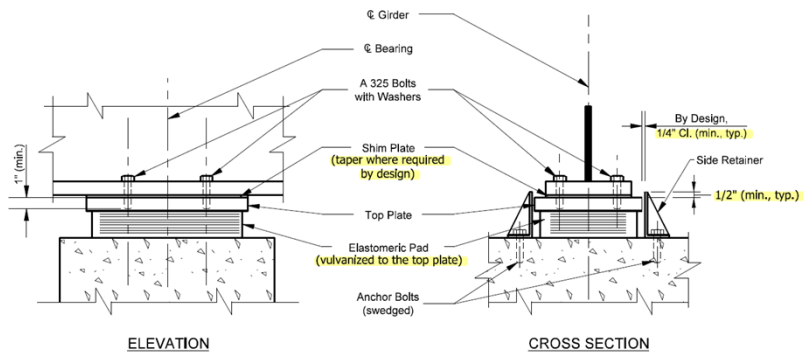

ELASTOMERIC BEARING ASSEMBLY

Figure 409-7J

[Rev. Aug. 2020]



IDM Fig. 409-7L

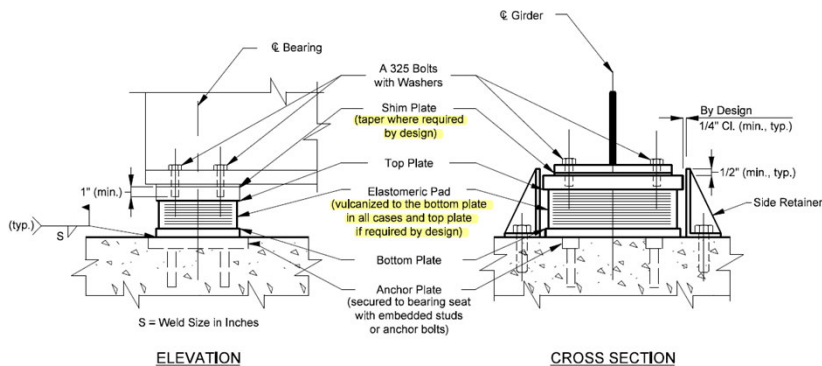

ELASTOMERIC BEARING ASSEMBLY WITH BOTTOM PLATE

Figure 409-7L
[Rev. Aug. 2020]



9

9

IDM Fig. 409-7M

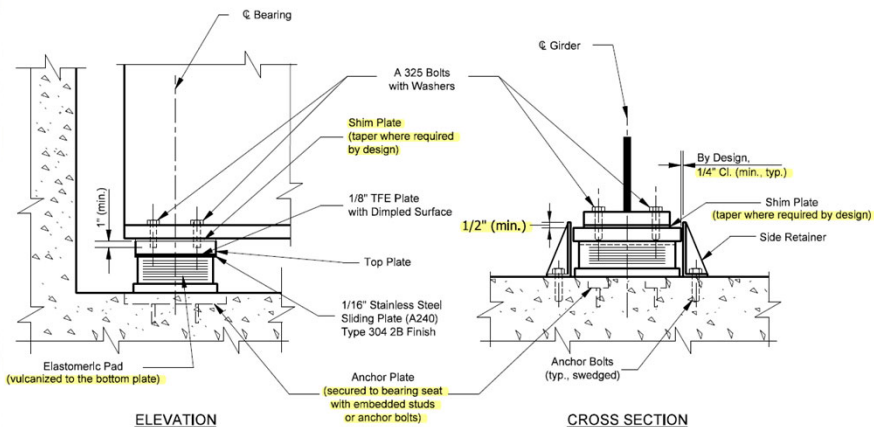

PTFE ELASTOMERIC BEARING ASSEMBLY

Figure 409-7M
[Rev. Aug. 2020]



10

10

Questions

NextLevel INDIANA

11

11