

INDOT BRIDGE INSPECTION MANUAL

PART 1

ADMINISTRATION

BRIDGE INSPECTION MANUAL

PART 1: ADMINISTRATION

TABLE OF CONTENTS

| | |
|---|-----------|
| LIST OF FIGURES | 2 |
| INTRODUCTION..... | 3 |
| 1-1.0 PROGRAM OVERVIEW..... | 4 |
| 1-1.01 Program Summary | 4 |
| 1-1.02 Inspection Program | 4 |
| 1-1.03 Organization | 5 |
| 1-1.04 Qualifications and Responsibilities..... | 5 |
| <i>1-1.04(01) State Program Manager (SPM)</i> | <i>5</i> |
| <i>1-1.04(02) Assistant State Program Manager ASPM-R&P) – Rating & Posting.....</i> | <i>8</i> |
| <i>1-1.04(03) Assistant State Program Manager (ASPM-BI&I) – Bridge Inspection & Inventory</i> | <i>8</i> |
| <i>1-1.04(04) Bridge Inspection Area Engineer (BIAE).....</i> | <i>10</i> |
| <i>1-1.04(05) I N D O T Bridge Inspection Engineer (BIE)</i> | <i>12</i> |
| <i>1-1.04(06) Bridge Inspection Consultant (BIC).....</i> | <i>13</i> |
| <i>1-1.04(07) Approved Team Leader (ATL).....</i> | <i>14</i> |
| <i>1-1.04(08) Complex Bridge Approved Team Leader</i> | <i>16</i> |
| <i>1-1.04(09) Fracture Critical Approved Team Leader (ATL-F)</i> | <i>17</i> |
| <i>1-1.04(10) Underwater Approved Team Leader (ATL-U).....</i> | <i>17</i> |
| <i>1-1.04(11) Approved Team Member (ATM)</i> | <i>18</i> |
| <i>1-1.04(12) Nondestructive Testing Specialists.....</i> | <i>19</i> |
| <i>1-1.04(13) Divers.....</i> | <i>19</i> |
| <i>1-1.04(14) Load Rating Engineer (LRE)</i> | <i>19</i> |
| <i>1-1.05 Bridge Inspection Database</i> | <i>20</i> |
| FIGURES | 22 |

BRIDGE INSPECTION MANUAL

PART 1: ADMINISTRATION

LIST OF FIGURES

| <u>FIGURE</u> | <u>TITLE</u> |
|---------------|--|
| 1-1.1: | Bridge Structure Measurements |
| 1-1.2: | State Bridge Inspection Program Organization |
| 1-1.3: | Bridge Inspection Positions |

BRIDGE INSPECTION MANUAL

PART 1: ADMINISTRATION

INTRODUCTION

Part 1 of the Bridge Inspection Manual contains the following chapters:

1. Program Overview
2. Types of Inspections
3. Reporting Systems
4. Emergency Notifications / Critical Findings

These chapters define the qualifications required to become a team leader and the procedures that the team leader must follow. The performance expectations and responsibilities are provided in part 1 of this manual. While other portions of the manual provide recommendations and guidance for the inspector, Part 1 provides the regulatory guidance and outlines the requirements that must be performed in order to provide the documents in the format and timely manner necessary for INDOT to fulfill the requirements of the National Bridge Inspection Standards.

BRIDGE INSPECTION MANUAL

PART 1: ADMINISTRATION

1-1.0 PROGRAM OVERVIEW

1-1.01 Program Summary

It is important for the safety of the driving public that qualified personnel inspect Indiana's bridges and large culverts. The Bridge Inspector is required to render judgment pertaining to the safety and integrity of the structures inspected.

The individuals involved in the State Bridge Inspection Program have critical input on many issues, including the allocation of scarce rehabilitation funds and the decision to close major bridges. It is important that the Inspector is highly trained and proficient; he/she must understand the mechanics, behavior trends, and economics of a wide range of bridge types.

Indiana's State Bridge Inspection Program operates under the directives of the Federal Highway Administration (FHWA) and the Indiana Department of Transportation (INDOT). The mission of the program is as noted below:

1. Ensure public safety.
2. Provide for the efficient use of resources in maintaining the serviceability of Indiana's bridges and large culverts.
3. Comply with all federal and state laws, rules, and policies.
4. The State is given the responsibility to accurately inventory and inspect all highway bridges on public roads. The State shall inspect the bridges on its highways and delegates this responsibility to the counties to accurately inventory and inspect their bridges on public roads.
5. The failure of a county to perform these responsibilities may cause a loss or reduction of funding. The State shall have the authority to take the appropriate action to assure bridge safety. These actions will include that the bridge has been inspected at the proper frequency, that if necessary, the bridge is posted, and that the posting is done in a timely manner. The State has the authority to close unsafe bridges.

1-1.02 Inspection Program

The State Bridge Inspection Program is federally mandated and has been in effect since 1971. The program policies are based on the National Bridge Inspection Standards (NBIS). Bridge inspection reports are stored in BIAS (Bridge Inspection Application System) and records are kept in ERMS (Electronic Records Management System). The required bridge data is forwarded to the FHWA on an annual basis.

BRIDGE INSPECTION MANUAL

PART 1: ADMINISTRATION

NBIS define a bridge as a structure, including supports, erected over a depression or an obstruction, such as water, highway, or railway. It has a track or passage way for carrying traffic or other moving loads, and has an opening measured along the center of the roadway of more than twenty feet between under copings of abutments or spring lines of arches, or extreme ends of openings for multiple boxes. It may also include multiple pipes, where the clear distance between openings is less than half of the smaller contiguous opening.

This manual will address all bridges meeting this definition, as well as large culverts spanning between 4-and 20 feet. Refer to [Figures 1:1-1](#) for the defining bridge measurements.

1-1.03 Organization

The State Program Manager (SPM) is charged with administering the State Bridge Inspection Program. The INDOT Bridge Inspection Engineers (BIE), State/Toll Road/County/Local Bridge Inspection Consultants report to the State Program Manager. Approved Team Leaders report to the appropriate INDOT Bridge Inspection Engineer, the Toll Road Operating Engineer, or Bridge Inspection Consultant. Approved Team Members report to their Approved Team Leaders.

The Assistant State Program Managers (ASPM) are charged with either the overall responsibility for load rating and posting of bridges or assisting the SPM in administering the Inspection Program.

The organization of the State Bridge Inspection Program is shown in [Figure 1:1-2](#) and described in detail later in this section. The review and quality assurance/quality control procedure are discussed in Part 2, Quality Assurance/Quality Control.

1-1.04 Qualifications and Responsibilities

Below are listed the qualifications required for the various bridge inspection positions and categories. To apply for these, one must submit an Inspection Qualifications Form.

The Inspection Qualification Form can be found online at:

<https://www.in.gov/dot/div/contracts/standards/bridge/INDOT-QualForm.docx>

The various Bridge Inspection Positions are summarized in a table in [Figure 1:1-3](#).

1-1.04(01) State Program Manager (SPM)

The SPM is responsible for setting all bridge inspection policies and procedures, and for all bridge inspections and related reporting in the state.

BRIDGE INSPECTION MANUAL

PART 1: ADMINISTRATION

SPM Minimum Qualifications

The SPM must meet the following minimum qualifications:

1. Capable of overseeing the INDOT Bridge Inspection Engineers (BIE), all Bridge Inspection Consultants (BIC).
2. Sound background in bridge inspection.
3. Specialized knowledge and skills in bridge design, construction, soils, construction materials, and emergency repair techniques.
4. Successful completion of the Safety Inspection of In-Service Bridges (FHWA-NHI-130055) course or Safety Inspection of In-Service Bridges for Professional Engineers (FHWA-NHI-130056).
5. Successful completion of the Fracture Critical Inspection Techniques for Steel Bridges (FHWA-NHI-130078) course.
6. Registered Professional Engineer (PE) in the state of Indiana.

SPM Responsibilities

As a part of the responsibilities of this position, the SPM shall:

1. Oversee the INDOT BIE, all Inspection Consultants and for setting all bridge inspection policies and procedures
2. Manage the statewide bridge inspection and inventory programs.
3. Ensure all bridges in the state are inspected at a frequency and by a method consistent with the NBIS and state law.
4. Ensure that bridge inspection data is uploaded to BIAS within mandated time frames and that all required files have been uploaded into ERMS.
5. Ensure load ratings are completed in accordance with all federal requirements.
6. Oversee quality assurance and quality control of all bridge inspection programs.
7. Coordinate with federal, state, toll road, county, and local governmental agencies.
8. Formulate and monitor in-depth inspection programs for bridges with fracture critical members, underwater components, or unique or special features requiring additional attention during inspection to assure the safety of such structures.
9. Conduct annual inspections of state border bridges in company with respective states' personnel and district offices to determine required actions and lead the effort to accomplish Indiana's portion of any required actions.
10. Notify FHWA of all critical findings within 24 hours.

BRIDGE INSPECTION MANUAL

PART 1: ADMINISTRATION

11. Ensure proper signage is in place for bridges that require load posting or other restrictions.
12. Ensure a system is in place that will notify INDOT BIE and BIC of required inspections and their due dates.
13. Ensure a system is in place to upload all approved inspection data.
14. Formulate and administer programs and policies.
15. Develop, implement, and evaluate inspection and preservation policies, standards, procedures, and programs.
16. Analyze federal and state legislation, administrative rules, and national and industry standards for incorporation in programs and policies.
17. Recommend the revision of legislation and participate in new legislation development.
18. Lead prompt, decisive, and effective responses to emergencies such as floods, earthquakes, and major bridge damage.
19. Train bridge inspection personnel.
20. Develop, monitor, and update training programs for state and consultant inspectors.
21. Arrange or conduct inspection training programs and refresher programs throughout the state.
22. Provide training on proper access, equipment operation, and safety procedures.
23. Review and approve Approved Team Leader and Approved Team Member qualifications. The SPM will have the final say on all questions of qualifications.
24. Maintain a list of all qualified Approved Team Leaders and Approved Team Members in Indiana. The list will identify training required to keep the qualifications up to date.
25. Evaluate Approved Team Leaders and Approved Team Members and require additional training, as necessary.
26. Advise on technical issues concerning problems or deficiencies discovered during inspections.
27. Act as an Approved Team Leader as needed.
28. Monitor inspections and develop a good, general knowledge of all bridges in the state and their inspection records.
29. Review all inspection reports for complex bridges performed on Indiana bridges.
30. Manage state bridge inspection personnel and consultants to meet the needs of the State Bridge Inspection Program.

BRIDGE INSPECTION MANUAL

PART 1: ADMINISTRATION

31. Manage state-owned under-bridge access equipment to assist in the inspection of bridges statewide.

1-1.04(02) Assistant State Program Manager ASPM-R&P) – Rating & Posting

The ASPM-R&P is responsible for setting all bridge load rating and posting policies and procedures for all bridges in the state.

ASPM-R&P Minimum Qualifications

The ASPM must meet the following minimum qualifications:

1. Capable of overseeing the load rating and posting of all public bridges in the state.
2. Registered Professional Engineer (PE) in the state of Indiana.

ASPM-R&P Responsibilities

The Assistant State Program Manager (ASPM-R&P) is charged with the overall responsibility for load rating and posting of bridges in the state.

1-1.04(03) Assistant State Program Manager (ASPM-BI&I) – Bridge Inspection & Inventory

The ASPM-BI&I is responsible for assisting the SPM and to help ensure that NBI Data is being collected in a timely manner and stored in the Bridge Files properly, and reported to the FHWA as required.

ASPM- BI&I Minimum Qualifications

The ASPM must meet the following minimum qualifications:

1. Capable of overseeing the INDOT Bridge Inspection Engineers (BIE), all Bridge Inspection Consultants (BIC)
2. Sound background in bridge inspection
3. Specialized knowledge and skills in bridge design, construction, soils, construction materials, and emergency repair techniques
4. Successful completion of the Safety Inspection of In-Service Bridges (FHWA-NHI-130055) course or Safety Inspection of In-Service Bridges for Professional Engineers (FHWA-NHI-130056)
5. Successful completion of the Fracture Critical Inspection Techniques for Steel Bridges (FHWA-NHI-130078) course
6. Registered Professional Engineer (PE) in the state of Indiana.

BRIDGE INSPECTION MANUAL

PART 1: ADMINISTRATION

ASPM- BI&I Responsibilities

The responsibilities of this position are:

1. Assist the INDOT BIE, all Inspection Consultants with data and data base issues.
2. Assist the SPM to manage the statewide bridge inspection and inventory programs.
3. Assist BIAE to ensure all bridges in the state are inspected at a frequency and by a method consistent with the NBIS and state law.
4. Assist BIAE to ensure bridge inspection data is uploaded to BIAS within mandated time frames and that all required files have been uploaded into ERMS.
5. Assist BIAE to oversee quality assurance and quality control of all bridge inspection data.
6. Assist with the coordination with federal, state, toll road, county, and local governmental agencies.
7. Participate on the annual inspections of state border bridges in company with respective states' personnel and district offices to determine required actions and lead the effort to accomplish Indiana's portion of any required actions.
8. Continuously review the status of all critical findings and recommend to the SPM those that can be closed out.
9. Review the NBI Data monthly to ensure that all INDOT BIE and BIC have access to the latest information on all required inspections and their due dates.
10. Ensure the database to upload all approved inspection data is functioning properly.
11. Assist the SPM to formulate and administer programs and policies.
12. Assist the SPM to develop, implement, and evaluate inspection and preservation policies, standards, procedures, and programs.
13. Assist the SPM to analyze federal and state legislation, administrative rules, and national and industry standards for incorporation in programs and policies.
14. Assist the SPM to lead prompt, decisive, and effective responses to emergencies such as floods, earthquakes, and major bridge damage.
15. Assist the BIEA and CIE to train bridge inspection personnel, especially on the use of the database.
16. Assist the SPM to develop, monitor, and update training programs for state and consultant inspectors.
17. Assist the SPM to arrange or conduct inspection training programs and refresher programs throughout the state.

BRIDGE INSPECTION MANUAL

PART 1: ADMINISTRATION

18. Review and approve Approved Team Leader and Approved Team Member qualifications. The SPM will have the final say on all questions of qualifications.
19. Assist to maintain a list of all qualified Approved Team Leaders and Approved Team Members in Indiana. The list will identify training required to keep the qualifications up to date.
20. Assist with the evaluation of Approved Team Leaders and Approved Team Members and require additional training as necessary.
21. Advise on technical issues concerning problems or deficiencies discovered during inspections.
22. Act as an Approved Team Leader as needed.
23. Monitor inspections and develop a good, general knowledge of all bridges in the state and their inspection records.
24. Review all inspection reports for complex bridges performed on Indiana bridges.
25. Other duties as assigned by the SPM

1-1.04(04) Bridge Inspection Area Engineer (BIAE)

The BIAE is responsible for assisting the SPM and ASPM-BI&I as directed, to help develop bridge inspection policies and procedures, and for ensuring all bridge and large culverts inspections in their areas of oversight are conducted on time and to the proper level of quality, by assisting the District Bridge Inspection Supervisors. They shall be responsible for conducting statewide Quality Assurance (QA).

INDOT BIAE Minimum Qualifications

The BIAE will meet the following minimum qualifications:

1. Capable of overseeing the INDOT BIE
2. Sound background in bridge inspection
3. Specialized knowledge and skills in bridge design, construction, soils, construction materials, and emergency repair techniques
4. Successful completion of FHWA-NHI-130055, Safety Inspection of In-Service Bridges or FHWA-NHI-130056, Safety Inspection of In-Service Bridges for Professional Engineers
5. Successful completion of FHWA-NHI-130078, Fracture Critical Inspection Techniques for Steel Bridges
6. Registered PE in the state of Indiana

BRIDGE INSPECTION MANUAL

PART 1: ADMINISTRATION

BIAE Responsibilities

As a part of the responsibilities of this position, the BIAE shall:

1. Oversee INDOT BIE.
2. Assist the ASPM-R&P, to ensure that state and county bridge postings and restrictions are in place and done so in a timely manner.
3. Ensure proper signage is in place for bridges that require load posting or other restrictions.
4. Ensure that the District Bridge Inspection Supervisors and all INDOT BIE and BIC of know how to determine which structures have upcoming inspections and their inspection due dates.
5. Ensure that the District Bridge Inspection Supervisors have properly trained their personnel on how to use the inspection database on their computers and I-pads and are able to upload all approved inspection data.
6. Develop, implement, and evaluate inspection and preservation policies, standards, procedures, and programs.
7. Analyze federal and state legislation, administrative rules, and national and industry standards for incorporation in programs and policies.
8. Recommend the revision of legislation and participate in new legislation development.
9. Lead prompt, decisive, and effective responses to emergencies such as floods, earthquakes, and major bridge damage.
10. Train bridge inspection personnel.
11. Develop, monitor, and update training programs for state and consultant inspectors.
12. Arrange or conduct inspection training programs and refresher programs throughout the state.
13. Provide training on proper access, equipment operation, and safety procedures.
14. Assist in the evaluation of Approved Team Leaders and Approved Team Members as to possible upgrades in their status and recommend additional training to help upgrade inspectors.
15. Advise on technical issues concerning problems or deficiencies discovered during inspections.
16. Act as an Approved Team Leader as needed.
17. Monitor inspections and develop a good, general knowledge of all bridges in the state and their inspection records.

BRIDGE INSPECTION MANUAL

PART 1: ADMINISTRATION

18. Review all inspection reports for complex bridges performed on Indiana bridges.
19. Conduct Quality Assurance Reviews on both State and Local Bridge Inspections.
20. Work with the SPM to address all issues found by the FHWA during their annual NBIS Program Review.

1-1.04(05) I N D O T Bridge Inspection Engineer (BIE)

The INDOT BIE is responsible for the inspection and reporting for all assigned state-owned bridges.

INDOT BIE Minimum Qualifications

The INDOT BIE must meet the following qualifications:

1. Successful completion of FHWA-NHI-130055, Safety Inspection of In-Service Bridges or FHWA-NHI-130056 Safety Inspection of In-Service Bridges for Professional Engineers
2. Qualified as a Bridge Approved Team Leader in the state of Indiana
3. Registered PE in the state of Indiana with appropriate training and experience
4. Capable of overseeing Approved Team Leaders and Approved Team Members
5. Successful completion of FHWA-NHI-130078, Fracture Critical Inspection Techniques for Steel Bridges
6. Demonstrate a strong background in such areas as structural engineering, structural behavior trends, and bridge rehabilitation techniques
7. Demonstrate management abilities
8. Demonstrate thorough familiarity with NBIS, this manual, and applicable INDOT guideline
9. Good eyesight and the ability to walk and climb over uneven surfaces and be comfortable working at heights, near water, in confined spaces, and close to live traffic

BIE Responsibilities

As a part of the responsibilities of this position, the INDOT BIE shall:

1. Coordinate inspections to ensure that all inspections are completed in compliance with this manual.
2. Oversee Approved Team Leaders and Approved Team Members.
3. Ensure that all assigned state-owned bridge inspection results are approved and uploaded to BIAS within 60 days of the date of the inspection and within seven days for all closures and emergency inspections.

BRIDGE INSPECTION MANUAL

PART 1: ADMINISTRATION

4. Notify the SPM of all critical findings in accordance with Section 4.02.
5. Act as an Approved Team Leader as needed.

1-1.04(06) Bridge Inspection Consultant (BIC)

The BIC is the individual in a prequalified consulting firm who is responsible for all contracted inspections. This may be the same individual in the Firm that has been designated as the BIAS Administrator. The firm that this person works for may be hired by INDOT and working on INDOT Bridges, and/or hired by a County or the Indiana Toll Road and working on local or Toll Road Bridges. The firms may have multiple Approved Team Leaders or Team Members however the BIC is the Inspector responsible for the contracted work and is usually the contact person for the SPM to discuss issues on inspection work for the firm.

BIC Minimum Qualifications

The BIC must meet the following minimum qualifications:

1. Registered PE in the state of Indiana with appropriate training and experience
2. Qualified as an Approved Team Leader in the state of Indiana.
3. Successful completion of FHWA-NHI-130055, Safety Inspection of In-Service Bridges or FHWA-NHI-130056, Safety Inspection of In-Service Bridges for Professional Engineers
4. Successful completion of FHWA-NHI-130078, Fracture Critical Inspection Techniques for Steel Bridges
5. Capable of overseeing ATL and ATM
6. If this person is the BIAS administrator for the Firm, then this person must have had BIAS Administrative training from INDOT.

BIC Responsibilities

As a part of the responsibilities of this position, the BIC shall:

1. Oversee ATL and ATM at his Firm and provide Access to and Training for BIAS.
2. Accept responsibility for all contracted inspections.
3. Inspect or ensure that qualified inspectors inspect all bridges and large culverts included in their contracts in compliance with this manual.
4. Ensure that all inspection results are approved and uploaded to BIAS within 60 days of the of the inspection date and within seven days for all closures and emergency inspections.
5. Ensure that all quality control and quality assurance procedures are met for all team leaders.
6. Fulfill requests for information from the SPM in an efficient and timely manner.

BRIDGE INSPECTION MANUAL

PART 1: ADMINISTRATION

7. Recommend load posting, restrictions, or bridge closings and ensure the related signage is in compliance with the applicable requirements.
8. Notify the SPM of all critical findings in accordance with Section 4.02.
9. Assist INDOT in maintaining an accurate and up to date inventory of all bridges and large culverts in BIAS.
10. Recommend a bridge repair and construction program to the agency.
11. Ensure all ATL, ATM, LRE, and General User active profiles are maintained in good standing in BIAS. The list shall include the following:
 - a. Name
 - b. Company Name
 - c. Address
 - d. Email Address
 - e. Phone Number
 - f. Training Course Certificates
 - g. Professional Engineering License
 - h. Other Pertinent Certifications; SPRAT, Commercial Diver, Confined Space, etc.

1-1.04(07) Approved Team Leader (ATL)

The ATL is the person responsible for the field inspection work. Preferably, the inspection team should consist of two persons: an ATL and an Approved Team Member (ATM).

ATL Minimum Requirements

The ATL must meet the following requirements to be considered qualified:

1. Be responsible for field work and be on site during the inspection
2. Demonstrate a strong background in such areas as structural engineering, structural behavior trends, and bridge rehabilitation techniques
3. Demonstrate management abilities
4. Thorough familiarity with all NBIS, this manual, and applicable INDOT guideline
5. Good eyesight, the ability to walk and climb over uneven surfaces, and the ability to work at heights, near water, in confined spaces, and close to live traffic
6. Meet one of the following scenarios:

BRIDGE INSPECTION MANUAL

PART 1: ADMINISTRATION

- a. Successful completion of FHWA-NHI-130055, Safety Inspection of In-Service Bridges, or FHWA-NHI-130056 Safety Inspection of In-Service Bridges for Professional Engineers **and** Registered PE in the state of Indiana
 - b. Successful completion of FHWA-NHI-130055 and Bachelor degree in Engineering from a college or university accredited by the Accreditation Board for Engineering and Technology or a substantially equivalent organization, **and** successful completion of the National Council of Examiners for Engineering and Surveying Fundamentals of Engineering exam, **and** two years of bridge inspection experience in a responsible capacity under the direction and supervision of a qualified ATL
 - c. Successful completion of FHWA-NHI-130055 and five years of Bridge Inspection Experience in a responsible capacity under the direction and supervision of a qualified ATL. The predominate amount of bridge inspection experience, or more than fifty percent, should come from NBIS bridge safety inspection experience. Other experience in bridge design, bridge maintenance, or bridge construction may be used to provide the additional required experience, at the approval of the SPM.
 - d. Successful completion of FHWA-NHI-130055 **and** Certified Level III or IV NICET Bridge Inspector.
 - e. Successful completion of FHWA-NHI-130055 **and** Associate's degree in Engineering or Engineering Technology from a college or university accredited by the Accreditation Board for Engineering and Technology or by a substantially equivalent organization, **and** four years of bridge inspection experience in a responsible capacity, as determined by the SPM, under the direction and supervision of a qualified ATL.
7. Complete the On-line Critical Finding Course
- a. All Approved Team Leaders (ATL) are required to complete and pass the On-Line Critical Finding Course through the INDOT Training Portal. Newly certified bridge inspection team leaders shall complete and pass this course within 60 calendar days of becoming an ATL.
 - b. The certificate acquired upon successful completion shall be uploaded by the ATL into the ATL's BIAS User Account into a folder titled "INDOT Courses". Once the certificate is uploaded to the ATL's BIAS User Account, the ATL shall send an email to the BIAS Administrator at INBridgesHelp@indot.in.gov confirming that the requirement has been completed in the prescribed time frame to maintain a valid "Approved Team Leader" status.
 - c. This course and certification shall be completed and passed no later than 45 calendar days following the date of this memorandum. In addition, this course and certification shall be renewed biennially to maintain a valid Approved Team Leader status.

BRIDGE INSPECTION MANUAL

PART 1: ADMINISTRATION

- d. The course should take approximately 60 minutes to complete. Successful completion of the course provides 1 Professional Development Hour (PDH) credit

To remain qualified, all Approved Team Leaders:

1. Must successfully complete Bridge Inspection Refresher Training (FHWA-NHI-130053) or FHWA-NHI-130055/130056 at least once every 10 years.
2. Must have conducted a bridge inspection, where he/she has fully participated in the field inspection work and signed his/her name on the report in the last five years. Approved Team Leaders who do not meet this requirement must successfully complete FHWA-NHI- 130053 - Bridge Inspection Refresher Training to become re-qualified.
3. Maintain a current S-BRITE Bridge Inspection certification. The requirements to acquire and maintain the bridge inspection certification from the Purdue University Steel Bridge Research, Inspection, Training, and Engineering Center will be published in Bridge Inspection Memorandums and may also be found at the S-BRITE link: <https://engineering.purdue.edu/CAI/SBRITE/Training>.

The Approved Team Leader who does not meet the ongoing qualifications outlined may conduct field inspections during an emergency such as a flood, post-earthquake, or after a collision. He/she must be instructed by, and under the supervision of, a qualified Approved Team Leader. The inspections should be limited and should not involve changing any NBI data without having their data reviewed by a qualified Approved Team Leader.

1-1.04(08) Complex Bridge Approved Team Leader

Approved Team Leader for the inspection of a complex bridge is not a separate team leader classification. A complex bridge inspection is not a separate type of bridge inspection. A complex bridge inspection will follow the instructions outlined in the inspection plan, for the individual complex bridge. This complex inspection plan shall be in saved in BIAS, so it is easy to find and review. The inspection plan will outline the experience and skills necessary to perform the complex bridge inspection. The selection of a complex team leader will be based on experience and specific engineering qualifications for the specific complex bridge. A complex bridge may require engineering expertise in areas such as structural, mechanical, and electrical. The specific requirements will be listed in the design level three requirements of contract documents if contracted and the inspection plan. The team leader managing the multidisciplinary engineering specialties must meet the following requirements:

1. Qualified Approved Team Leader
2. Successful completion of FHWA-NHI-130078, Fracture Critical Inspection Techniques for Steel Bridges.
3. Licensed Professional Engineer in the state of Indiana and have specific experience on the type of complex bridge being inspected and have qualified team members to cover all necessary engineering disciplines to inspect all components of the complex structure.

BRIDGE INSPECTION MANUAL

PART 1: ADMINISTRATION

4. Current certification from Purdue University Steel Bridge Research, Inspection, Training and Engineering Center.
5. The credentials must be approved by the SPM.

1-1.04(09) Fracture Critical Approved Team Leader (ATL-F)

ATL-F Minimum Requirements

Approved Team Leaders for the inspection of a fracture critical bridge must meet the following requirements:

1. Qualified Approved Team Leader
2. Successful completion of FHWA-NHI-130078.
3. Licensed Professional Engineer in the state of Indiana or have 2 additional years of bridge inspection experience as a team leader.
4. Current certification from Purdue University Steel Bridge Research, Inspection, Training and Engineering Center.
5. The credentials must be approved by the SPM.

1-1.04(10) Underwater Approved Team Leader (ATL-U)

ATL-U Minimum Requirements

An Approved Team Leader for an Underwater Inspection will meet the following requirements:

1. Qualified Approved Team Leader
2. Divers must meet the requirements listed in Section 1.04(13)
3. Registered PE licensed in the State of Indiana
4. Experienced in Underwater and In-Water Bridge inspections
5. Experienced in stream bed profiles and cross sections
6. Experienced in underwater nondestructive testing techniques
7. Responsible for the inspection, data integrity, and report preparation for bridge inspection projects in the last five years

BRIDGE INSPECTION MANUAL

PART 1: ADMINISTRATION

ATL-U Responsibilities

The Approved Team Leader shall:

1. Lead the inspection team in actively planning, preparing, and performing bridge inspections. The ATL-U must be at the bridge at all times during the inspection.
2. Be on site leading in the inspection of each bridge and participating in all in-water activities.
3. Ensure worksite safety compliance, including traffic control, waterway control where needed, Inspection Team Members' safety procedures, equipment, and the proper use of access equipment.
4. Sign each bridge inspection report and take full responsibility for all data and comments contained in the report.
5. Approve all data in BIAS.
6. Train Inspection Team Members working under his/her supervision and provide opportunities to further his/her knowledge and professionalism in this field.
7. Report any condition which is dangerous to persons or property, or any structural condition that would likely increase the potential for structure or member failure, to the SPM and the INDOT BIE or BIC as soon as possible.
8. Report any Critical findings to the appropriate individuals and agencies identified in 1-4.02.
9. Recommend load posting calculations be completed as needed.
10. Recommend restrictions or bridge closings and ensure the related signage is following all applicable requirements.
11. Duties and responsibilities of the Approved Team Leader are described in 1-1.04(05).
12. Clearly document in the report, all areas that were not able to be inspected fully, due to drift/debris build-up.

1-1.04(11) Approved Team Member (ATM)

ATM Minimum Requirements

An ATM shall meet, as a minimum, all the qualifications listed below:

1. High School Degree or equivalent
2. Familiarity with NBIS
3. Familiarity with the FHWA Recording and Coding Guide
4. Familiarity with appropriate parts of this manual

The Approved Team Member is encouraged to take FHWA-NHI-130055, Safety Inspection of In-Service Bridges.

BRIDGE INSPECTION MANUAL

PART 1: ADMINISTRATION

ATM Responsibilities

The Approved Team Member is responsible for the following:

1. Following all Approved Team Leader instructions in a safe manner
2. Assisting the Approved Team Leader in the field
3. Documenting his/her participation and experience
4. Keeping a personal log of bridge inspection and related bridge experience
5. Acting in a professional manner
6. Studying to take and pass Bridge Inspection Training Class (FHWA-NHI-130055)

1-1.04(12) Nondestructive Testing Specialists

Individuals contracted to perform nondestructive testing (NDT) shall be qualified in accordance with American Society for Nondestructive Testing (ASNT) Level II or III, or as called for in any bridge inspection contract. For all NDT work, other than dye penetrate, the NDT personnel must work hand-in-hand with a professional engineer, licensed in Indiana, who is qualified as a Bridge Approved Team Leader.

1-1.04(13) Divers

Diving operations shall be conducted in accordance with all applicable federal and state regulations. Each member of the team should be trained in accordance with Occupational Safety and Health Administration (OSHA) standards.

All divers shall have completed training accredited by the Association of Commercial Diving Educators to the appropriate level or documented evidence that the divers training meets the requirements specified by the national consensus standard published by the American National Standards Institute (ANSI) and the Association of Commercial Diving Educators (ACDE) (i.e. ANSI / ACDE-01-2015, American National Standard for Divers – Commercial Diver Training – Minimum Standard).

All divers shall have certification proving successful completion of the Underwater Bridge Inspection course (FHWA-NHI-130091). All proof of training and certifications must be on file in the BIAS Account of the individual.

1-1.04(14) Load Rating Engineer (LRE)

Routine load ratings of state-owned bridges are generally performed and maintained by INDOT's Bridge Load Rating Engineer in the Division of Bridges. The load rating of toll road, county, and local bridges is generally done by the BIC of record for owner.

BRIDGE INSPECTION MANUAL

PART 1: ADMINISTRATION

LRE Minimum Qualifications

The LRE must meet the qualifications listed below:

1. Have experience calculating load ratings and knowledge of load capacity rating computer programs and posting policies in Indiana. A list containing (15-20) bridges load rated along with the rating methods/programs used and the condition of the bridges (new/deteriorated) must be in the person's BIAS Account, in order to be considered as a LRE
2. Registered PE licensed in the state of Indiana, qualified to oversee, review, and certify all load capacity ratings performed under his/her supervision
3. It is preferred, but not required, that the LRE successfully complete FHWA-NHI-130055, Safety Inspection of In-Service Bridges.

LRE Responsibilities

The LRE must:

1. Provide engineering judgment to those performing the load ratings.
2. Be actively involved in reviewing the quality and accuracy of all load ratings.

1-1.05 Bridge Inspection Database

INDOT's Bridge Inspection Database is called BIAS (Bridge Inspection Application System). This application is used to create the annual file submitted to Federal Highway.

All inspection data shall be entered into BIAS and approved by the Approved Team Leader.

These materials include the following:

1. Structure Inventory and Appraisal information
2. Field inspection information including sketches and photographs showing typical and deteriorated conditions. This requirement includes a brief narrative to justify a change in condition rating. An NBI item rated below 5 or condition state 3 requires a picture or sketch in addition to narrative descriptions of the deteriorated condition. A plan of action is to be included if required.
3. Critical Findings in accordance with Section 1-4.02
4. Waterway information in accordance with Section 1-2.12
5. Other Inspection Procedures. These items will include other required reports such as fracture critical and underwater. These reports will be in accordance with Section 1-2.0 of this manual.
6. Load Rating. A dated load rating along with identification of the analysis to determine capacity. Results must be included which clearly identify the loads and methodology used in the analysis. Identify controlling members. Include any updates that reflect changes in the condition of structural members. If calculations cannot be provided due to lack of

BRIDGE INSPECTION MANUAL

PART 1: ADMINISTRATION

information, provide documentation for justification of determined load rating.

7. Posting Documentation. In accordance with 3-9.02(02)
8. Scour Assessment. Document the assessment conducted to determine the scour vulnerability of the bridge.

For additional information on BIAS and ERMS requirements see section 1-3.0 Reporting Systems

BRIDGE INSPECTION MANUAL

PART 1: ADMINISTRATION

FIGURES

[1-1.1: Bridge Structure Measurements](#)

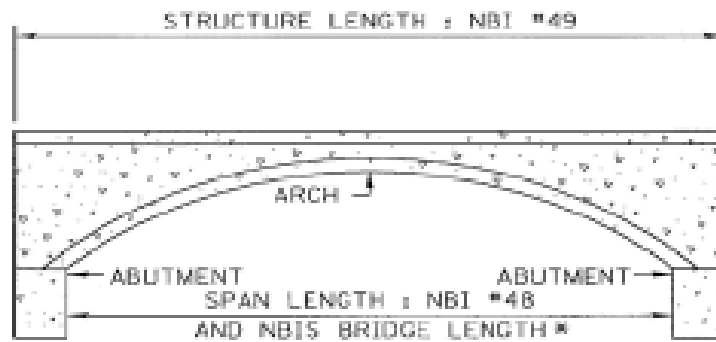
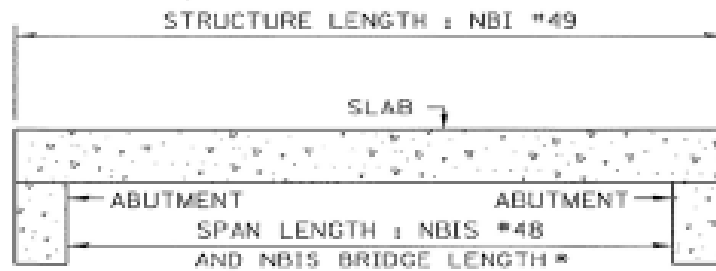
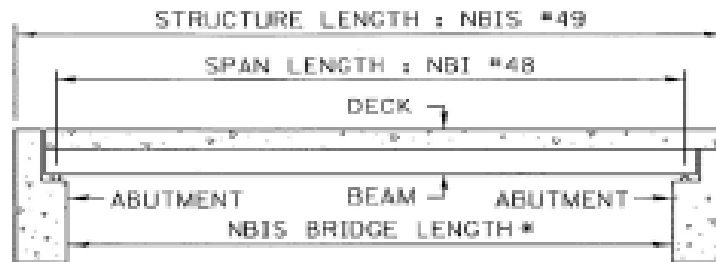

* IF GREATER THAN 20 FEET
NBIS #112 = Y

BRIDGE INSPECTION MANUAL

PART 1: ADMINISTRATION

BRIDGE INSPECTION MANUAL

PART 1: ADMINISTRATION

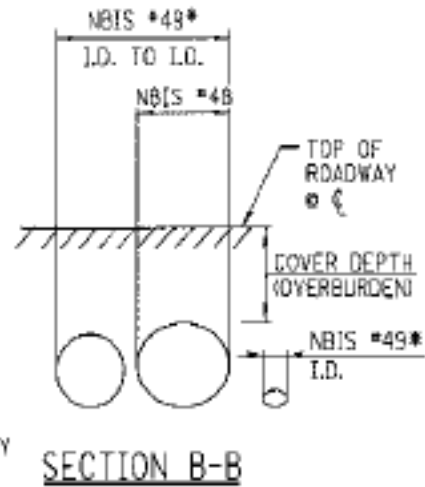
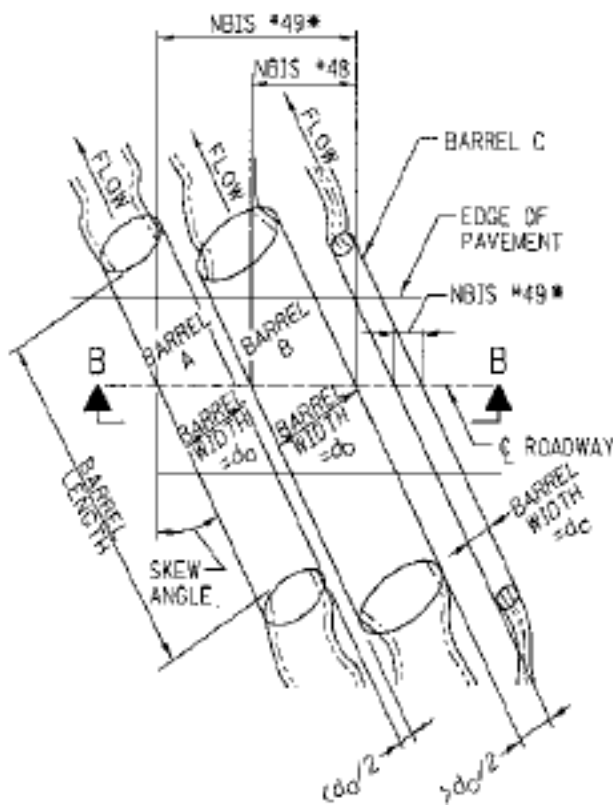
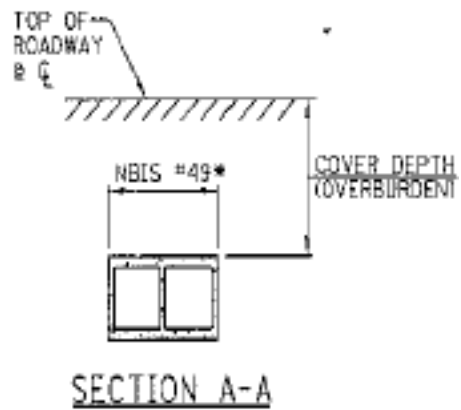
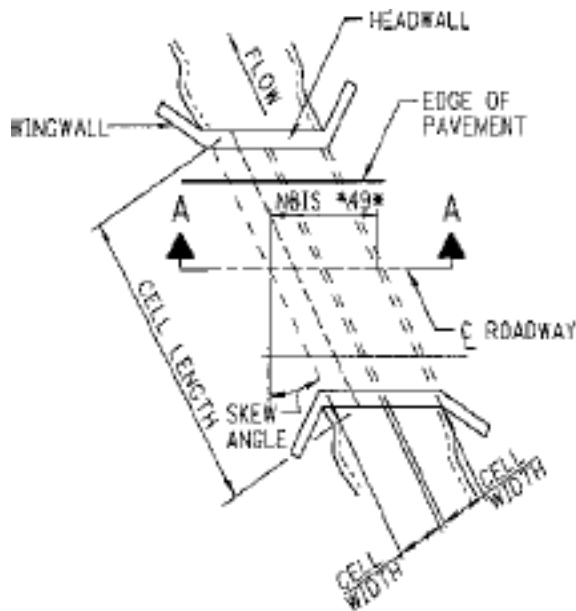

* IF GREATER THAN 20 FEET
NBIS #112 = Y

[1-1.2: State Bridge Inspection Program Organization](#)

BRIDGE INSPECTION MANUAL

PART 1: ADMINISTRATION

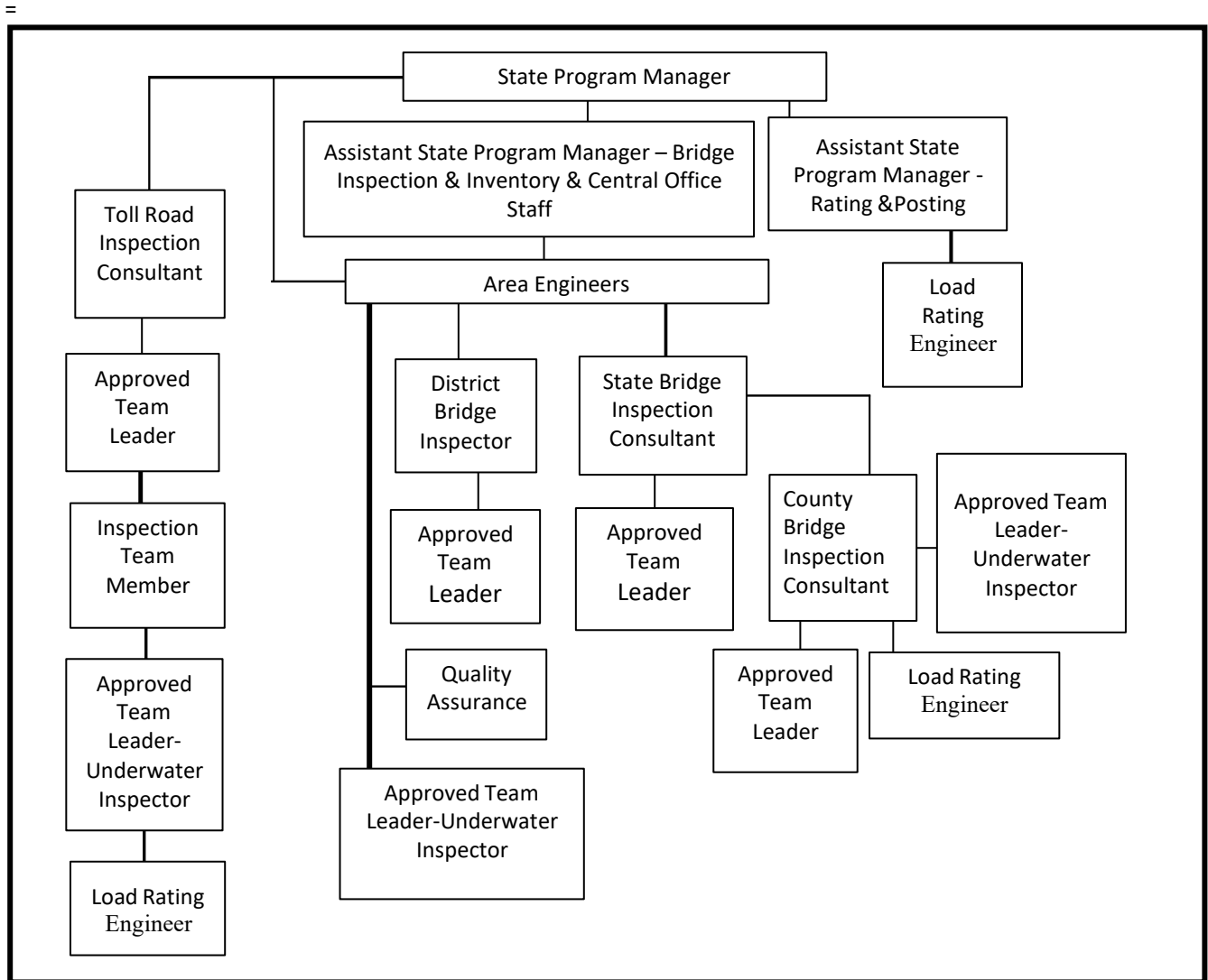

[1-1.3: Bridge Inspection Positions](#)

BRIDGE INSPECTION MANUAL

PART 1: ADMINISTRATION

| Inspection Positions | BIAS Abbreviation | Manual Section |
|---|----------------------|-------------------|
| State Program Manager | SPM | 1-1.04(01) |
| Assistant State Program Manager - Load Rating & Posting | ASPM-R&P | 1-1.04(02) |
| Assistant State Program Manager - Bridge Inspection & Inventory | ASPM-BI & I | 1-1.04(03) |
| Bridge Inspection Area Engineer | BIAE | 1-1.04(04) |
| INDOT Bridge Inspection Engineer | BIE | 1-1.04(05) |
| Bridge Inspection Consultant | BIC | 1-1.04(06) |
| Approved Team Leader | ATL | 1-1.04(07) |
| Complex Bridge Approved Team Leader | ~ | 1-1.04(08) |
| Fracture Critical Approved Team Leader | ATL-F | 1-1.04(09) |
| Underwater Approved Team Leader- | ATL-U | 1-1.04(10) |
| Approved Team Member | ATM | 1-1.04(11) |
| Nondestructive Testing Specialists | ~ | 1-1.04(12) |
| Divers | ~ | 1-1.04(13) |
| Load Rating Engineer | LRE | 1-1.04(14) |

INDOT BRIDGE INSPECTION MANUAL

PART 2

TYPES OF INSPECTIONS

BRIDGE INSPECTION MANUAL

PART 2: TYPES OF INSPECTIONS

TABLE OF CONTENTS

| | |
|---|----------|
| LIST OF FIGURES..... | 3 |
| 2-2.0 TYPES OF INSPECTIONS..... | 4 |
| 2-2.01 Introduction | 4 |
| 2-2.01(01) Timely Inspections..... | 4 |
| 2-2.01(02) Delinquent Inspections..... | 4 |
| 2-2.02 Inspection Types..... | 5 |
| 2-2.03 Inspection Schedules..... | 5 |
| 2-2.04 Inspection Plan of Action..... | 6 |
| 2-2.05 Initial Inspections..... | 6 |
| 2-2.05(01) Purpose | 6 |
| 2-2.05(02) Precision | 7 |
| 2-2.05(03) Repairs | 8 |
| 2-2.05(04) Frequency..... | 8 |
| 2-2.06 Routine Inspection | 8 |
| 2-2.06(01) Purpose | 8 |
| 2-2.06(02) Precision | 8 |
| 2-2.06(03) Inspection Frequency..... | 10 |
| 2-2.06(04) Extended Inspection Frequency..... | 10 |
| 2-2.07 Fracture Critical Inspections..... | 13 |
| 2-2.07(01) Purpose | 13 |
| 2-2.07(02) Frequency..... | 13 |
| 2-2.08 Underwater Inspections..... | 13 |
| 2-2.08(01) Purpose | 13 |
| 2-2.08(02) P r e c i s i o n | 14 |
| Level I Effort..... | 16 |
| Level II Effort..... | 16 |
| Level III Effort | 16 |
| 2-2.08(03) F r e q u e n c y | 17 |
| 2-2.09 Special Inspections..... | 17 |
| 2-2.09(01) P u r p o s e | 18 |

BRIDGE INSPECTION MANUAL

PART 2: TYPES OF INSPECTIONS

| | |
|--|-----------|
| 2-2.09(02) <i>Precision</i> | 18 |
| 2-2.09(03) <i>Frequency</i> | 20 |
| 2-2.10 In-Depth Inspection..... | 21 |
| 2-2.10(01) <i>Purpose</i> | 21 |
| 2-2.10(02) <i>Precision</i> | 21 |
| 2-2.10(03) <i>Frequency</i> | 21 |
| 2-2.11 Damage Inspections..... | 21 |
| 2-2.11(01) <i>Purpose</i> | 21 |
| 2-2.11(02) <i>Precision</i> | 22 |
| 2-2.11(03) <i>Frequency</i> | 22 |
| 2-2.12 Channel Surveys | 23 |
| 2-2.12(01) <i>Purpose</i> | 23 |
| 2-2.12(02) <i>Precision</i> | 23 |
| 2-2.12(03) <i>Frequency</i> | 25 |
| 2-2.13 Large Culvert Inspection | 26 |
| 2-2.13(01) <i>Purpose</i> | 26 |
| 2-2.13(02) <i>Precision</i> | 26 |
| 2-2.13(03) <i>Frequency</i> | 27 |
| 2-2.14 Bridges Closed To Traffic | 27 |
| 2-3.0 REPORTING SYSTEMS | 28 |
| 2-3.01 Bridge File..... | 28 |
| 2-3.02 Structure Identification | 32 |
| 2-3.02(01) <i>NBI Item 8 Structure Number</i> | 32 |
| 2-3.02(02) <i>INDOT Bridge Number</i> | 32 |
| 2-3.02(03) <i>Toll Road Bridge Numbers</i> | 34 |
| 2-3.02(04) <i>County and Local Agency Bridge Numbers</i> | 35 |
| 2-3.03 Inside Indiana - County Border Inventory..... | 35 |
| 2-3.04 State Line - County Border Inventory..... | 35 |
| 2-4.0 EMERGENCY NOTIFICATION/CRITICAL FINDINGS | 36 |
| 2-4.01 Introduction | 36 |
| 2-4.02 Critical Findings..... | 36 |
| 2-4.02(01) <i>Procedures for Inspectors</i> | 37 |

BRIDGE INSPECTION MANUAL

PART 2: TYPES OF INSPECTIONS

| | |
|--------------------------------|-----------|
| 2-4.02(02) Documentation | 38 |
| FIGURES..... | 38 |

LIST OF FIGURES

| <u>FIGURES</u> | <u>TITLE</u> |
|----------------|---|
| 2-1.1: | Bridge Inspection Types and Maximum Intervals |
| 2-1.2: | Summary of Underwater Inspection - Intensity Levels |
| 2-1.3: | Creating a Report in BIAS |
| 2-1.4: | Requesting Access |

BRIDGE INSPECTION MANUAL

PART 2: TYPES OF INSPECTIONS

2-2.0 TYPES OF INSPECTIONS

2-2.01 Introduction

There are numerous types of inspections, each designed to obtain specific information. For example, an Initial Inspection is performed after a bridge is constructed to document the as-built conditions, whereas Routine Inspections are used to monitor the condition of a bridge at regular intervals. Damage Inspections are used to assess damage resulting from deterioration or events such as impacts, fires, or floods. These inspections help create a complete picture of a bridge's condition and are described in detail in this chapter.

Visual inspection is the primary examination method for all inspections. Nondestructive testing (NDT) techniques may be required to identify internal flaws or hard-to-see external defects in critical members.

2-2.01(01) Timely Inspections

As a minimum, prior to the end of the month for timely inspections being performed, the inspector will revise item 90 to reflect the date the inspection was performed. At the beginning of the following month, the BIAS Administrator will verify the revision to item 90. The inspector will submit and approve the final report in BIAS within 60 days. Inspectors failing to meet these requirements will be subject to certification review. At the beginning of the third month following the inspection, the BIAS Administrator will verify that the final inspection report is complete and has been properly approved in BIAS. These inspection quality reviews are required for INDOT to be in compliance with Federal Highway metrics.

2-2.01(02) Delinquent Inspections

An inspection is considered delinquent when the inspection interval exceeds the required interval. If an inspection cannot be completed on time, the inspection team leader must notify the INDOT Bridge Inspection Manager prior to exceeding the inspection interval. That notice will include the Delinquent Inspection form located in BIAS under the Help tab in the documentation folder. The document is labeled "How to complete a Delinquent Inspection Form" The form is attached to the bottom of the instructions. See Appendix 2A

BRIDGE INSPECTION MANUAL

PART 2: TYPES OF INSPECTIONS

2-2.02 Inspection Types

The Federal Highway Administration (FHWA) and the state of Indiana dictate the type of inspection each bridge requires, and the maximum interval between inspections. Figure [2-2.1: Bridge Inspection Types and Maximum Intervals](#) gives an overview of the types of inspections, the maximum interval between inspections, and the governmental unit responsible for the inspection policy.

2-2.03 Inspection Schedules

Once a Routine Inspection has been conducted on a bridge, the following Routine Inspections and other scheduled inspections should be completed in the same month unless the SPM approves changing the frequency. A scheduled inspection can be conducted early but must never be conducted late.

County Bridges have been assigned a “Compliance Month” or “Months” to help ensure that all inspections are done on time and are not spread out over too long of a period.

The BIAS *Scheduler* is one way to identify the next scheduled inspection for each inspection type. The *Scheduler* as well as NBI Item 90 and 91 will be a component of BIAS data reported to FHWA regarding the execution of on-time and future required inspections.

Upon final approval of any inspection type, the *Scheduling* fields will be reviewed on the primary Inspection Report Information page. All report type schedules will be maintained.

The Due Date and Schedule Date is calculated based on the last approved inspection of that type and can only be edited after the inspection report has been uploaded and approved in BIAS.

If a Schedule needs modified following the upload and report approval, the Scheduling tab should be used.

In addition to the use of the *Scheduler*, a “Compliance Month” field has been added to the MAD2 tab within the Asset Values for each county-owned bridge asset. The field has been populated with the compliance month. Compliance month data can be modified only by the INDOT BIAS Administrator.

The Inspection Schedule Filter: All Overdue Bridge Inspection Reports will be the basis for monthly/quarterly reporting for FHWA for compliance for all inspection frequencies for all inspection types: routine, special, fracture critical and underwater.

BIAS Admins and the BIAS Administrator will assist by providing periodic review of the data and informing inspectors when corrections to the scheduler are necessary.

BRIDGE INSPECTION MANUAL

PART 2: TYPES OF INSPECTIONS

2-2.04 Inspection Plan of Action

Occasionally deterioration, scour, or other issues are found on a bridge that may require a reduced inspection frequency and/or more thorough inspection. In these cases, an Inspection Plan of Action is to be written and attached into BIAS. The Plan of Action should be detailed in describing the actions needed, the time frames they are needed, and who should be informed if additional issues are found, and how to document the findings.

2-2.05 Initial Inspections

2-2.05(01) Purpose

An Initial Inspection is the baseline inspection that shall be completed on every new bridge, after a major rehabilitation, or when the configuration or geometry of a bridge changes (e.g., when a bridge is widened).

An Initial Inspection completed on a new bridge shall be created in BIAS as a “Routine” Inspection Type, and with a new Item 90 Inspection Date, as this represents the first routine inspection in the life of the bridge. Subsequent Routine Inspections and Inspection Dates may be done earlier than the standard 24-month inspection frequency so as to allow future routine inspections be done with other bridges along the same route or within the same county.

An Initial Inspection completed on an existing bridge following the completion of a major rehabilitation project, or when either the configuration or geometry of the bridge changes shall be created in BIAS as an “Other” Inspection Type. During this “Other” Inspection, the Item 90 Inspection Date as reported in BIAS for this existing bridge shall not be changed.

An Initial Inspection is a fully documented inspection using the bridge plans (both for new bridges and rehabilitation contract plans) to determine basic data for entry into BIAS. Initial Inspections are also used when a bridge is discovered that has not been previously inventoried. In this case, bridge plans may not be available. As part of the Initial Inspection, inspectors shall evaluate the bridge and decide what other foreseeable inspections will be required throughout its life, including Fracture Critical, Special, or Underwater Inspections.

As a part of the Initial Inspection, Inspectors must review the “Bridge File” and research and look for all missing documents and have any that are found, scanned, and uploaded into ERMS and/or attached into BIAS.

BRIDGE INSPECTION MANUAL

PART 2: TYPES OF INSPECTIONS

2-2.05(02) Precision

The Initial Inspection should be a fully documented investigation. Inspectors must be able to identify any deficiencies and verify the geometric data. All observed deficiencies, cracks, construction errors, and alignment problems should be documented.

An Initial Inspection should include:

1. Verify and record all Structure Inventory and Appraisal (SI&A) data required by federal and state regulations.
2. Complete an inspection and evaluation of all required data identified in the Indiana Coding Guide in accordance with relevant chapters of this manual.
3. Complete a Basic Channel Survey, in accordance with Section 2-2.12 of this chapter.
4. Assess scour susceptibility.
5. Complete a Scour Evaluation for a bridge with substructure units over water in accordance with 4-2.01 and the BIRM (Bridge Inspection Reference Manual).
6. Note that an underwater inspection may be required if a dry period of the year cannot be found to probe the substructure units in water and the substructure units cannot be probed from a boat. The need for an underwater inspection should be verified at the first routine inspection.
7. Gather relevant information required to maintain an accurate bridge file, scan, and upload to ERMS or to BIAS.
8. Determine and evaluate the baseline structural condition.
9. Identify the location and condition of any fracture critical members or details.
10. Identify the location and condition of any details that may require a Special Inspection.
11. Verify that all clearances and geometric dimensions are correct in BIAS.
12. Verify that any protection required to shield the bridge from traffic on navigable waters is in place.
13. Identify any critical findings and notify the appropriate individuals and agencies identified in 2-4.02(01)

All inspection results shall be fully documented in the BIAS.

BRIDGE INSPECTION MANUAL

PART 2: TYPES OF INSPECTIONS

2-2.05(03) Repairs

Rehabilitation repairs are permanent repairs that are intended to improve the structural condition of a member and/or component. Access to the repair plans is needed to determine if and to what extent rehabilitation improves any specific rating number.

Bridges used to maintain traffic during construction must be inspected in the month the Routine inspection is due. The Contractor is required to provide access for inspectors to conduct NBI Inspections.

2-2.05(04) Frequency

For state-owned bridges, an Initial Inspection should preferably be completed before the new construction or rehabilitation construction contract is finalized and the bridge is open to traffic. These inspections are often performed in conjunction with the construction department's Pre-Final Inspection. Approved Initial Inspection data, including the SI&A data, must be entered into BIAS within 90 days of the completion of the construction.

For toll road, county, and local agency bridges, Initial Inspections should be completed as soon as reasonable. Approved Initial Inspection data, including the SI&A data, must be entered into BIAS within 90 days of the opening of the bridge.

A bridge not previously documented in BIAS shall receive an Initial Inspection within 90 days of the discovery of the bridge. The data must be entered into BIAS and a report approved within 90 days of the discovery of the bridge.

2-2.06 Routine Inspection

2-2.06(01) Purpose

Routine Inspections are regularly scheduled inspections consisting of observations and/or measurements needed to determine the physical and functional condition of the bridge, and to identify any changes from previously recorded conditions. The Routine Inspection also ensures that the bridge continues to satisfy present service requirements.

2-2.06(02) Precision

Routine Inspections will follow a Plan of Action, documented in the BIAS if the bridge has unique issues such as difficult access, polluted water, requires access equipment or traffic control.

Routine Inspections are generally conducted from the deck, ground, water-level, or from permanent work platforms and walkways, if present. A complete walk-around visual inspection of all components of the structure, channel, and adjacent roadway is required.

BRIDGE INSPECTION MANUAL

PART 2: TYPES OF INSPECTIONS

If the water is not safe for wading access, the inspection team should return when the flow conditions allow safe access. The inspection team may probe the underwater portion of the bridge using a boat or, conversely, using hip waders, chest waders, or wet suits. If the bridge cannot be inspected using these options, then an Underwater Inspection (92B) is necessary. The conditions that mandate an Underwater Inspection are listed in Section 2-2.08(01). The Inspection Team Leader shall submit a written request to the State Program Manager to add, modify, or remove a bridge from the list of bridges needing an Underwater Inspection.

A Routine Inspection should include the following:

1. Complete an inspection and evaluation of all required data identified in this manual in accordance with this manual.
2. Complete a Basic Channel Survey for bridges with substructure units in water every 24 months in accordance with Section 2-12.03 of this chapter.
3. Complete a Basic Channel Survey for bridges with substructure units in water in accordance with Section 2-12.03 of this chapter if required by the Scour Plan of Action, or if probing indicates a changed condition in the stream bed.
4. Verify SI&A data.
5. Gather other relevant information required to maintain an accurate bridge file, scan, and upload to ERMS or BIAS.
6. Note any existing problems or components.
7. Note the condition of fracture critical members or details.
8. Identify the location and condition of details that may require a Special Inspection.
9. Note signs of bats and cliff swallows at state-owned bridges.
10. Report significant debris or drift to the bridge owner.
11. Take alignment photos from both ends of the bridge. Closing, posting, and/or restriction signs should be visible and legible in the photos.
12. Take elevation photos, preferably of both sides of the bridge, (as a minimum on one side of the bridge). If only one elevation photo is taken, a picture of an important detail must be taken.
13. Take photos of all bridge National Bridge Inventory (NBI) Items with a condition rating of 4 or less.
14. If needed to complete the bridge file, take one clear photo under each superstructure type, clearly showing details.

BRIDGE INSPECTION MANUAL

PART 2: TYPES OF INSPECTIONS

15. If needed to complete the bridge file, take one clear photo of each substructure unit in the water.
16. If needed to complete the bridge file, take one photo looking at the upstream channel.
17. If needed to complete the bridge file, take one photo looking at the downstream channel.
18. If needed to complete the bridge file, take one photo of any fracture critical member or details.
19. If needed to complete the bridge file, take one photo of any detail that requires a Special Inspection.
20. Take photos of significant deterioration and collision damage.
21. Note if a new load rating is warranted.
22. Verify that the channel protection required to shield the bridge from traffic on navigable waters is in place.
23. Identify any Critical Findings and notify the appropriate individuals and agencies identified in Part 1-4.02.

2-2.06(03) Inspection Frequency

Bridges must receive a Routine Inspection every 24 months unless widespread deterioration dictates more frequent inspections or is on an extended frequency. If only a portion of a bridge needs more frequent inspections, a Special Inspection is required.

Bridges with a rating of 4 or less for the deck, superstructure, substructure, or culvert rating shall have a reduced interval between Routine Inspections. *A maximum inspection interval of 12 months will be used.*

2-2.06(04) Extended Inspection Frequency

Bridges within the State of Indiana that pass the screening criteria provided below are eligible for an inspection frequency of 48 months. The screening process only effects the frequency of the routine inspection. Other events may require the structure to be inspected.

As a bridge comes up for inspection, a licensed professional engineer (INDOT Bridge Inspection Team Leader with fracture critical certifications) shall review the screening document to ensure the bridge is or remains eligible for extended frequency rating. The screening document must be reviewed at each subsequent routine inspection. This screening procedure has no impact on structures that require a reduced frequency interval for routine inspections. In accordance with Section 1-2.04(03) of the INDOT Bridge Inspection Manual, bridges with a rating of 4 or less for the deck, superstructure,

BRIDGE INSPECTION MANUAL

PART 2: TYPES OF INSPECTIONS

substructure, or culvert rating shall have a reduced interval between Routine Inspections. A maximum inspection interval of 12 months shall be used.

Structures that fail the following screening criteria will not be considered for an extended frequency. Structures granted an extended frequency that become ineligible due to structural defects, condition ratings, collision or fire damage will undergo a routine inspection within seven days of the event or findings. Structures included in the program must continue to pass the screening criteria at each routine inspection.

The list of bridges eligible to have an Extended Routine Inspection Frequency, (approved by the FHWA), along with the “Extended Frequency Data Sheet” can be found in the INDOT Bridge Inspection website, in the “Bridge Inspection Documents” section. <https://www.in.gov/indot/div/public/bridgeinspect/documents.htm>

Screening criteria:

1. The deck, superstructure, and substructure must have a condition rating of 6 or greater.
2. The structure must have load path redundancy.
3. The superstructure must be constructed using steel or concrete. If the superstructure is constructed using adjacent box beams, there must be a structural concrete deck.
4. Structures over traffic must have a minimum vertical clearance of 14’-6” with minimal risk of vehicular collision and must not show signs of vehicular impact.
5. The structure must not have been recently rehabilitated or newly constructed. The structure may be considered for an extended frequency after the first routine inspection.
6. The structure must have valid load ratings with safe posting loads greater than the State’s legal loads.
7. Structure must not be highly susceptible to fire damage, or collision damage (e.g. structures with parking spaces underneath, narrow bridges, pony trusses, covered bridges).
8. The structure must not have joints that are presently leaking.
9. The structure must not be at risk of over topping and item 113 from the Structure Inventory and Appraisal Sheet must be rated N, 9, 8, 7, or 5.
10. The structure must not have fatigue prone details, out of plane bending cracks, risk of constraint-induced fracture, cover plates, or pins and hanger details.

BRIDGE INSPECTION MANUAL

PART 2: TYPES OF INSPECTIONS

11. Structures must not have an average daily truck traffic (ADTT) greater than 14,500. This value represents two standard deviations from a normal distribution which eliminates our bridges on segments of the Interstates with the highest truck volumes.
12. Complex and border bridges are not included in the alternate bridge inspection program.

Field review procedure:

1. After compliance with the screening criteria above, perform an inspection of the structure to validate the condition ratings and to detect any defect or deterioration not recorded in previous inspection reports which may disqualify the structure from being granted an extended frequency of inspection. The report must contain a clear description of all noticeable defects. The inspection may be supplemented as practical, with the necessary access equipment that will allow the bridge inspector to clearly describe the extent of any defect in the structure.
2. All aspects of the bridge are to be photo documented. For example, a single span bridge will have photos of each approach, bridge deck, profile views, each bent and one photo of the underside of the deck. The intent is to have all areas of the bridge photo documented. Any minor defects should be photographed.
3. The structure screening sheet is to be indexed and included in the BIAS report.

Approval procedure:

1. Structures wishing to have an extended inspection frequency must be on the approved list of bridges that has been approved by the FHWA and is located on INDOT's website. A complete inspection report shall be submitted (work-flowed) in BIAS to Extended Frequency. This will start the review process by INDOT to determine if the bridge can have its inspection frequency extended. In addition to having all the required inspection items included in the report (complete photo documentation of the bridge, etc.), the Extended Frequency Data Sheet must be completed, signed, and attached to the report.
2. Once the report is work-flowed to Extended Frequency in BIAS, it will be reviewed by INDOT and may be reviewed by the FHWA, if needed, for completeness and to ensure the conditions reported compare well to the data on the requirements on the Extended Frequency Data Sheet.
3. If the bridge fails the extended frequency review, the report will be work-flowed in BIAS back to the Inspector that submitted the report. A brief explanation of why it failed is included in the work-flow notes. Any deficiencies can be addressed, and the bridge re-submitted for a second review.

BRIDGE INSPECTION MANUAL

PART 2: TYPES OF INSPECTIONS

4. Bridges that pass the Extended Frequency Review, will have the Routine Inspection Frequency increased by INDOT to 48-months, along with a note about this added to the Executive Summary. In addition various data items on the MAD-Tab will be updated, and finally, the BIAS Inspection Schedule will be updated to 48-months, along with a note stating that the bridge passed the Extended Frequency review.
5. Finally, the Inspector will be notified by e-mail that his bridge passed the Extended Frequency Review. Generally Extended Frequency Bridges, shall be inspected in Phase-1 at County Inspections. The program manager will review the submitted structures and assign some structures for quality assurance review.

2-2.07 Fracture Critical Inspections

2-2.07(01) Purpose

Fracture Critical Inspections (92A) are regularly scheduled inspections to examine the fracture critical members or member components of a bridge. Fracture critical members are steel tension members or steel tension components of members, whose failure would probably cause all, or a portion of, the bridge to collapse. Fracture critical members require more thorough and detailed inspections than the members of non-fracture critical bridges.

Fracture Critical Inspections are explained in detail in Chapter 5.

2-2.07(02) Frequency

A Fracture Critical Inspection is required at regular intervals not to exceed 24 months. A fracture critical member with a rating of 4 or less shall have the frequency of inspection reduced to no greater than 12 months; this can be accomplished with a special inspection of the applicable member or connection.

2-2.08 Underwater Inspections

Underwater Inspections are a necessary part of an effective State Bridge Management Program and are mandated by the FHWA on routine intervals for bridges with substructure units in water that cannot be waded or probed.

2-2.08(01) Purpose

Because most problems that occur under water do not become visible from the surface until they are critical, bridges with substructure units in water must be inspected to ensure they are sound.

BRIDGE INSPECTION MANUAL

PART 2: TYPES OF INSPECTIONS

However, for several instances, the use of boats, kayaks, or wet suits may be an appropriate solution to avoid unnecessary underwater inspections especially if there is time during the year to do inspection while the water is shallow and calm.

Underwater Inspections are called for if scour and the condition of elements below water cannot be assessed during an overwhelming time because:

1. The substructure unit is in deep water during the entire year. Inspectors are expected to visit the site at various times to find a time when the water level and current are low enough to safely gather the necessary data as a part of the Routine Inspection; and,
2. At the lowest flow during the year, the water is too deep. Generally, if the velocity times depth is equal to or greater than 10, inspectors should not attempt wading,
3. The channel bottom is too soft for safe wading, or
4. Hazardous water quality exists.
5. At the lowest flow during the year, the water is too deep for probing from a boat.

2-2.08(02) P r e c i s i o n

Every Underwater Inspection must follow a Plan of Action. The Plan of Action must include:

1. A timetable for conducting the inspection.
2. The personnel requirements for each portion of the inspection.
3. A list detailing what is required to be inspected.
4. The required access equipment.
5. The required traffic controls.

An Initial Underwater Inspection should include the items listed above. Subsequent inspections may be modified based on field conditions. For example, the number of cross sections may be reduced if the inspector is confident that the stream is stable.

1. A detailed listing of the divers participating in the inspection complete with duties performed and a complete listing of credentials. This will include diving credentials and Bridge Inspection Team Leader and Team Member numbers issued by the Bridge Program Manager (SPM). This information must be placed on the first section of the inspection report.
2. A detailed Channel Survey as described in 2-2.12 of this chapter, including channel soundings and waterline elevations.

BRIDGE INSPECTION MANUAL

PART 2: TYPES OF INSPECTIONS

3. Photographs including:
 - a. Overall views of the Bridge.
 - b. General views of each substructure unit (both sides and noses).
 - c. Significant defects.
 - d. Typical material condition at the water line.
4. Sketches showing:
 - a. The substructure layout, including overall bridge length and each substructure unit length and width.
 - b. The shoreline limits upstream and downstream of the bridge.
 - c. A north arrow.
 - d. The width of the channel at the bridge.
5. A record of the water velocity at the deepest point in the channel.
6. A record of the channel bottom material adjacent to all submerged substructure units.
7. A record of the shoreline conditions and material.
8. A check of the foundation type to ensure it has been correctly coded in Item 113.
9. Complete pre-dive and post-dive checklists.
10. A record of defects, noting section loss and dimensions.
11. Notifying of the owner of any significant deficiencies.
12. Reviewing available plans against the current condition for changes.
13. Making preliminary recommendations if needed.

All inspection results should be fully documented in the BIAS. Critical findings shall be reported to the appropriate individuals and agencies identified in 2-4.02.

Due to limited underwater visibility, the inherent access restrictions of the underwater environment, and the presence of marine growth, the required underwater inspection precision depends on the level of effort. Three underwater diving inspection levels of effort are defined by the FHWA. A standard Underwater Inspection in Indiana requires a Level I effort on 100 percent of all underwater elements. A Level II or III effort shall be conducted only if defects or advance deterioration are found or suspected, and then only at the direction of the SPM.

A summary of the Inspection Levels and typical detectable defects is provided in [Figure 2-1.2](#). A narrative description of each level follows.

BRIDGE INSPECTION MANUAL

PART 2: TYPES OF INSPECTIONS

Level I Effort

A Level I Inspection is a visual or tactile examination using large sweeping motions of the hands where visibility is limited. A Level I effort must be detailed enough to detect obvious major damage or deterioration due to overstress or other severe deterioration. It should confirm the full-length continuity of all members and detect undermining or exposure of normally buried elements. A Level I effort also includes limited probing of the substructure and adjacent channel bottom.

Level II Effort

The Level II effort is intended to detect and identify damaged and deteriorated areas that may be hidden by surface biofouling. A Level II inspection requires marine growth to be removed from portions of the bridge. The thoroughness of cleaning should be governed by what is necessary to discern about the condition of the underlying material. A detailed inspection of a representative sample of the components is required. For piles, a 12-inch high band should be cleaned at designated elevations, generally near the waterline, at the mudline, and midway between the waterline and the mudline. On an H-pile, marine growth should be removed from both flanges and the web. On a rectangular pile, the marine growth removal should include at least three sides; on an octagonal pile, at least six sides; and on a round pile, at least three-fourths of the perimeter. On piles with a diameter of three feet or greater, one-foot squares should be cleaned at four locations spaced approximately equally around the perimeter, at each designated elevation. On large, solid-faced elements such as pier shafts, one-foot squares should be cleaned at four random locations, at each designated elevation. In addition, The Level II effort should focus on typical areas of weakness such as attachment points and welds.

Level III Effort

The Level III effort is generally limited to key structural areas which are suspect or areas which may be representative of the underwater structure. A Level III Inspection typically involves NDT or partially destructive testing (PDT) to detect hidden or interior damage, or to evaluate material homogeneity. Testing techniques typically include the use of ultrasonic, coring, or boring, and in-situ hardness testing. Refer to Part 6 of this manual for additional information on NDT and PDT.

The SPM will be notified of all Critical Findings identified in this inspection, as detailed in Part 2-4.02 of this manual. Critical Findings will be submitted in BIAS for all bridges.

All inspection results should be fully documented in BIAS.

BRIDGE INSPECTION MANUAL

PART 2: TYPES OF INSPECTIONS

2-2.08(03) F r e q u e n c y

The standard interval for Underwater Inspections is 60 months. This interval is for bridges that are in good condition underwater, located in passive, nonthreatening environments, and have not had any significant changes in the submerged substructure units or channel bottom since the previous Underwater Inspection. If warranted due to deficiencies or deterioration, the inspection interval may be reduced to less than 60 months.

A frequency of 48 months is to be used when there have been changes in the submerged substructure units or channel bottom since the previous inspection that are serious enough to warrant tighter scrutiny, but not serious enough to require corrective action.

A 36-month frequency is to be used when there have been substantial changes in the submerged substructure units or channel bottom since the previous inspection, or problems have developed that require corrective action.

A 24-month frequency is to be used when serious submerged substructure unit deterioration or scour/channel problems exist. The deficiencies should be immediately addressed, or the bridge should be rehabilitated or replaced in the very near future.

A 12-month frequency is to be used when very critical submerged substructure unit deterioration or scour/channel problems exist. The deficiencies should be immediately addressed, or the bridge should be rehabilitated or replaced in the very near future.

The investigation into the need for an Underwater Inspection may begin at the initial inspection. Follow the guidelines of 2-2.08(01) to verify the need for an underwater inspection. Addition of an underwater inspection require the concurrence of the SPM. When the current frequency is out of compliance to the frequencies outlined above, the Inspection Team Leader shall write the SPM requesting a change in frequency citing the reasons as listed above.

Increasing frequency: The inspection frequency may be increased from a reduced frequency if the situation that required the reduced frequency has been properly addressed or if it has been observed over several inspections the situation has stabilized. The increase in frequency will be made in writing and must have the approval from the SPM.

Any bridge that has been receiving an Underwater Inspection can be removed from this requirement by providing the SPM documentation showing that the in-water substructure units can be properly inspected in full using normal means during a Routine Inspection.

2-2.09 Special Inspections

BRIDGE INSPECTION MANUAL

PART 2: TYPES OF INSPECTIONS

2-2.09(01) Purpose

Special Inspections (92C) are scheduled to examine a portion of a bridge in more detail or at a greater or lesser frequency than is standard for Routine Inspections. Special Inspections may provide follow-up after a Routine, Damage, or Initial Inspection. The Special Inspection mandates the component being inspected is at arm's length, and NDE methods utilized when necessary to complement visual evaluations.

Details and bridges that may require a Special Inspection include the following:

1. Fatigue category E and E' details (Most welded steel cover plates can be removed from this category. Historical evidence has shown by both Purdue research and detailed inspections since +- 1988, that cracks rarely develop, even from poor welds, and if they do, they grow very slowly. If a detail has a +- 30-year history of no cracks, an Inspector can request that the State Program Manager remove this from requiring a Special Inspection of these details).
2. Hangers of all types
3. Hinge or pin connections
4. Known defects, significant section loss/deterioration, or damage severe enough to warrant extra scrutiny.
5. Unique or problematic details as determined by the SPM.

Complex Bridges that require a Special Inspection include the following:

1. Bridges designated by the SPM
2. Cable-stayed bridges
3. Movable bridges*
4. Suspension bridges

** Movable bridges in Indiana require a Fracture Critical Inspection on their superstructure members. Due to this, it has been decided that the Complex Inspection of the hydraulic, electric, and mechanical systems will be included as a part of the Fracture Critical Inspection for NBI recording purposes, and Special Inspections will not be coded, unless a condition rating is a 4 or less. Highly qualified personnel that meet the Complex Inspection Plan of Action are required for these parts of the bridge inspection.*

2-2.09(02) Precision

Special Inspections may include a Plan of Action, if required. The Plan of Action may include:

1. A timetable for conducting each inspection.

BRIDGE INSPECTION MANUAL

PART 2: TYPES OF INSPECTIONS

2. The personnel requirements for each portion of each inspection.
3. A list detailing what is required to be inspected under each inspection.
4. The required access equipment needed for each inspection.
5. The required traffic control for each inspection.

For bridges that require a Special Inspection because of unique or problematic details, the inspector must make sufficient measurements and observations to quantify the deficiencies to allow for future monitoring. Inspectors should document:

1. The physical and functional conditions of the known or suspected deficiency.
2. Any developing problems such as deterioration, foundation settlement, scour or erosion of the slopes, scour at the supports, ice damage, or other problems that, if left unchecked, would degrade the load-carrying capacity of the bridge.
3. Signage is in place and visible for load-posted or restricted bridges.
4. The ability of the bridge to satisfy its present service requirements.

Inspection results must be recorded in BIAS. The date of the inspection and a list of the deficiencies investigated must be included. If any deficiency has become more severe, it may be necessary to notify the owner and re-evaluate the bridge load rating. Critical findings shall be reported to the appropriate individuals and agencies identified in 2-4.02.

Some Special Inspection tasks need not be performed with an Inspection Team Leader on site. Inspection Team Members can be sent out to perform specific inspection or measurement tasks under the direction of an Inspection Team Leader. Such tasks might include measuring a crack, photographing a weld, or measuring section loss on specific members. These tasks must be clearly documented in the Special Inspection Plan of Action. The Inspection Team Leader is still required to review and sign off on all inspection data entered in BIAS.

For state-owned complex bridges that require a Special Inspection, a lead Inspection Team Leader is assigned by the State Program Manager. The Plan of Action will be developed and modified by the lead Inspection Team Leader in consultation with the State Program Manager.

The lead Inspection Team Leader for state-owned complex bridges may or may not be the Inspection Team Leader for any individual inspection performed as a part of the Special Inspection. The Inspection Team Leader for each individual inspection will approve the inspection results entered in BIAS for that inspection. The lead Inspection Team Leader must review all individual inspections performed as a part of the Special Inspection, as well as generate/approve a summary of the Special Inspection. This summary must be entered in BIAS.

BRIDGE INSPECTION MANUAL

PART 2: TYPES OF INSPECTIONS

Inspection teams for state-owned complex bridges may consist of state personnel, consultants, or a combination. The lead Inspection Team Leader will ensure that each team is working within the scope of its professional ability.

For toll road, county, and local agency complex bridges that require a Special Inspection, a lead Inspection Team Leader may be assigned by the Inspection Consultant but must be approved by the SPM.

The Plan of Action will be developed and modified by the lead Inspection Team Leader in consultation with the State Program Manager.

The lead Inspection Team Leader must review all individual inspections performed as a part of the Special Inspection, as well as generate/approve a summary of the Special Inspection. This summary must be entered in BIAS.

Depending on the extent of the damage or deterioration, a Special Inspection may include a recommendation for a load rating to assess the capacity of damaged or deteriorated members. Nondestructive tests and/or other material tests may be needed to assist in determining the safe load-carrying capacity.

Critical findings shall be reported to the appropriate individuals and agencies identified in 2-4.02.

All inspection results should be fully documented in BIAS.

2-2.09(03) F r e q u e n c y

Special Inspections for unique and problematic details are completed in addition to Routine Inspections. The maximum inspection interval for a Special Inspection is 60 months. A problematic detail that is performing well on a structure can have an inspection interval of 60 months. A structure with a problematic detail that has a rating of 4 or less shall be inspected on a 12-month interval.

A written request shall be sent to the SPM requesting the Special Inspection be removed if the detail has been retrofitted or rehabilitated.

The inspection frequency of each component inspection of a Special Inspection for a complex bridge may be identified in the Plan of Action. It may be most efficient to conduct all the inspections at one time, using the same inspectors. However, it may not be practical to schedule inspections requiring different types of traffic control, access equipment, or NDT at the same time.

gf

BRIDGE INSPECTION MANUAL

PART 2: TYPES OF INSPECTIONS

2-2.10 In-Depth Inspection

2-2.10(01) Purpose

An In-Depth Inspection is a close-up inspection that allows for the detection of deficiencies that are not readily identifiable during a routine inspection. In-Depth Inspection Reports shall be created in BIAS as an “Other” Inspection Type. During this “Other” Inspection, the Item 90 Inspection Date as reported in BIAS for this existing bridge shall not be changed. The term close-up is used which indicates this is not a hands-on inspection but is still well within visual range so that defects can be seen.

An In-Depth Inspection is a scheduled inspection which is scheduled at a maximum 96- m o n t h interval for structures that meet the following criteria:

1. The structure is of the type that does not require a scheduled hands-on inspection.
2. The structure contains elements not easily inspected during a routine inspection.
3. The structure has been selected by the Program Manager.

Inspectors shall create an “Other” Inspection type in BIAS when creating an “In-Depth” Inspection Report. They shall attach the details of the inspection to the BIAS Report, in a report format like that done for a Fracture Critical Inspection Report.

2-2.10(02) Precision

The scope of an In-Depth Inspection should be to inspect the entire structure close up. This is a relatively infrequent inspection scheduled for structures that typically do not require a scheduled inspection beyond the routine inspection. This inspection will give the inspector the opportunity to make sure that all the components of the structure are performing as intended.

2-2.10(03) Frequency

The maximum frequency of an in-depth inspection is 96 months.

2-2.11 Damage Inspections

2-2.11(01) Purpose

BRIDGE INSPECTION MANUAL

PART 2: TYPES OF INSPECTIONS

A Damage Inspection is an unscheduled inspection to assess structural damage resulting from environmental factors or human actions. Flood damage, fire damage, barge impact, and vehicle impact are examples of events that may call for a Damage Inspection.

2-2.11(02) Precision

The scope of a Damage Inspection should be sufficient to determine whether there is a need for emergency load restriction, or closure of part or all the bridge to traffic. Inspectors of state-owned bridges should also assess the level of effort necessary to repair the damage. The amount of effort expended on this type of inspection may vary significantly and depends on the extent of the damage. If major damage has occurred, the inspector shall document the damage, including measuring section loss or misalignment, and any loss of foundation support.

Inspection data and pictures shall be entered into BIAS as soon as possible, and no more than seven days after the inspection. This inspection may be supplemented by a timely Special Inspection to document the extent of damage and the urgency and scope of repairs more fully. A more refined analysis, to establish or adjust interim load restrictions, may also be required as follow-up for a Damage Inspection. A structural engineer may need to be consulted for the inspection or analysis. If the inspection identifies a Critical finding, the inspector must follow the notification procedures outlined in 2-4.02.

A damage inspection is required for all bridges in which the event has left permanent physical evidence. The damage inspection data and pictures shall be entered into BIAS as soon as possible and no more than seven days after the inspection.

The Inspector of state-owned bridges should gather data on the vehicles and drivers involved and any police report after a crash. This information will be used to bill the appropriate insurance company for damages.

Collisions to State owned bridges are also recorded in a table in SharePoint and are submitted to INDOT's Mobility Section for their annual report to the FWHA on bridges impacted by traffic.

2-2.11(03) Frequency

A Damage Inspection is an unscheduled inspection that is performed to determine if significant damage has been done to the bridge. Based on the findings of the damage inspection, the inspector will determine if the damage warrants placing the structure on a special detail inspection. Pictures of any damage will be uploaded into BIAS with a complete description of the event. Generally, a law enforcement officer on the site of an accident involving a bridge will notify the owner who will request a Damage Inspection be performed to determine if the bridge should be closed. Damage Inspections may be needed after flooding or earthquakes.

BRIDGE INSPECTION MANUAL

PART 2: TYPES OF INSPECTIONS

2-2.12 Channel Surveys

2-2.12(01) Purpose

Scour is the movement of channel bed material by the action of moving water. This movement may result in degradation (i.e., erosion of material), as well as aggradation (i.e., accumulation of material). These changes in the channel bed may lead to bridge instability and are generally identified by profiling the channel bottom. Comparison of previous profiles is typically needed to detect and assess scour. Plotting the underwater measurements of the stream bottom and probing bridge foundations are two of the most important aspects of inspecting a bridge for scour.

Channel cross section data is used to evaluate trends in channel bottom movement and to compare channel bottom elevations to footing elevations.

Indiana has two levels of Channel Survey: basic and in-depth.

2-2.12(02) Precision

For all Basic Channel Surveys, the elevation of the waterline must be referenced to a bridge element (such as top of railing or coping, etc.). For In-depth Channel Surveys, the elevation of the waterline should be referenced to a known elevation on the bridge.

For a Basic Channel Survey, bottom elevations are required:

1. At the upstream fascia, locate enough points between substructure units to identify any problems or deficiencies. As a minimum, three points to five points are required for a typical one span structure. Typically, the elevations are taken at substructure units, at mid-channel, and at the channel edges, depending on the contours of the channel and the overall width of the channel.

The notes of how-to layout the survey must be stored in BIAS. Once the survey method and points are determined, the process can be repeated on future Routine Inspections. The creation of a bridge profile sketch/plot the channel survey profile must be attached to the BIAS report for which the profile was taken.

It is recommended that the BIAS Scour Channel Profile Tab be used for plotting the data gathered. However, if this tool is not used, the plotted channel data must still be uploaded into BIAS and attached to the appropriate BIAS Inspection Report.

2. Bridges that are metal pipes or concrete boxes (with bottoms), generally will only require one measurement, taken at midspan, (usually at the inlet), unless a scour hole exist at the inlet or outlet. If scour is noted, additional measurements may be needed to outline its extent.

BRIDGE INSPECTION MANUAL

PART 2: TYPES OF INSPECTIONS

3. Scour issues found during any basic channel survey should be reported to either INDOT Maintenance or the appropriate County Engineer, so that they can determine the proper fix for the situation.

Note: Measurements at the downstream fascia can/should be taken if scour issues are located at the downstream portions of the bridge, possibly caused by the angle of attack of the normal channel flow.

For an In-depth Channel Survey, bottom elevations are required:

1. Around each substructure unit in the water, and at enough points around the unit to identify any problems or deficiencies, (bridges with hammer head pier caps shall be measured at both pier noses as well as well as at both fascia)
2. At and between substructure units along the centerline of the bridge at enough points between substructure units to identify any problems or deficiencies. A minimum of three points between each substructure and one point at each substructure is required.
3. At the upstream fascia, at enough points between substructure units to identify any problems or deficiencies. A minimum of one point at each substructure and three points between each substructure is required.
4. At the downstream fascia at enough points between substructure units to identify any problems or deficiencies. A minimum of one point at each substructure and three points between each substructure is required.
5. At additional locations, if required, to adequately determine the thalweg of the waterway. The thalweg is the line that connects the lowest point in the waterway, and which has the fastest flow, (it is also the middle of any navigable channel). Substructure units in the waterway near the thalweg could be susceptible to scour.
6. At as many locations that are needed when an unusual change in the channel has been identified.

The following measurement locations are optional if they are required to measure/track channel changes and/or embankment scour*

7. 100 feet upstream at enough points between substructure units to identify any problems or deficiencies. A minimum of one point at each substructure and three points between each substructure is required.
8. 200 feet upstream at enough points between substructure units to identify any problems or deficiencies. A minimum of one point at each substructure and three points between each substructure is required.

BRIDGE INSPECTION MANUAL

PART 2: TYPES OF INSPECTIONS

9. 100 feet downstream at enough points between substructure units to identify any problems or deficiencies. A minimum of one point at each substructure and three points between each substructure is required.
10. 200 feet downstream at enough points between substructure units to identify any problems or deficiencies. A minimum of one point at each substructure and three points between each substructure is required.

* When the bridge length is less than 100-feet long, the optional upstream and downstream profiles should be taken at locations equal to the bridge length and twice the bridge length.

11. Every in-depth Channel Survey Inspection will follow a Plan of Action. The Plan of Action (POA), must include:
 - a) A timetable for conducting the survey.
 - b) The qualifications of the personnel required to conduct the survey.
 - c) A list detailing what is required to be measured and where, in the survey.
 - d) The required access equipment.
 - e) The required traffic control on the roadway above or in the waterway (if needed).

Water depth measurements should be recorded to the nearest tenth of a foot. Scour evaluations are typically based on changes in elevations greater than 0.5 foot since most channel bottoms are irregular surfaces with random cobbles, debris, and sand ripples.

The water surface elevation should be referenced to a known elevation or reference point on or near the bridge.

The individuals taking the profiles need not be a Bridge Inspection Team Leader; however, the profiles must be reviewed and compared to known substructure elevations and past profiles by a qualified Bridge Inspection Team Leader.

2-2.12(03) F r e q u e n c y

Channel Surveys are performed concurrently with many of the required inspections of a bridge over water. After the initial basic Channel Survey is completed, additional Channel Surveys shall be performed every two years during a Routine Inspection, unless an Underwater Inspection has been conducted within the previous 12-month period, and an in-depth channel survey was conducted as a part of that inspection.

If a bridge is on an Extended Inspection Frequency, a basic channel survey is only required every four years.

BRIDGE INSPECTION MANUAL

PART 2: TYPES OF INSPECTIONS

A basic Channel Survey may be required after large flood events or when channel changes have occurred.

A basic Channel Survey is required for all Initial Inspections, and as required in the Scour Plan of Action for Scour Critical Bridges.

An In-Depth channel survey is performed during all underwater inspection unless directed otherwise by the SPM, (such as when an in-depth underwater inspection is performed to only measure section loss on steel piles – at a reduced inspection frequency).

2-2.13 Large Culvert Inspection

Large culverts are culverts (structures) with spans equal to or greater than four feet and less than or equal to 20 feet, and with clear openings (measured perpendicular to the clear opening of the culvert) not less than 48 inches.

Large culvert structures shall include multiple pipes placed side by side where the extreme measured ends of openings is equal to or greater than 48 inches, so long as the clear distance between openings is less than half of the smallest contiguous opening. The skew of the culvert structure is not considered to determine the culvert length.

2-2.13(01) Purpose

Large Culvert Inspections are basically Routine Inspections for these types of structures. They are regularly scheduled inspections consisting of observations and measurements needed to determine the physical and functional condition of the structure to identify any changes from previously recorded conditions. The Large Culvert Inspection also ensures that the structure continues to satisfy present service requirements.

2-2.13(02) Precision

These inspections should be conducted with the same precision and attention to detail outlined for Routine Inspections in Section 2-2.06.

The State Program Manager should be immediately notified of all Critical Findings identified in this inspection as detailed in 2-4.02 of this manual. A Critical Finding for a large culvert requires immediate reporting and appropriate action to resolve the finding. However, the workflow in BIAS is not used for Large Culverts.

All inspection results should be fully documented in BIAS.

BRIDGE INSPECTION MANUAL

PART 2: TYPES OF INSPECTIONS

Condition Ratings for Large Culverts shall be based on the rating scale and descriptions as shown on page #38 of the “1995 White” Recording and Coding Guide for the Structure Inventory and Appraisal of the Nations Bridges, and not NBI Item #62, as shown on pages #41 and #42 of the same Manual.

2-2.13(03) F r e q u e n c y

All state-owned large culverts shall be inventoried. State-owned large culverts with a condition rating of 7 or above may be scheduled for a Large Culvert Inspection not to exceed 72 months.

State-owned large culverts with a condition rating of 5 or 6 may be scheduled for a Large Culvert Inspection not to exceed 48 months. State-owned large culverts with a condition rating of 4 or less should be scheduled for a Large Culvert Inspection not to exceed 12 months.

Corrugated metal pipe culverts (both lined and unlined) with constant flow are to be limited to a maximum 48-month frequency of inspection.

All Indiana Toll Road large culverts should be inventoried. Indiana Toll Road large culverts should be inspected as described above for INDOT large culverts.

County and local agency large culverts should be inspected at the discretion of the owner in consultation with the Inspection Consultant. It is recommended that all counties inventory all large culverts.

Large Culvert Inspections may be scheduled in conjunction with any other inspection type.

2-2.14 Bridges Closed To Traffic

If a bridge is closed to all traffic, for construction when an inspection is due, the inspection team shall:

1. Document the bridge is properly closed with photos. If the bridge is being used to maintain traffic, the bridge must be inspected.
2. Code NBI #41 as “G” (new structure not yet open to traffic) or “K” (closed to traffic), as appropriate, in BIAS.
3. Code the appropriate NBI Date Item(s) with the date the inspectors were at the bridge.
4. Note that the inspection date was changed in the Central Data base
5. Verify the estimated date of completion of the construction.
6. Schedule in BIAS, a new Initial Inspection, and all other required inspections for the estimated completion date. All rescheduled inspections must be completed within 90 days of being

BRIDGE INSPECTION MANUAL

PART 2: TYPES OF INSPECTIONS

opened to traffic. The Routine Inspections shall remain in the month that it had been prior to construction, once the Initial Post-construction Inspection is complete.

7. Leave other NBI data items unchanged, until the Initial Inspection is conducted.

If a bridge is only partially closed to traffic during construction, then an NBIS Inspection is required. On INDOT Bridges, the contractor is required to provide a time and access for Inspectors to conduct all needed inspections.

If a bridge has been closed permanently when inspection is due, the inspection team shall:

1. Document the bridge is properly closed with photos. No other inspection work is required. If the bridge is not properly closed, a critical finding must be immediately submitted.
2. Code NBI #41 as “K” (closed to traffic) in BIAS.
3. Code the appropriate NBI Date Item(s) with the date the inspectors were at the bridge.
4. Note that the inspection dates were changed in the BIAS.
5. Leave other NBI data items unchanged.
6. Recommend the removal of the bridge be scheduled as soon as possible.

Permanently closed bridges are generally not eligible to use federal bridge inspection funds to conduct inspection activities.

2-3.0 REPORTING SYSTEMS

2-3.01 Bridge File

The bridge file is the collective term for all documents necessary to provide a comprehensive history of each Bridge Asset. There are three official repositories for documents that comprise the bridge file: the Bridge Inspection Application System (BIAS), the INDOT Electronic Records Management System (ERMS) and BRADIN. The FHWA *Manual for Bridge Evaluation* contains various documents that should be included in the bridge file. At a minimum, the bridge file is to contain the following documents prior to being identified as complete, if available. Each item is annotated with the required repository.

1. Bridge Inspection Reports – BIAS. A minimum of 10 years of inspection history is required for all assets more than 10 years old.
2. Scour Screening/Scour Assessment - BIAS
3. Original Plans (Either Approved Design signed by PE or As-Built Record) - ERMS

BRIDGE INSPECTION MANUAL

PART 2: TYPES OF INSPECTIONS

4. All Bridge Rehabilitation Plans (Either Approved Design signed by PE or As-Built Record) - ERMS
5. Hydraulic Calculations/Hydraulic Models - ERMS
6. Asbestos Reports – ERMS
7. Significant Correspondence – ERMS. Significant correspondence includes agreements regarding inspection responsibility, ownership, or other issues that have an impact on timely inspections.
8. Scour Plan of Action – ERMS. For scour critical bridges, provide a copy of the plan of action.
9. Memoranda of Agreement (including Maintenance Agreements), where applicable – ERMS
10. Relinquishment Agreements, where applicable – ERMS
11. Load Rating Reports and Load Rating Calculations/Models are NO LONGER included in BIAS. These documents are uploaded through ERMS into BRADIN. Old Load Rating Documents prior to June 2018 shall remain in BIAS, until uploaded into ERMS in the future.

2-3.02 BIAS

All bridge reports, including bridge inspection, scour screening, scour assessment, and asbestos are to be housed in BIAS. Load Rating reports, calculations, and calculation models are to be housed in BRADIN, using ERMS. Bridge inspection reports - routine, fracture critical, under water, special, damage, asbestos, and other - must be created in a BIAS report. All report sections must be added in the Report Sections tab - Add Sections/PDF Attachments and the file uploaded into the report. The added sections must also be included in the report table of contents. Uploading a PDF attachment without adding it to the report reduces the efficiency of retrieving/reviewing the information and is not acceptable.

The required bridge inspection report sections are listed below. Instructions on how to create a report in BIAS and upload a file into a report as well as the required file naming convention are attachments in BIAS, in the HELP Tab, (at the top of the screen), and then under Documentation.

The required report sections in a bridge inspection report include the following:

1. Report Cover.
2. Location Map.

BRIDGE INSPECTION MANUAL

PART 2: TYPES OF INSPECTIONS

3. Executive Summary. The executive summary is to include a brief the contract rehabilitation history and general statement of condition of the bridge and a statement of areas of concern.
4. National Bridge Inventory and Miscellaneous Asset Data.
5. Field Inspection Information. Field inspection information is to include sketches and photographs showing typical and deteriorated conditions. A brief narrative is required to justify a change in condition rating. An NBI item rated below 5 or condition state 3 requires a picture or sketch in addition to narrative descriptions of the deteriorated condition. A plan of action is to be included, if required. All pictures inspection report is to be labeled.
6. Critical Findings. Critical finding documentation is to be in accordance with Part 1 of the Bridge Inspection Manual.
7. Waterway Information. Waterway information is to be in accordance with Part 2 section 2-2.12 Channel Surveys of the Bridge Inspection Manual.
8. Other Inspection Procedures. Other inspection procedures include other required reports such as fracture critical and under water. These reports are to be in accordance with Part 1 of the Bridge Inspection Manual.
9. Posting Documentation. Posting documentation is to be in accordance with Part 3 of the Bridge Inspection Manual.
10. Scour Assessment. The assessment conducted to determine the scour vulnerability of the bridge is to be documented.
11. Pictures and Sketches. All pictures and sketches in the inspection report are to be labeled.
12. Load Rating. See Part 3 of the Bridge Inspection Manual for items to be included in BRADIN.
13. Creating a Report in BIAS and Uploading a File (attachment) into a BIAS Report [2-1.3: CREATING A REPORT IN BIAS](#)

2-3.01 ERMS

ERMS is the only repository other than BIAS that may house bridge file documents. When properly indexed, documents in ERMS for a bridge asset can be viewed in BIAS from the Asset tab.

Instructions on how to upload a file into the ERMS Bridge File Documents folder using the Multiple File Upload Tool and the required file naming convention are listed below. [2-1.4: REQUESTING ACCESS](#)

Bridge File Documents Naming Convention

| Document Type Description | Document Type Abbrev. |
|----------------------------------|------------------------------|
| Asbestos Report | AsbRpt |
| Contract Information Book | CIB |
| Correspondence | Corresp |
| Critical Finding | CritFind |

BRIDGE INSPECTION MANUAL

PART 2: TYPES OF INSPECTIONS

| | |
|---|--|
| Hydraulic Analysis | Hydro |
| Hydraulic Memo | HydroMemo |
| Load Posting | LoadPst |
| Load Rating | LoadRtg |
| Load Rating Memo | LoadRtgMemo |
| Load Rating Model | LoadRtgMdl |
| Load Rating Summary | LoadRtgSum |
| Memorandum of Agreement | MOA |
| Scoping Report | ScopeRpt |
| Scour Additional | ScourAddt |
| Scour Analysis | ScourAnalysis |
| Scour Memo | ScourMemo |
| Scour Plan Of Action | ScourPOA |
| Scour Plans | ScourPlans |
| Scour Report | ScourRpt |
| Transfer/Relinquish | TR |
| Document Type Description for Plans | Document Type Abbrev. |
| Original | Plans [supplemental description] |
| Rehab | Plans O |
| | Plans R (if known use the Rehab designation letter A, B, C, etc.) |
| Replacement | Plans RP |
| Removal | Plans RM |
| As built | Plans AB |
| Shop Plans | Plans Shop |
| Document Type Description for Inspection Reports | Document Type Abbrev. |
| | BrInsp [supplemental description] |
| Underwater | BrInsp U |
| Routine | BrInsp R |
| Fracture Critical | BrInsp F |
| Special | BrInsp S |

Note: The ERMS County Bridge Inspection Reports folder is for County Summary documents only. All other documents and reports should be in BIAS or the ERMS Bridge File Documents folder.

Countywide Bridge Inspection Final Reports must now be submitted using the ERMS Multiple File Upload Tool (MFUT).

(MFUT). Users should choose County Bridge Inspection Reports from the Document Type dropdown list in the MFUT prior to selecting files for upload.

The File Naming Convention will remain the same and should be as follows:

BRIDGE INSPECTION MANUAL

PART 2: TYPES OF INSPECTIONS

Transmittal [Year] [PH I / PH IA / PH II / PH IIA] [CO NO.] [TransLtr] [Des No] for Bridge Services.pdf

Example: 2019 PH I 49 TransLtr 1382084 for Bridge Services.pdf

Final Report [Year] [PH I / PH IA / PH II / PH IIA] [CO NO.] [InspRpt] [Des No] for Bridge Services.pdf

Example: 2019 PH I 49 InspRpt 1382084 for Bridge Services.pdf

As a reminder, there is a 50 MB limit for each file uploaded into ERMS. In the event a file must be split into multiple files, the user should append “Part #” to the end of the filename.

Example: 2019 PH I 49 InspRpt 1382084 for Bridge Services Part 1.pdf

The LPA Bridge Inspection Project Manager will be notified by ITAP when the file upload is complete.

If you have questions, please contact INDOT’s LPA Bridge Inspection Project Manager.

2-3.02 Structure Identification

2-3.02(01) N B I Item 8 Structure Number

NBI Item 8, Structure Number, is called Item 8, Structure Number (NBI number) in BIAS. This number is assigned by the Inspection Consultant for county bridges and by the State Program Manager for state bridges. This number is seven digits long for county bridges. The first two digits are the county number. State bridges use up to six-digit numbers. The NBI number is unique and remains unchanged throughout the life of a bridge. When a bridge is replaced, the new bridge gets a new NBI number.

Bridges that are transferred ownership between the state and other agencies, including local governments shall retain the NBI Number originally assigned to it.

2-3.02(02) I N D O T Bridge Number

The state uses an alpha-numeric numbering system to identify the Indiana Department of Transportation (INDOT) Bridge Number. Up to 19 digits are reserved for this number, excluding parentheses and dashes, and for new bridges it is generally in the form “A (123)456-789-12345 BCDE.” The following describes each part of the INDOT Bridge Number:

1. a. Up to one letter to indicate property designation:

BRIDGE INSPECTION MANUAL

PART 2: TYPES OF INSPECTIONS

- b. I for Interstate bridges
 - c. P for state properties including parks, prisons, and hospitals
 - d. Blank for bridges on a designated United States (U.S.) or state route (S.R.)
2. (1234)5678: Up to eight digits to designate the road number. Parentheses are required only if the road number has changed. For these situations, indicate the current road number within the parentheses and indicate the old road number to the right of the parenthesis, (this where the original plans are located). If the bridge route has changed since being built, as in the example, (1234) is the current route and 5678 is the route the bridge was originally built on.
- Include leading zeros if the road number is less than three digits (e.g., use 008 and not 8 for Route 8).
- The use of I's for Interstate and P's for Property Bridges is required unless space limits the number of digits that can be used.
3. 123: Up to three digits to designate Interstate log mile or county number, depending on the bridge. If the bridge is located on an interstate, this number is up to three digits long, with no leading zeros, and designates the mile post rounded to the nearest whole mile. If the bridge is located on any other type of road, this is always a two-digit number, with a leading zero if necessary, that designates the county number. There are 92 counties in Indiana. County number 93 is used for border bridges that are inventoried by Kentucky or Illinois or are Indiana's inventoried bridges located south of the state line on US 41.
4. 12345: Five digits to designate the Structure Number. It is a consecutively assigned number assigned by the State and is not related to Item 8, {the Structure Number (NBI Number)}. Leading zeros are required to ensure five digits. Typically, the 02000 series bridges are reserved for bridges over or under a railroad.
5. BCDE: Up to four letters to designate the structure designation.
- a. The first letter indicates:
 - i. J Parallel, but different bridge, (length, width, flared, etc.)
 - ii. A First contract rehabilitation
 - iii. B Second contract rehabilitation
 - iv. C Third contract rehabilitation, etc.
 - b. The remaining three letters complete the structure designation as follows:

BRIDGE INSPECTION MANUAL

PART 2: TYPES OF INSPECTIONS

- | | | |
|-------|-----|------------------------|
| i. | EBL | Eastbound Lane |
| ii. | WBL | Westbound Lane |
| iii. | NBL | Northbound Lane |
| iv. | SBL | Southbound Lane |
| v. | ADJ | Adjacent to Mainline |
| vi. | CD | Collector Distributor |
| vii. | DR | Directional Ramp |
| viii. | R | Ramp |
| ix. | NC | Northbound Collector |
| x. | NWE | Northwest-to-East Ramp |
| xi. | SC | Southbound Collector |
| xii. | DRN | Directional Ramp North |
| xiii. | RWN | Ramp West to North |

(The above may not be the entire list of acceptable Structure Designations, but they are the most used.)

When a bridge is both a parallel bridge and has been rehabilitated, use the first two letters of BCDE to show this and drop the third letter describing the structure designation. For example, JCNB would indicate that the bridge is one of two parallel structures, has been rehabilitated three times, and serves northbound lanes.

Many older bridges within Indiana do not adhere to these guidelines. Bridges along state borders may have special agreements that determine the ownership of the bridges and the bridge number.

Prior to SPMS generating INDOT Structure Numbers, in the early 2000's, twin bridges were given the same five-digit Structure Number, but were given a different Structure Designation, such as NBL & SBL.

2-3.02(03) Toll Road Bridge Numbers

The Indiana Toll Road uses a numbering system similar to the state bridge numbering system that is generally in the form "A(123)456-78-91234 BCD." The following describes the state bridge numbering system:

1. A: One letter coded I for all toll road bridges.
2. (123): Current road number. The leading zero is sometimes omitted.

BRIDGE INSPECTION MANUAL

PART 2: TYPES OF INSPECTIONS

3. 456: Original road number. This number is omitted if the road number has never changed.
4. 78: Two-digit county code.
5. 91234: Five-digit structure number assigned by the Toll Authority according to the mileage east of the Illinois state line. The Toll Authority does not utilize any special conventions for bridges over or under railroads.
6. BCD: Structure designation like the state bridge numbers except the Indiana Toll Road does not assign letters to identify parallel structures or the number of rehabilitations a structure has undergone.

There are several Indiana Toll Road-owned and maintained bridges that were designed and built by the State which have bridge numbers like those used by the State. The majority of these are at the western end of the Toll Road, and at the two intersections with SR-912.

2-3.02(04) C o u n t y and Local Agency Bridge Numbers

County and local agency bridge numbers are supplied to INDOT by the County/County Consultant. This number is five digits and may contain letters. A “B” after the bridge number indicates the bridge is the second bridge at this location, using the same Bridge Number. A “C” indicates the third bridge, etc.

In order for a county/local bridge to be entered into BIAS, the county/consultant must as a minimum, supply INDOT the new bridge number, new NBI Number, Latitude, Longitude, Features Intersected, Facility Carried, and contract Number and Des# if let through INDOT. INDOT shall create the initial bridge file in BIAS using this information. It is recommended that on new bridges that Design Plans be provided to INDOT to create a new bridge in BIAS. This allows INDOT to enter more initial data when creating a new bridge.

2-3.03 Inside Indiana - County Border Inventory

For state bridges, inventory all bridges along or crossing the north and west borders of a county as being in that county. Inventory all bridges along or crossing the south and east borders of a county as being in the adjacent county.

For county bridges, inventory all bridges along or crossing the south and east borders of a county as being in that county. All bridges along or crossing the north and west borders of a county are inventoried in the adjacent county. See Indiana Code IC: 8-17-1-45(a).

2-3.04 State Line - County Border Inventory

BRIDGE INSPECTION MANUAL

PART 2: TYPES OF INSPECTIONS

For bridges along the state line borders, special agreements with the adjacent state/county may determine the ownership and maintenance responsibility of the bridges. Both INDOT and the FHWA shall review NBI Data on these county state line bridges annually and may meet periodically with local county officials from both states to ensure compliance with the NBIS.

All state line border bridges shall be inventoried in BIAS and reported to the FHWA annually. Bridges that an Indiana County has been designated as the lead county for inspections, shall submit each final inspection report to the adjacent state's county at least once a year, usually in February, so the data can be submitted to the FHWA. They should send a copy to INDOT, and/or IDOT/ODOT, depending on the state. Likewise on shared state line bridges that the neighboring state's county has been designated as the lead on inspections, they shall provide the Indiana County a copy of each report conducted at least once a year, usually in February, so the data can be submitted to the FHWA. The Indiana County shall provide this report to their inspection consultant that shall input this report and data into BIAS.

2-4.0 EMERGENCY NOTIFICATION/CRITICAL FINDINGS

2-4.01 Introduction

The procedures in this chapter set forth a uniform method for timely notification of serious bridge deficiencies that require an immediate response. They also document the baseline requirements for assuring that appropriate corrective or protective measures have been taken within a reasonable time frame and that established documentation protocol have been followed. Counties and other local government agencies may have additional guidelines for alternate route information, public relations, and information dissemination procedures that should be followed.

The procedures outlined in this chapter should be used to report conditions posing danger to persons or property or conditions that, if left unattended, would likely become such a danger.

This chapter outlines the responsibilities of the Inspection Team Leader, Inspection Consultants, District Inspection Engineers, and the State Program Manager in an emergency.

Any INDOT Approved Inspection Team Leader may close any bridge if it appears to be unsafe, or if they do so follow the guidelines.

2-4.02 Critical Findings

A critical finding is a structural or safety related deficiency that requires immediate follow-up inspection or action.

BRIDGE INSPECTION MANUAL

PART 2: TYPES OF INSPECTIONS

A structure-related deficiency can interrupt the load path, not allowing the loads to be transferred as designed. This can cause surrounding elements to become overstressed or unstable, potentially leading to partial or total collapse of the structure. Critical findings may also be non-structural deficiencies which jeopardize the safety of motorists or pedestrians.

The follow-up action may be a structural review to determine the strength or serviceability of an element or bridge.

2-4.02(01) P r o c e d u r e s for Inspectors

Upon identifying a potential critical finding, immediately report the deficiency to the appropriate agency officials. For non-state-owned bridges, the finding is to be first reported to the employee of responsible charge (ERC). The finding for state owned bridges and the second reporting for non-state-owned bridges is to be the State Program Manager (SPM).

The immediate actions taken by the inspector will vary with the circumstance. The inspector may close all or part of the structure until further analysis can be performed to determine the structural integrity of the structure. Alternatively, the inspector may recommend that remedial work be performed within a short time frame. Even if no immediate action is taken, it is still required to report the potential critical finding immediately, even in situations where the structural review will ultimately resolve the structure as having adequate strength.

The Inspector shall notify the State Program Manager at the time he reports a Critical Finding as to whether the Critical Finding is “Urgent” or “Severe”. An “Urgent” Critical Finding must have an action completed and the Critical Finding closed-out within 3-days of it being found. A “Severe” Critical Finding must have an action completed and the Critical Finding closed-out within 30-days of the Critical Finding being found. This longer time may be used to conduct a load rating, have signage made, or other items that cannot be done immediately.

All “Urgent” cases require the bridge to be either partially or fully closed immediately (within 24 hours) upon discovery of the defect.

“Urgent” cases require action(s) taken within 24-hours and “Severe” cases require actions(s) taken within 72 hours; however in unusual circumstances “Urgent” cases may be extended up to 72 hours (3-days) if approved by the SPM or ASPM. In addition, “Severe” cases may be extended up to 30 calendar days if approved by the SPM or ASPM.

In addition to the initial reporting of the potential critical finding, which may be verbal notification, a critical finding must be submitted in BIAS within 24 hours. On the Forms tab,

BRIDGE INSPECTION MANUAL

PART 2: TYPES OF INSPECTIONS

the last field is Critical Finding. The critical finding is created by clicking the plus symbol. Enter all the requested data and upload picture, sketches, and other related files. The workflow must be changed and assigned to the State Program Manager.

The State Program Manager will record the critical finding for tracking and will notify the FHWA in a timely manner. If further action is required, the SPM will change the workflow back to the inspector. Once the immediate safety concerns are addressed, the inspector will resubmit the critical finding back to the SPM for close out.

2-4.02(02) Documentation

Critical Findings must be documented in BIAS within 24 hours for all bridges. The Critical Finding will become a permanent record in the bridge file.

An ACTION must be recorded in the BIAS Critical Finding Report, along with photos attached, in order for the SPM to close-out a Critical Finding. This does not necessarily mean that the deficiency has been corrected. It just means that an action has been taken to address the immediate safety concerns. In BIAS, the inspector shall add a sentence in the Critical Finding Report, in the description of the issue, indicating whether the finding is “URGENT or SEVERE”

FIGURES

2-1.1: Bridge Inspection Types and Maximum Intervals

| Inspection Type | Maximum Inspection Interval | Agency |
|--------------------------|---|--------------|
| Initial | After Construction or Major Rehabilitation 90 Days | FHWA Mandate |
| Routine | 24 months | FHWA Mandate |
| Fracture Critical (92A)* | 24 months | FHWA Mandate |

BRIDGE INSPECTION MANUAL

PART 2: TYPES OF INSPECTIONS

| | | |
|-------------------|-------------|--------------|
| Routine | 48 months | INDOT Policy |
| Underwater (92B)* | 60 months | FHWA Mandate |
| Special (92C) | 60 months | INDOT Policy |
| In-Depth | 96 months | INDOT Policy |
| Damage | As needed | FHWA Mandate |
| Channel Survey | As required | INDOT Policy |
| Large Culvert | 60 months | INDOT Policy |

* Plan of action required

2-1.2: Summary of Underwater Inspection - Intensity Levels

| Level | Purpose | Typical Detectable Defects | | | |
|-------|--|---|---|--|--|
| | | Steel | Concrete | Timber | Composite |
| I | General visual/tactile inspection to confirm as-built condition and detect severe damage | Extensive corrosion and holes Severe structural damage | Major spalling and cracking Severe reinforcement corrosion Broken piles | Major loss of section Broken piles and bracings Severe abrasion or marine borer attack | Permanent deformation Broken piles Major cracking or structural damage |

BRIDGE INSPECTION MANUAL

PART 2: TYPES OF INSPECTIONS

| | | | | | |
|-----|--|---|--|---|--|
| II | To detect surface defects normally obscured by marine growth | Moderate structural damage Corrosion pitting and loss of section | Surface cracking, spalling, erosion Rust staining Exposed reinforcing steel and/or pre-stressing strands | External pile damage due to marine borers Splintered piles Loss of bolts and fasteners Rot or insect infestation | Cracking Delamination Material degradation |
| III | To detect hidden or interior damage, evaluate loss of cross-sectional area, or evaluate material homogeneity | Remaining thickness of material Electrical potentials for cathodic protection Change in material properties | Onset of reinforcing steel corrosion Internal voids Change in material properties | Internal damage due to marine borers (internal voids) Decrease in material strength Change in material properties | Change in material properties |

2-1.3: CREATING A REPORT IN BIAS

- Log into InspectTech and enter either the NBI number or last 4/5 digits of the structure number in the upper right corner where it says "Type Asset Name Here..."
- Click on the correct bridge

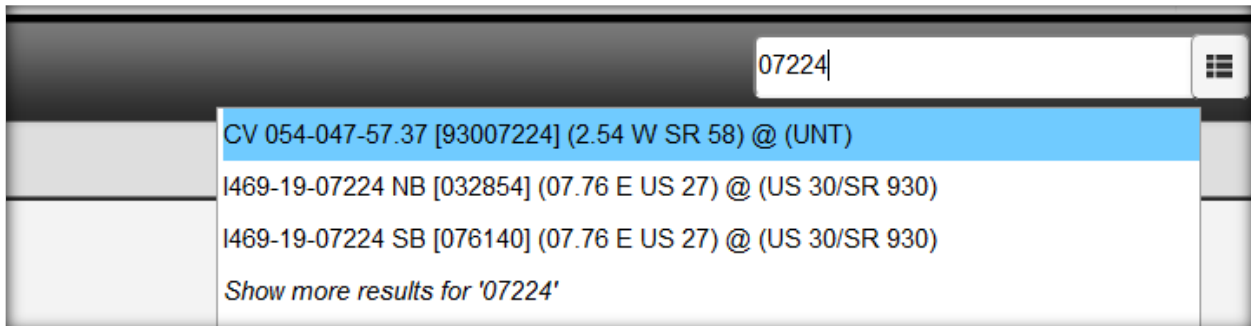

BRIDGE INSPECTION MANUAL

PART 2: TYPES OF INSPECTIONS

- After the page loads, click on “Create Report” in the upper right corner

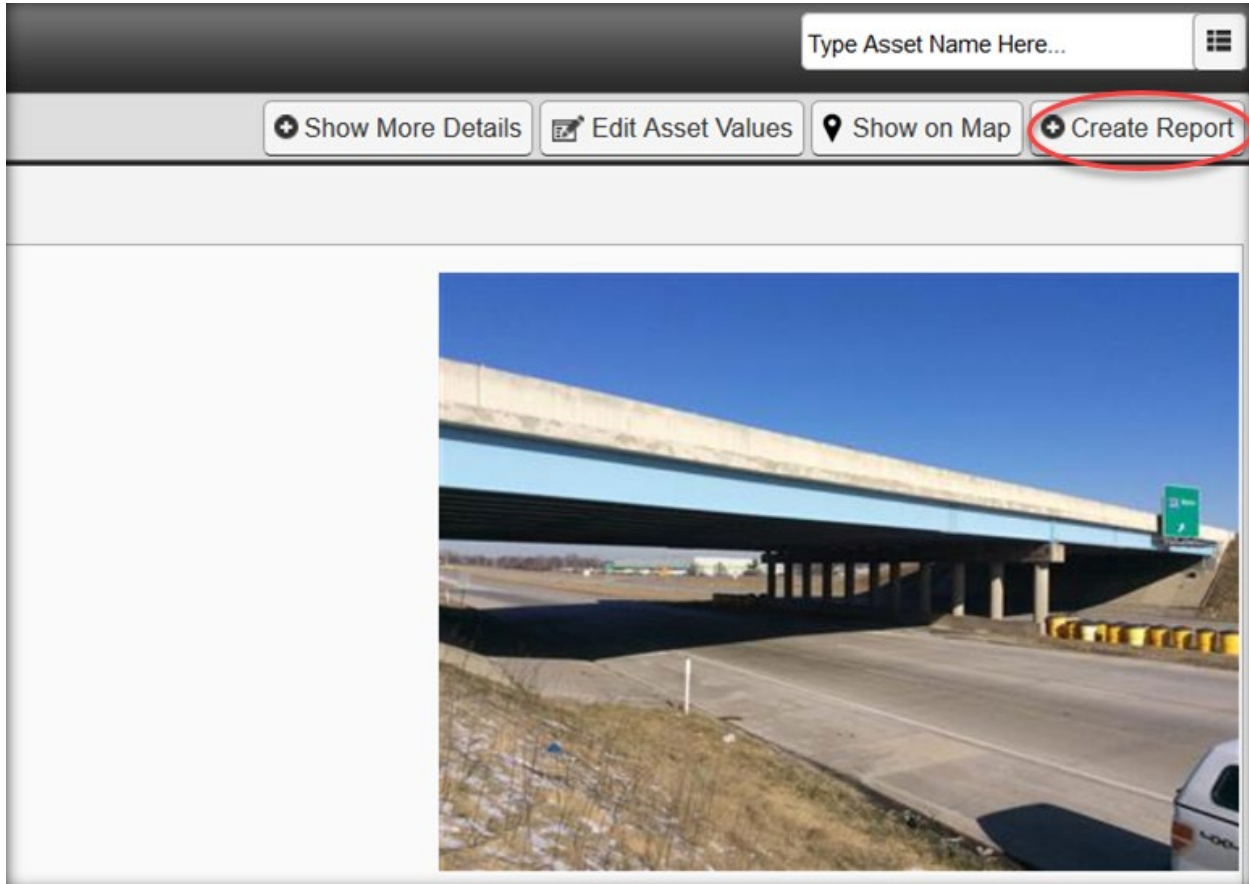

- Select the report type. Verify that “Asset Values” is selected
- Click “Create”

BRIDGE INSPECTION MANUAL

PART 2: TYPES OF INSPECTIONS

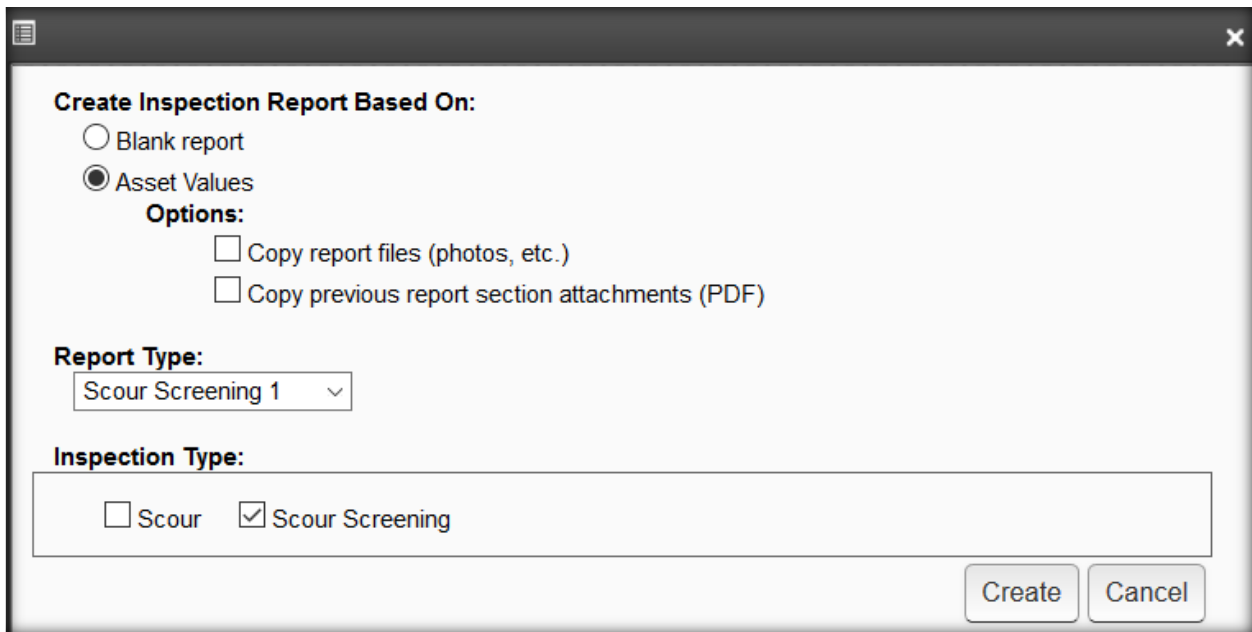

Create Inspection Report Based On:

Blank report

Asset Values

Options:

Copy report files (photos, etc.)

Copy previous report section attachments (PDF)

Report Type:

Scour Screening 1

Inspection Type:

Scour Scour Screening

Create Cancel

- **DO NOT USE the paperclip**, instead, go to the “Attach Picture/File” button

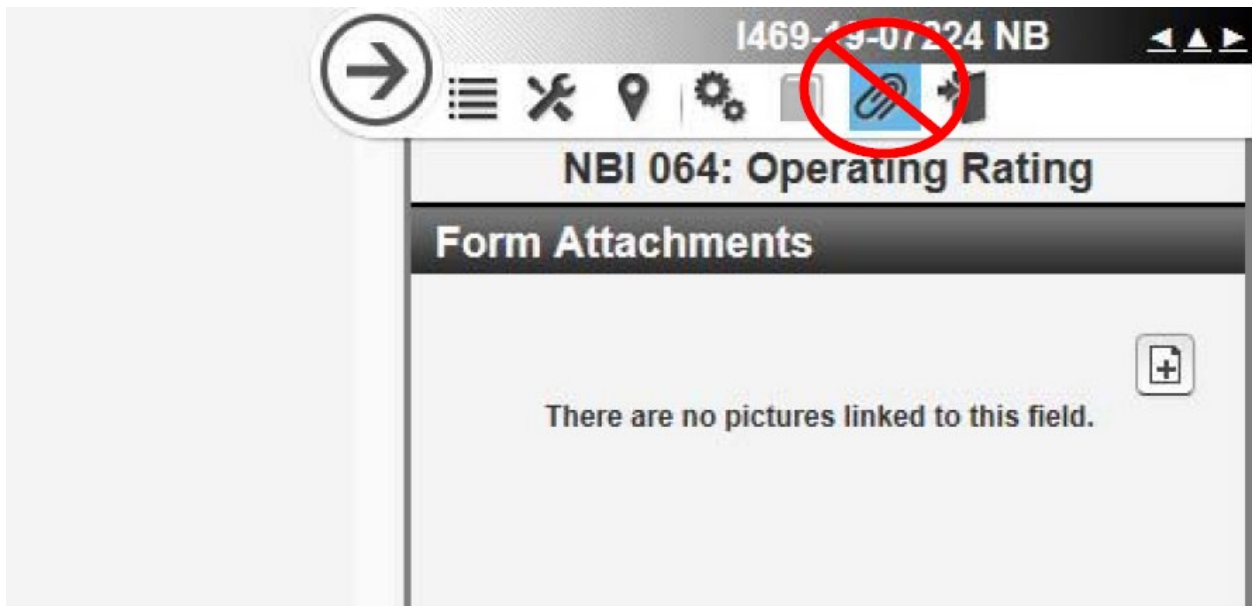

To attach supporting documentation to a report, click the icon to access the Forms.

- Click Report Sections
- Click “Add Sections/PDF Attachments” - “A”

BRIDGE INSPECTION MANUAL

PART 2: TYPES OF INSPECTIONS

- Click “Browse” to locate document – “B”
- Enter the document name. The name must use the Bridge File Document naming convention – “C”
- Once completed, click “Upload” – “D”

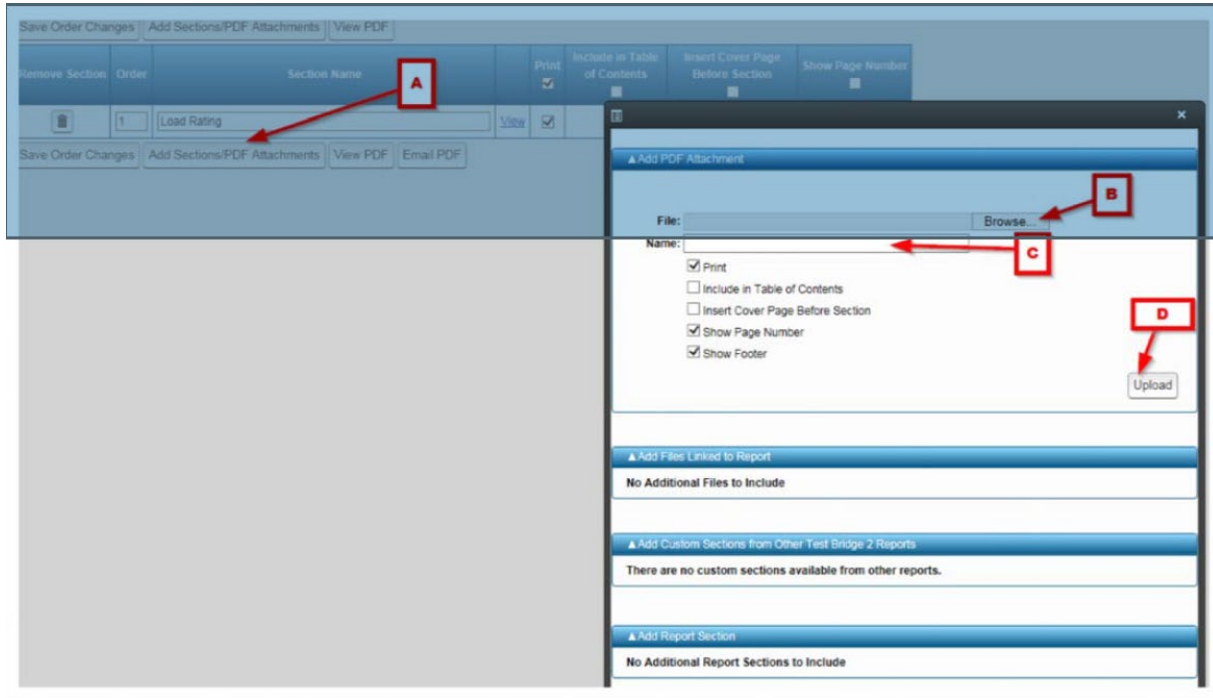

- Once the documentation has been attached, click on the wrench icon in the upper right corner of the screen, then “Submit Report for Review”

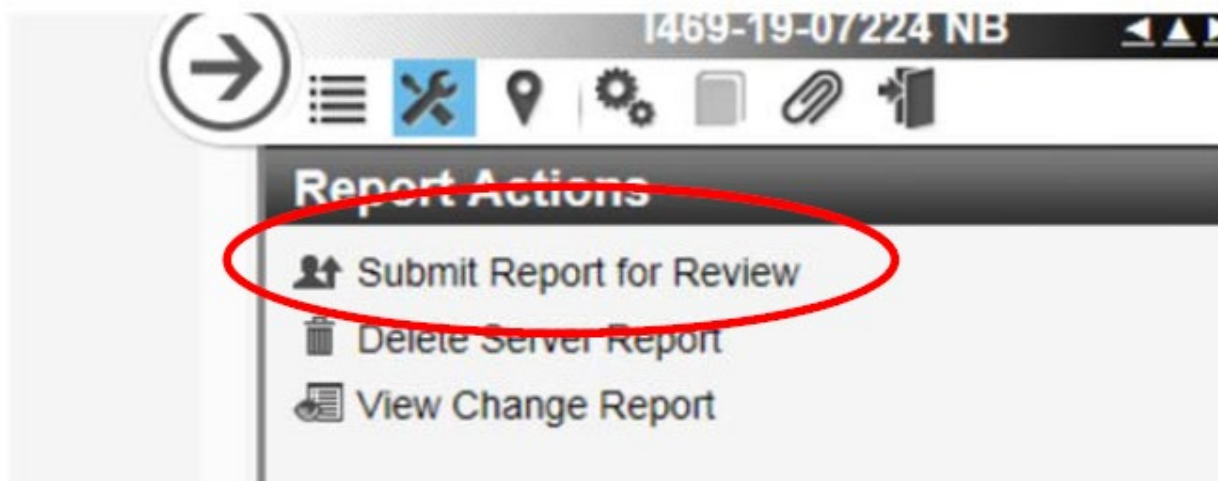

- Select “Data Entry Complete” as your workflow stage

BRIDGE INSPECTION MANUAL

PART 2: TYPES OF INSPECTIONS

- Select “Submit To” to send it to the person that needs to review the report
- Add a comment at each Workflow Stage
- Click “Submit”

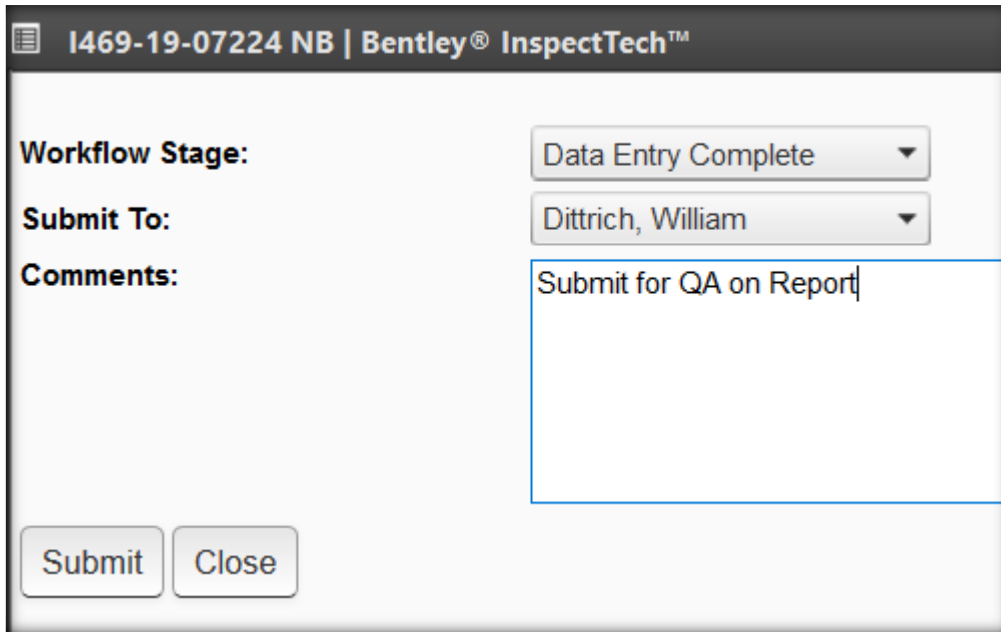

The screenshot shows the Bentley InspectTech interface for a workflow stage. The title bar reads "1469-19-07224 NB | Bentley® InspectTech™". The form includes the following fields:

- Workflow Stage:** A dropdown menu currently set to "Data Entry Complete".
- Submit To:** A dropdown menu currently set to "Dittrich, William".
- Comments:** A text area containing the text "Submit for QA on Report".

At the bottom of the form are two buttons: "Submit" and "Close".

2-1.4: REQUESTING ACCESS

New users must request access prior to uploading files to the Bridge File Documents folder in ERMS. From the ITAP main page, request a new application.

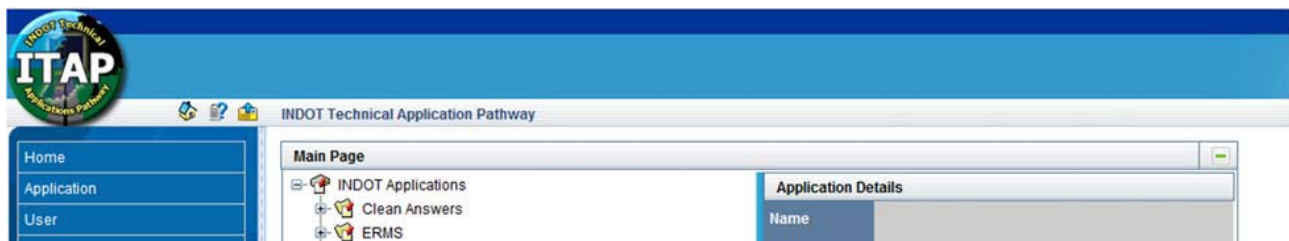

BRIDGE INSPECTION MANUAL

PART 2: TYPES OF INSPECTIONS

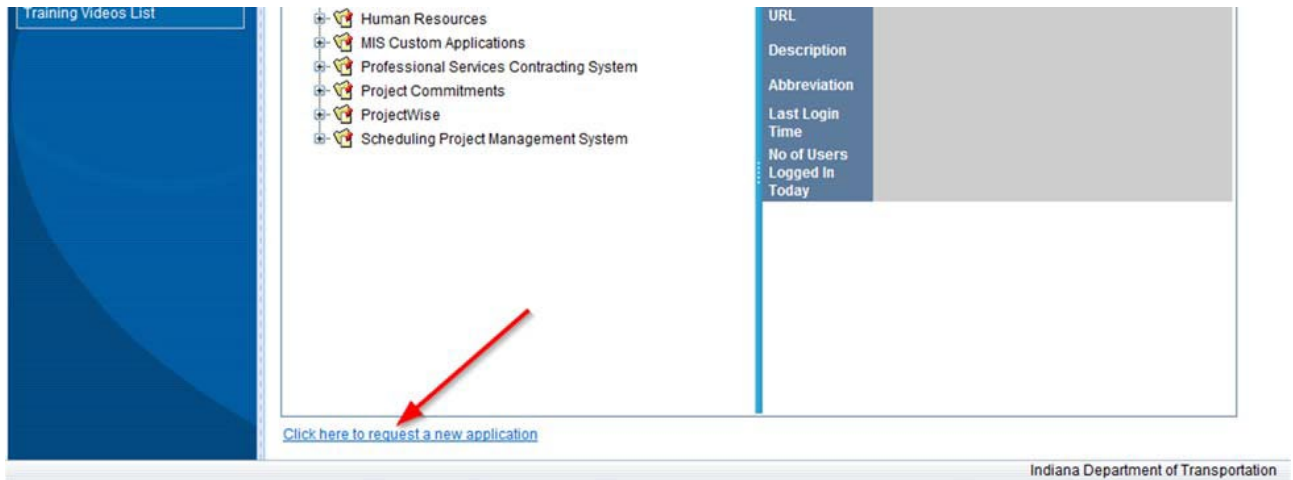

From the Application Enrollment screen, navigate to the Bridge File Documents application (ERMS – ARCHIVES – BRIDGE FILE DOCUMENTS). Select the appropriate role. Consultants should select “Bridge File Consultant”. INDOT personnel should select “Bridge File Author”. Click Submit. The user will be notified of approval via email.

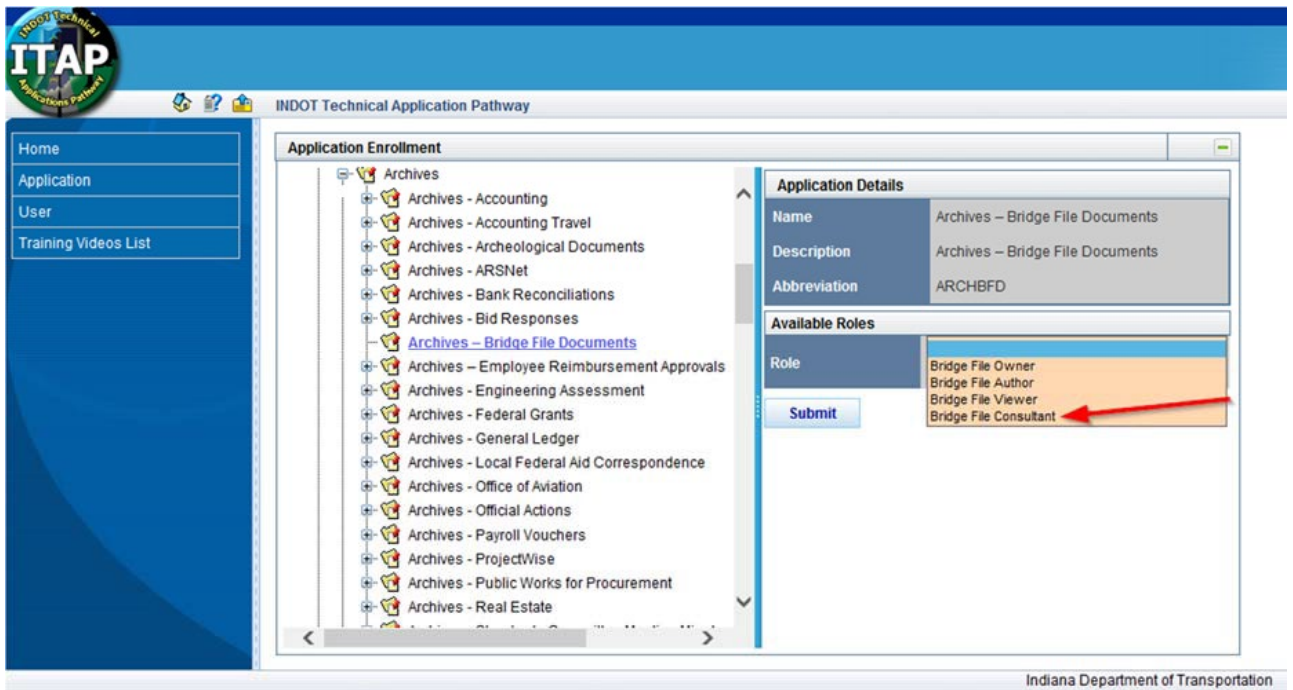

FILE NAMING CONVENTION

All files uploaded to the Bridge File Documents folder within ERMS Bridge File must use the following naming convention. The file naming convention for various document types and their corresponding abbreviations is available from the INDOT Bridge Inspection webpage.

[Document Type Abbrev.] [Bridge Number] - [Document Date]

BRIDGE INSPECTION MANUAL

PART 2: TYPES OF INSPECTIONS

Notes:

Plans and Inspection Reports will have a supplemental description

Include the dash between the Bridge Number and the Document Date

Document Date is the date on the document itself, not the date the document was uploaded.

Document date must use dashes “-“not slashes “/”.

Examples:

Original Plans = Plans O 056-88-01478 - 9-28-1933.pdf

Hydraulic Memo = HydroMemo 056-88-01478 - 01-01-2002.pdf

Load Rating Model = LoadRtgMdl I69-263-04764 CNB - 01-01-2015.xml*

Load Rating Summary (County Bridge) = LoadRtgSum 52-00035 - 01-01-2016*

* Upload in ERMS for BRADIN

USING THE MULTIPLE FILE UPLOAD TOOL

1. (From ITAP) ERMS – Archives – Archives – Bridge File Documents. Selection the File Upload URL link

The screenshot shows the 'INDOT Technical Application Pathway' interface. On the left, a navigation tree under 'Main Page' includes 'INDOT Applications' with sub-items like 'CES Consultant Access', 'Clean Answers', 'Electronic Permit System', 'ERMS', 'Archives', 'Archives – Bridge File Documents', 'Construction Changes Document Management System', and 'Design Submittals - New'. A red arrow points from 'Archives – Bridge File Documents' to the 'Application Details' panel on the right. The 'Application Details' panel shows:

| Application Details | |
|---------------------|--|
| Name | Archives – Bridge File Documents |
| UCM URL | Click here to access application |
| File Upload URL | Click here to access application |
| Description | Archives – Bridge File Documents |
| Abbreviation | ARCHBFD |

2. Select “Bridge File Documents”
3. Select the document to be uploaded (drag and drop)
4. Click “Start Upload” then “OK” when done
5. Click “Enter File Information”

The screenshot shows the 'Select files' upload tool interface. At the top, it says 'Please choose the desired type of document :' with a dropdown menu set to 'Bridge File Documents'. A red arrow labeled '2.' points to the dropdown. Below this is a table with columns 'Filename', 'Status', and 'Size'. The table contains one entry: 'Plans O 056-88-01478 - 9-28-1933.pdf' with a size of '2.1 mb'. A red arrow labeled '3.' points to the filename, with a note below it: 'file name must use required'.

BRIDGE INSPECTION MANUAL

PART 2: TYPES OF INSPECTIONS

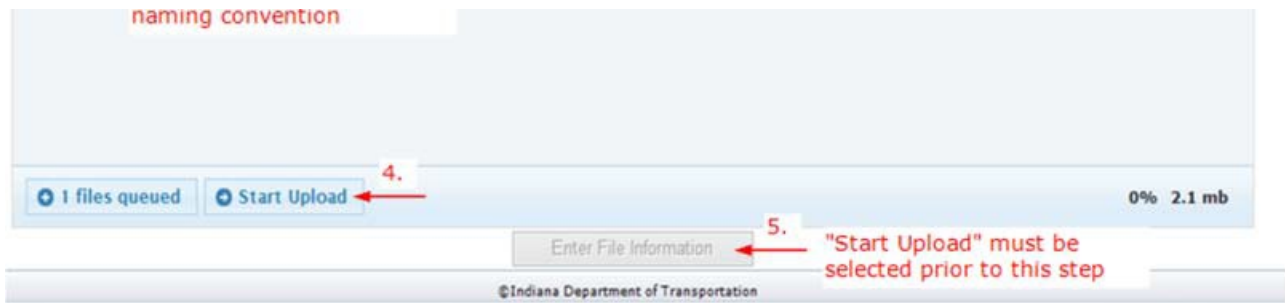

6. Information entered on following screen will be applied to all files uploaded. The following fields must be completed prior to adding files to ERMS. Values must be consistent with those shown in BIAS.

- Structure Number
- Document Type
- NBI number
- County

The screenshot shows the "Enter File Information" form. At the top, there is a field for "Enter DES number:" with a "Fill from SPMS" button. Below this, the form is divided into two sections: "Required Properties" and "Optional Properties". The "Required Properties" section includes a "Structure Number" field with a dropdown menu showing "169-263-04764 CNB" and a "Document Type" dropdown menu showing "Load Rating Model". The "Optional Properties" section includes fields for "NBI Number", "County", "Year Built", "Facility Carried", "Feature Intersected", "Document Date", and "District". A "Next" button is located at the bottom of the form. At the bottom of the interface, there is a footer with the text "©Indiana Department of Transportation".

7. Click "Next"

8. Click on each uploaded file and enter all information that was not input during Step 6. Select the document Type from the pull down menu. The Document Type should match the Document Type Description from the file naming convention, except that all plans should use "Plans" and all bridge inspection reports should use "Bridge Inspection". Verify that the document type matches the specific file being uploaded.

9. When done with all prior steps, click "Add Files to ERMS".

10. When the confirmation screen appears, close the browser

BRIDGE INSPECTION MANUAL

PART 2: TYPES OF INSPECTIONS

Files Uploaded

- <*> LoadRtgMdl 169-263-04764
- <*> LoadRtgSum 169-263-04764

Required Properties

Document Type : Load Rating Model

Structure Number : click "+" sign to add values

Optional Properties

NBI Number :

County :

Year Built :

Facility Carried :

District :

Feature Intersected :

[Previous](#) [Next](#)

[Add Files to ERMS](#)

INDOT BRIDGE INSPECTION MANUAL

PART 3

LOAD RATING

| Inspection Memorandum | Revision Date | Sections Affected |
|------------------------------|----------------------|--------------------------|
| 18-01 | Apr. 2018 | 3-9.02(01), 3-9.02(02) |

The revision date is noted in brackets next to the heading for each affected section.

INDOT BRIDGE INSPECTION MANUAL

PART 3: LOAD RATING

TABLE OF CONTENTS

| | |
|---|----|
| TABLE OF CONTENTS | 2 |
| LIST OF FIGURES | 4 |
| 3-1.0 INTRODUCTION | 5 |
| 3-2.0 REFERENCE MATERIAL..... | 5 |
| 3-3.0 ROLES & RESPONSIBILITIES..... | 6 |
| 3-3.01 Bridge Owner | 6 |
| 3-3.02 Indiana Department of Transportation | 7 |
| 3-3.03 Load Rating Engineer | 7 |
| 3-4.0 VEHICLES..... | 7 |
| 3-4.01 Design..... | 7 |
| 3-4.02 Legal [Rev. Oct. 2018] | 8 |
| 3-4.03 Permit..... | 9 |
| 3-5.0 METHODS..... | 10 |
| 3-5.01 Analytical..... | 10 |
| 3-5.01(01) Load and Resistance Factor Rating (LRFR)..... | 11 |
| 3-5.01(02) Load Factor Rating (LFR)..... | 12 |
| 3-5.01(03) Other | 12 |
| 3-5.02 Engineering Judgment [Rev. Oct. 2018] | 12 |
| 3-6.0 POSTING..... | 13 |
| 3-6.01 Load and Resistance Factor Rating Analysis..... | 14 |
| 3-6.02 Load Factor Analysis..... | 14 |
| 3-6.03 Engineering Judgment | 14 |
| 3-6.04 Regulatory Signage [Rev. Apr. 2019] | 15 |
| 3-7.0 DOCUMENTATION..... | 16 |
| 3-8.0 QUALITY CONTROL (QC) & QUALITY ASSURANCE (QA) | 17 |
| 3-9.0 PROCEDURE..... | 17 |
| 3-9.01 Frequency..... | 17 |
| 3-9.01(01) Project Scoping..... | 18 |
| 3-9.01(02) New, Replacement, or Rehabilitated Structures..... | 18 |
| 3-9.01(03) Deterioration | 18 |
| 3-9.01(04) Critical Findings..... | 19 |
| 3-9.01(05) Repairs | 19 |
| 3-9.01(06) Permitting..... | 20 |

INDOT BRIDGE INSPECTION MANUAL

PART 3: LOAD RATING

| | | |
|------------|---|----|
| 3-9.02 | Submittal Process & Notification..... | 20 |
| 3-9.02(01) | General [Rev. Apr. 2018]..... | 20 |
| 3-9.02(02) | Posting [Rev. Apr. 2018] | 21 |
| 3-10.0 | MODELING GUIDELINES & ASSUMPTIONS | 21 |
| 3-11.0 | APPENDICES | 22 |
| 3-11.1 | Appendix A: Vehicle Configurations..... | 22 |
| 3-11.2 | Appendix B: Extra-Heavy Duty Highways | 36 |
| 3-11.3 | Appendix C: Load Rating Report Documentation Examples [Rev. Oct. 2018]..... | 36 |
| 3-11.4 | Appendix D: Regulatory Sign Details [Added Apr. 2019]..... | 36 |

INDOT BRIDGE INSPECTION MANUAL

PART 3: LOAD RATING

LIST OF FIGURES

| <u>Figure</u> | <u>Title</u> | |
|----------------------|--|----|
| Figure 3-4.1 | Potential Design Vehicles | 8 |
| Figure 3-4.2 | Required Legal Vehicles | 9 |
| Figure 3-4.3 | Potential Permit Vehicles | 10 |
| Figure 3-9.1 | BIAS ERMS Link to the Bridge File..... | 21 |
| Figure A-1 | HL-93 Loading | 22 |
| Figure A-2 | Fatigue Loading | 23 |
| Figure A-3 | H-20 Loading..... | 24 |
| Figure A-4 | HS-20 Loading..... | 25 |
| Figure A-5 | HS-25 and Alternate Military Loading | 26 |
| Figure A-6 | Toll Road Truck Loads | 27 |
| Figure A-7 | Michigan Train Truck Loads..... | 28 |
| Figure A-8 | Superload Vehicle Loads..... | 29 |
| Figure A-9 | Superload Vehicle Loads..... | 30 |
| Figure A-10 | AASHTO Legal Loads..... | 31 |
| Figure A-11 | Lane-Type Loading..... | 32 |
| Figure A-12 | FAST Act EV Loads..... | 33 |
| Figure A-13 | Notional Rating Load (NRL)..... | 34 |
| Figure A-14 | Specialized Hauling Vehicles (SHV)..... | 35 |

INDOT BRIDGE INSPECTION MANUAL

PART 3: LOAD RATING

3-1.0 INTRODUCTION

The primary purpose of this part of the manual is to establish a uniform policy of load rating procedures and standards for determining the safe load carrying capacity of bridges within the state of Indiana. This part is heavily influenced by the guidelines established in Section 6 of the *Manual for Bridge Evaluation*, 2nd Edition, which includes all interim revisions. Any variance with these guidelines is discussed in the sections to follow. At no point shall the requirements set forth in this document conflict with state or federal law. In the event of discrepancy, the law shall apply.

3-2.0 REFERENCE MATERIAL

AASHTO. (2008). *The Manual for Bridge Evaluation* (1st ed.). Washington, DC: American Association of State Highway and Transportation Officials.

AASHTO. (2011 with 2011, 2013, 2014, 2015, and 2016 Interim Revisions). *The Manual for Bridge Evaluation* (2nd ed.). Washington, DC: American Association of State Highway and Transportation Officials.

**References to the MBE in this manual refer to the 2nd Edition and its Interim Revisions. However, 23 CFR 650.317 references the 1st Edition, making this the binding edition. **

AASHTO. (2002). *Standard Specifications for Highway Bridges* (17th ed.). Washington, DC: American Association of State Highway and Transportation Officials.

AASHTO. (2014 with 2015 and 2016 Interim Revisions). *AASHTO LRFD Bridge Design Specifications* (7th ed.). Washington, DC: American Association of State Highway and Transportation Officials.

Vehicle weight limitations – Interstate System, 23 U.S.C. 127 (2017)

National Bridge Inspection Standards, 23 CFR 650 subpart C (2016)

Hartmann, Joseph L. (November 3, 2016). *Load Rating for the FAST Act's Emergency Vehicles*. Washington, DC: U.S. Department of Transportation, Federal Highway Administration, Office of Bridges and Structures.

INDOT BRIDGE INSPECTION MANUAL

PART 3: LOAD RATING

FHWA. (March 2017). *QUESTIONS AND ANSWERS Load Rating for the FAST Act's Emergency Vehicles*. Washington, DC: U.S. Department of Transportation, Federal Highway Administration, Office of Bridges and Structures.

Size and Weight Regulation, IC 9-20 (2017)

Indiana Department of Transportation. (September 2011). *Bridge Inspection Program Coding Guide, Bridge Reporting for Appraisal & Greater Inventory* (Vols. 1-3)

(2011 with Revisions 1, 2, and 3). *Indiana Manual on Uniform Traffic Control Devices for Streets and Highways*. <http://www.in.gov/dot/div/contracts/design/mutcd/2011rev3MUTCD.htm>

Indiana Department of Transportation. (2013-2017). *Indiana Design Manual*. http://www.in.gov/indot/design_manual/design_manual_2013.htm

3-3.0 ROLES AND RESPONSIBILITIES

Load rating roles for bridge owners, the Indiana Department of Transportation, and load rating engineers are described below.

3-3.01 Bridge Owner

Bridge owners in Indiana include the state, counties, other local agencies, toll roads, and private firms owning bridges open to public traffic. For bridges within their authority, bridge owners are responsible for the following items:

- Ensuring all bridges within their jurisdiction are load rated for their in-service condition.
- Ensuring that new, replacement, or rehabilitated bridges are load rated no later than the initial inspection.
- Quality control and maintaining of all required load rating documentation.
- Posting of bridges as required.

INDOT BRIDGE INSPECTION MANUAL

PART 3: LOAD RATING

3-3.02 Indiana Department of Transportation

The Indiana Department of Transportation (INDOT) is responsible for ensuring bridge owners are in compliance with the *National Bridge Inspection Standards* (NBIS) as given in 23 CFR 650 Subpart C, Bridges, Structures, and Hydraulics.

3-3.03 Load Rating Engineer

Qualifications for a load rating engineer (LRE) are discussed in Part 1 of this manual. LREs must certify and be actively involved in reviewing the quality and accuracy of all load ratings performed. A qualified LRE is also responsible for submitting all required documentation as specified in 3-9.02.

3-4.0 VEHICLES

Vehicles are classified into three main subcategories: design, legal, and permit. Each of these categories is discussed in greater detail below. Vehicle configurations are shown in Appendix A.

3-4.01 Design

Design vehicles are live loads used for the purpose of designing new, replacement, or rehabilitation bridge projects. Applicable design vehicles are listed on the plans for which the structural element in question was designed. Rules regarding the applicability of design vehicles are specified in the *Indiana Design Manual* (IDM). See Figure 3-4.1 for a list of potential design vehicles. Additionally, rating factors at the Design Inventory Level for both the H-20 and HS-20 vehicles shall reflect the existing condition of the bridge as required by the Federal Highway Administration (FHWA). Furthermore, general Toll Road and Michigan Train Truck applicability is discussed below as well as in IDM 403-3.01.

Any bridge on the Indiana Toll Road or any state owned or maintained bridge within 15 miles of a toll road gate shall be rated for the Toll Road Truck configurations including a 0.64 klf lane load. Any bridge located on the Extra-Heavy-Duty Highway, as described in IC 9-20-5-4, shall be rated for the Michigan Train Truck configurations including a 0.64 klf lane load. See Appendix B for supplementary information regarding the Indiana Toll Road and Extra Heavy-Duty Highways.

INDOT BRIDGE INSPECTION MANUAL

PART 3: LOAD RATING

| Truck Configuration |
|-------------------------|
| HL-93 |
| Fatigue* |
| H-20 |
| HS-20 |
| HS-25 |
| Alternate Military |
| Toll Road Loading No. 1 |
| Toll Road Loading No. 2 |
| Special Toll Road Truck |
| Michigan Train Truck #5 |
| Michigan Train Truck #8 |

* The Fatigue configuration shall be used for evaluating the Fatigue Limit State per MBE Table 6A.4.2.2-1 whenever HL-93 is specified on applicable plans

Figure 3-4.1 Potential Design Vehicles

3-4.02 Legal [Rev. Oct. 2018]

Legal vehicles are live loads that are used for the sole purpose of determining the safe load carrying capacity and posting of a bridge. This legal category is described in the Manual for Bridge Evaluation (MBE) section 6A.4.4 for Load and Resistance Factor Rating (LRFR) and 6B.7.2 for Load Factor Rating (LFR). Every bridge in Indiana is required to be rated for the vehicles listed in Figure 3-4.2; any vehicle not explicitly mentioned in the MBE shall be considered a “state legal load” as discussed in the MBE. For LRFR, the vehicles are broken down into two subcategories, Routine Commercial Traffic and Specialized Hauling.

Routine Commercial Traffic contains vehicles that represent typical commercial trucking configurations that are also encompassed by the Federal Bridge Formula. In addition to these vehicles are emergency vehicles, EV2 and EV3, required by 23 U.S.C. 127 and provided by the FHWA. The emergency vehicles should be considered to occupy a single lane only and one-lane distribution should be used to represent the low probability of these vehicle types being located adjacent to other heavily loaded vehicles. In addition, a live load factor of 1.3 should be used for emergency vehicles, regardless of the ADTT.

INDOT BRIDGE INSPECTION MANUAL

PART 3: LOAD RATING

Specialized Hauling contains single unit, short wheelbase, multiple axle trucks typical of construction, waste management, and bulk cargo/commodities hauling industries. These configurations are also encompassed by the Federal Bridge Formula.

| Truck Configuration | LRFR Subcategory |
|---------------------|----------------------------|
| H-20 | Routine Commercial Traffic |
| HS-20 | Routine Commercial Traffic |
| Alternate Military | Routine Commercial Traffic |
| AASHTO Type 3 | Routine Commercial Traffic |
| AASHTO Type 3S2 | Routine Commercial Traffic |
| AASHTO Type 3-3 | Routine Commercial Traffic |
| Lane-Type* | Routine Commercial Traffic |
| EV2 | Routine Commercial Traffic |
| EV3 | Routine Commercial Traffic |
| NRL** | Specialized Hauling |
| SU4 | Specialized Hauling |
| SU5 | Specialized Hauling |
| SU6 | Specialized Hauling |
| SU7 | Specialized Hauling |

* Load and Resistance Factor Rating (LRFR) only

** Not to be used for load posting

Figure 3-4.2 Required Legal Vehicles

3-4.03 Permit

Permitted vehicles are live loads that exceed legal load limitations. These vehicles can be issued routine or special permits. Vehicles for which routine permits are commonly issued shall be used for determining the safe load capacity and posting of a bridge. Special permits are for less frequent loads and often with additional limitations. Permit load rating is discussed in MBE 6A.4.5 for Load and Resistance Factor Rating (LRFR) and MBE 6B.8 for Load Factor Rating (LFR). See Figure 3-4.3 for a list of potential permit vehicles.

Any bridge on the Indiana Toll Road or any state owned or maintained bridge within 15 miles of a toll road gate shall be rated for the Toll Road Truck configurations. Any bridge located on the Extra-Heavy-Duty Highway, as described in IC 9-20-5-4, shall be rated for the Michigan Train Truck configurations. It is acceptable to limit Michigan Train Truck vehicles to one lane located

INDOT BRIDGE INSPECTION MANUAL

PART 3: LOAD RATING

so as to cause extreme force effects while the other lanes are occupied by regular legal loads. A lane load shall be included with all Toll Road or Michigan Train Truck configurations if required by the MBE depending on rating method and bridge geometry. See Appendix B for supplementary information regarding the Indiana Toll Road and Extra Heavy-Duty Highways.

Where analytical rating methods are used on state owned or maintained bridges, the “Special” vehicles, as shown in Figure 3-4.3 below, shall be evaluated. These “Special” vehicles shall be single trip, mixed with traffic, and without reduction in speed.

| Routine | Special |
|-------------------------|--------------------------------|
| Toll Road Loading No. 1 | Superload – 11 Axles |
| Toll Road Loading No. 2 | Superload – 13 Axles |
| Special Toll Road Truck | Superload – 14 Axles |
| Michigan Train Truck #5 | Superload – 19 Axles (305K) |
| Michigan Train Truck #8 | Superload – 19 Axles (480.09K) |

Figure 3-4.3 Potential Permit Vehicles

3-5.0 METHODS

Analytical methods shall be used for load rating whenever possible. Engineering judgement may be used to supplement calculations. If necessary, bridge geometry or material properties are not available and cannot be obtained economically, then engineering judgment may be used in place of analytical methods. In addition, bridge owners have the right to add conservativeness at their discretion; this can mean posting the bridge at a lower tonnage than required by analysis.

3-5.01 Analytical

The two primary analytical methods are Load and Resistance Factor Rating (LRFR) and Load Factor Rating (LFR). The department’s vehicle classifications as defined in Section 3-4 most closely align with LRFR but still apply to LFR as well. An important distinction between the two methodologies is their definition of Inventory and Operating ratings.

As discussed in the MBE for LRFR, Inventory and Operating ratings are subcategories to the Design Load Rating category. Values for this category are required when construction work is proposed that will change the structural behavior or capacity of the bridge. For state owned or maintained bridges rated LRFR, only Inventory values are required when evaluating for design

INDOT BRIDGE INSPECTION MANUAL

PART 3: LOAD RATING

loads; Operating values will only be considered on a case by case basis. For LFR, Inventory corresponds to Design Load Rating and Operating to Legal Load Rating.

Regardless of method, the Legal Load category is always required whenever a load rating is performed. This means that Operating ratings are only required for LFR since they fall under the Design category for LRFR.

LRFR shall be used for any new or replacement superstructure. For state owned or maintained bridges, LRFR shall be used regardless of the original design method. In certain situations, LRFR is more restrictive than what earlier design codes required. This can lead to overly conservative ratings for existing structures that are performing well. In these situations, other rating methods may be considered. See Section 3-10.1 for additional details. Any situation not listed in 3-10.1 will require the approval of the INDOT load rating staff.

AASHTOWARE Bridge Rating “BrR” shall be used to perform load ratings whenever possible. It is permissible to use other programs and/or engineering judgment in cases where the use of BrR is insufficient or not plausible due to program limitations. Additional resources are available on the bridge design website including a list of programs that may be used to supplement BrR.

3-5.01(01) Load and Resistance Factor Rating (LRFR)

Load and Resistance Factor Rating (LRFR) analysis shall follow the procedures outlined in MBE Section 6A except as noted in this manual. As defined in this manual and discussed in the MBE, ratings fall into three categories, Design Load, Legal Load, and Permit Load. Please refer to Section 3-4 in this manual for a list of vehicles that fall within each category and a discussion regarding their applicability. In short, for determining the load capacity or safe posting load of a bridge, all vehicles within the Legal Load category and applicable vehicles designated as Routine Permit are required.

As discussed in MBE 6A.5.4 and with the exception of segmentally constructed bridges, service limit states in regards to crack control should not be considered for determining the load capacity or safe posting load of state owned or maintained reinforced concrete or prestressed concrete in-service bridge components. Crack control may be considered for determining the load capacity or safe posting load for local bridges at the discretion of the owner. This applies to both legal and routine permit loads. For special permit evaluation, use of these provisions is at the discretion of the permitting engineer. Crack control is a means for ensuring longevity of the structure and is therefore most applicable for design loading.

INDOT BRIDGE INSPECTION MANUAL

PART 3: LOAD RATING

The condition factor Φ_C and system factor Φ_S shall be used per MBE 6A.4.2.3 & 6A.4.2.4 respectively. Where material properties are unknown, assumptions can be made per MBE 6A.5.2. Regarding MBE 6A.5.8, if the conditions of this article are met for reinforced concrete slab bridges, shear capacity need not be checked for design and legal loads. Similarly, shear need not be evaluated for any proposed work on reinforced concrete slab bridges. For any other reinforced, prestressed, or post-tensioned concrete bridge, the shear capacity shall always be evaluated for design, legal, and permit ratings regardless of condition or distress. When shear controls, refined analysis may be used to more accurately model boundary conditions and loading scenarios.

3-5.01(02) Load Factor Rating (LFR)

Load Factor Rating (LFR) analysis shall follow the procedures outlined in MBE 6B except as noted in this manual. As defined in this manual, ratings fall into three categories, Design Load, Legal Load, and Permit Load. Please refer to Section 3-4 in this manual for a list of vehicles that fall within each category and a discussion regarding their applicability. In short, for determining the load capacity or safe posting load of a bridge, all vehicles within the Legal Load category and applicable vehicles designated as Routine Permit are required. When referencing MBE 6B, Inventory is equivalent to Design Load and Operating is equivalent to both Legal Load and Permit Load.

3-5.01(03) Other

If the LRFR method is not used, bridges designed by the Allowable or Working Stress Method should be rated LFR, see Section 3-5.01(02).

3-5.02 Engineering Judgment [Rev. Oct. 2018]

MBE 6.1.4 discusses the use of engineering judgment in place of or as a supplement to analytical methods when necessary details to load rate are missing or incomplete.

Load rating based on engineering judgement may be used in lieu of analytical methods only when there are no plans or details available and physical measurement of the structural members is not possible, such as the reinforcing bars of a concrete structure. The LRE should consider all available information when determining the load rating, including, but not limited to:

- Year of construction and common material properties for that time period,
- assumed design vehicle,

INDOT BRIDGE INSPECTION MANUAL

PART 3: LOAD RATING

- all measurable structure dimensions,
- redundancy of load path,
- deterioration levels,
- signs of distress such as transverse cracks in high moment regions or diagonal cracks in high shear regions, and
- changes to the structure such as increased dead loads since original construction.

The load rating shall be determined for all vehicles described in Section 3-4.0. Consideration should be given to the size and configuration of vehicles that routinely use the bridge being evaluated. A comparison of shear and moments produced by vehicles that routinely use the bridge to those produced by load rating vehicles that may not routinely use the bridge may aid the Engineer in determining appropriate rating factors.

Engineering judgment may be used to assign lower ratings than computed at the owner's request or to increase conservativeness when desired.

3-6.0 POSTING

Bridges that cannot safely carry legal or applicable state routine permit loads, as defined in Section 3-4, must be posted. This is represented by a legal or routine permit rating factor of less than 1.0 for any of the required vehicles. Posting for design loads is conservative and therefore will only be allowed at the discretion of the bridge owner.

If **any** legal or applicable state routine permit vehicle rates below 1.0, then the bridge shall be posted for the safe posting load of **all** required vehicles; this applies to each vehicle even if it rates higher than 1.0. This is necessary because although only one vehicle may actually fall below the 1.0 rating factor threshold, the calculated load capacity or safe posting load may in fact be higher than a different legal vehicle that has a lighter gross vehicle weight.

Example:

Vehicle 1 (4-Axle, GVW = 38 Tons)

- Legal Rating Factor = 0.9 → Safe Posting Load = 34 Tons

Vehicle 2 (4-Axle, GVW = 26 Tons)

- Routine Permit Rating Factor = 1.1 → Safe Posting Load = 28 Tons

Based on the example above, even though Vehicle 2 has a higher rating factor than Vehicle 1, Vehicle 2 still has the lower safe posting load. Therefore, it would be unsafe to post the bridge for

INDOT BRIDGE INSPECTION MANUAL

PART 3: LOAD RATING

34 tons. Rating vehicles can be grouped together by the number of axles to determine the lowest tonnage for each group; see Section 3-6.04 for acceptable signage.

3-6.01 Load and Resistance Factor Rating Analysis

Where analytical models have been developed consistent with Section 3-5.01(01), load posting criteria shall conform to MBE 6A.8 except as noted below. The load capacity is determined according to MBE 6A.4.4.4. For rating factors below 1.0, the safe posting load is determined according to MBE 6A.8.3. For rating factors greater than or equal to 1.0, the safe posting load is equivalent to the load capacity.

All applicable AASHTO, state legal, and routine permit loads listed in the MBE and Section 3-4 in this manual shall be evaluated for posting purposes. The NRL “notional load” shall not be used as justification for ignoring the AASHTO Specialized Hauling Vehicles.

3-6.02 Load Factor Analysis

Where analytical models have been developed consistent with Section 3-5.01(02), load posting criteria shall conform to MBE 6B.7 except as noted below. The load capacity is determined according to MBE 6B.4.1. The safe posting load calculation is equivalent to the load capacity and further discussed in MBE 6B.7.3.

All applicable AASHTO, state legal, and routine permit loads listed in the MBE and Section 3-4 in this manual shall be evaluated for posting purposes. The NRL “notional load” shall not be used as justification for ignoring the AASHTO Specialized Hauling Vehicles.

3-6.03 Engineering Judgment

Where engineering judgment is warranted per Section 3-5.02, the load posting criteria shall conform to Section 3-6.02.

All applicable AASHTO, state legal, and routine permit loads listed in the MBE and Section 3-5 in this manual shall be evaluated for posting purposes. The NRL “notional load” shall not be used as justification for ignoring the AASHTO Specialized Hauling Vehicles.

INDOT BRIDGE INSPECTION MANUAL

PART 3: LOAD RATING

3-6.04 Regulatory Signage [Rev. Apr. 2019]

There are multiple options for restricting vehicle weight. At a minimum, restrictions shall be for gross vehicle weight. At the discretion of the bridge owner, restrictions may be further refined by listing multiple gross vehicle weight restrictions based on the corresponding number of axles for all legal vehicles and for routine permit vehicles (where applicable). Posting for maximum permissible axle weights may be appropriate for short span bridges or critical bridge elements such as floor beams or stringers. Under no circumstances shall a restriction allow a legal or applicable routine permit vehicle in excess of the safe load carrying capacity of the bridge.

Regulatory signs shall conform to the *Indiana Manual on Uniform Traffic Control Devices* (IMUTCD). INDOT has developed additional word message signs for bridge weight limits (safe posting load). The sign details, including specific emergency vehicle signs, have been added to the INDOT Supplemental Sign Catalog and Appendix D of this document until such time as they are incorporated into the IMUTCD. The new signs have a sign code prefix of R12-Y.

Existing IMUTCD Sign R12-1 (WEIGHT LIMIT XX TONS) shall be used when the safe posting load is the same regardless of the number of axles. Each bridge shall be posted for the minimum calculated safe posting load as specified in this chapter. The R12-1 sign may be used when the safe posting load for all axles varies by no more than 2 tons, or if the bridge owner prefers to limit the gross vehicle weight regardless of the number of axles. Use of signs R12-3 (NO TRUCKS OVER XX LBS EMPTY WEIGHT) and R12-5 (WEIGHT LIMIT silhouette) is strongly discouraged as these signs are subject to misinterpretation. When the R12-5 sign is used, the tonnages listed shall correspond to the minimum calculated safe posting load for all legal and applicable routine permit vehicles for the number of axles shown. This means the sign will show a minimum tonnage for vehicles with two axles, three axles, and four or more axles.

Consider using signs R12-Y5 or sign variations R12-Y5a thru -Y5c (WEIGHT LIMIT AXLES XX WEIGHT XX) where the safe posting load varies by the number of axles. The tonnages listed shall correspond to the minimum calculated safe posting load for all legal and applicable routine permit vehicles that correspond to the number of axles shown. The number of axles may be grouped together and use the minimum safe posting load for the group.

For posting required due to emergency vehicle safe posting load, signs R12-1 with R12-Y1P (EMERGENCY VEHICLE) or signs R12-Y4-EVa thru -EVd (EMERGENCY VEHICLE ...) shall be used as appropriate based on gross weight or gross weight per number of axles. Alternatively, signs R12-Y1P (EMERGENCY VEHICLE) or signs R12-Y4-EVa thru -EVd

INDOT BRIDGE INSPECTION MANUAL

PART 3: LOAD RATING

(EMERGENCY VEHICLE ...) may be omitted provided the bridge is posted for the minimum safe posting load of all legal, applicable routine permit, and emergency vehicle loads using non-emergency vehicle specific signs shown in the IMUTCD and in Appendix D.

For bridge closures, the R11-2 sign shall be posted. Per IMUTCD Section 6F.08, “the words BRIDGE OUT (or BRIDGE CLOSED) may be substituted for ROAD (or STREET) CLOSED where applicable.” Additionally, non-movable barriers and barricades per the standard specifications shall be erected at each end of the bridge to prevent crossing by vehicles and pedestrians.

At a minimum, additional signage shall be placed at the nearest intersection prior to the bridge in all directions to allow for vehicles to turn around. On limited access highways, additional signage shall be placed prior to the nearest exit ramp to allow for overweight vehicles to exit the highway. Any other signage shall conform to the IMUTCD and used at the discretion of the roadway owner.

3-7.0 DOCUMENTATION

Examples of the required documentation are shown in Appendix C. The load rating summary report, at a minimum, shall consist of the following:

- Title sheet
- Load rating method/program(s) used
- Geometric and material summary of the bridge
- Assumptions
- Rating factors for design vehicles specified on the plans (discussed in Section 3-4.01)
 - Stamped by a Professional Engineer (PE) licensed in the state of Indiana
- Rating factors and load capacity (in tons) for each applicable legal & routine permit vehicle (discussed in Sections 3-4.02 & 3-4.03)
 - Stamped by a Professional Engineer (PE) licensed in the state of Indiana
- Safe posting load, as required, for each applicable legal & routine permit vehicle (discussed in Sections 3-4.02 & 3-4.03)
 - Stamped by a Professional Engineer (PE) licensed in the state of Indiana
- Rating factors and load capacity (in tons) for each applicable special (limited crossing) permit vehicle (discussed in Section 3-4.03)
 - Stamped by a Professional Engineer (PE) licensed in the state of Indiana
- Discussion, sketches, and photos of deterioration (if applicable)

INDOT BRIDGE INSPECTION MANUAL

PART 3: LOAD RATING

If necessary, details to load rate the bridge analytically are unavailable and engineering judgment is used per Section 3-5.02, the load rating summary report shall include the following note.

In accordance with the Manual for Bridge Evaluation, Second Edition, 2011, Section 6.1.4

- *Necessary details for this bridge are unavailable. A physical inspection of the bridge was performed by a qualified inspector and evaluated by a qualified engineer to establish an approximate load rating based on rational criteria.*

3-8.0 QUALITY CONTROL (QC) & QUALITY ASSURANCE (QA)

For a more detailed discussion of Quality Control (QC) and Quality Assurance (QA), refer to Part 2 of this manual. In short, LREs are responsible for ensuring a high degree of accuracy and consistency for any performed ratings. The Indiana Department of Transportation's load rating staff will periodically review calculations and documentation for accuracy and completeness. Rating inaccuracies or any errors or deficiencies of procedure shall be addressed immediately.

3-9.0 PROCEDURE

This chapter discusses when to perform a load rating, what to submit, and who to notify.

For new, replacement, or rehabilitated structures, Bridge Load Rating requests are required in accordance with the *Indiana Design Manual (IDM)* Chapter 103. All Bridge Load Rating requests for state owned or maintained bridges are required to be requested through the Load Rating Request Application. Any plans, sketches, notes, and photos (where applicable) are required to be uploaded to the Load Rating Request Application.

Instructions for use of the Load Rating Request Application are available from the Department's Bridge Load Rating Aids.

Load ratings for locally owned structures shall be performed by the owner or its designated appointee.

3-9.01 Frequency

INDOT BRIDGE INSPECTION MANUAL

PART 3: LOAD RATING

In general, load ratings are required whenever there is a change in condition from one inspection to another. Load ratings may also be required whenever new bridge construction projects are proposed. A description of various load rating situations is discussed in the sections below.

3-9.01(01) Project Scoping

Prior to programming bridge work, owners should consider load rating to help determine whether to rehabilitate or replace existing structures. This is particularly useful when deciding whether to use a concrete (rigid) or thin polymeric (flexible) overlay. It is also useful to determine if existing bridge rail can be replaced. There are limits to the effectiveness of load rating at this early stage. A more complicated rehabilitation (e.g. widening, replacing members, etc.) requires a set of plans to accurately model.

For state owned or maintained bridges, the District Bridge Asset Engineer (BAE) should review the structure's existing loading rating prior to programming work that adds significant dead load, e.g., a concrete overlay.

3-9.01(02) New, Replacement, or Rehabilitated Structures

Bridge owners should consider requiring a load rating be performed prior to any new, replacement, or rehabilitation work to take place on their bridge assets; this shall be done no later than the initial inspection for locally maintained structures. For state owned or maintained structures, a load rating analysis shall be performed prior to construction. See *Indiana Design Manual* Chapter 14 for specific requirements.

Following the completion of construction work, the bridge file shall be updated within thirty (30) days for state-maintained structures. To do this, a Construction Complete request using the Load Rating Request Application is required. The bridge file for locally maintained structures shall be updated within ninety (90) days.

3-9.01(03) Deterioration

For bridges with a minor increase in, or newly discovered minor damage or deterioration, a load analysis shall be performed. At a minimum, a load rating considering deterioration shall be on file

INDOT BRIDGE INSPECTION MANUAL

PART 3: LOAD RATING

for each bridge with a deck condition rating (NBIS Item 58), superstructure condition rating (NBIS Item 59), or culvert condition rating (NBIS Item 61) of 4 or less.

For state owned or maintained structures, the deterioration load rating shall be performed and documented in the bridge file within thirty (30) days of the discovery. Within seven (7) days of the discovery, the District Bridge Inspector is required to make a Condition Change – Deterioration load rating request using the Load Rating Request Application.

For locally maintained structures, the deterioration load rating shall be performed, and the bridge file shall be updated within sixty (60) days of the end of the inspection compliance month.

See Section 3-9.01(04) for requirements regarding more severe changes in condition. Additionally, if there is loss of bearing area or a substructure condition rating (NBIS Item 60) of 3 or less, consideration should be made to reducing the load rating. See Section 3-10.2 for more information regarding the modeling of deterioration.

3-9.01(04) Critical Findings

For bridges with a significant increase in or newly discovered severe damage or deterioration, a load analysis shall be performed. The analysis shall be performed within seven (7) days and the bridge file updated within fifteen (15) days of the discovery for both state and locally maintained structures. For state-maintained bridges, the District Bridge Inspector is required to make a Condition Change – Critical Finding load rating request using the Load Rating Request Application within two (2) days of discovery. Notification shall be immediate for damage or deterioration that is considered severe enough to be an immediate safety concern for the traveling public.

3-9.01(05) Repairs

Bridge owners should consider requiring a load rating to be performed prior to any repairs taking place on their bridge assets. For state-maintained structures, load rating consideration is required prior to reopening a bridge for closure situations or prior to construction for non-closure situations. Refer to the *Indiana Design Manual* for requesting a load rating for state-maintained bridges. For locally maintained structures, load ratings shall be performed no later than the initial inspection.

INDOT BRIDGE INSPECTION MANUAL

PART 3: LOAD RATING

Following the completion of construction work, the bridge file shall be updated within thirty (30) days for state-maintained structures and within ninety (90) days for locally maintained structures.

3-9.01(06) Permitting

Load ratings should be utilized when making determinations regarding the issuance of permits for overweight vehicles.

3-9.02 Submittal Process & Notification

The submittal process & notification can be broken into two categories, general and posting.

3-9.02(01) General [Rev. Apr. 2018]

For bridge construction projects, owners should be informed of load rating results prior to the commencement of any construction. For state-maintained bridges, the load rating summary report and load rating model is required to be made available for review in the Load Rating Request Application within thirty (30) days of the receipt of the original load rating request.

Once the load rating reflects the “in-service” condition of the bridge, the bridge file shall be updated. The load rating summary report, as defined in section 3-7, and the load rating model shall be uploaded to ERMS. Once uploaded, each file will be accessible in BIAS from the ERMS link on the “Asset Info” tab for each bridge; see Figure 3-9.1. Refer to the [bridge inspection website](#) for detailed instructions regarding how to attach and upload documentation. Additionally, a new report shall be created in the Bridge Rating Application Database of Indiana (BRADIN) where rating factors shall be updated.

INDOT BRIDGE INSPECTION MANUAL

PART 3: LOAD RATING

| ERMS Security Group | | | |
|--|----------------------|--|------|
| Bridge File | | | |
| Document Title | Document Date | Original File Name | Cou |
| LoadRtgSum 001-02-09885 02-15-2017.pdf | 2/15/2017 1:25:00 PM | LoadRtgSum 001-02-09885 02-15-2017.pdf | Alle |
| LoadRtgMdl 001-02-09885 02-15-2017.xml | 2/15/2017 1:25:00 PM | LoadRtgMdl 001-02-09885 02-15-2017.xml | Alle |
| LoadRtgSum 001-02-09885 02-15-2017.pdf | 2/15/2017 1:25:00 PM | LoadRtgSum 001-02-09885 02-15-2017.pdf | Alle |

Figure 3-9.1 BIAS ERMS Link to the Bridge File

3-9.02(02) Posting [Rev. Apr. 2018]

In addition to the general process in Section 3-9.02(01), the bridge owner shall immediately be notified by the LRE if load posting or any other restriction are required as discussed in Section 3-6. For state bridges, a summary of the details should be emailed to the District Bridge Asset Engineer and copied to the Bridge Director, Bridge Inspection Manager, District Bridge Inspection Engineer, System Assessment Manager, and the Technical Services Director.

Bridge owners shall have up to thirty (30) days to post all required signage and/or barriers. Once in place, the NBIS items in BRADIN shall be updated by the load rater within thirty (30) days to reflect the posting. See [the INDOT Bridge Inspection website](#) for detailed instructions. Additionally, photos should be uploaded to BIAS that show the bridge posting/closure items in place.

3-10.0 MODELING GUIDELINES & ASSUMPTIONS

This section is under development.

INDOT BRIDGE INSPECTION MANUAL

PART 3: LOAD RATING

3-11.0 APPENDICES

3-11.1 Appendix A: Vehicle Configurations

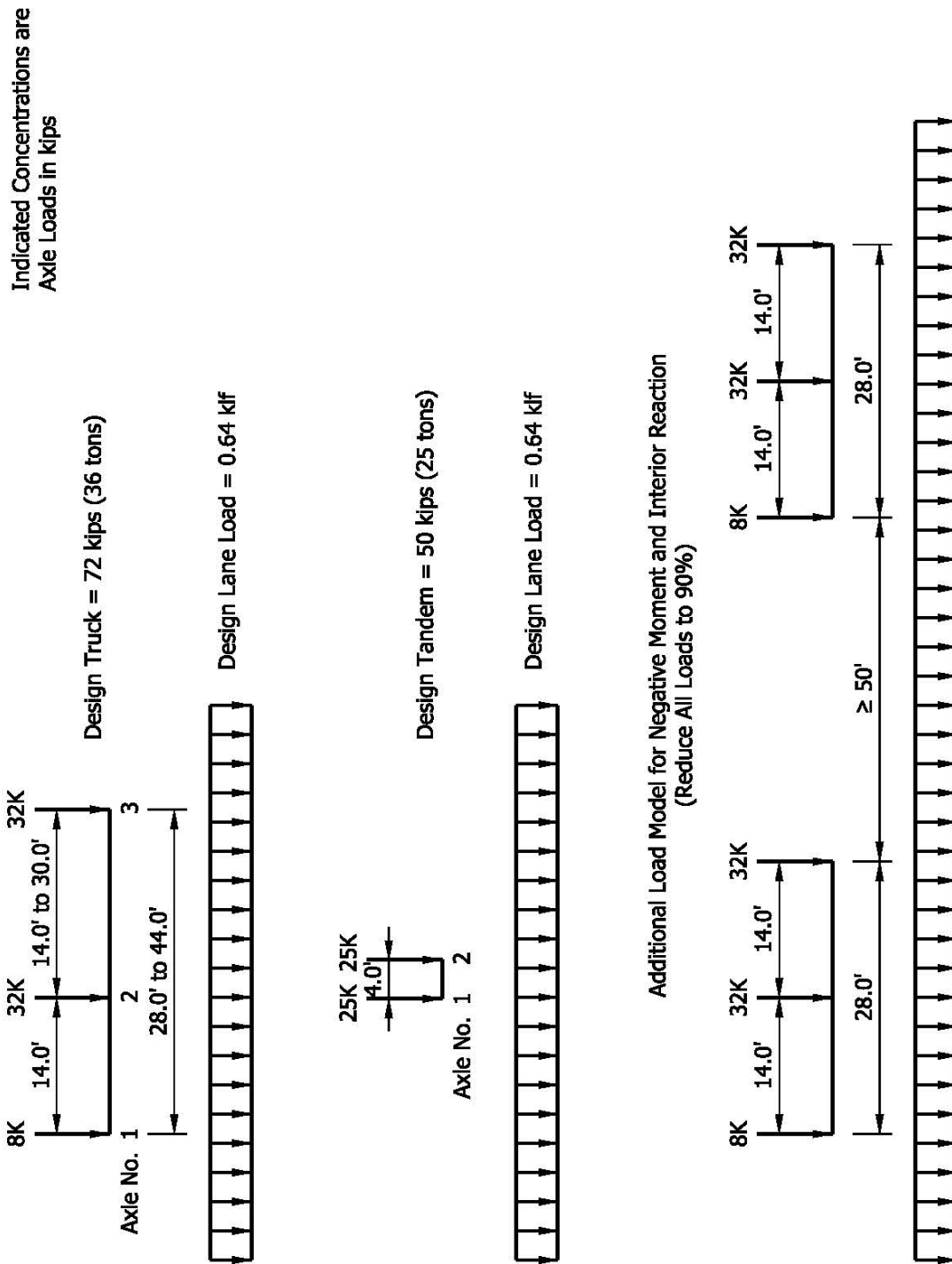
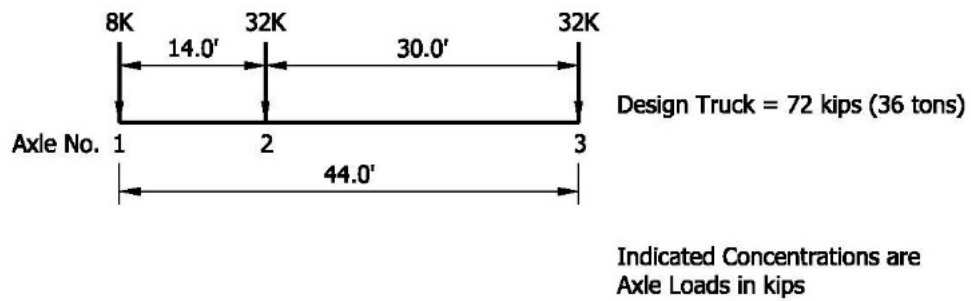

Figure A-1
HL-93 Loading

INDOT BRIDGE INSPECTION MANUAL

PART 3: LOAD RATING



**Figure A-2
Fatigue Loading**

INDOT BRIDGE INSPECTION MANUAL

PART 3: LOAD RATING

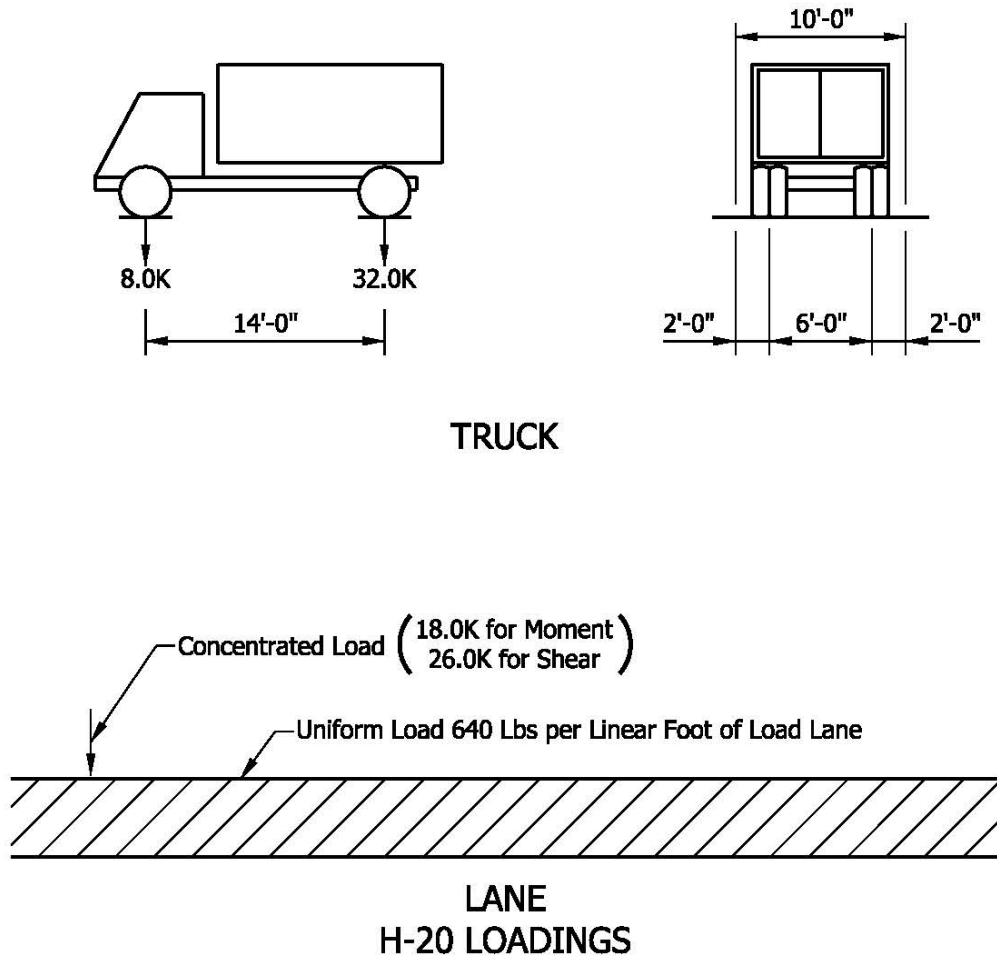

**Figure A-3
H-20 Loading**

INDOT BRIDGE INSPECTION MANUAL

PART 3: LOAD RATING

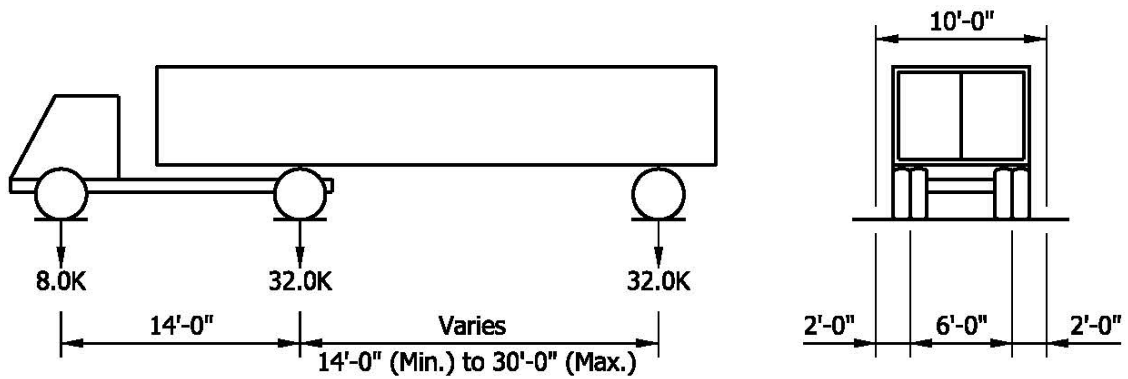

TRUCK

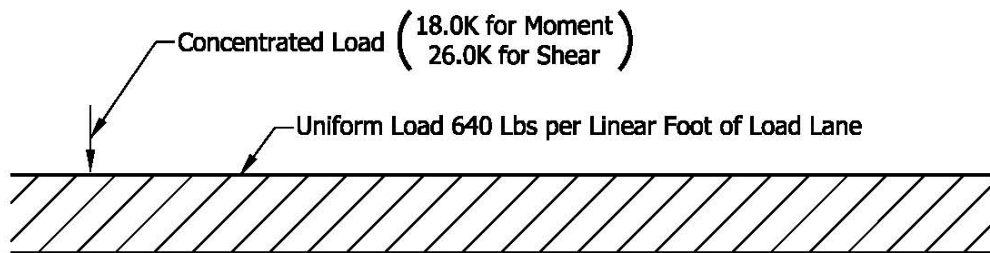

LANE
HS-20 LOADINGS

Figure A-4
HS-20 Loading

INDOT BRIDGE INSPECTION MANUAL

PART 3: LOAD RATING

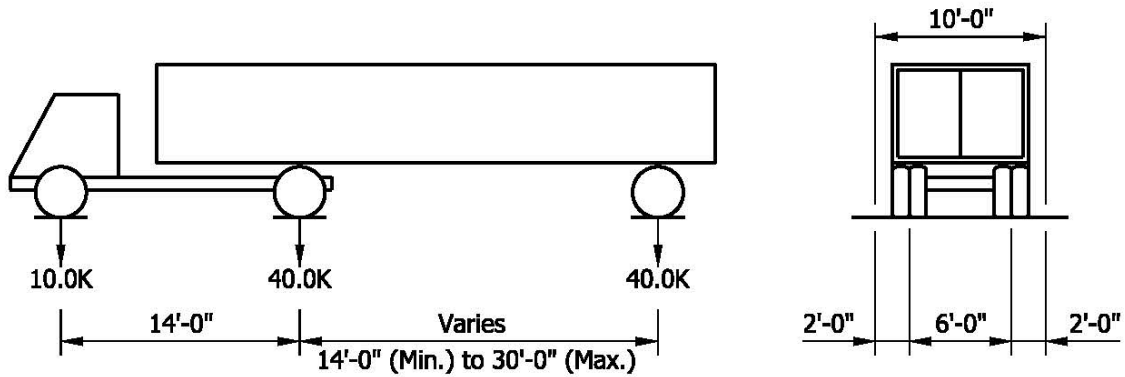

TRUCK

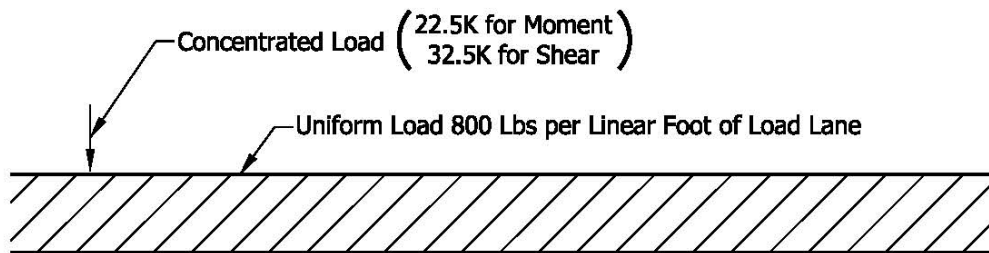

LANE
HS-25 LOADINGS

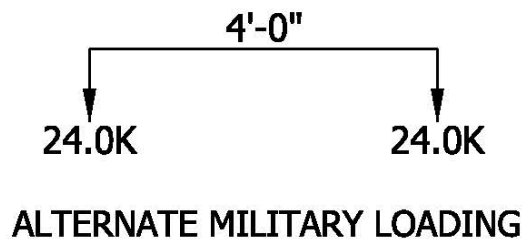

ALTERNATE MILITARY LOADING

Figure A-5
HS-25 And Alternate Military Loading

INDOT BRIDGE INSPECTION MANUAL

PART 3: LOAD RATING

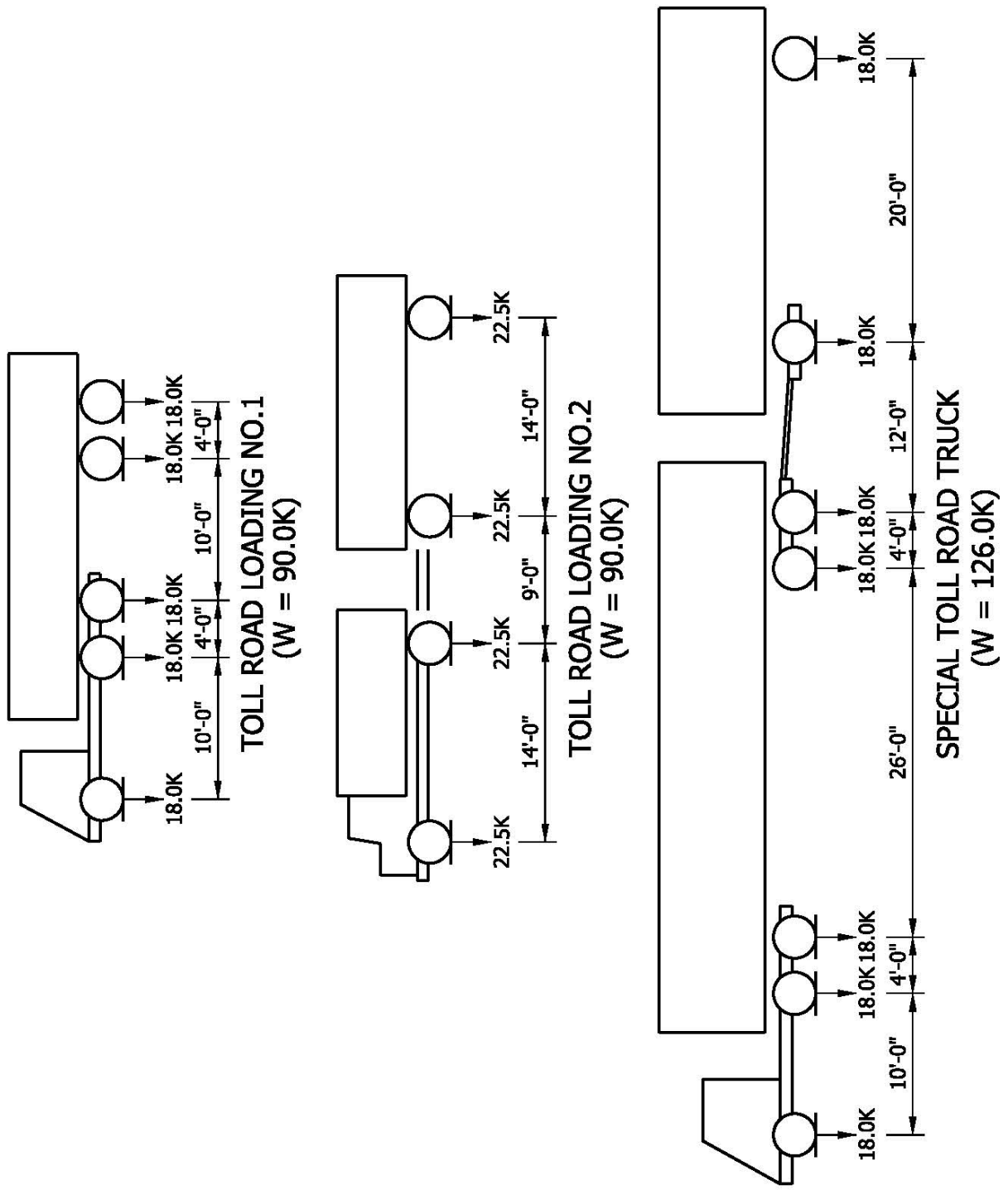

Figure A-6
Toll Road Truck Loads

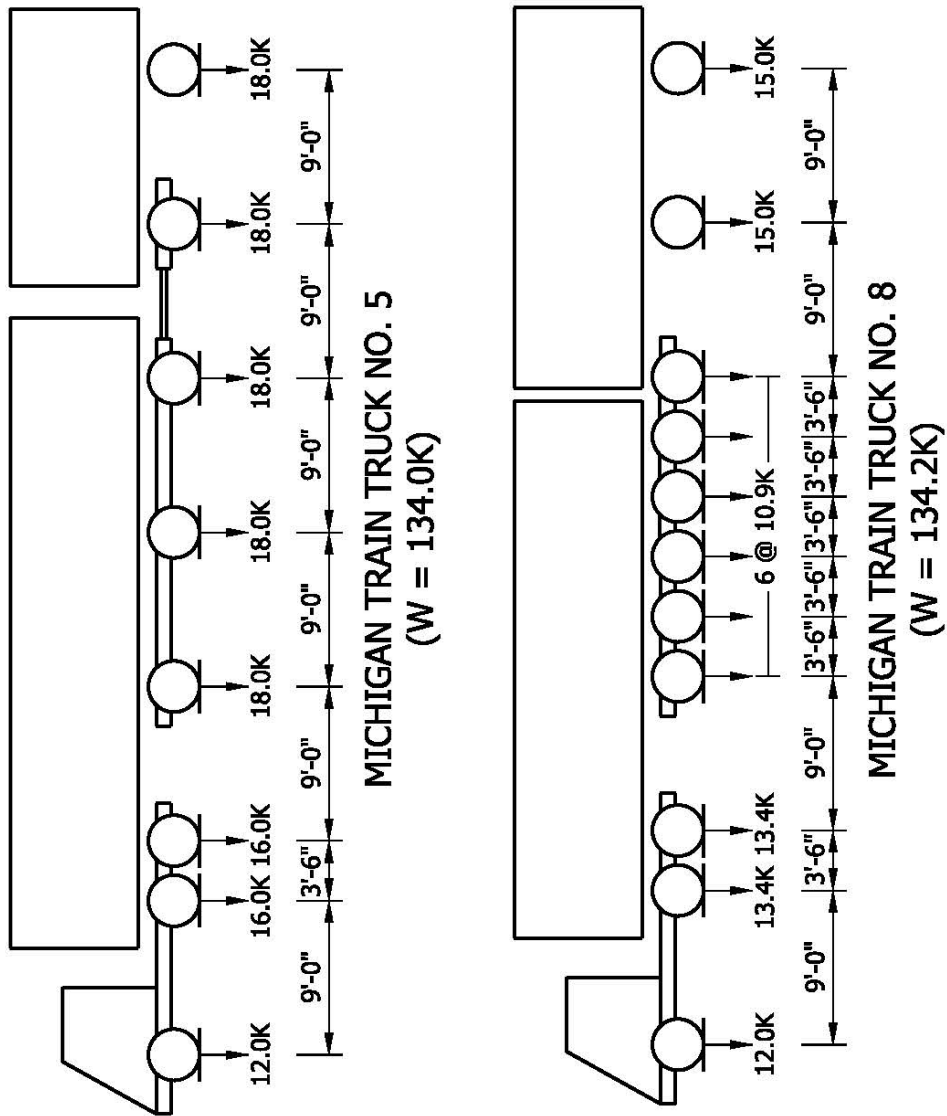
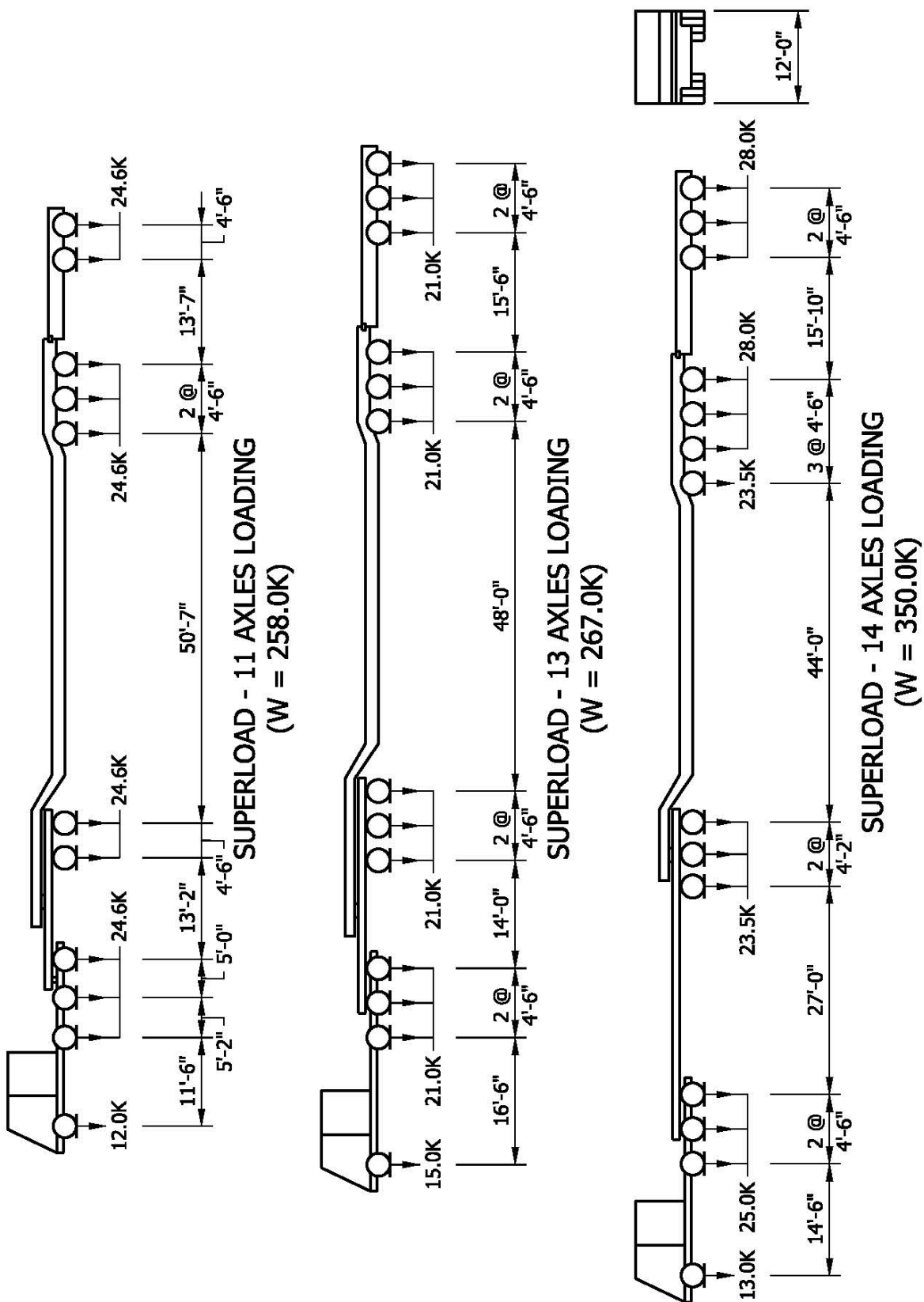
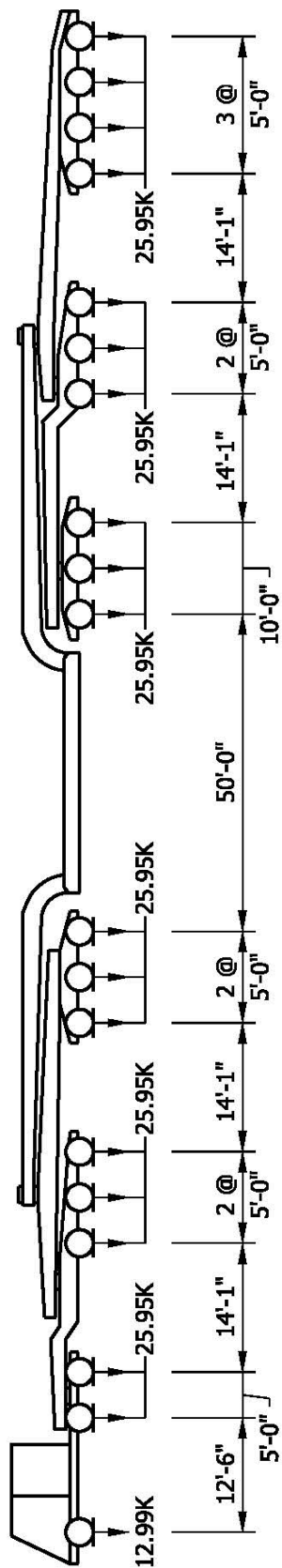
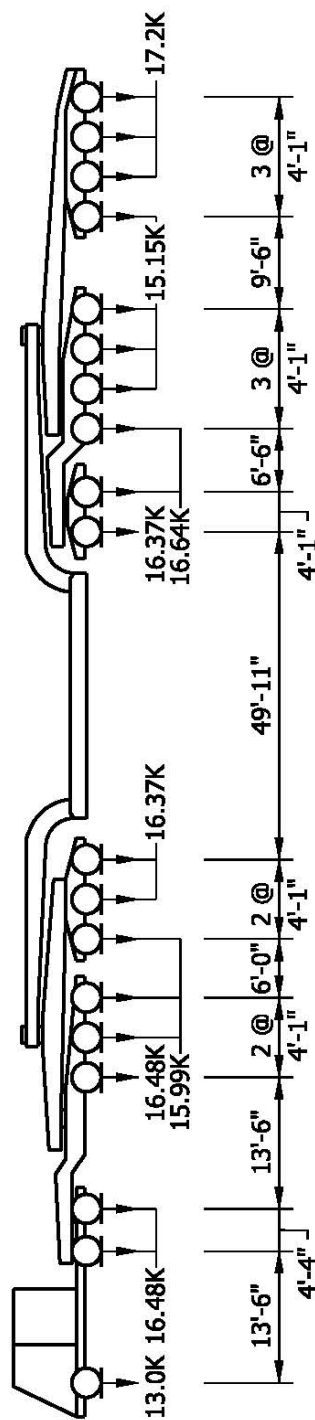

Figure A-7
Michigan Train Truck Loads





SUPERLOAD - 19 AXLES LOADING
(W = 480.09K)



SUPERLOAD - 19 AXLES LOADING
(W = 305.0K)

Figure A-9
Superload Vehicle Loads

INDOT BRIDGE INSPECTION MANUAL

PART 3: LOAD RATING

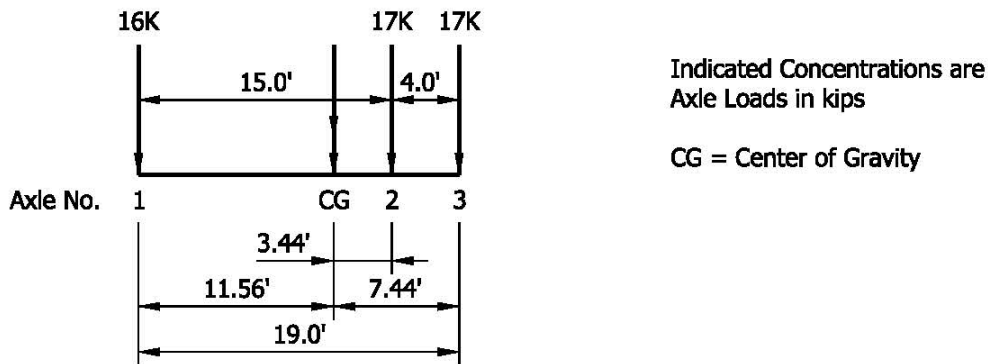

TYPE 3 UNIT
Weight = 50 kips (25 tons)

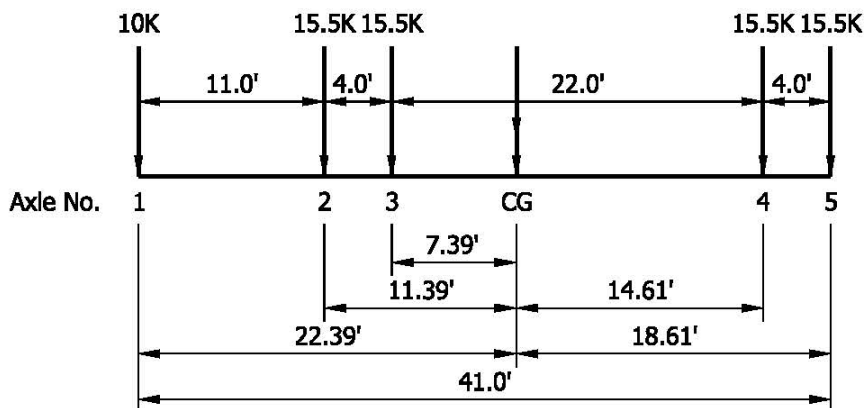

TYPE 3S2 UNIT
Weight = 72 kips (36 tons)

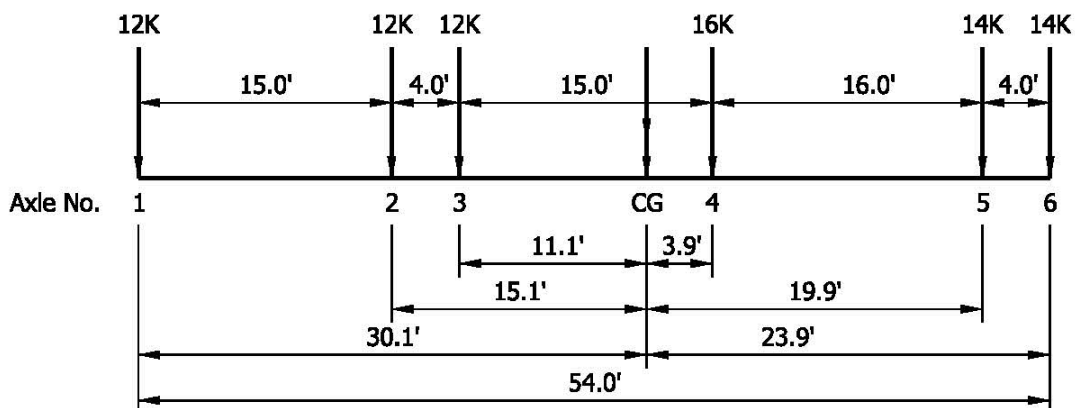

TYPE 3-3 UNIT
Weight = 80 kips (40 tons)

Figure A-10
AASHTO Legal Loads

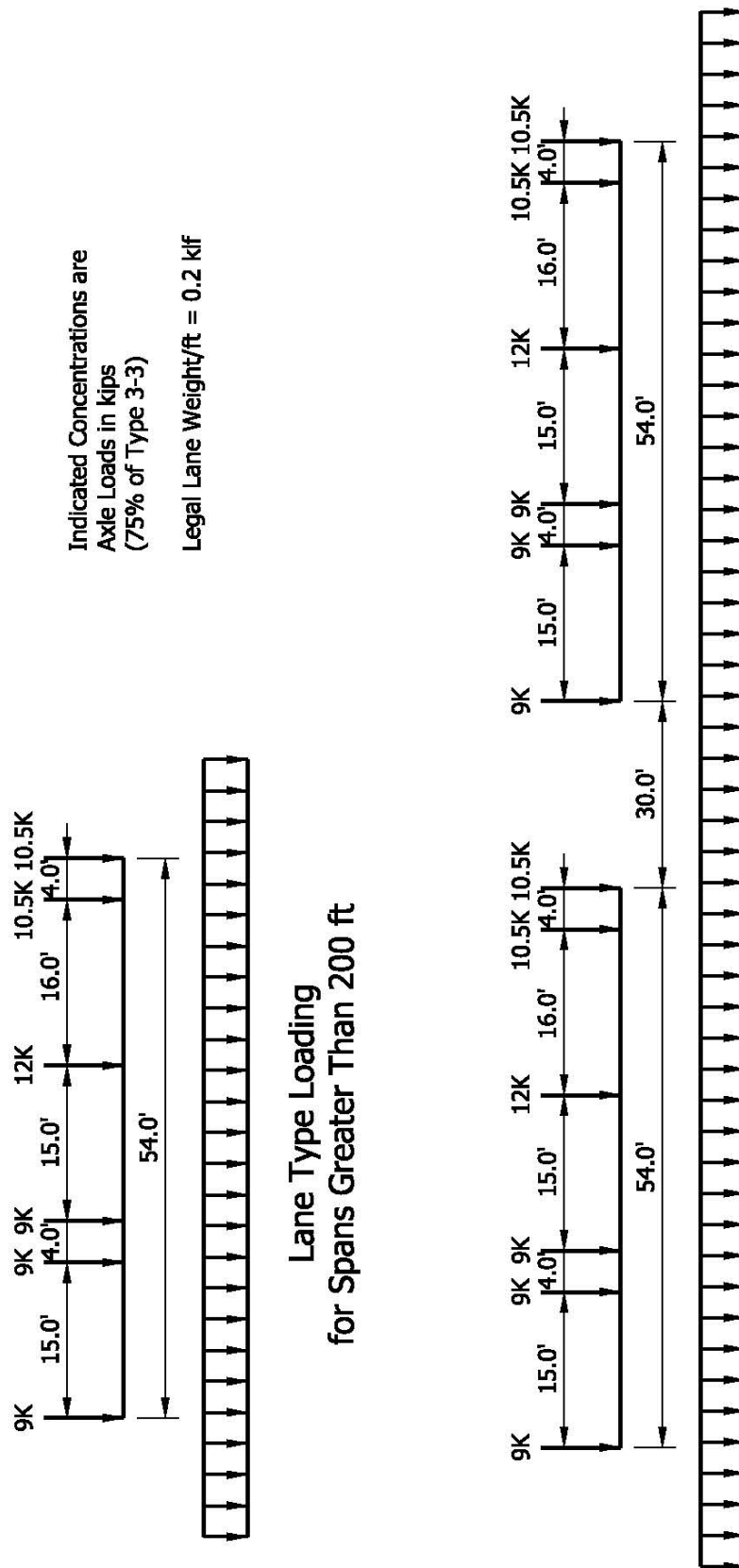
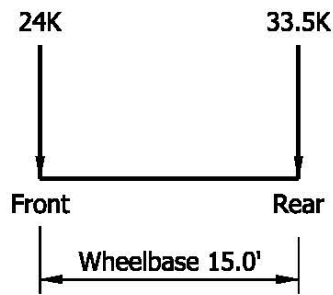

Figure A-11
Lane-Type Loading

INDOT BRIDGE INSPECTION MANUAL

PART 3: LOAD RATING



TYPE EV2

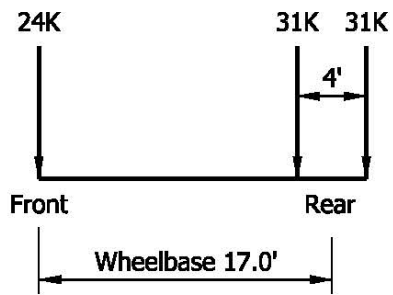

TYPE EV3

Figure A-12
FAST Act EV Loads

INDOT BRIDGE INSPECTION MANUAL

PART 3: LOAD RATING

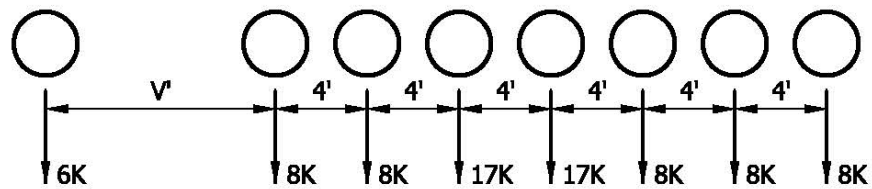

V = Variable Drive Axle Spacing - 6'-0" to 14'-0". Spacing to be used is that which produces maximum load effects.

Axes that do not contribute to the maximum load effect under consideration shall be neglected.

Maximum GVW = 80 Kips

Axle Gage Width = 6'-0"

Figure A-13
Notional Rating Load (NRL)

INDOT BRIDGE INSPECTION MANUAL

PART 3: LOAD RATING

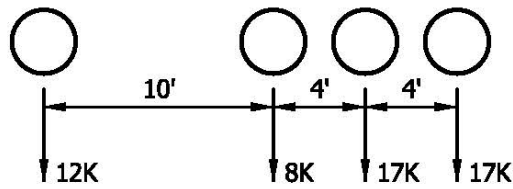

SU4 TRUCK
GW = 54 kips

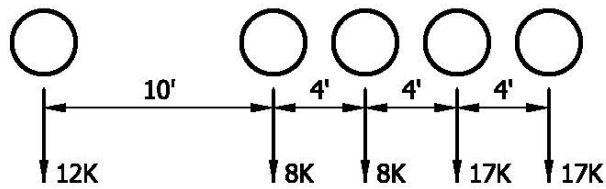

SU5 TRUCK
GW = 62 kips

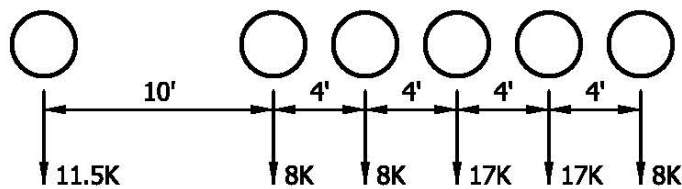

SU6 TRUCK
GW = 69.5 kips

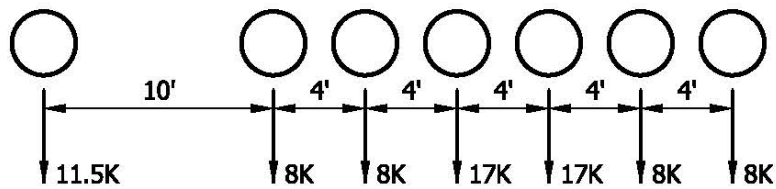

SU7 TRUCK
GW = 77.5 kips

Figure A-14
Specialized Hauling Vehicles (SHV)

INDOT BRIDGE INSPECTION MANUAL

PART 3: LOAD RATING

3-11.2 Appendix B: Extra-Heavy Duty Highways

3-11.3 Appendix C: Load Rating Report Documentation Examples [Rev. Oct. 2018]

3-11.4 Appendix D: Regulatory Sign Details [Added Apr. 2019]

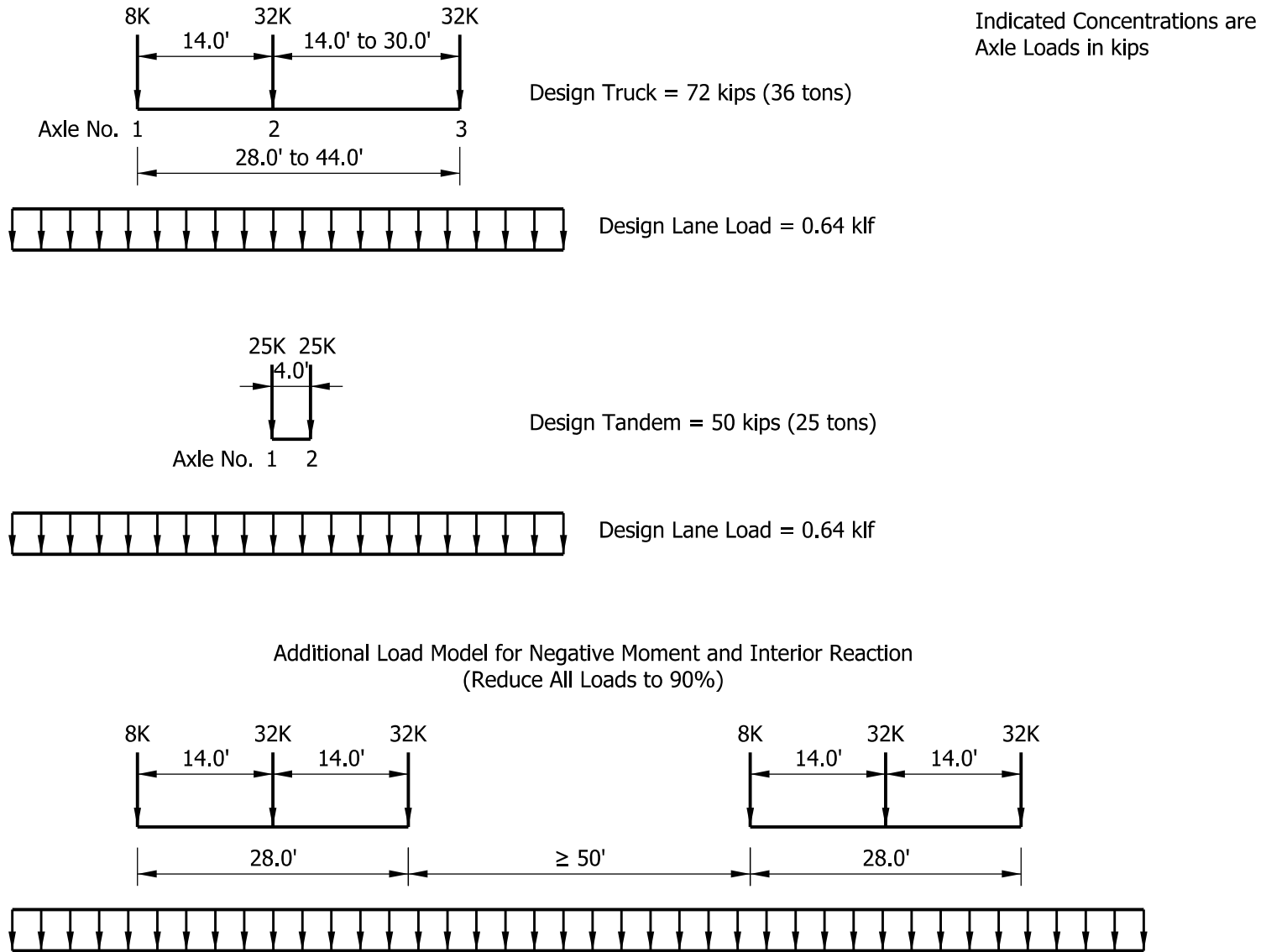

Figure A-1
HL-93 Loading

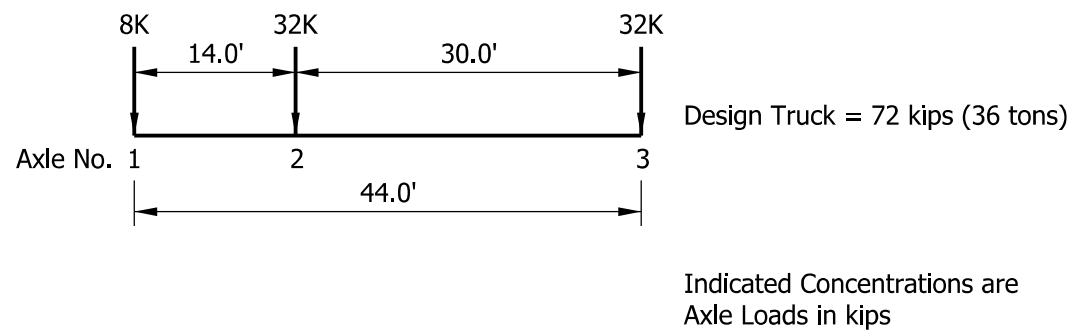
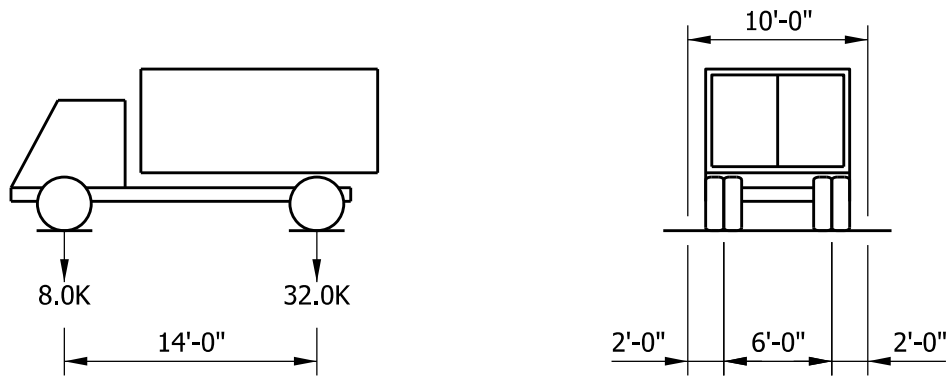
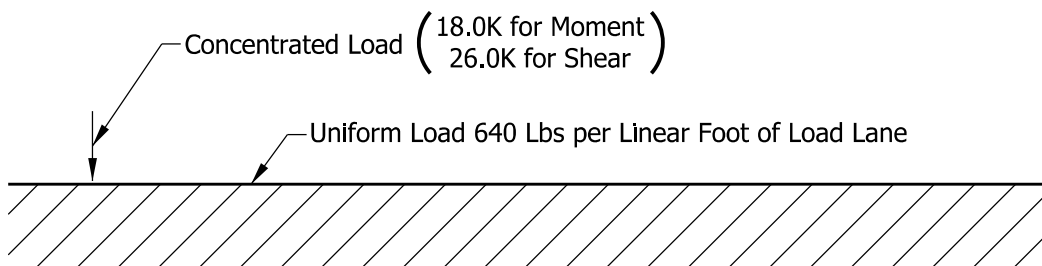

Figure A-2
Fatigue Loading



TRUCK



LANE
H-20 LOADINGS

Figure A-3
H-20 Loading

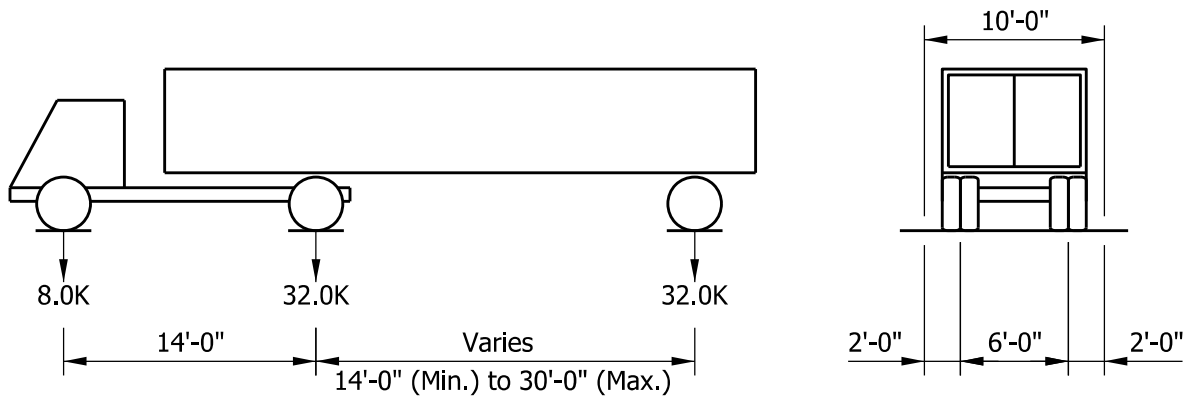

TRUCK

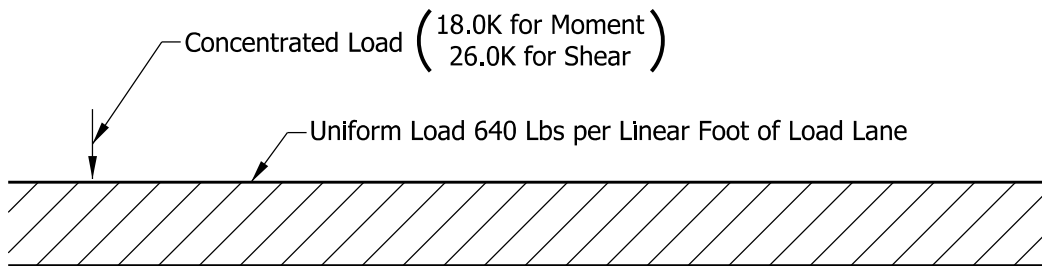

LANE
HS-20 LOADINGS

Figure A-4
HS-20 Loading

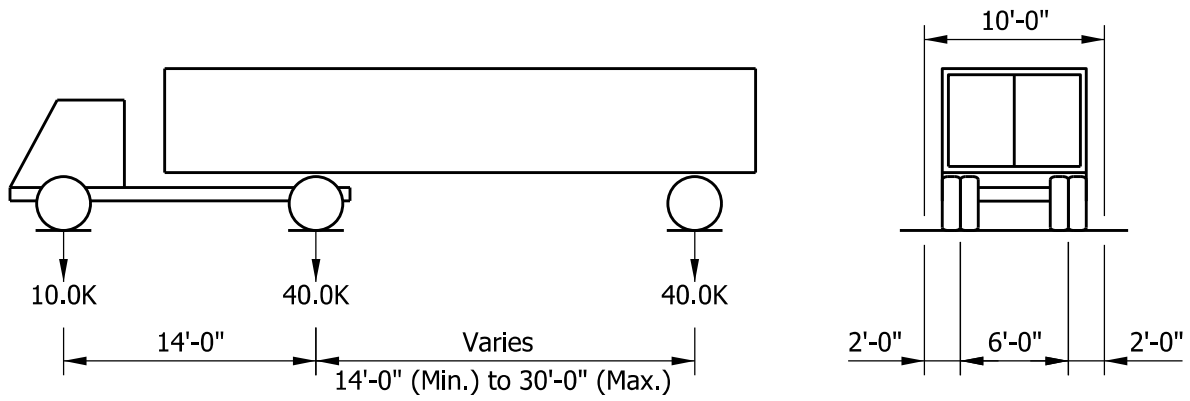

TRUCK

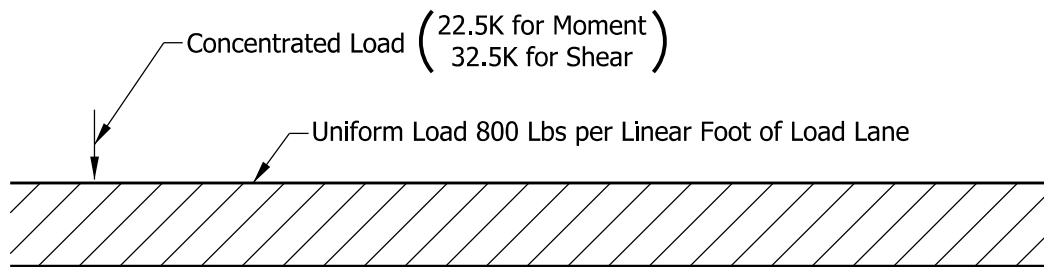

LANE
HS-25 LOADINGS

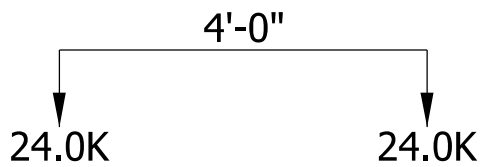

ALTERNATE MILITARY LOADING

Figure A-5
HS-25 And Alternate Military Loading

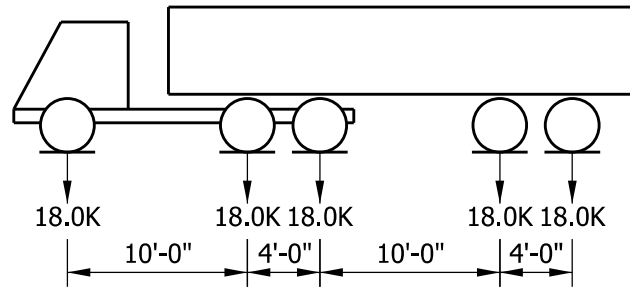

TOLL ROAD LOADING NO.1
(W = 90.0K)

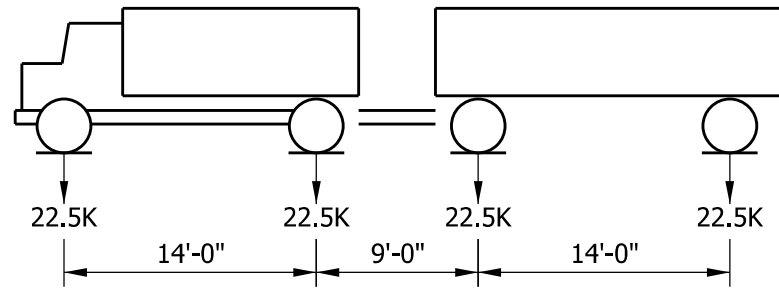

TOLL ROAD LOADING NO.2
(W = 90.0K)

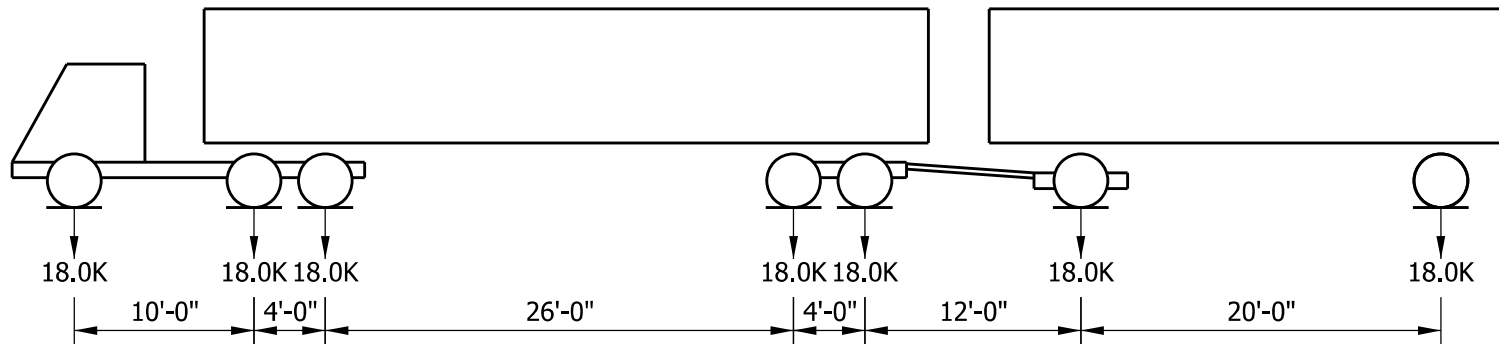

SPECIAL TOLL ROAD TRUCK
(W = 126.0K)

Figure A-6
Toll Road Truck Loads

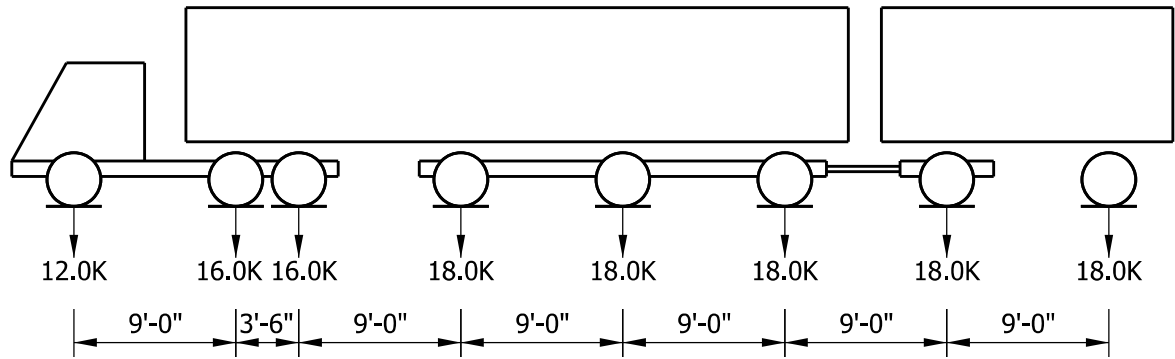

MICHIGAN TRAIN TRUCK NO. 5
(W = 134.0K)

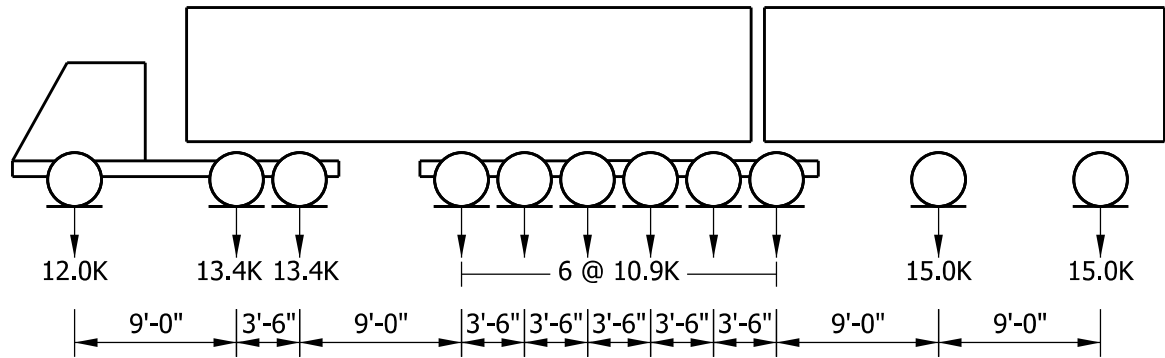

MICHIGAN TRAIN TRUCK NO. 8
(W = 134.2K)

Figure A-7
Michigan Train Truck Loads

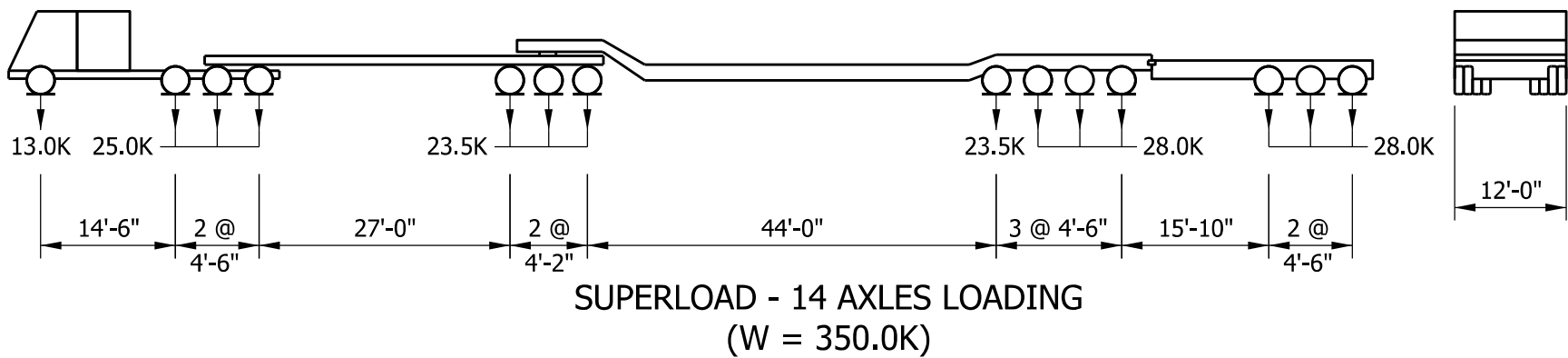
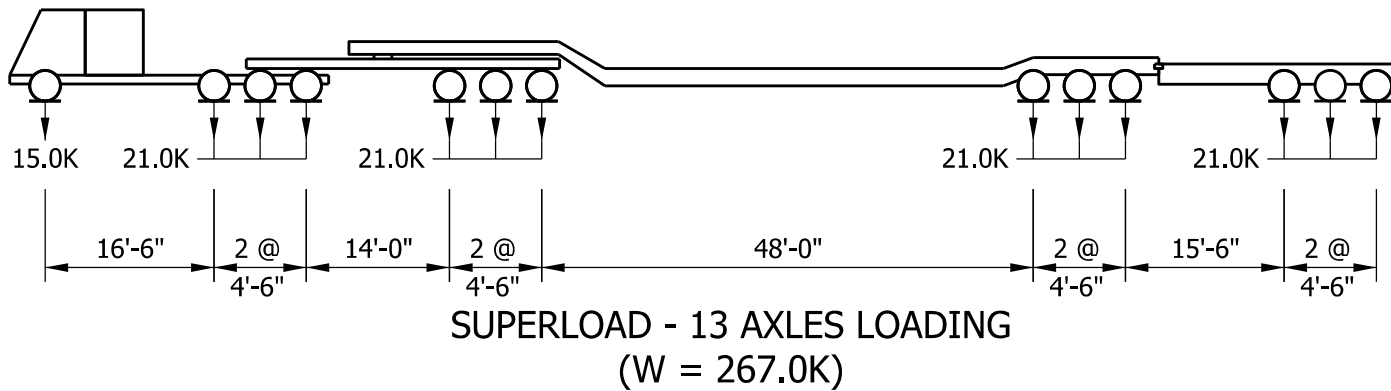
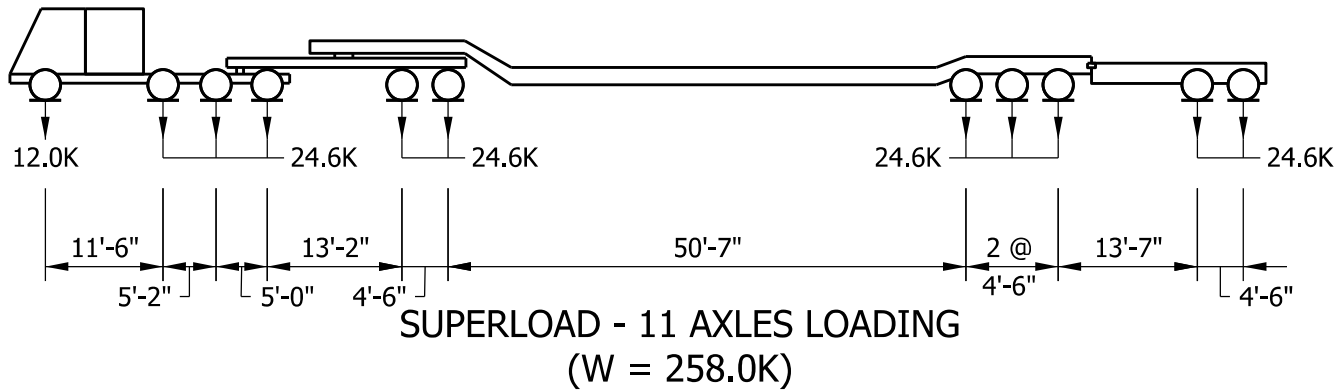

Figure A-8
Superload Vehicle Loads

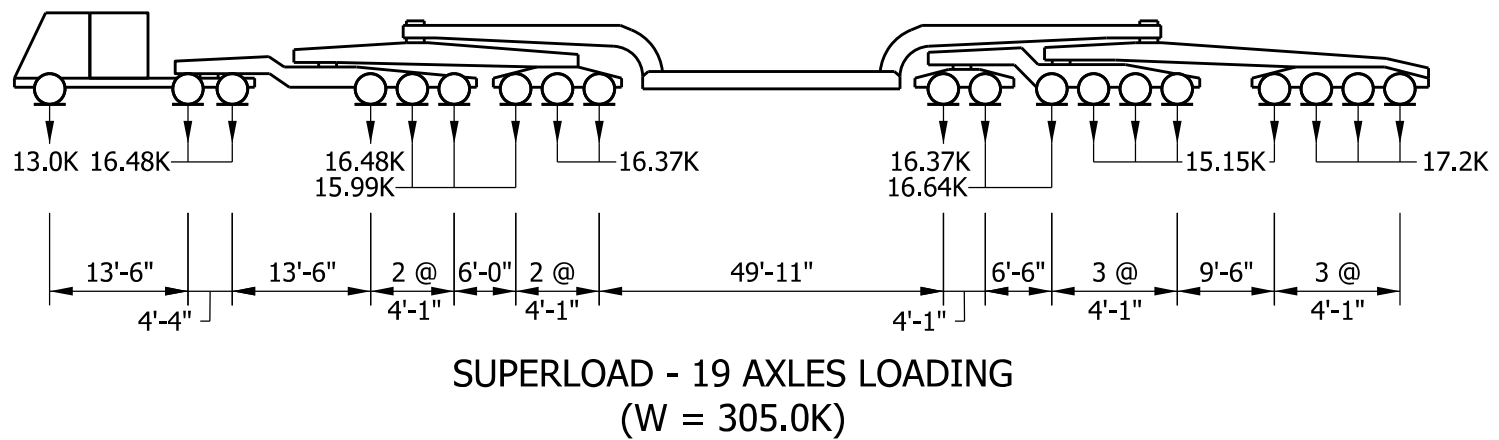
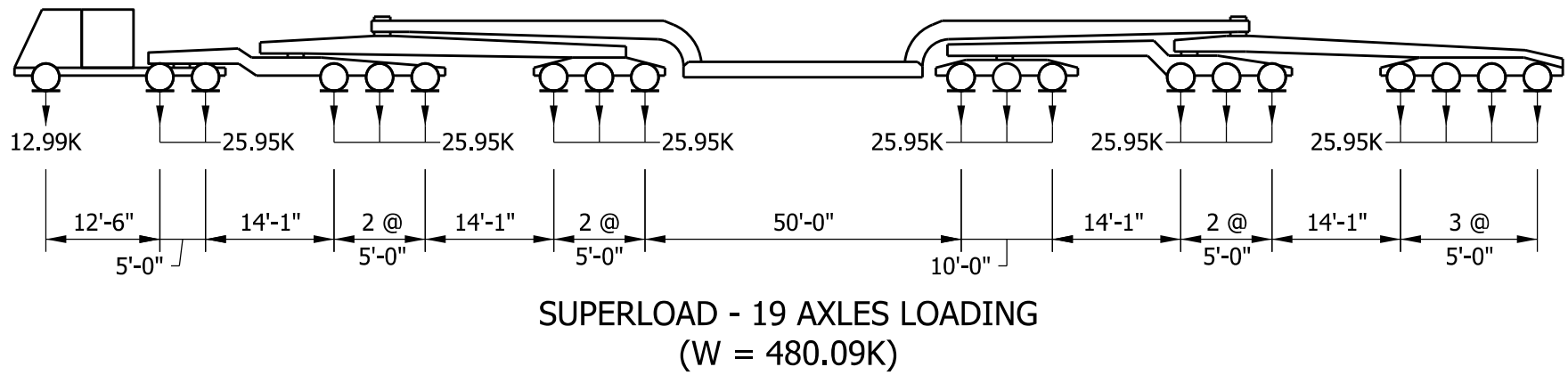
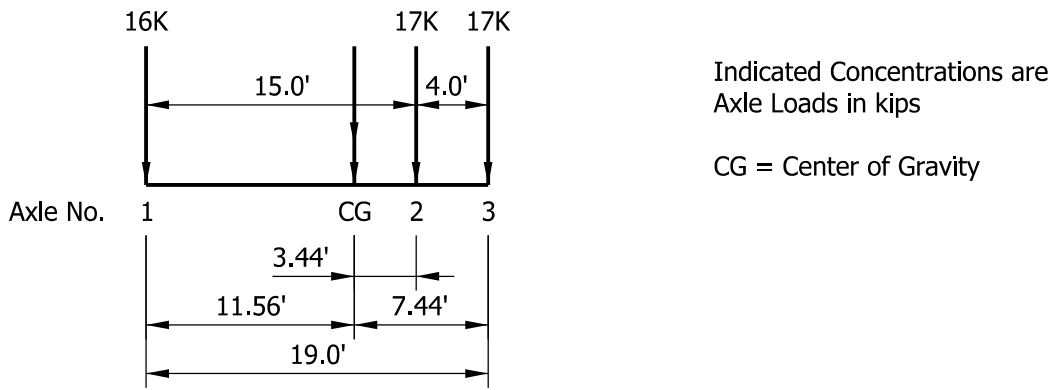
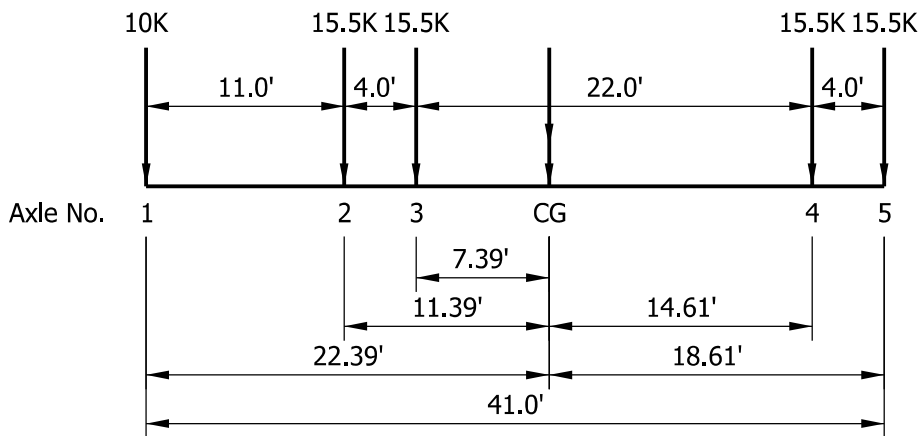

Figure A-9
Superload Vehicle Loads



TYPE 3 UNIT
 Weight = 50 kips (25 tons)



TYPE 3S2 UNIT
 Weight = 72 kips (36 tons)

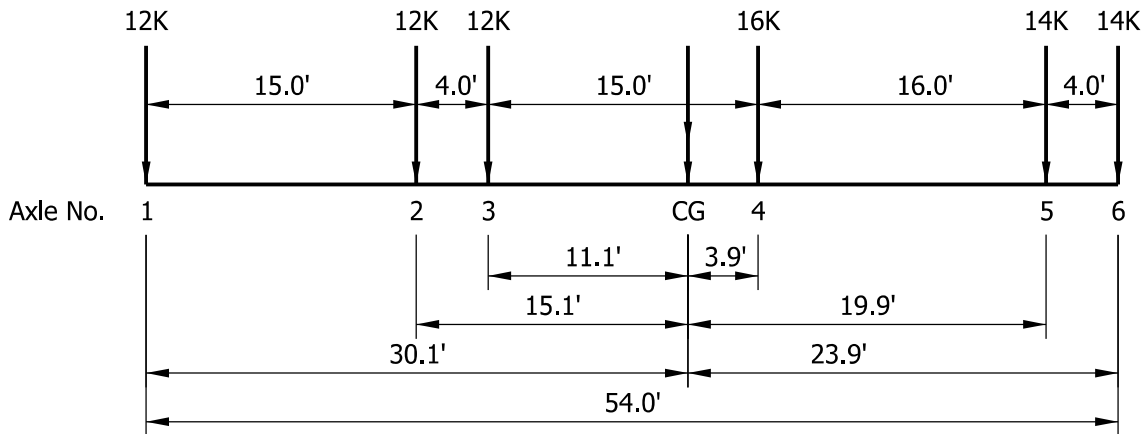

TYPE 3-3 UNIT
 Weight = 80 kips (40 tons)

Figure A-10
AASHTO Legal Loads

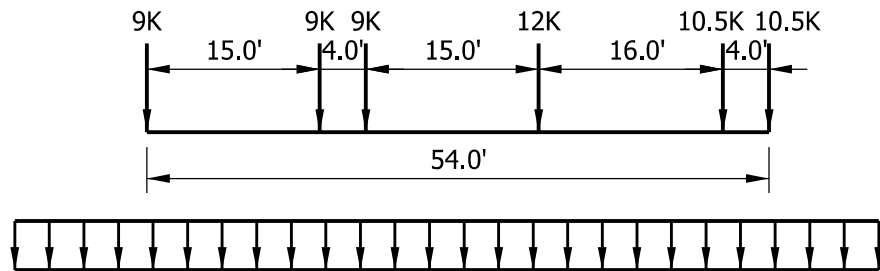

Indicated Concentrations are
Axle Loads in kips
(75% of Type 3-3)

Legal Lane Weight/ft = 0.2 klf

Lane Type Loading
for Spans Greater Than 200 ft

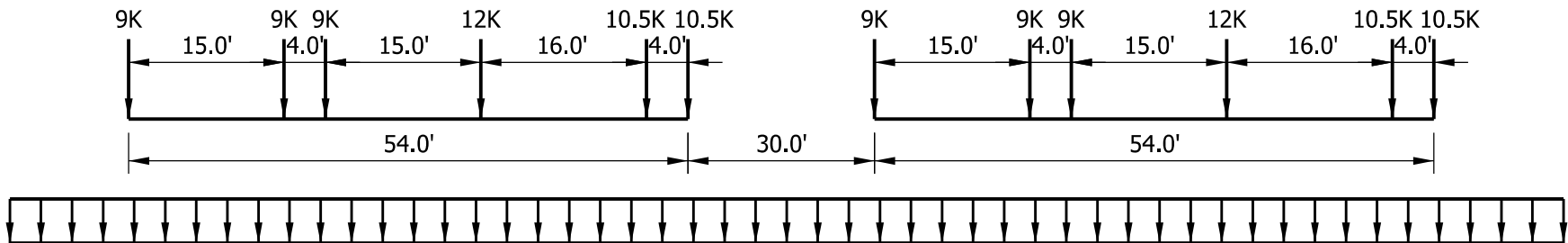

Lane Type Loading
for Negative Moment and Interior Reaction

Figure A-11
Lane-Type Loading

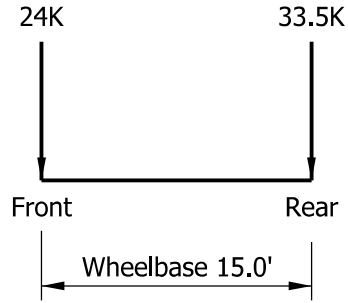

TYPE EV2

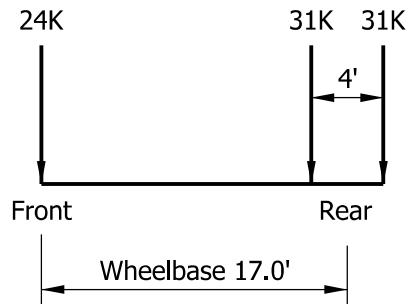

TYPE EV3

Figure A-12
FAST Act EV Loads

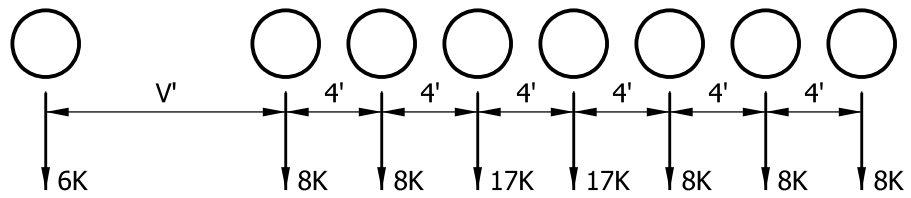

V = Variable Drive Axle Spacing - 6'-0" to 14'-0". Spacing to be used is that which produces maximum load effects.

Axles that do not contribute to the maximum load effect under consideration shall be neglected.

Maximum GVW = 80 Kips

Axle Gage Width = 6'-0"

Figure A-13
Notional Rating Load (NRL)

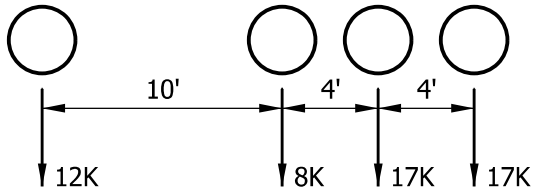

SU4 TRUCK
GVW = 54 kips

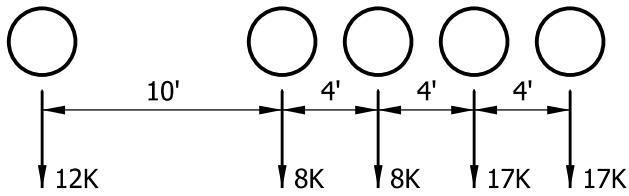

SU5 TRUCK
GVW = 62 kips

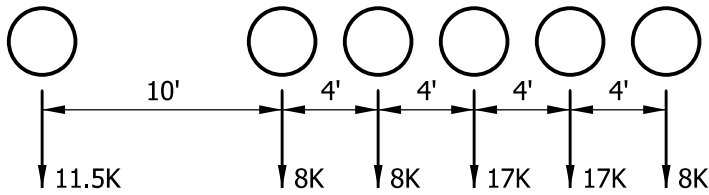

SU6 TRUCK
GVW = 69.5 kips

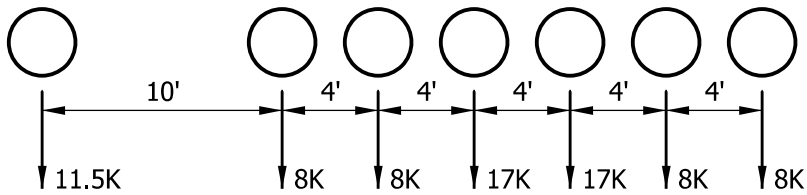

SU7 TRUCK
GVW = 77.5 kips

Figure A-14
Specialized Hauling Vehicles (SHV)

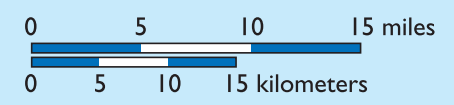

LAKE MICHIGAN

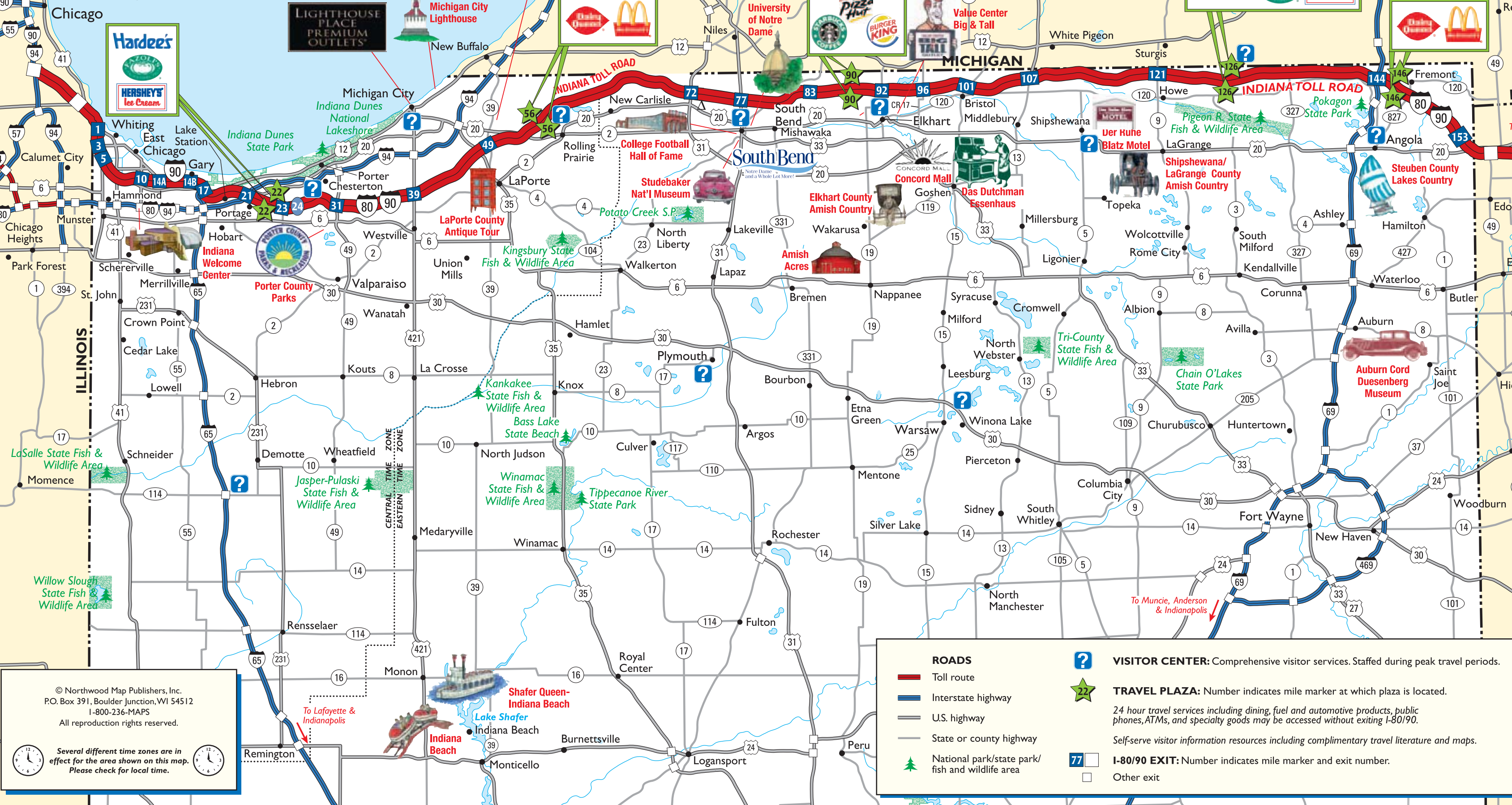

© Northwood Map Publishers, Inc.
 P.O. Box 391, Boulder Junction, WI 54512
 1-800-236-MAPS
 All reproduction rights reserved.

Several different time zones are in effect for the area shown on this map. Please check for local time.

| | |
|---|---|
| ROADS | VISITOR CENTER: Comprehensive visitor services. Staffed during peak travel periods. |
| Toll route | TRAVEL PLAZA: Number indicates mile marker at which plaza is located. 24 hour travel services including dining, fuel and automotive products, public phones, ATMs, and specialty goods may be accessed without exiting I-80/90. Self-serve visitor information resources including complimentary travel literature and maps. |
| Interstate highway | I-80/90 EXIT: Number indicates mile marker and exit number. |
| U.S. highway | Other exit |
| State or county highway | |
| National park/state park/fish and wildlife area | |



INDIANA TOLL ROAD "Main Street of the Midwest"

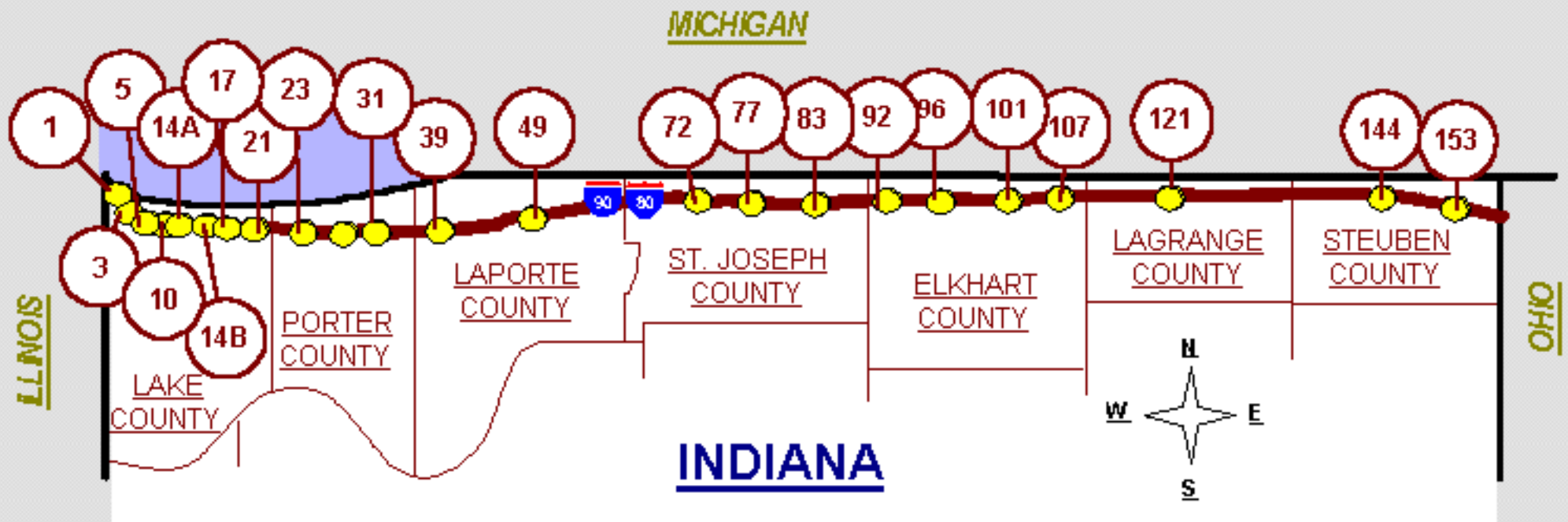

EXIT & ENTRY LOCATIONS

| <u>Mile Marker</u> | <u>Toll Plaza</u> | <u>Intersecting Routes</u> |
|--------------------|-------------------------|---|
| 1 | Westpoint Barrier | Chicago Skyway & Indianapolis Blvd. & US 41 |
| 3 | Exit 3 (Eastbound Only) | SR 912 North |
| 5 | Calumet Avenue | Calumet Avenue & US 41 |
| 10 | Cline Avenue | SR 912 South |
| 14A | Gary West | Grant & Buchanan Streets |
| 14B | Broadway | US 12 & US 20 |
| 17 | Gary East | I-65 & US 12 & US 20 |
| 21 | Lake Station | I-80/94 |
| 23 | Portage/Willow Creek | Willow Creek Road |
| 31 | Valparaiso/Chesterton | SR 49 |
| 39 | Michigan City | US 421 |
| 49 | LaPorte | SR 39 |
| 72 | South Bend West | US 31 Bypass |
| 77 | South Bend/Notre Dame | SR 933 & Business US 31 |
| 83 | Mishawaka | SR 23 |
| 92 | Elkhart | SR 19 |
| 96 | Elkhart East | CR 17 |
| 101 | Bristol/Goshen | SR 15 |
| 107 | Middlebury | SR 13 & US 131 |
| 121 | Howe/LaGrange | SR 9 |
| 144 | Angola | I-69 & US 27 & SR 127 & SR 120 |
| 153 | Eastpoint Barrier | Ohio Turnpike |

INDOT Coding Guide: *Bridge Reporting for Appraisal & Greater Inventory*

Item Number: 501.02 **Item Name:** "Heavy Duty Truck Route"

Main Tab/Sub Tab: Aux. Forms/O.V. (501) **Misc. Fields:** 501 Overall Comments

Main Tab/Sub Tab: Load Rating/Struc. Data (1) **Misc. Fields:** -

Main Tab/Sub Tab: - **Misc. Fields:** -

Main Tab/Sub Tab: - **Misc. Fields:** -

| | | | |
|---|--|--|------------------------------------|
| NBIS: <input type="checkbox"/> Yes | Toll Road: <input checked="" type="checkbox"/> Yes | Input Format: <input checked="" type="checkbox"/> Drop-Down | <input type="checkbox"/> Manual |
| INDOT: <input checked="" type="checkbox"/> Yes | County/Local: <input checked="" type="checkbox"/> Yes | X <input type="checkbox"/> Check Box | <input type="checkbox"/> Read-Only |

Description: "Heavy Duty Truck Route" (continued)

Instructions: See the detailed map below for Heavy Duty Truck Routes in Indiana, which are defined as any route carrying public vehicular traffic within a 15 mile radius of Toll Road exits.

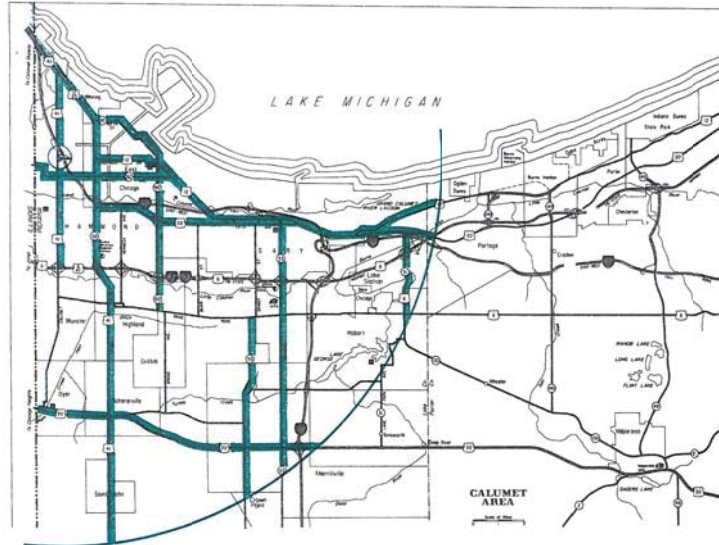

5

Exit 5

Note that the following are excluded: All Interstate Highways, Indiana Harbor Canal Lift Bridges, and SR 51 Northbound between US 20 and I-94.

Notes: -

INDOT Coding Guide: *Bridge Reporting for Appraisal & Greater Inventory*

Item Number: 501.02 **Item Name:** "Heavy Duty Truck Route"

Main Tab/Sub Tab: Aux. Forms/O.V. (501) **Misc. Fields:** 501 Overall Comments

Main Tab/Sub Tab: Load Rating/Struc. Data (1) **Misc. Fields:** -

Main Tab/Sub Tab: - **Misc. Fields:** -

Main Tab/Sub Tab: - **Misc. Fields:** -

| | | | |
|---|--|--|------------------------------------|
| NBIS: <input type="checkbox"/> Yes | Toll Road: <input checked="" type="checkbox"/> Yes | Input Format: <input checked="" type="checkbox"/> Drop-Down | <input type="checkbox"/> Manual |
| INDOT: <input checked="" type="checkbox"/> Yes | County/Local: <input checked="" type="checkbox"/> Yes | X <input type="checkbox"/> Check Box | <input type="checkbox"/> Read-Only |

Description: "Heavy Duty Truck Route" (continued)

Instructions: See the detailed map below for Heavy Duty Truck Routes in Indiana, which are defined as any route carrying public vehicular traffic within a 15 mile radius of Toll Road exits.

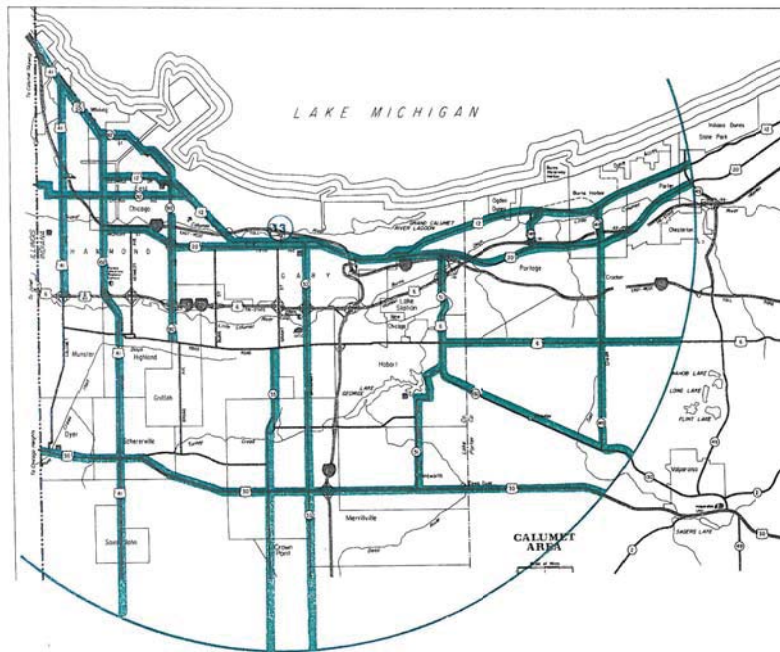

13

Exit 13

Note that the following are excluded: All Interstate Highways, Indiana Harbor Canal Lift Bridges, and SR 51 Northbound between US 20 and I-94.

Notes: -

INDOT Coding Guide: *Bridge Reporting for Appraisal & Greater Inventory*

Item Number: 501.02 **Item Name:** "Heavy Duty Truck Route"

Main Tab/Sub Tab: Aux. Forms/O.V. (501) **Misc. Fields:** 501 Overall Comments

Main Tab/Sub Tab: Load Rating/Struc. Data (1) **Misc. Fields:** -

Main Tab/Sub Tab: - **Misc. Fields:** -

Main Tab/Sub Tab: - **Misc. Fields:** -

| | | | |
|---|--|--|---|
| NBIS: <input type="checkbox"/> Yes | Toll Road: <input checked="" type="checkbox"/> Yes | Input Format: <input checked="" type="checkbox"/> Drop-Down | <input type="checkbox"/> Manual |
| INDOT: <input checked="" type="checkbox"/> Yes | County/Local: <input checked="" type="checkbox"/> Yes | X | <input type="checkbox"/> Check Box <input type="checkbox"/> Read-Only |

Description: "Heavy Duty Truck Route" (continued)

Instructions: See the detailed map below for Heavy Duty Truck Routes in Indiana, which are defined as any route carrying public vehicular traffic within a 15 mile radius of Toll Road exits.

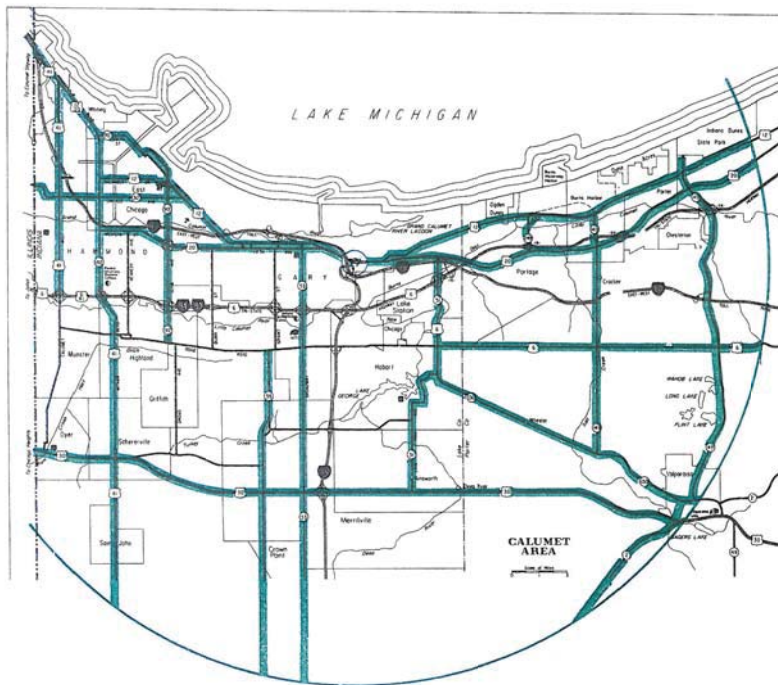

17

Exit 17

Note that the following are excluded: All Interstate Highways, Indiana Harbor Canal Lift Bridges, and SR 51 Northbound between US 20 and I-94.

Notes: -

INDOT Coding Guide: *Bridge Reporting for Appraisal & Greater Inventory*

Item Number: 501.02 **Item Name:** "Heavy Duty Truck Route"

Main Tab/Sub Tab: Aux. Forms/O.V. (501) **Misc. Fields:** 501 Overall Comments

Main Tab/Sub Tab: Load Rating/Struc. Data (1) **Misc. Fields:** -

Main Tab/Sub Tab: - **Misc. Fields:** -

Main Tab/Sub Tab: - **Misc. Fields:** -

| | | | |
|---|--|--|---|
| NBIS: <input type="checkbox"/> Yes | Toll Road: <input checked="" type="checkbox"/> Yes | Input Format: <input checked="" type="checkbox"/> Drop-Down | <input type="checkbox"/> Manual |
| INDOT: <input checked="" type="checkbox"/> Yes | County/Local: <input checked="" type="checkbox"/> Yes | X | <input type="checkbox"/> Check Box <input type="checkbox"/> Read-Only |

Description: "Heavy Duty Truck Route" (continued)

Instructions: See the detailed map below for Heavy Duty Truck Routes in Indiana, which are defined as any route carrying public vehicular traffic within a 15 mile radius of Toll Road exits.

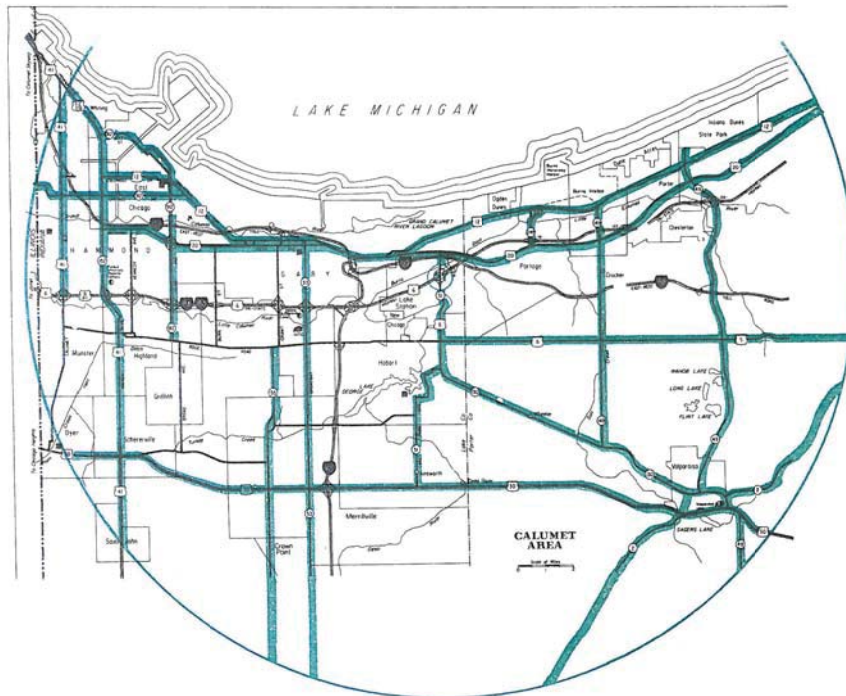

21

Exit 21

Note that the following are excluded: All Interstate Highways, Indiana Harbor Canal Lift Bridges, and SR 51 Northbound between US 20 and I-94.

Notes: -

INDOT Coding Guide: *Bridge Reporting for Appraisal & Greater Inventory*

Item Number: 501.02 **Item Name:** "Heavy Duty Truck Route"

Main Tab/Sub Tab: Aux. Forms/O.V. (501) **Misc. Fields:** 501 Overall Comments

Main Tab/Sub Tab: Load Rating/Struc. Data (1) **Misc. Fields:** -

Main Tab/Sub Tab: - **Misc. Fields:** -

Main Tab/Sub Tab: - **Misc. Fields:** -

| | | | |
|---|--|--|------------------------------------|
| NBIS: <input type="checkbox"/> Yes | Toll Road: <input checked="" type="checkbox"/> Yes | Input Format: <input checked="" type="checkbox"/> Drop-Down | <input type="checkbox"/> Manual |
| INDOT: <input checked="" type="checkbox"/> Yes | County/Local: <input checked="" type="checkbox"/> Yes | X <input type="checkbox"/> Check Box | <input type="checkbox"/> Read-Only |

Description: "Heavy Duty Truck Route" (continued)

Instructions: See the detailed map below for Heavy Duty Truck Routes in Indiana, which are defined as any route carrying public vehicular traffic within a 15 mile radius of Toll Road exits.

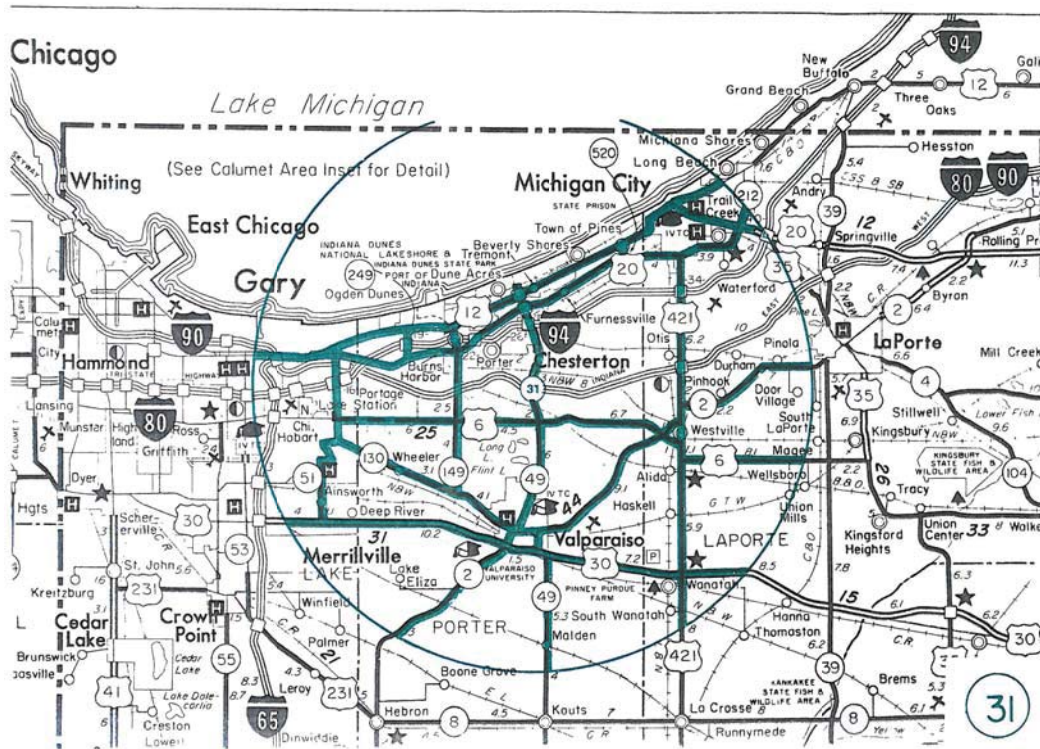

Exit 31

Note that the following are excluded: All Interstate Highways and SR 51 Northbound between US 20 and I-94.

Notes: -

INDOT Coding Guide: *Bridge Reporting for Appraisal & Greater Inventory*

Item Number: 501.02 **Item Name:** "Heavy Duty Truck Route"

Main Tab/Sub Tab: Aux. Forms/O.V. (501) **Misc. Fields:** 501 Overall Comments

Main Tab/Sub Tab: Load Rating/Struc. Data (1) **Misc. Fields:** -

Main Tab/Sub Tab: - **Misc. Fields:** -

Main Tab/Sub Tab: - **Misc. Fields:** -

NBIS: Yes **Toll Road:** Yes

Input Format: Drop-Down Manual

INDOT: Yes **County/Local:** Yes

X Check Box Read-Only

Description: "Heavy Duty Truck Route" (continued)

Instructions: See the detailed map below for Heavy Duty Truck Routes in Indiana, which are defined as any route carrying public vehicular traffic within a 15 mile radius of Toll Road exits.

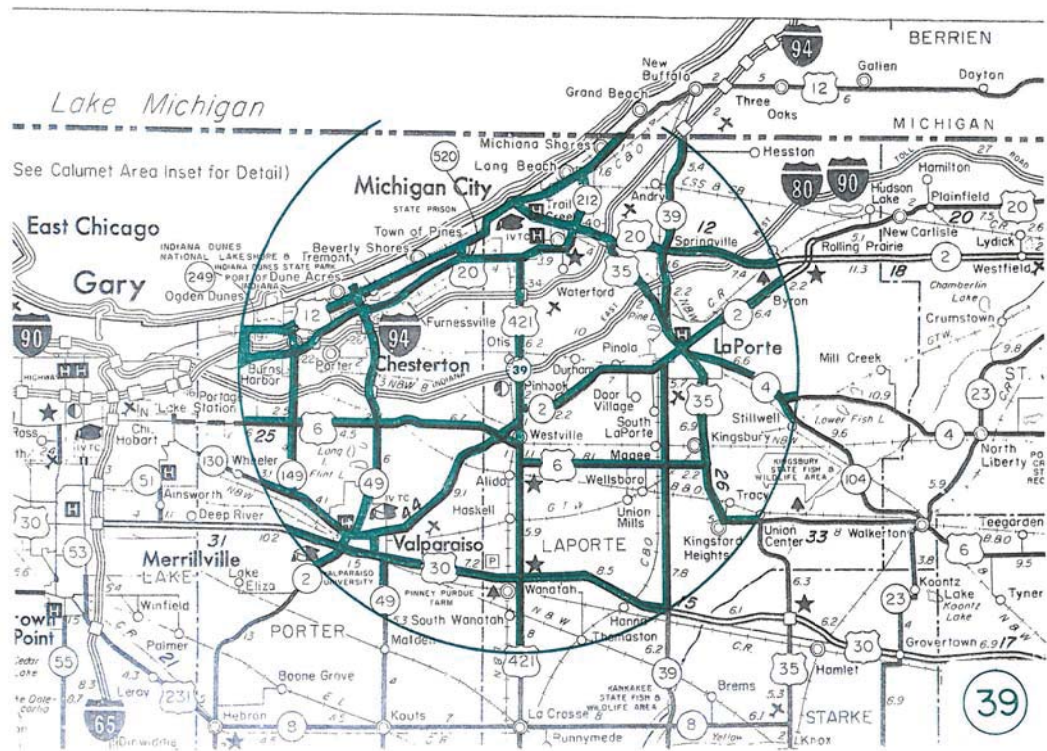

Exit 39

Note that the following are excluded: All Interstate Highways.

Notes: -

INDOT Coding Guide: *Bridge Reporting for Appraisal & Greater Inventory*

Item Number: 501.02 **Item Name:** "Heavy Duty Truck Route"

Main Tab/Sub Tab: Aux. Forms/O.V. (501) **Misc. Fields:** 501 Overall Comments

Main Tab/Sub Tab: Load Rating/Struc. Data (1) **Misc. Fields:** -

Main Tab/Sub Tab: - **Misc. Fields:** -

Main Tab/Sub Tab: - **Misc. Fields:** -

| | | | |
|---|--|--|------------------------------------|
| NBIS: <input type="checkbox"/> Yes | Toll Road: <input checked="" type="checkbox"/> Yes | Input Format: <input checked="" type="checkbox"/> Drop-Down | <input type="checkbox"/> Manual |
| INDOT: <input checked="" type="checkbox"/> Yes | County/Local: <input checked="" type="checkbox"/> Yes | X <input type="checkbox"/> Check Box | <input type="checkbox"/> Read-Only |

Description: "Heavy Duty Truck Route" (continued)

Instructions: See the detailed map below for Heavy Duty Truck Routes in Indiana, which are defined as any route carrying public vehicular traffic within a 15 mile radius of Toll Road exits.

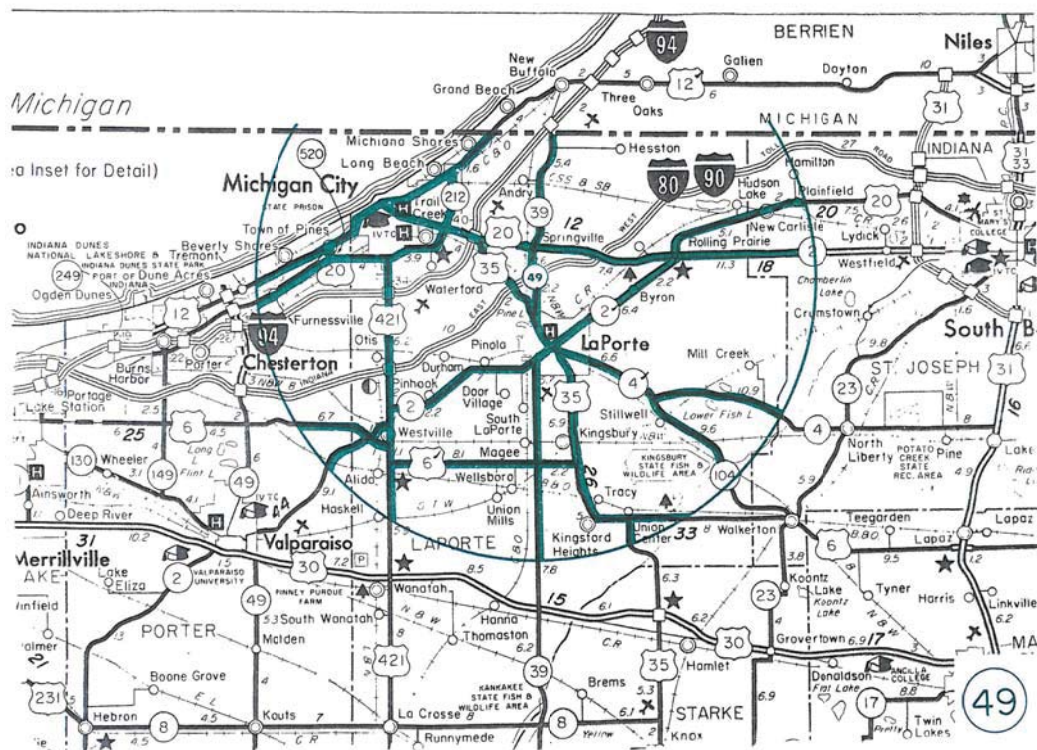

Exit 49

Note that the following are excluded: All Interstate Highways.

Notes: -

INDOT Coding Guide: *Bridge Reporting for Appraisal & Greater Inventory*

Item Number: 501.02 **Item Name:** "Heavy Duty Truck Route"

Main Tab/Sub Tab: Aux. Forms/O.V. (501) **Misc. Fields:** 501 Overall Comments

Main Tab/Sub Tab: Load Rating/Struc. Data (1) **Misc. Fields:** -

Main Tab/Sub Tab: - **Misc. Fields:** -

Main Tab/Sub Tab: - **Misc. Fields:** -

NBIS: Yes **Toll Road:** Yes

Input Format: Drop-Down Manual

INDOT: Yes **County/Local:** Yes

X Check Box Read-Only

Description: "Heavy Duty Truck Route" (continued)

Instructions: See the detailed map below for Heavy Duty Truck Routes in Indiana, which are defined as any route carrying public vehicular traffic within a 15 mile radius of Toll Road exits.

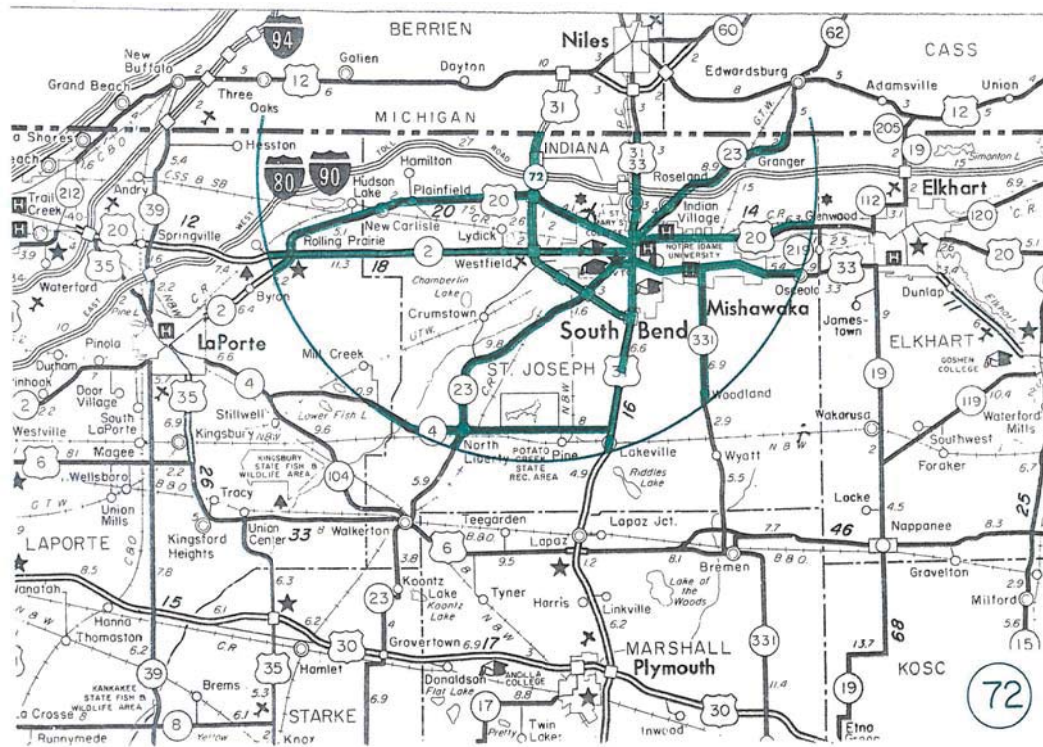

Exit 72

Note that the following are excluded: All Interstate Highways and over posted height on SR 2 between US 31 and SR 23.

Notes: -

INDOT Coding Guide: *Bridge Reporting for Appraisal & Greater Inventory*

Item Number: 501.02 **Item Name:** "Heavy Duty Truck Route"

Main Tab/Sub Tab: Aux. Forms/O.V. (501) **Misc. Fields:** 501 Overall Comments

Main Tab/Sub Tab: Load Rating/Struc. Data (1) **Misc. Fields:** -

Main Tab/Sub Tab: - **Misc. Fields:** -

Main Tab/Sub Tab: - **Misc. Fields:** -

| | | |
|---|--|--|
| NBIS: <input type="checkbox"/> Yes | Toll Road: <input checked="" type="checkbox"/> Yes | Input Format: <input checked="" type="checkbox"/> Drop-Down <input type="checkbox"/> Manual |
| INDOT: <input checked="" type="checkbox"/> Yes | County/Local: <input checked="" type="checkbox"/> Yes | X <input type="checkbox"/> Check Box <input type="checkbox"/> Read-Only |

Description: "Heavy Duty Truck Route" (continued)

Instructions: See the detailed map below for Heavy Duty Truck Routes in Indiana, which are defined as any route carrying public vehicular traffic within a 15 mile radius of Toll Road exits.

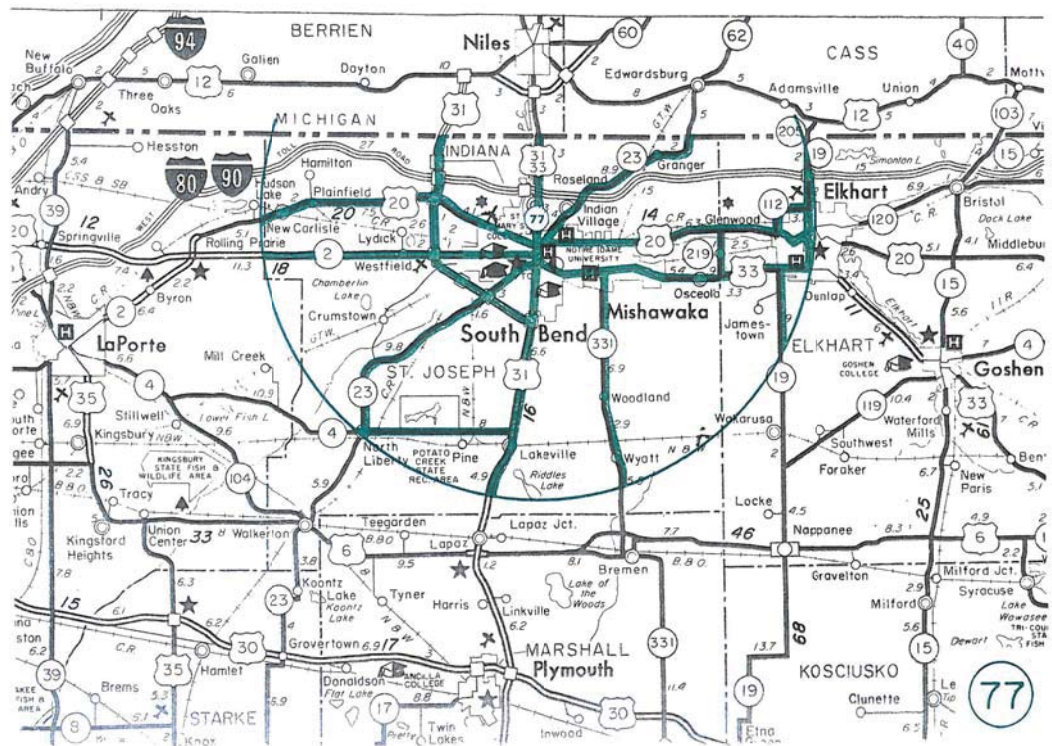

Exit 77

Note that the following are excluded: All Interstate Highways and over posted height on SR 2 between US 31 and SR 23.

Notes: -

INDOT Coding Guide: *Bridge Reporting for Appraisal & Greater Inventory*

Item Number: 501.02 **Item Name:** "Heavy Duty Truck Route"

Main Tab/Sub Tab: Aux. Forms/O.V. (501) **Misc. Fields:** 501 Overall Comments

Main Tab/Sub Tab: Load Rating/Struc. Data (1) **Misc. Fields:** -

Main Tab/Sub Tab: - **Misc. Fields:** -

Main Tab/Sub Tab: - **Misc. Fields:** -

| | | | |
|---|--|--|------------------------------------|
| NBIS: <input type="checkbox"/> Yes | Toll Road: <input checked="" type="checkbox"/> Yes | Input Format: <input checked="" type="checkbox"/> Drop-Down | <input type="checkbox"/> Manual |
| INDOT: <input checked="" type="checkbox"/> Yes | County/Local: <input checked="" type="checkbox"/> Yes | X <input type="checkbox"/> Check Box | <input type="checkbox"/> Read-Only |

Description: "Heavy Duty Truck Route" (continued)

Instructions: See the detailed map below for Heavy Duty Truck Routes in Indiana, which are defined as any route carrying public vehicular traffic within a 15 mile radius of Toll Road exits.

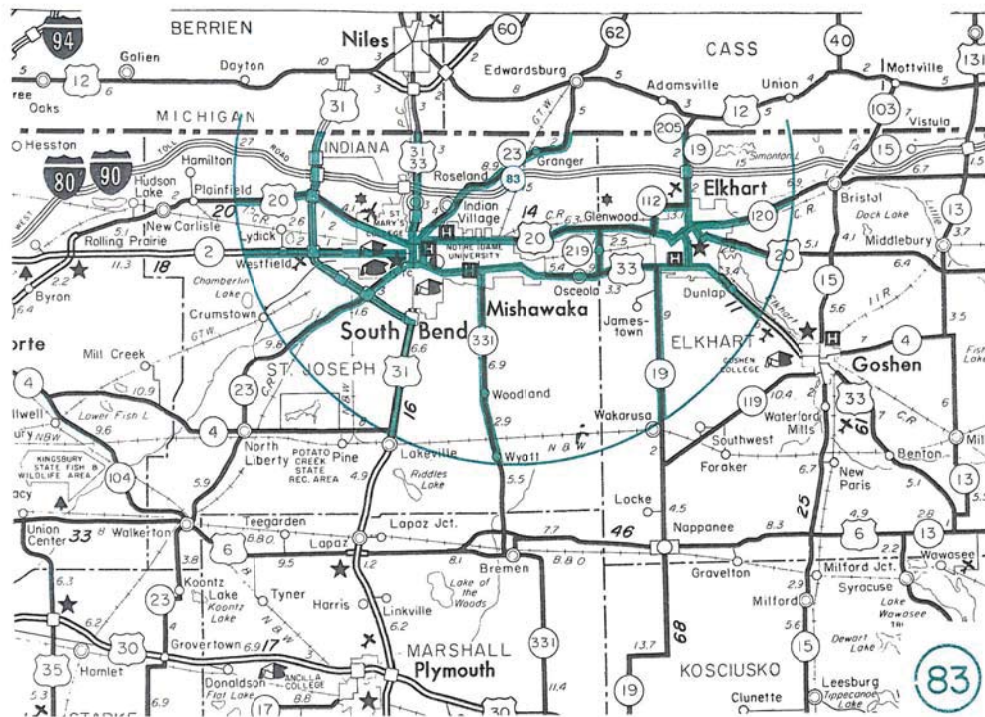

Exit 83

Note that the following are excluded: All Interstate Highways and over posted height on SR 2 between US 31 and SR 23.

Notes: -

INDOT Coding Guide: *Bridge Reporting for Appraisal & Greater Inventory*

Item Number: 501.02 **Item Name:** "Heavy Duty Truck Route"

Main Tab/Sub Tab: Aux. Forms/O.V. (501) **Misc. Fields:** 501 Overall Comments

Main Tab/Sub Tab: Load Rating/Struc. Data (1) **Misc. Fields:** -

Main Tab/Sub Tab: - **Misc. Fields:** -

Main Tab/Sub Tab: - **Misc. Fields:** -

| | | | |
|---|--|--|------------------------------------|
| NBIS: <input type="checkbox"/> Yes | Toll Road: <input checked="" type="checkbox"/> Yes | Input Format: <input checked="" type="checkbox"/> Drop-Down | <input type="checkbox"/> Manual |
| INDOT: <input checked="" type="checkbox"/> Yes | County/Local: <input checked="" type="checkbox"/> Yes | X <input type="checkbox"/> Check Box | <input type="checkbox"/> Read-Only |

Description: "Heavy Duty Truck Route" (continued)

Instructions: See the detailed map below for Heavy Duty Truck Routes in Indiana, which are defined as any route carrying public vehicular traffic within a 15 mile radius of Toll Road exits.

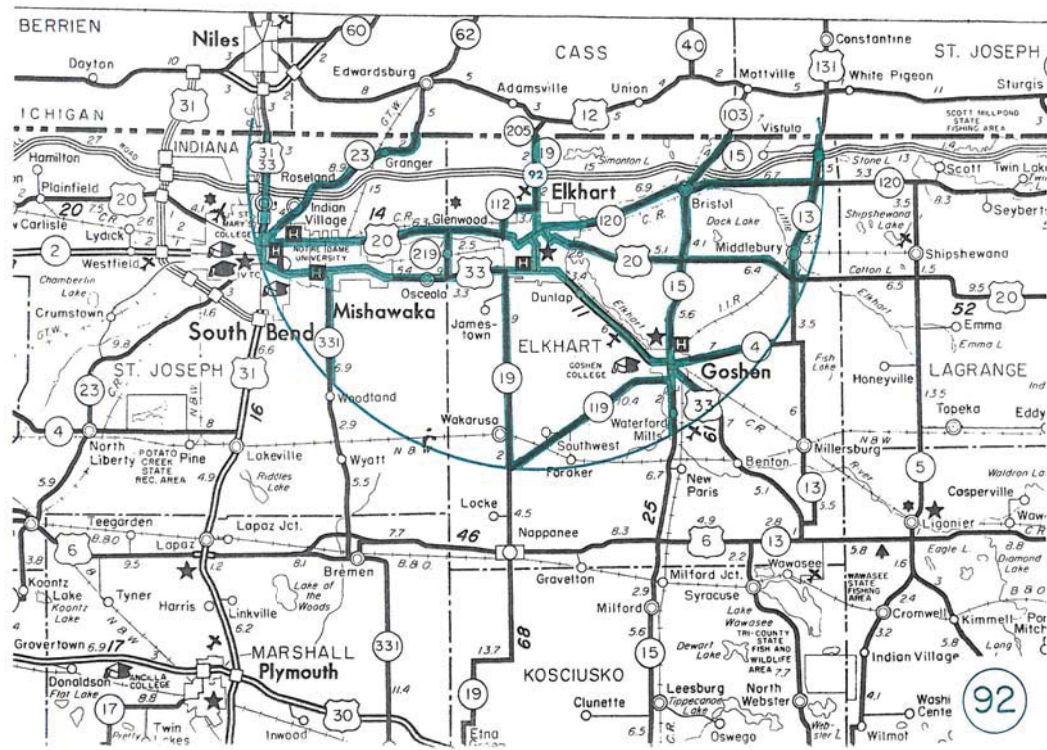

Exit 92

Note that the following are excluded: All Interstate Highways.

Notes: -

INDOT Coding Guide: *Bridge Reporting for Appraisal & Greater Inventory*

Item Number: 501.02 **Item Name:** "Heavy Duty Truck Route"

Main Tab/Sub Tab: Aux. Forms/O.V. (501) **Misc. Fields:** 501 Overall Comments

Main Tab/Sub Tab: Load Rating/Struc. Data (1) **Misc. Fields:** -

Main Tab/Sub Tab: - **Misc. Fields:** -

Main Tab/Sub Tab: - **Misc. Fields:** -

NBIS: Yes **Toll Road:** Yes **Input Format:** Drop-Down Manual

INDOT: Yes **County/Local:** Yes **X** Check Box Read-Only

Description: "Heavy Duty Truck Route" (continued)

Instructions: See the detailed map below for Heavy Duty Truck Routes in Indiana, which are defined as any route carrying public vehicular traffic within a 15 mile radius of Toll Road exits.

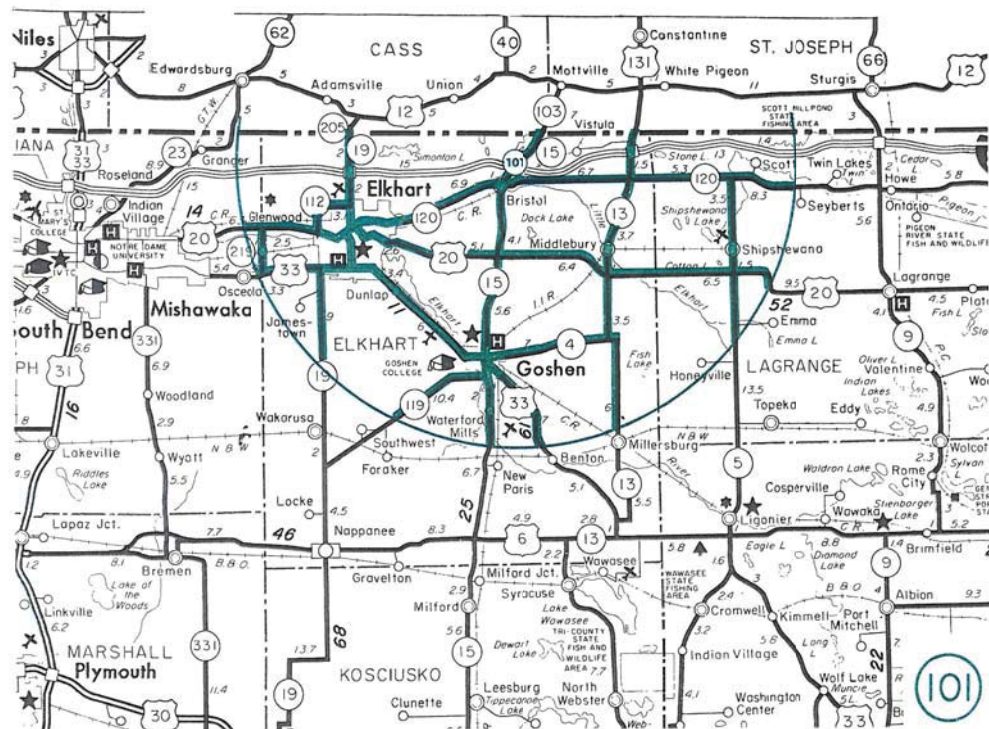

Exit 101

Note that the following are excluded: All Interstate Highways and any vehicles with an overall length in excess of 95 feet.

Notes: -

INDOT Coding Guide: *Bridge Reporting for Appraisal & Greater Inventory*

Item Number: 501.02 **Item Name:** "Heavy Duty Truck Route"

Main Tab/Sub Tab: Aux. Forms/O.V. (501) **Misc. Fields:** 501 Overall Comments

Main Tab/Sub Tab: Load Rating/Struc. Data (1) **Misc. Fields:** -

Main Tab/Sub Tab: - **Misc. Fields:** -

Main Tab/Sub Tab: - **Misc. Fields:** -

NBIS: Yes **Toll Road:** Yes

Input Format: Drop-Down Manual

INDOT: Yes **County/Local:** Yes

X Check Box Read-Only

Description: "Heavy Duty Truck Route" (continued)

Instructions: See the detailed map below for Heavy Duty Truck Routes in Indiana, which are defined as any route carrying public vehicular traffic within a 15 mile radius of Toll Road exits.

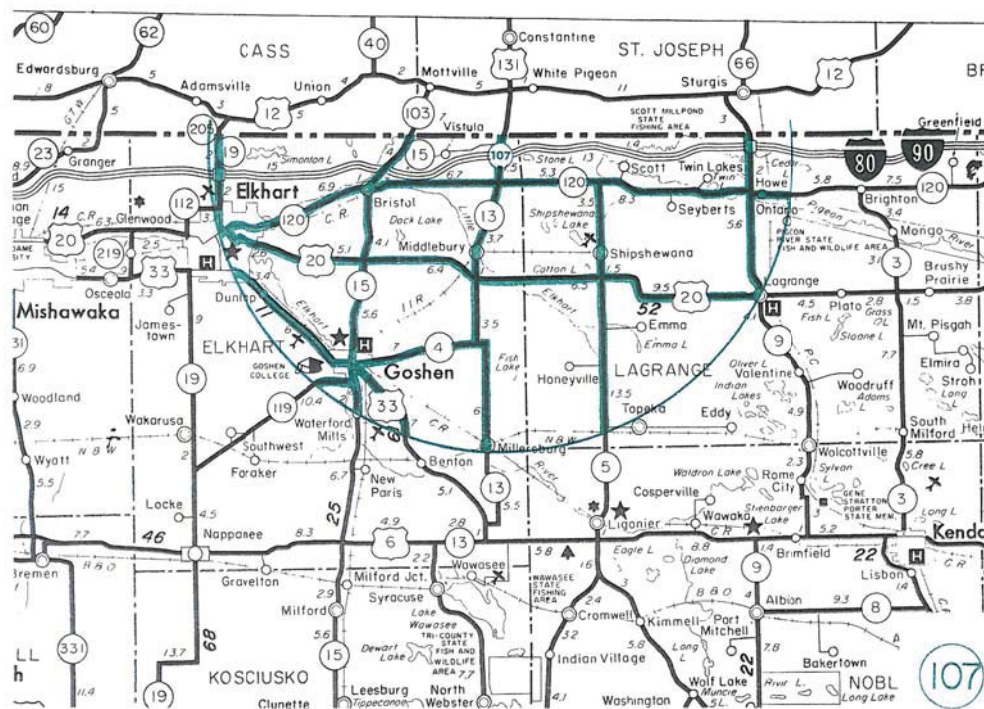

Exit 107

Note that the following are excluded: All Interstate Highways.

Notes: -

INDOT Coding Guide: *Bridge Reporting for Appraisal & Greater Inventory*

Item Number: 501.02 **Item Name:** "Heavy Duty Truck Route"

Main Tab/Sub Tab: Aux. Forms/O.V. (501) **Misc. Fields:** 501 Overall Comments

Main Tab/Sub Tab: Load Rating/Struc. Data (1) **Misc. Fields:** -

Main Tab/Sub Tab: - **Misc. Fields:** -

Main Tab/Sub Tab: - **Misc. Fields:** -

NBIS: Yes **Toll Road:** Yes **Input Format:** Drop-Down Manual

INDOT: Yes **County/Local:** Yes **X** Check Box Read-Only

Description: "Heavy Duty Truck Route" (continued)

Instructions: See the detailed map below for Heavy Duty Truck Routes in Indiana, which are defined as any route carrying public vehicular traffic within a 15 mile radius of Toll Road exits.

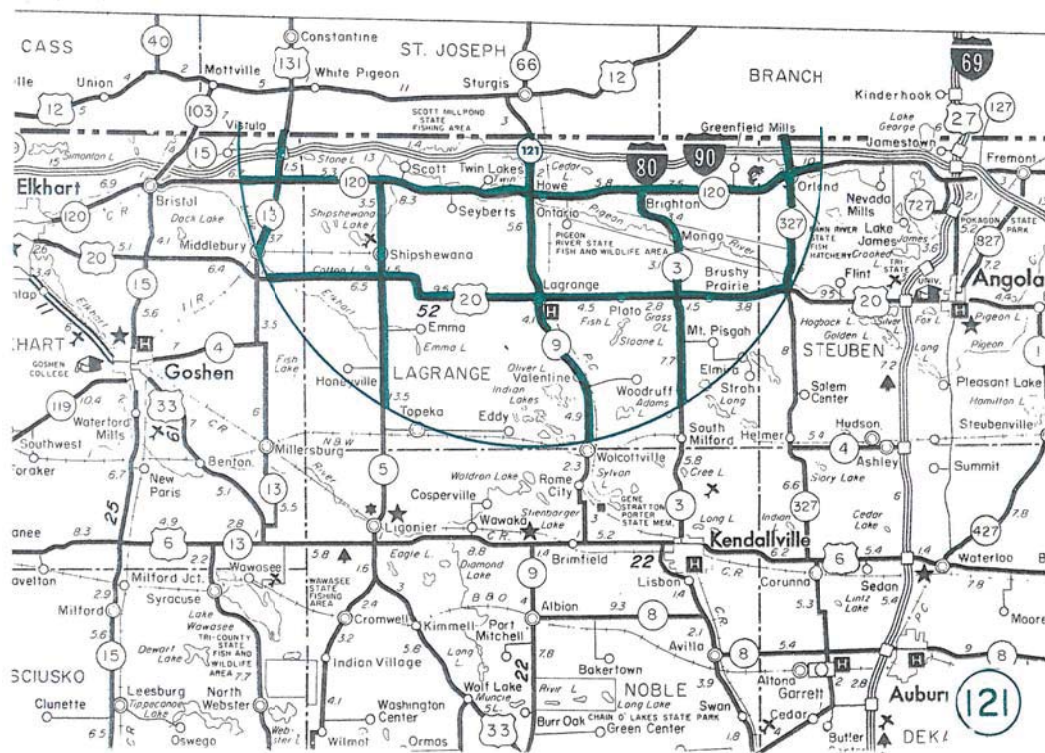

Exit 121

Note that the following are excluded: All Interstate Highways.

Notes: -

INDOT Coding Guide: *Bridge Reporting for Appraisal & Greater Inventory*

Item Number: 501.02 **Item Name:** "Heavy Duty Truck Route"

Main Tab/Sub Tab: Aux. Forms/O.V. (501) **Misc. Fields:** 501 Overall Comments

Main Tab/Sub Tab: Load Rating/Struc. Data (1) **Misc. Fields:** -

Main Tab/Sub Tab: - **Misc. Fields:** -

Main Tab/Sub Tab: - **Misc. Fields:** -

NBIS: Yes **Toll Road:** Yes **Input Format:** Drop-Down Manual

INDOT: Yes **County/Local:** Yes **X** Check Box Read-Only

Description: "Heavy Duty Truck Route" (continued)

Instructions: See the detailed map below for Heavy Duty Truck Routes in Indiana, which are defined as any route carrying public vehicular traffic within a 15 mile radius of Toll Road exits.

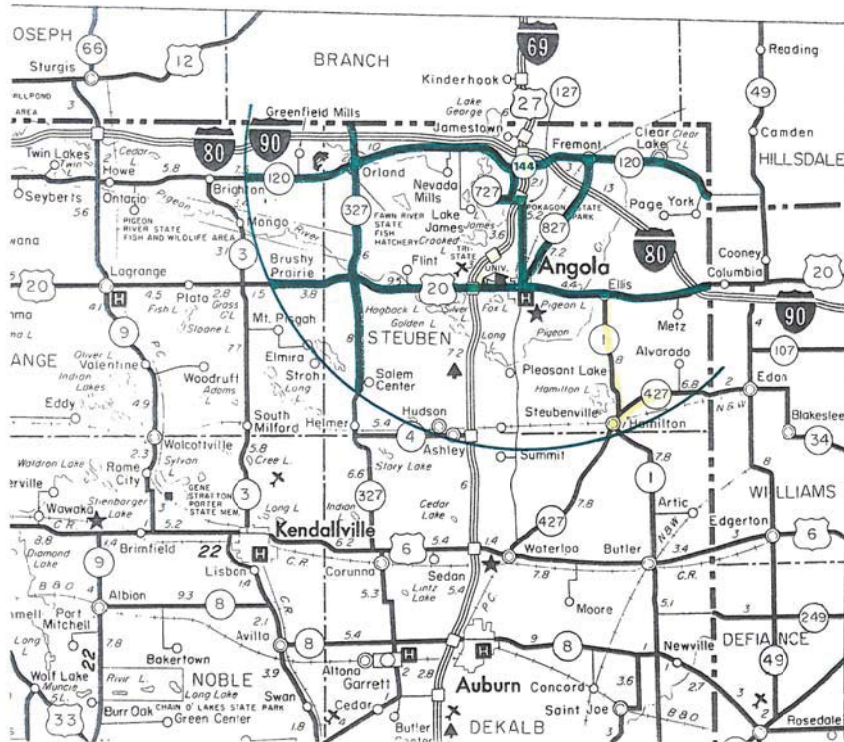

Exit 144

Note that the following are excluded: All Interstate Highways, SR 1, and SR 427.

Notes: -

INDIANA EXTRA HEAVY DUTY HIGHWAYS

North West Indiana

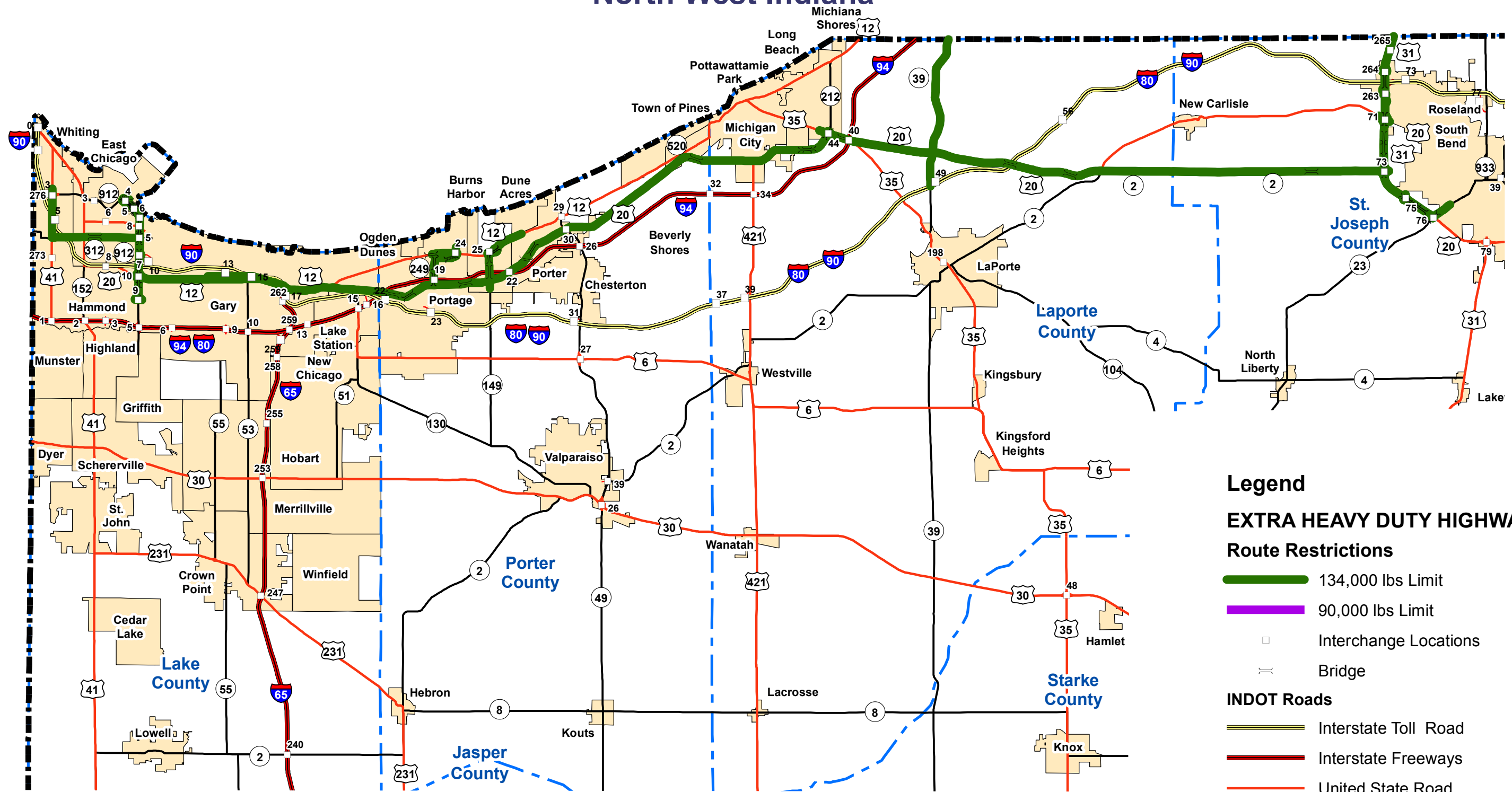



Legend

EXTRA HEAVY DUTY HIGHWAYS

Route Restrictions

 134,000 lbs Limit

 90,000 lbs Limit

 Interchange Locations

 Bridge

INDOT Roads

 Interstate Toll Road

 Interstate Freeways

 United State Road

 State Road

 Interchange Ramps

 INDIANA State Boundary

 County Boundaries



INDIANA EXTRA HEAVY DUTY HIGHWAYS

North East Indiana

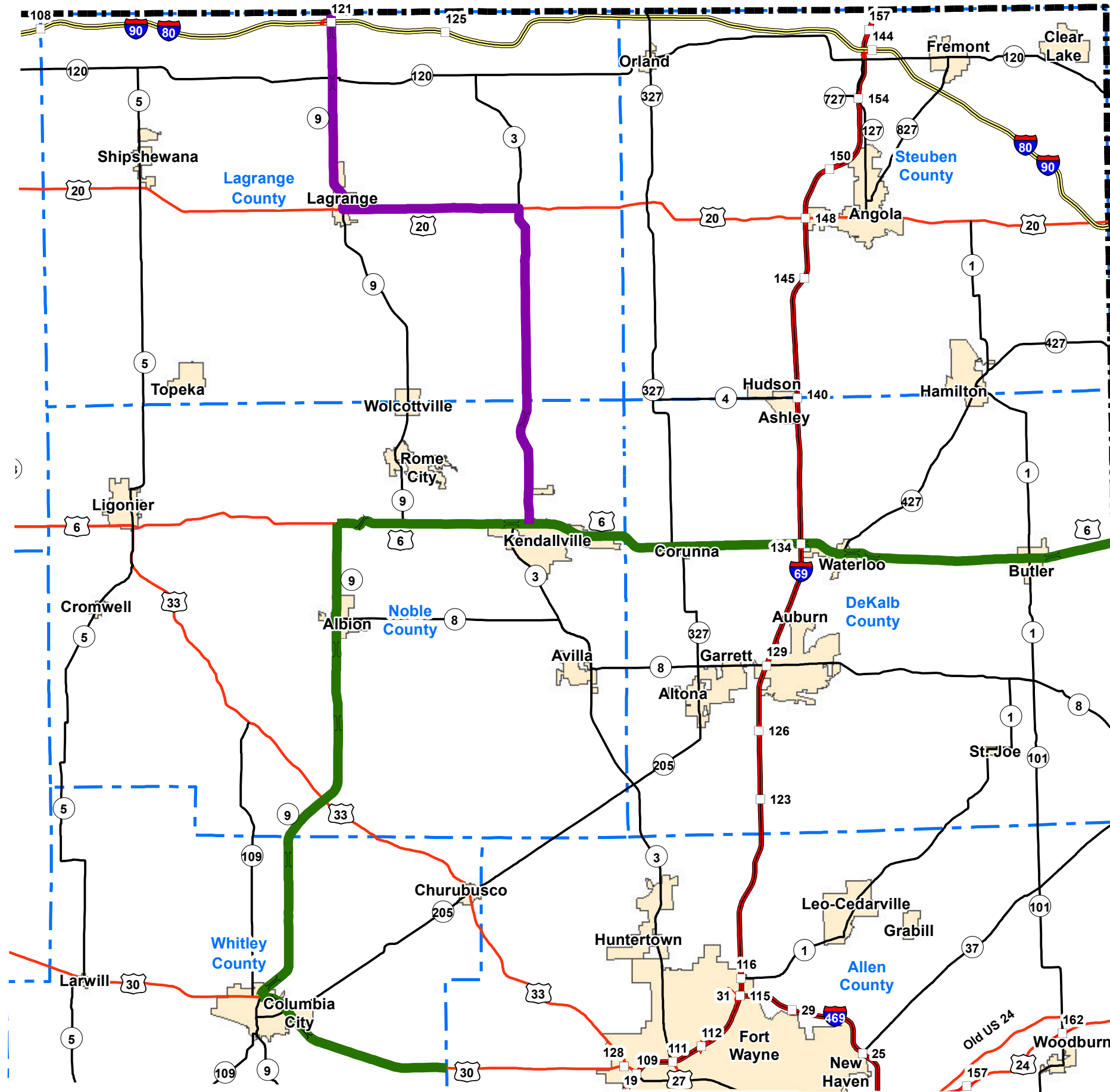

Legend

EXTRA HEAVY DUTY HIGHWAYS

Route Restrictions

- █ 134,000 lbs Limit
- █ 90,000 lbs Limit

- Interchange Locations
- System 1 Bridge

INDOT Roads

- Interstate Toll Road
- Interstate Freeways
- United State Road
- State Road
- Interchange Ramps

- INDIANA State Boundary
- County Boundaries



IC 9-20-5

Chapter 5. Heavy Duty Highways and Extra Heavy Duty Highways

IC 9-20-5-1

Establishment and designation of heavy duty and extra heavy duty highways; removal of designation; publication of map

Sec. 1. (a) The Indiana department of transportation may adopt rules under IC 4-22-2 to do the following:

- (1) Establish and designate a highway as a heavy duty highway.
- (2) Remove the designation of a highway or part of a highway as a heavy duty highway.

(b) The Indiana department of transportation shall adopt rules under IC 4-22-2 to do the following:

- (1) Establish and designate a highway as an extra heavy duty highway.
- (2) Remove the designation of a highway or part of a highway as an extra heavy duty highway.

(c) Rules described in subsection (b)(1) must do the following:

- (1) Designate the highways listed in section 4 of this chapter (before its expiration) as extra heavy duty highways.
- (2) Establish maximum size and weight limits for vehicles operated with a special weight permit on an extra heavy duty highway as set forth in section 5 of this chapter (before its expiration).

(d) The Indiana department of transportation shall periodically publish a map showing all highways designated by the department at the time as heavy duty or extra heavy duty highways.

As added by P.L.2-1991, SEC.8. Amended by P.L.66-2012, SEC.1.

IC 9-20-5-2

Maximum weight limitations; heavy duty highways

Sec. 2. Whenever the Indiana department of transportation designates a heavy duty highway, the department shall also fix the maximum weights of vehicles that may be transported on the highway. The maximum weights may not exceed the following limitations:

- (1) A vehicle may not have a maximum wheel weight, unladen or with load, in excess of eight hundred (800) pounds per inch width of tire, measured between the flanges of the rim, or an axle weight in excess of twenty-two thousand four hundred (22,400) pounds.
- (2) The total weight concentrated on the roadway surface from any tandem axle group may not exceed eighteen thousand (18,000) pounds for each axle of the assembly.
- (3) The total gross weight, with load, in pounds of a vehicle or combination of vehicles may not exceed eighty thousand (80,000) pounds.

As added by P.L.2-1991, SEC.8.

IC 9-20-5-3

Designation of heavy duty highways; conditions

Sec. 3. The Indiana department of transportation may not designate a highway as a heavy duty highway unless the department finds that the highway is:

- (1) so constructed and can be so maintained; or
- (2) in such condition;

that the use of the highway as a heavy duty highway will not materially decrease or contribute materially to the decrease of the ordinary useful life of the highway.

As added by P.L.2-1991, SEC.8. Amended by P.L.198-2016, SEC.340.

IC 9-20-5-4

Extra heavy duty highways; listing; expiration

Sec. 4. (a) In addition to the highways established and designated as heavy duty highways under section 1 of this chapter, the following highways are designated as extra heavy duty highways:

- (1) Highway 41, from 129th Street in Hammond to Highway 312.
- (2) Highway 312, from Highway 41 to State Road 912.
- (3) Highway 912, from Riley Road in East Chicago to the U.S. 20 interchange.
- (4) Highway 20, from Clark Road in Gary to Highway 39.
- (5) Highway 12, from one-fourth (1/4) mile west of the Midwest Steel entrance to Highway 249.
- (6) Highway 249, from Highway 12 to Highway 20.
- (7) Highway 12, from one and one-half (1 1/2) miles east of the Bethlehem Steel entrance to Highway 149.
- (8) Highway 149, from Highway 12 to a point thirty-six hundredths (.36) of a mile south of Highway 20.
- (9) Highway 39, from Highway 20 to the Michigan state line.
- (10) Highway 20, from Highway 39 to Highway 2.
- (11) Highway 2, from Highway 20 to Highway 31.
- (12) Highway 31, from the Michigan state line to Highway 23.
- (13) Highway 23, from Highway 31 to Olive Street in South Bend.
- (14) Highway 35, from South Motts Parkway thirty-four hundredths (.34) of a mile southeast to the point where Highway 35 intersects with the overpass for Highway 20/Highway 212.
- (15) State Road 249 from U.S. 12 to the point where State Road 249 intersects with Nelson Drive at the Port of Indiana.
- (16) State Road 912 from the 15th Avenue and 169th Street interchange one and six hundredths (1.06) miles north to the U.S. 20 interchange.

(17) U.S. 20 from the State Road 912 interchange three and seventeen hundredths (3.17) miles east to U.S. 12.

(18) U.S. 6 from the Ohio state line to State Road 9.

(19) U.S. 30 from Allen County/Whitley County Line Road (also known as County Road 800 East) to State Road 9.

(20) State Road 9 from U.S. 30 to U.S. 6.

(21) State Road 39 from Interstate 80 to U.S. 20.

(22) State Road 3 north from U.S. 6 to U.S. 20, U.S. 20 west from State Road 3 to State Road 9, State Road 9 north from U.S. 20 to the Michigan state line. However, the total gross weight, with load, of a vehicle or combination of vehicles operated with a special weight permit on these highways may not exceed ninety thousand (90,000) pounds.

(23) Highway 912, at an intersection approximately thirty hundredths (.30) of a mile southwest of the intersection of Dickey Road and Riley Road in East Chicago. The total gross weight, with load, of a vehicle or combination of vehicles operated with a special weight permit on this highway may not exceed two hundred sixty-four thousand (264,000) pounds.

(b) This section expires on the later of the following dates:

(1) The date on which rules described in section 1(c)(1) of this chapter are finally adopted.

(2) December 31, 2014.

As added by P.L.2-1991, SEC.8. Amended by P.L.12-1991, SEC.4; P.L.123-1993, SEC.1; P.L.124-1993, SEC.1; P.L.119-1995, SEC.2; P.L.45-1999, SEC.1; P.L.79-2000, SEC.3; P.L.147-2002, SEC.2; P.L.10-2004, SEC.1; P.L.17-2006, SEC.1; P.L.134-2007, SEC.1; P.L.120-2011, SEC.1; P.L.66-2012, SEC.2.

IC 9-20-5-4.5

Repealed

(Repealed by P.L.123-1993, SEC.2.)

IC 9-20-5-5

Maximum size and weight limitations; extra heavy duty highways; expiration

Sec. 5. (a) Except as provided in subsection (b), the maximum size and weight limits for vehicles operated with a special weight permit on an extra heavy duty highway are as follows:

(1) A vehicle may not have a maximum wheel weight, unladen or with load, in excess of eight hundred (800) pounds per inch width of tire, measured between the flanges of the rim.

(2) A single axle weight may not exceed eighteen thousand (18,000) pounds.

(3) An axle in an axle combination may not exceed thirteen thousand (13,000) pounds per axle, with the exception of one

(1) tandem group that may weigh sixteen thousand (16,000) pounds per axle or a total of thirty-two thousand (32,000)

pounds.

(4) Except as provided in section 4(a)(22) of this chapter, the total gross weight, with load, of any vehicle or combination of vehicles may not exceed one hundred thirty-four thousand (134,000) pounds.

(5) Axle spacings may not be less than three (3) feet, six (6) inches, between each axle in an axle combination.

(6) Axle spacings may not be less than eight (8) feet between each axle or axle combination.

(b) A vehicle operated in accordance with section 4(a)(23) of this chapter may not have a:

(1) maximum wheel weight, unladen or with load, in excess of one thousand six hundred fifty (1,650) pounds per inch width of tire, measured between the flanges of the rim; or

(2) single axle weight that exceeds sixty-five thousand (65,000) pounds.

(c) This section expires on the later of the following dates:

(1) The date on which rules described in section 1(c)(2) of this chapter are finally adopted.

(2) December 31, 2014.

As added by P.L.2-1991, SEC.8. Amended by P.L.134-2007, SEC.2; P.L.120-2011, SEC.2; P.L.66-2012, SEC.3; P.L.13-2013, SEC.35.

IC 9-20-5-6

Safety procedures; implementation

Sec. 6. The Indiana department of transportation shall implement procedures that, in cooperation with the state police department and local police departments, enhance the safety of citizens along and near extra heavy duty highways listed in section 4 of this chapter (before its expiration) or described in rules adopted by the Indiana department of transportation under section 1 of this chapter.

As added by P.L.2-1991, SEC.8. Amended by P.L.66-2012, SEC.4.

IC 9-20-5-7

Special weight permits; extra heavy duty highways; fee; additional permit fee

Sec. 7. (a) The owner or operator of a vehicle or combination of vehicles having a total gross weight in excess of eighty thousand (80,000) pounds but less than two hundred sixty-four thousand (264,000) pounds must:

(1) obtain a special weight registration permit;

(2) register annually and pay annually a registration fee to the department of state revenue; and

(3) install an approved automated vehicle identifier in each vehicle operating with a special weight permit;

to travel on an extra heavy duty highway.

(b) The fee for an annual registration under subsection (a) is twenty-five dollars (\$25). The fee imposed under this section must

be deposited in the motor carrier regulation fund established under IC 8-2.1-23.

(c) The department of state revenue may impose an additional permit fee in an amount that may not exceed one dollar (\$1) on each trip permitted for a vehicle registered under subsection (a). This additional fee is for the use and maintenance of an automated vehicle identifier. The fee imposed under this section must be deposited in the motor carrier regulation fund established under IC 8-2.1-23.

As added by P.L.2-1991, SEC.8. Amended by P.L.122-1993, SEC.2; P.L.129-2001, SEC.30; P.L.120-2011, SEC.3; P.L.198-2016, SEC.341.

IC 9-20-5-8

Conditions under which permits not to be issued

Sec. 8. The Indiana department of transportation may not issue a permit under this chapter for the operation of a vehicle if any of the following conditions apply:

- (1) The owner or operator of the vehicle has not complied with IC 8-2.1-24.
- (2) The owner or operator of the vehicle has not provided the Indiana department of transportation with the owner's or operator's Social Security number or federal identification number.
- (3) The owner or operator of the vehicle has not registered the vehicle with the bureau, if the vehicle is required to be registered under IC 9-18.

As added by P.L.122-1993, SEC.3. Amended by P.L.110-1995, SEC.30.

LOAD RATING SUMMARY

For

BRIDGE DETERIORATION/CRITICAL FIND

BRIDGE NUMBER

XXX-XX-XXXXX

NBI NUMBER

XXXXXX

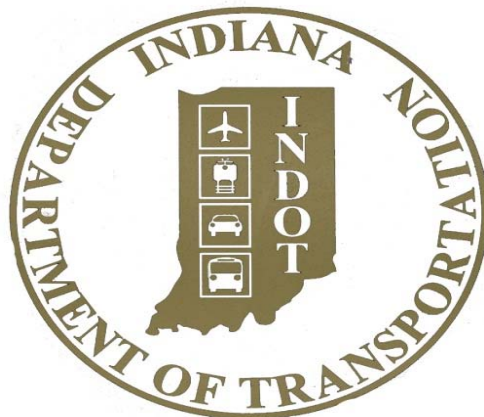

| | | | |
|----------------|------------------------------------|-----------------|--------------|
| Bridge #: | XXX-XX-XXXXX | Load Rater: | SBH 4/1/2017 |
| NBI #: | XXXXXX | Reviewer: | JCH 4/3/2017 |
| Rating Type: | Bridge Deterioration/Critical Find | Rating Program: | BrR 6.8.1 |
| Rating Method: | LRFR | Rating Units: | US Customary |

IDENTIFICATION

Structure Type: CPCIB - Continuous Prestressed Concrete I-Beam Bridge
 Description: Three (3) Span / Twelve (12) Beam System

| | | | |
|-----------------|-----------------|----------------------|------|
| County: | 49 - Marion | Year Built: | 1976 |
| District: | 03 - Greenfield | Years Reconstructed: | 1994 |
| Reference Post: | 21+75 | | |

GEOMETRY

Spans: 45'-0", 55'-0", 45'-0"
 Girder Spacing: 11 @ 6'-6"
 O-to-O Coping: 77'-0"
 Clear Roadway: 74'-0"
 Left Overhang: 2'-9"
 Skew: 30° 00' 00" RT

DECK

| | | | |
|-------------------------|--------|------------------|--------|
| Original Thickness: | 8" | Concrete f'c = | 5 ksi |
| Structural Depth: | 6.5" | Reinforcing Fy = | 60 ksi |
| Additional Overlay: | N/A | | |
| Future Wearing Surface: | 35 psf | | |
| Stay-in-Place Forms: | 15 psf | | |

CONCRETE BEAMS

| | | | | |
|----------------|------------------|--------------------------|-----------------|-------|
| AASHTO Type II | Reinforcing Fy = | 60 ksi | Concrete f'c = | 5 ksi |
| | Strand Material: | 1/2" Ø (7W-270ksi) SP LL | Concrete f'ci = | 4 ksi |

STEEL BEAMS

| | | |
|-----------|-------------------|-----------------------|
| W33 x 130 | Structural Steel: | ASTM - A709 Grade 50W |
| | Structural Steel: | |
| | Structural Steel: | |

REHAB SUMMARY

Rehab A: miscellaneous patching and new rail

NOTES

| | | | |
|----------------|------------------------------------|-----------------|--------------|
| Bridge #: | XXX-XX-XXXXX | Load Rater: | SBH 4/1/2017 |
| NBI #: | XXXXXX | Reviewer: | JCH 4/3/2017 |
| Rating Type: | Bridge Deterioration/Critical Find | Rating Program: | BrR 6.8.1 |
| Rating Method: | LRF | Rating Units: | US Customary |

DESIGN LOADS

(future wearing surface ==> 35 psf)

| Applicable Design Vehicle | Vehicle Configuration | Inventory Rating Factors |
|-------------------------------------|-----------------------------------|--------------------------|
| <input checked="" type="checkbox"/> | HL-93 | 0.400 |
| <input checked="" type="checkbox"/> | Fatigue | 1.310 |
| <input checked="" type="checkbox"/> | H-20 | 0.842 |
| <input checked="" type="checkbox"/> | HS-20 | 0.842 |
| <input type="checkbox"/> | <i>HS-25</i> | |
| <input type="checkbox"/> | <i>Alternate Military</i> | |
| <input type="checkbox"/> | <i>Toll Road Loading NO. 2</i> | |
| <input type="checkbox"/> | <i>Toll Road Loading NO. 1</i> | |
| <input type="checkbox"/> | <i>Special Toll Road Truck</i> | |
| <input type="checkbox"/> | <i>Michigan Train Truck NO. 5</i> | |
| <input type="checkbox"/> | <i>Michigan Train Truck NO. 8</i> | |

NOTES

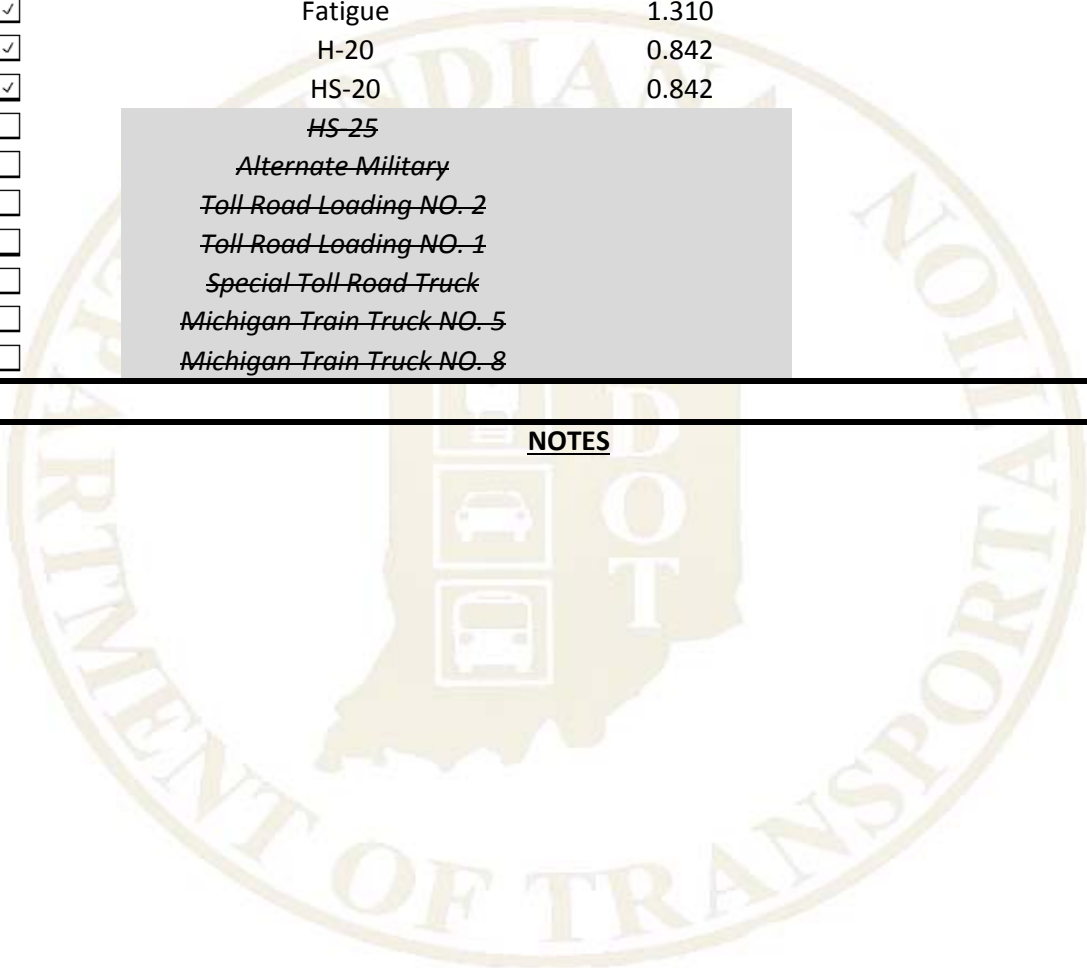

| | | | |
|----------------|------------------------------------|-----------------|--------------|
| Bridge #: | XXX-XX-XXXXX | Load Rater: | SBH 4/1/2017 |
| NBI #: | XXXXXX | Reviewer: | JCH 4/3/2017 |
| Rating Type: | Bridge Deterioration/Critical Find | Rating Program: | BrR 6.8.1 |
| Rating Method: | LRFR | Rating Units: | US Customary |

LEGAL & ROUTINE PERMIT LOADS

(future wearing surface NOT included)

| # of Axles | Vehicle Configuration | Rating Factors | Load Capacity (tons) | Safe Posting Load (tons) |
|------------|-----------------------|----------------|----------------------|--------------------------|
| 2 | EV2 | 0.834 | 23.98 | |
| 3 | EV3 | 0.581 | 24.98 | |
| | | | Single Axle | 13.97 |
| | | | Tandem | 18.01 |
| | | | Gross | 23.98 |

| Applicable Routine Permit | # of Axles | Vehicle Configuration | Rating Factors | Load Capacity (tons) | Safe Posting Load (tons) |
|-------------------------------------|------------|--------------------------------|----------------|----------------------|--------------------------|
| | varies | NRL | 0.945 | 22.12 | 22.12 |
| | 2 | H20-44 | 1.106 | 22.12 | 22.12 |
| | 2 | Alternate Military | 0.982 | 23.57 | 23.38 |
| | 3 | HS20-44 | 0.671 | 24.16 | 19.08 |
| | 3 | AASHTO Type 3 | 1.510 | 37.75 | 37.75 |
| | 4 | SU4 | 1.380 | 37.26 | 37.26 |
| <input type="checkbox"/> | 4 | <i>Toll Road Loading NO. 2</i> | | | |
| | 5 | AASHTO Type 3S2 | 1.177 | 42.37 | 42.37 |
| | 5 | SU5 | 1.215 | 37.67 | 37.67 |
| <input type="checkbox"/> | 5 | <i>Toll Road Loading NO. 1</i> | | | |
| | 6 | AASHTO Type 3-3 | 1.150 | 46.00 | 46.00 |
| | 6 | Lane-Type | 0.763 | 30.52 | 26.46 |
| | 6 | SU6 | 1.088 | 37.81 | 37.81 |
| <input type="checkbox"/> | 7 | <i>Special Toll Road Truck</i> | | | |
| | 7 / 8 | SU7 | 0.982 | 38.05 | 37.75 |
| <input checked="" type="checkbox"/> | 8 | Michigan Train Truck NO. 5 | 0.646 | 43.28 | 33.12 |
| <input checked="" type="checkbox"/> | 11 | Michigan Train Truck NO. 8 | 0.627 | 42.07 | 31.35 |

NOTES



| | | | |
|----------------|------------------------------------|-----------------|--------------|
| Bridge #: | XXX-XX-XXXXX | Load Rater: | SBH 4/1/2017 |
| NBI #: | XXXXXX | Reviewer: | JCH 4/3/2017 |
| Rating Type: | Bridge Deterioration/Critical Find | Rating Program: | BrR 6.8.1 |
| Rating Method: | LRFR | Rating Units: | US Customary |

SPECIAL PERMIT LOADS

(future wearing surface NOT included)

| # of Axles | Vehicle Configuration | Rating Factors | Load Capacity (tons) |
|------------|-----------------------|----------------|----------------------|
| 11 | Superload | 0.638 | 82.30 |
| 13 | Superload | 0.648 | 86.51 |
| 14 | Superload | 0.548 | 95.90 |
| 19 | Superload (305K) | 0.632 | 96.38 |
| 19 | Superload (480.09K) | 0.525 | 126.02 |

NOTES

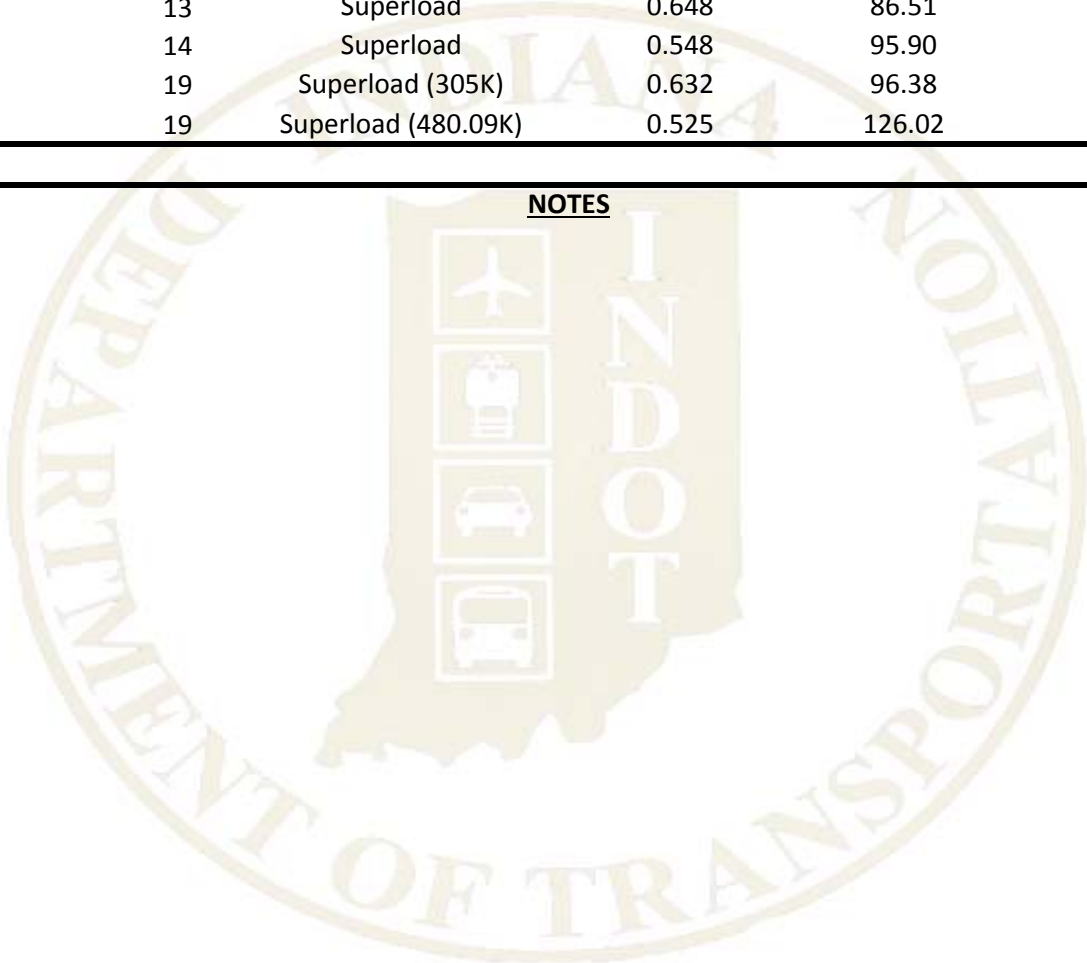

LOAD RATING SUMMARY

For

BRIDGE DETERIORATION/CRITICAL FIND

BRIDGE NUMBER

XXX-XX-XXXXX

NBI NUMBER

XXXXXX



| | | | |
|----------------|------------------------------------|-----------------|--------------|
| Bridge #: | XXX-XX-XXXXX | Load Rater: | SBH 4/1/2017 |
| NBI #: | XXXXXX | Reviewer: | JCH 4/3/2017 |
| Rating Type: | Bridge Deterioration/Critical Find | Rating Program: | N/A |
| Rating Method: | Engineering Judgment | Rating Units: | US Customary |

IDENTIFICATION

| | | | |
|-----------------|-----------------------------|----------------------|---------------------------|
| Structure Type: | Concrete Cast-in-Place Slab | | |
| Description: | Single Span | | |
| County: | 73 - Shelby | Year Built: | 1941 (no plans available) |
| District: | 03 - Greenfield | Years Reconstructed: | 2000 (no plans available) |
| Reference Post: | 44+28 | | |

GEOMETRY

| | |
|-----------------|----------------|
| Spans: | 20'-1" |
| Girder Spacing: | N/A |
| O-to-O Coping: | 44'-6" |
| Clear Roadway: | 42'-0" |
| Left Overhang: | N/A |
| Skew: | 45° 00' 00" LT |

DECK

| | | | |
|-------------------------|---------|-----------------|-----------------|
| Original Thickness: | Unknown | Concrete f'c: | 2.5 ksi assumed |
| Structural Depth: | Unknown | Reinforcing Fy: | 33 ksi assumed |
| Additional Overlay: | Unknown | | |
| Future Wearing Surface: | N/A | | |
| Stay-in-Place Forms: | N/A | | |

CONCRETE BEAMS

| | |
|------------------|----------------|
| Reinforcing Fy: | Concrete f'c: |
| Strand Material: | Concrete f'ci: |

STEEL BEAMS

| |
|-------------------|
| Structural Steel: |
| Structural Steel: |
| Structural Steel: |

REHAB SUMMARY

| | |
|---------|--|
| Rehab A | Wearing surface and bridge railing replaced. |
|---------|--|

NOTES

In accordance with the Manual for Bridge Evaluation, Second Edition, 2011, Section 6.1.4 - Necessary details for this bridge are unavailable. A physical inspection of the bridge was performed by a qualified inspector and evaluated by a qualified engineer to establish an approximate load rating based on rational criteria. Material properties have been assumed based on guidance given in the MBE.

| | | |
|----------------|------------------------------------|----------------------------|
| Bridge #: | XXX-XX-XXXXX | Load Rater: SBH 4/1/2017 |
| NBI #: | XXXXXX | Reviewer: JCH 4/3/2017 |
| Rating Type: | Bridge Deterioration/Critical Find | Rating Program: N/A |
| Rating Method: | Engineering Judgment | Rating Units: US Customary |

DESIGN LOADS*(future wearing surface ==> N/A)*

| Applicable Design Vehicle | Vehicle Configuration | Inventory Rating Factors |
|-------------------------------------|-----------------------------------|--------------------------|
| <input type="checkbox"/> | <i>HL-93</i> | |
| <input type="checkbox"/> | <i>Fatigue</i> | |
| <input checked="" type="checkbox"/> | H-20 | 1.000 |
| <input checked="" type="checkbox"/> | HS-20 | 1.000 |
| <input type="checkbox"/> | <i>HS-25</i> | |
| <input checked="" type="checkbox"/> | Alternate Military | 0.830 |
| <input type="checkbox"/> | <i>Toll Road Loading NO. 2</i> | |
| <input type="checkbox"/> | <i>Toll Road Loading NO. 1</i> | |
| <input type="checkbox"/> | <i>Special Toll Road Truck</i> | |
| <input type="checkbox"/> | <i>Michigan Train Truck NO. 5</i> | |
| <input type="checkbox"/> | <i>Michigan Train Truck NO. 8</i> | |

NOTES

There are no signs of distress or deterioration that would indicate that the current load carrying capacity is less than the design vehicle.

The inventory rating factors are based on the assumption that the bridge was designed for H-20 loading. Ratings for HS-20 and Alternate Military vehicles were determined by inspection of the moments produced by these vehicles compared with the assumed H-20 design vehicle. Shear was assumed to not control for this slab structure.

| | | | |
|----------------|------------------------------------|-----------------|--------------|
| Bridge #: | XXX-XX-XXXXX | Load Rater: | SBH 4/1/2017 |
| NBI #: | XXXXXX | Reviewer: | JCH 4/3/2017 |
| Rating Type: | Bridge Deterioration/Critical Find | Rating Program: | N/A |
| Rating Method: | Engineering Judgment | Rating Units: | US Customary |

LEGAL & ROUTINE PERMIT LOADS

(future wearing surface NOT included)

| # of Axles | Vehicle Configuration | Rating Factors | Load Capacity (tons) | Safe Posting Load (tons) |
|------------|-----------------------|----------------|----------------------|--------------------------|
| 2 | EV2 | 1.000 | 28.75 | |
| 3 | EV3 | 1.000 | 43.00 | |
| | | | Single Axle | N/A |
| | | | Tandem | N/A |
| | | | Gross | N/A |

| Applicable Routine Permit | # of Axles | Vehicle Configuration | Rating Factors | Load Capacity (tons) | Safe Posting Load (tons) |
|---------------------------|------------|-----------------------------------|----------------|----------------------|--------------------------|
| | varies | NRL | 1.000 | 20.00 | N/A |
| | 2 | H20-44 | 1.000 | 20.00 | N/A |
| | 2 | Alternate Military | 1.000 | 24.00 | N/A |
| | 3 | HS20-44 | 1.000 | 36.00 | N/A |
| | 3 | AASHTO Type 3 | 1.000 | 25.00 | N/A |
| | 4 | SU4 | 1.000 | 27.00 | N/A |
| <input type="checkbox"/> | 4 | <i>Toll Road Loading NO. 2</i> | | | |
| | 5 | AASHTO Type 3S2 | 1.000 | 36.00 | N/A |
| | 5 | SU5 | 1.000 | 31.00 | N/A |
| <input type="checkbox"/> | 5 | <i>Toll Road Loading NO. 1</i> | | | |
| | 6 | AASHTO Type 3-3 | 1.000 | 40.00 | N/A |
| | 6 | <i>Lane Type</i> | <i>N/A</i> | <i>N/A</i> | <i>N/A</i> |
| | 6 | SU6 | 1.000 | 34.75 | N/A |
| <input type="checkbox"/> | 7 | <i>Special Toll Road Truck</i> | | | |
| | 7 / 8 | SU7 | 1.000 | 38.75 | N/A |
| <input type="checkbox"/> | 8 | <i>Michigan Train Truck NO. 5</i> | | | |
| <input type="checkbox"/> | 11 | <i>Michigan Train Truck NO. 8</i> | | | |

NOTES

The H-20, HS-20, and Alternate Military legal load rating factors were determined by comparison to their design load factors, but were conservatively limited to 1.0.

The EV2, EV3, AASHTO Type 3, AASHTO Type 3S2, AASHTO Type 3-3, SU4, SU5, SU6, and SU7 rating factors were determined by the assumption that all of these vehicle types have used the bridge in the past, and the inspection results that found no signs of distress or deterioration that would indicate that the current load carrying capacity is less than these legal vehicles.

| | | |
|----------------|------------------------------------|----------------------------|
| Bridge #: | XXX-XX-XXXXX | Load Rater: SBH 4/1/2017 |
| NBI #: | XXXXXX | Reviewer: JCH 4/3/2017 |
| Rating Type: | Bridge Deterioration/Critical Find | Rating Program: N/A |
| Rating Method: | Engineering Judgment | Rating Units: US Customary |

SPECIAL PERMIT LOADS

(future wearing surface NOT included)

| # of Axles | Vehicle Configuration | Rating Factors | Load Capacity (tons) |
|------------|-----------------------|----------------|----------------------|
| 11 | Superload | 0.700 | 90.30 |
| 13 | Superload | 0.800 | 106.80 |
| 14 | Superload | 0.600 | 105.00 |
| 19 | Superload (305K) | 0.900 | 137.25 |
| 19 | Superload (480.09K) | 0.700 | 168.03 |

NOTES

The Superload rating factors were determined by comparing the moments caused by these vehicles to the maximum moment caused by Legal Load vehicles with a 1.0 rating factor, as shown on the 'LEGAL & ROUTINE PERMIT LOADS' table.

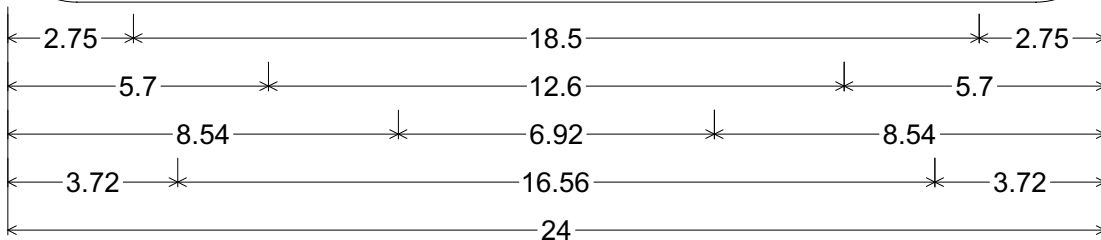
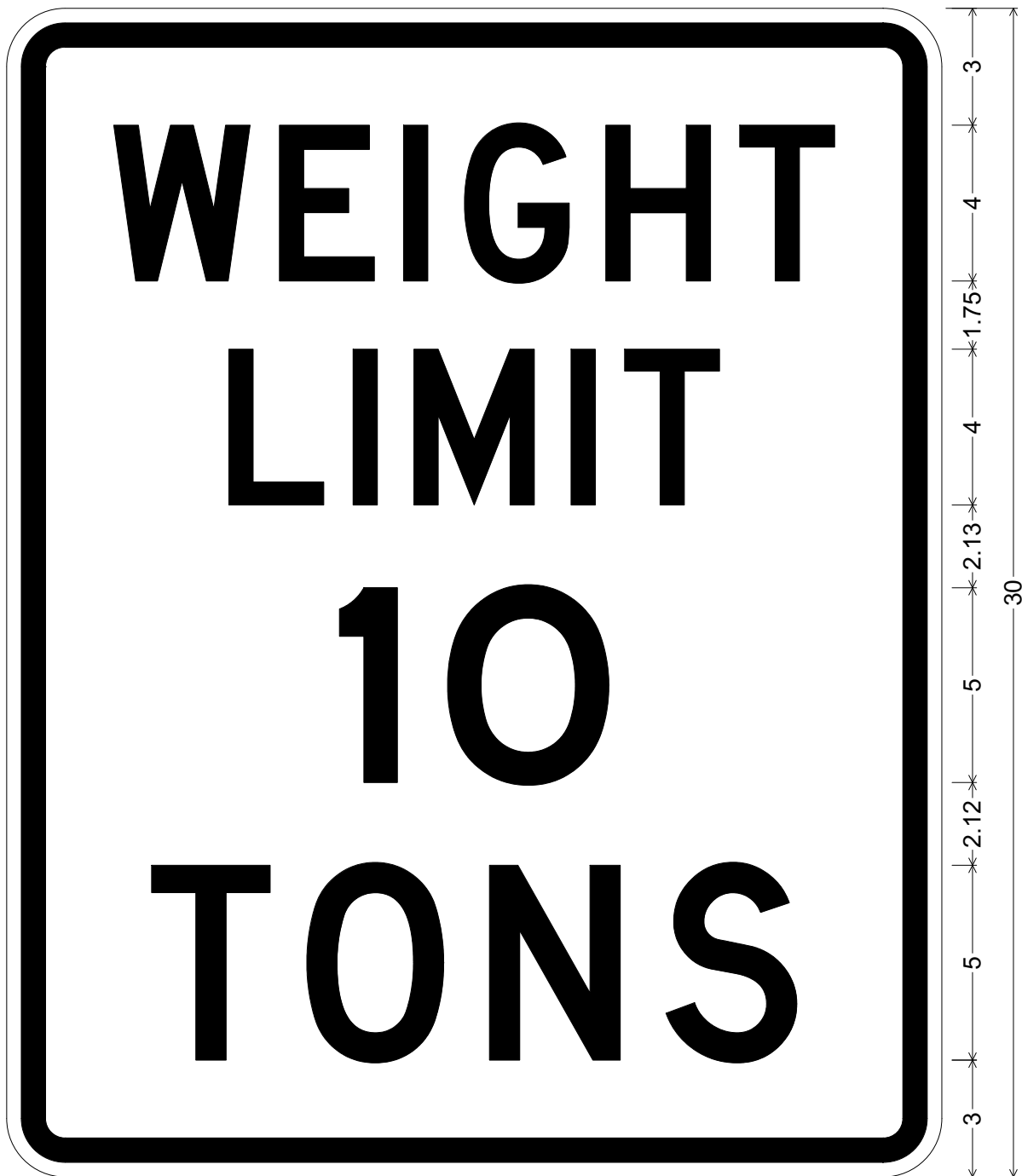

1.50" Radius, 0.63" Border, 0.38" Indent, Black on White;
"WEIGHT" D; "LIMIT" D; "10" E; "TONS" D;

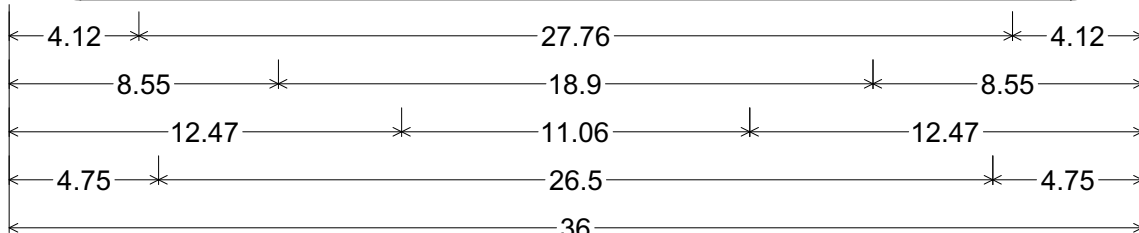

2.25" Radius, 0.88" Border, 0.63" Indent, Black on White;
"WEIGHT" D; "LIMIT" D; "10" E; "TONS" D;

R12-Y1P 30"x18"

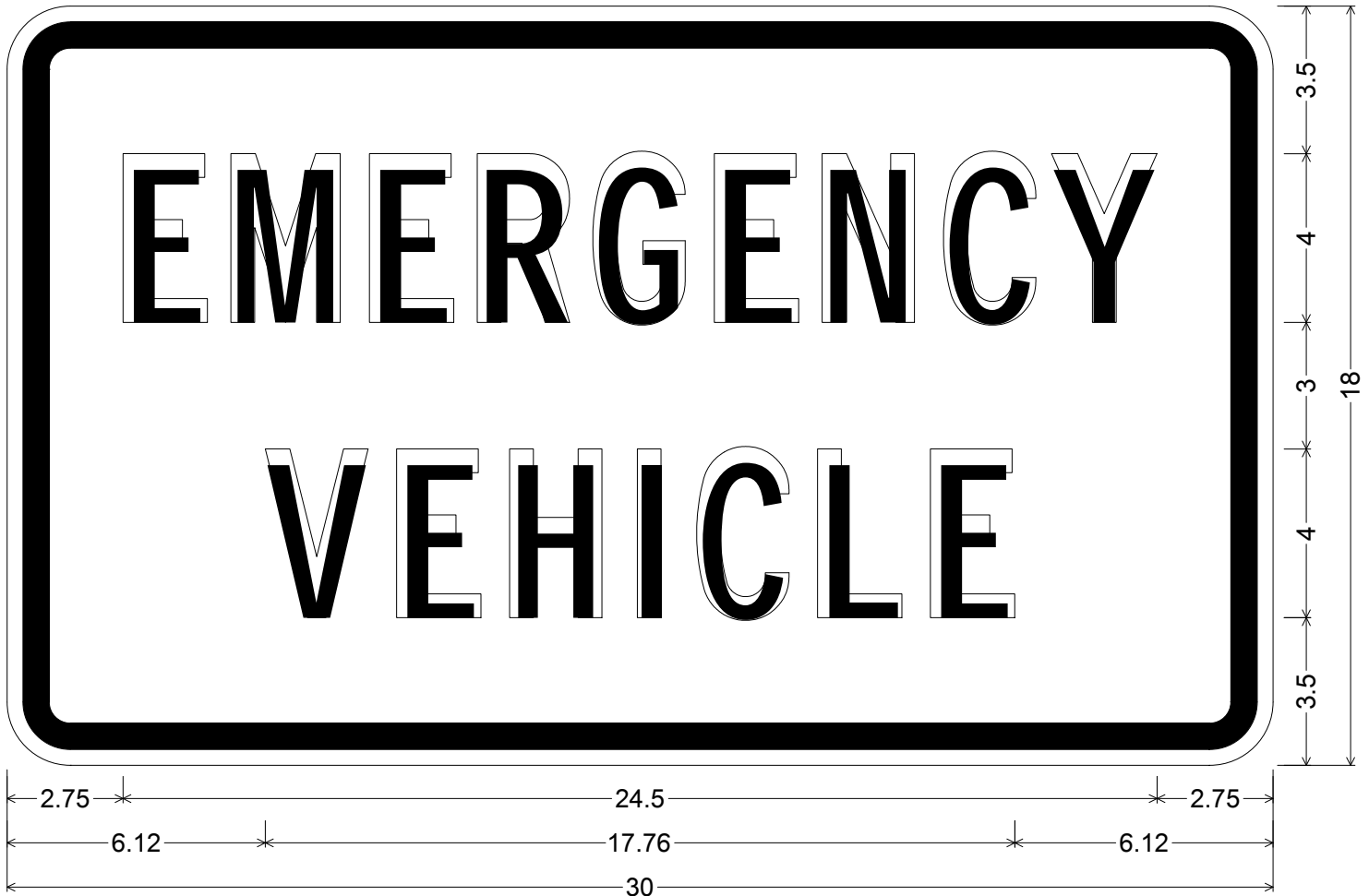

1.50" Radius, 0.63" Border, 0.38" Indent, Black on White;
"EMERGENCY" C 82% spacing; "VEHICLE" C;

R12-Y4-EVa 60"x30"

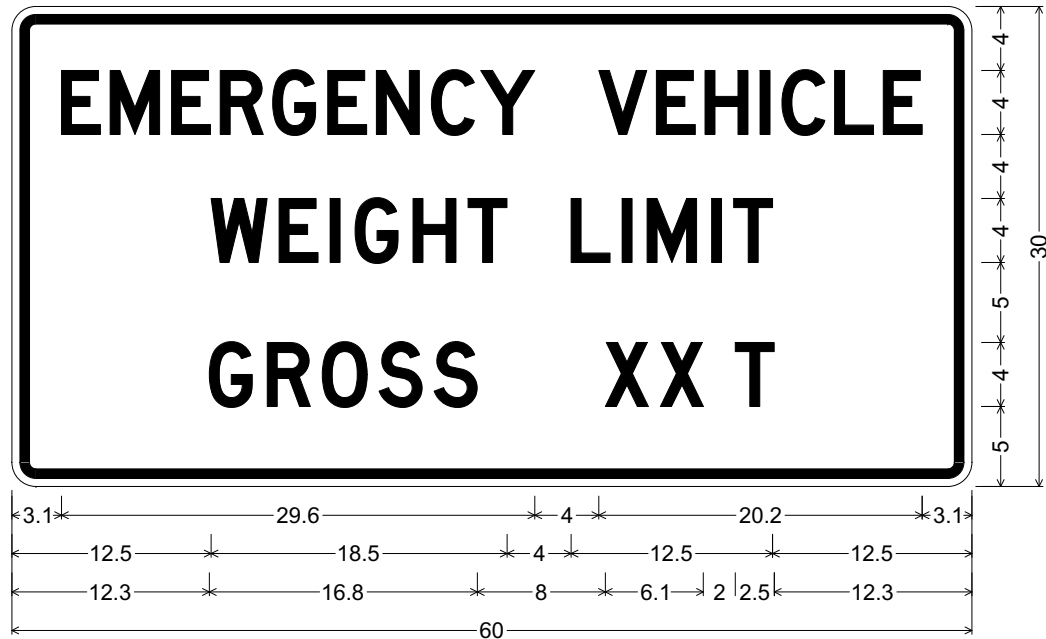

Identifier : 80113574 R12-Y4-EV(a) 60x30

1.5" Radius, 0.6" Border, 0.5" Indent, Black on White;

"EMERGENCY VEHICLE" D 80% spacing; "WEIGHT LIMIT" D; "GROSS XX T" D;

R12-Y4-EVa 78"x36"

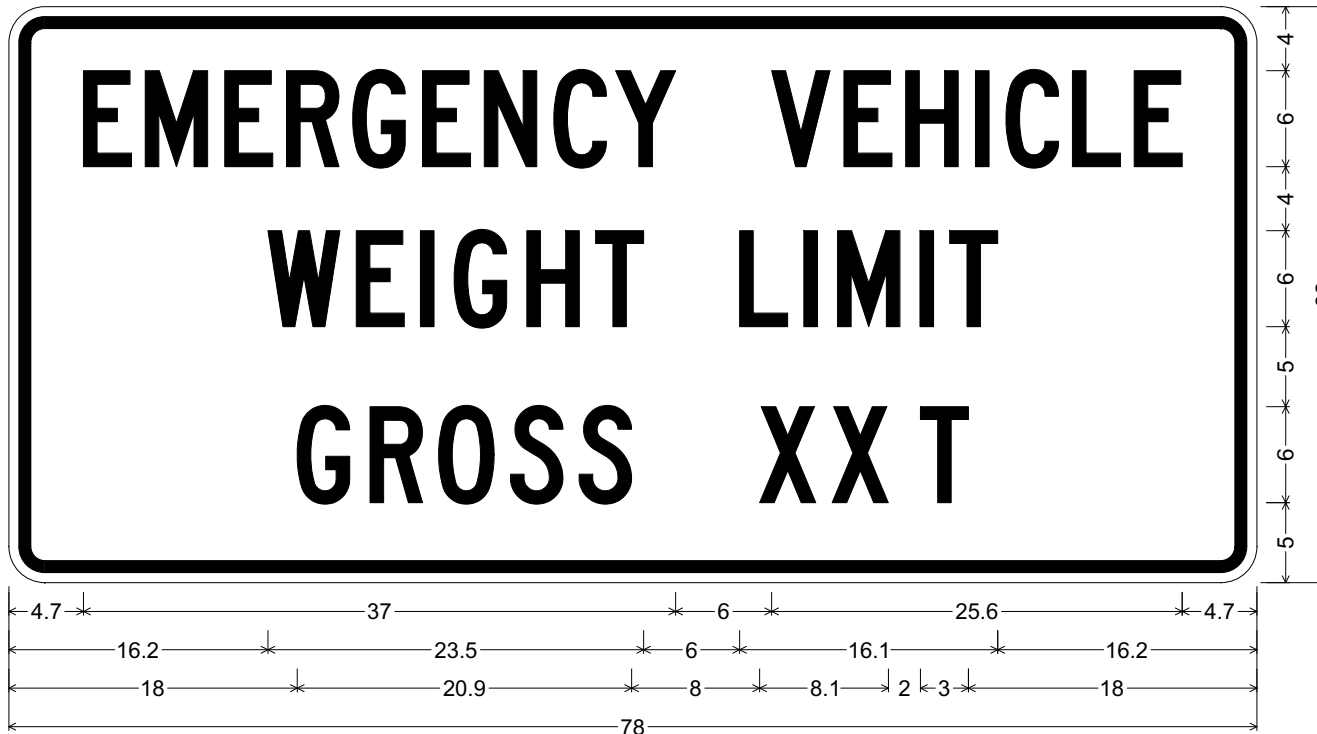

Identifier : 80113571 R12-Y4-EV(a) 78x36

2.3" Radius, 0.8" Border, 0.6" Indent, Black on White;

"EMERGENCY VEHICLE" C 85% spacing; "WEIGHT LIMIT" C; "GROSS XX T" C;

R12-Y4-EVb 60"x36"

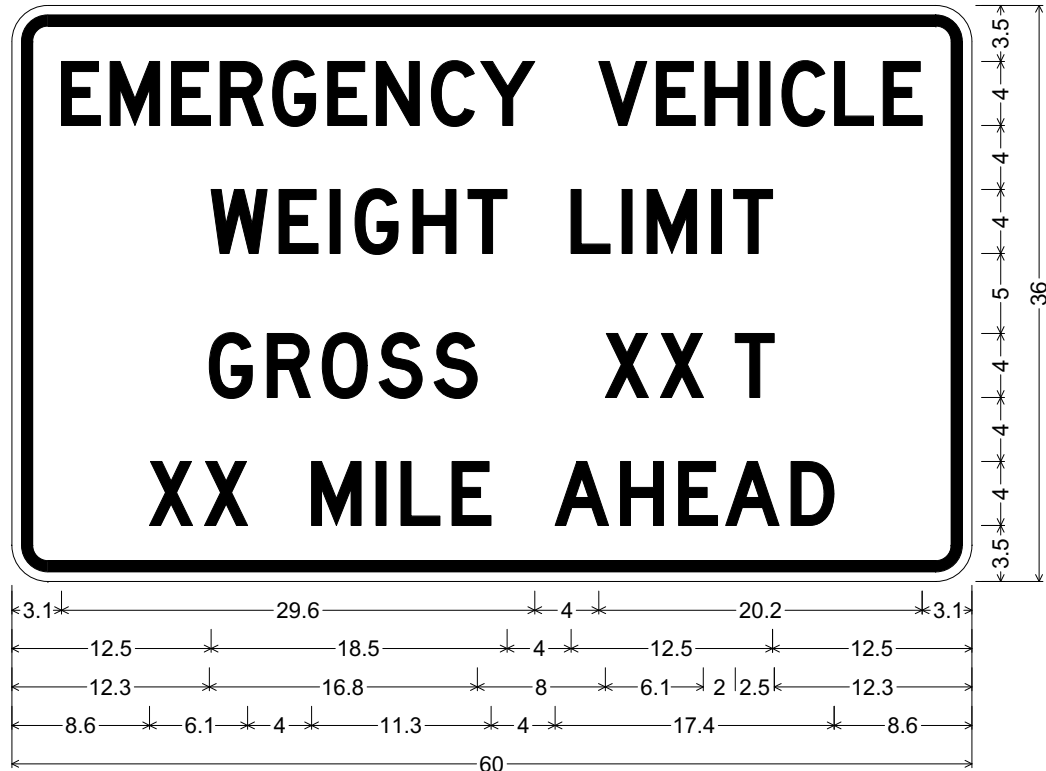

Identifier : 80113573 R12-Y4-EV(b) 60x36

2.3" Radius, 0.7" Border, 0.6" Indent, Black on White;

"EMERGENCY VEHICLE" D 80% spacing; "WEIGHT LIMIT" D; "GROSS XX T" D;

"XX MILE AHEAD" D;

R12-Y4-EVb 78"x48"

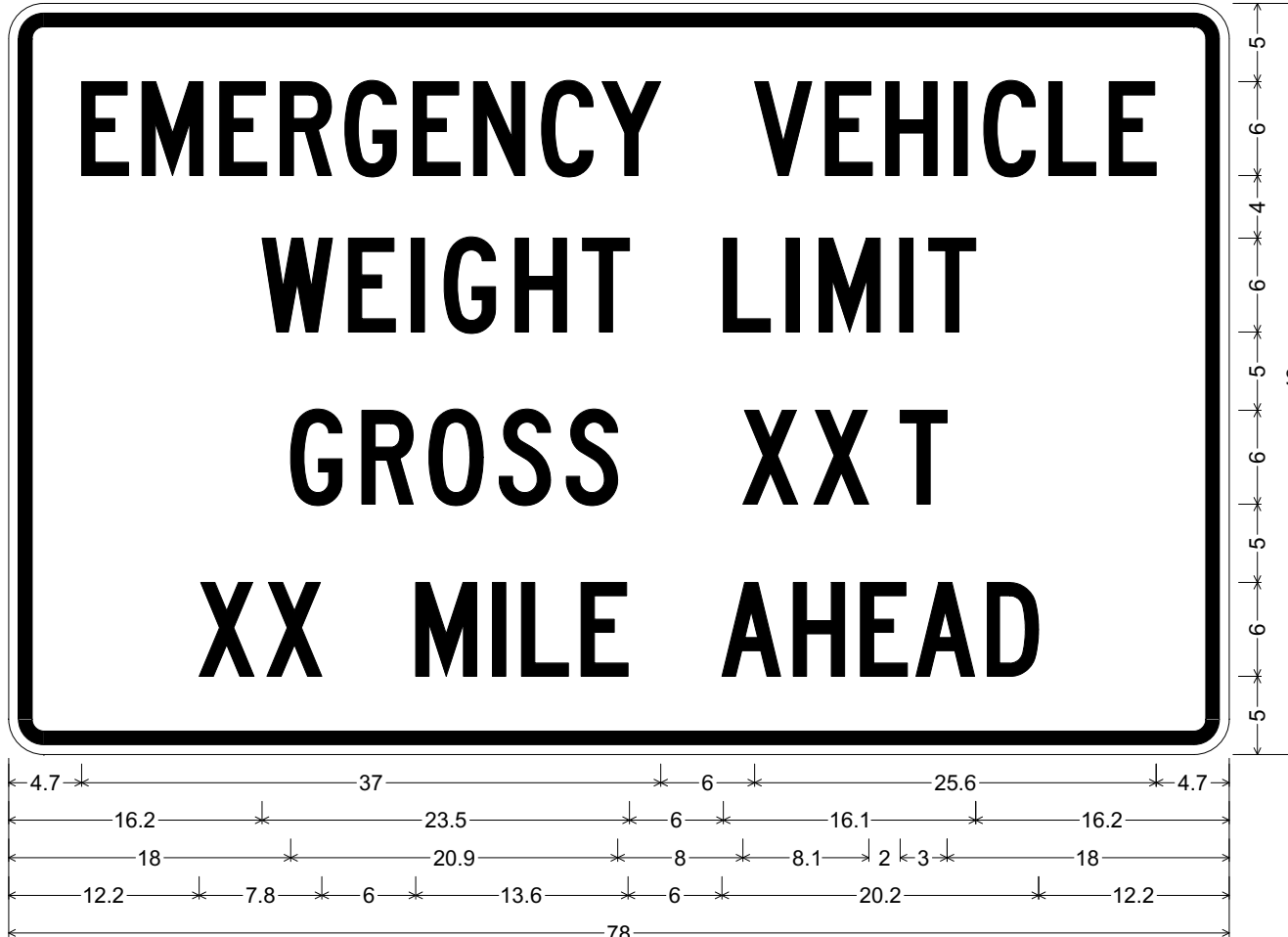

Identifier : 80113572 R12-Y4-EV(b) 78x48

2.3" Radius, 0.9" Border, 0.6" Indent, Black on White;

"EMERGENCY VEHICLE" C 85% spacing; "WEIGHT LIMIT" C; "GROSS XX T" C; "XX MILE AHEAD" C 80% spacing;

R12-Y4-EVc 60"x36"

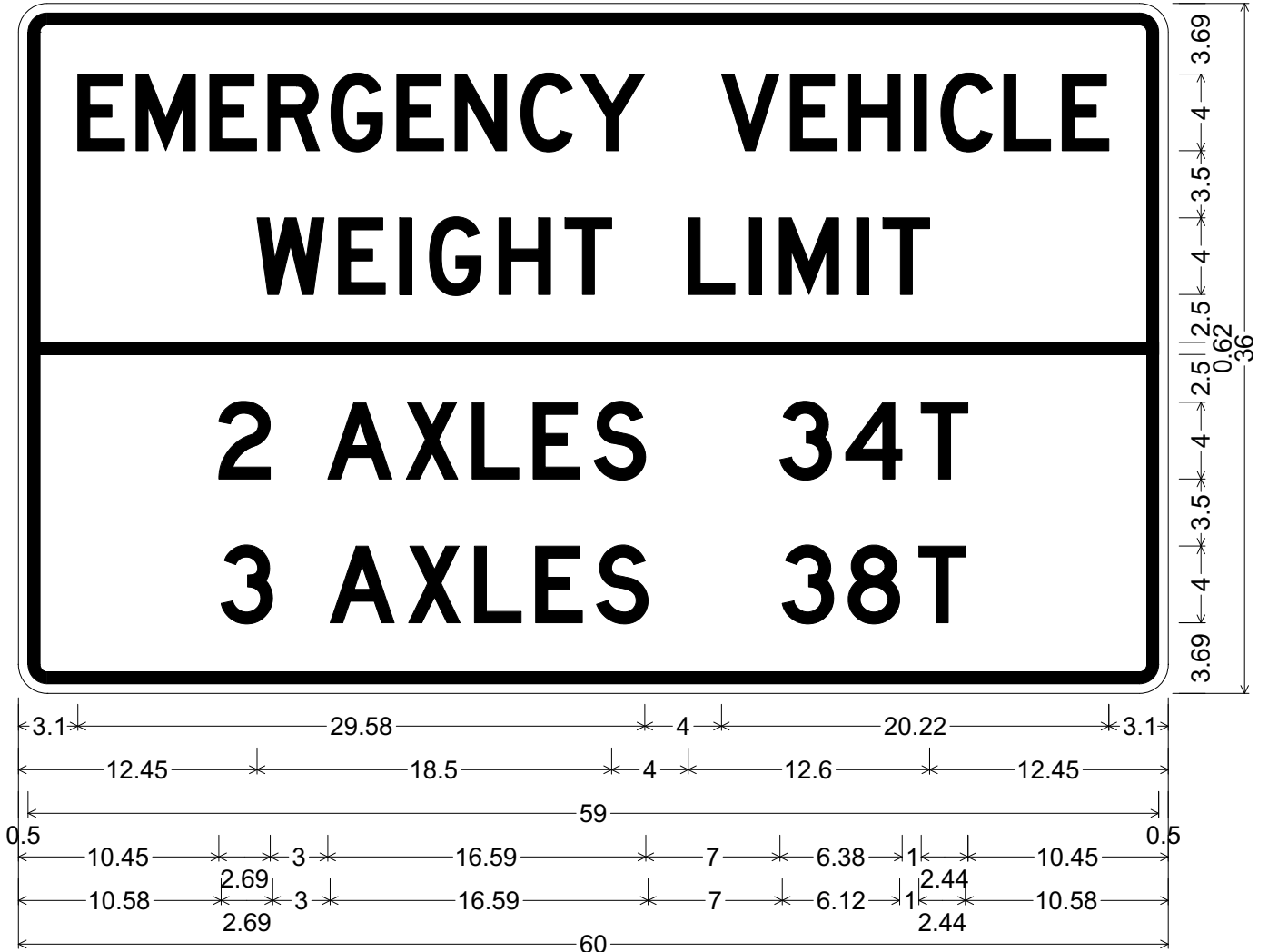

1.50" Radius, 0.63" Border, 0.50" Indent, Black on White;
"EMERGENCY VEHICLE" D 80% spacing; "WEIGHT LIMIT" D; "2 AXLES" D; "34 T" D;
"3 AXLES" D; "38 T" D;

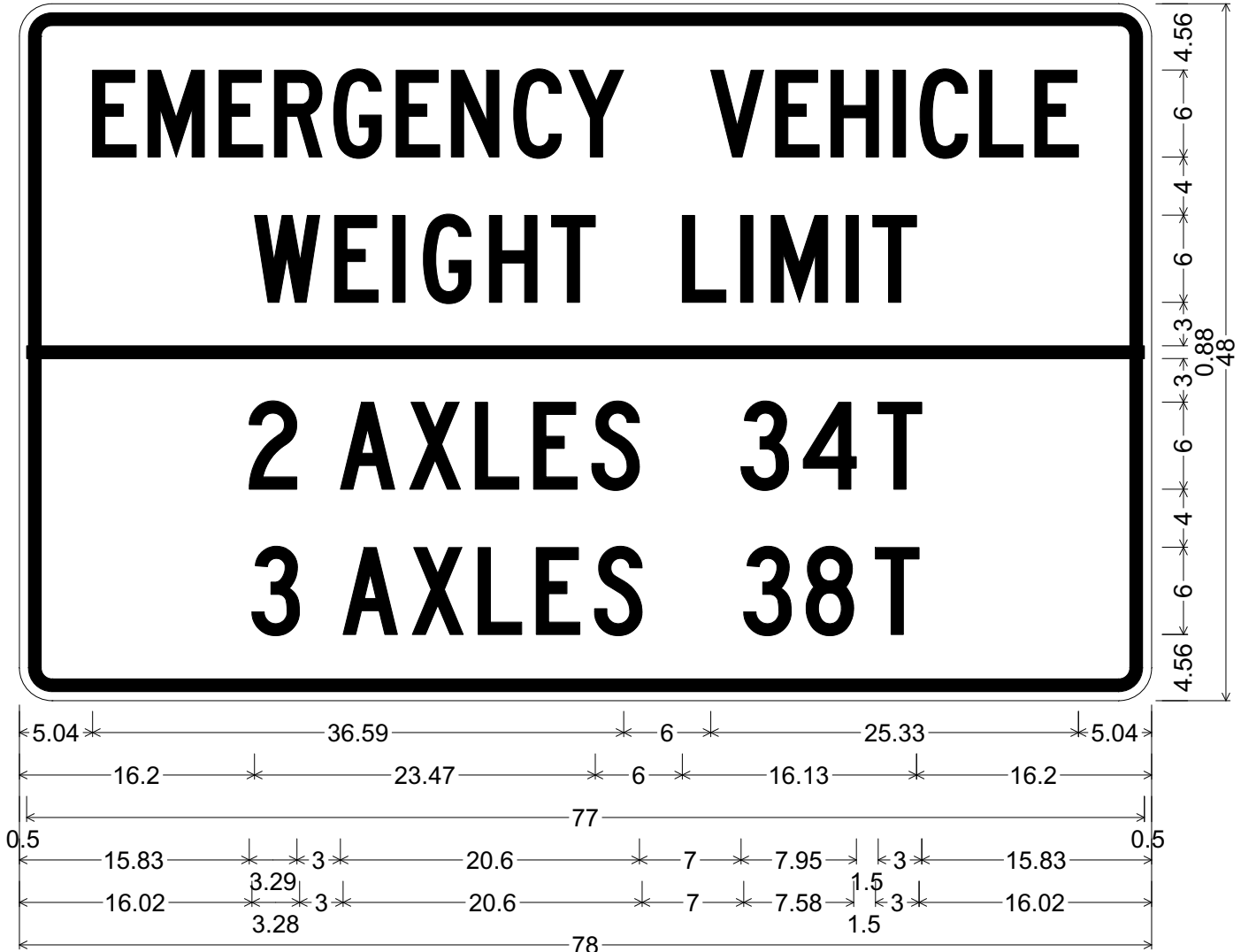

2.25" Radius, 0.88" Border, 0.63" Indent, Black on White;
 "EMERGENCY VEHICLE" C 80% spacing; "WEIGHT LIMIT" C; "2" C " " D "AXLES" C;
 "34" C " " D "T" C; "3" C " " D "AXLES" C; "38" C " " D "T" C;

R12-Y4-EVd 60"x36"

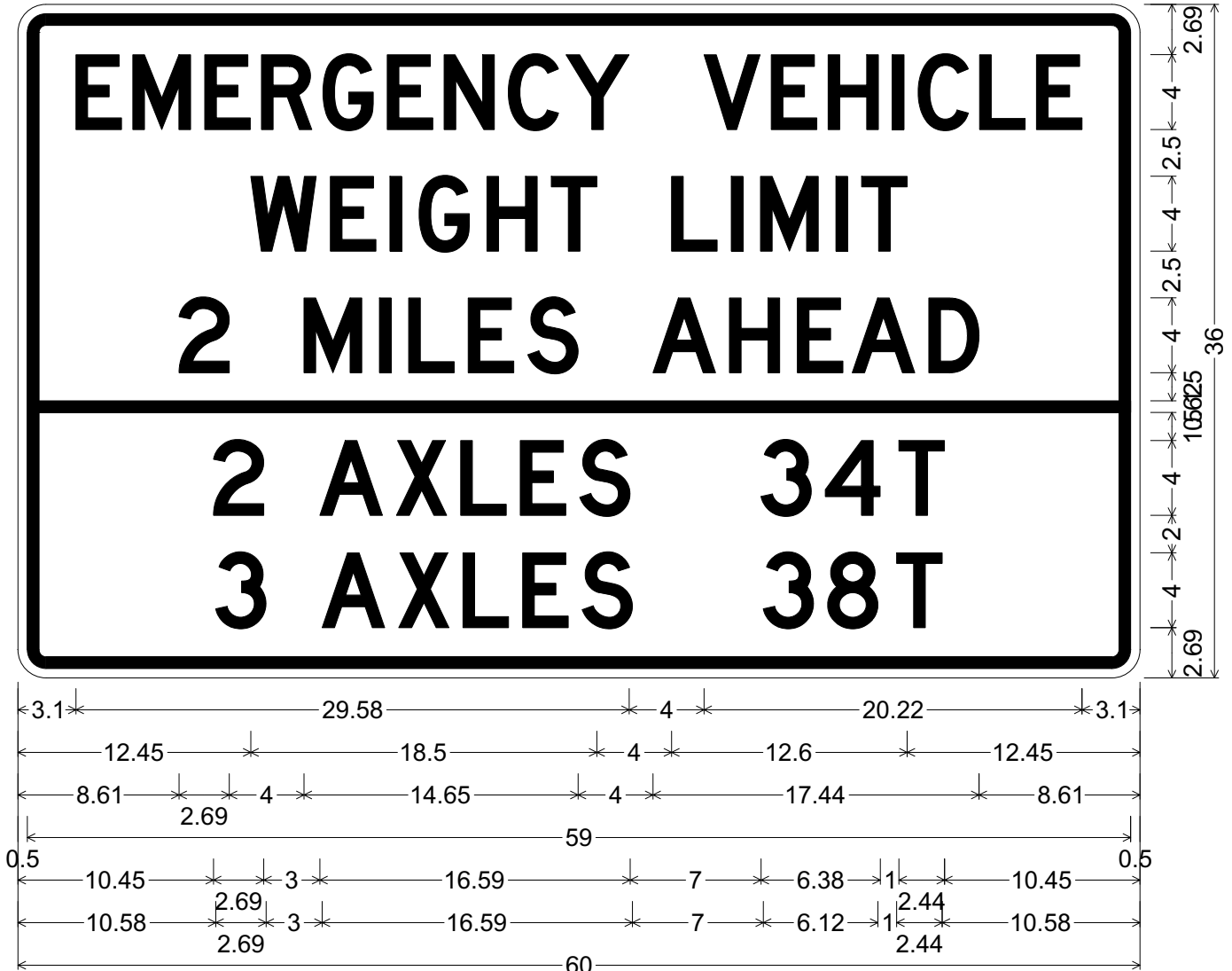

1.50" Radius, 0.63" Border, 0.50" Indent, Black on White;
"EMERGENCY VEHICLE" D 80% spacing; "WEIGHT LIMIT" D; "2 MILES AHEAD" D;
"2 AXLES" D; "34 T" D; "3 AXLES" D; "38 T" D;

R12-Y4-EVd 78"x48"

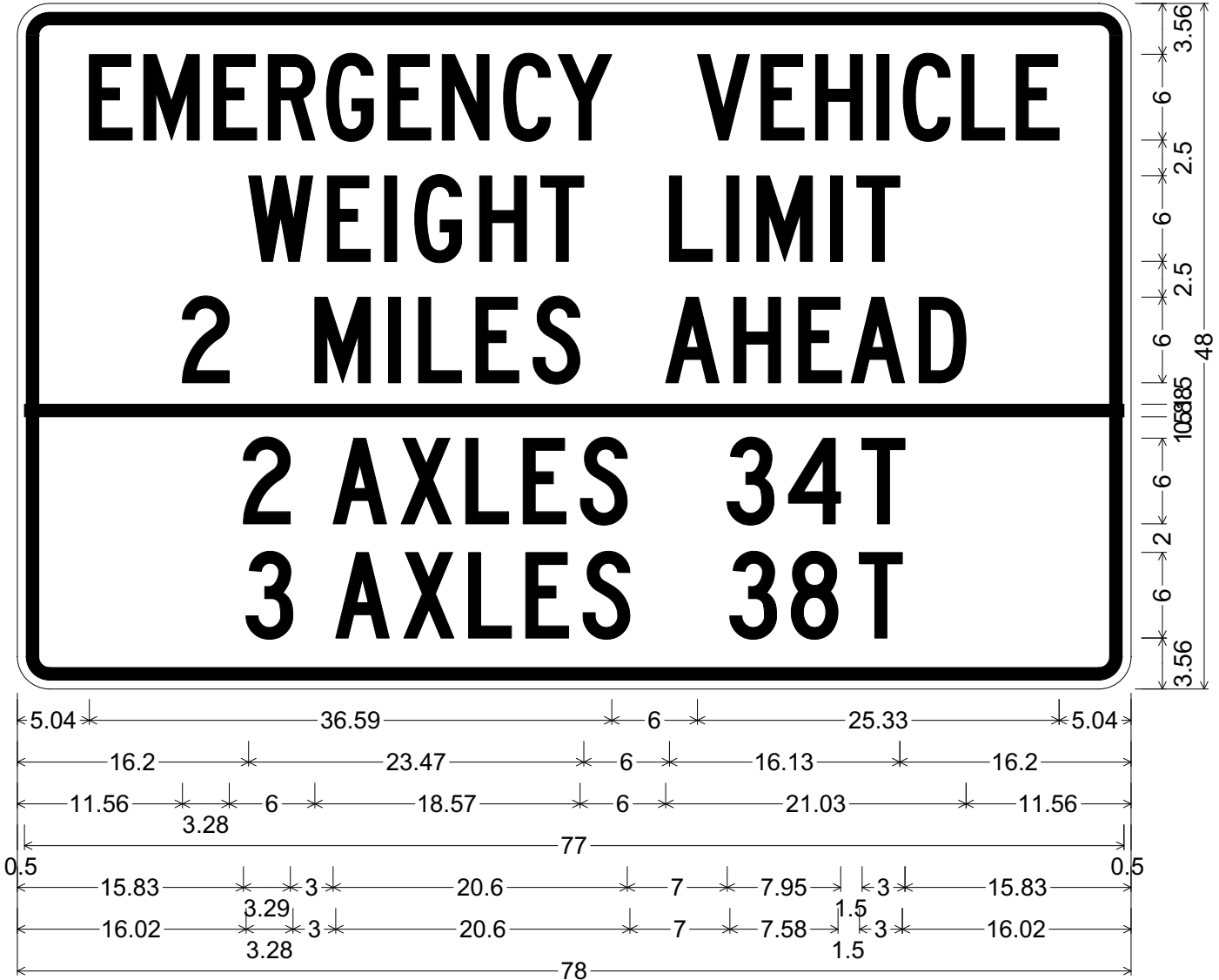

2.25" Radius, 0.88" Border, 0.63" Indent, Black on White;

"EMERGENCY VEHICLE" C 80% spacing; "WEIGHT LIMIT" C; "2 MILES AHEAD" C;

"2" C " " D "AXLES" C; "34" C " " D "T" C; "3" C " " D "AXLES" C; "38" C " " D "T" C;

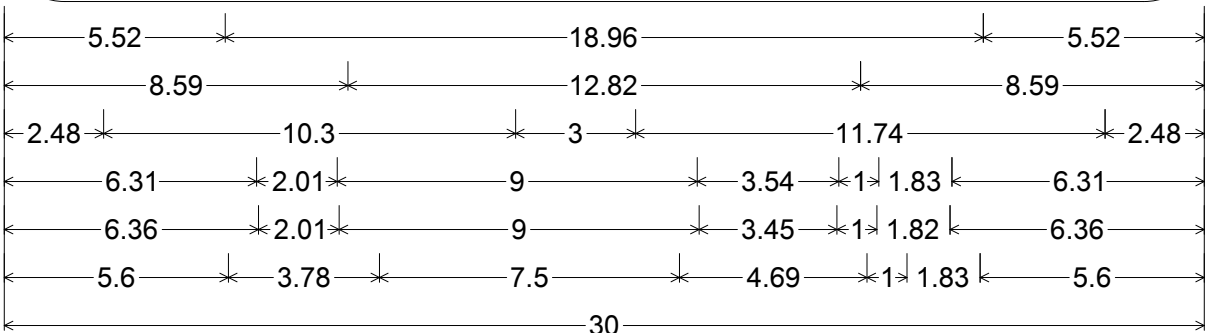
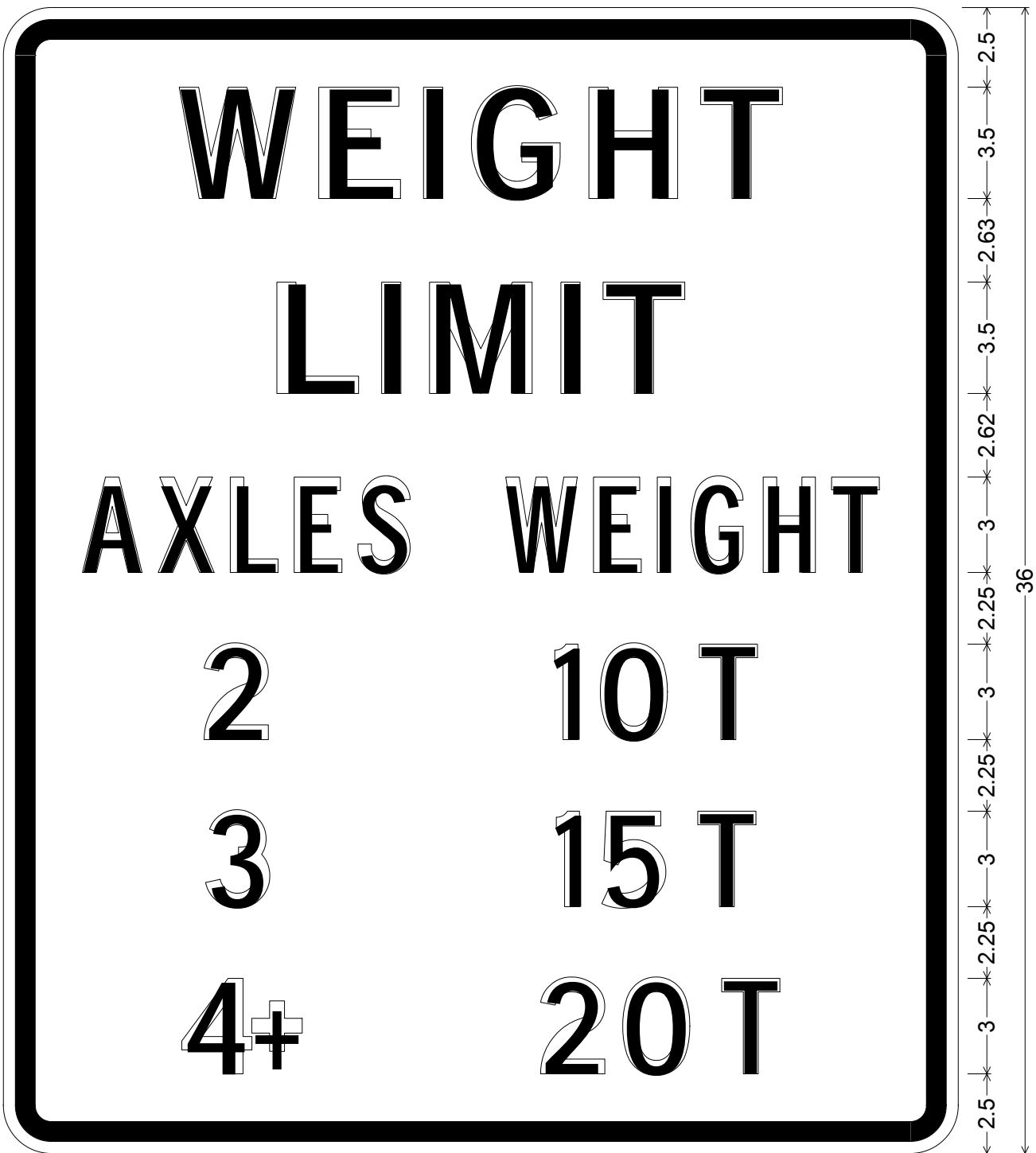

1.50" Radius, 0.63" Border, 0.38" Indent, Black on White;
 "WEIGHT" E; "LIMIT" E; "AXLES" C; "WEIGHT" C; "2" D; "10 T" D; "3" D; "15 T" D;
 "4+" D; "20 T" D;

R12-Y5 30"x36"

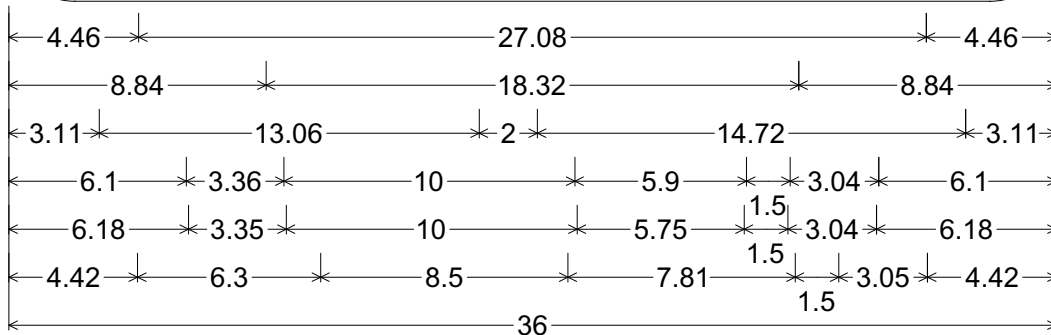
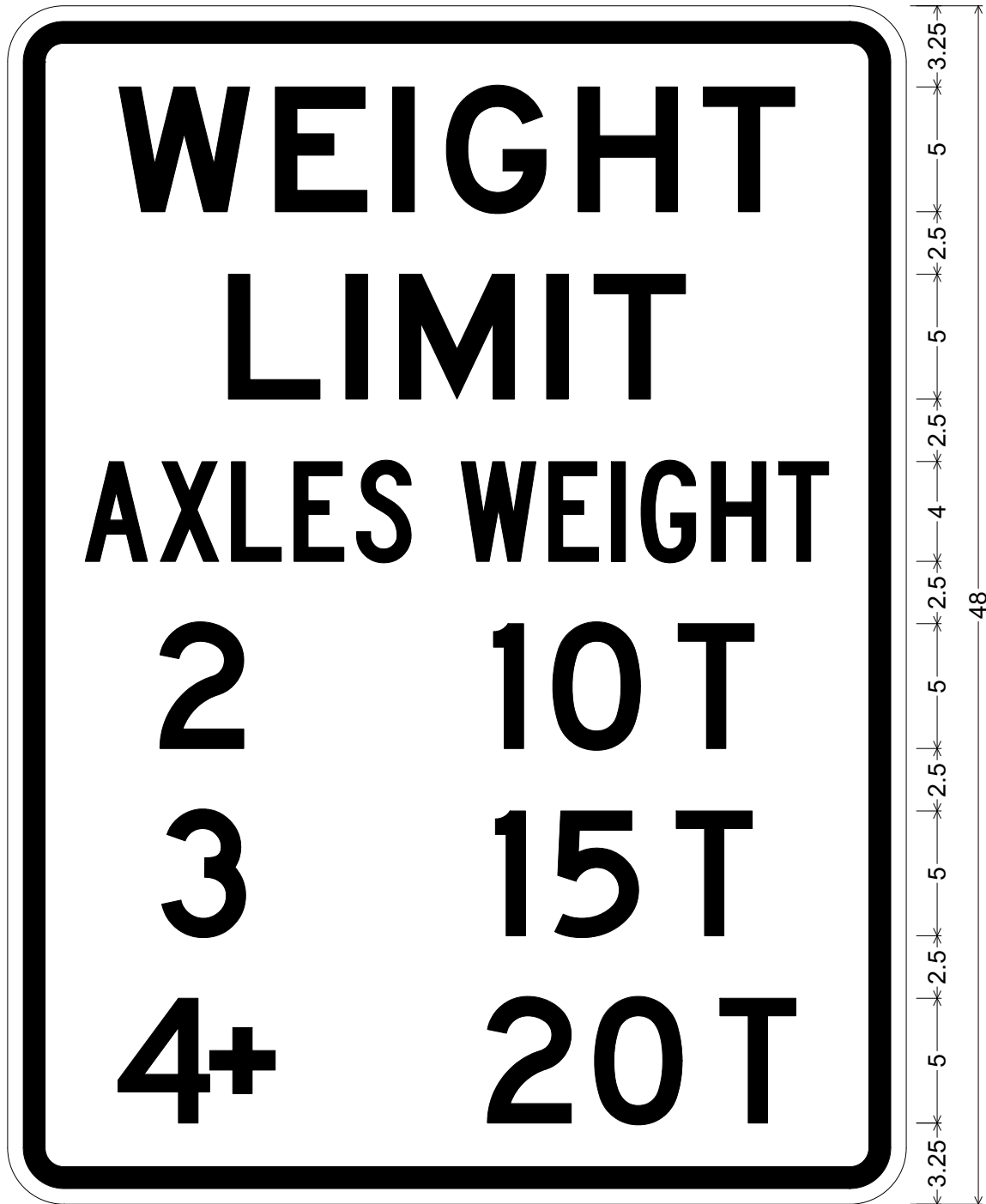

2.25" Radius, 0.88" Border, 0.63" Indent, Black on White;
 "WEIGHT" E; "LIMIT" E; "AXLES" C 75% spacing; "WEIGHT" C 75% spacing;
 "2" D; "10 T" D; "3" D; "15 T" D; "4+" D; "20 T" D;

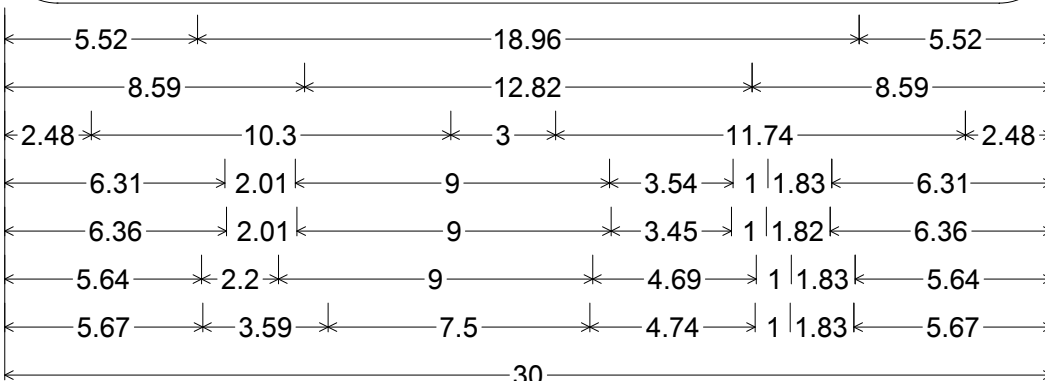
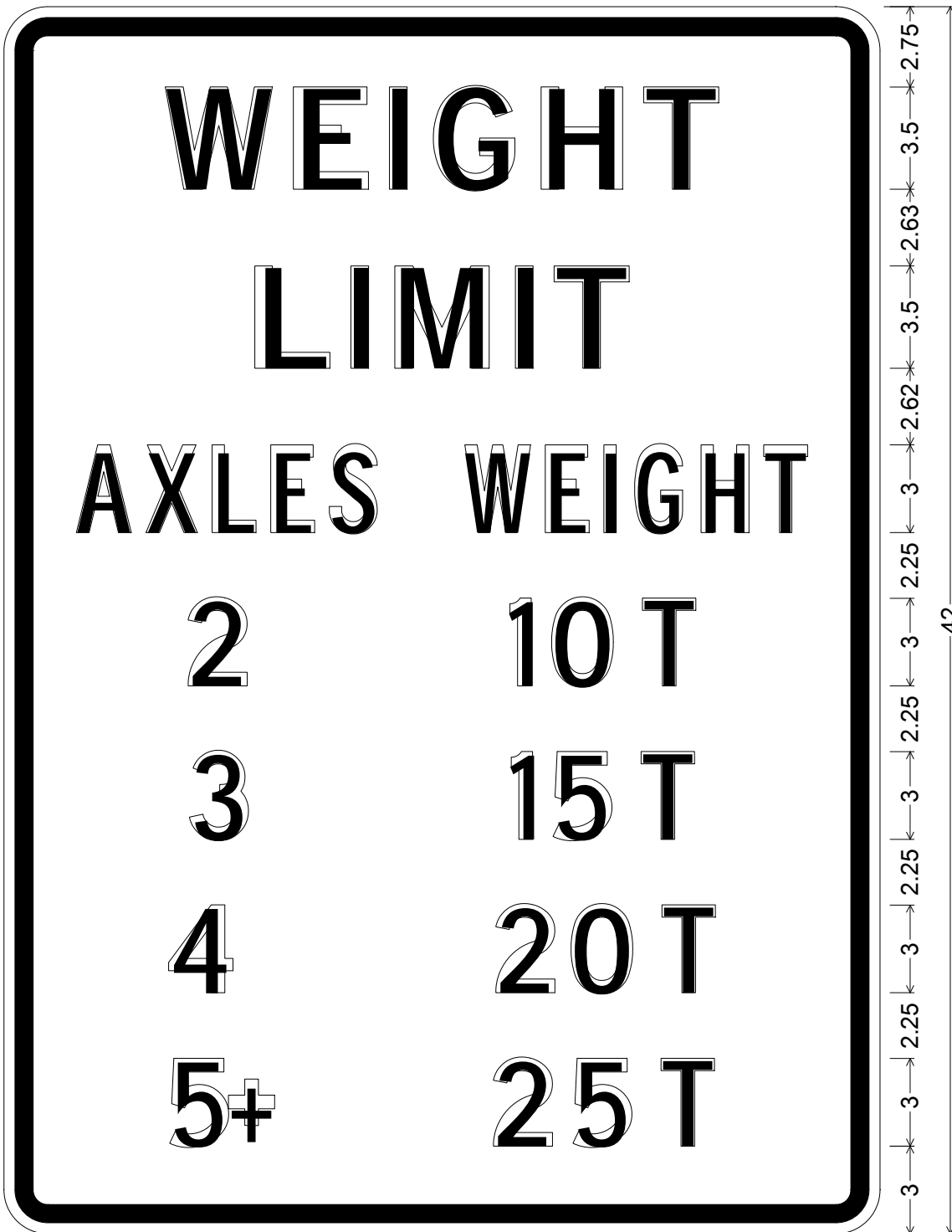

1.50" Radius, 0.63" Border, 0.38" Indent, Black on White;
 "WEIGHT" E; "LIMIT" E; "AXLES" C; "WEIGHT" C; "2" D; "10 T" D; "3" D; "15 T" D; "4" D; "20 T" D; "5+" D; "25 T" D; R12-Y5a 30"x42"

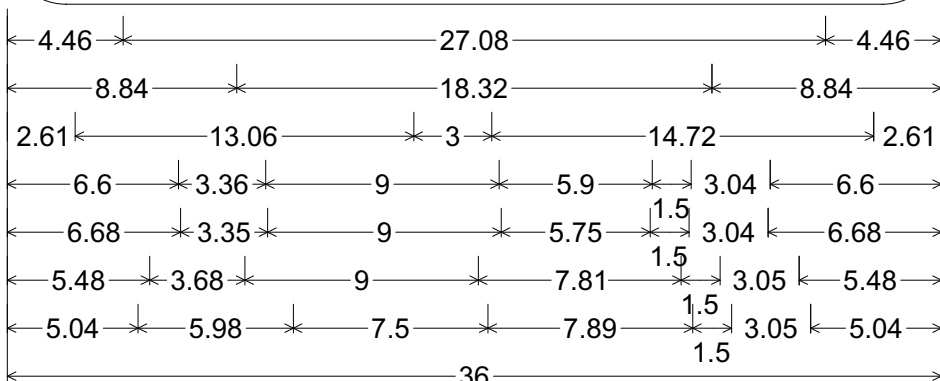
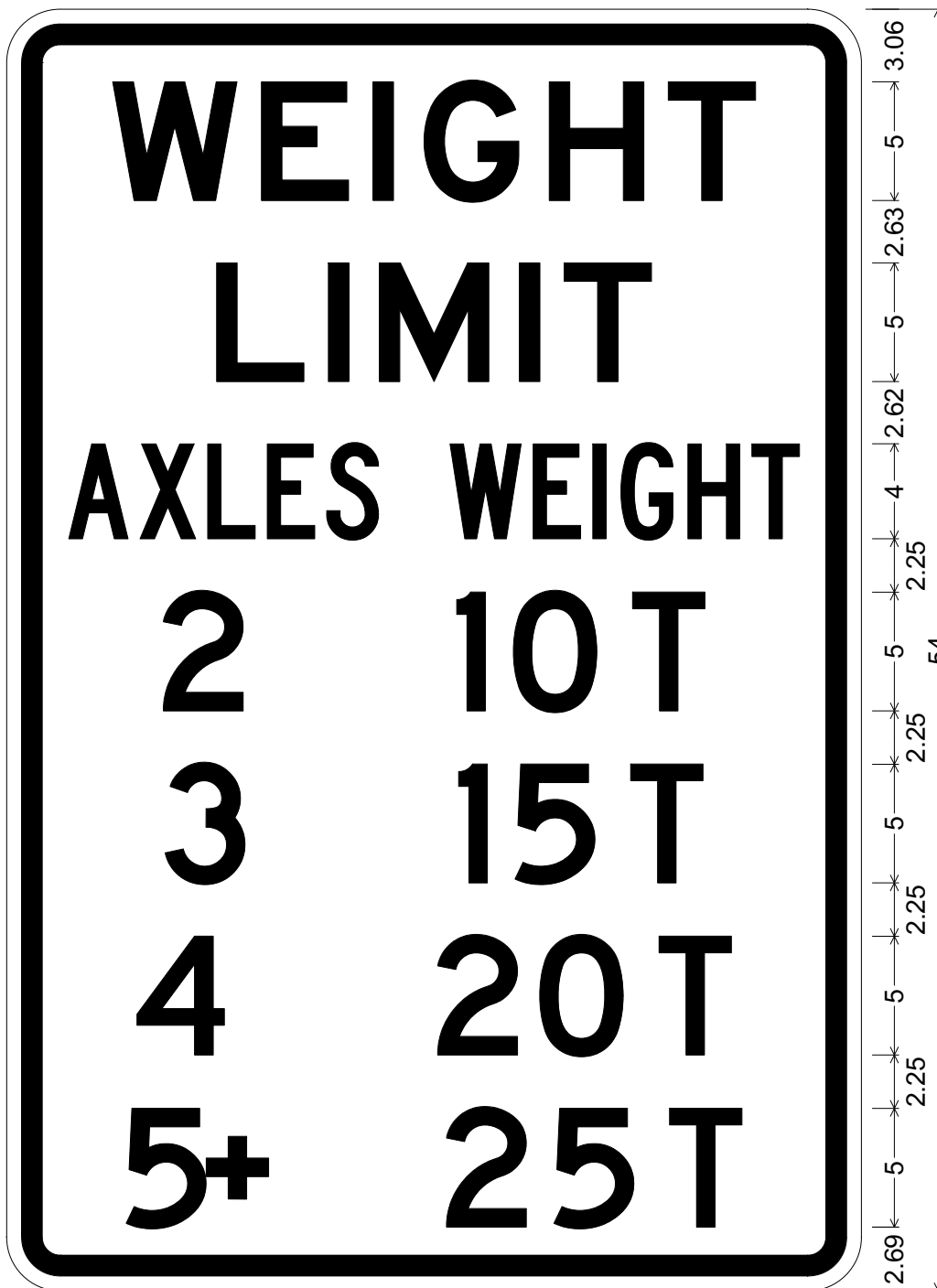

2.25" Radius, 0.88" Border, 0.63" Indent, Black on White;
 "WEIGHT" E; "LIMIT" E; "AXLES" C 75% spacing;
 "WEIGHT" C 75% spacing; "2" D; "10 T" D; "3" D; "15 T" D; "4" D;
 "20 T" D; "5+" D; "25 T" D;

R12-Y5a 36"x54"

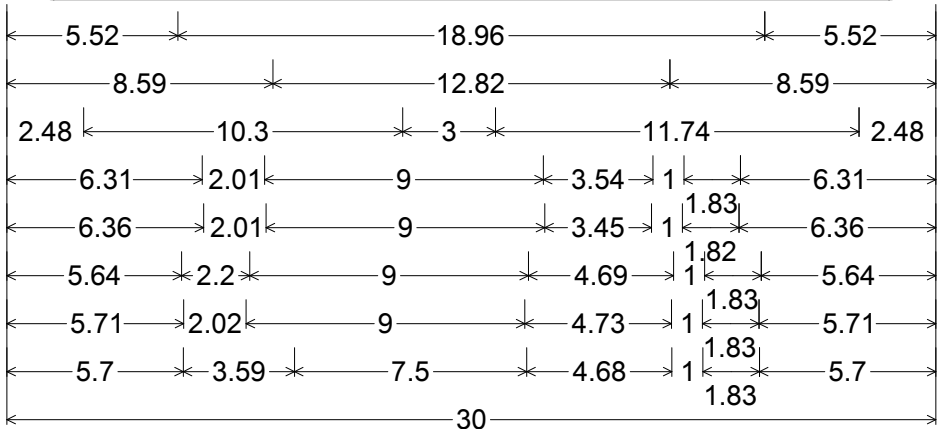
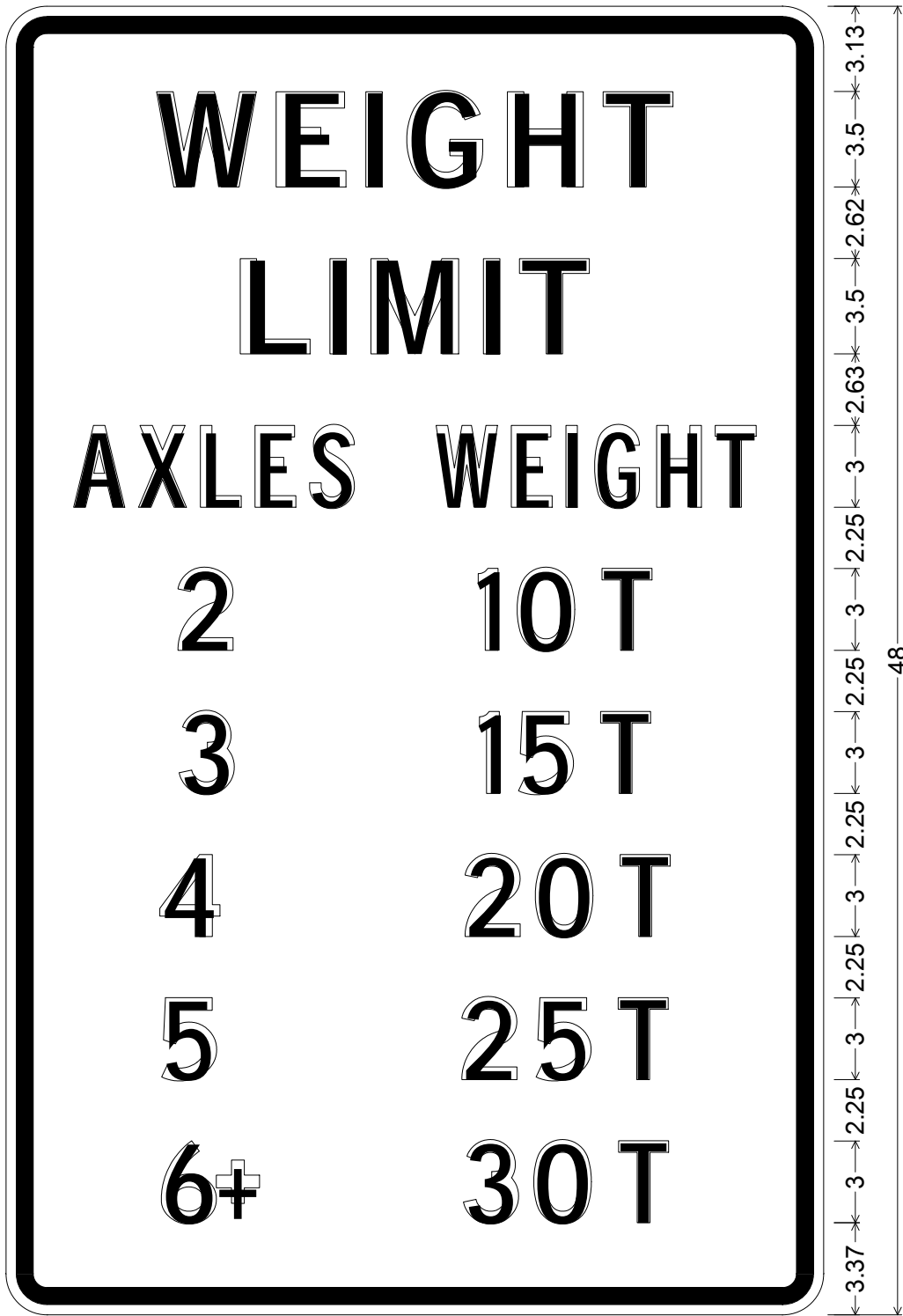

R12-Y5b 30"x48"

1.50" Radius, 0.63" Border, 0.38" Indent, Black on White;
 "WEIGHT" E; "LIMIT" E; "AXLES" C; "WEIGHT" C; "2" D; "10 T" D;
 "3" D; "15 T" D; "4" D; "20 T" D; "5" D; "25 T" D; "6+" D; "30 T" D;

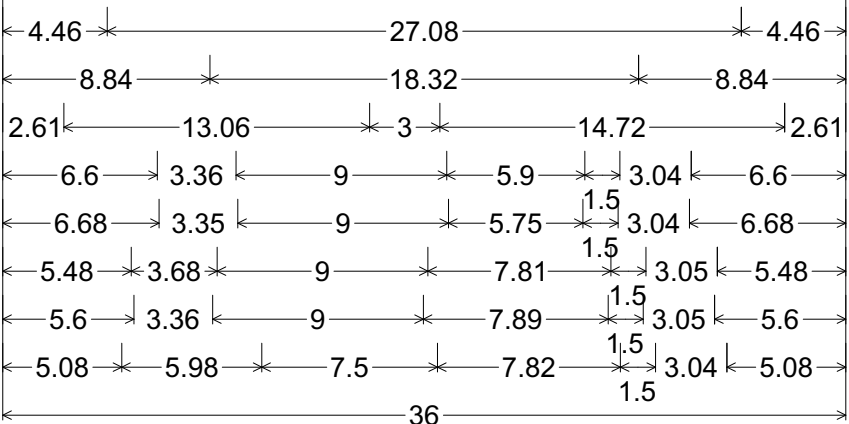
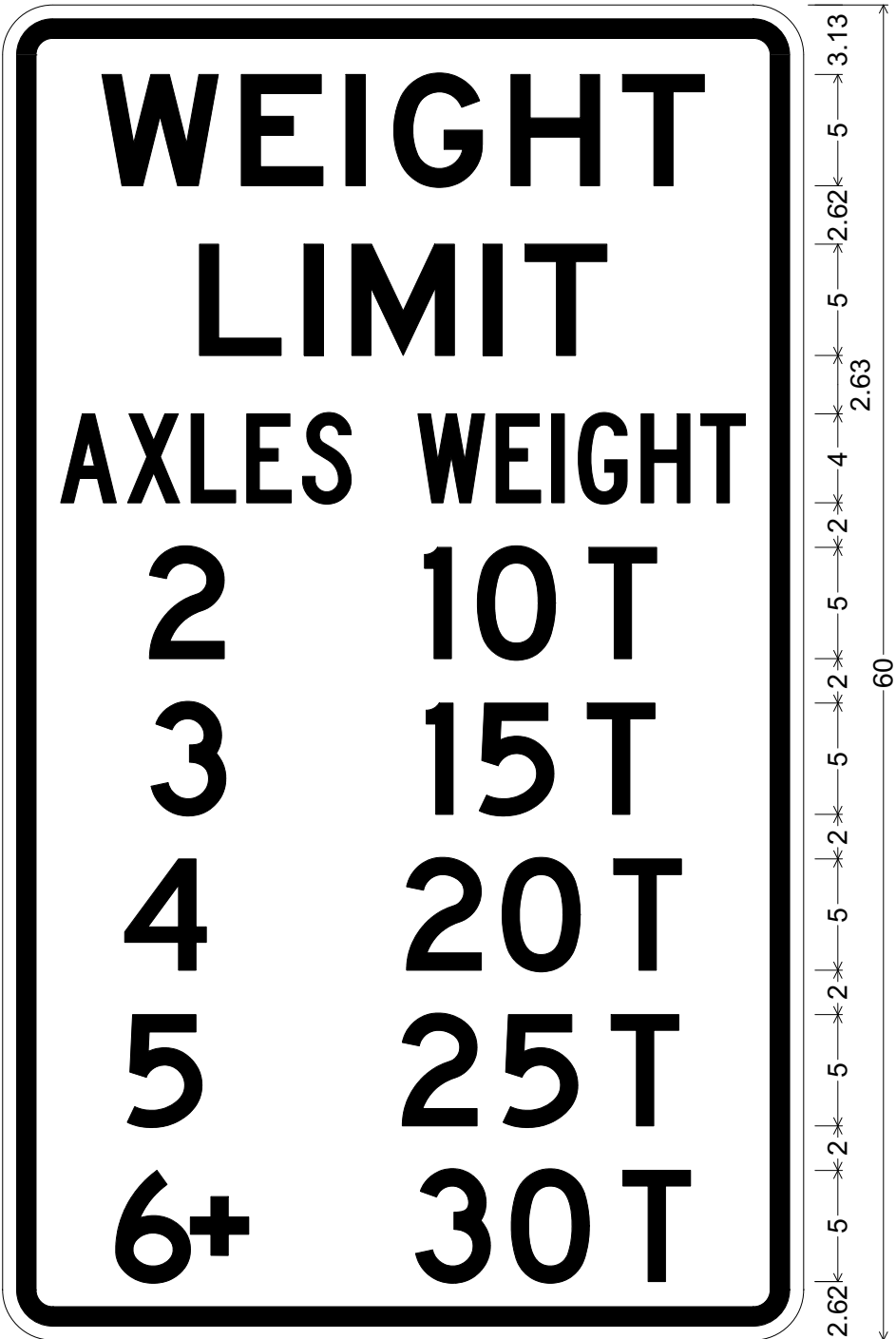

R12-Y5b 36"x60"

2.25" Radius, 0.88" Border, 0.63" Indent, Black on White;
 "WEIGHT" E; "LIMIT" E; "AXLES" C 75% spacing;
 "WEIGHT" C 75% spacing; "2" D; "10 T" D; "3" D; "15 T" D;

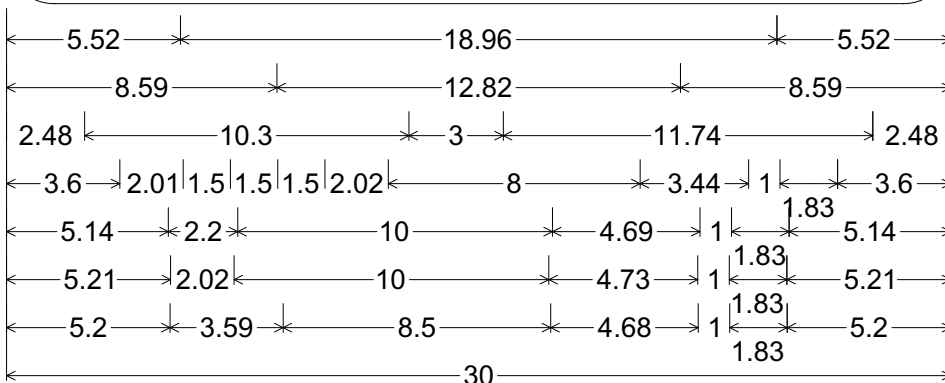
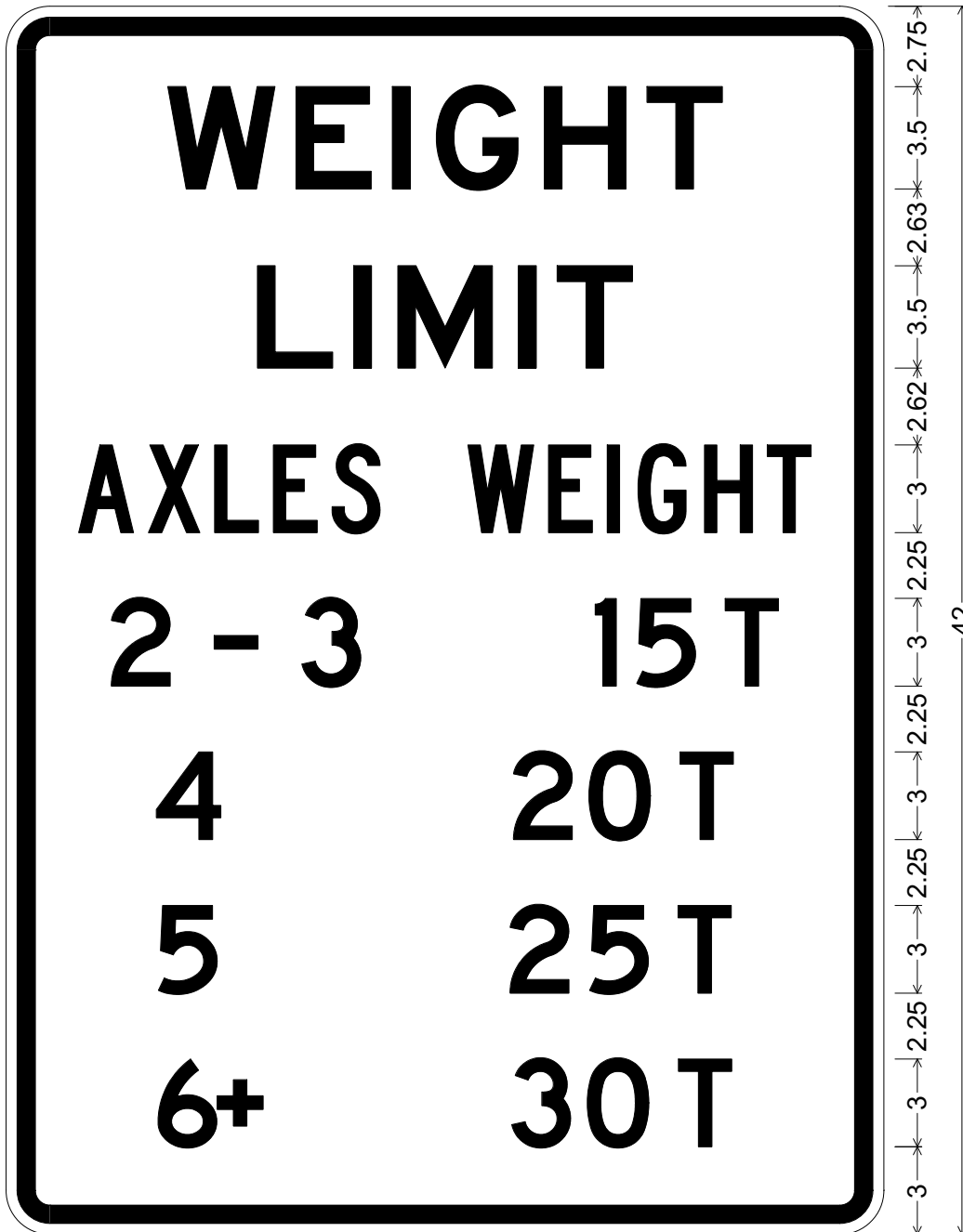

1.50" Radius, 0.63" Border, 0.38" Indent, Black on White;
 "WEIGHT" E; "LIMIT" E; "AXLES" C; "WEIGHT" C; "2 - 3" D; "15 T" D;
 "4" D; "20 T" D; "5" D; "25 T" D; "6+" D; "30 T" D;

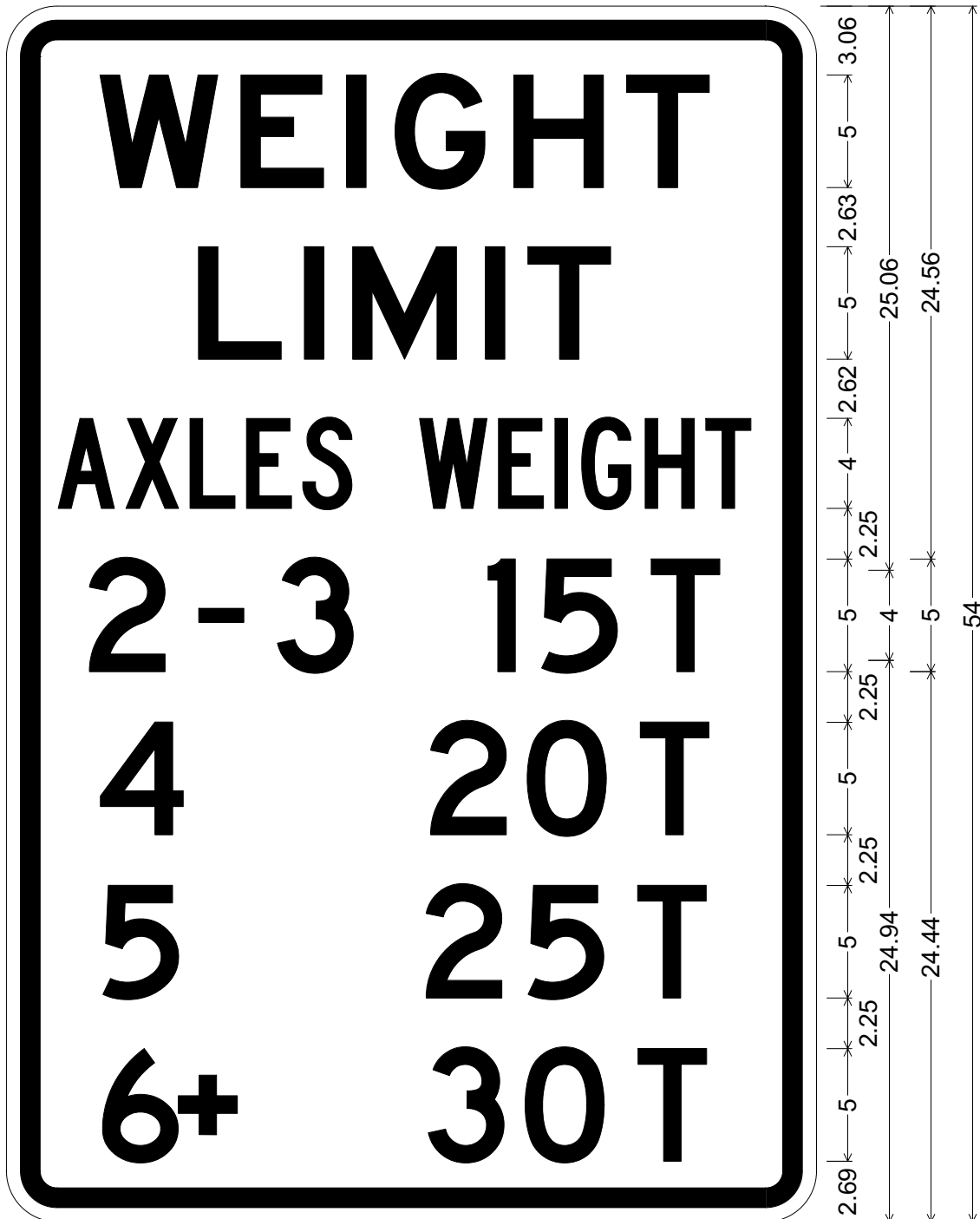

2.25" Radius, 0.88" Border, 0.63" Indent, Black on White;
 "WEIGHT" E; "LIMIT" E; "AXLES" C 75% spacing;
 "WEIGHT" C 75% spacing; "2 - 3" D; "15 T" D; "4" D; "20 T" D; "5" D;
 "25 T" D; "6+" D; "30 T" D;

INDOT BRIDGE INSPECTION MANUAL

PART 4

QA / QC

Table of Contents

4-1.0 INTRODUCTION.....3
4-1.01 Purpose.....3
4-1.02 Scope.....3
4-1.03 Definitions.....3
4-2.0 QUALITY CONTROL4
4-2.01 Inspection and Load Rating Teams.....4
4-2.02 Inspection Process.....4
4-2.03 Quality Control Reviewer (QCR).....4
4-2.04 Quality Control Office Review.....4
 4-2.04(01) Purpose and Scope.....4
 4-2.04(02) Quality Control Criteria.....5
 4-2.04(03) Sampling.....5
4-2.05 Quality Control Field Review.....5
 4-2.05(01) Purpose and Scope.....5
 4-2.05(02) Quality Control Criteria.....6
 4-2.05(03) Sampling.....6
4-2.06 Corrective Actions.....6
4-2.07 State Owned and Maintained Fracture Critical Bridges.....7
4-3.0 QUALITY ASSURANCE7
4-3.01 Quality Assurance.....7
4-3.02 Control Bridge or Training Workshop.....7
4-3.03 Independent Oversight.....8
 4-3.03(01) Independent Oversight Closeout.....8
4-3.04 Bridge File and Load Rating Review.....8
 4-3.04(01) Purpose and Scope.....8
 4-3.04(02) Bridge File Review.....8
 4-3.04(03) Load Rating Verification Review.....9
4-3.05 Corrective Actions.....9
4-4.0 DISQUALIFICATION & REQUALIFICATION9
4-4.01 Disqualification Process.....9
4-4.02 Disqualification Criteria.....10
4-4.03 Requalification Process.....11

4-1.0 INTRODUCTION

4-1.01 Purpose

Federal Regulation 23 CFR 650.313(g) requires that each state use systematic quality control and quality assurance procedures to maintain a high degree of accuracy and consistency in the State Bridge Inspection Program (SBIP). To meet this requirement, bridge owners shall implement the quality control and quality assurance measures described herein.

Quality control and quality assurance procedures shall include periodic field review of inspection teams, periodic bridge inspection refresher training, and independent review of inspection reports and computations.

4-1.02 Scope

This manual outlines the following items in the state quality control and quality assurance program:

- Bridge inspection training
- Quality control roles and review procedures
- Quality assurance roles and review procedures
- Maintenance of the bridge file
- Identification and resolution of data errors, omissions, and/or changes
- Disqualification and requalification processes

4-1.03 Definitions

- **Bridge Inspection Training:** Training that covers all aspects of bridge inspection and enables inspectors to relate conditions observed on a bridge to established criteria.
- **Critical Finding:** A structural or safety related deficiency that requires immediate follow-up inspection or action.
- **Inspecting Agency:** The organizational unit responsible for conducting or overseeing bridge inspection. The inspecting agency for a state-owned bridge is the appropriate District. The inspecting agency for a county, toll road, or other locally owned bridge is the Inspection Consultant.
- **Load Rating:** The determination of the live load-carrying capacity of a bridge using bridge plans and supplemented by information gathered from a field inspection.

- **Quality Assurance (QA):** The use of sampling and other measures to assure the adequacy of quality control procedures to verify or measure the quality of the inspection and load rating programs. Typically conducted from outside of the inspecting agency for the purpose of evaluating the quality of the program overall.
- **Quality Control (QC):** Procedures intended to maintain the quality of a bridge inspection and load rating at or above a specified level. Typically conducted from within an inspecting agency for the purpose of providing consistency within the inspecting agency, or from an external source when reviewing data for a specific district, county, toll road, or local agency.

4-2.0 QUALITY CONTROL

4-2.01 Inspection and Load Rating Teams

The qualifications and responsibilities for the individuals performing inspections and load ratings are discussed in Part 1-1.04(14).

4-2.02 Inspection Process

For information related to Local Public Agency (LPA) – Consultant Bridge Inspection Contracts please refer to the Local Public Agency Project Development Process Guidance Document which can be found on the INDOT website.

4-2.03 Quality Control Reviewer (QCR)

A designated quality control reviewer must have team leader credentials. For firms without an active second Inspection Team Leader, another consulting firm with a qualified Inspection Team Leader will need to act as the quality control reviewer.

The QCR:

- Shall not be a member of the original inspection team to ensure an independent review.
- Shall have knowledge of required procedures and practices, as well as federal or state requirements.

4-2.04 Quality Control Office Review

4-2.04(01) Purpose and Scope

The primary goal of the Quality Control Office Review is to ensure the accuracy and consistency within an Inspecting Agency, and completeness of the inspection data and all required reports. This should include reviewing the data and reports to make certain that they meet both federal and state requirements. Prior to the Quality Control Office Review, the Inspection Team Leader should run

all data checks and make all required corrections.

4-2.04(02) Quality Control Criteria

This review by the QCR shall include the following:

- The quality control review will follow the NBIP File Review Checklist and forms that can be found in appendix of part 2.
- The metrics to be assessed in the review are metric 12, 13, 14, 15, 16, 17, 18, 22, and 23.
- Guidance for evaluation criteria and metric commentary may be found in the Federal Highway document *Metrics for the Oversight of the National Bridge Inspection Program*.
- The Federal Highway document may be found at:
<http://www.fhwa.dot.gov/bridge/nbip/metrics.pdf>.

4-2.04(03) Sampling

The Quality Control Office Review shall be performed on bridges selected from a group that meet any of the following criteria if available:

- A rating of 4 or less for Items 58, 59, 60, or 62
- A rating that changed by two or more for Items 58, 59, 60, or 62
- A rating of 3 or less for Item 113A
- Posted

For the purposes of quality control, each team leader will ensure that two bridge files are reviewed per year. On or before June 1st and November 1st of each year a report will be available upon request. The quality control file will include the quality control office review forms filled out for the reporting period. The reports will remain in the file for three years.

4-2.05 Quality Control Field Review

4-2.05(01) Purpose and Scope

The primary goal of the Quality Control Field Review is to ensure consistency within an Inspecting Agency of the field inspection and data collection. The review will evaluate the consistency and accuracy of component ratings, inventory items, and adequacy of photographic documentation, notes, and recommended maintenance actions.

A Quality Control Field Review involves a field inspection of a bridge, including verification of data incorporated in the inspection report. The field inspection should take place within twelve months of the original inspection to ensure that conditions have not changed significantly.

4-2.05(02) Quality Control Criteria

This review should include the following:

1. Perform an independent field review.
2. The quality control review will follow the NBIP File Review Checklist and forms that can be found in appendix of Part 2.
3. The metrics to be assessed in the review are metric 12, 13, 14, 15, 16, 17, 18, 22, and 23.
4. Guidance for evaluation criteria and metric commentary may be found in the Federal Highway document Metrics for the Oversight of the National Bridge Inspection Program.
5. The Federal Highway document may be found at: <http://www.fhwa.dot.gov/bridge/nbip/metrics.pdf>.

For the purposes of quality control, each team leader will ensure that one bridge file is field reviewed per year. On or before November 1st of each year a report will be available upon request. The quality control file will include the quality control review forms filled out for the reporting period. The reports will remain in the file for three years.

4-2.05(03) Sampling

The Quality Control Field Review shall be performed on bridges selected from a group that meet any of the following criteria if available:

- A rating of 4 or less for Items 58, 59, 60, or 62
- A rating that changed by two or more for Items 58, 59, 60, or 62
- A rating of 3 or less for Item 113A
- Posted
- A Critical Finding has been reported.

For the purposes of quality control, each team leader will ensure that one bridge is field reviewed per year. On or before November 1st of each year, a report will be available upon request. The quality control file will include the quality control field review forms filled out for the reporting period. The reports will remain in the file for three years.

4-2.06 Corrective Actions

The team leader is responsible for any corrective action that is needed for an existing bridge file under review. The office and field reviews are intended to be an instructive process where errors and omissions can be found and eliminated. The only repercussion to the quality control reviews would be the lack of quality of the review or if corrections were recommended but not completed or explained by the team leader. The INDOT Data Manager (Asst Bridge Inspection Mgr) will review

the files in question.

4-2.07 State Owned and Maintained Fracture Critical Bridges

INDOT shall perform a Quality Control Review on 100% of all Fracture Critical Inspections conducted each year, on all State Owned and Maintained Fracture Critical Bridges. This shall consist of the Team Leader in charge of the inspection submitting the completed inspection report to another Team Leader at INDOT who was not involved with the inspection. This Team Leader is to review the report and attachments for completeness, accuracy, and adhering to the requirements in the INDOT Bridge Inspection Manual, primarily those outlined in Part 5 of the Manual, (Fatigue and Fracture Critical Inspections).

4-3.0 QUALITY ASSURANCE

4-3.01 Quality Assurance

The INDOT Bridge Inspection Unit has revised the procedures for quality assurance, incorporating two quality assurance methods.

The first method will incorporate a procedure for inspecting a control bridge or bridges. The control bridge will be evaluated by a designated team of highly qualified bridge inspectors which will establish the target values for the control bridge. The team leaders will then be assigned a time to inspect the control bridge or bridges.

The second quality procedure will be independent oversight. In this method, a third party is enlisted to re-inspect a bridge previously inspected by a team leader. The independent reviewer will then compare the inspections.

These two procedures will be further developed in the next two section of the manual.

4-3.02 Control Bridge or Training Workshop

At the discretion of the Bridge Inspection Program Manager (Asst Bridge Inspection Mgr), a test bridge or training workshop will be held annually. The control bridge will be evaluated by a designated team of inspectors. The team members will be highly qualified and will independently determine the rating values for the bridge. The team members will also identify any deficiencies and critical findings. Any required notes or explanation of findings will be noted in the inspection. The inspection team will then meet and determine the values and findings to assign to the structure.

All team leaders will inspect the control bridge. The directions and expectations will be clearly defined well in advance of the date selected for the control bridge inspection. The exact testing procedures and review of results may vary for testing sessions, but all expectations will be outlined in the testing instructions.

BRIDGE INSPECTION MANUAL

Part 4: QA / QC

All team members are required to inspect the control bridge. Failure to inspect the control bridge will be cause for review of the team member's credentials. This review may include a review of bridge files submitted into BIAS and/or the basis for an independent oversight review. A team member missing two consecutive control bridge inspections shall have their Bridge Inspection qualifications reviewed by the Program Manager and shall be considered for a Quality Assurance Review.

Team members performing poorly on the control inspection will be subject to corrective actions.

If the Bridge Inspection Program Manager (Asst Bridge Inspection Mgr) elects to hold an annual training workshop in lieu of a test bridge, the training workshop attendance is required and may include testing.

4-3.03 Independent Oversight

As a minimum, 24 bridge files will be selected annually for independent oversight. These structures in part will be selected from the list of team leaders that did not participate in the control bridge testing or workshop training. The remaining portion of the selected files will be selected at random.

For the selected bridge files, a third party will re-inspect the bridge. This inspection will be a complete inspection which will generate a comparison of the original inspection. This will give a very accurate comparison for consistency and accuracy.

4-3.03(01) Independent Oversight Closeout

For Quality Assurance Independent Oversight Reviews, after the inspections have been concluded, the reviewer will generate a Quality Assurance Report summarizing the findings. The findings shall be discussed with the State Program Manager and submitted to all Inspection Team Leaders involved in the inspections. An annual report will be generated which summarizes the findings.

4-3.04 Bridge File and Load Rating Review

4-3.04(01) Purpose and Scope

The primary goal of the Quality Assurance Bridge File Review is to ensure the completeness of the individual bridge files. The Quality Assurance Bridge File Review ensures that the QC efforts are effective across Inspecting Agencies, resulting in overall quality in the State Bridge Inspection Program. Bridge files should be reviewed to ensure that the bridges are properly load-rated and documented and that they contain any other required/available bridge documentation.

4-3.04(02) Bridge File Review

The INDOT Data Base Manager (Asst Bridge Inspection Mgr) will select a minimum of 10 bridge files per quarter for quality control review. One half of those files will be selected by searching files for known or suspected inaccuracies. The remaining files will be selected at random.

The bridge files will be reviewed for accuracy and completeness. The items checked for the bridge file will be as outlined in the *AASHTO Manual for Bridge Evaluation*, Section 2.

The findings of the quarterly review will be submitted to the INDOT Bridge Inspection Program Manager (Asst Bridge Inspection Mgr).

4-3.04(03) Load Rating Verification Review

The INDOT Bridge Load Rating Engineer will select a minimum of 10 bridge files per quarter for quality control review. These files may have been selected for a bridge file review where the load rating section of the file was in question or the files may be selected at random.

The file will be reviewed for accuracy and completeness. The file must contain the summary sheet from the load rating and all supporting computations which must include a clear statement of all assumptions used in calculating the load rating. For computer modeling, an input data file will be included in the file.

The findings of the quarterly review will be submitted to the INDOT Bridge Inspection Program Manager.

4-3.05 Corrective Actions

Data errors, omissions, and/or changes can occur during the inspection and inventory process, as well as during the quality assurance process. The identification and resolution of these items shall be done in an expedited manner. Notification of the issue shall occur immediately to the appropriate INDOT inspector or Inspection Consultant. The issue will be discussed in-depth. Any revision to the report shall be documented and submitted to the State Program Manager. Once reviewed and accepted by the State Program Manager, the corrected information shall be submitted to the Inspecting Agency for their files or further action.

4-4.0 DISQUALIFICATION & REQUALIFICATION

4-4.01 Disqualification Process

When Quality Assurance Reviews indicate that an Inspection Team Leader and/or an Inspecting Agency continue to make the same or similar mistakes or omissions, the State Program Manager shall implement disqualification procedures as follows:

1. Upon receiving INDOT's Quality Assurance Report, the team leader shall address the findings of the report and take steps to correct the problems to ensure they will not be

repeated in the future.

2. The Inspection Team Leader will be placed on probation and two inspected bridges will be reviewed within the next inspection cycle. This review will be conducted by a team selected by the Program Manager.
3. If the inspections are found to be of poor quality, the team leader will be disqualified.

INDOT reserves the right to disqualify immediately and indefinitely if gross negligence, misconduct, and/or major omissions are found. These errors may adversely affect the safety of the public and/or the capacity of the bridge.

4-4.02 Disqualification Criteria

The criterion for disqualification of an Inspecting Agency or Inspection Team Leader includes, but is not limited to, the following:

1. Lack of proper follow-up with the bridge owner for Critical Deficiencies, such as broken load-carrying members, critical scour at foundations, vehicular impacts which could adversely affect load-carrying members, or bridges requiring closure.
2. Lack of follow-up with the bridge owner for correcting load-posting deficiencies
3. Failure to satisfy the required testing for quality control.
4. Failure to correct findings from Quality Control or Quality Assurance Reviews, including recurring unacceptable scores.
5. Recurring miscoded National Bridge Inventory (NBI) items
6. Recurring miscoded critical rating items such as condition states
7. Recurring condition rating deviations of more than one above or below an independent condition review
8. Failure to submit completed inspection data and/or corrections in a timely manner.
9. Failure to maintain the bridge file to meet minimum requirements.
10. Failure to maintain or update any required Plans of Action.
11. Failure to inspect the bridges within the required frequency (unless the notice to proceed was given too late to make this possible)
12. Dishonest or unethical behavior that adversely affects the inspection results.

INDOT has the final authority to carry out this disqualification process. Inspecting Agencies must accept these procedures as part of any bridge inspection agreement before they will be allowed to perform any bridge inspections.

4-4.03 Requalification Process

1. A disqualified Inspection Team Leader and/or Inspection Agency may be re-qualified after the two-year period if they explain in writing how they will correct their deficiencies. Upon approval by INDOT, the Inspection Team Leader or Inspecting Agency shall be placed back on the qualified list and under probation for 12 months.
2. A disqualified Inspection Team Leader may also be re-qualified following the two-year disqualification period after he/she has retaken the Safety Inspection of In-Service Bridges (FHWA-NHI-130055) class and successfully completed.
3. Henceforth, prospective Inspection Team Leaders taking the Safety Inspection of In-Service Bridges (FHWA-NHI-130055) class must attend the entire course.

INDOT BRIDGE INSPECTION MANUAL

PART 5

FATIGUE & FRACTURE CRITICAL INSPECTIONS

BRIDGE INSPECTION MANUAL

PART 5: BRIDGE INSPECTION

Table of Contents

| | |
|---|-----------|
| LIST OF FIGURES... | 3 |
| 5-5.0 FATIGUE AND FRACTURE CRITICAL INSPECTIONS | 4 |
| 5-5.01 THE FRACTURE CRITICAL INSPECTION | 4 |
| 5-5.01(01) <i>Classification of Fracture Critical Members</i> | 4 |
| 5-5.01(02) <i>Inspector Qualification</i> | 5 |
| 5-5.01(03) <i>Inspection Interval</i> | 6 |
| 5-5.01(04) <i>Inspection Preparation</i> | 6 |
| 5-5.01(05) <i>Field Inspection</i> | 6 |
| 5-5.01(06) <i>Field Inspection Reporting</i> | 9 |
| FIGURES | 10 |

BRIDGE INSPECTION MANUAL

PART 5: BRIDGE INSPECTION

LIST OF FIGURES

| <u>FIGURE</u> | <u>TITLE</u> |
|---------------|---|
| Figure 5:5-1: | Fracture Critical Truss Connection |
| Figure 5:5-2: | Fracture Critical Floor Beam Connection |
| Figure 5:5-3: | Fracture Critical Connection at Through Girder |
| Figure 5:5-4: | Example Inspection Plan Sketch (Truss) |
| Figure 5:5-5: | Example Inspection Plan Sketches (Through Girder) |
| Figure 5:5-6: | Typical Pin and Eyebar Details |
| Figure 5:5-7: | Forged Eyebar with Extensive Section Loss |

BRIDGE INSPECTION MANUAL

PART 5: BRIDGE INSPECTION

5-5.0 FATIGUE AND FRACTURE CRITICAL INSPECTIONS

5-5.01 The Fracture Critical Inspection

Proper identification, classification, inspection, and reporting of all fracture critical bridges and the required close-up, arms-reach inspection of the fracture critical members, components, and connections are crucial to the longevity of Indiana's bridges and the safety of the public. Uniformity in reporting will allow the inspectors to monitor any problems accurately and closely throughout the life of the structure. Detailed and accurate reporting also allows the bridge owner to maintain a comprehensive history of the service life of each bridge containing fracture critical members, components, and connections, and all corrective actions done for the bridge before major problems evolve.

5-5.01(01) Classification of Fracture Critical Members

The FHWA defines a fracture critical member as a steel member either fully in tension or with a tension element, whose failure would probably cause either a portion of, or the entire, bridge to collapse. A fracture critical bridge is one that contains one or more non-load path redundant steel tension member, component, or connection. The FHWA presents two criteria for identifying a fracture critical bridge:

1. The bridge must have one or more steel members, components, or connections in tension. These loading conditions may include tensile forces and flexure. Load analysis may indicate that some members experience a stress reversal (varies from tension to compression) under various loads. Such members shall be included under these criteria.
2. There must be no load path redundancy of the bridge, in which no other structural elements can carry the load if a main load-carrying member fails. For a bridge to be defined as non-load path redundant, it must have two or less load paths.

Some bridge types that may be considered fracture critical include, but are not limited to, the following types:

1. Truss bridges (such as deck, through, and pony trusses) containing two main load-carrying members
2. Through girder bridges
3. Two-girder bridges
4. Tied arch bridges
5. Box girders
6. Cable-stayed bridges
7. Suspension bridges

BRIDGE INSPECTION MANUAL

PART 5: BRIDGE INSPECTION

8. Steel rigid frame bridges
9. Bridges containing steel cross-girders or steel pier caps

See Appendix 5A for examples of fracture critical bridges, components, bending diagrams, typical crack locations, and typical pin-and-hanger parts.

Timber covered bridges (trusses) with steel vertical tension hangers shall have Critical Feature Inspection Item 92A coded “N” unless a structural analysis determines these hangers as primary fracture critical members. Otherwise, they are a non-fracture-critical secondary member.

Once a bridge is designated as fracture critical, each individual member and connection determined by structural analysis as a fracture critical member, component, or connection must be identified for the inspection. Any attachment connected to the tension area of a fracture critical member and having a length in the direction of the tension stress greater than four inches shall be considered part of the tension component and, therefore, shall be considered fracture critical. For definition purposes and uniformity in reporting, the portions of the fracture critical member within a minimum of 12 inches of the entire connection (gusset plates, connection plates, etc.) shall be considered a fracture critical **connection**, whereas the portion of the tension member beyond the 12-inch window shall be considered a fracture critical **member**. See Figures [5:5-1](#), [5:5-2](#) and [5:5-3](#) for examples of this definition. The Inspection Team Leader shall use sound judgment to expand the minimum 12-inch criteria to include additional fatigue details and consider the scale of the bridge and associated members. Floor beam connections, lateral bracing connections, bearings, gusset plates, connection angles, pins, hangers, etc. are all typically considered a part of the fracture critical connection.

In the event the original design plans of a fracture critical bridge clearly indicate that a tension member is not fracture critical due to internal redundancies within the bridge, these members will still require a detailed inspection as part of the overall Fracture Critical Inspection. These tension members may only be omitted from the Fracture Critical Inspection if permission is given by both the owner and the State Program Manager.

5-5.01(02) Inspector Qualification

All Inspection Team Leaders for fracture critical bridges must:

1. Meet requirements in Part 1, Chapter 2
2. Possess adequate knowledge and understanding of how a fracture critical bridge functions, and where possible defects may occur
3. Possess suitable knowledge of the function of the specific bridge undergoing the inspection and, subsequently, the more complex bridges will warrant more knowledgeable,

BRIDGE INSPECTION MANUAL

PART 5: BRIDGE INSPECTION

experienced inspectors; knowledge includes the understanding and ability to perform testing or recommend advanced testing procedures at problem areas; must be current on issues with the type of bridges being inspected

4. Physical ability to provide a hands-on inspection of all fracture critical members and their appurtenant connections in the individual bridge

5-5.01(03) Inspection Interval

Fracture Critical Inspections shall be performed at a regular interval not to exceed 24 months. If necessary, the inspection interval may be reduced.

5-5.01(04) Inspection Preparation

The fracture critical Work Plan and Hazard Analysis must be developed and/or reviewed and updated prior to performing a Fracture Critical Inspection. This inspection work plan plays a crucial role in assisting all current and future inspectors at the bridge, and serves as an important first step in performing a thorough and complete investigation of all fracture critical members, while identifying necessary means, methods, and equipment required to perform this inspection. This inspection work plan is a required element for every fracture critical inspection report. These minimum requirements must be met for acceptance of the report by the Indiana Department of Transportation (INDOT). A Fracture Critical Inspection Notes and Report template is included in Appendix 5B of this manual. A Fracture Critical Work Plan and Hazard Analysis template is included in Appendix 5C.

Other items that should be reviewed and made available to the inspector, if available, prior to the inspection include the following:

1. Existing bridge plans and any repair/rehabilitation plans
2. Historical data and maintenance history of the bridge
3. Prior load ratings or a preliminary load rating (invaluable in determining fracture critical members)
4. Prior inspection reports

Note: Panel points are typically labeled beginning from South to North or from West to East in [Figure 5:5-4](#).

5-5.01(05) Field Inspection

The National Bridge Inspection Standard requires a hands-on inspection of all fracture critical

BRIDGE INSPECTION MANUAL

PART 5: BRIDGE INSPECTION

members, components, and connections. Hands-on is defined as being within arm's reach (i.e. two feet) of these components. The hands-on inspection requirement warrants the utilization of ladders, man lifts, climbing, and under-bridge vehicles to inspect all fracture critical members, components, and connections. Cracks and other deficiencies cannot be adequately located and inspected with the utilization of binoculars or outside of the inspector's reach from the member.

Primary compression members, floor beams, and secondary members such as lateral bracing, portal bracing, etc. are not considered fracture critical. These items require inspection and reporting during the Routine Inspection cycle. However, special consideration should be given to ensure that all primary and secondary members are inspected during the Routine or Fracture Critical Inspection so that no members are missed during the entire inspection cycle. At a minimum, the Inspection Team Leader should perform a brief walkthrough of all secondary and non-fracture critical primary members during the Fracture Critical Inspection as a simple means to ensure all members have been inspected. When expensive equipment such as an under-bridge vehicle or man lift is utilized during the Fracture Critical Inspection, the Inspection Team Leader should strongly consider and plan to utilize this equipment for the inspection of any difficult-to-inspect, non-fracture critical members or problem areas on the bridge.

It is imperative that the inspector adequately identify and inspect each fracture critical member and fatigue detail. Inspection for fatigue cracks in welded bridges should be performed at, but not limited to, the following locations:

For out-of-plane distortion in welded bridges, inspect the following locations if present:

1. Girder webs at floor beam and diaphragm connections
2. Ends of diaphragm connection plates in girder bridges
3. Box girder webs at diaphragms
4. Lateral bracing gusset plates on girder webs at floor beam connections
5. Floor beam and cantilever bracket connections to girders
6. Pin-connected hanger plates and fixed-pin plates

For main members in welded bridges, inspect the following locations, if present:

1. Ends of welded cover plates
2. Groove welds in flange plates
3. Butt welds in longitudinal stiffeners
4. Web plates with cut-outs and filler welds
5. Intersecting groove welds
6. Welded repairs and reinforcement

BRIDGE INSPECTION MANUAL

PART 5: BRIDGE INSPECTION

7. Back-up bar splices
8. Other stress risers

For connections and attachments in welded bridges, inspect the following locations, if present:

1. Cut short flanges
2. Coped beam ends
3. Blocked flange plates
4. Welded rigid connections of cross-girders at bents
5. Welded flange attachments
6. Intersecting welds at gusset plates and diaphragms

In general, the locations where fatigue cracks develop in riveted and bolted bridges are like those in welded bridges. Inspection for fatigue cracks in riveted or bolted bridges should be performed at, but not limited to, the following locations:

1. Rivets/bolts at end connections (check for cracking and prying)
2. End connection angle
3. Girder webs at floor beam connections
4. Floor beam connections to girders
5. Diaphragm connections to girders
6. Cantilever bracket connections to girders
7. Truss hangers
8. Eyebars (see [Figures 5:4-6](#) and [Figures 5:4-7](#))
9. Tack welds
10. Rivet heads and bolts made of certain types and ages of steel on older bridges may have fatigue issues, especially if pack rust has developed between connection members; additional stress may be placed on the nut or rivet head at these locations

The thickness of primary truss gusset plates shall be measured as a part of a Fracture Critical Inspection. If the section cannot be adequately measured with traditional measurement devices, inspectors should use an appropriate NDT technology to assess the gusset plate condition and quantify the plate thickness.

BRIDGE INSPECTION MANUAL

PART 5: BRIDGE INSPECTION

5-5.01(06) Field Inspection Reporting

Each bridge owner has unique requirements and preferences for bridge reporting. The guidelines listed in this section are the minimum reporting requirements for acceptance of a fracture critical inspection report. Although these minimum requirements must be met for acceptance of the report by INDOT, the inspecting agency may provide alternate report formats meeting internal guidelines, if the criteria set forth in this chapter are met. A template Fracture Critical Bridge Inspection report has been provided in Appendix 5B, and a template Fracture Critical Work Plan and Hazard Analysis has been provided in Appendix 5C. The following are minimum requirements for a Fracture Critical Inspection report:

1. Fracture Critical Framing Plan/Diagram identifying all fracture critical members, components, and connections
2. Fracture Critical Inspection Notes and Report (Appendix 5B for template)
3. Fracture Critical Work Plan and Hazard Analysis (Appendix 5C for template)
4. Location Map (BIAS)
5. National Bridge Inspection Data and Item Codes (BIAS)
6. Element Quantities and Condition State Quantities, if applicable (BIAS)
7. Overall condition photographs
8. Photographs of every fracture critical member, connection, or component assigned a condition rating of 4 or less
9. Photographs of each fracture critical member at a frequency of not greater than 10 years (to be included in the bridge file)
10. Photographs of any cracks inspected
11. Documentation of inspection results within the Fracture Critical Inspection Notes and Report; specifically, within the “Table of Fracture Critical Elements Inspection Findings” summary table for each individual fracture critical member, component, and connection, to include the following:
 - a) Individual member rating
 - b) Noted areas of section loss; report section remaining
 - c) AASHTO fatigue category
 - d) Brief condition statement, including the presence of any cracks
 - e) Documentation of fatigue damage

BRIDGE INSPECTION MANUAL

PART 5: BRIDGE INSPECTION

FIGURES

Figure 5:5-1: Fracture Critical Truss Connection

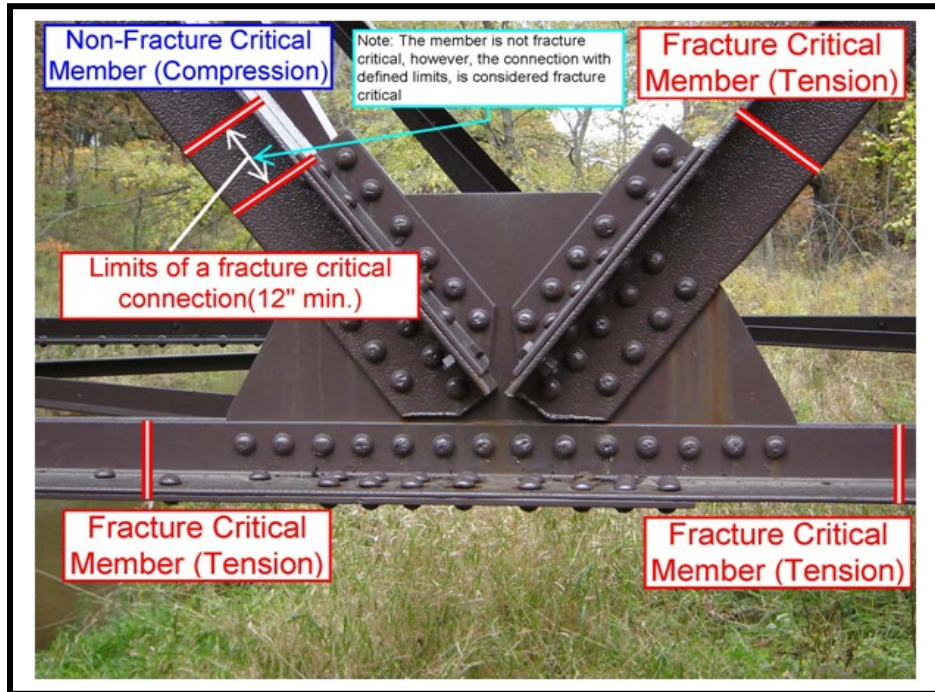
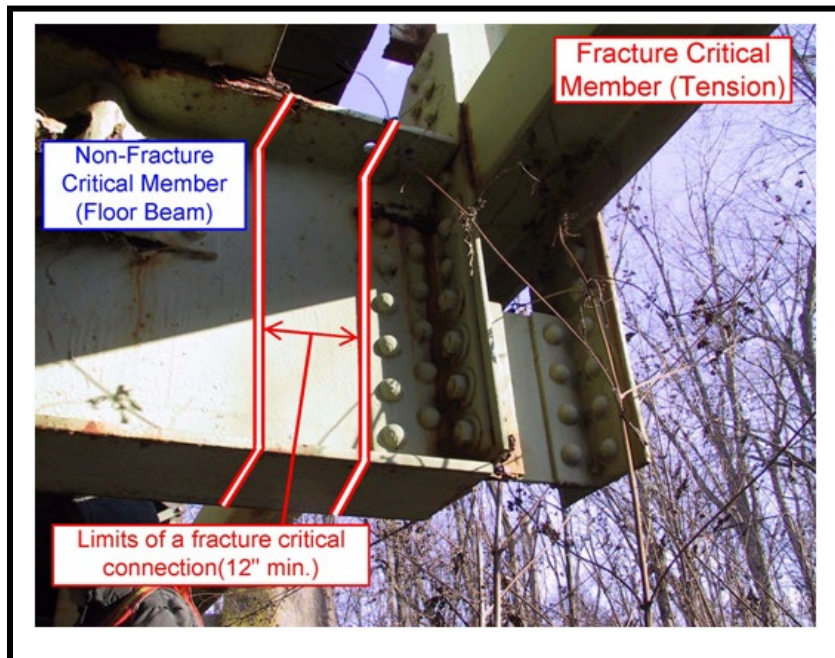

Figure 5:5-2: Fracture Critical Floor Beam Connection



BRIDGE INSPECTION MANUAL

PART 5: BRIDGE INSPECTION

Figure 5-5-3: Fracture Critical Connection at Through Girder

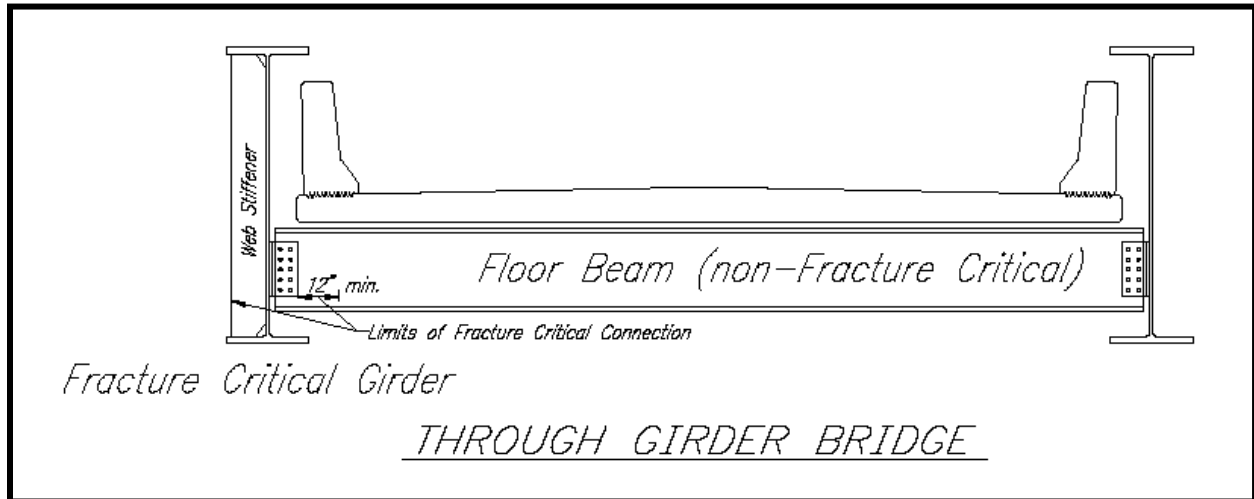
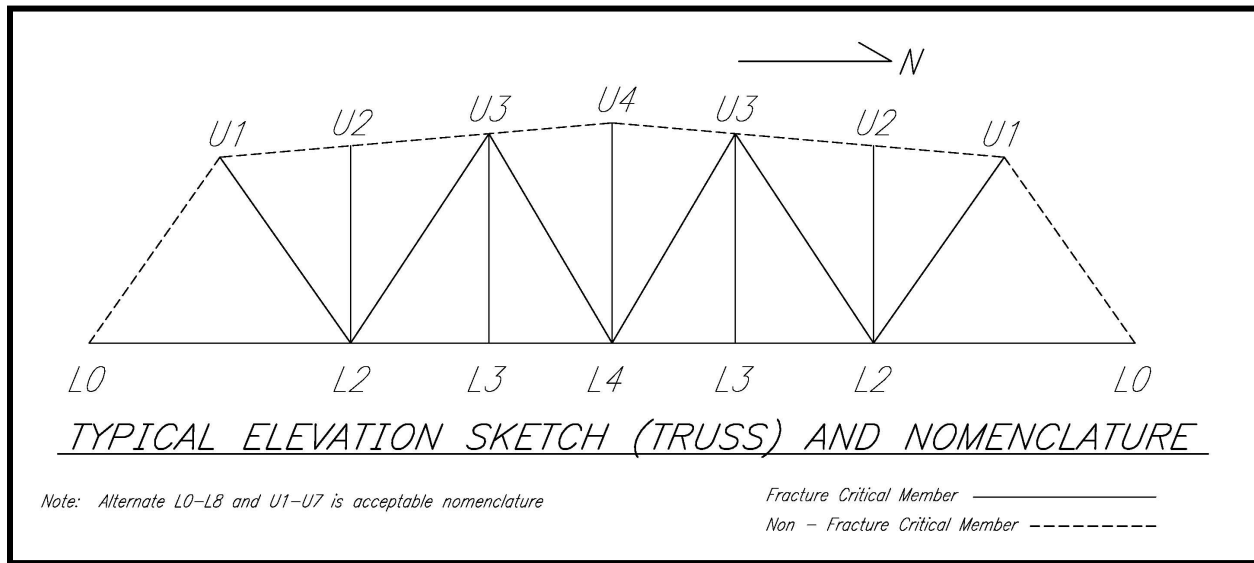

Figure 5-5-4: Example Inspection Plan Sketch (Truss)



BRIDGE INSPECTION MANUAL

PART 5: BRIDGE INSPECTION

Figure 5-5-5: Example Inspection Plan Sketches (Through Girder)

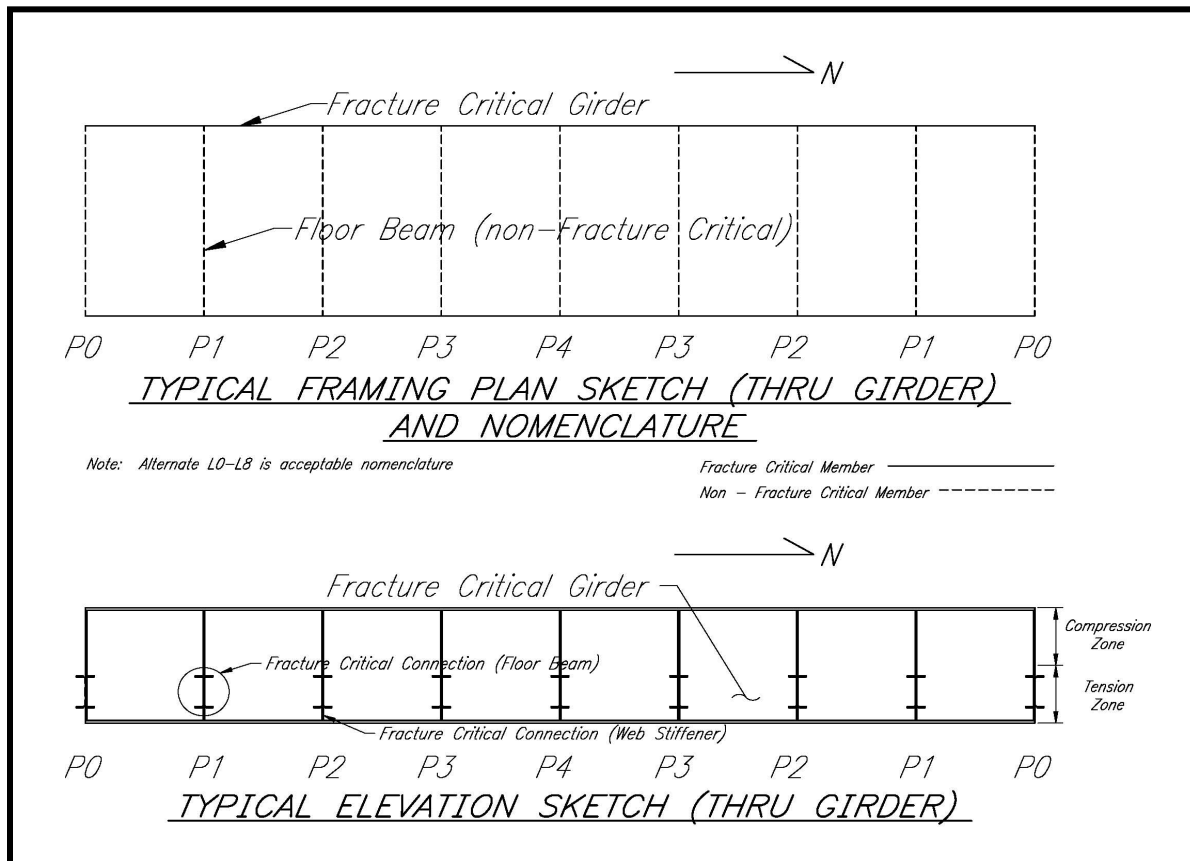
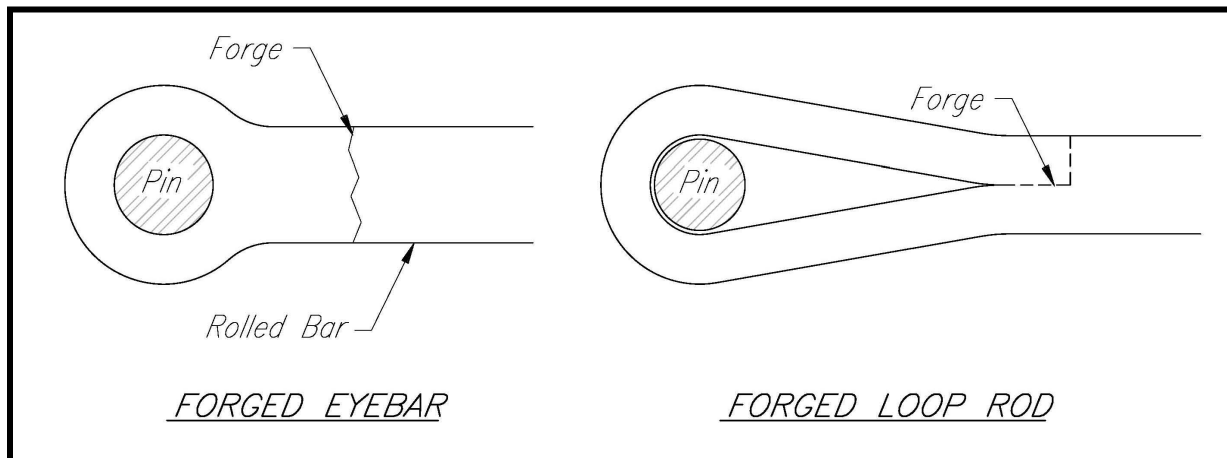

Figure 5-5-6: Typical Pin and Eyebars Details



BRIDGE INSPECTION MANUAL

PART 5: BRIDGE INSPECTION

Figure 5-5-7: Forged Eyebar with Extensive Section Loss

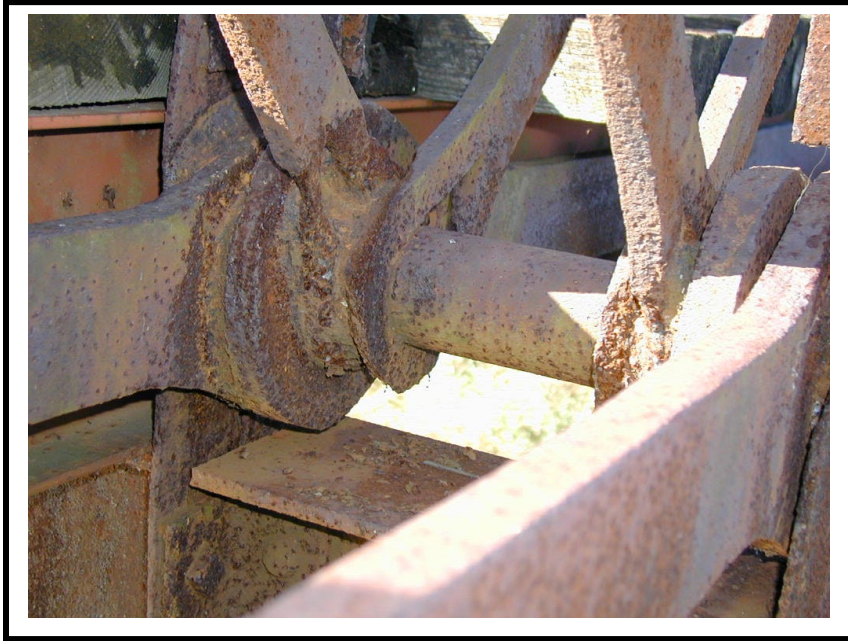

INDOT BRIDGE INSPECTION MANUAL

PART 6

SCOUR

BRIDGE INSPECTION MANUAL

PART 6: BRIDGE INSPECTION

Table of Contents

| | |
|--|----------|
| 6-1.0 SCOUR | 2 |
| 6-1.01 BRIDGE SCOUR EVALUATION PROCEDURES FOR STATE BRIDGES | 2 |
| <i>6-1.01(01) Scour Critical Identification</i> | 2 |
| <i>6-1.01(02) Scour Plan of Action for State Bridges</i> | 2 |
| 6-1.02 BRIDGE SCOUR EVALUATION PROCEDURES FOR LOCAL PUBLIC AGENCY BRIDGES..... | 5 |
| <i>6-1.02(01) Introduction</i> | 5 |
| <i>6-1.02(02) Initial Screening Process</i> | 5 |
| 6-1.03 SCOUR ASSESSMENT/SCOUR ANALYSIS PROCEDURES..... | 5 |
| 6-1.04 SCOUR RATINGS DURING FIELD REVIEWS..... | 8 |
| 6-1.05 BRIDGE SCOUR PLAN OF ACTION (POA) PROCEDURES | 8 |

BRIDGE INSPECTION MANUAL

PART 6: BRIDGE INSPECTION

6-1.0 SCOUR

6-1.01 Bridge Scour Evaluation Procedures for State Bridges

6-1.01(01) Scour Critical Identification

1. Bridge scour vulnerability shall be evaluated and appraised by the INDOT Division of Hydraulics and consulting firms per Chapter 203 of the Indiana Design Manual.
2. NBI Item #113 shall be coded in BIAS by INDOT Bridge Inspectors based on field conditions and/or the result of a scour analysis provided by the INDOT Division of Hydraulics.

6-1.01(02) Scour Plan of Action for State Bridges

A Scour Plan of Action (POA) is required for all Indiana bridges (both State Bridges and LPA Bridges) that have NBI Item # 113 (Scour Critical Bridges) coded 3 or less.

The Scour POA shall be created for each scour critical State Bridge by the District Bridge Inspection Supervisor. The Scour POA shall then be approved by the Bridge Inspection Area Engineer and shall be maintained within the BIAS bridge file for future inspections. The Scour POA template is provided in the Appendix and shall be used for creating the Scour POA for all scour critical State Bridges.

The approved Scour POA for each scour critical bridge shall be updated by the responsible INDOT-Certified bridge inspection team leader following each routine inspection after completing the routine inspection report, but prior to final approval of the report. Before the routine inspection report is approved, the District Bridge Inspection Supervisor shall review the updated Scour POA, and any changes shall be communicated to the district bridge inspection team and other district and central office INDOT personnel as may be required.

6-1.01(03) Initial Scour Inspection Following Trigger Event

An Initial Scour Inspection shall be carried out when the triggering event is either detected, reported, or measured at or near a State Bridge identified as a scour critical bridge.

The scour trigger event for all scour critical State Bridges shall be defined using one of the following three mechanism:

1. Any rainfall event reported at either a USGS or other approved rainfall measuring station either at or near the scour critical bridge that results in 2.5 inches or more of rain in a 24-hour period.
2. When the 50-year flow rate or flood stage (Q_{50}) reported at either a USGS or other approved stream gauge measuring station placed either on the channel at the scour critical bridge or nearby is exceeded. If this trigger event option is selected, the District Bridge

BRIDGE INSPECTION MANUAL

PART 6: BRIDGE INSPECTION

Inspection Supervisor shall coordinate with the INDOT Hydraulics Department to establish an appropriate and measurable Q₅₀ reporting criteria individually for each scour critical bridge.

3. Upon notification of a significant flood event (such as notification that the roadway with one or more scour critical bridges has been closed due to high water) from a recognized and acceptable INDOT Central Office, INDOT District or Subdistrict Office, or County Emergency Management Authority.

Once the trigger event has been either detected, reported, or measured, the District Bridge Inspection Supervisor shall be notified, and an initial scour inspection shall be carried out as soon as feasible.

Resources:

The National Water Information System Web Interface of the U.S. Geological Survey Website is an available resource to bridge inspectors for obtaining current water data. Bridge Inspectors should click on Indiana on the interactive map.

The Water Information Web Interface website is:

<https://waterdata.usgs.gov/nwis/rt>.

For a map of real-time streamflow conditions, Bridge Inspectors should click on the Interactive Indiana Map for a full page view. Bridge Inspectors may then select any of the available stream gauge stations for detailed information collected from that station, including summary, hydrograph, peak, forecast, and rating information. Water Alert email and text message alerts can be set up for any individual station.

Bridge inspectors can obtain precipitation measurements by selecting the “Current Conditions” button, then selecting the “Indiana Precipitation Table” in the Predefined displays and grouping the table by County.

The precipitation website is:

https://waterdata.usgs.gov/in/nwis/current/?type=precip&group_key=county_cd

Precipitation stations may be shown on a map view by selecting the appropriate button. Selecting the individual station number provides additional precipitation data.

If the conditions observed during the initial scour inspection determine that either no appreciable scour has occurred, or that any scour action that has occurred has not resulted in any adverse effects to the bridge or any of its scour critical components, or that any observed effects are not detrimental and can be corrected by INDOT maintenance forces, then no additional monitoring is required.

BRIDGE INSPECTION MANUAL

PART 6: BRIDGE INSPECTION

6-1.01(04) Bridge Scour Monitoring

If conditions during the initial scour inspection are present that do not allow the inspectors to satisfactorily complete their scour inspection during one visit (such as high water that has not receded or high water flow velocity), or if the triggered scour event resulted in adverse effects to any or all scour critical components, or created conditions that threaten the stability or safety of the bridge to public use, then Bridge Scour Monitoring shall be actively carried out through one or more additional inspections. The additional inspections shall be done at intervals established by the District Bridge Inspection District Supervisor and shall be documented in the Scour POA. All observations, measurements, or other actions required during the additional inspections related to the current triggered scour event shall be documented in the Bridge Scour Monitoring Log. The Bridge Scour Monitoring Log template is provided in the Appendix and shall be used for logging all bridge scour monitoring actions done on all scour critical State Bridges. The bridge scour monitoring actions reported in the Scour POA shall include:

1. Monitoring methodology (visual, channel soundings, probing, etc.)
2. Monitoring History and Comments
3. Monitoring Termination Criteria

Subsequent bridge scour monitoring events triggered during future rainfall events shall use separate Bridge Scour Monitoring Logs.

6-1.01(05) Scour Inspection Report

After the conclusion of each triggering event for a scour critical State Bridge, whether the scour critical bridge was monitored or if no monitoring was required, the responsible bridge inspection team leader shall create a Scour inspection report in BIAS that includes:

1. Location Map
2. Narrative paragraph(s) in the Executive Summary describing the scour triggering event, conditions observed, and recommendations for corrective action as warranted
3. National Bridge Inventory form
4. Pictures taken of bridge, the bridge approaches from each end, channel upstream and downstream views, each of the bridge's scour critical components as observed during the initial scour inspection and all subsequent monitoring inspections as a result of the scour triggering event, and other photographs as appropriate
5. Completed and Updated Scour Plan of Action
6. Completed Bridge Scour Monitoring Log (if monitoring was carried out)

The completed Scour Inspection Report shall be submitted to the District Bridge Inspection Supervisor for review and approval.

BRIDGE INSPECTION MANUAL

PART 6: BRIDGE INSPECTION

6-1.02 Bridge Scour Evaluation Procedures for Local Public Agency Bridges

6-1.02(01) Introduction

The expected outcome of the procedure outlined herein is to determine an accurate NBI Item # 113 scour critical rating for each Local Public Agency (LPA) Bridge based on existing documents, field conditions, and engineering judgment, or to determine what documents are needed for an accurate NBI Item # 113 scour critical rating. This process is to be completed utilizing an appropriate combination of office and field reviews. Office reviews shall include, at minimum, a review of the available online bridge files from INDOT and interviews with County staff. It may also include reviewing historical bridge files in the County files that not available online from INDOT. It is anticipated the field reviews would be accomplished concurrently during a routine bridge inspection cycle. The “Scour Evaluator” is responsible for the overall scour evaluation and is required to sign the forms. The “Scour Evaluator” shall be a licensed Indiana Professional Engineer and INDOT-Certified Bridge Inspection Team Leader. It is preferred that these scour evaluation procedures be conducted by a multi-disciplinary team knowledgeable in hydraulic, geotechnical, bridge design, and bridge inspection procedures.

6-1.02(02) Initial Screening Process

Screen each LPA Bridge utilizing the INITIAL SCOUR SCREENING PROCEDURE FOR LOCAL PUBLIC AGENCIES form in Appendix 6A. LPA Bridges with multiple foundations should analyze the worst case. Answer each question and assign either a NA or a Scour Critical Evaluation Rating (NBI Item # 113) per the form. Sign and date the form; then upload the completed form to INDOT’s electronic bridge file. If the assigned Scour Critical Evaluation Rating (NBI Item # 113) from the INITIAL SCOUR SCREENING PROCEDURE FOR LOCAL PUBLIC AGENCIES equals N, 9, or 8; the INDOT Scour Evaluation Procedure is complete for that LPA Bridge.

If the INITIAL SCOUR SCREENING PROCEDURE FOR LOCAL PUBLIC AGENCIES equals NA, the Scour Critical Evaluation Rating (NBI Item # 113) shall not be determined through the Initial Screening Process and the LPA Bridge must be either assessed or analyzed per the Scour Assessment/Scour Analysis Procedures.

6-1.03 Scour Assessment/Scour Analysis Procedures

Utilize the following procedures to determine whether the LPA Bridge will be assessed via the
September 2020

BRIDGE INSPECTION MANUAL

PART 6: BRIDGE INSPECTION

SCOUR ASSESSMENT PROCEDURE FOR LOCAL PUBLIC AGENCIES form in Appendix 6B_or analyzed in accordance with Hydraulic Engineering Circular 18 (HEC-18) in order to assign a Scour Critical Evaluation Rating (NBI Item # 113). See Appendix 6C for HEC-18 guidance.

1. For LPA Bridges with **KNOWN** foundations, identify each bridge as either Moderate Risk or Low Risk. Moderate Risk Bridges are those that cross the rivers and streams identified on the map in Appendix 6D_or as identified by the Inspection Team Leader. Low Risk bridges are all other bridges.
 - a. Analyze each Moderate Risk Bridge by utilizing the procedures in HEC-18 to assign a Scour Critical Evaluation Rating (NBI Item # 113). Additional guidance is in Appendix 6C.
 - b. Assess or Analyze each Low Risk Bridge by either of the following methods:
 - i. Utilize the SCOUR ASSESSMENT PROCEDURE FOR LOCAL PUBLIC AGENCIES form in Appendix 6B_to assign a Scour Critical Evaluation Rating (NBI Item # 113). Answer each question by circling the appropriate answer and, if applicable, assign a Scour Critical Evaluation Rating (NBI Item # 113) per the form. Sign and date the form; then upload the completed form to INDOT's electronic bridge file location. Or:
 - ii. Utilize procedures in HEC-18 to assign a Scour Critical Evaluation Rating (NBI Item # 113).
2. For LPA Bridges with **UNKNOWN** foundations, identify each bridge as either Moderate Risk or Low Risk. Moderate Risk Bridges are those that cross the rivers and streams identified on the map in Appendix 6D_or as identified by the Inspection Team Leader. Low Risk bridges are all other bridges. Use one of the following methods.
 - a. Assign a Scour Critical Evaluation Rating (NBI Item # 113) = "U" and develop a Scour POA, or:
 - b. Analyze each Moderate Risk Bridges by utilizing the procedures in HEC-18 to assign a Scour Critical Evaluation Rating (NBI Item # 113). Additional guidance is in Appendix 6C.
 - c. Determine the foundation type by either of the following methods:
 - i. Use NDE to determine foundation type, OR
 - ii. Infer foundation information based on similar bridges in county built in similar timeframe or year of construction (see FHWA guidance: <http://www.fhwa.dot.gov/unknownfoundations/>); if using inference, document the methodology used.
 - d. Assess or Analyze each Low Risk Bridge by either of the following methods:
 - i. Utilize the SCOUR ASSESSMENT PROCEDURE FOR LOCAL PUBLIC AGENCIES form in Appendix 6B_to assign a Scour Critical Evaluation Rating (NBI Item # 113). Answer each question by circling the appropriate answer and, if applicable, assign a Scour

BRIDGE INSPECTION MANUAL

PART 6: BRIDGE INSPECTION

Critical Rating (NBI Item # 113) per the form. Sign and date the form; then upload the completed form to INDOT's electronic bridge file location. Or:

- ii. Utilize procedures in HEC-18 to assign a Scour Critical Evaluation Rating (NBI Item # 113). Additional guidance is in Appendix 6C.

Infer foundation information based on similar bridges in county built in similar timeframe or year of construction; if using inference, document the methodology used. The following assumptions can be used in lieu of inference:

1. If rock is near surface, spread footings can be assumed.
2. If the top of the spread footing can be located for probing or other means, the bottom of the spread footing can assume to be 3' lower than the top of the footing.
3. If the foundation is unknown, and the pile length cannot be reasonably assured, then treat the bridge as if it is supported on spread footing.

All LPA Bridges with Scour Critical Evaluation Rating (NBI Item # 113) = 0, 1, 2, or 3 are defined as Scour Critical, and a Scour Plan of Action (POA) shall be developed and implemented for each LPA Bridge defined as Scour Critical or with a Scour Critical Evaluation Rating (NBI Item # 113) = U. LPA Bridges not defined as Scour Critical are monitored for scour during routine inspections.

6-1.03. A Definitions:

- **“No signs or history of scour”**: in performing the office and field reviews outlined in the INTRODUCTION, scour was not reported.
- **“Significant scour on Spread Footings”**: any portion of spread footing with more than 1' depth exposure. **“Significant Scour on Piles”**:
 - **End bent/ Abutment with spill slopes**: any exposure of piles deeper than 4' below cap.
 - **Vertical faced abutments**: any exposure of piles.
 - **Interior pile bent/drilled shaft**: any exposure of piles deeper than 3' below normal channel bottom.
 - **Interior bent/pier with footing or mudsill**: any exposure of piles.
- **“Appropriately sized scour countermeasures”**: determination is based on existing study or an engineering judgment. The following should be considered:
 - If the current scour countermeasures are damaged, then they might not be appropriately sized.
 - Class I vs Class II or concrete underpin based on stream velocity.

BRIDGE INSPECTION MANUAL

PART 6: BRIDGE INSPECTION

- Length of service.

- **“Stream banks unstable”:** A stream bank is considered unstable when it is susceptible to erosion (the process by which the land’s surface is worn away by actions of wind, water, ice, and gravity). If the bank is bare, or rills, gullies, or channels are forming, then the bank is considered unstable. Look for bank sloughing, undermining, evidence of lateral movement, or damage to bank stabilization measures. It is also important to look up and down the stream (approximately 200’) for side channels feeding into the primary stream below the bridge for bank stability. Consider NBIS Item 61 as a mean to confirm stream stability conditions.

6-1.04 Scour Ratings During Field Reviews

The most recent FHWA memo regarding Scour Critical Evaluation Rating (Item 113) can be found on the FHWA website.

6-1.05 Bridge Scour Plan of Action (POA) Procedures

Bridge Scour Plans of Action (POAs) are plans that document the action to be taken during a triggering event for scour critical bridges. Scour POAs are required for any bridge with a scour critical rating (NBI Item # 113) of U, 3, or 2. LPA Bridges with a scour critical rating (NBI Item # 113) of 1 or 0 shall be closed and will require either replacement or installation of designed scour countermeasures depending on the condition of the bridge before they can be re-rated and opened to traffic. If the re-rating of these bridges results in a rating (item 113) of U, 3, or 2, a Scour POA shall still be developed. Appendix 6E contains a Scour POA template that will be used for all scour critical State Bridges. A Scour POA created for a LPA Bridge shall be modified to include current responsible bridge inspection team leaders and appropriate local government officials.

Bridge owners are encouraged to mitigate scour risk by installing properly designed countermeasures at bridges. The installation of properly designed scour countermeasures allows NBI Item # 113 to be coded to reflect that the bridge is no longer scour critical and does not require a Scour POA. FHWA Hydraulic Engineering Circular number 23 provides guidance to properly design scour countermeasures.

The bridge owners or their designated representative shall define the scour triggering event to implement the Scour POA for each bridge identified as being a scour critical bridge. The designated representative of the bridge owner shall be an Indiana Licensed Professional Engineer

BRIDGE INSPECTION MANUAL

PART 6: BRIDGE INSPECTION

and an INDOT-certified bridge inspection team leader.

The scour triggering event criteria specified in the Bridge Inspection Manual for State-owned scour critical bridges may be used for LPA Bridges identified as scour critical. Other scour triggering event criteria may be used if they can easily be determined.

An Initial Scour Inspection shall be carried out for each or all LPA Bridge identified as a scour critical bridge when the triggering event criteria is either detected, reported, or measured at each applicable bridge. If the conditions observed during the initial scour inspection determine that no appreciable scour has occurred, or that any scour action that has occurred has not resulted in any adverse to the bridge or any of its scour critical components, or that any observed effects are not detrimental and can be corrected by the bridge owner's maintenance forces, then no further monitoring triggered by that event may be necessary.

The Scour POA shall specify if a monitoring plan can or should be used for the bridge during a flood event or if the bridge will be closed at the triggering event. The monitoring plan shall include what bridge components will be monitored and the frequency that it will be monitored. The name of the responsible person monitoring and maintaining the monitoring log must be included in the monitoring plan.

The closure plan needs to include what will trigger closure. Triggers for closure may be events such as a flood warning, stream reaching bank full condition, water reaching the low structure elevation, road overflow, signs of bridge movement, etc. It needs to include who to contact to get the closure implemented. At a minimum, for local agencies, the County Engineer or County Highway Supervisor shall be notified. The monitoring plan needs to include the name and phone number of that the appropriate contact person(s). The monitoring plan shall also include what bridge components need to be inspected before reopening the bridge. It may require that the flood water recedes before the inspection can take place.

Appendix 6F contains the form that owners should use to document their actions to monitor or close scour critical bridges during triggering events.

The Scour POA and monitoring log (if required) shall be uploaded to BIAS as part of the bridge file.

The Scour POA shall be updated every 24 months, preferably in conjunction with completing the routine inspection report.

INDOT BRIDGE INSPECTION MANUAL

PART 7

WEARING SURFACES

Table of Contents

| | |
|---|---|
| 7-1.0 WEARING SURFACE RATINGS..... | 3 |
| 7-1.01 STRUCTURAL DECKS WITH SACRIFICIAL THICKNESSES CAST MONOLITHICALLY 3 | |
| 7-1.02 RIGID PORTLAND CEMENT CONCRETE (PCC) OVERLAY CONDITION RATINGS. | 4 |
| 7-1.02 SEMI-RIGID EPOXY OVERLAY CONDITION RATINGS | 4 |
| 7-1.03 BITUMINOUS OVERLAY CONDITION RATINGS..... | 5 |

BRIDGE INSPECTION MANUAL

Part 7: WEARING SURFACES

7-1.0 WEARING SURFACE RATINGS

All bridge decks and deck slab superstructures that have **independent, separately placed** overlays using materials that are either rigid Portland Cement concrete, semi-rigid epoxy (or similar approved), or bituminous materials shall have Item 58.01 (Wearing Surface) rated as outlined in Sections 7-1.02, 7-1.03, or 7-1.04 according to the actual type of wearing surface constructed.

All bridge decks and deck slab superstructures that have independent, separately placed overlays **shall not** have Item 108A coded 1 – Monolithic Concrete (concurrently placed with structural deck).

7-1.01 Structural Decks with Sacrificial Thicknesses Cast Monolithically

Bridge decks and deck slab superstructures without **independent, separately placed** wearing surfaces, overlays, or protective systems shall be rated according to the requirements specified in Item 58 of the Recording and Coding Guide for the Structure Inventory and Appraisal of the Nation's Bridges Manual and shall typically match the condition rating assigned for Item 58 (Deck).

Deck topside surfaces that have an upper surface exposed to traffic that consists of a sacrificial thickness cast monolithically during construction at the same time as the originally built structural deck may have an Item 58.01 wearing surface condition rating different from the condition rating assigned for Item 58 (Deck) under the following parameters.

1. Item 108A must be coded 1 – Monolithic Concrete (concurrently placed with structural deck).
2. The condition rating used for Item 58.01 shall use the same condition ratings and descriptions specified for Item 58 in the Coding Guide and shall be for observed deficiencies, such as abrasion/wear, scaling, shallow spalls/popouts, or Element Condition State 2 cracking that affects only the very top, sacrificial portion of the deck and not exceeding 1-1/2" in depth.
3. The mathematical difference between the Item 58 (Deck) and Item 58.01 (Wearing Surface) condition ratings **shall not exceed 1** rating value.
4. The condition rating assessed for Item 58.01 (Wearing Surface) **shall not be larger** than the condition rating assessed for Item 58 (Deck).
5. Conditions observed warranting either the deck or wearing surface to be assessed with a condition rating of 5 or less shall have that same condition rating assigned for both Item 58 (Deck) and Item 58.01 (Wearing Surface).

Otherwise, the following general condition ratings to be reported for BIAS Item 58.01 (Wearing Surface) for each type of **independently or separately placed** wearing surface material specified herein shall be used:

BRIDGE INSPECTION MANUAL

Part 7: WEARING SURFACES

7-1.02 Rigid Portland Cement Concrete (PCC) Overlay Condition Ratings

The following general condition ratings shall be used in evaluating rigid Portland Concrete Cement (PCC) wearing surface overlays. Rigid PCC overlays shall include unmodified Class C concrete, latex modified, dense modified, microsilica modified, or similar approved modified PCC overlays.

Condition Rating Guide for Rigid Portland Cement Concrete Overlays:

| <u>Code</u> | <u>Description</u> |
|--------------------|--|
| N | NOT APPLICABLE - Code N when Item 58 is also coded N. |
| 9 | EXCELLENT CONDITION – no significant defects. |
| 8 | VERY GOOD CONDITION – hairline cracking less than 0.012” nominal width and widely spaced. No surface spalls or patches are present, and no delamination is detected. |
| 7 | GOOD CONDITION - cracking less than 0.016” nominal width, widely spaced, and less than 5% delamination. No surface spalls or patches are present, and no delamination is detected. |
| 6 | SATISFACTORY CONDITION - cracking less than 0.020” nominal width and nominal on center spacing greater than 10 feet. No unpatched surface spalls are present. Patched areas less than 10% of total surface area are present and are all sound. Delamination less than 10% of total surface area is detected. |
| 5 | FAIR CONDITION - cracking greater than 0.020” and less than 0.040” nominal width and nominal on center spacing not greater than 10 feet. Few intermittent unpatched surface spalls or unsound patches less than 5% of the total surface area are present. Sound patched areas less than 20% of the total surface area are visible. Delamination less than 20% of the total surface area is detected. |
| 4 | POOR CONDITION – cracking greater than 0.040” nominal width and nominal on center crack spacing less than 10 feet. Delamination greater than 20% of the total surface area is detected. Unpatched or unsound patching, or spalled areas, are visible across less than 10% of the total surface area. |
| 3 | SERIOUS CONDITION - delamination greater than 20% of the total surface area is detected. Extensive severe and closely spaced cracking, unpatched or unsound patches, and spalled areas are visible across more than 10% of the total surface area and widespread. The wearing surface is no longer effective. |

Condition ratings less than 3 shall not be coded.

7-1.02 Semi-Rigid Epoxy Overlay Condition Ratings

The following general condition ratings shall be used in evaluating a semi-rigid (epoxy, polyester, or similar approved material) wearing surface:

Condition Rating Guide for Semi-Rigid Epoxy Overlays

| <u>Code</u> | <u>Description</u> |
|--------------------|---|
| N | NOT APPLICABLE – Code N when Item 58 is also coded N. |
| 9 | EXCELLENT CONDITION – no visible defects or visible wearing of the friction surface aggregate. |
| 8 | VERY GOOD CONDITION – minor intermittent wearing of the friction surface aggregate across less than 5% total surface area within the travel lanes. |
| 7 | GOOD CONDITION – minor wearing, glazing, or polishing of the friction surface aggregate across less than 40% total surface area within the travel lanes. |
| 6 | SATISFACTORY CONDITION – deep wearing, glazing, or polishing of the friction surface aggregate across more than 40% total surface area. Less than 5% total surface area exhibiting areas of full thickness wearing down to bare deck, surface voids, or peeling. For this condition rating or lower, areas of full thickness material loss that are visible within 6” of bridge deck joints shall not be included within these condition rating parameters. |
| 5 | FAIR CONDITION – Greater than 5% and less than 10% total surface area exhibiting areas of full thickness wearing down to bare deck, surface voids, or peeling. |
| 4 | POOR CONDITION – Greater than 10% and less than 15% total surface area exhibiting areas of full thickness wearing down to bare deck, surface voids, or peeling. |
| 3 | SERIOUS CONDITION – Greater than 15% of the total surface area exhibiting areas of full thickness wearing down to bare deck, surface voids, or peeling. The wearing surface is no longer effective. |

Condition ratings less than 3 shall not be coded.

7-1.03 Bituminous Overlay Condition Ratings

The following general condition ratings shall be used in evaluating a flexible bituminous material wearing surface. All bituminous material overlays on State or Tollway-owned bridges shall be placed on an agency approved waterproofing membrane system. All bituminous material overlays placed on State or Tollway owned bridges that do not have an agency approved waterproofing membrane system between the wearing surface and deck shall be rated 4.

| <u>Code</u> | <u>Description</u> |
|--------------------|--|
| N | NOT APPLICABLE – Code N when Item 58 is also coded N. |
| 9 | EXCELLENT CONDITION – no significant defects, cracks, spalls, or voids visible. |
| 7 | GOOD CONDITION – shallow wearing or rutting of the bituminous surface visible in the travel lanes. No wide cracks, spalls, or voids visible. All cracks present are sealed, |

BRIDGE INSPECTION MANUAL

Part 7: WEARING SURFACES

and all spalls and voids are soundly patched.

- 5 **FAIR CONDITION** – moderate wearing or rutting of the bituminous surface visible across more than 30% of the travel lanes. No wide cracks, spalls, or voids visible. All cracks present are sealed, and all spalls and voids are soundly patched.
- 4 **POOR CONDITION** – moderate wearing or rutting of the bituminous surface visible across more than 30% of the travel lanes. Unsealed cracks and unpatched spalls or void visible across less than 10% of the total surface area.
- 3 **SERIOUS CONDITION** – widespread wearing or rutting of the bituminous surface visible across the travel lanes. Unsealed cracks and unpatched spalls or void visible across more than 10% of the total surface area. The wearing surface is no longer effective.

Only the condition ratings listed in this section shall be coded.

INDOT BRIDGE INSPECTION MANUAL

PART 8

ASBESTOS

BRIDGE INSPECTION MANUAL

Part 8: ABESTOS

Table of Contents

| | |
|----------------------------------|---|
| 8-1.0 ASBESTOS..... | 3 |
| 8-1.01 Asbestos Inspections..... | 3 |
| 8-1.01(01) Asbestos Report | 3 |
| 8-1.01(02) Definitions: | 4 |

BRIDGE INSPECTION MANUAL

Part 8: ABESTOS

8-1.0 ASBESTOS

8-1.01 Asbestos Inspections

In accordance with Rule 10. Emission Standards for Asbestos; Demolition and Renovation Operations. 326-IAC 14-10-1 Applicability (a)...prior to the commencement of the demolition or renovation, the owner shall use an Indiana licensed asbestos inspector to inspect thoroughly the affected facility or part of the facility where the demolition or renovation operation will occur for the presence of asbestos, including Category I and Category II nonfriable asbestos-containing material (ACM).

8-1.01(01) Asbestos Report

The determination of the presence of asbestos will be determined and reported in an asbestos report. The report will be created in BIAS and will be available for inclusion in a contract for work appropriately determined to include demolition of all or a portion of the structure.

The report created in BIAS will include the following items as a minimum:

- A cover sheet which will list the structure number, the inspection date, inspectors name and the inspector's license number.
- A structure data sheet which will include the date of the asbestos inspection, structure number, NBI number, and the year the structure was built. The structure data sheet will clearly state if the structure contains asbestos. The structure data sheet will clearly state if the structure has asbestos utility pipes attached.
- If suspect materials are found on the bridge, the material will be described as friable, non-friable, category 1 or category 2 nonfriable asbestos-containing material.
- Each location and different material will be located and described. The findings for each material will be recorded on the structure data sheet.
- As a minimum, a picture of the bridge profile will be included in the report
- If suspect materials are found, a picture with each suspect material will be included in the report. The sampling location will be clearly identified in the picture for each suspect material.
- The completed chain of custody form will be attached to the completed report.
- A quantity computation and location sketch will be attached for each suspect material.
- The completed report will be uploaded in BIAS.

BRIDGE INSPECTION MANUAL

Part 8: ABESTOS

8-1.01(02) Definitions:

- (3) "Asbestos" means an asbestiform variety of the following:
 - (A) Chrysotile (serpentine).
 - (B) Crocidolite (riebeckite).
 - (C) Amosite (cummingtonite-grunerite).
 - (D) Anthophyllite.
 - (E) Tremolite.
 - (F) Actinolite.
- (5) "Asbestos-containing material" or "ACM" means asbestos or any material containing more than one percent (1%) asbestos as determined using methods specified in 40 CFR 763, Subpart E, Appendix E, Section I, Polarized Light Microscopy*, including Category I and Category II asbestos-containing material and all friable material.
- (10) "Category I nonfriable asbestos-containing material (ACM)" means asbestos-containing packings, gaskets, resilient floor covering, and asphalt roofing products containing more than one percent (1%) asbestos as determined using the method specified in 40 CFR 763, Subpart E, Appendix E, Section 1, Polarized Light Microscopy*.
- (11) "Category II nonfriable asbestos-containing material (ACM)" means any material, excluding Category I nonfriable ACM, containing more than one percent (1%) asbestos as determined using the method specified in 40 CFR 763, Subpart E, Appendix E, Section 1, Polarized Light Microscopy* that, when dry, cannot be crumbled, pulverized, or reduced to powder by either hand pressure or mechanical forces reasonably expected to act on the material.
- (14) "Demolition" means the wrecking or taking out of any load-supporting structural member of a facility together with any related handling operations or the intentional burning of any facility.
- (18) "Friable asbestos material" means any material containing more than one percent (1%) asbestos as determined using the method specified in 40 CFR 763, Subpart E, Appendix E, Section 1, Polarized Light Microscopy*, that, when dry, can be crumbled, pulverized, or reduced to powder either by hand pressure or mechanical forces reasonably expected to act on the material. If the asbestos content is less than ten percent (10%) as determined by a method other than point counting by polarized light microscopy (PLM), verify the asbestos content by point counting using PLM.
- (29) "Nonfriable asbestos-containing material" means any material containing more than one percent (1%) asbestos as determined using the method specified in 40 CFR 763, Subpart E, Appendix E, Section 1, Polarized Light Microscopy*, that, when dry, cannot

BRIDGE INSPECTION MANUAL

Part 8: ABESTOS

be crumbled, pulverized, or reduced to powder by either hand pressure or mechanical forces reasonably expected to act on the material.

INDOT BRIDGE INSPECTION MANUAL

PART 9

ENVIRONMENTAL CONCERNS

BRIDGE INSPECTION MANUAL

PART 9: ENVIROMENTAL CONCERNS

Table of Contents

| | |
|-----------------------------------|----------|
| LIST OF FIGURES | 2 |
| 9-1.0 BATS AND BIRDS | 3 |
| 9-0.01 INTRODUCTION..... | 3 |
| 9-1.00 HABITAT DETECTION..... | 3 |
| 9-2.00 CODING..... | 4 |
| FIGURES..... | 5 |

LIST OF FIGURES:

| <u>Figures</u> | <u>Titles</u> |
|----------------|---|
| 9-1.1 | Cliff Swallow Nests |
| 9-1.2 | Cliff Swallow Colony |
| 9-1.3 | Single Barn Swallow Nest |
| 9-1.4 | Bat Droppings |
| 9-1.5 | Bats Roosting Along Crack and Associated Staining |
| 9-1.6 | Bat Guano on Riprap |
| 9-1.7 | Bat |

BRIDGE INSPECTION MANUAL

PART 9: ENVIRONMENTAL CONCERNS

9-1.0 BATS AND BIRDS

9-0.01 Introduction

Some species of bats are listed as endangered or threatened under the federal Endangered Species Act, and many species of birds are protected under the Migratory Bird Treaty Act. Both federal laws prohibit actions that harm these animals. Bats and birds may use bridges for roosting or nesting, which means they could be harmed by construction activities. Inspectors must perform a preliminary screening for bats and cliff swallows as a part of each inspection for state-owned bridges.

9-1.00 Habitat Detection

Some species of bird's nest under highway bridges on walls or beams, typically near waterways or reservoirs. In particular, inspectors should look for two types of swallow nests. Cliff swallow nests have a distinctive rounded top, as shown above in **Figure 9-1.1** and **Figure 9-1.2**. Cliff swallows are a colony nesting bird and there may be several to hundreds under one bridge.

Barn swallows do not nest in colonies. Their nests are generally found alone, and the shape is indistinct, as shown in **Figure 9-1.3**. Barn swallows are not tracked by the Indiana State Department of Natural Resources but are discussed here to highlight the differences between cliff swallows and barn swallows. Other bird nests, such as those of robins and warblers, may also be found and should be documented in the inspection.

Bats may roost in any dark, warm, quiet spot on a bridge, which makes them more difficult to see during an inspection as shown in **Figure 9-1.4**. Most bats in Indiana are very small, see **Figure 9-1.7** about the size of an adult's thumb, and some species prefer to wedge into small crevasses to roost as shown in **Figure 9-1.5**. Bats may leave signs of use, such as guano or staining, even if a structure is inspected during the bats' inactive season (mid-fall through mid-spring) or if the roosting bats themselves are not visible as seen in **Figure 9-1.6**. Droppings are usually small and mouse-like, brown, or black, and appear directly under the roost site. Urine stains are usually a few inches in size immediately below roosts and may have a strong odor. Stains from fur oil may also be visible at the entrance to cavity roosts. INDOT's Environmental Services Division has developed a short online tutorial about investigating structures for bats. This tutorial is available through INDOT University.

Take care not to touch any bats or expose yourself to danger. If bitten, call the Department of Health at 317-233-1325 and record the incident immediately. Few bats have rabies; however, it is a deadly virus. If bitten by a bat, you will need rabies post-exposure shots.

BRIDGE INSPECTION MANUAL

PART 9: ENVIROMENTAL CONCERNS

In general, investigation of the structure should include the following:

1. Screen the entire structure for bird nests and provide photographs.
2. Look for roosting bats in sheltered features of the structure, including all protected joints, cracks, and small cavities.
3. Look for signs of bat use. Note the location of guano piles, urine stains, and fur stains.
4. Listen for squeaks or chirps and note location.
5. Photograph roosting bats, guano, urine, or fur stains.

9-2.00 Coding

The presence of bats, birds, or signs of bat or bird use, are recorded in the inspection report. Follow the prompts in the fields on the inspection report data entry form and add photographs of what is found.

BRIDGE INSPECTION MANUAL

PART 9: ENVIROMENTAL CONCERNS

FIGURES

9-1.1 Cliff Swallow Nests



9-1.2 Cliff Swallow Colony



BRIDGE INSPECTION MANUAL
PART 9: ENVIROMENTAL CONCERNS

9-1.3 Single Barn Swallow Nest



9-1.4 Bat Droppings



BRIDGE INSPECTION MANUAL
PART 9: ENVIROMENTAL CONCERNS

9-1.5 Bats Roosting Along Crack and Associated Staining



9-1.6 Bat Guano on Riprap



BRIDGE INSPECTION MANUAL
PART 9: ENVIROMENTAL CONCERNS

9-1.7 Bat



BRIDGE INSPECTION MANUAL

APPENDICES: BRIDGE INSPECTION

APPENDIX 2A:

How to complete a Delinquent Inspection Form

1. Download this document and open on local format (download is located on far right of this page)
2. Once document is open proceed to editable pdf Delinquent Inspection form and fill in the blanks required for your situation and save document.
3. Open BIAS and bring up the asset that is going to be late

4. Click on the FILES tab

Asset Details: Test Asset 4

| | | | |
|------------|------------|--------------|-------------|
| Quick View | Asset Info | Files | Maintenance |
|------------|------------|--------------|-------------|

Attach Picture/File

5. Select Delinquent Inspection from the drop-down box
6. Select the reason for the delinquency

File Type **Delinquent Inspectic**

- Act of God / Nature
- Contract Issues
- Notice to Proceed Late
- Other

7. Select the date of notice

File Date (i.e. Date Picture Taken): 08/14/2020

Set description to file name on Attach

8. Select saved Delinquent Inspection Form

BRIDGE INSPECTION MANUAL

APPENDICES: BRIDGE INSPECTION

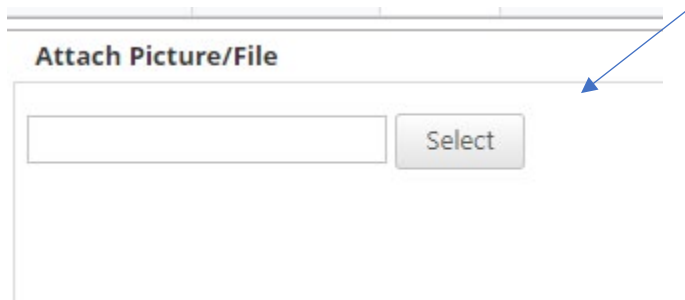

- 9. Save attachment
- 10.

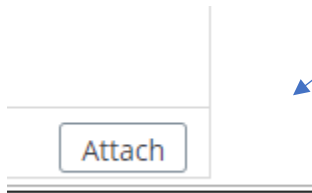

- 11. It should show up in the file for Delinquent Inspection

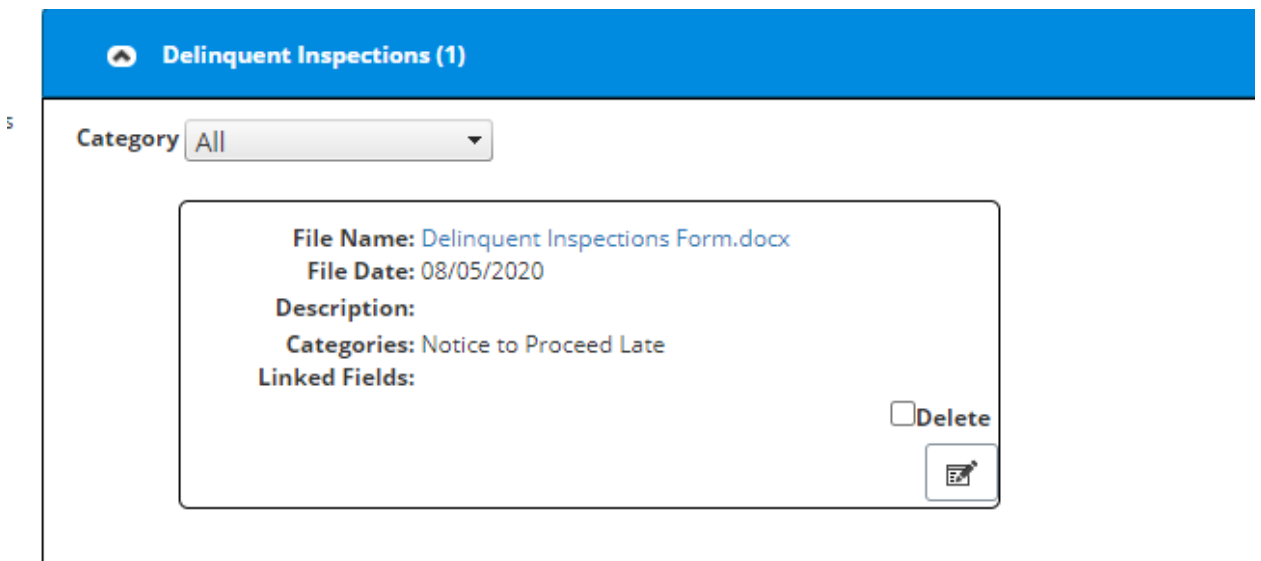

You are done.

*****If multiple bridges (10 or more) or an entire county are going to be delinquent the County Consultant BIAS admin or the Lead Team Leader needs to contact INDOT for mass upload of all delinquent bridges.**

**BRIDGE INSPECTION MANUAL
APPENDICES: BRIDGE
INSPECTION
APPENDIX 4A:**

Appendix A: NBIP File Review Checklist

Structure No.:

Review Date: _____

Item 1 - State:

Review Performed by: _____

Item 7 - Feature Carried:

Item 6A - Feature Crossed:

Item 27 - Year Built:

Item 90 - Most Recent NBIS Insp. Date:

Metrics assessed in file review:

M12 M13 M14 M15 M16 M17 M18 M22 M23

Metric 12 – Inspection Procedures – Quality Inspections

NBI Data

Item 58:

Risk Category:

Item 59:

Item 65 – Inventory Rating Method:

Item 60:

Does the narrative justify given ratings?

Item 62:

Review Observations

Metric 12 Notes:

BRIDGE INSPECTION MANUAL

Part 2: QA / QC

| Metric 18 – Inspection Procedures, Scour Critical Bridges | | | |
|--|--|--|--|
| NBI Data | | | |
| Item 113: | | | |
| Review Observations | | | |
| Scour evaluation in bridge record (Y/N): | | Event Response | |
| Scour POA Developed (Y/N): | | Has there been a triggering event (Y/N): | |
| Scour POA Implemented (Y/N): | | Was POA executed (Y/N): | |
| Trigger Events and Tracking Methodology Identified in POA (Y/N) | | | |
| Metric 18 Notes: | | | |
| | | | |

| Metric 22 – Inventory – Prepare and Maintain | | | |
|---|---|--|--|
| Directions: Selected NBI items to be reviewed for accuracy | | | |
| NBI Data | | | |
| Review Observations | | | |
| 1. | Verify inspection dates for items 90, 93A, 93B, 93C | | |
| 2. | Verify inspection frequencies in items 91, 92A, 92B, and 92C updated and correct based on condition | | |
| 3. | Verify items 94, 95, 96, and 97 updated | | |
| 4. | Verify element level data and quantity computations on NHS bridges | | |
| Metric 22 Notes: | | | |
| | | | |

| Metric 23 - Inventory – Timely Updating of Data | |
|--|--|
| NBI Data | |
| 60 Day requirement: | |
| Metric 23 Notes: | |
| | |

BRIDGE INSPECTION MANUAL

APPENDICES: BRIDGE INSPECTION

APPENDIX 5A:FRACTURE CRITICAL EXAMPLES

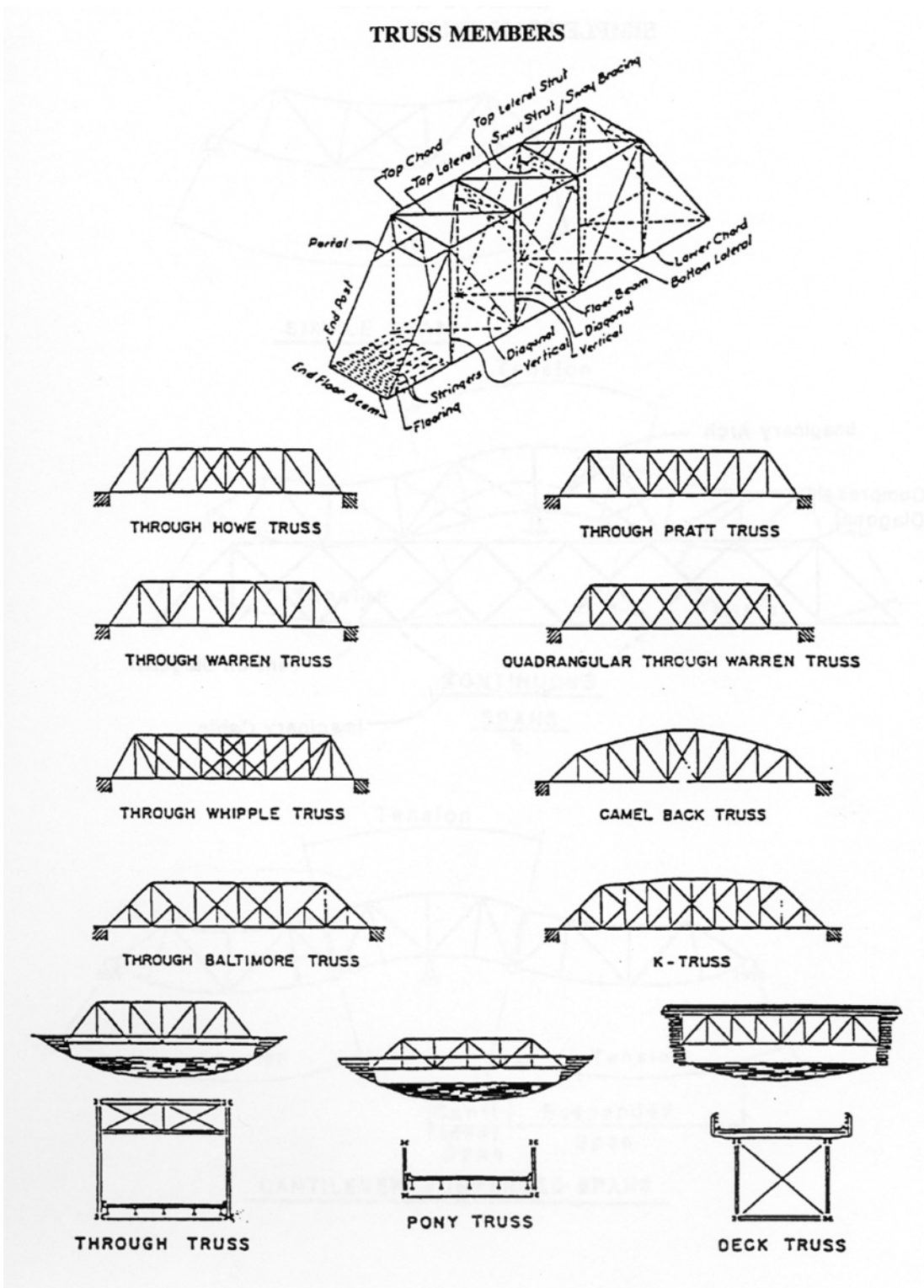

BRIDGE INSPECTION MANUAL

APPENDICES: BRIDGE INSPECTION

SIMPLE SPAN TRUSS

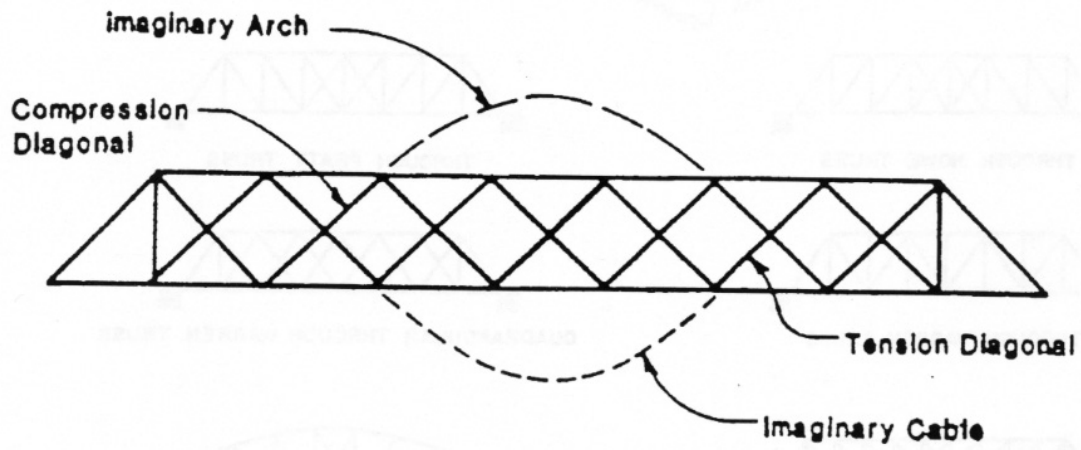

BRIDGE INSPECTION MANUAL

APPENDICES: BRIDGE INSPECTION

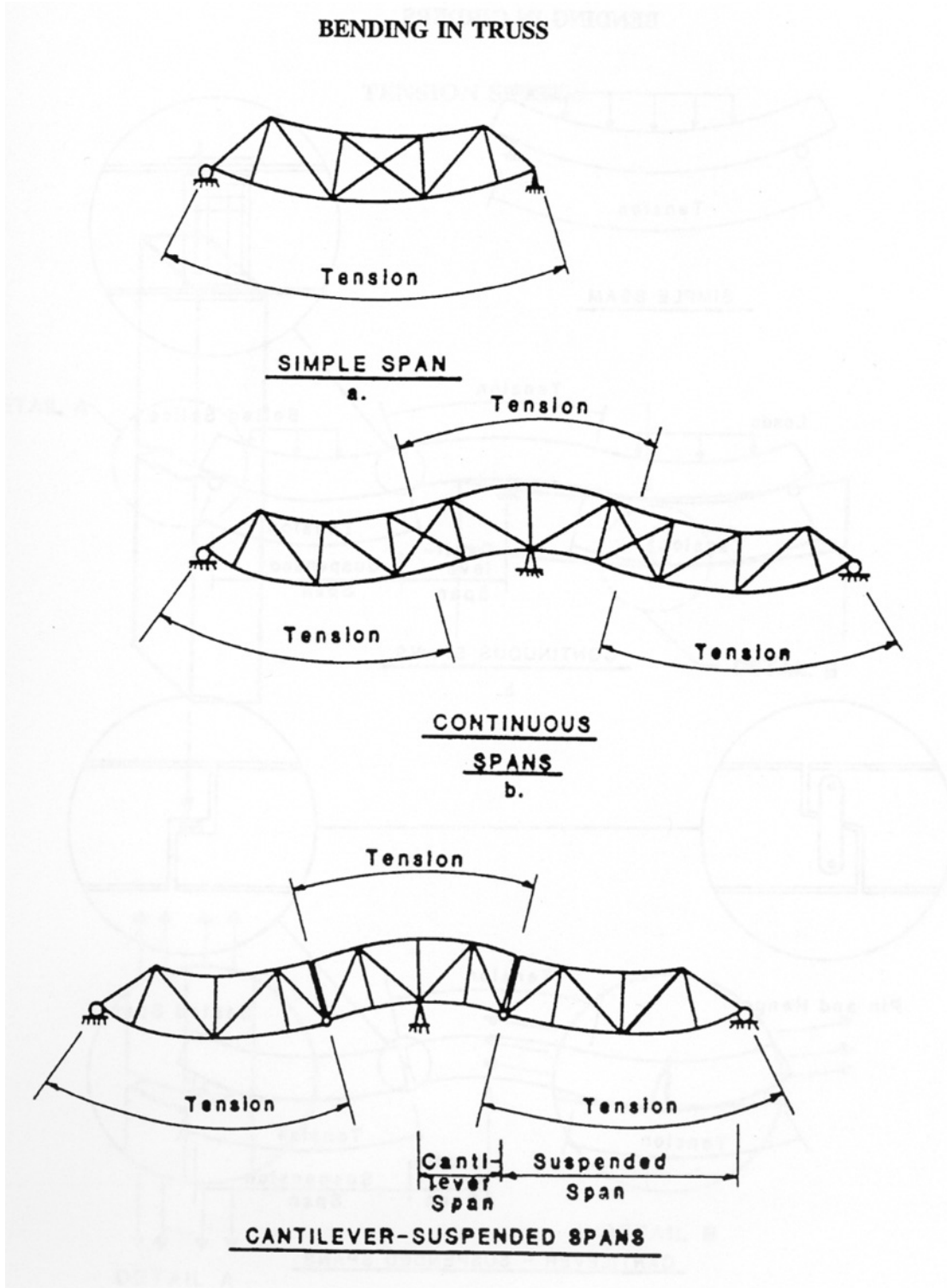

BRIDGE INSPECTION MANUAL

APPENDICES: BRIDGE INSPECTION

BENDING IN GIRDERS

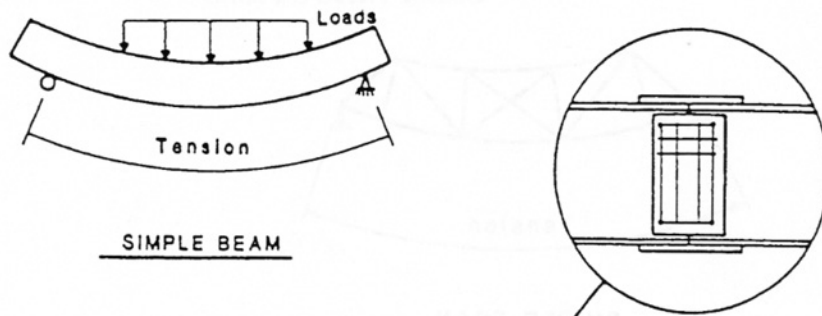

SIMPLE BEAM

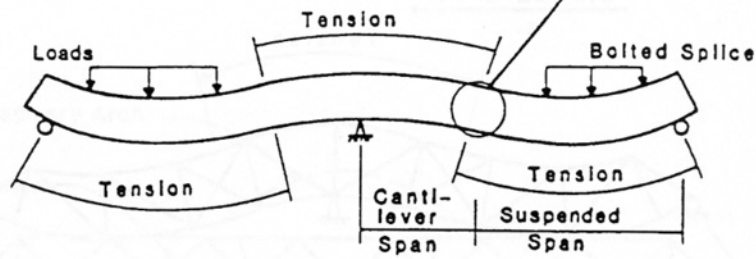

CONTINUOUS SPANS

b.

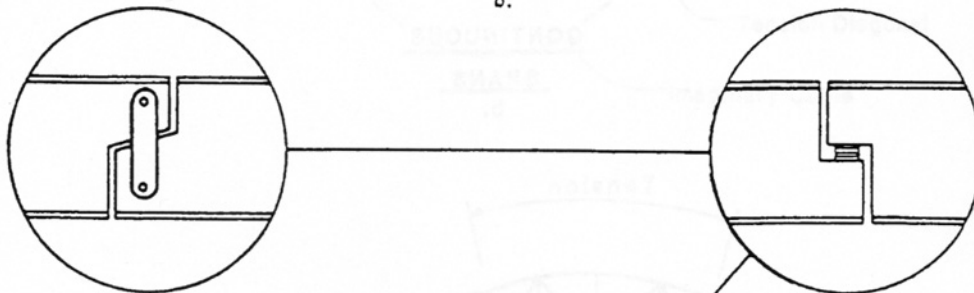

Pin and Hanger

Seated Span

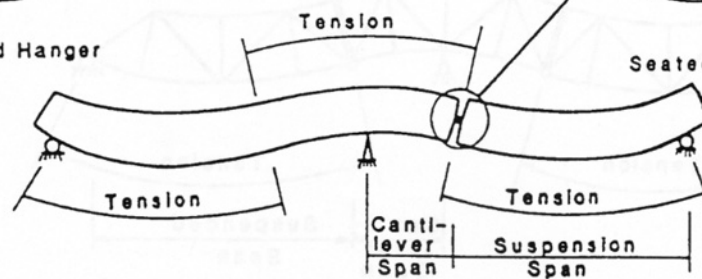

c.

CANTILEVER - SUSPENDED SPANS

BRIDGE INSPECTION MANUAL

APPENDICES: BRIDGE INSPECTION

TENSION STRESS

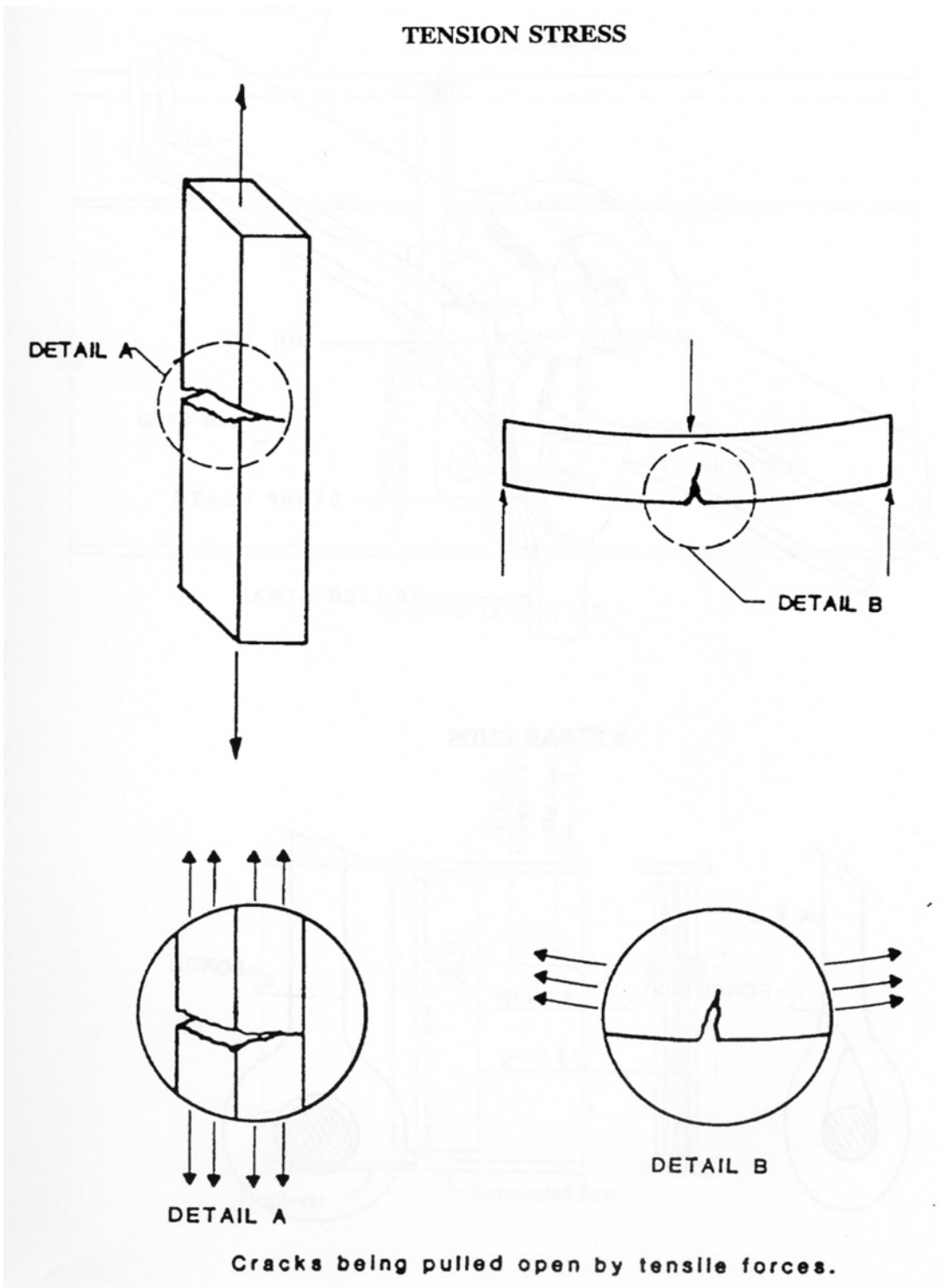

BRIDGE INSPECTION MANUAL

APPENDICES: BRIDGE INSPECTION

EYEBAR HANGER CONNECTION

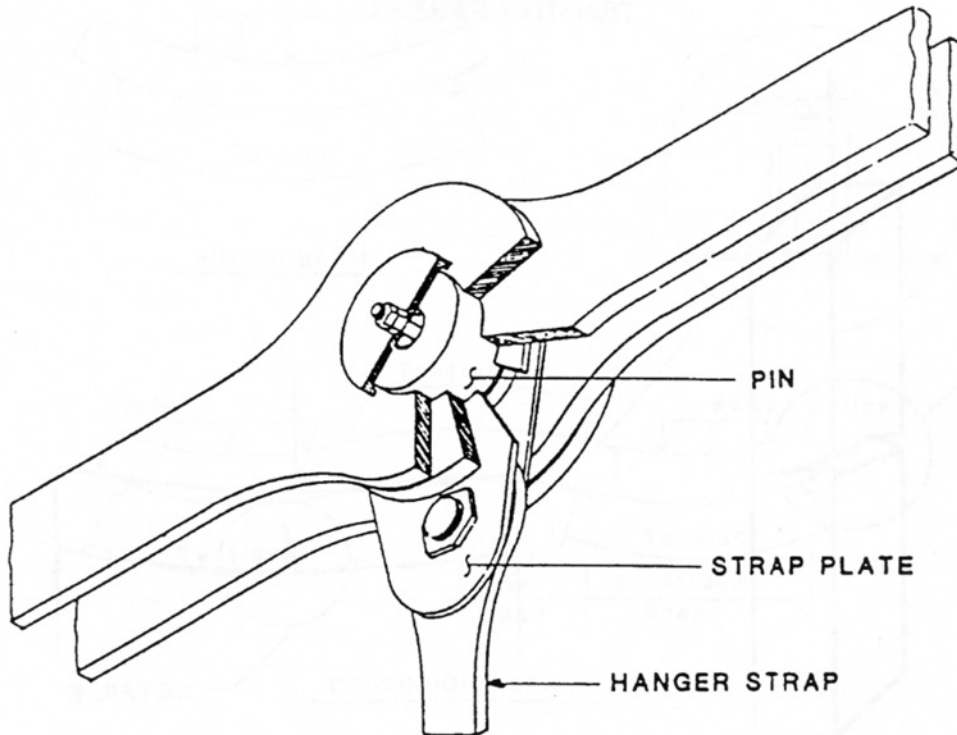

EYEBAR ENDS

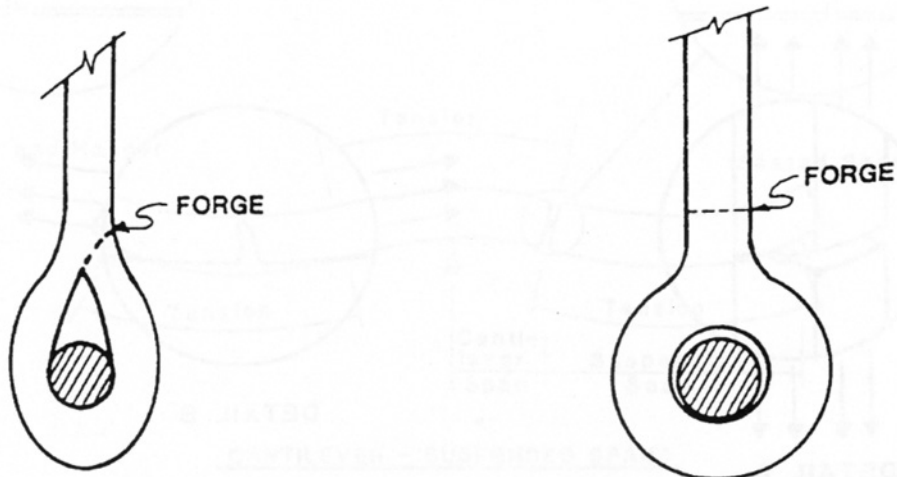

Fatigue Categories A, B (on eyebar body), or E (on net section of eyebar head)

BRIDGE INSPECTION MANUAL

APPENDICES: BRIDGE INSPECTION

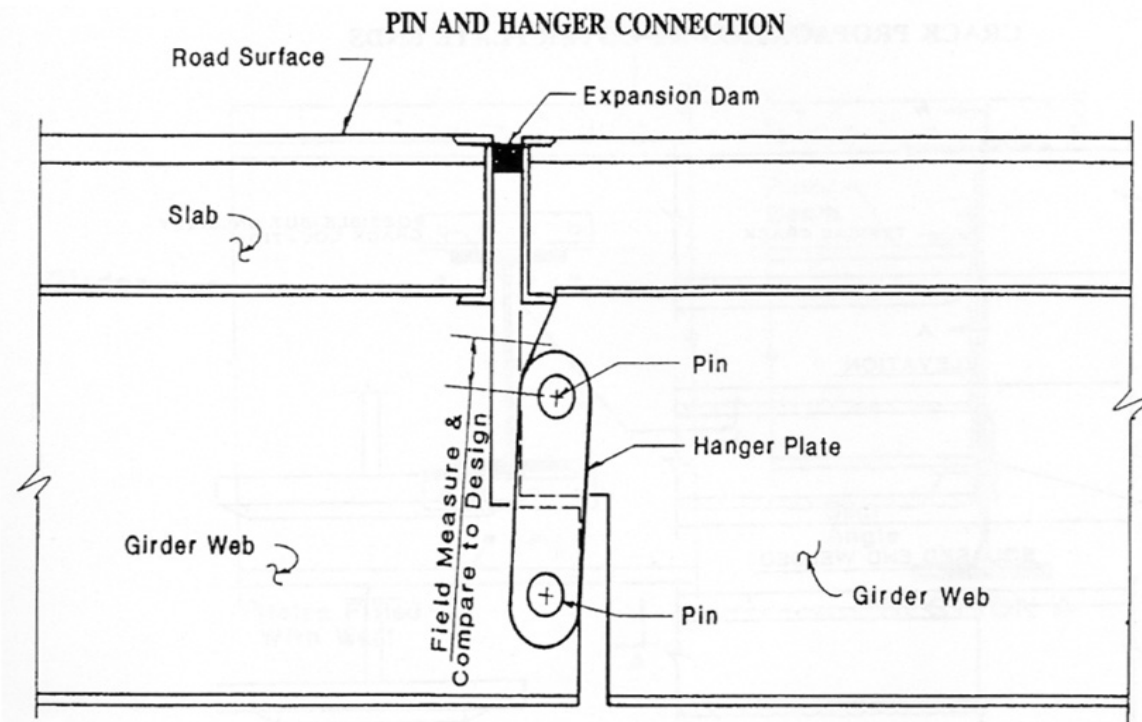

FIXED PIN CONNECTION

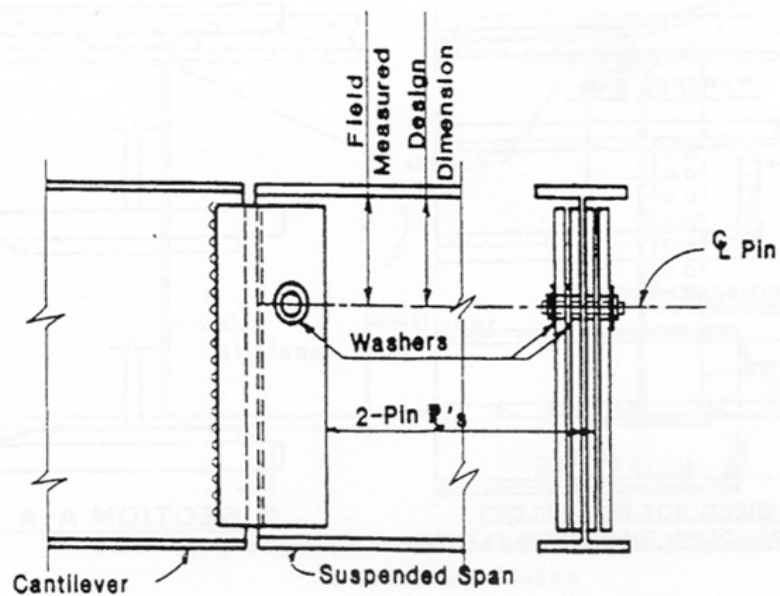

Fatigue Category A, B (on hanger plate body), or E (on net section of hanger or pin plate)

BRIDGE INSPECTION MANUAL

APPENDICES: BRIDGE INSPECTION

CRACK PROPAGATION AT COVER PLATE ENDS

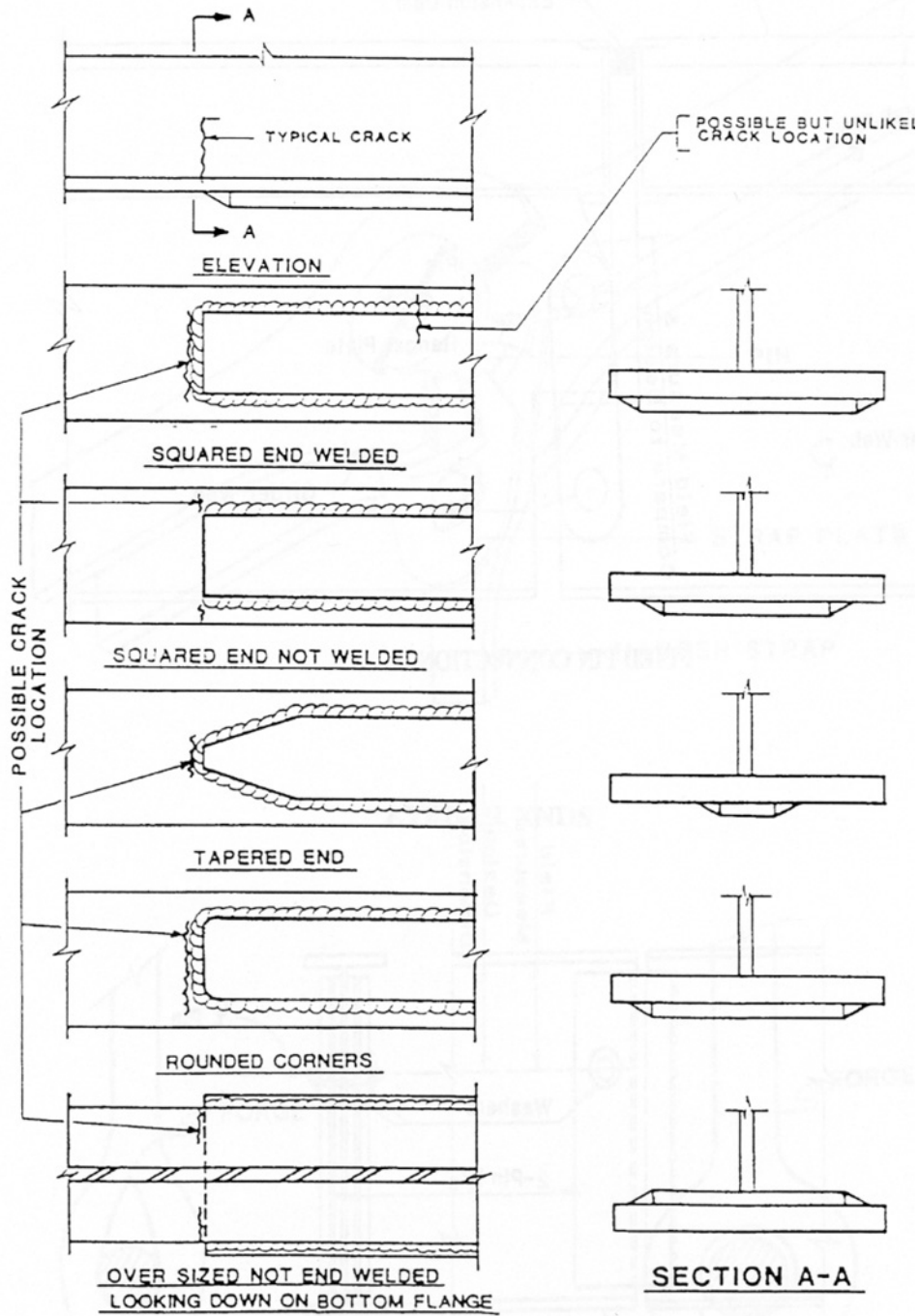

Fatigue Categories E and E'

BRIDGE INSPECTION MANUAL

APPENDICES: BRIDGE INSPECTION

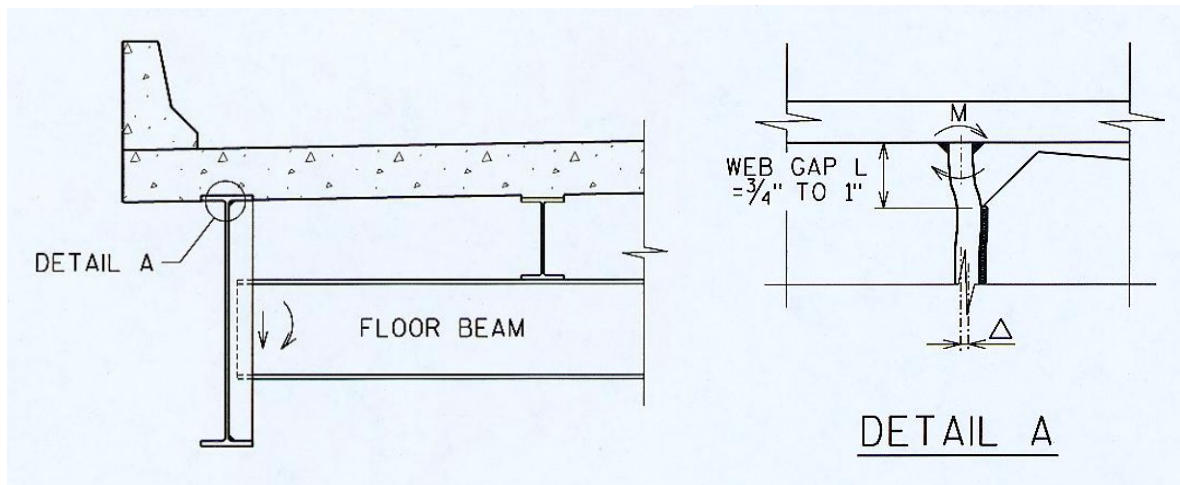
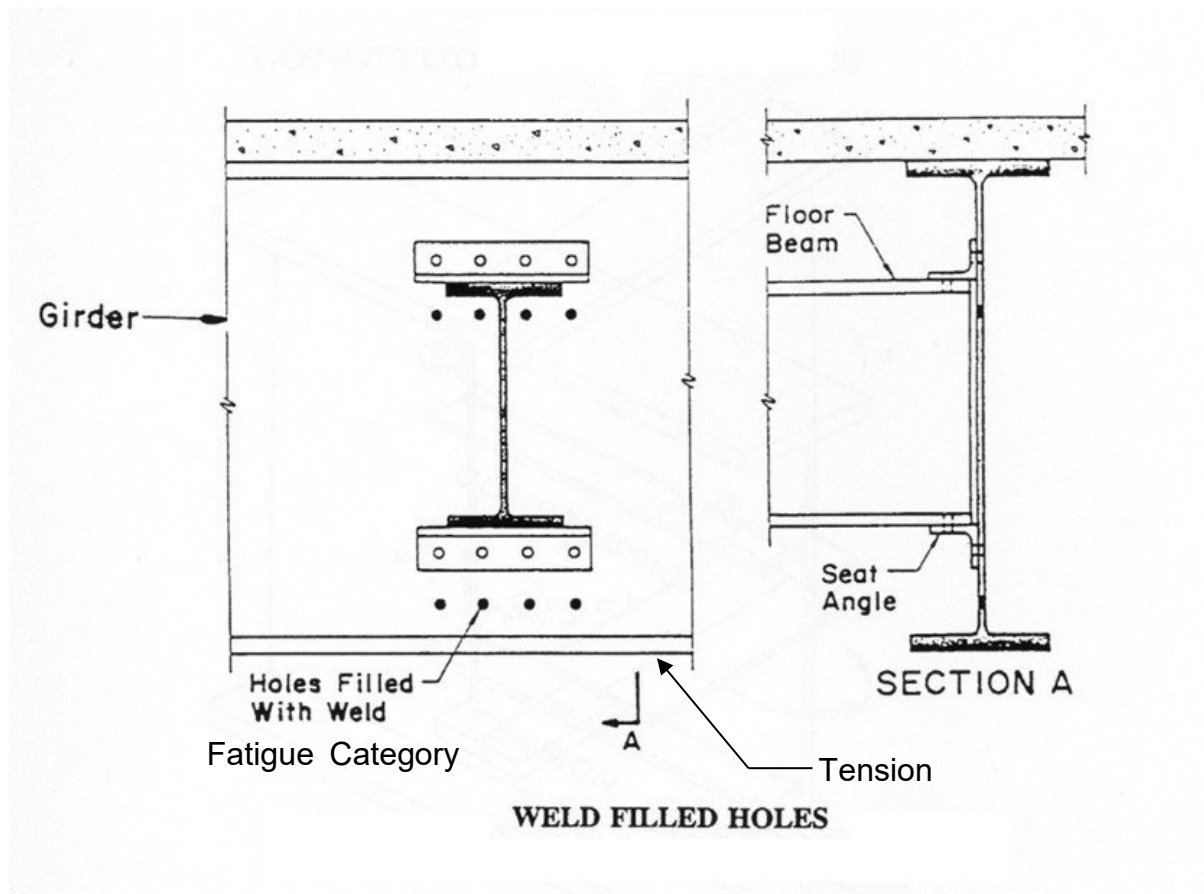

Web Out-of-Plane Bending at Floor Beam Connection Plate

BRIDGE INSPECTION MANUAL

APPENDICES: BRIDGE INSPECTION

FLANGE AND WEB ATTACHMENTS

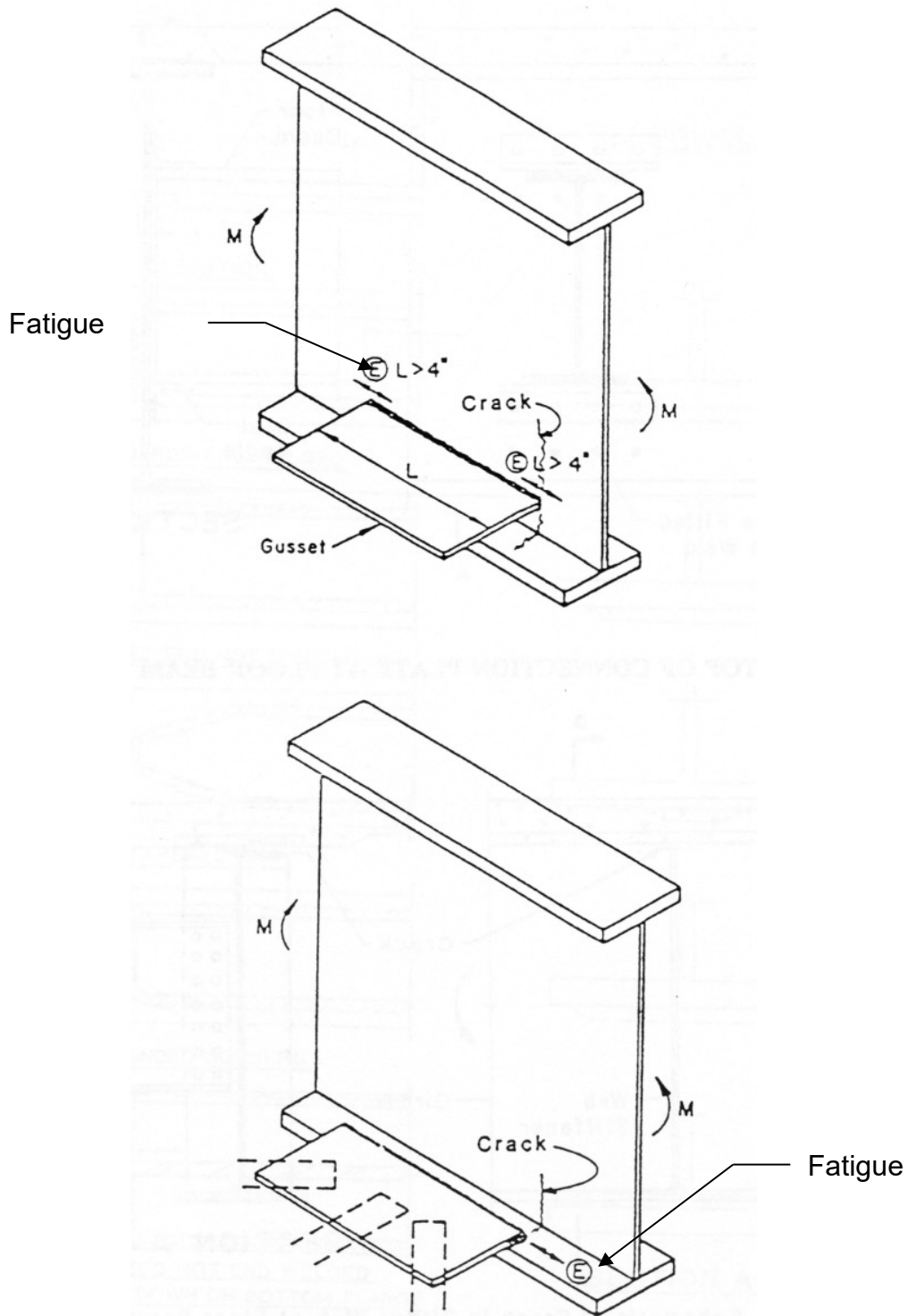

BRIDGE INSPECTION MANUAL

APPENDICES: BRIDGE INSPECTION

APPENDIX 5B: FRACTURE CRITICAL REPORT NARRATIVE TEMPLATE

Indiana Department of Transportation

FRACTURE CRITICAL REPORT

| | | |
|-----------------------|-------------------------|-----------------------------|
| Structure No.: | XXXXXXXXXX [NBI XXXXXX] | Date |
| of Inspection: | XX/XX/XXXX | |
| Road: | XXXXXXXXXX | Stream: XXXXXXXXXXXX |

This report template shall be prepared as a written report narrative that shall be titled "FRACTURE CRITICAL INSPECTION NOTES AND REPORT" and uploaded as a PDF to the BIAS inspection report sections for inclusion in the compiled BIAS inspection report. This report narrative shall contain the following:

1. Introduction discussing the following information:
 - Location and Description
 - Structure History
2. Field Inspection Operations
 - Members to be Inspected
 - Inspection Procedures
 - Equipment Required for Inspection
 - Bridge Cleaning Requirements
 - Traffic Maintenance Requirements
 - Other Items
3. Summary of inspection findings
4. Summary of recommendations: Summary shall include a discussion of rationale if a recommendation includes changing the inspection frequency.
5. Table of Fracture Critical Elements Inspection Findings (layout shown below)
6. Photographs (either attached to BIAS or part of the inspection report narrative) of select fracture critical members and connections including at least those:
 - rated '4' or less
 - not included in previous reports up to 10 years old
 - with cracks or other visible signs of structural distress

BRIDGE INSPECTION MANUAL

APPENDICES: BRIDGE INSPECTION

TABLE OF FRACTURE CRITICAL ELEMENTS INSPECTION FINDINGS

| SPAN | MEMBER | CONDITION RATING | FATIGUE CATEGORY | INSPECTION NOTES |
|-----------------|--|-----------------------------|--------------------------------|---|
| Span identified | Each FC member and connection shall have an individual row | NBI 58, 59, 60 rating scale | AASHTO fatigue category letter | Describe condition, defects, cracks, section remaining, or other noteworthy issues. |

BRIDGE INSPECTION MANUAL

APPENDICES: BRIDGE INSPECTION

APPENDIX 5C: FRACTURE CRITICAL WORK PLAN AND HAZARD ANALYSIS TEMPLATE

Note: The work plan and hazard analysis detailed in this Manual is intended for the fracture critical inspections of large multi-span bridges over major waterways. For state roads carried by smaller, single span bridges, or for county and local roads also carried by smaller, single span bridges, the work plan and hazard analysis is not required.

Indiana Department of Transportation

FRACTURE CRITICAL WORK PLAN AND HAZARD ANALYSIS

Structure No.: XXXXXXXXXXX [NBI XXXXXX] **Date of Inspection:** XX/XX/XXXX

Road: XXXXXXXXXXX **Stream:** XXXXXXXXXXX

This report template shall be prepared as a written report narrative that shall be titled “FRACTURE CRITICAL WORK PLAN AND HAZARD ANALYSIS” and uploaded as a PDF to the BIAS inspection report sections for inclusion in the compiled BIAS inspection report. This work plan shall include the following:

1. Name, address, and phone number of all emergency services (hospitals, fire department, etc.) and include approximate mileage and driving time from the bridge site.
2. On site bridge inspection personnel: names, employer, and mobile numbers.
Recommend identify members with special training certifications (CPP, SPRAT certification, etc.)
3. General Information regarding bridge to be inspected, speed limit on bridge and daily traffic counts (if known), and an inspection operations summary to include access equipment and traffic control/lane restrictions that will be used.
4. Safety equipment provided on site, to include PPE, communication tools, fall protection and fall restraint equipment, and first-aid kits.
5. Anticipated Hazards, including (but not limited to) the following.
 - Inspection vehicle hazards and planned means of rescue, including (but not limited to) man lift stuck in the up position, UB vehicle stuck in the down

BRIDGE INSPECTION MANUAL

APPENDICES: BRIDGE INSPECTION

deployed position, inspection vehicle dropping either a conscious or unconscious victim.

- Traffic hazards and planned mitigation (ie. Traffic control, work zones, flaggers, advanced notification to public via media).
 - Weather and Environmental hazards.
6. Planned daily inspection operations.

APPENDICES 6: FORMS

6A – Form - INITIAL SCOUR SCREENING PROCEDURE FOR LOCAL PUBLIC AGENCIES

6B – Form - SCOUR ASSESSMENT PROCEDURE FOR LOCAL PUBLIC AGENCIES

6C – Form - SCOUR ANALYSIS SUMMARY (HEC-18) FOR LOCAL PUBLIC AGENCIES

6D - MAP OF MODERATE RISK BRIDGES FOR USE WITH SCOUR EVALUATION PROCESS FOR LOCAL PUBLIC AGENCIES

6E – Form – BRIDGE SCOUR PLAN OF ACTION and BRIDGE SCOUR MONITORING LOG

APPENDIX 6A: INDIANA DEPARTMENT OF TRANSPORTATION INITIAL SCOUR SCREENING PROCEDURE FOR LOCAL PUBLIC AGENCIES

1. Is the bridge over a waterway? Yes/No
 - If No, complete the information at the bottom of this form and code Item 113 = “N”
 - If Yes, go to 2
2. Are all of the foundations on dry land well above flood water elevations or floodway? Yes/No
 - If Yes, complete the information at the bottom of this form and code Item 113 = “9”
 - If No **OR** Unknown, go to 3

BRIDGE INSPECTION MANUAL

APPENDICES: BRIDGE INSPECTION

3. Was the bridge designed and constructed to resist scour; and do plans show depth of foundation to be below the depth of Q100 scour (with sufficient length for friction piles)?
Yes/No or Unknown
 - If Yes, complete the information at the bottom of this form and code 113 = “8”
 - If Unknown, **OR** the foundations are not below the Q100, go to 4

4. Are spread footings on erosion resistant rock or pile foundations of sufficient depth (20') below scour with no signs or history of scour**? Yes/No
 - If Yes, complete the information at the bottom of this form and code Item 113 = “8”
 - If No **OR** Unknown, go to 5

5. Is the bridge a single span bridge that meets all following criteria? Yes/No
 - i. Appropriately sized scour countermeasures in place**, AND
 - ii. Elevation of stream bottom above bottom of footing/pile cap, AND
 - iii. Does not have any signs or history of scour
 - If Yes, complete the information at the bottom of this form and code Item 113 = “8”
 - If No, go to 6

6. Is the bridge a 4-Sided Box Culvert or a Pipe Culvert with no signs or history of scour?
Yes/No
 - If Yes, complete the information at the bottom of this form and code Item 113 = “8”
 - If No, go to 7

7. Is the bridge a single span concrete arch bridge with no signs or history of scour? Yes/No
 - If Yes, complete the information at the bottom of this form and code Item 113 = “8”
 - If No, complete the information at the bottom of this form, code “NA” on this form, and go to SCOUR ASSESSMENT PROCEDURES (Appendix B)

** See the “Definitions” section

To Be Completed by Scour Evaluator

Coding from INITIAL SCOUR SCREENING PROCEDURE: NA OR Item 113 = N, 9, 8

Coding by Scour Evaluator: NA OR Item 113 = N, 9, 8

Justification if different:

County:

County Bridge#:

NBI

Bridge # Screening performed by:

Signed:

Date:

BRIDGE INSPECTION MANUAL

APPENDICES: BRIDGE INSPECTION

APPENDIX 6B: INDIANA DEPARTMENT OF TRANSPORTATION SCOUR ASSESSMENT PROCEDURE FOR LOCAL PUBLIC AGENCIES

1. CULVERTS: Is the bridge a 4-sided box culvert or a pipe culvert?
 - If Yes, go to 9.
 - If No, go to 2.a

2. HISTORICAL SCOUR PERFORMANCE:
 - a. Has the bridge experienced a flood with a documented 100 yr. return interval which did not result in significant scour?
 - Yes, assign a rating of "8" to Scour Critical Evaluation Rating (Item 113)
 - No, go to 2.b
 - Unknown, go to 2.b

 - b. Is the bridge >50 years old with no signs or history of scour and not on granular or soft soil?
 - Yes, assign a rating of "8" to Scour Critical Evaluation Rating (Item 113)
 - No, go to 3
 - Unknown, go to 3

3. SCOUR COUNTERMEASURES:
 - a. Are scour countermeasures in place, functioning properly, and have minor to no damage?
 - Yes, go to 3.b
 - No, go to 4
 - Unknown, go to 4

 - b. Are the scour countermeasures appropriately sized?
 - Yes, go to 3.c
 - No, go to 4
 - Unknown, go to 4

 - c. Has the bridge experienced a flood with a documented 50-year return interval with no damage to the installed countermeasures?
 - Yes, go to 3.d

BRIDGE INSPECTION MANUAL

APPENDICES: BRIDGE INSPECTION

- No, go to 4
 - Unknown, go to 3.d
- d. If scour countermeasures are present, were they installed to correct a previously existing problem with scour?
- Yes, assign a rating of "7" to Scour Critical Evaluation Rating (Item 113)
 - No, assign a rating of "8" to Scour Critical Evaluation Rating (Item 113)
 - Unknown, assign a rating of "8" to Scour Critical Evaluation Rating (Item 113)
4. GEOMORPHIC CONDITIONS AFFECTING SCOUR RESISTANCE:
- a. Is the stream bed degrading?
- Yes, go to 7
 - No, go to 4.b
 - Unknown, go to 7
- b. Is the channel meandering?
- Yes, go to 7
 - No, go to 4.c
 - Unknown, go to 7
- c. For natural streams, are there channel bends of greater than 30 degrees within 100 feet upstream of the bridge?
- Yes, go to 7
 - No, go to 4.d
 - Unknown, go to 7
- d. Are the stream banks unstable?
- Yes, go to 7
 - No, go to 4.e
 - Unknown, go to 7
- e. Are bridge substructure units skewed from the direction of flow?
- Yes, go to 7
 - No, go to 4.f
 - Unknown, go to 7
- f. Do ice jams or debris block more than 10% of the flow cross section?
- Yes, go to 7
 - No, go to 5
 - Unknown, go to 7
5. SINGLE SPAN BRIDGE CONSIDERATIONS:
- a. Is the bridge is multiple-span?

BRIDGE INSPECTION MANUAL

APPENDICES: BRIDGE INSPECTION

- Yes, go to 6
 - No, go to 5.b
- b. Is the bridge a single span and the Waterway Adequacy (NBI Item 71) is greater than 5
- Yes, go to 5.c
 - No, go to 6
- c. Is the bridge supported by concrete abutments on piles?
- Yes, assign a rating of “8” to Scour Critical Evaluation Rating (Item 113)
 - No, go to 5.d
 - Unknown, go to 5.d
- d. Is the bridge supported by timber abutment on piles?
- Yes, assign a rating of “8” to Scour Critical Evaluation Rating (Item 113)
 - No, go to 5.e
 - Unknown, go to 5.e
- e. Is the bridge supported by end bent on piles with a spillslope at each end bent?
- Yes, assign a rating of “8” to Scour Critical Evaluation Rating (Item 113)
 - No, go to 5.f
 - Unknown, go to 5.f
- f. Is the bridge on concrete abutments?
- Yes, go to 5.g
 - No, go to 5.h
 - Unknown, go to 6
- g. Is the bridge over a waterway labeled as a “Ditch”?
- Yes, assign a rating of “8”
 - No, go to 5.h
 - Unknown, go to 5.h
- h. Does the waterway have a slope of less than 0.5 feet per mile?
- Yes, assign a rating of “8” to Scour Critical Evaluation Rating (Item 113)
 - No, go to 6
 - Unknown, go to 6

BRIDGE INSPECTION MANUAL

APPENDICES: BRIDGE INSPECTION

6. REDUCED RISK BRIDGES:

- a. Is the bridge programmed for replacement or rehabilitation within 5 years
 - Yes, go to 6.c
 - No, go to 6.b
 - Unknown, go to 6.b

- b. Is the bridge programmed to receive an installation of scour countermeasures within 2 years?
 - Yes, go to 6.c
 - No, go to 6.d
 - Unknown, go to 6.d

- c. Does the bridge have any signs or significant history of scour?
 - Yes, go to 7
 - No, assign a rating of “5” to Scour Critical Evaluation Rating (Item 113).
 - Unknown, go to 7

- d. Is the road classified as a "Rural Minor Collector or Local Road" (Item 26 - Functional Classification of Rural Minor Collector or Local)
 - Yes, go to 6.e
 - No, go to 7
 - Unknown, go to 7

- e. Is the estimated average daily traffic (ADT) over the bridge less than 200?
 - Yes, assign a rating of “5” to Scour Critical Evaluation Rating (Item 113).
 - No, go to 7
 - Unknown, go to 7

7. FOUNDATIONS ON SPREAD FOOTINGS SCOUR RESISTANCE ASSESSEMENT: If the foundation is unknown, and the pile length cannot be reasonably assured, then treat the bridge as if it is supported on spread footing

- a. Is the bridge supported on spread footings?
 - Yes, go to 7.b
 - No, go to 8
 - Unknown, treat it as spread footing and go to 7.b

- b. Is the spread footing on rock?
 - Yes, go to 7.c
 - No, go to 7.j

BRIDGE INSPECTION MANUAL

APPENDICES: BRIDGE INSPECTION

- Unknown, treat as granular or soft soil, go to 7.q

All of the following questions (7.c through 7.i) assume that the spread footing is on ROCK

- c. ...and footing socketed into rock, regardless of exposure?
 - Yes, assign a rating of "8"
 - No, go to 7.d
- d. ...and top of footing is not exposed?
 - Yes, assign a rating of "8"
 - No, go to 7.e
- e. ...and the top of footing is exposed?
 - Yes, assign a rating of "5"
 - No, go to 7.f
- f. ...and the footing is fully exposed with no rock degradation?
 - Yes, assign a rating of "4"
 - No, go to 7.g
- g. ... and the footing is fully exposed with rock degradation and less than 10% undermining?
 - Yes, assign a rating of "3"
 - No, go to 7.h
- h. ...and the footing is fully exposed with rock degradation and more than 10% undermining?
 - Yes, go to 7.i
- i. ...and failure is eminent?
 - Yes, assign a rating of "1" – Close the Bridge
 - No, assign a rating of "2" – Create Critical Finding
- j. Is the spread footing on stiff clays/clay till ($Q_u > 1.5$ tsf)
 - Yes, go to 7.k
 - No, go to 7.q
 - Unknown, treat as granular or soft soil, go to 7.q

All of the following questions (7.k through 7.p) assume that the spread footing is on stiff clays/clay till ($Q_u > 1.5$ tsf).

- k. ...and no observed scour?
 - Yes, assign to rating of, "5"

BRIDGE INSPECTION MANUAL

APPENDICES: BRIDGE INSPECTION

- No, go to 7.l
- l. ...and scour present and the footing not exposed?
 - Yes, assign a rating of "5"
 - No, go to 7.m
- m. ...and scour present, $< \frac{1}{2}$ of the top of the footing exposed and determined to be stable?
 - Yes, assign a rating of "4"
 - No, go to 7.n
- n. ...and scour present, $> \frac{1}{2}$ of the top of the footing exposed?
 - Yes, less than 10% of footing undermined, assign a rating of "3"
 - Yes, scour is adjacent to less than 25% of the face of the footing (below footing), assign a rating of "3"
 - No, go to 7.o
- o. ...and scour present and $> \frac{1}{2}$ of footing exposed and determined unstable?
 - Yes, 10% or more of the footing is undermined, go to 7.p
 - Yes, Scour is adjacent to more than 25% of the face of footing, go to 7.p
- p. ...and failure is eminent?
 - Yes, assign a rating of "1" – Close the Bridge
 - No, assign a rating of "2" – Create Critical Finding

All of the following questions (7.q through 7.u) assume that the spread footing on granular or soft soils ($Q_u < 1.5$ tsf).

- q. Is there any observed scour on the spread footing?
 - Yes, go to 7.r
 - No, assign a rating of "5"
- r. Scour present, however the footing is not exposed?
 - Yes, assign a rating of "4"
 - No, go to 7.s
- s. Scour present and the footing exposed with less than 10% scour to the face of the footing?
 - Yes, assign a rating of "3"
 - No, go to 7.t
- t. Scour present and the footing exposed with more than 10% scour to the face of the footing (below footing) or otherwise considered unstable?

BRIDGE INSPECTION MANUAL

APPENDICES: BRIDGE INSPECTION

- Yes, go to 7.u
- u. Is failure of the spread footing eminent?
 - Yes, assign a rating of "1" – Close the Bridge
 - No, assign a rating of "2" – Create Critical Finding
- 8. FOUNDATIONS ON PILES SCOUR RESISTANCE ASSESSEMENT: If the foundation is unknown, and the pile length cannot be reasonably assured, then treat the bridge as if it is supported on spread footing.
 - a. Is the bridge supported on Pile Foundations?
 - Yes, go to 8.b
 - No, go to 7.a
 - Unknown, go to 7.a

All of the following questions (8.b through 8.p) assume that the bridge has a pile foundation.

- b. For any soil type, are the pile tips $\geq 40'$ below ground surface and piles not exposed by significant scour?
 - Yes, assign a rating of "8".
 - No, go to 8.c
- c. Are the piles socketed or driven into rock not exposed by "significant" scour?
 - Yes, assign a rating of "8"
 - No, go to 8.d
- d. Are the piles socketed or driven into rock and exposed by "significant" scour?
 - Yes, assign a rating of "5"
 - No, go to 8.e
- e. Are the bridge pile tips on rock but not socketed or driven into rock?
 - Yes, go to 8.f
 - No, go to 8.j

All of the following questions (8.f through 8.j) assume that the bridge has a pile foundation where the tips are on rock but not socketed or driven into rock.

- f. ...and has minor/no existing scour present or has occurred previously with a 3-foot minimum thickness of cohesive soil in upper $\frac{1}{2}$ of embedded pile length?
 - Yes, assign a rating of "8"
 - No, go to 8.g
- g. ...and has minor/no existing scour present or has occurred previously with no layers of cohesive soil in upper $\frac{1}{2}$ of embedded pile length?
 - Yes, assign a rating of "5"
 - No, go to 8.h
- h. ...and has observed scour or erosion with a 3-foot minimum thickness of cohesive soil in upper $\frac{1}{2}$ of embedded pile length?

BRIDGE INSPECTION MANUAL

APPENDICES: BRIDGE INSPECTION

- Yes, assign a rating of "4"
- No, go to 8.i
- i. ... and has no observed scour but a history of significant scour or erosion with no layers of cohesive soil in upper $\frac{1}{2}$ of embedded pile length?
 - Yes, assign a rating of "3"
 - No, go to 8.j
- j. and has observed significant scour with no layers of cohesive soil in upper $\frac{1}{2}$ of embedded pile length?
 - Yes, assign a rating of "2"
 - No, go to 8.k
- k. Are the bridge piles, friction piles in cohesive soils?
 - Yes, go to 8.l
 - No, assign a rating of "2"

All of the following questions (8.k through 8.r) assume that the bridge has a pile foundation are friction piles in cohesive soils.

- l. ... and a minimum 3-ft layer w/ $Q_u > 1.5$ tsf in upper $\frac{1}{2}$ of embedded pile length required, where minor/no existing scour is present or has occurred previously with Pile tips $\geq 15'$ deep?
 - Yes, assign a rating of "8"
 - No, go to 8.m
- m. ...and a minimum 3-ft layer w/ $Q_u > 1.5$ tsf in upper $\frac{1}{2}$ of embedded pile length required, where minor/no existing scour is present or has occurred previously with Pile tips $< 15'$ deep?
 - Yes, assign a rating of "5"
 - No go to 8.n
- n. ...and a minimum 3-ft layer w/ $Q_u > 1.5$ tsf in upper $\frac{1}{2}$ of embedded pile length required with a history of significant scour/erosion with Pile tips $\geq 35'$ deep?
 - Yes, assign a rating of "8"
 - No, go to 8.o
- o. ...and a minimum 3-ft layer w/ $Q_u > 1.5$ tsf in upper $\frac{1}{2}$ of embedded pile length required with a history of significant scour/erosion with Pile tips $< 35'$ and $\geq 20'$ deep
 - Yes, assign a rating of "5"
 - No, go to 8.p
- p. ...and a minimum 3-ft layer w/ $Q_u > 1.5$ tsf in upper $\frac{1}{2}$ of embedded pile length required with a history of significant scour/erosion with Pile tips $< 20'$ deep without significant scour present
 - Yes, assign a rating of "4"
 - No, go to 8.q
- q. ...and a minimum 3-ft layer w/ $Q_u > 1.5$ tsf in upper $\frac{1}{2}$ of embedded pile length required with a history of significant scour/erosion with Pile tips $< 20'$ deep with significant scour present but determined stable?

BRIDGE INSPECTION MANUAL

APPENDICES: BRIDGE INSPECTION

- Yes, assign a rating of “3”
 - No, go to 8.r
 - r. ...and a minimum 3-ft layer w/ $Q_u > 1.5$ tsf in upper $\frac{1}{2}$ of embedded pile length required with a history of significant scour/erosion with pile tips $< 20'$ deep with significant scour present or piles otherwise determined unstable?
 - Yes, go to 8.s
 - s. Is failure of the pile eminent?
 - Yes, assign a rating of "1" – Close the Bridge
 - No, assign a rating of "2" – Create Critical Finding
9. CULVERT (STRUCTURES UNDER FILL)
- a. What is the shape of the culvert?
 - Box
 - Pipe
 - b. Does the culvert have significant scour behind the ends of the box and the cut-off walls due to undermining of the wingwalls?
 - Yes, go to 9.b.i
 - No, go to 9.c
 - Unknown, go to 9.c
 - i. Is the stream bed degrading?
 - Yes, assign rating of “4”
 - No, go to 9.b.ii
 - Unknown, assign rating of “4”
 - ii. Is the channel meandering?
 - Yes, assign rating of “4”
 - No, go to 9.b.iii
 - Unknown, assign rating of “4”
 - iii. For natural streams, are there channel bends of greater than 30 degrees within 100 feet upstream of the bridge?
 - Yes, assign rating of “4”
 - No, go to 9.b.iv
 - Unknown, assign rating of “4”

BRIDGE INSPECTION MANUAL

APPENDICES: BRIDGE INSPECTION

- iv. Are the stream banks unstable?
 - Yes, assign rating of “4”
 - No, assign rating of “5”
 - Unknown, assign rating of “4”
- c. Does the culvert have scour adjacent to the cut-off walls?
 - Yes, go to 9.c.i
 - No, assign rating of “5”
 - Unknown, go to 9.c.i
- i. Is the stream bed degrading?
 - Yes, assign rating of “2”
 - No, go to 9.c.ii
 - Unknown, assign rating of “2”
- ii. Is the channel meandering?
 - Yes, assign rating of “2”
 - No, go to 9.c.iii
 - Unknown, assign rating of “2”
- iii. For natural streams, are there channel bends of greater than 30 degrees within 100 feet upstream of the bridge?
 - Yes, assign rating of “2”
 - No, go to 9.c.iv
 - Unknown, assign rating of “2”
- iv. Are the stream banks unstable?
 - Yes, assign rating of “2”
 - No, assign rating of “3”
 - Unknown, assign rating of “2”

BRIDGE INSPECTION MANUAL

APPENDICES: BRIDGE INSPECTION

To Be Completed by Scour Evaluator

**Scour Critical Evaluation Rating (Item 113) from SCOUR ASSESSMENT PROCEDURE:
8, 7, 5, 4, 3, 2, 1**

Scour Critical Evaluation Rating (Item 113) by Scour Evaluator: 8, 7, 5, 4, 3, 2, 1

Justification if different:

County: _____ **County Bridge#:** _____ **NBI**

Bridge # Foundation type:

Assessment performed by:

Signed:

Date:

BRIDGE INSPECTION MANUAL

APPENDICES: BRIDGE INSPECTION

APPENDIX 6C: INDIANA DEPARTMENT OF TRANSPORTATION SCOUR ANALYSIS SUMMARY (HEC-18) FOR LOCAL PUBLIC AGENCIES

The scour analysis will be completed using HEC-RAS in accordance with HEC-18 and the INDOT Design Manual. Only Q100 will be used for the analysis. A summary of the scour parameters from the HEC-18 analysis will be uploaded to the bridge file (see below). A determination of the proper Coding for Item 113 will be made following the FHWA coding guide.

Scour Parameters

| | | |
|-------------------------|---|----------|
| Q100 Discharge | = | cfs. |
| Elevation @ Q100 | = | MSL |
| Velocity @ Q100 | = | ft./sec. |
| Contraction Scour Depth | = | ft. |
| Total Scour Depth | = | ft. |
| Low Scour Elevation | = | MSL |

To Be Completed by Scour Evaluator

**Scour Critical Evaluation Rating (Item 113) from SCOUR ASSESSMENT PROCEDURE:
8, 7, 5, 4, 3, 2, 1**

**Scour Critical Evaluation Rating (Item 113) by Scour Evaluator: 8, 7, 5, 4, 3, 2,
1 Justification if different:**

County: _____ **County Bridge#:** _____ **NBI**

Bridge # Foundation type:

Assessment performed by:

Signed:

Date:

BRIDGE INSPECTION MANUAL

APPENDICES: BRIDGE INSPECTION

APPENDIX 6D: INDIANA DEPARTMENT OF TRANSPORTATION MAP OF MODERATE RISK BRIDGES FOR USE WITH SCOUR EVALUATION PROCESS FOR LOCAL PUBLIC AGENCIES



BRIDGE INSPECTION MANUAL

APPENDICES: BRIDGE INSPECTION

APPENDIX 6E: BRIDGE SCOUR PLAN OF ACTION

Indiana Department of Transportation

Bridge Scour Plan of Action

Structure No.:

Date:

Triggering Event for Monitoring and Frequency:

Monitoring Plan:

Closure Plan:

Closure Notification:

Emergency Management Director: XXX (District Deputy Commissioner) XXX-XXX-XXXX

Highway Engineer/Supervisor: XXX (Highway Maintenance Director) XXX-XXX-XXXX

Bridge Inspection: XXX (District Bridge Inspection Engineer) XXX-XXX-XXXX
or XXX (Bridge Inspection Area Engineer) XXX-XXX-XXXX

Reopening Inspection Requirements:

Written by: XXX, District Bridge Inspection Engineer

Signed: _____

Date: _____

Approved By: _____

Date: _____

