



INDIANA DEPARTMENT OF TRANSPORTATION

100 North Senate Avenue

Room N758

Indianapolis, Indiana 46204-2216

(317) 232-5533

FAX: (317) 232-0238

An Equal Opportunity Employer • <http://www.in.gov/dot>

MITCHELL E. DANIELS, JR., Governor

THOMAS O. SHARP, Commissioner

Writer's Direct Line

March 6, 2006

MEMORANDUM

06-02

TO: District Directors
District Construction Engineers
Toll Road Operations Engineer
District Materials & Tests Engineers
District Area Engineers
Project Engineers/Supervisors

FROM: Mark A. Miller, Director
Division of Construction Management

A handwritten signature in black ink, appearing to read "Mark A. Miller", is written over the typed name. Below the signature, the initials "MAM" are written.

Subject: Fabrication Detail of Expansion Joints Class SS

It has come to the Department's attention that there is potential for some SS expansion joints to be supplied to INDOT contracts that may not meet INDOT Standards. In addition, the shop drawings supplied for the suspect SS joints may comply with INDOT Standards but not accurately reflect the actual fabrication. This could result in shop drawings being approved for joints that should not be installed in an INDOT contract.

The Division of Construction Management is responsible for checking shop drawings submitted by the fabricator for conformance with the Standards. The Division will distribute approved shop drawings. The PE/PS must check the approved shop drawings against the material delivered to the job site to ensure that only approved SS joints are incorporated into the contract.

Attached is a detail from the approved INDOT Standards along with a sketch of an unacceptable detail. The applicable Standards for SS joints are 724-BSSJ-01 thru 724-BSSJ-09.

MAM:rlh

attachment

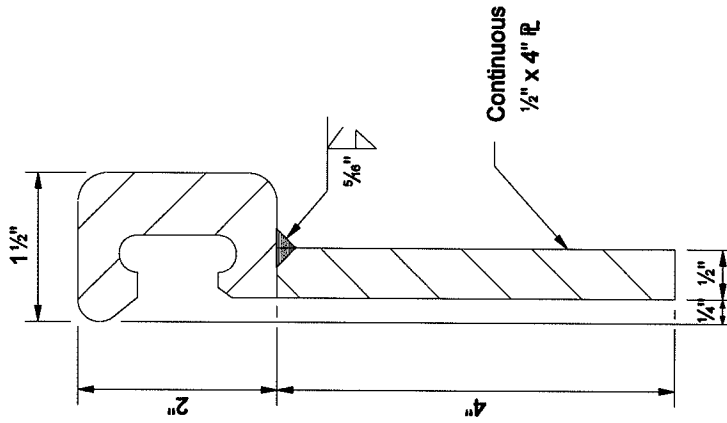

STANDARD EXTRUSION & PLATE
ASSEMBLY DETAIL

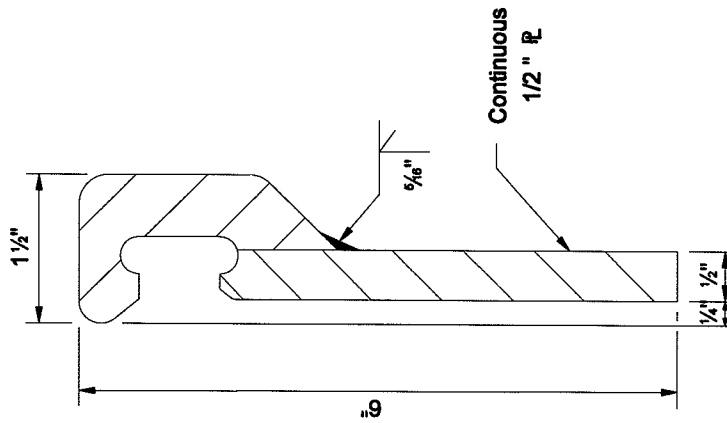

UNAPPROVED
ASSEMBLY DETAIL