

VARIOUS  
COUNTIES

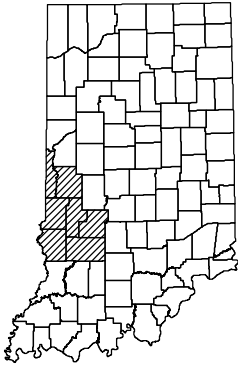

STATE OF INDIANA  
INDIANA DEPARTMENT OF NATURAL RESOURCES  
DIVISION OF RECLAMATION



ABANDONED COAL MINE  
RESTORATION

NORTHERN MAINTENANCE  
VARIOUS SITES

CONTRACT DEL2115208379/E009-230  
CLAY, GREENE, SULLIVAN, PARKE, OWEN,  
VERMILLION, AND VIGO COUNTIES

SCOPE OF WORK INCLUDES:  
DITCH CONSTRUCTION  
SEEP DRAIN CONSTRUCTION  
SUBSIDENCE FILL

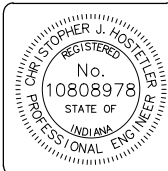

CERTIFIED BY: *Christopher J. Hostetler* 2/23/2021  
ENGINEERING SUPERVISOR DATE

APPROVED BY: *[Signature]* 2/23/2021  
DIRECTOR, DIVISION OF RECLAMATION DATE

## GENERAL NOTES

2010 AML Standard Specifications shall be used with this project

Erosion control blanket, riprap, aggregate, and other materials placed in ditches as directed will be paid for separately in accordance with the schedule of supplemental unit prices.

## INDEX

SHEET NO.	SHEET TITLE
1	TITLE
2	INDEX & LOCATION MAP
3	WORK ORDER
4 - 8	DETAILS

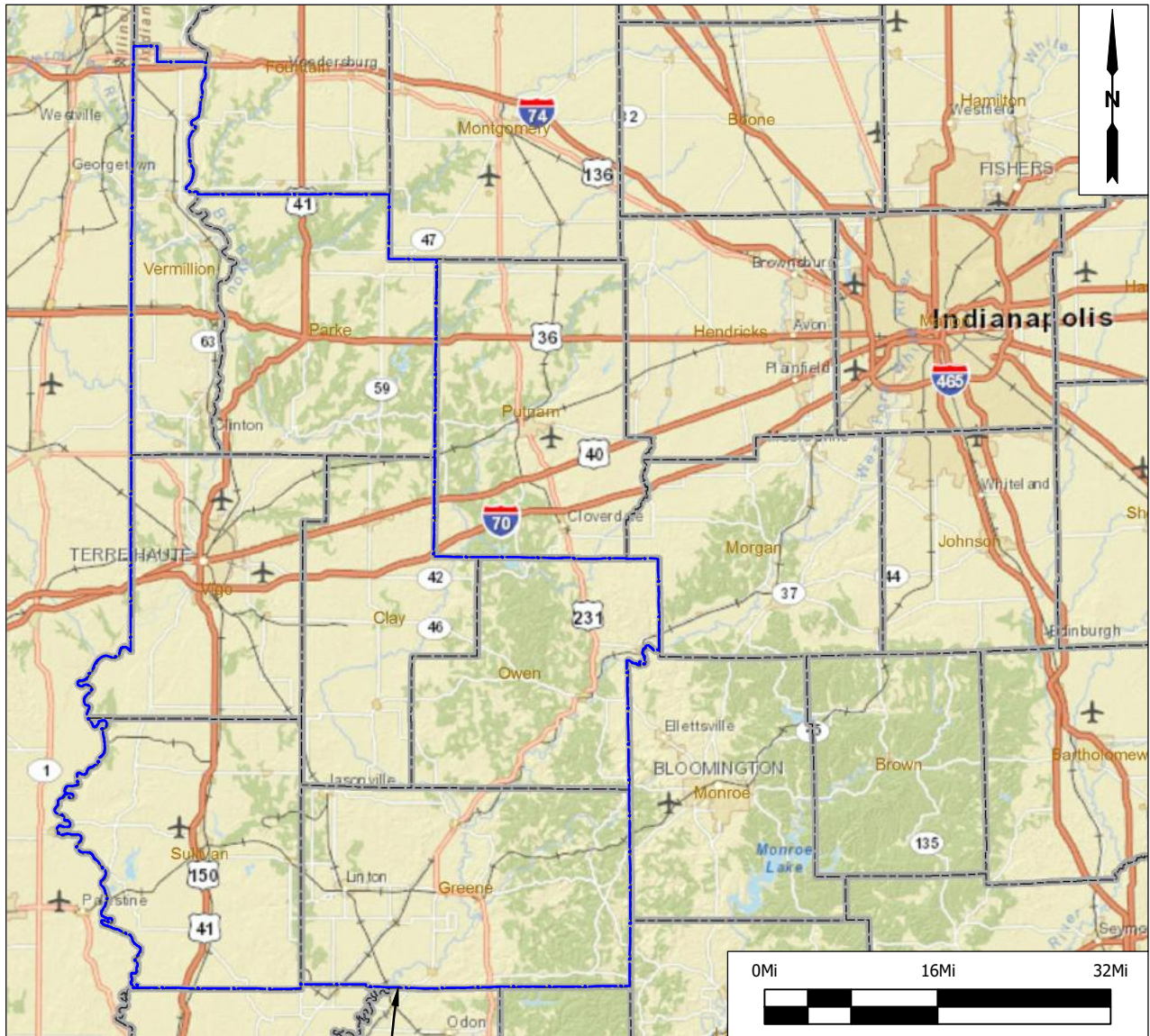

UPC North

### Location Map

OpenStreetMap©



DATE MADE

2/8/2021

INDEX & LOCATION MAP

DESIGNED BY

C.J.H.

SCALE

AS NOTED

SHEET

2 OF 8

DATE REVISED

2/8/2021 3:27:52 PM

STATE OF INDIANA  
DEPARTMENT OF NATURAL RESOURCES  
DIVISION OF RECLAMATION

DRAWN BY

C.J.H.

PROJECT

E009-230

SITE

VARIOUS



### Type I Ditch

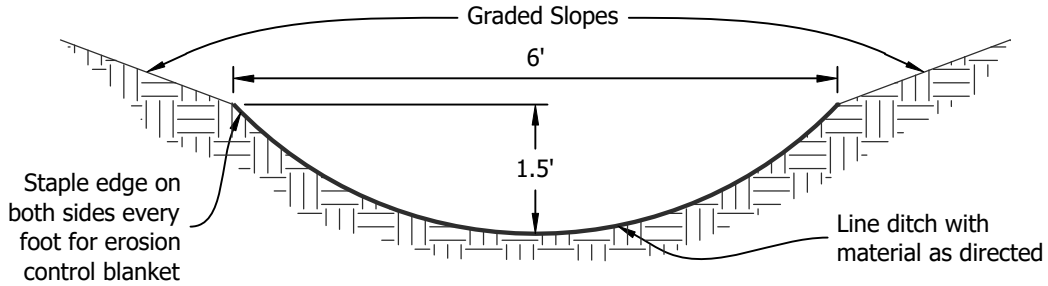

### Type II Ditch

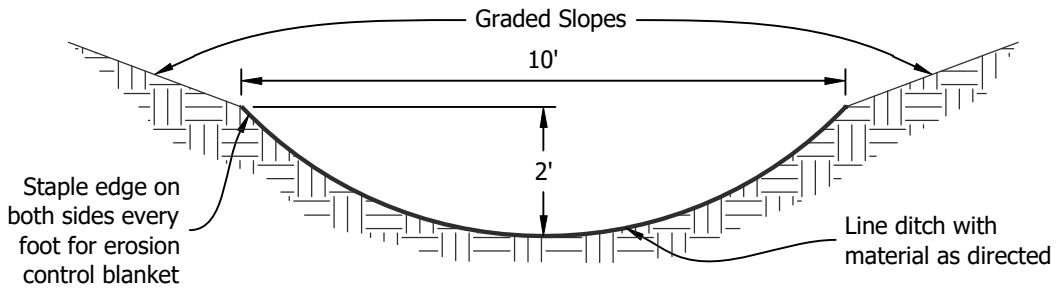

### Type III Ditch

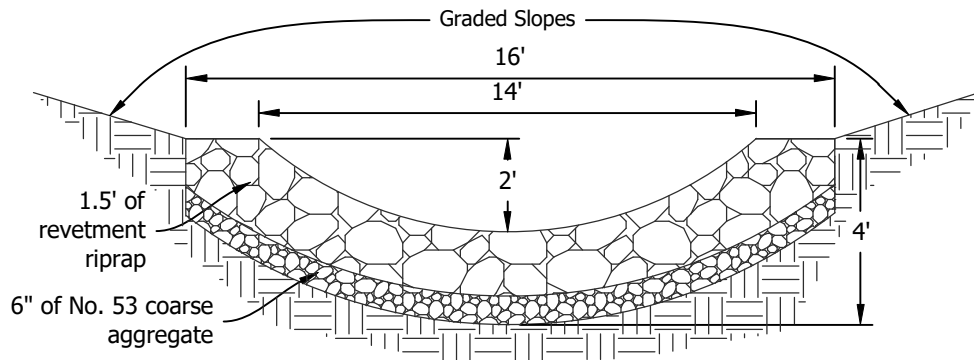

### Type IV Ditch

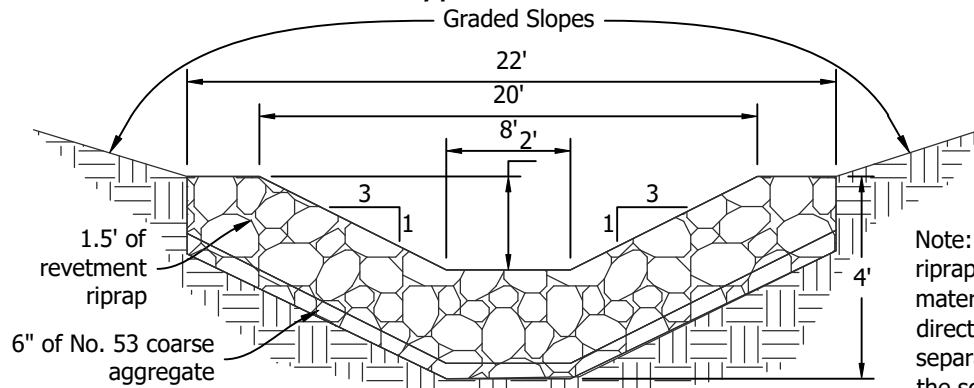

Note: Erosion control blanket, riprap, aggregate, and other materials placed in ditches as directed will be paid for separately in accordance with the schedule of supplemental unit prices.



DATE MADE  
2/8/2021

DETAILS - DITCH TYPES

DESIGNED BY  
C.J.H.

SCALE  
NOT TO SCALE

SHEET  
4 OF 8

DATE REVISED  
2/8/2021 3:27:52 PM

STATE OF INDIANA  
DEPARTMENT OF NATURAL RESOURCES  
DIVISION OF RECLAMATION

DRAWN BY  
C.J.H.

PROJECT  
E009-230

SITE  
VARIOUS

## Temporary Check Dam, Straw Bale

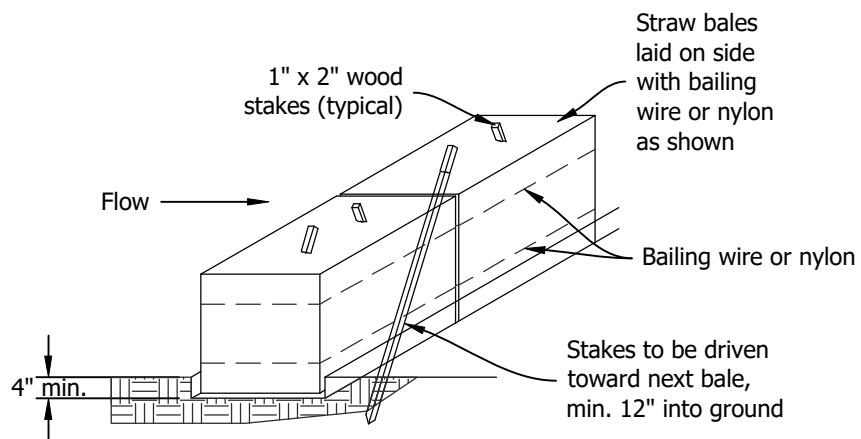

DATE MADE  
2/8/2021

DETAILS - TEMPORARY CHECK DAM,  
STRAW BALES

DESIGNED BY  
C.J.H.

SCALE  
NOT TO SCALE

SHEET  
5 OF 8

DATE REVISED  
2/8/2021 3:27:52 PM

STATE OF INDIANA  
DEPARTMENT OF NATURAL RESOURCES  
DIVISION OF RECLAMATION

DRAWN BY  
C.J.H.

PROJECT  
E009-230

SITE  
VARIOUS

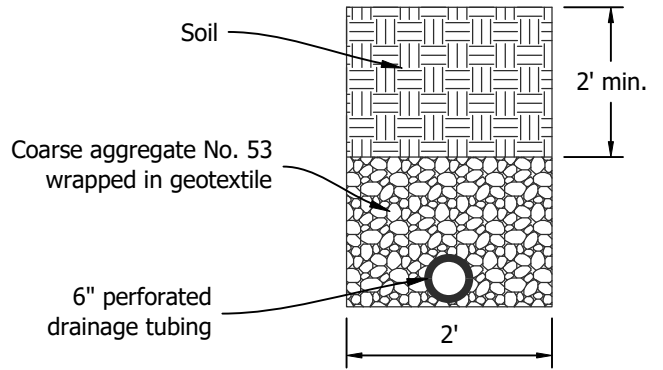
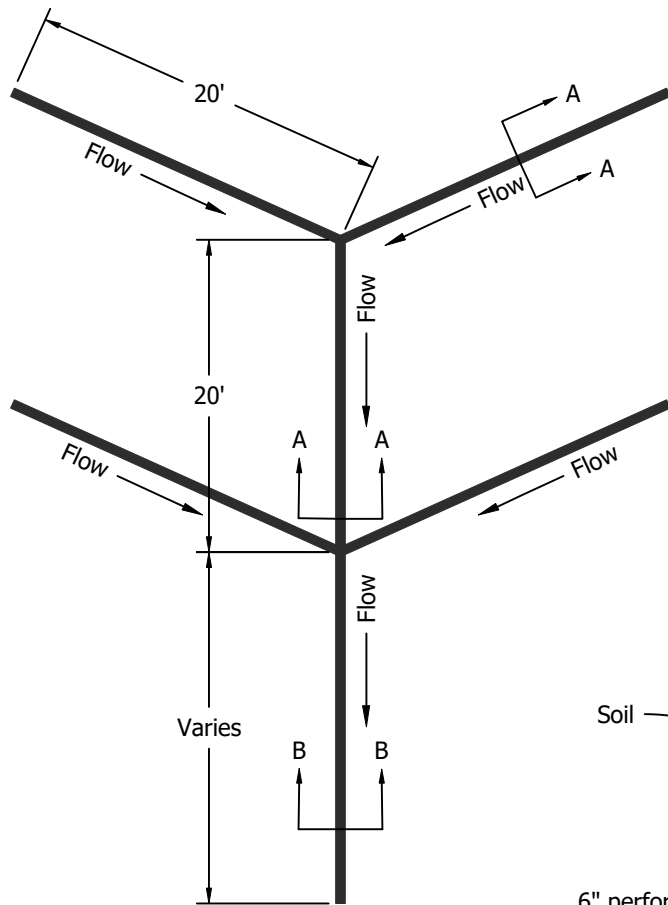

Lateral Detail  
A-A

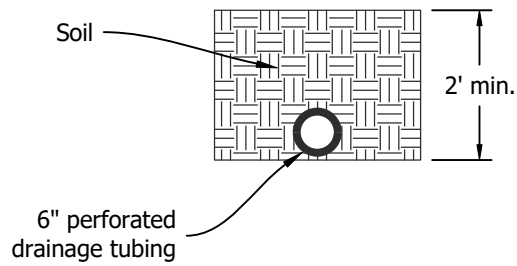

Collection Pipe  
B-B



DATE MADE  
2/8/2021

DATE REVISED  
2/8/2021 3:27:52 PM

DETAILS - TILE DRAIN

STATE OF INDIANA  
DEPARTMENT OF NATURAL RESOURCES  
DIVISION OF RECLAMATION

DESIGNED BY  
C.J.H.

DRAWN BY  
C.J.H.

SCALE  
NOT TO SCALE

PROJECT  
E009-230

SHEET  
6 OF 8

SITE  
VARIOUS

## Typical Subsidence Backfill Type A

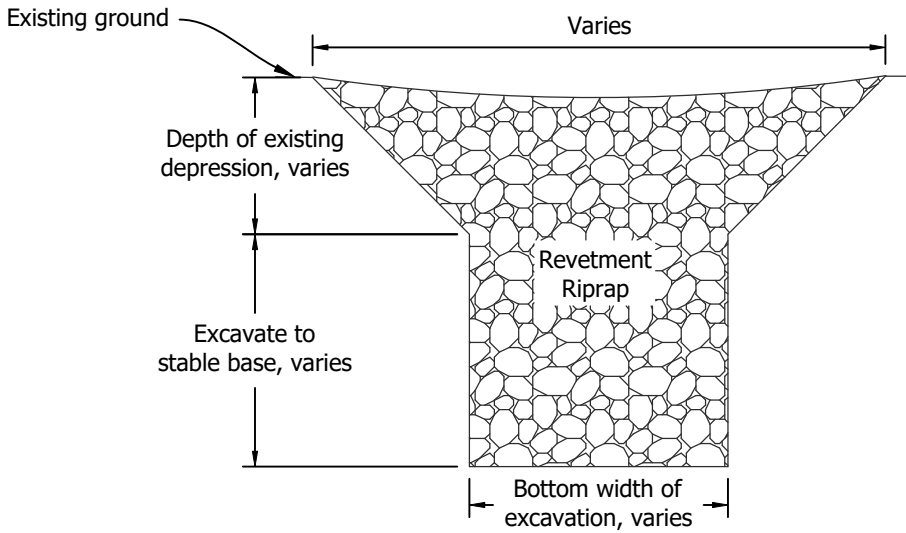

## Typical Subsidence Backfill Type B

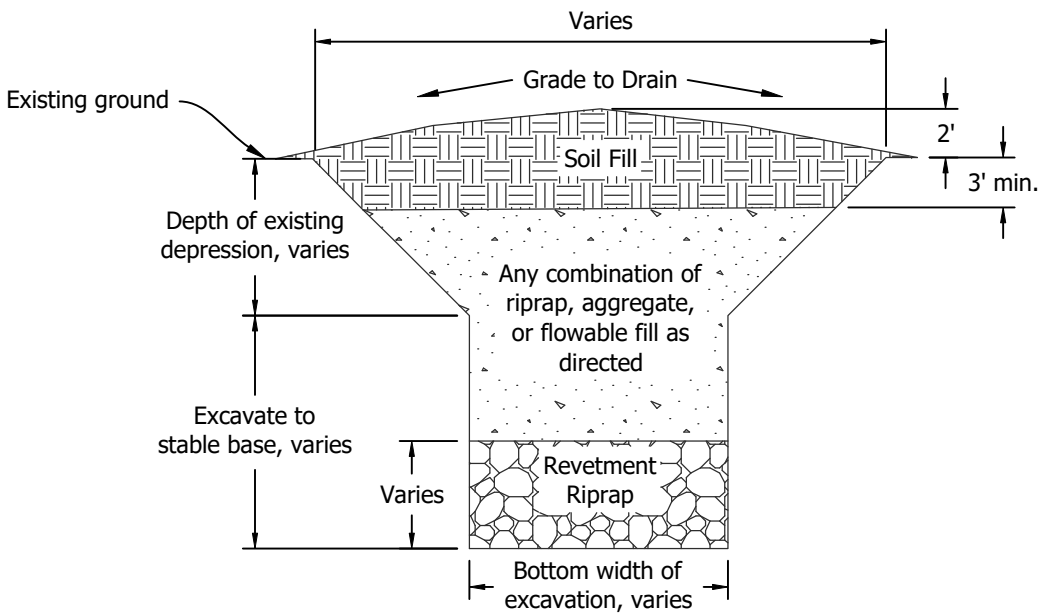

DATE MADE  
2/8/2021

DATE REVISED  
2/8/2021 3:27:52 PM

DETAILS - SUBSIDENCE BACKFILL

STATE OF INDIANA  
DEPARTMENT OF NATURAL RESOURCES  
DIVISION OF RECLAMATION

DESIGNED BY  
C.J.H.

DRAWN BY  
C.J.H.

SCALE  
NOT TO SCALE

PROJECT  
E009-230

SHEET  
7 OF 8

SITE  
VARIOUS

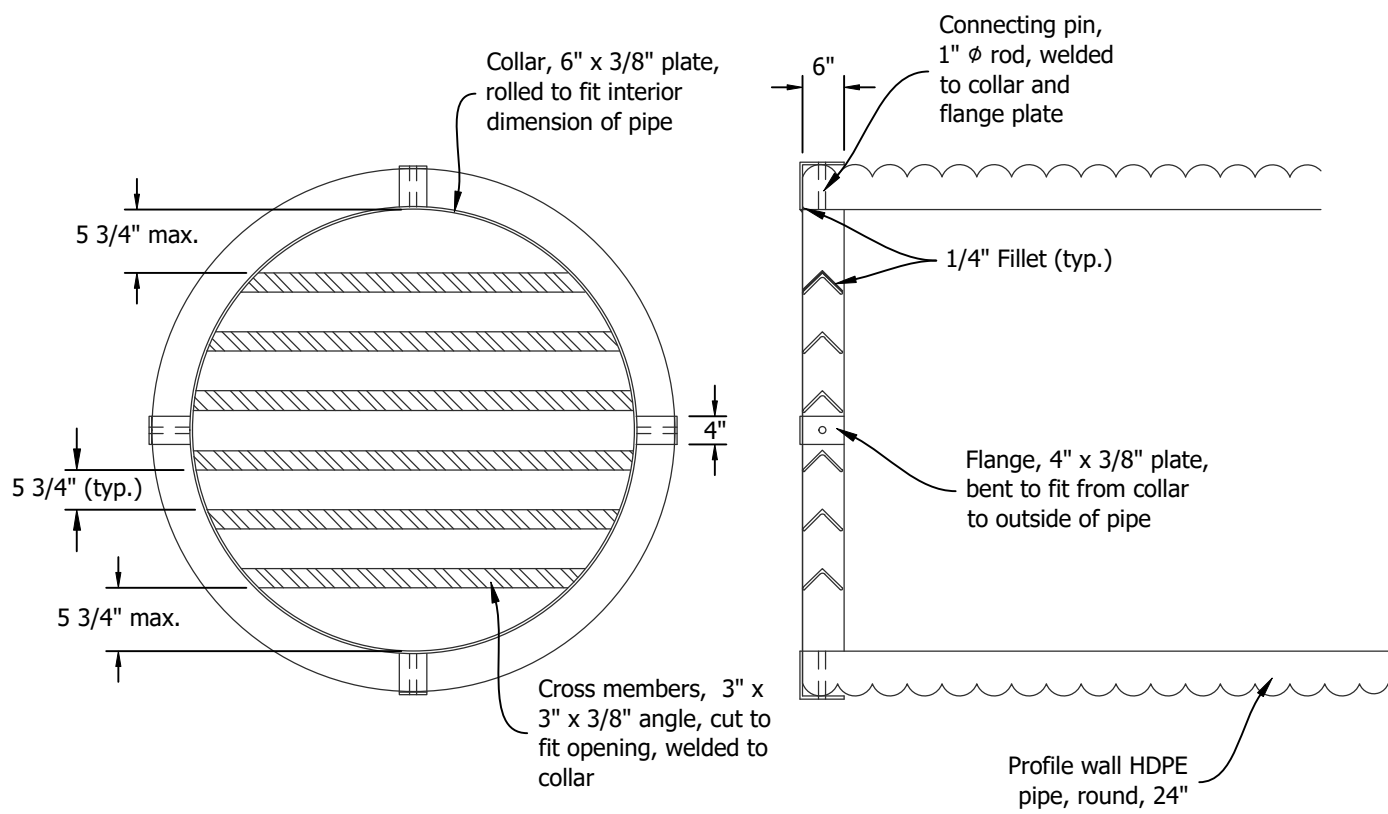
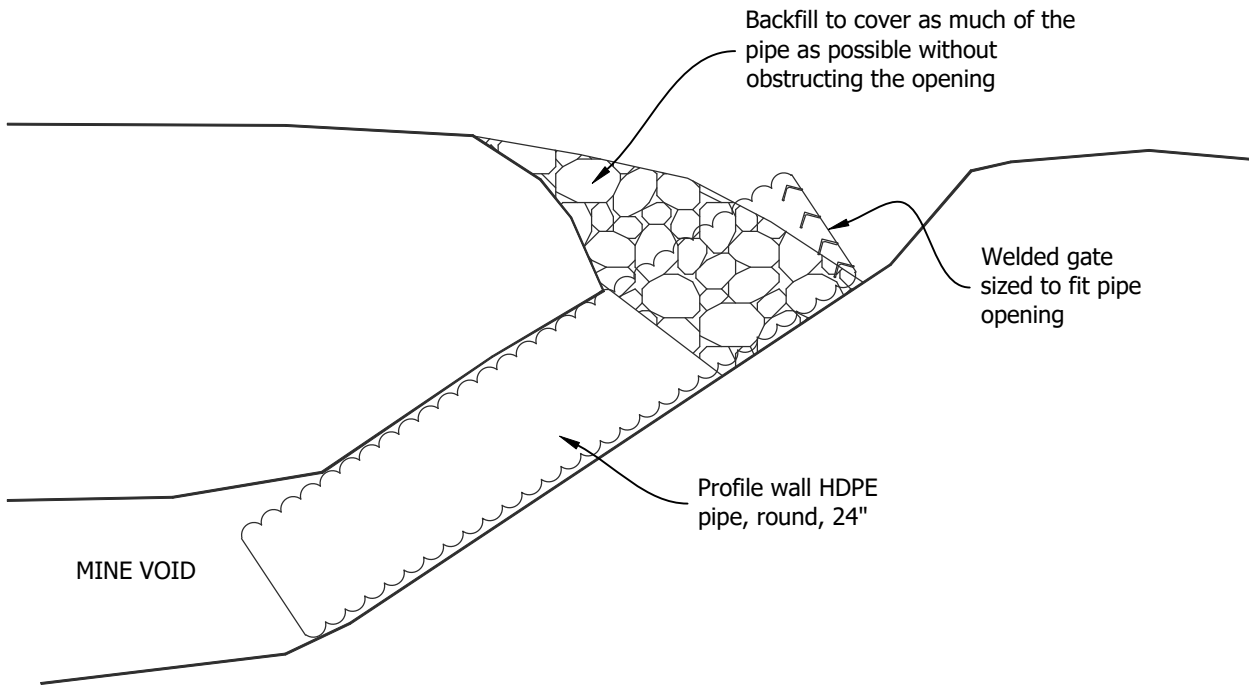

Note: Entire welded gate shall be cleaned and painted with rust inhibiting primer, then top coated with high quality enamel paint (black or brown) prior to installation.



DATE MADE  
2/8/2021

DETAILS - CULVERT BAT GATE

DESIGNED BY  
C.J.H.

SCALE  
NOT TO SCALE

SHEET  
8 OF 8

DATE REVISED  
2/8/2021 3:27:52 PM

STATE OF INDIANA  
DEPARTMENT OF NATURAL RESOURCES  
DIVISION OF RECLAMATION

DRAWN BY  
C.J.H.

PROJECT  
E009-230

SITE  
VARIOUS