

From: [Boyle, Douglas J \(DHS\)](#)
To: [Donna Tarr](#)
Cc: [IDHS Variances](#); [Fitzpatrick, Denise](#); margie.bovard@indy.gov; [Sprecher, Bryston](#)
Subject: RE: Local Variance - 6955 N Keystone Ave
Date: Monday, November 23, 2020 9:19:00 AM

Thanks, Donna. I've received the two additional documents. Again, this information will be provided to the Fire Prevention and Building Safety Commission for approval at its next meeting on **Tuesday, December 1, 2020**. Please let us know if you have any questions in the meantime.

Sincerely,



Douglas J. Boyle
Director – Fire Prevention and Building Safety Commission
Indiana Department of Homeland Security
Indiana Government Center South, Room E208
302 W. Washington Street, Indianapolis, IN 46204
Cell: (317) 650-7720
Email: doboyle@dhs.in.gov
Web: <http://www.in.gov/dhs>

From: Donna Tarr <dtarr@stenzcorp.com>
Sent: Monday, November 23, 2020 8:06 AM
To: Boyle, Douglas J (DHS) <DoBoyle@dhs.IN.gov>
Cc: IDHS Variances <Variances@dhs.IN.gov>; Fitzpatrick, Denise <dfitzpatrick@dhs.IN.gov>; margie.bovard@indy.gov; Sprecher, Bryston <BSprecher@dhs.IN.gov>
Subject: RE: Local Variance - 6955 N Keystone Ave

****** This is an EXTERNAL email. Exercise caution. DO NOT open attachments or click links from unknown senders or unexpected email. ******

Doug,
Attached are the documents submitted to Margie for the variance request.

From: Boyle, Douglas J (DHS) <DoBoyle@dhs.IN.gov>
Sent: Friday, November 20, 2020 3:37 PM
To: Donna Tarr <dtarr@stenzcorp.com>
Cc: IDHS Variances <Variances@dhs.IN.gov>; Fitzpatrick, Denise <dfitzpatrick@dhs.IN.gov>; margie.bovard@indy.gov; Sprecher, Bryston <BSprecher@dhs.IN.gov>
Subject: RE: Local Variance - 6955 N Keystone Ave

Ms. Tarr,

Denise forwarded your message to me, as I am responsible for handling all matters that must be presented to the Fire Prevention and Building Safety Commission for approval. On behalf of the Commission, we have received your request to have the Commission approve your locally-approved

variance pursuant to IC 22-13-2-7(b). Margie's message below will be provided to the Commission as part of its meeting materials for its next meeting on **Tuesday, December 1, 2020**. The meeting will be completely electronic through Webex, and access details to this meeting are now provided in the public notice on the Commission's main web page: <https://www.in.gov/dhs/2375.htm>.

If you provided Margie any additional information/documentation as part of this request, such as a request letter and plans identifying the location of the PIV(s), please provide me that information/documentation as well at your earliest convenience. Please let me and/or Bryston (copied here) know if you have any questions or concerns.

Thanks,

Doug Boyle



Douglas J. Boyle

Director – Fire Prevention and Building Safety Commission
Indiana Department of Homeland Security
Indiana Government Center South, Room E208
302 W. Washington Street, Indianapolis, IN 46204
Cell: (317) 650-7720
Email: doboyle@dhs.in.gov
Web: <http://www.in.gov/dhs>

From: Donna Tarr <dtarr@stenzcorp.com>
Sent: Friday, November 6, 2020 1:11 PM
To: IDHS Variances <Variances@dhs.IN.gov>
Subject: FW: Local Variance - 6955 N Keystone Ave

****** This is an EXTERNAL email. Exercise caution. DO NOT open attachments or click links from unknown senders or unexpected email. ******

Denise,
I'd like to add this variance approval to the next Commission meeting agenda, I did leave a message on your voice mail, and I hope this email finds it's way to you.
Please find the approval from Margie Bovard below.

From: Bovard, Margie F. <Margie.Bovard@indy.gov>
Sent: Thursday, November 5, 2020 8:47 AM
To: Donna Tarr <dtarr@stenzcorp.com>
Subject: Fw: Local Variance - 6955 N Keystone Ave

November 5, 2020

RE: Local Variance

Greenhouse and Building Expansion
6955 N Keystone Ave
Indianapolis, Indiana

Dear Ms. Tarr,

Thank you for your letter dated, November 4, 2020 requesting a local variance from Section 591-406, Chapter 591 of the Indianapolis-Marion County Fire Prevention Code which adopts NFPA 24, 1995 Edition, Section 3, requiring a post indicator valve for a fire service water supply line.

Your request and justifications for a variance from the provisions of Chapter 591-406 is in compliance with the provision of Section 591-246, Chapter 591 of the Indianapolis-Marion County Fire Prevention Code which was passed by the City-Council on April 29, 2002 and signed by Bart Peterson on May 2, 2002, and approved by the Fire Prevention and Building Safety Commission on May 8, 2002.

Based on the items listed in your letter dated November 4, 2020, a local variance to the above mentioned Section is granted by the Indianapolis Fire Department. In accordance with the exception to NFPA 24, Section 3-3.2, a post Indicator valve will not be located 40' away from the building due to site constraints. The Post Indicator Valve will be placed west of the building addition between the fence and sidewalk.

This approval must be presented to the Fire Prevention and Building Safety Commission as per IC 22-13-2-7. "The Commission shall review variances granted by a political subdivision to the fire safety laws and building laws adopted in its ordinances". This variance is not effective until it is approved by the Commission. There is no fee but the item must be placed on the Commission's agenda. Please contact Denise Fitzpatrick at the Indiana State Fire Prevention and Building Safety Office 317-232-6213 to place this item on the next Commission meeting agenda.

If you have any questions, feel free to contact me at 317-327-5529 or margie.bovard@indy.gov

Respectfully
Margie Bovard
Senior Fire Code Plans Examiner
Indianapolis Fire Department.



Stenz Construction Corporation
429 N Pennsylvania Street
Indianapolis, Indiana 46204
317.262.4999
www.StenzCorp.com

November 4, 2020

Margie Bovard (Margie.Bovard@indy.gov)
Indianapolis Fire Department
Fire and Life Safety Division
955 Fort Wayne Avenue
Indianapolis, Indiana 46202

RE: Local Variance - PIV
Sullivan Hardware & Garden
6955 N Keystone Avenue
Indianapolis, IN

Ms. Bovard,

Stenz Construction Corporation (General Contractor) is requesting a variance to the Marion County Code Section 591-406 that requires a post indicator valve on the private fire main for the proposed Sullivan Hardware new fire line work located at 6955 N. Keystone Avenue.

The requirement for a post indicator valve more than 40 feet away from the building creates difficulties for this project due to the property line close proximity to Keystone Avenue, the building is 18' to the property line creating difficulties for a location for the PIV.

An alternate post mount Post Indicator Valve will be placed in the landscape area within the property line next to Keystone Avenue (see JPS Engineering drawing attached). This location provides the necessary access, is located out of the way, and does not obstruct the fire lane.

For these reasons, we are requesting a Local Variance as proposed.

If you have any questions or require additional information, please feel free to contact me at your convenience.

Best Regards,
Donna Tarr-Project Manager

CONSTRUCTION DOCUMENTS

NUMBER	DATE	DESCRIPTION



FIRE PROTECTION SERVICE PLAN & DETAILS

SCALE: 1" = 10'

DATE: 02 SEPT 2020

PROJECT #: 20PSC19

DRAWN: NBV

COORD: NBV

APPROVED: NBV

FP001

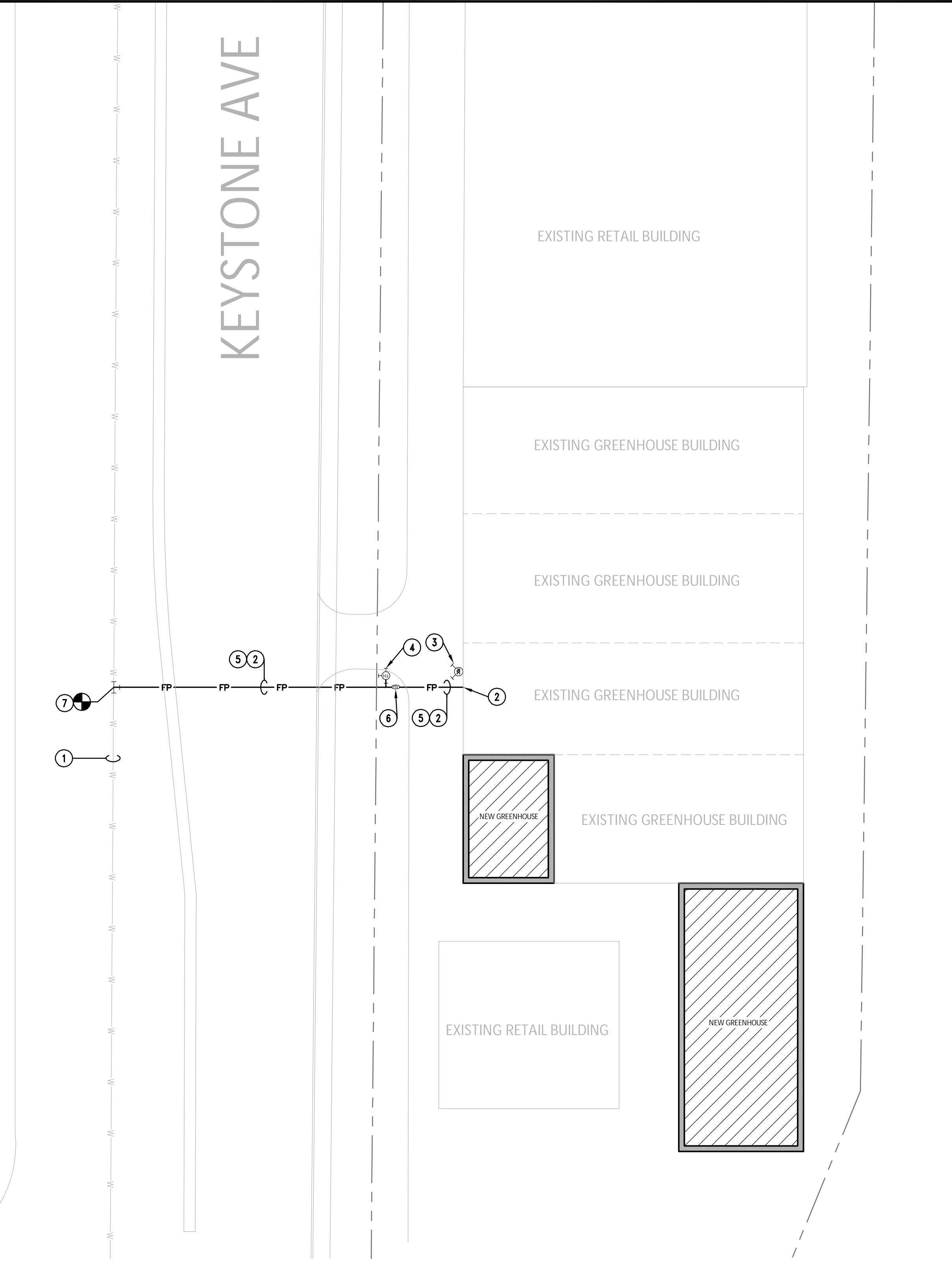

1 FIRE PROTECTION SERVICE PLAN
 SCALE: 1" = 20'

GENERAL NOTES

- THE CONTRACTOR SHALL BE RESPONSIBLE FOR OBTAINING, AND VERIFYING, THAT ALL PERMITS AND APPROVALS ARE OBTAINED FROM THE RESPECTIVE CITY, COUNTY, STATE AND FEDERAL AGENCIES PRIOR TO STARTING CONSTRUCTION.
- CONTRACTOR SHALL VERIFY LOCATION AND INVERT ELEVATIONS OF EXISTING SEWERS PRIOR TO START OF CONSTRUCTION.
- CONTRACTOR SHALL MAINTAIN A COMPLETE AND OPERABLE UTILITY SYSTEM AT ALL TIMES.
- CONTRACTOR SHALL INCLUDE COSTS FOR CUTTING AND PATCHING AS REQUIRED IN THEIR BID PROPOSAL TO COMPLETELY INSTALL THE WORK INDICATED.
- CONTRACTOR SHALL INCLUDE ALL TAP FEES, PERMIT FEES AND APPLICATION FEES IN THEIR BID PROPOSAL AS NECESSARY TO COMPLETELY INSTALL THE WORK INDICATED.
- INFORMATION SHOWN WAS OBTAINED FROM EXISTING AERIAL PHOTOGRAPHY OF EXISTING CONDITIONS AND IS UNCONFIRMED AND UNVERIFIED AND COULD BE INCOMPLETE. CONTRACTOR IS REQUIRED TO FIELD VERIFY THIS INFORMATION PRIOR TO INSTALLING FIRE PROTECTION LINE.
- CONTRACTOR SHALL COORDINATE EXACT UTILITY LOCATIONS WITH THE OWNER AND LOCAL UTILITY COMPANIES PRIOR TO COMMENCING ANY WORK. UTILIZE THE INDIANA UNDERGROUND UTILITY LOCATION SERVICE AT 811 OR 800-382-5544 PRIOR TO ANY EXCAVATION ON THE SITE.

GENERAL NOTES

- REFER TO UTILITY DETAILS FOR NOTE REFERENCES.
- CASTINGS TO BE NEENAH TYPE OR APPROVED EQUAL.
- CONTRACTOR TO VERIFY LOCATIONS AND ELEVATIONS OF EXISTING UTILITIES PRIOR TO THE START OF CONSTRUCTION.

PLAN NOTES

- CONTRACTOR TO FIELD VERIFY EXISTING WATER MAIN LOCATION AND SIZE. LOCATION SHOWN IS APPROXIMATE AND NOT EXACT.
- 6" FIRE PROTECTION SERVICE LINE (C900 PVC). BRING LINE UP INTO EXISTING GREENHOUSE SPACE FOR CONNECTION TO NEW FIRE PROTECTION SPRINKLER SYSTEM. COORDINATE EXACT LOCATION WITH ARCHITECTURAL AND SPRINKLER SHOP DRAWINGS.
- 2 1/2" SIAMESE FIRE DEPARTMENT CONNECTION MOUNTED ON BUILDING FACE.
- FIRE HYDRANT WITH VALVE AND NEW 6" SERVICE LINE.
- CONTRACTOR TO BORE NEW PIPE UNDER KEYSTONE AVE. CONTRACTOR TO FIELD VERIFY EXISTING UTILITIES THAT MIGHT EXIST IN RIGHT OF WAY AND IN THE PATH OF NEW FIRE PROTECTION SERVICE LINE.
- POST INDICATOR VALVE.
- 6" TAP ONTO EXISTING WATER MAIN. COORDINATE WORK WITH CITIZENS ENERGY GROUP.

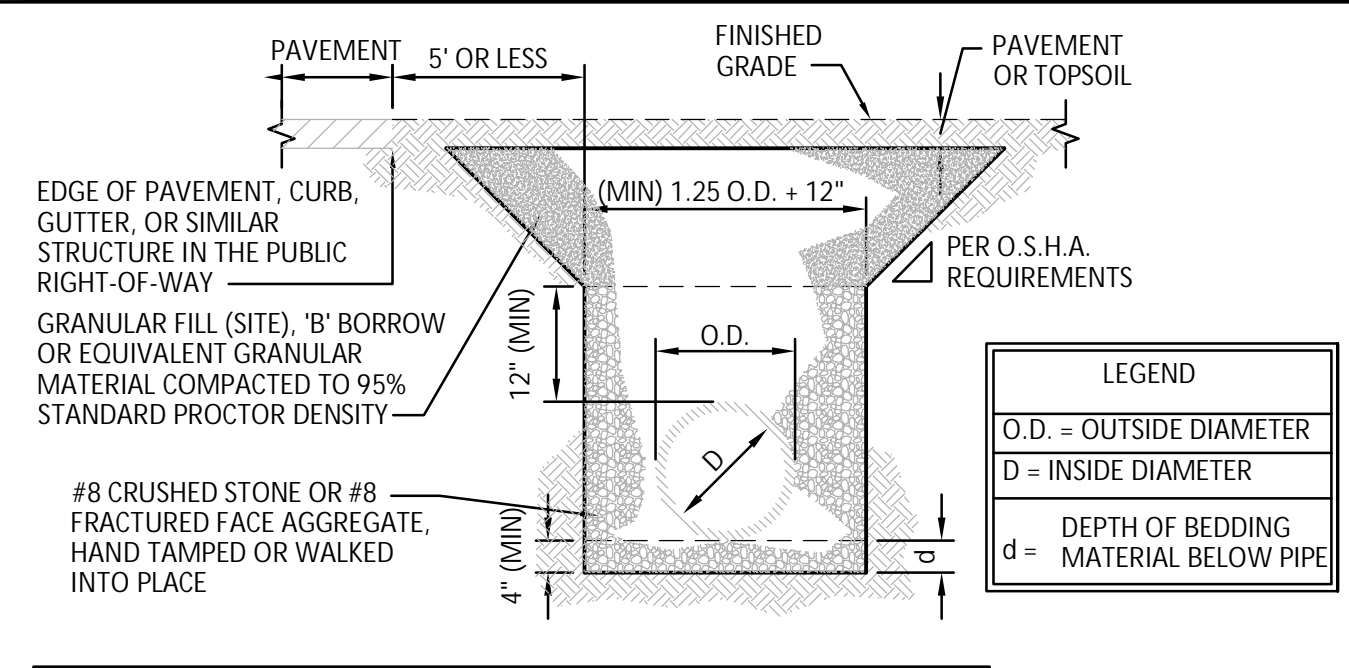

3 FLEXIBLE PIPE (PVC & HDPE) BEDDING DETAIL
 NO SCALE

NOTES:

- ALL BEDDING AND INITIAL BACKFILL SHALL BE INSTALLED 6" TO 12" BALANCED LIFTS.
- A MINIMUM OF 9" CLEARANCE SHALL BE PROVIDED ON EACH SIDE OF THE INSTALLED PIPE.
- BEDDING SHALL BE SHAPED TO RECEIVE THE PIPE BELL SO THAT THE PIPE BARREL IS UNIFORMLY SUPPORTED.
- REFER TO SPECIFICATIONS FOR ADDITIONAL INSTALLATION REQUIREMENTS.

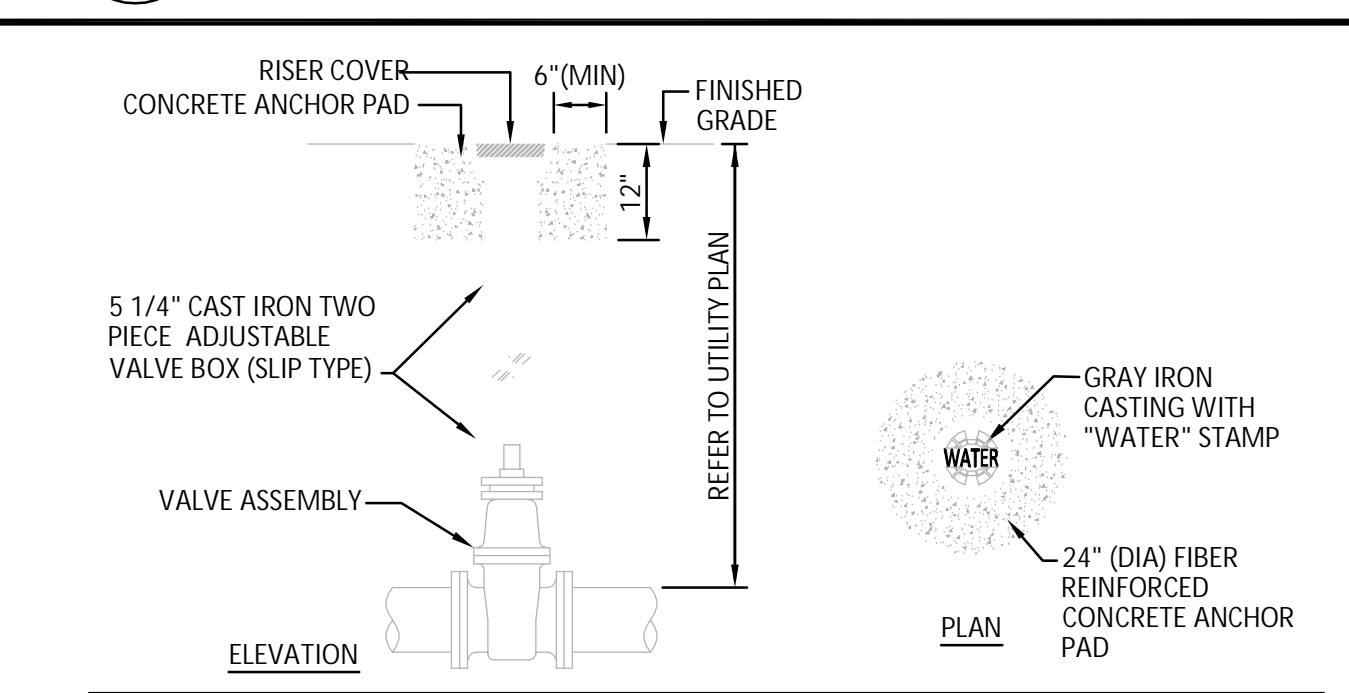

2 WATER VALVE BOX DETAIL
 NO SCALE

NOTES:

- VALVE BOX ASSEMBLY SHALL COMPLY WITH THE WATER UTILITY STANDARDS. WHERE NO STANDARDS ARE APPLICABLE, PROVIDE GRAY CAST IRON CLEANOUT LIKE EAST JORDAN 8555 SERIES OR APPROVED EQUAL (REFER TO SPECIFICATIONS). COVER SHALL BE FLUSH WITH FINAL GRADE.
- NO LOAD SHALL BE TRANSFERRED FROM THE VALVE BOX TO THE VALVE ASSEMBLY.
- CONCRETE ANCHOR PAD REQUIRED IN LAWN AND LANDSCAPE AREAS.
- WHEN VALVE ASSEMBLY IS DEEPER THAN 48", AN EXTENSION WILL BE REQUIRED TO BRING OPERATING NUT TO WITHIN 24" OF FINISHED GRADE.

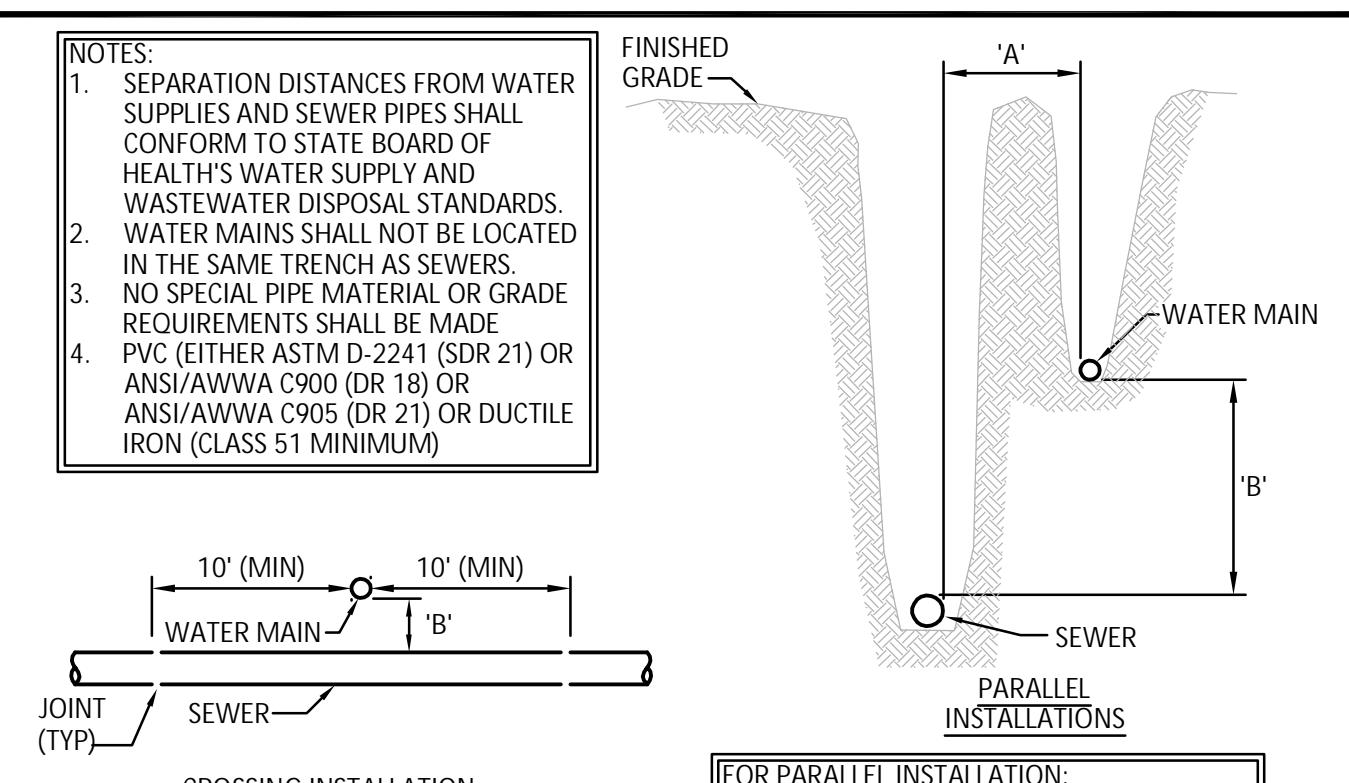

1 WATER AND SEWER CROSSING DETAIL
 NO SCALE

FOR PARALLEL INSTALLATION:
 IF 'A' IS GREATER THAN 10', REFER TO NOTE 3.
 IF 'A' IS LESS THAN 10' AND 'B' IS 18" OR LESS, REFER TO NOTE 4.
 IF 'A' IS LESS THAN 10' AND 'B' IS GREATER THAN 18", REFER TO NOTE 3.

FOR CROSSED INSTALLATION:
 IF 'B' IS GREATER THAN 18", REFER TO NOTE 3.
 IF 'B' IS 18" OR LESS, REFER TO NOTE 4.

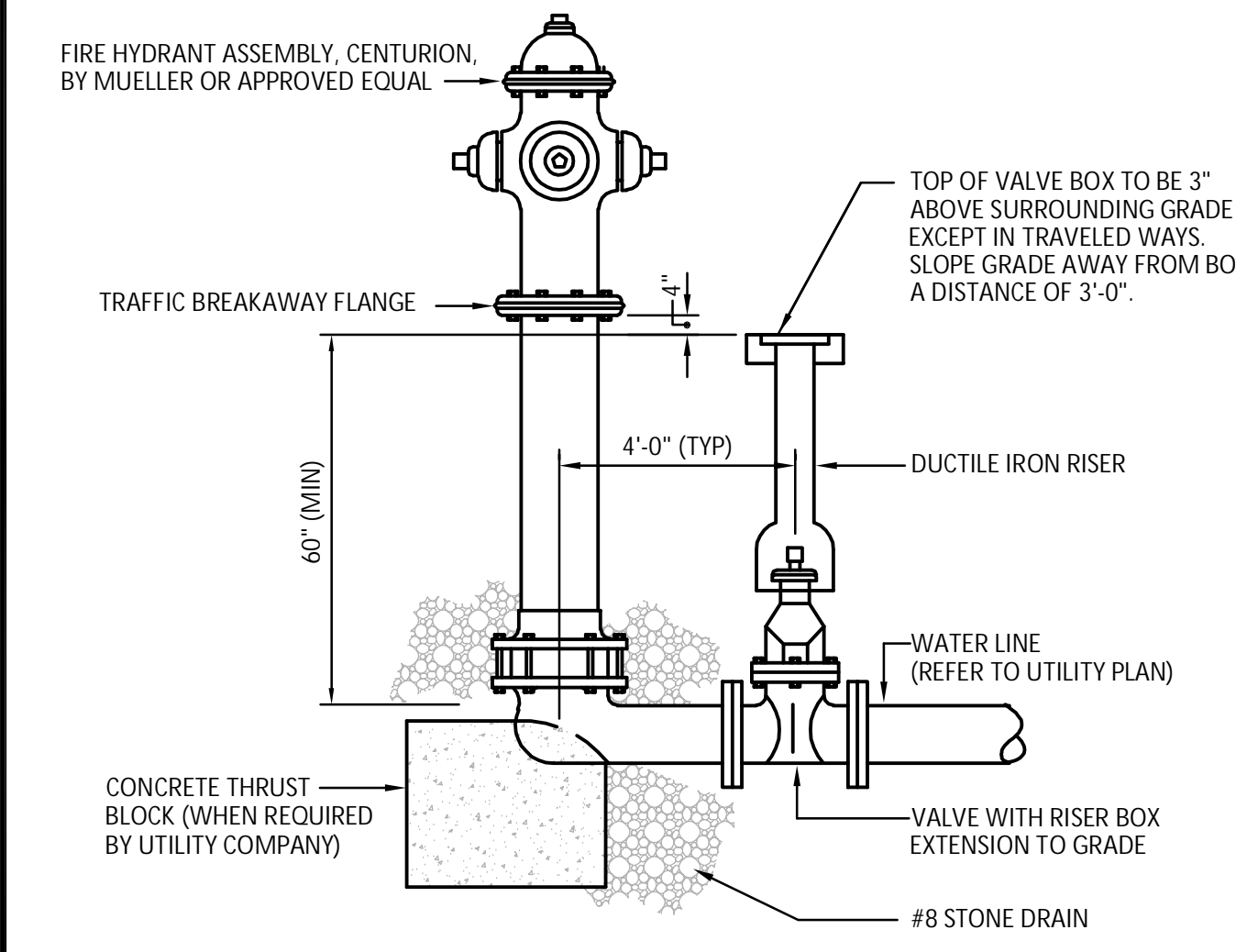

4 FIRE HYDRANT DETAIL
 NO SCALE

NOTES:

- HYDRANTS SHALL CONFORM TO SPECIFICATIONS OF THE GOVERNING AGENCY (WATER UTILITY AND/OR FIRE DEPARTMENT).
- CHECK WITH LOCAL WATER COMPANY AND/OR FIRE DEPT. FOR COLOR REQUIREMENTS.
- HYDRANTS MUST BE CHECKED BY A LOCAL FIRE DEPT. REPRESENTATIVE PRIOR TO INSTALLATION.
- INSTALLATION SHALL CONFORM TO NFPA 24.
- COORDINATE VALVE-TURN DIRECTION WITH THE LOCAL WATER COMPANY AND/OR FIRE DEPARTMENT.
- PROVIDE (4) 6" PAINTED PIPE BOLLARD FOR PROTECTION FROM VEHICULAR TRAFFIC. FIELD VERIFY EXACT LOCATION AND CONFIGURATIONS.
- PROVIDE FLOW RATE (GPM) FOR ALL NEW HYDRANTS AND FIRE DEPARTMENT CONNECTIONS.