

TABLE OF CONTENTS

Updated 08/21/2023

CHAPTER 1: GENERAL PROVISIONS

1.0	Title	1.1
1.1	Purpose and Intent	1.1
	1.1.1 Purpose.....	1.1
	1.1.2 Intent	1.1
1.2	Authority.....	1.2
1.3	Jurisdiction	1.2
1.4	Uniformity.....	1.2
1.5	Interpretation.....	1.2
	1.5.1 Minimum requirements	1.2
	1.5.2 Conflicting requirements	1.2
	1.5.3 Severability.....	1.3
	1.5.4 Saving Provision.....	1.3
	1.5.5 Exclusion.....	1.3
1.6	Amendments	1.3
1.7	Adoption	1.4
1.8	Effective Date	1.4
1.9	Repeal of Pre-Existing Zoning Ordinances	1.4

CHAPTER 2: DISTRICT BOUNDARIES AND USE CLASSIFICATIONS

2.0	Official Zoning Map	2.1
	2.0.1 Identification and location	2.1
	2.0.2 Final Authority	2.1
	2.0.3 Copies	2.1
	2.0.4 Amendment or replacement	2.1
2.1	Interpretation of District Boundaries.....	2.2
	2.1.1 Interpretation standards.....	2.2
	2.1.2 Executive Director Interpretation	2.2
	2.1.3 Plan Commission interpretation provision.....	2.2
	2.1.4 Effect of vacation on zoning district boundaries.....	2.3
2.2	General Standards and Regulations	2.3
	2.2.1 Uses.....	2.3
	2.2.2 Bulk use standards.....	2.3
	2.2.3 Parking standards	2.3
	2.2.4 Landscaping standards	2.3
	2.2.5 Sign standards	2.3

2.3	Establishment of Districts	2.3
2.4	District Classifications - General	2.4
2.4.1	Agricultural districts	2.4
2.4.2	Residential districts	2.4
2.4.3	Non-residential districts	2.5
2.4.4	Overlay districts.....	2.5
2.5	Standards and Regulations by District	2.5
2.5.1	A-1 General Agricultural District	2.5
2.5.2	A-2 Agricultural Industry District	2.6
2.5.3	RR Rural Residential District	2.8
2.5.4	L-1 Lake District	2.8
2.5.5	R-1 Single-family Residential District.....	2.8
2.5.6	R-2 Single and Two-family Residential District	2.9
2.5.7	R-3 Multi-family Residential District	2.9
2.5.8	R-4 Mobile & Manufactured Home Park Residential District	2.9
2.5.9	B-1 Neighborhood Business District	2.9
2.5.10	B-2 General Business District.....	2.9
2.5.11	B-3 Highway Business District.....	2.10
2.5.12	B-4 General Business Dense Development District.....	2.10
2.5.13	B-5 Transitional Business District.....	2.10
2.5.14	I-1 Light Industrial District	2.10
2.5.15	I-2 Heavy Industrial District.....	2.11
2.5.16	I-3 Industrial Park District.....	2.11
2.5.17	AED Amusement and Entertainment District	2.11
2.5.18	Overlay Districts	2.12

CHAPTER 3: SPECIFIC USE REQUIREMENTS AND PERFORMANCE STANDARDS

3.0	Lot Requirements	3.1
3.0.1	Lots	3.1
3.0.2	Number of principle buildings per lot.....	3.1
3.0.3	Division of lots	3.2
3.0.4	Corner lots.....	3.2
3.0.5	Street frontage and access.....	3.2
3.0.6	Lot area exclusions	3.2
3.0.7	Vision clearance triangle	3.2
	Figure 3.1 – Vision Clearance Triangle; Street & Road Intersections.....	3.3
	Figure 3.2 – Vision Clearance Triangle; Adjacent to a Railroad Crossing.....	3.4
	Figure 3.3 – Vision Clearance Triangle; Street or Road & Alley Intersection.....	3.5
	Figure 3.4 – Vision Clearance Triangle; Driveway.....	3.6
3.1	Home Occupations	3.6
3.1.1	Purpose and scope	3.6
3.1.2	Required conditions.....	3.7
3.1.3	Uses that are prohibited as home occupations	3.8
3.1.4	Examples of uses that frequently qualify as home occupations	3.8
3.1.5	Professional offices – special restrictions	3.9

3.1.6	Child care homes – special restrictions	3.9
3.2	Bed and Breakfast Establishments	3.11
3.2.1	Location	3.11
3.2.2	Health regulations	3.11
3.2.3	Ancillary commercial use prohibited	3.11
3.2.4	Classification of use	3.11
3.2.5	Number of rooms permitted.....	3.11
3.2.6	Length of stay.....	3.11
3.2.7	Operator requirement	3.11
3.2.8	Parking requirement	3.11
3.3	Manufactured and Mobile Homes	3.11
3.3.1	Type I Manufactured Homes	3.12
3.3.2	Type II Manufactured Homes	3.12
3.4	Temporary Manufactured or Mobile Homes	3.13
3.4.1	Temporary residence during home construction.....	3.13
3.4.2	Temporary residence for a care-giver/dependent relative.....	3.14
3.5	Mobile Home Parks and Subdivisions	3.14
3.5.1	Entrance and interior roads	3.14
3.5.2	Compliance verification	3.15
3.6	Campgrounds	3.15
3.6.1	Minimum size	3.15
3.6.2	Occupation of tents, cabins and recreational vehicles	3.15
3.6.3	Campground standards.....	3.15
3.7	Recreational Vehicle Park.....	3.16
3.7.1	Minimum size	3.16
3.7.2	Entrances and interior roads.....	3.16
3.7.3	Recreational vehicle park standards.....	3.17
3.7.4	All recreational vehicle parks shall meet the following standards.....	3.17
3.7.5	Site plan requirements.....	3.17
3.8	Satellite Dish Antenna.....	3.17
3.8.1	General purposes.....	3.17
3.8.2	General requirements.....	3.18
3.9	Amateur Radio Antenna.....	3.19
3.10	Wireless Communications Facilities (“Facilities”)	3.19
3.10.1	Purpose, authority and jurisdiction.....	3.19
3.10.2	New Wireless Support Structures and Wireless Facilities.....	3.21
3.10.2.1	Application and Approval Procedure.....	3.21
3.10.2.2	General approval standards	3.24
3.10.2.3	General performance standards.....	3.26
3.10.3	Existing Wireless Support Structures and/or Wireless Facility Modification	3.28

3.10.3.1	Application and Approval Procedure-Modifications, Site Improvement Upgrades, Facilities Alteration/Upgrade & Equipment Revisions.....	3.27
3.10.4	Application and Approval Procedure – Collocations.....	3.30
3.10.5	Construction, Placement or Use of Small Cell Facilities.....	3.31
3.11	Extractive Manufacturing.....	3.34
3.12	Digesters, Aerobic or Anaerobic.....	3.35
3.13	Hospital and Medical, Mental Health Facility (Or Psychiatric Hospital)	3.38
3.14	I-3 Zoning District.....	3.38
3.15	General Performance Standards	3.41
3.15.1	Authority	3.42
3.15.2	Compliance	3.42
3.15.3	Enforcement.....	3.42
3.15.4	Exceptions.....	3.42
3.15.5	General provisions	3.42
3.16	Special Exception use Criteria and Requirements	3.43
3.16.1	<u>Category 1</u> : Adult entertainment business; tattoo parlor	3.43
3.16.2	<u>Category 2</u> : Agricultural industry; agricultural research firm; asphalt plant (manufacturing); bottled gas storage & distribution yard; construction, heavy contractors; ethanol or other similar bio-processing plant; explosives, use or storage; hatchery, commercial; hazardous waste landfill/facility; incinerator; industrial waste facility; junkyard; landfill; recycling facility; scrap metal yard; sewage treatment plant, private; slaughter house.....	3.44
3.16.3	<u>Category 3-A</u> : Airport; correctional/penal facility/prison; railroad facilities ..	3.45
3.16.4	<u>Category 3-B</u> : Heliport.....	3.46
3.16.5	<u>Category 4</u> : Bed & breakfast establishment; boarding/rooming house	3.46
3.16.6	<u>Category 5</u> : Restaurant drive-thru; retail establishment (0-99,000 GSF)....	3.47
3.16.7	<u>Category 6</u> : Auction arena or sales barn (for livestock); driving range; golf course; neighborhood facility; recreational facility, indoor; recreational facility, outdoor, commercial; shooting range, indoor; shooting range, outdoor; stable or boarding, commercial; stadium, coliseum, athletic field - commercial; theater, outdoor	3.48
3.16.8	<u>Category 7</u> : Boat storage (commercial); bus garage; bus station, passenger; truck freight terminal; truck stop; truck wash; veterinary clinic	3.48
3.16.9	<u>Category 8</u> : Vacation home (aka: Vacation Rental, Holiday Home, Holiday Apartment, Tourist Home (VRBO))/Cabins	3.49
3.16.10	<u>Category 9</u> : Event Barns.....	3.50
3.17	CFO AND CAFO ADDITIONAL DEVELOPMENTAL AND USE STANDARDS	
	FOR ALL A-1 & I-2 DISTRICTS.....	3.51
3.17.1 – 3.17.2	Setbacks.....	3.51
3.17.3	IDEM.....	3.52
3.18	Odor Control Systems and Standards.....	3.52

3.18.1 Persons Responsible/Liable, Authority, Scope and Exclusions & Exemptions.....3.52

3.18.2 OCP Submission Requirements.....3.53

3.18.3 Fees.....3.53

3.18.4 Plan Compliance.....3.53

3.18.5 Violations.....3.53

3.18.6 Complaints.....3.54

3.18.7 Complaint Threshold.....3.54

3.18.8 Responsibility.....3.54

3.18.9 Standards.....3.54

3.18.10 Certification of Compliance.....3.54

3.18.11 Confirmation of Compliance Certificate.....3.55

3.18.12 Existing Sites.....3.55

3.19 Broadband Project Application Procedure 3.19-1 thru 3.19-83.56

CHAPTER 4: USE CLASSIFICATIONS AND PROVISIONS

4.0 Purpose and Intent4.1

4.1 Applicability4.1

4.2 Explanation of Use Classifications.....4.1

4.2.1 Official Schedule of Uses4.1

4.2.2 Permitted uses4.1

4.2.3 Special exception uses.....4.1

4.2.4 Accessory uses and structures.....4.2

4.2.5 Temporary uses and structures.....4.2

4.2.6 Nonconforming uses, structures, and uses and structures in combination..4.2

4.3 Accessory Use Provisions4.2

4.3.1 General provisions4.2

4.3.2 Domesticated animals4.2

4.3.3 Exotic animals.....4.2

4.3.4 Livestock animals & Bees.....4.2

4.3.5 Swimming pools4.4

4.3.6 Management offices4.4

4.3.7 Use, storage or parking of recreational vehicles4.4

4.4 Temporary Uses4.6

4.4.1 General provisions4.6

4.4.2 Standards.....4.7

4.5 Nonconforming uses and structures4.8

4.5.1 General provisions4.8

4.5.2 Single nonconforming lots of record4.9

4.5.3 Nonconforming lots of record in combination.....4.9

4.5.4 Nonconforming uses of land.....4.9

4.5.5	Nonconforming structures	4.10
4.5.6	Nonconforming uses of structures or structures and land in combination ..	4.10
4.5.7	Nonconforming districts	4.10
4.5.8	Nonconforming manufactured and mobile homes.....	4.11
4.5.9	Nonconforming decks – lake properties.....	4.13

CHAPTER 5: PLANNED UNIT DEVELOPMENT

5.0	Purpose and Intent	5.1
5.0.1	Purpose.....	5.1
5.0.2	Intent	5.1
5.1	Rezoning to a PUD	5.2
5.2	Requirements for a PUD	5.2
5.2.1	Ownership.....	5.2
5.2.2	Preliminary PUD Plan.....	5.2
5.2.3	Final PUD Plan.....	5.2
5.2.4	Compliance with this Ordinance	5.2
5.2.5	Permitted uses	5.3
5.3	PUD Submittal and Approval Process	5.3
5.3.1	Procedures for Preliminary PUD Plan.....	5.3
5.3.2	Amendments to an approved Preliminary PUD Plan	5.7
5.3.3	Procedures for Final PUD Plan.....	5.8
5.4	Final Plan Approval Not Acceptance of Dedication Offers	5.12
5.5	Financial Assurance Requirements	5.12
5.6	Recording the Final PUD Plan.....	5.12
5.7	Procedures for Platting a PUD	5.12
5.8	Failure to Initiate Construction after Final Development Plan Approval	5.12
5.8.1	Invalid projects	5.12
5.8.2	Extensions.....	5.13
5.8.3	Abandonment.....	5.13
5.9	As-Built Plans Requirement	5.13
5.10	Limitation of Rezoning.....	5.13
5.11	Proceedings for Enforcement	5.13
5.12	Fees.....	5.14
5.13	Penalties	5.14

CHAPTER 6: OVERLAY DISTRICTS

6.0	Purpose and Intent	6.1
6.1	Ordinance Repeal	6.1
6.2	Conservation and Flood Plain Overlay District	6.1
6.2.2	Regulations.....	6.1

6.2.3	District Boundaries.....	6.2
-------	--------------------------	-----

CHAPTER 7: RENEWABLE ENERGY SYSTEMS

WIND AND SOLAR SITING REGULATIONS

7.0	Purpose and Intent	7.1
7.0.1	Purpose.....	7.1
7.0.2	Intent	7.1
7.1	Applicability	7.1
7.2	Prohibition.....	7.1
7.3	Conflict with Other Regulations.....	7.1
7.4	District Regulations- WECS.....	7.2
7.4.1	Location	7.2
7.4.2	Height.....	7.2
7.5	Setback Requirements.....	7.3
7.5.1	Minimum setback distances for Commercial WECS Towers.....	7.3
7.5.2	Commercial WECS Power Collection and Transmission System	7.5
7.5.3	Minimum setback distances for Non-Commercial and Micro-WECS Towers.....	7.6
7.5.4	Horizontal extension for Non-commercial and Micro WECS	7.7
7.5.5	Minimum setback distances for all Meteorological Towers	7.7
7.5.6	Horizontal extension for all Meteorological Towers.....	7.7
7.6	Safety Design and Installation Standards.....	7.8
7.6.1	Equipment type	7.8
7.6.2	Industry standards and other regulations.....	7.8
7.6.3	Controls and brakes	7.8
7.6.4	Electrical components	7.8
7.6.5	Color and finish	7.9
7.6.6	Warnings.....	7.9
7.6.7	Climb prevention	7.10
7.6.8	Blade clearance.....	7.10
7.6.9	Lighting	7.10
7.6.10	Materials handling, storage and disposal.....	7.11
7.7	Other Applicable Standards	7.11
7.7.1	Guyed wire anchors	7.11
7.7.2	Sewer and water	7.11
7.7.3	Noise and vibration.....	7.11
7.7.4	Utility interconnection	7.11
7.7.5	Signage.....	7.11
7.7.6	Feeder lines	7.12
7.7.7	Other appurtenances.....	7.12
7.8	Operation and Maintenance	7.12
7.8.1	Physical modifications	7.12
7.8.2	Interference.....	7.12

7.8.3	Declaration of public nuisance	7.13
7.9	Decommissioning Plan	7.13
7.9.1	Content	7.13
7.9.2	Discontinuation and abandonment	7.14
7.9.3	Removal	7.14
7.9.4	Written notices.....	7.14
7.9.5	Costs incurred by the County	7.14
7.10	Liability Insurance	7.14
7.11	Application Procedures	7.15
7.11.1	Applications for all Wind Energy Conversion Systems Projects	7.15
7.11.2	Applications for non-commercial WECS	7.17
7.11.3	Applications for commercial WECS	7.17
7.11.4	Applications for all Meteorological Towers.....	7.19
7.11.5	Aggregated project applications	7.19
7.11.6	Fees	7.19
7.11.7	Permits.....	7.20
7.12	Pre-construction Requirements.....	7.20
7.12.1	FAA permit application	7.20
7.12.2	Decommissioning Plan	7.20
7.12.3	Econ Dev, Drainage, and Road Use & Maintenance Agreement	7.20
7.12.4	Erosion control plan.....	7.21
7.12.5	Utility plan.....	7.21
7.12.6	Avoidance and mitigation of damages to public infrastructure	7.21
7.13	Construction Requirements	7.21
7.13.1	Dust control.....	7.21
7.13.2	Drainage.....	7.21
7.14	Post-construction Requirements.....	7.22
7.14.1	Road repairs.....	7.22
7.14.2	As-Built Plans Requirement.....	7.22
7.14.3	Change in ownership.....	7.22
7.15	Commercial, Individual and Shared Solar Energy Systems	7.22
7.15.1	Purpose, Persons Liable, Authority, Scope and Exclusions & Exemptions.....	7.22
7.16	Application Requirements	7.24
7.17	District Regulations & Performance Standards	7.26
7.18	Commercial Solar Energy System’s Collection and Transmission System	7.31
7.19	Battery Storage Fields and Battery Storage Retrofits.....	7.31
7.19	District Regulations and Performance Standards for Battery Storage Fields (BSF).....	7.35

CHAPTER 8: PARKING AND LOADING STANDARDS

8.0	Purpose and Intent	8.1
8.1	General Standards.....	8.1

8.1.1	Minimum parking and loading requirements	8.1
8.1.2	Parking and loading for uses which have been intensified	8.1
8.1.3	Parking and loading for buildings which have been converted.....	8.1
8.1.4	Reduction in existing parking and loading facilities	8.1
8.2	Applicability	8.1
8.2.1	On-street parking.....	8.2
8.2.2	Location of accessory off-street parking and loading facilities.....	8.2
8.2.3	Off-street parking facilities-prohibition.....	8.2
8.2.4	Sharing of off-street parking facilities.....	8.2
8.2.5	Off-street loading and unloading spaces as they relate to required off-street parking	8.2
8.2.6	Exception for loading and unloading berths	8.2
8.3	Existing Parking & Loading Areas.....	8.3
8.3.1	Use of existing parking and loading areas	8.3
8.3.2	Parking and loading areas damaged or destroyed.....	8.3
8.3.3	Parking and loading areas servicing damaged or destroyed conforming or legally nonconforming buildings or structures.....	8.3
8.4	Shared Parking	8.3
8.4.1	Shared parking for uses with similar hours of operation.....	8.3
8.4.2	Shared parking for uses which operate at different hours of the day.....	8.3
8.4.3	Shared parking, temporary uses	8.4
8.5	Parking Spaces Accessible to the Disabled	8.4
8.5.1	Required spaces	8.4
8.5.2	General ADA design and layout requirements.....	8.5
8.5.3	Design deviation.....	8.5
8.5.4	ADA loading zones.....	8.6
8.5.5	Location	8.6
8.5.6	Signage and marking.....	8.6
	Table 8.1 Parking Spaces Accessible to the Disabled.....	8.7
8.6	Parking Development Standards	8.7
8.6.1	Dimensions	8.8
	Tale 8.2 Minimum Space & Aisle Dimensions of Parking Spaces.....	8.9
8.6.2	Layout and design	8.9
8.6.2.1	Driveways, parking spaces and back out aisles, additional standards.....	8.10
8.6.3	Surfacing and drainage	8.14
8.7	Parking and Storage of Certain Vehicles	8.15
8.7.1	Nuisance vehicles	8.15
8.7.2	Commercial vehicles	8.15
8.7.3	Temporary/portable storage units.....	8.15
8.8	Design Flexibility	8.16
8.8.1	Reduction of parking	8.16
8.8.2	Phasing of minimum parking requirements.....	8.16
8.8.3	Deviation from minimum parking requirements.....	8.16
8.9	Drive-Through and service point Stacking Space Requirements	8.17

8.9.1	Stacking lane dimensions and markings.....	8.17
8.9.2	Number of stacking spaces	8.17
	Table 8.3 Minimum Required Vehicle Stacking Spaces.....	8.17
8.10	Loading Space Requirements.....	8.18
	Table 8.4 Loading Space Requirements.....	8.18
8.10.1	Location	8.18
8.10.2	Size	8.19
8.10.3	Surface.....	8.20
8.10.4	Minimum setback distances for certain parking & loading spaces.....	8.20
	Table 8.5 – Minimum Setback Distances for Certain Parking/Loading Areas	8.21
8.11	Additional Requirements for Off-Street Parking & Loading Plans.....	8.21
8.11.1	Off-street parking and loading plan.....	8.21
8.11.2	Lease or easement.....	8.22
8.11.3	Setbacks	8.22
8.11.4	Minimum number of spaces required.....	8.22
8.11.5	Calculating the minimum number of spaces required	8.22
8.11.6	Administrative adjustment	8.23
8.12	Electric vehicle charging stations.....	8.23
8.12.1	General Requirements	8.24
	Table 8.6 - Required off-street parking spaces listing.....	8.26

CHAPTER 9: LANDSCAPING STANDARDS

9.0	Purpose and Intent	9.1
9.1	Applicability	9.1
9.2	Landscape Plan Requirement	9.1
9.2.1	Preparation.....	9.1
9.2.2	Content	9.2
9.3	General Landscaping Requirements.....	9.2
9.3.1	Agricultural Districts.....	9.2
9.3.2	Placement of trees	9.2
9.3.3	Vision clearance areas	9.3
9.3.4	Parking lot landscaping requirements.....	9.3
9.3.5	Protection of landscaped areas	9.3
9.3.6	Screening of outdoor activities.....	9.4
9.3.7	Screening requirements for wireless communications facilities.....	9.4
9.3.8	Screening of refuse and recycling areas.....	9.4
9.3.9	Screening requirements for service structures.....	9.5
9.3.10	Detention/retention basins and ponds	9.5
9.3.11	Preservation	9.5
9.4	Approved Landscaping Materials.....	9.5
9.4.1	Trees.....	9.5
9.4.2	Shrubs and vines.....	9.6

9.4.3 Ground cover 9.6

9.4.4 Screening materials..... 9.6

9.5 Installation and Maintenance9.7

9.5.1 Trees..... 9.7

9.5.2 Responsible party..... 9.7

9.5.3 Dead, dying or damaged plant materials 9.7

9.6 Fencing.....9.7

9.6.1 Construction materials..... 9.8

9.6.2 Height..... 9.8

9.6.3 Front yard limitations for residential uses..... 9.8

9.6.4 Decorative fences for residential uses 9.8

9.6.5 Non-residential fences..... 9.8

9.6.6 Municipal Regulations.....9.9

Table 9:1 Landscaping requirements.....9.10

CHAPTER 10: SIGN STANDARDS

10.0 Purpose and Intent 10.1

10.0.1 Purpose.....10.1

10.0.2 Intent10.1

10.1 Sign Permits..... 10.1

10.1.1 Sign permit requirement10.1

10.1.2 Information required for sign permit10.1

10.1.3 Permit fees10.2

10.1.4 Expiration of permit10.2

10.1.5 Effect of sign permit issuance.....10.2

10.1.6 Permit revocation10.2

10.2 General Requirements for All Signs..... 10.3

10.2.1 Display of permit.....10.3

10.2.2 Responsibility10.3

10.2.3 Maintenance.....10.3

10.2.4 Removal.....10.3

10.3 General Sign Regulations..... 10.3

10.3.1 Location10.3

10.3.2 Sign projection.....10.4

10.3.3 Movement or simulated motion.....10.4

10.3.4 Prohibitions10.4

10.3.5 Emissions10.5

10.3.6 Visual impairment10.5

10.3.7 Obstruction10.5

10.3.8 Prohibitions-State or Federal law or regulation.....10.5

10.3.9 Sign components10.5

10.4 Illumination..... 10.5

10.4.1 National standards10.5

10.4.2 Condition.....10.5

10.4.3 Reflection10.6

10.4.4 Shielding10.6

10.4.5 Electronic messaging (EM)10.6

10.5 Maintenance and Removal10.7

10.5.1 Inspection.....10.7

10.5.2 Removal of signs.....10.7

10.5.3 Maintenance.....10.8

10.5.4 Abandoned signs.....10.8

10.6 Determining the Measurements of a Sign.....10.8

10.6.1 Sign area.....10.8

10.6.2 Back-to-back signs10.8

10.6.3 Sign height10.8

Table 10:1 Determining the Measurement of a Sign.....10.9

10.7 Sign Standards for Residential Zoning Districts.....10.9

10.7.1 Applicable districts.....10.9

10.7.2 L-1, R-1, R-2 & R-4 Residential Districts Used For Single Family Dwelling or Two Family Dwelling Purposes.....10.9

10.7.3 R-3 & R-4 Residential Districts Used For Multi-Family Dwelling Units or Manufactured Home Park Purposes.....10.10

10.7.4 All residential districts used for institutional purposes10.11

Table 10.1 Permanent identification sign regulations for all residential districts.....10.11

10.8 Standards for Commercial and Industrial Zoning Districts.....10.11

10.8.1 Applicable Districts10.11

Table 10.2 Sign Regulations for Commercial and Industrial Districts.....10.12

10.8.2 I-310.14

10.8.3 Shared advertising signs10.14

10.8.4 Roof signs.....10.15

Figure 10.2 Shared Advertising Sign.....10.15

10.9 Off Premise Signs.....10.16

10.9.1 State permitting compliance10.16

10.9.2 Billboards, location10.16

10.9.3 Billboards, spacing and size, lighting10.16

10.9.4 Billboards, digital10.17

10.9.5 Yard signs (off-premise only).....10.17

10.9.6 Disposable signs (off-premise only).....10.18

10.9.7 Signs on farm property10.19

10.9.8 Other off-premise signs.....10.19

10.10 Legal Nonconforming Signs.....10.19

10.10.1 Exception10.19

10.10.2 Maintenance and repair.....10.19

10.10.3	Improvements	10.19
10.10.4	Destroyed or damaged	10.20
10.11	Prohibited Signs	10.20
10.11.1	Search lights	10.20
10.11.2	Tower & WECS signs	10.20
10.11.3	Signs similar to emergency or traffic functions	10.20
10.11.4	Signs which obstruct	10.20
10.11.5	Other signs	10.20
10.12	Exempt Signs	10.20
10.12.1	Cylindrical Poles	10.21
10.12.2	Agricultural signs	10.22
10.12.3	Drive-through boards	10.22
10.12.4	Feather flag banners	10.22
10.12.5	Flags	10.22
10.12.6	Historical location signs	10.22
10.12.7	Government signs	10.22
10.12.8	Integral signs	10.23
10.12.9	Incidental parking lot signs	10.23
10.12.10	Incidental signage, other	10.24
10.12.11	Yard signs – on premise	10.24
10.12.12	Disposable signs – on premise	10.24
10.12.13	Suspended signs	10.24
10.12.14	Window signs and signs viewable through a window	10.25
10.12.15	A-frame and T-frame signs	10.25
10.12.16	Decorative signs (banners, lights, balloons, pennants and streamers)	10.25
10.12.17	Community service central displays/Community adoption signs	10.25
10.12.18	Bench signs	10.26
10.12.19	Changeable copy signs, portable	10.26
10.12.20	Neighborhood watch and similar community awareness signs	10.26
10.12.21	Barn Quilt Signs	10.27
10.12.22	Water tower signs	10.27
10.12.23	Retail signage	10.27
10.12.24	Natural composite signs	10.27
10.12.25	Vehicle signs	10.28
10.12.26	Murals, wall graphics and works of art	10.28
10.12.27	Public signs	10.28
10.12.28	Utility marker signs	10.28
10.12.29	Park or athletic field fence signage, wall signage and scoreboard signage, subject to the standards listed below	10.28
10.13	Temporary Signs	10.28

CHAPTER 11: ADMINISTRATIVE BODIES AND OFFICIALS

11.0	Summary of Authority	11.1
11.1	Bodies and Officials	11.1
11.1.1	County Commissioners	11.1
11.1.2	Municipal legislative bodies	11.1

11.1.3	Area Plan Commission	11.2
11.1.4	Board of Zoning Appeals	11.4
11.1.5	Technical Review Committee	11.6
11.1.6	Hearing Examiner.....	11.8
11.1.7	Hearing Officer.....	11.8
11.1.8	Plat Committee.....	11.8

CHAPTER 12: ADMINISTRATION

12.0	Application and Permit Types	12.1
12.0.1	Petition applications required.....	12.1
12.0.2	Applications, general	12.1
12.1	Official Fee Schedule	12.2
12.1.1	Maintenance.....	12.2
12.1.2	Availability	12.3
12.1.3	Responsibility of payment.....	12.3
12.1.4	Payment in full.....	12.3
12.1.5	Contracting of independent professionals.....	12.3
12.2	Public Hearings and Meetings	12.3
12.2.1	Setting a hearing or meeting.....	12.3
12.2.2	Review of application materials	12.4
12.2.3	Conduct of hearings	12.4
12.2.4	Examination and copying of application and other documents.....	12.4
12.3	Successive Applications (Petitions), Appeals.....	12.5
12.3.1	Second applications barred without new grounds.....	12.5
12.3.2	New grounds to be stated.....	12.5
12.3.3	Summary denial with or without hearing	12.5
12.3.4	Exception	12.5
12.4	Development Standards Variance	12.5
12.4.1	Authority	12.6
12.4.2	Burden of proof.....	12.6
12.4.3	Application.....	12.6
12.4.4	Notification	12.6
12.4.5	Action by Executive Director.....	12.6
12.4.6	Public hearing	12.7
12.4.7	Decision criteria prescribed by state law.....	12.7
12.4.8	Additional decision criteria.....	12.7
12.4.9	Written Findings of Fact.....	12.8
12.4.10	Conditions and/or commitments	12.8
12.4.11	Limitation.....	12.9
12.4.12	Termination	12.10
12.4.13	Revocation of a variance	12.10
12.4.14	Appeals	12.11
12.5	Special Exception Use Permit.....	12.11
12.5.1	Authority	12.11
12.5.2	No presumption of approval	12.11

12.5.3	Application.....	12.12
12.5.4	Notification	12.12
12.5.5	Action by the Executive Director.....	12.12
12.5.6	Public hearing	12.12
12.5.7	Decision criteria.....	12.12
12.5.8	Additional decision criteria.....	12.13
12.5.9	Possible action by the Area Board of Zoning Appeals	12.13
12.5.10	Written Findings of Fact.....	12.14
12.5.11	Conditions and/or commitments	12.14
12.5.12	Limitation.....	12.15
12.5.13	Termination	12.16
12.5.14	Appeals	12.16
12.6	Appeal of an Administrative Decision.....	12.17
12.6.1	Purpose.....	12.17
12.6.2	Authority	12.17
12.6.3	Parties entitled to appeal.....	12.18
12.6.4	Application.....	12.18
12.6.5	Action by the Executive Director.....	12.18
12.6.6	Notification	12.18
12.6.7	Possible action by the Board of Zoning Appeals.....	12.18
12.6.8	Review by judicial review.....	12.19
12.6.9	Right to grant variance in deciding appeals	12.19
12.6.10	Conditions and limitations on rights granted by appeal	12.19
12.7	Zoning Ordinance Amendment.....	12.19
12.7.1	Purpose.....	12.19
12.7.2	Authority	12.20
12.7.3	Parties entitled to initiate amendments	12.20
12.7.4	Approval.....	12.20
12.8	Zoning Map Amendment (Rezoning).....	12.21
12.8.1	Purpose.....	12.21
12.8.2	Authority	12.22
12.8.3	Parties entitled to initiate amendments	12.22
12.8.4	Application.....	12.23
12.8.5	Notification	12.23
12.8.6	Public hearing	12.23
12.8.7	Decision criteria.....	12.23
12.8.8	Possible action by the Area Plan Commission.....	12.24
12.8.9	Certification by the Area Plan Commission.....	12.25
12.8.10	Possible action by the appropriate legislative body.....	12.25
12.8.11	Effective date	12.25
12.8.12	Written commitments.....	12.25
12.9	Zoning Ordinance Interpretation.....	12.26
12.9.1	Authority	12.27
12.9.2	Parties entitled to seek interpretations	12.27
12.9.3	Application requests	12.27
12.9.4	Decision criteria.....	12.27

12.9.5	Possible action by the Executive Director	12.27
12.9.6	Recording.....	12.28
12.9.7	Limitations on use interpretations	12.28
12.9.8	Appeals	12.28
12.10	Planned Unit Development	12.28
12.11	Improvement Location Permit.....	12.28
12.11.1	Improvement Location Permit required.....	12.28
12.11.2	Improvement Location Permit not required	12.29
12.11.3	Application.....	12.30
12.11.4	Action by the Executive Director (and/or his or her designee).....	12.30
12.11.5	Expiration of an Improvement Location Permit	12.31
12.11.6	Failure to obtain an Improvement Location Permit.....	12.31
12.11.7	Limitations.....	12.31
12.11.8	Recording.....	12.31
12.12	Certificate of Occupancy Permit	12.32
12.12.1	Issuance and recording	12.32
12.12.2	Failure to obtain a Certificate of Occupancy Permit	12.32
12.13	Site Development Plan Review	12.32
12.13.1	Purpose.....	12.32
12.13.2	Applicability and authority	12.33
12.13.3	Initiation.....	12.33
12.13.4	Submission.....	12.33
12.13.5	Content Requirements.....	12.33
12.13.6	Administrative procedures	12.36
12.13.7	Notice.....	12.37
12.13.8	Action on site development plans	12.37
12.13.9	Standards for site development plan review	12.37
12.13.10	Conditions on plans.....	12.39
12.13.11	Public improvement performance guarantees	12.39
12.14	Written Commitments	12.39
12.14.1	Purpose, intent and authority.....	12.39
12.14.2	Commitments for rezoning or PUD proposal	12.40
12.14.3	Standard forms.....	12.40
12.14.4	Binding effect	12.40
12.14.5	Effective date of commitment	12.41
12.14.6	Covenant running with the land	12.41
12.14.7	Enforcement.....	12.41
12.14.8	Recording.....	12.41
12.14.9	Modification and termination.....	12.42
12.14.10	Public notice.....	12.42
12.14.11	Validity of other land use restrictions	12.42
12.15	Zoning Hearing Officer and Alternate Procedure.....	12.42
12.15.1	Authorization of the Area Plan Hearing Officer	12.42
12.15.2	Recommendation of the Area Plan Hearing Officer and Alternate	12.42
12.15.3	Approval of the Area Plan Hearing Officer and Alternate Recommendations	12.43

12.15.4	Powers and Duties of Zoning Hearing Officer.....	12.43
12.15.5	Alternate Procedure	12.43
12.16	Addressing, Road/Street/Alley Naming & Bridge Dedications	12.43
12.16.1	Purpose and intent	12.43
12.16.2	Applicability	12.43
12.16.3	Definitions	12.43
12.16.4	Ordinance Repeal	12.44
12.16.5	Bridge Dedications	12.44
12.16.6	Addressing	12.44
12.16.7	Street/Road/Alley Name Assignments or Changes.....	12.46

CHAPTER 13: ENFORCEMENT

13.0	General Provisions	13.1
13.0.1	Authority	13.1
13.0.2	County.....	13.1
13.0.3	Area Plan Commission	13.1
13.0.4	Persons Liable.....	13.1
13.0.5	Right of Entry	13.1
13.0.6	Stop Work Order	13.1
13.1	Civil Zoning Violations.....	13.2
13.1.1	Enforcement Procedures.....	13.2
13.1.2	Enforcement Without Prior Notice	13.2
13.1.3	Warning Ticket	13.2
13.1.4	Citations	13.3
13.1.5	Appeals	13.5
13.1.6	Trial	13.6

CHAPTER 14: DEFINITIONS

14.0	Purpose and Intent	14.1
14.1	Rules	14.1
14.1.1	Word tense.....	14.1
14.1.2	Persons and other responsible parties	14.1
14.1.3	Masculine vs. feminine	14.1
14.1.4	Distinguishing between what is mandatory, permissive & preferred.....	14.2
14.1.5	Using and occupying a space.....	14.2
14.1.6	Lot, plot or parcel.....	14.2
14.1.7	Time	14.2
14.1.8	Captions, illustrations and tables	14.2
14.2	Words and Phrases Defined.....	14.2

APPENDICES

Appendix A: Official Schedule of Uses	A.1
Appendix B: Bulk Use Standards	B.1

Appendix C: Recommended Plant Materials C.1
Appendix D: Process Charts D.1

.....



CHAPTER 1 GENERAL PROVISIONS

1.0 TITLE

These regulations shall hereafter be known and cited as the White County, Indiana Zoning Ordinance.

1.1 PURPOSE AND INTENT

1.1.1 Purpose

The purpose of this Ordinance is to regulate and control the use and development of land within the jurisdictions of the White County Area Plan Commission.

1.1.2 Intent

The intent of this Ordinance is to promote the public health, safety and general welfare and more specifically to:

- A. Support the goals, objectives and policies of the White County Comprehensive Plan and other plans adopted by the County and participating municipalities;
- B. Provide for efficient development of natural resources, agriculture, business and industry;
- C. Provide for the conservation of property values and natural resources;
- D. Provide for the growth of the county, city, and towns commensurate with the efficient and economical use of public funds in such areas that are under the jurisdiction of the White County Area Plan Commission;
- E. Identify the boundaries of zoning districts, by reference to the official zoning map;
- F. Prohibit uses, buildings or structures which are incompatible with the stated purpose of the district in which it is located or proposed;
- G. Create and establish standards to which the uses, buildings or structures within each district shall conform therein restricting and regulating their location, construction, reconstruction or alteration;
- H. Regulate the intensity of each lot by requiring open space areas around buildings and structures and further providing adequate safety, light, and ventilation;
- I. Limit congestion on public roadways;
- J. Preserve and enhance features of environmental or historic significance;
- K. Designate and define the powers and duties of the bodies and/or officials administering and enforcing this Ordinance and the White County, Indiana Subdivision Control Ordinance and the procedures by which this Ordinance is administered; and
- L. Prescribe penalties for the violation of this Ordinance.

1.2 AUTHORITY

This Ordinance is adopted by White County pursuant to its authority under the laws of the State of Indiana, IC 36-7-4 et seq. Whenever codes cited in this Ordinance refer to Indiana Code (IC) where the state statute has been amended or superseded, this Ordinance shall be deemed amended in reference to the new or revised Indiana Code.

1.3 JURISDICTION

The provisions, standards and regulations of this Ordinance shall apply to all land within White County, except for those areas under the jurisdiction of a city or town that is not a member of the White County Area Plan Commission pursuant to IC 36-7-4-201(b).

1.4 UNIFORMITY

Those portions of the text which include the name or names of one or several of the adopting jurisdictions (in capital letters and within parentheses) are effective in those specific jurisdictions only. All other portions of the text are effective in all jurisdictions.

1.5 INTERPRETATION

1.5.1 Minimum requirements

In their interpretation and application, the provisions of these regulations shall be held to be the minimum requirements for the promotion of the public health, safety, and general welfare of the people at large, and are designed to encourage the establishment and maintenance of reasonable community standards for the physical environment.

1.5.2 Conflicting requirements

A. Zoning Ordinance provisions

If two or more provisions within this Ordinance conflict, or are otherwise inconsistent with one another, then the provision which is most restrictive, or imposes higher standards, shall govern.

B. Public provisions

These regulations are not intended to interfere with, abrogate, or annul any other ordinance, rule or regulation, statute, or other provision of law. Where any provision of these regulations imposes restrictions different from those imposed by any other provision of these regulations or any other ordinance, rule or regulation, or other provision of law, those provisions which are more restrictive or impose higher standards shall govern.

C. Private provisions

These regulations are not intended to abrogate any easement, covenant or any other private agreement or restriction, provided that where the provisions of these regulations are more restrictive or impose higher standards or regulations than any easement, covenant, or other private agreement or restriction, the requirements of these regulations shall govern. Where the provisions of the easement, covenant, or private agreement or restriction impose duties and obligations more restrictive, or

higher standards than the requirements of these regulations or the determinations of the Commission in enforcing these regulations, and the private provisions are not inconsistent with these regulations or determinations hereunder, then the private provisions shall be operative and supplemental to these regulations, or the determinations made there under. Private provisions shall only be enforced privately.

1.5.3 Severability

If any part or provision of these regulations or application thereof to any person or circumstances is judged invalid by any court of competent jurisdiction, the judgment having been rendered shall not affect or impair the validity of the remainder of these regulations or the application thereof to other persons or circumstances. The legislative body hereby declares that it would have enacted the remainder of these regulations even without any part, provision or application.

1.5.4 Saving provision

Except as expressly provided for herein, this ordinance shall not be construed as either:

- A. Abating any action now pending under or by virtue of any preexisting ordinance; or
- B. Discontinuing, abating, modifying, or altering any penalty accruing or about to accrue; or
- C. Affecting the liability of any person, firm, or corporation; or
- D. Waiving any right of a participating jurisdiction under any section or provision existing at the time of the effective date of this ordinance; or
- E. Vacating or annulling any rights obtained by any person, firm, or corporation, by lawful action of the participating jurisdictions or administrative bodies thereof.

1.5.5 Exclusion

Nothing in this Ordinance or in any rules, regulations or orders issued pursuant to this Ordinance shall be deemed to restrict or regulate or to authorize any unit of government, legislative body, Plan Commission or Board of Zoning Appeals now or hereafter established, to restrict or regulate the exercise of the power of eminent domain by the state or by any state agency, or the use of property owned or occupied by the state or any state agency.

1.6 AMENDMENTS

For the purpose of providing for the public health, safety, and general welfare, the White County Commissioners or appropriate legislative body, on recommendation of the Area Plan Commission, may from time to time amend the text of this Ordinance and/or the Official Zoning Map incorporated by reference in this Ordinance. Public hearings on all proposed amendments shall be held in the manner prescribed by state law.

1.7 ADOPTION

The following is a record of the adoption procedure of this Ordinance, conducted by the White County Area Plan Commission, the City of Monticello, and the Towns of Brookston, Burnettsville, Chalmers, Monon, Reynolds, and Wolcott.

- A. Public hearings;
- B. Recommendation and certification by the Area Plan Commission;
- C. Adoption by governmental units:
 - 1. County of White;
 - 2. City of Monticello;
 - 3. Town of Brookston;
 - 4. Town of Burnettsville;
 - 5. Town of Chalmers;
 - 6. Town of Monon;
 - 7. Town of Reynolds; and
 - 8. Town of Wolcott.
- D. Recorded with the White County Recorder

1.8 EFFECTIVE DATE

This ordinance shall become effective on the date in which it is adopted by a given jurisdiction.

1.9 REPEAL OF PRE-EXISTING ZONING ORDINANCES

The Zoning Ordinances Number 97-12-5958 of White County, Number 12-28-94 of Brookston, Number 94-2 of Chalmers, Number 12-28-94 of Reynolds, Number 12-28-94 of Monticello, Dated December 6, 1994 of Burnettsville, Dated December 6, 1994 of Monon, and Dated December 6, 1994 of Wolcott is repealed by this Ordinance. Said repeal shall become effective on the effective date of this Ordinance.

CHAPTER 2 DISTRICT BOUNDARIES AND STANDARDS

2.0 OFFICIAL ZONING MAP

White County is divided into zoning districts as described and defined in this Ordinance and as shown on the Official Zoning Map. The Official Zoning Map, together with all explanatory matter thereon, is hereby adopted by reference and declared to be a part of this Ordinance.

2.0.1 Identification and Location

The Official Zoning Map shall be maintained electronically by the Staff and identified as GIS Zoning Map and be located on the White County Indiana official web site. The Official Zoning Map shall also include the ordinance number by which it was adopted and the date of adoption. The official zoning map shall be available for public inspection during county business hours in the office of the White County Area Plan Commission.

2.0.2 Final Authority

The Official Zoning Map shall be the final authority as to the current zoning status of land and water areas, buildings, and other structures within the jurisdiction of the White County Area Plan Commission.

2.0.3 Copies

Copies of the Official Zoning Map may be made and distributed to interested persons. All copies of the Official Zoning Map shall be labeled as copies and include the date on which it was obtained. The party requesting the copy shall bear the cost of each copy as listed in the Official Fee Schedule.

2.0.4 Amendment or replacement

No changes of any nature shall be made on the Official Zoning Map except in conformance with the procedures set forth in Chapter 12, Administration. Any unauthorized change by any person or persons shall be considered a violation of this Ordinance.

A. Amendment (Rezoning)

Upon the passage of a map amendment (rezoning), the County Commissioners or appropriate legislative body shall certify a copy of the amendment to the Executive Director. The Executive Director shall cause the change to be made to the Official Zoning Map in accordance with the amendment. The Executive Director shall cause the Official Zoning Map to show a notation electronically identifying the ordinance number, file number, and date of adoption by the appropriate legislative body.

B. Preservation of the prior Official Zoning Map

Unless the prior Official Zoning Map has been lost or has been totally destroyed, the prior map or any significant parts thereof shall be preserved, together with all available records pertaining to its adoption or amendment.

2.1 INTERPRETATION OF DISTRICT BOUNDARIES

2.1.1 Interpretation Standards

Zoning district boundaries illustrated on the Official Zoning Map shall be interpreted as follows:

A. Streets and easements

Boundaries shown within the lines of roads, easements, and transportation rights-of-way shall be deemed to follow the centerlines.

B. Property lines

Boundaries indicated as following section or fractional sectional lines, platted lot lines, or municipal corporation limits shall be construed to follow such lines.

C. Bodies of water

Boundaries indicated as approximately following the center line of streams, rivers, or other bodies of water shall be construed to follow such center lines. Boundaries indicated as following shore lines shall be construed as moving with any change in the actual shore line.

D. Divided lots

In the event that a boundary line divides a lot or parcel, the Executive Director shall determine the applicable zoning district. The Executive Director may require a rezone or replat of the site if any portion of a construction or development proposal overlaps two or more zoning districts. The petitioner shall be responsible for filing the appropriate forms and for applying the appropriate filing fees to rezone or replat the lot or parcel. If a portion of a lot or parcel is in an overlay district, the entire lot or parcel shall be deemed as being within the overlay district.

E. Extensions of lines

Boundaries indicated as parallel to or extensions of the features listed above in Section 2.101(A) through (D) shall be construed as such.

F. The Conservation and Flood Plain Overlay District boundaries

Boundaries of the Conservation and Flood Plain Overlay District shall coincide with the boundaries as documented on the Flood Insurance Rate Maps for White County.

2.1.2 Executive Director Interpretation

The Executive Director shall determine the applicable zoning for each property in the Area Plan Commission's jurisdiction. Any ruling of the Executive Director may be appealed to the Board of Zoning Appeals.

2.1.3 Plan Commission interpretation provision

If the Executive Director cannot definitively determine the location of a district boundary, immediate action on any affected application shall be delayed until such time when the Plan Commission determines the zoning district boundary. The Plan Commission shall interpret the location of the district boundary with reference to the scale of the Official

Zoning Map and the purposes set forth in all relevant provisions of this Ordinance. This interpretation may occur as part of a regular or special Plan Commission meeting and shall not require a public hearing. Decisions of the Plan Commission may not be appealed to the Board of Zoning Appeals, but may be appealed to a court of jurisdiction.

2.1.4 **Effect of vacation on zoning district boundaries**

Whenever any street, alley, public way, railroad right-of-way, or other similar area is vacated by the proper authority, the adjoining zoning districts shall be extended automatically to the center of the vacated area. All areas included in the vacation shall then be subject to all applicable regulations of the extended zoning district. In the event of a partial vacation, the adjoining zoning district, or the zoning district nearest the portion vacated, shall be extended automatically to include all of the vacated area.

2.2 **GENERAL STANDARDS AND REGULATIONS**

General standards and regulations for each district are prescribed as follows:

2.2.1 **Uses**

Permitted, accessory, temporary, special exception, and prohibited uses shall be as prescribed by Chapter 3, Specific Use Requirements and Performance Standards and Appendix A, Official Schedule of Uses.

2.2.2 **Bulk use standards**

As prescribed by the Bulk Use Standards Matrix located in Appendix B of this Ordinance

2.2.3 **Parking standards**

As prescribed by Chapter 8, Parking and Loading Standards.

2.2.4 **Landscaping standards**

As prescribed by Chapter 9, Landscaping Standards.

2.2.5 **Sign standards**

As prescribed by Chapter 10, Sign Standards.

2.3 **ESTABLISHMENT OF DISTRICTS**

All land within the jurisdiction of this ordinance is divided into the following types of districts:

- A. General Agriculture District (A-1)
- B. Agricultural Industry District (A-2)
- C. Rural Residential District (RR)
- D. Lake District (L-1)
- E. Single-family Residential District (R-1)

- F. Single and Two-family Residential District (R-2)
- G. Multi-family Residential District (R-3)
- H. Mobile Home Park Residential District (R-4)
- I. Neighborhood Business District (B-1)
- J. General Business District (B-2)
- K. Highway Business District (B-3)
- L. General Business Dense Development District (B-4)
- M. Transitional Business District (B-5)
- N. Light Industrial District (I-1)
- O. Heavy Industrial District (I-2)
- P. Industrial Park (I-3)
- Q. Amusement & Entertainment District (AED)
- R. Conservation and Flood Plain Overlay District (CFO)

2.4 DISTRICT CLASSIFICATIONS - GENERAL

Territory under the jurisdiction of the Area Plan Commission is divided into the following general land use classifications.

2.4.1 Agricultural districts

The primary use of land throughout much of the unincorporated area of White County is agricultural in nature. The A-1, A-2, and RR agricultural districts are hereby established to protect prime farmland and encourage agricultural industries, for the purpose of preserving the local economy. All residential development within the following agricultural districts should be limited in scale and density.

2.4.2 Residential districts

Conventional residential zoning districts are intended for residential dwellings and related recreational, religious, and educational facilities as these related land uses are typically viewed as providing a balanced and attractive residential neighborhood. Residential areas are typically defined so as to be protected from the encroachment of non-residential uses that are not conducive to a residential environment. Consideration is given to the proper functional relationship and arrangement of each residential district. The L-1, R-1, R-2, R-3, and R-4 residential districts are intended to protect the integrity, value, and enjoyment of use of the dwellings in each district, while also providing a variety of housing types throughout the county.

2.4.3 Non-residential districts

Conventional non-residential districts are intended to provide for commercial and industrial uses to provide for a balanced and prosperous community. The B-1, B-2, B-3, B-4, B-5, I-1, I-2 and AED non-residential, non-agricultural districts are intended to broaden the tax base and further support community services, while creating jobs and providing goods and services to the residents and businesses of White County.

2.4.4 Overlay districts

An overlay district is a semi-transparent zoning district that is placed on top of one or more underlying existing zoning districts. The presence of the overlay district means that there are additional standards and restrictions with which development within that area must comply. Landowners within an overlay district must first comply with the provisions of the underlying, base zoning district and then the provisions of the overlay district. Overlay districts are typically used to: (1) create a location for premier or targeted businesses; (2) unify streetscape and architecture without monotony; (3) control traffic problems and/or signage; (4) require open space and landscaping. In any instance, the requirements of an overlay district may be more or less restrictive than the underlying base zoning district. In addition to bulk use standards, overlay districts typically govern the following types of standards and regulations: lighting, signage, access points on major roads, uses, accessory buildings, architectural design, landscaping, storage and loading areas, and parking.

2.5 STANDARDS AND REGULATIONS BY DISTRICT

Included on the following pages are descriptions of the intent of each zoning district governed by this Ordinance and any additional regulations and/or standards that apply to parcels within a given district.

2.5.1 A-1 General Agricultural District

A. Purpose and Intent

White County is one of the largest crop producers across the State of Indiana. The purpose of the A-1 General Agricultural District is to provide for and protect substantial areas of contiguous land where little or no urbanization has occurred or is planned to occur. It is the intent of this district to limit residential uses, thereby discouraging the development of residential subdivisions, in order to provide for adequate land which is necessary to protect the farming industry and overall economy of White County.

B. Additional standards and regulations

All applicants, developers, landowners who develop any use in any district which abuts an A-1 district shall be required to enter into an agreement acknowledging the County's Right to Farm Ordinance provisions.

For subdivision of a parcel into new parcels, lots or tracts refer to the White County Subdivision Control Ordinance.

For CFO or CAFO operations see Chapter 3 for additional developmental and use standards.

2.5.2 **A-2 Agricultural Industry District**

A. Purpose and Intent

The purpose of the A-2 Agricultural Industry District is to provide adequate land for more intense agricultural uses and agricultural related industries. This includes, but is not limited to: confined feeding operations, digesters and livestock auction yards. Residential subdivisions are prohibited in order to prevent conflicts with the otherwise intense uses intended for an A-2 District. Physical separation between an A-2 District and other residential and non-residential districts may also be necessary in order to further reduce conflicts between otherwise incompatible land uses, to the extent that all future A-2 Districts will require a rezoning to provide for an additional layer of review for the purposes of adequately addressing any issues specific to a proposed use.

B. Setbacks

For the purpose of satisfying the setback requirements of this Section, any building or structure used in conjunction with an existing Digester or CFO/CAFO, shall be allowed to expand or reconstruct facilities, their zoning district boundaries and/or operations as long as such expansion or reconstruction occurs no closer to the setback standards than those physically in place as of July 1, 2016 or as provided below, whichever are least restrictive.

The setback requirements established by this Section shall not be applied to any new residential construction or rezoning occurring after July 1, 2016, excluding reconstruction on a site with existing residential use.

1. Those structures used in confined feeding operations, auction yards and digester operations shall have a setback of one thousand three hundred twenty (1,320) feet from any other non-agricultural district, residence or business, unless located on the same property.
2. The District cannot be located within one (1) mile of an incorporated municipality or the unincorporated town areas of Idaville and Buffalo utilizing such boundary lines as provided for on the White County Official Zoning Map.
3. The District cannot be located within one and one-half (1 ½) miles from any Lake Shafer, Big Monon, Tippecanoe River or Lake Freeman shoreline boundary as provided for on the White County Official Zoning Map.
4. The District cannot be located within one thousand seven hundred sixty (1,760) feet from the property line of any parcel of land legally platted within a recorded subdivision and which subdivision has at least six (6) lots developed with residential dwelling units.

C. All A-2 District uses must provide documentation demonstrating compliance with all Local, State and Federal laws, codes and ordinances including valid permits in cases where permits are required prior to issuance of any Improvement Location Permits or Building Permits.

D. All applicants, developers, landowners who develop any use in this district or within one (1) mile of this district shall be required to enter into an agreement acknowledging the County's Right to Farm Ordinance provisions.

E. Major drainage system and water wells shall be in compliance with IDEM standards.

F. Setbacks shall not apply to fences for areas where animals graze.

G. For subdivision of parcels into new parcels, lots or tracts refer to the White County Subdivision Control Ordinance.

H. Right to Waiver:

The setback standard for "distance to a residence", provided for in Subsection 3.17.1 & 2.5.2 B. 1 of this Ordinance, is subject to waiver under the guidelines provided for in this Section. A parcel with a waiver exempts the residence which is located upon that parcel from consideration in determining compliance to the standards established by Subsections 3.17.1 & 2.5.2 B. 1 of this Ordinance.

For the purposes of this section, a "Subject Parcel" is defined as:

- 1) A parcel of land designated with an A-2 District zoning assignment;
- 2) A parcel of land for which a rezone petition to change a parcel of land to an A-2 District zoning assignment has been officially filed with the Area Plan Department; or,
- 3) A parcel of land with an A-1 District zoning assignment and upon which a confined feeding operation has been grandfathered.

A) The owner of a Subject Parcel may request a waiver for a parcel of land with a unique Parcel Identification Number; hereafter referred to as a "PIN Parcel", under the following conditions:

1. The owner of the PIN Parcel is an individual or entity with legal connections to the Subject Parcel and/or its land use;
2. The PIN Parcel must be utilized, at least in part, for residency purposes;
3. The PIN Parcel must be designated with an RR, A-1 or A-2 zoning district;
4. Only one (1) PIN Parcel can be granted waiver rights in association with any given Subject Parcel;
5. The Waiver request must be submitted to the Area Plan Department on a form approved by the Staff; and,
6. Upon approval of the request by the Staff, the form must be recorded in the White County Recorder's Office by a party affiliated with the request and a copy of the recorded document provided to the Staff, all expenses of which are the responsibility of the party requesting the waiver.

A Waiver runs with the land until such time as an owner of the affected property revokes the Waiver via written notification to the Area Plan Department. Revocation of the Waiver does not affect a District assignment or Confined Feeding facilities established during the period of time the Waiver was in effect.

2.5.3 **RR Rural Residential District**

A. Purpose and Intent

The purpose of the RR Rural Residential District is to provide areas of land that will accommodate a variety of less intensive agricultural uses as well as some very low-density single-family residential subdivisions. Subdivisions are preferred over single lot splits to encourage more compact and contiguous development which in turn avoids the stripping out of county roads. While this district is not intended to be located within incorporated municipalities, the residential subdivisions of a RR District should be located near public utilities whenever possible.

B. Additional standards and regulations

As part of the subdivision process, all applicants, developers, landowners who develop a subdivision in this district shall be required to enter into an agreement acknowledging the County's Right to Farm Ordinance Provisions. A notation shall also be placed in covenant documents and on the subdivision plat.

Any subdivisions that have more than 25 lots within a subdivision shall provide at least twenty-five (25) percent open space. Refer to the White County Subdivision Control Ordinance.

Entrance for subdivisions shall be off a county or municipal road.

All driveways for residences located in subdivision shall be located off the subdivision road. No driveways shall be located off a county or municipal road.

For subdivision of parcels to create new parcels, lots or tracts refer to the White County Subdivision Control Ordinance.

2.5.4 **L-1 Lake District**

The purpose of the L-1 Lake District is to provide adequate land for residential development adjacent to lakes, rivers or other bodies of water in White County. The regulations of an L-1 District are intended to accommodate lakefront property while maintaining the scenic beauty and character of the surrounding area. They are further intended to protect properties along the water's edge from erosion. There are no additional standards or regulations for properties located with L-1 Lake District prescribed by this Ordinance.

2.5.5 **R-1 Single-Family Residential District**

The purpose of the R-1 Single-Family Residential District is to provide adequate land for low-density single-family residential uses. It is anticipated that because of the relatively smaller lot sizes all R-1 districts will be located within an incorporated municipality near existing residential areas. Uses within an R-1 District should primarily consist of relatively low-density single-family dwellings, accessory structures, and related recreational, religious, and educational facilities. Any subdivisions that have more than 25 lots within a subdivision shall provide at least twenty-five (25) percent open space. Refer to the White County Subdivision Control Ordinance.

2.5.6 **R-2 Single and Two-Family Residential District**

The purpose of the R-2 Single and Two-Family Residential District is to provide adequate land for single-family and two-family residential uses. It is anticipated that, like the R-1 District, the majority of R-2 Districts will be located within an incorporated municipality near existing residential areas. Uses within an R-2 District should primarily consist of relatively small to medium sized single-family and two-family dwellings, accessory structures, and related recreational, religious, and educational facilities. Any subdivisions that have more than 25 lots within a subdivision shall provide at least twenty-five (25) percent open space. Refer to the White County Subdivision Control Ordinance.

2.5.7 **R-3 Multi-Family Residential District**

The purpose of the R-3 Multi-Family Residential District is to provide adequate land for high-density residential uses. It is anticipated that because of the relatively higher residential density and the requirement that all multi-family development be connected to public sewer and water utilities, all R-3 Districts will be located within an incorporated municipality. Uses within an R-3 District should primarily consist of multi-family dwellings, which may include apartments, condominiums and townhouses. There are no additional standards or regulations for properties located with R-3 Multi-family Residential districts governed by this Ordinance.

2.5.8 **R-4 Mobile & Manufactured Home Park Residential District**

The purpose of the R-4 Mobile Home Park District is to provide adequate land for mobile and manufactured homes. It is anticipated that all mobile and manufactured residential development will be located within a coordinated park/subdivision development. Uses within an R-4 District should consist of those uses which are typically associated with a mobile or manufactured home park/subdivision.

2.5.9 **B-1 Neighborhood Business District**

The purpose of the B-1 Neighborhood Business District is to provide adequate land which will accommodate a mix of uses. It is anticipated that all B-1 Districts will be located in downtown areas of the incorporated municipalities or in commercial areas where a parcel of limited size exist and which is deserving of relieved standards. Uses within a B-1 District are typically centered on personal service needs, local retail needs and institutional/governmental uses, although each downtown is encouraged to identify its niche market. Residential uses located above ground floor uses are also appropriate for a B-1 District. There are no additional standards or regulations for properties located within B-1 Neighborhood Business districts governed by this Ordinance.

2.5.10 **B-2 General Business District**

The purpose of the B-2 General Business District is to provide adequate land for medium to larger scale business and service establishments that provide for the everyday shopping needs of the community. It is anticipated that B-2 Districts will be located near a B-1 District, or at the intersections of primary thoroughfares within or near a municipality. Uses within a B-2 District will vary; however, such uses typically serve the local population as opposed to travelers and motorists.

There are no additional standards or regulations for properties located with B-2 General Business districts governed by this Ordinance.

2.5.11 **B-3 Highway Business District**

The purpose of the B-3 Highway Business District is to provide adequate land for regional business and service establishments which are otherwise intended to serve the travelers and motorists as well as local residents. It is anticipated that all B-3 Districts will be located around an interstate highway interchange or state highway intersection. There are no additional standards or regulations for properties located with B-3 Highway Business districts governed by this Ordinance.

2.5.12 **B-4 General Business Dense Development District**

The purpose of the B-4 General Business Dense Development District is to provide adequate land which will accommodate a mix of uses. It is anticipated that all B-4 Districts will be located in downtown areas of the incorporated municipalities or nearby to the downtown areas but which are dense development areas with characteristics of excessively small lot sizes combined with extreme lot coverage and with one or more shared walls with neighboring developments. Uses within a B-4 District are of a mixed-use nature to provide diversity of use to the downtown areas. It would be expected to have residential and commercial business uses of a wide variety located within a B-4 District. There are no additional standards or regulations for properties located within B-4 General Business Dense Development Districts governed by this Ordinance.

2.5.13 **B-5 Transitional Business District**

The purpose of the B-5 Transitional Business district is to provide for a commercial district which limits site uses to relatively low-level commercial activities. This district is designed to serve as a transition district between residential and more intrusive or high intensity commercial or industrial districts thus providing a buffer to residences and residential neighborhoods. B-5 district uses would be restricted to those types of commercial activities which operate in a manner which is less of a nuisance to the uses allowed in a residential district thereby keeping more incompatible commercial and industrial uses from directly abutting residential areas. Considerations which should be taken into account for uses which should not be targeted for this district designation are those which have late night hours, commonly generate high noise levels, are geared toward adult-only venues, commonly have outside storage or outdoor operational activities, involve use of hazard chemicals, generate hazardous waste or have other aspects which are disruptive to or incompatible with a residential, neighborhood character. These districts should be restricted to locations where some uses of the general business district assignment could have a significant, negative impact on abutting or nearby residential properties.

2.5.14 **I-1 Light Industrial District**

The purpose of the I-1 Light Industrial District is to provide adequate land for less intensive industrial uses. It is anticipated that I-1 Districts will be located so as not to impede residential development. Uses within an I-1 District may include warehousing, office parks, bio-technology research and light manufacturing processes. The processing or manufacturing of materials or products from extracted or raw materials is

strongly discouraged. To the extent possible, uses within an I-1 District should not be noxious or injurious to the surrounding areas by reason of emission or creation of noise, vibrations, smoke, dust or other particulate matter, toxic or noxious materials, odors, fire, explosive hazard, glare or heat. There are no additional standards or regulations for properties located with I-1 Light Industrial districts governed by this Ordinance.

2.5.15 **I-2 Heavy Industrial District**

The purpose of the I-2 Heavy Industrial District is to provide adequate land for more intense industrial uses. This includes, but is not limited to: the basic processing and manufacturing of materials or products predominately from extracted or raw materials; or are engaged in the storage or manufacturing processes using flammable or explosive materials, or storage or manufacturing processes that potentially involve hazardous or commonly recognized offensive conditions. It is anticipated that all I-2 Districts will be located so as to be buffered from any adjacent district. There are no additional standards or regulations for properties located with I-2 Heavy Industrial districts governed by this Ordinance.

2.5.16 **I-3 Industrial Park District**

The purpose of the I-3 Industrial Park district is to provide standards for the Industrial Park properties identified as part of the planned Mid-America Commerce Park area, including current and potential future areas.

A. The intent of the I-3 District is to provide for an industrial area with standards which accomplish the following:

1. Avoidance of pitfalls typically associated with interstate interchange development;
2. Assure development meets aesthetic and design quality objectives;
3. Encourage economic development and job growth as required to support advanced manufacturing and logistics industry requirements;
4. Establish a thriving business gateway to the greater White County community;
5. Protect the natural amenities of the Mid-America Commerce Park;
6. Promote well planned development of the I-3 District area;
7. Encourage and protect the capital investment of those companies desiring to locate and create jobs within White County;
8. Create a cohesive campus-like business park; and,
9. Establish resolution procedures for regulation conflict.

2.5.17 **AED Amusement and Entertainment District**

The purpose of the Amusement and Entertainment District (AED) is to provide adequate land which will accommodate a mix of intensive recreation, resort and entertainment uses in one district with the intent of preserving the tourist benefit of the AED District. The overall size, hours of operation, the wide range of uses and associated activities has the potential to negatively impact surrounding properties.

The AED District accommodates these activities and provides flexibility in the expansion and continued use of the land.

A. Location

The district shall have frontage on and access to a roadway with adequate capacity to handle any increase projected in traffic flow, both increased levels and type of traffic expected.

B. Site enclosures

Any main amusement park or primary use area shall be enclosed by a minimum of six (6) foot woven-wire or solid fence. Off-street parking areas need not be included within the fenced in area.

C. Signs

All signage within an Amusement and Entertainment District are exempt from the signage regulations of this Ordinance.

D. Lighting

All lighting shall be reflected away from adjacent districts. Downward lighting shall be used on all lights used for signs, pathway and general lighting.

E. Federal and State Approval

Uses in this district shall comply with any and all federal and state regulations.

2.5.18 Overlay Districts

As prescribed in Chapter 6, Overlay Districts, of this Ordinance.

CHAPTER 3 SPECIFIC USE REQUIREMENTS AND PERFORMANCE STANDARDS

3.0 LOT REQUIREMENTS

The following specific lot requirements shall apply in all zoning districts governed by this Ordinance.

3.0.1 Lots

The following requirements shall apply to all lots within the jurisdiction of this Ordinance.

3.0.2 Number of principal buildings per lot

In any district, no more than one (1) principal building and its customary accessory structures shall be located on a single lot of record, with the following exceptions:

- A) Multi-family residential projects where the buildings are designed and platted as a single operating unit under single ownership and control.
- B) Commercial, agricultural or industrial uses commonly configured with multiple buildings having the same purpose. This includes, but is not limited to, self-service storage facilities, boat storage operations, other storage use sites, combined industrial operations and confined feeding operations.
- C) Subordinate Dwelling Unit

In addition to the subordinate dwelling unit regulations found in Chapter 14, Appendix A and Appendix B of the White County Indiana Zoning Control Ordinance, the following standards, regulations and requirements must be met but which may be subject to Variance approval by the Area Board of Zoning Appeals.

- 1) Lot coverage, as defined in Chapter 14, cannot exceed sixty percent (60%);
- 2) Lot size must be a minimum of twelve thousand (12,000) square feet;
- 3) Each dwelling unit must have a unique and separate ingress/egress drive to the street/road rights-of-way;
- 4) Each dwelling unit must have its own well or be connected to a public water system; and,
- 5) Each unit must have its own septic or be connected to a public waste water line; public waste water entity includes Twin Lakes Regional Sewer District.

The following prohibitions apply to properties which include both a principal and subordinate dwelling unit:

- 1) No property which includes a principal and subordinate dwelling unit may also include a duplex, apartment or accessory apartment; and,
- 2) Neither the principal or subordinate dwelling unit may be used for short term rental purposes.

In these cases, all subject buildings must meet the principal structure developmental standards for the applicable zoning district and be utilized for the same use category.

3.0.3 Division of lots

No lot shall hereafter be divided into two (2) or more lots for the purpose of transfer of ownership, unless the division conforms to the applicable regulations of the White County Zoning and Subdivision Control Ordinances.

3.0.4 Corner lots

A lot located at the corner of two (2) or more streets shall treat each yard that faces a street as a front yard. In which case, each yard facing a street shall be subject to the applicable front yard setbacks and all other applicable requirements thereof. Therefore, the side and rear yards may be transitional and must be declared at the time of application.

3.0.5 Street frontage and access

Every lot must have frontage on a public street and must be provided with traffic access points for adequate ingress and egress to and from such public street. All lots having one hundred (100) feet or less of frontage shall have a maximum of one (1) ingress and egress point. A private road may be used in lieu of public streets for frontage provided the layout and design of such road is approved by the Area Plan Commission.

3.0.6 Lot area exclusions

Any portion of any lot located within a 100-year floodplain, a floodway, wetland, lake, pond, storm water detention area, or an area used for floodplain compensatory storage, may not be counted towards the applicable minimum lot area requirement.

3.0.7 Vision clearance triangle

No building, structure, or improvement, including landscaping, shall be erected, placed, planted or maintained within a Vision Clearance Triangle (see below) so as to interfere with a vision clearance area; the vision clearance area is the area of space within a Vision Clearance Triangle between the heights of two and one half (2 ½) feet and twelve (12) feet above the crown of a street, driveway or alley. With the exception of official warning signs or signals necessary for public safety, a vision clearance triangle shall be established for all streets whether public or private, driveways, railroad crossings and alleys as prescribed in (A) through (D) below.

A. Street/Road Intersection

Unless excluded elsewhere in this Ordinance, a property abutting a street/road intersection is subject to a vision clearance triangle. The vision clearance triangle is triangular shaped with two sides being formed by the street right-of-way lines and the third side being the line connecting points twenty-five (25) feet from the intersection of such street right-of-way lines, or in the case of a round or cut property corner, from the intersection of the street right-of-way lines extended.

See Figure 3.1 (a) & (b) for examples

Figure 3.1 (a) & (b) – Vision Clearance Triangle; Street & Road Intersections

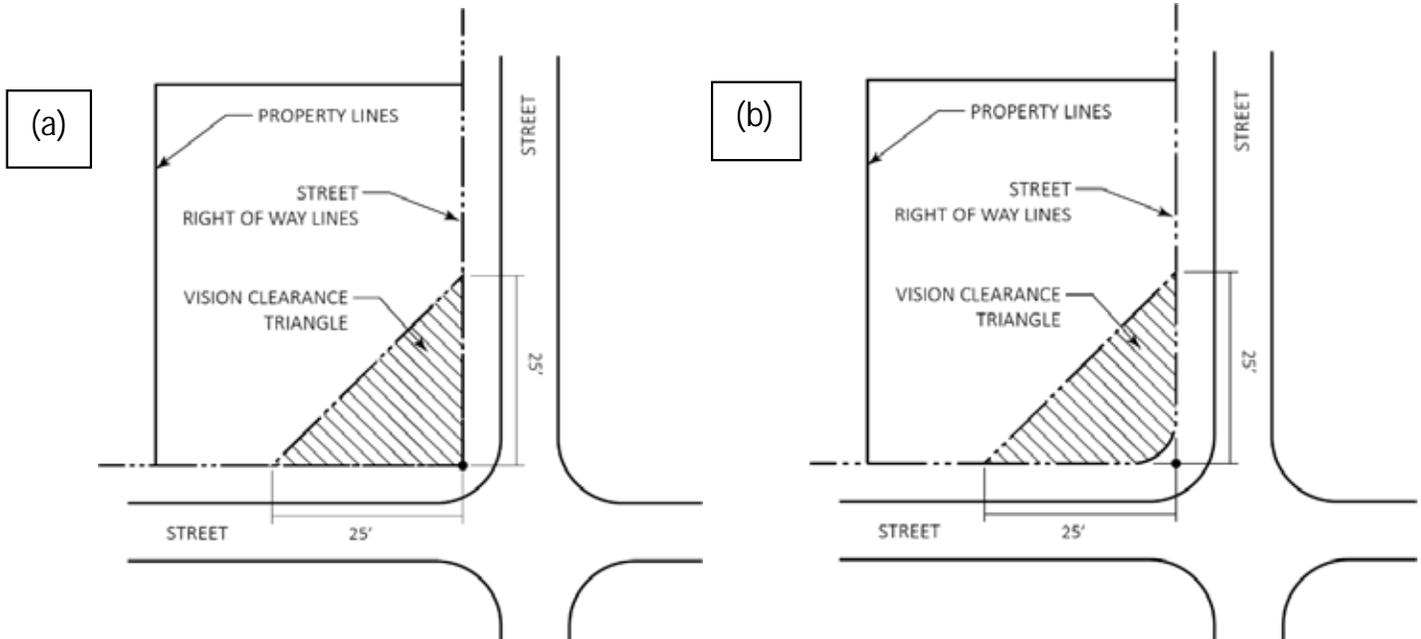

B. Land adjacent to an at-grade railroad crossing

Unless excluded elsewhere in this Ordinance, land adjacent to an at-grade railroad crossing is subject to a vision clearance triangle. The vision clearance triangle is triangular shaped beginning at the point of intersection of the street/road right-of-way and the railroad right-of-way, then extending along each right-of-way line a distance of twenty-five (25) feet to two end points. The end points are then connected to create a third line thus establishing the vision clearance triangle.

See Figure 3.2 for an example.

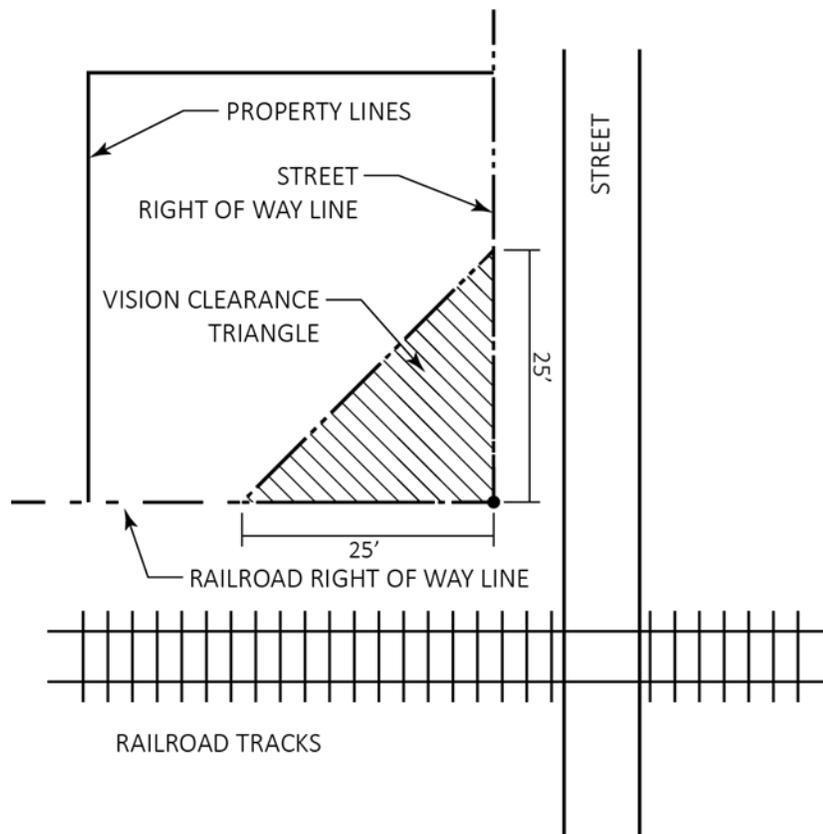
Figure 3.2 – Vision Clearance Triangle; Adjacent to A Railroad Crossing

C. Street/Road & Alley Intersections

Unless excluded elsewhere in this Ordinance, all street/road and alley intersections are subject to a vision clearance triangle. The vision clearance triangle is triangular shaped, one side of which is formed by the street right-of-way line, the second side of which is formed by the alley right-of-way line. The third side is formed by connecting the two points twenty-five (25) feet from the intersection of the two sides formed by the street/road and alley right-of-way sides.

See Figure 3.3 for an example.

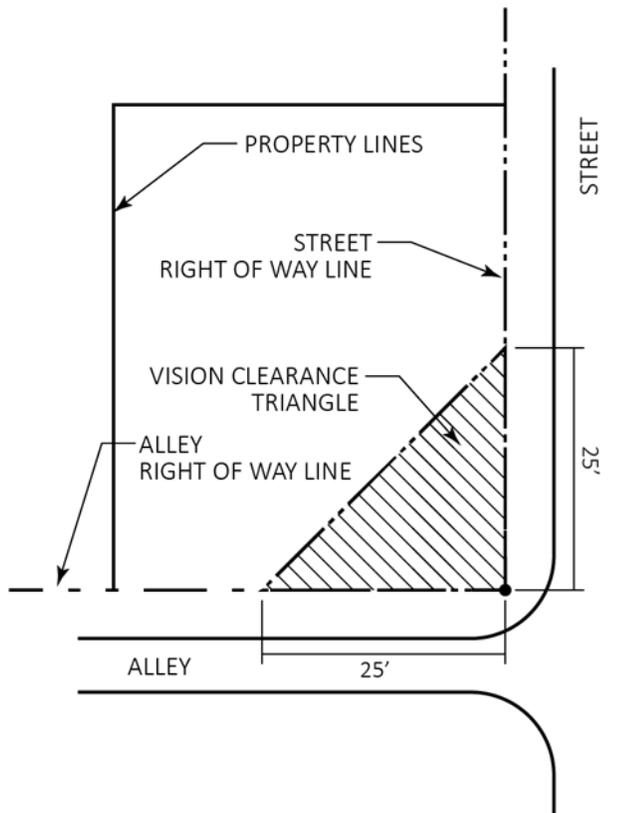
Figure 3.3 – Vision Clearance Triangle; Street or Road & Alley Intersection**D. Driveway**

Unless excluded elsewhere in this Ordinance, each driveway shall maintain a vision clearance triangle. The vision clearance triangle is triangular shaped, one side of which is formed by the edge line of the driveway, the second side of which is formed by the street/road right-of-way line. The third side is formed by connecting the two points twenty-five (25) feet from the intersection of the two sides formed by the street/road right-of-way line and the edge line of the driveway. The vision clearance triangle requirement applies to both edge lines of the driveway. In the case of vision clearance triangles for driveways, the vision clearance triangle stops at the subject property's property line.

See Figure 3.4 for an example.

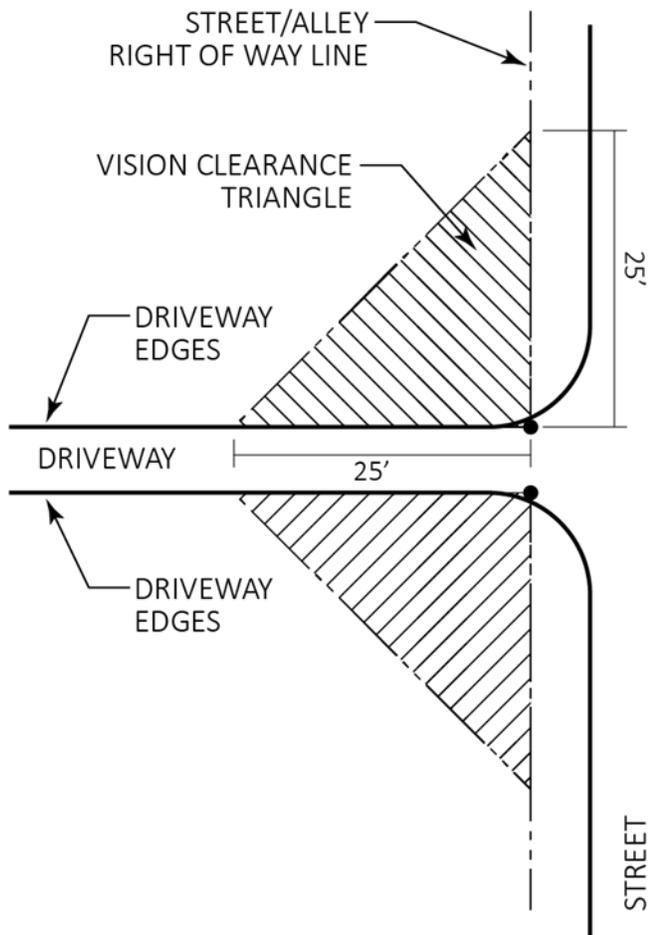
Figure 3.4 – Vision Clearance Triangle; Driveway

3.1 HOME OCCUPATIONS

All home occupations must satisfy the requirements of this Chapter in addition to any standards or regulations found elsewhere in this Ordinance.

3.1.1 Purpose and scope

It is the intent of this Section to regulate all home occupation uses. The standards of this Section are intended to ensure compatibility of home occupations with the residential character of any neighborhood establishing them as a clear secondary or incidental use to the permitted residential use of the principal structure. For the purposes of administering and enforcing this Section, a home occupation exists if an owner, lessee, or other person legally residing in a residential dwelling is also conducting a legitimate business from the home or property. Such home occupation shall be subject to the conditions and requirements of this Section.

3.1.2 Required conditions

In general, home occupations are permitted accessory uses in any residential or A-1 district, provided that said home occupation complies with the following:

A. Such occupation shall be conducted solely by occupants residing at the residence. Upon approval of the Area Board of Zoning Appeals, a business which has employees, other than the occupants, where the primary activities are conducted at other locations (such as a building contractor) and where employees are on-site for incidental purposes only (such as being scheduled for their assignment location or to receive work orders) may be treated as a home occupation if the Area Board of Zoning Appeals determines all other home occupation criteria will be met and that the on-site activities related to the employees will not result in a detrimental effect or nuisance to the neighborhood.

B. The use of the dwelling unit for the home occupation shall clearly be incidental and subordinate to the principal use of the structure as a residential dwelling, to the extent that no more than twenty-five (25) percent of the gross floor area of the dwelling unit, including any accessory buildings, may be used for the conduct of the home occupation.

C. Home occupations may be located in either the dwelling unit or accessory building, but not both.

D. No home occupation use shall require internal or external alterations or involve construction features or the use of electrical or mechanical equipment that would change the fire rating of the residential dwelling or accessory structure, or the fire district in which the structure is located;

E. There shall be no outdoor storage of any kind which is related to the home occupation;

F. Only one (1) nameplate sign and one (1) yard sign shall be allowed regardless of the number of streets that the property faces. The nameplate sign may display the name of the occupant and/or the name of the home occupation. The nameplate sign may be attached flat to the principal structure or placed so as to be visible from the street through a window. The nameplate sign shall be no greater than three (3) square feet in area. The yard sign shall have a face no greater than six (6) square feet and not taller than five (5) feet in overall height. No such sign shall be illuminated.

G. No home occupation shall generate more traffic or parking capacity requirements or otherwise cause the local traffic volume to increase, than would normally be expected or appropriate in a residential neighborhood wherein no home occupation exists. All excess parking needs generated by the home occupation beyond what's readily available, shall be met by the off-street parking requirements as specified in this Ordinance, provided that in no instance shall parking for a home occupation be allowed to occur in a required front yard setback.

H. No home occupation use shall create noise, dust, vibration, smell, smoke, glare, electrical interference, fire hazard, or any other hazard or nuisance to any greater or more frequent extent than is expected or appropriate in a residential neighborhood wherein no home occupation exists. In the case of electrical interference, no

equipment or process shall be used which creates visual or audible interference in any radio or television receivers or causes fluctuations in the line voltage off-site.

I. No home occupation shall involve the use of commercial delivery vehicles for the transport of materials to or from the premises, with the exception of delivery vehicles which are typically associated with residential home delivery, such as postal or parcel vehicles.

J. No home occupation shall cause a nuisance to the residential neighborhood in which it exists.

3.1.3 Uses that are prohibited as home occupations

The following uses by the nature of the investment or operation have a pronounced tendency once started to rapidly increase beyond the required provisions of a home occupation and thereby impair the use and value of a residentially zoned area.

Therefore, the following uses shall not be permitted as home occupations:

Auto/vehicle repairs, minor or major;

Gift shops;

Dance studio;

Dental clinic;

Freight, trucking, or shipping;

Unlicensed Massage Parlors (no Indiana State License);

Medical clinic;

Painting of vehicles, trailers, boats, etc.;

Retail photo developing;

Private schools with organized classes;

Restaurants, eating or drinking establishments;

Tattoo Parlors;

Tooling, welding or machinery shops;

Tool or equipment rental;

Veterinary clinic, kennel, or stables; or

Any other uses not meeting the conditions of this Section as determined by the Executive Director.

3.1.4 Examples of uses that frequently qualify as home occupations

Accountants;

Artists and sculptors;

Authors and composers;

Barber shop;

Beauty shop;

Dressmakers, seamstresses and tailors;

Child care limited to no more than five (5) children.

Individual tutoring;

Individual music, dancing, or singing lessons;

Office facility of a member of the clergy

Office facility of a sales person, sales representative, or manufacturer's representative provided that no exchange of retail or wholesale merchandise is made on or adjacent to the premises;

Office facility of a professional such as a plumber, electrician, appraiser, architect, engineer, lawyer, insurance agent, land surveyor, real estate agent, consultant, etc.;

Traditional full or part-time sales occupations;

Appliance, television, radio, lawn mower or bicycle repair;

Photography studio, one client at a time;

Upholstering;

Massage Therapy (Indiana State Licensed); or

Any other use that complies with all of the restrictions and conditions of this Section as determined by the Executive Director.

3.1.5 Professional offices – special restrictions

A physician, dentist, lawyer, member of the clergy, engineer, insurance agent, real estate agent, consultant, or other professional person may use his/her residence for office work, consultation, emergency treatment, or performance of religious rites, but not for the general practice of his profession and not for the installation or use of any mechanical or electrical equipment customarily incidental to the practice of any such profession.

3.1.6 Child care homes - special restrictions

The restrictions of Subsection 3.1.6 apply to Child Care Homes whether operating as a home occupation or out of a residential structure not used as a dwelling.

1. In any residential district where a Child Care Home operates, each parcel is restricted to one (1) Child Care Home license.
2. A Child Care Home and a Child Care House may not operate on the same parcel.

3. No two residential district parcels, upon which facilities are used, or are planned to be used, to operate a Child Care Home, may be located any closer than five hundred (500) feet, as measured in a straight line, without regard to intervening structures or objects, between the closest parcel lines of each parcel.
4. All residential district parcels used or intended to be used for a Child Care Home must install a 6' foot, opaque privacy fence along any property line abutting a residential district which is used for dwelling purposes.
5. A Child Care Home, as defined in Chapter 14, Definitions, when operating on the same parcel upon which a dwelling is located, shall meet all requirements of a home occupation as set forth in this Chapter with the exception of those standards which are inconsistent with state licensure requirements as contained in Indiana Code 12-7-2-33.7 and 12-7-2-33.8 as amended.
6. A Child Care Home shall meet all requirements for licensure under state law, and shall be operated in such a manner as to maintain the residential nature of the neighborhood in which it is operated.

All Child Care Homes legally operating as of January 1, 2016 and not in compliance with the standards required of this Ordinance, will be provided legal non-conforming status until such time as one of the disqualifying events listed below occurs.

Disqualifying Events:

- a. Child Care Home activities cease for a period of six (6) months or more;
- b. A Child Care Home has its license:
 - 1) revoked by the appropriate State agency;
 - 2) lapse;
 - 3) re-licensed under a person or entity name other than the name under which the license operated at the time of adoption of this Ordinance Amendment;
- c. Title of the property is transferred to another party.

Upon occurrence of one of the "Disqualifying Events", a Child Care Home shall cease operation or be brought into compliance with current Ordinance requirements. Failure to execute one of the actions above will be considered a civil zoning violation and subject the site to enforcement proceedings as provided for by Ordinance.

The Child Care Home may have such employees as required by state law or regulation, and may operate in that part of the residence necessary to meet licensure requirements.

The Child Care Home shall operate in such a fashion as not to cause abnormally unsafe or disruptive vehicular traffic congestion in the day care home neighborhood. On-street parking of employees shall be limited to two (2) parked vehicles during the child care operating hours but only for locations where the parcel of the Child Care Home abuts a street where on-street parking is allowed and where the parking allowance is not in conflict with any other standard or requirement of this Ordinance.

3.2 **BED AND BREAKFAST ESTABLISHMENTS**

In addition to all applicable requirements of the Indiana Building Code, bed and breakfast establishments, where allowed, shall adhere to the following requirements.

3.2.1 **Location**

Bed and breakfast establishments shall only be located within a single-family home occupied by the owner or a live-in manager whom is on the premises when occupied by guests.

3.2.2 **Health regulations**

Bed and breakfast establishments shall comply with all applicable local, county and state fire and health regulations.

3.2.3 **Ancillary commercial use prohibited**

No ancillary commercial use shall be operated in connection with any bed and breakfast establishment.

3.2.4 **Classification of use**

The operation of a bed and breakfast establishment shall not be considered or classified as a home occupation.

3.2.5 **Number of rooms permitted**

The number of rooms permitted in any bed and breakfast establishments shall be as prescribed by the Indiana Building Code.

3.2.6 **Length of stay**

No guest of a bed and breakfast establishment may stay longer than thirty (30) consecutive days.

3.2.7 **Operator requirement**

The operator of the establishment shall reside within the bed and breakfast establishment or within some other approved dwelling located on premises adjacent to said establishment.

3.2.8 **Parking requirement**

Parking for any bed and breakfast establishment shall be in accordance with Chapter 8, Parking and Loading Standards.

3.3 **MANUFACTURED AND MOBILE HOMES**

Any manufactured home or mobile home permitted within the jurisdiction of the White County Plan Commission shall have been constructed on or after January 1, 1981. These general manufactured home and mobile home requirements shall apply to all

zoning districts where a manufactured home or mobile home is permitted under Appendix A, Official Schedule of Uses, and to manufactured homes and mobile homes permitted under section 4.5.8 of this ordinance. The establishment, location, and use of all manufactured homes and mobile homes shall meet the installation instructions of the manufacturer, and all standards set forth in Appendix B and minimum parking requirements for single-family dwellings. They shall also meet the requirements in Sections 3.3.1 or 3.3.2, whichever shall apply.

3.3.1 **Type I Manufactured Homes**

Living area

All Type I Manufactured Homes shall have, in a double section or larger, multi-section unit living area no less than the minimum required for the district in which it is intended to be located.

Foundation

All Type I Manufactured Homes shall be placed on a permanent foundation which is to include an exterior perimeter block retaining wall that is consistent with those for, or planned for, other homes in the area. They shall be installed consistent with the manufacturer's installation instructions and comply with all applicable provisions of the local Building Code.

Anchoring

All Type I Manufactured Homes shall be anchored to the ground in accordance with the manufactured home's installation requirements and the local Building Code.

Travel equipment

All travel equipment; including wheels, axles, and hitch mechanisms shall be removed upon placement of any Type I Manufactured Home.

Utilities

All Type I Manufactured Homes shall meet utility connection requirements in accordance with the manufactured home's installation requirements and the local Building Code.

Siding material

All Type I Manufactured Homes shall have siding material of a type similar to, or otherwise compatible with that which is found on other dwellings in, or planned for, the area.

Roofing material

All Type I Manufactured Homes shall have roofing material of a type similar, or otherwise compatible with, that which is found on other dwellings in, or planned for, the area.

3.3.2 **Type II Manufactured Homes**

Living area

All Type II Manufactured Homes shall have a minimum of eight hundred and fifty (850) square feet of living area in a single, double, or multi-section unit, including those with a pullout or tag-along unit.

Foundation

All Type II Manufactured Homes located in any R-1 (single family residential) or R-2 (single and two-family residential) zoning district shall be placed on a permanent foundation which is to include an exterior perimeter block retaining wall that is consistent with those for, or planned for, other homes in the area. They shall be installed consistent with the manufacturer's installation instructions and comply with all applicable provisions of the local Building Code.

Anchoring

All Type II Manufactured Homes shall be anchored to the ground in accordance with the manufactured home's installation requirements and the local Building Code.

Travel equipment

All travel equipment; including wheels, axles, and hitch mechanisms shall be removed upon placement of any Type II Manufactured Home.

Utilities

All Type II Manufactured Homes shall meet utility connection requirements in accordance with the manufactured home's installation requirements and the local Building Code.

3.4 **TEMPORARY MANUFACTURED OR MOBILE HOMES**

The temporary use of a Type II manufactured home or a mobile home shall be permitted as prescribed by Appendix A, Official Schedule of Uses, provided that the temporary use complies with this Section.

3.4.1 **Temporary residence during home construction**

A Type II manufactured home or mobile home may be used as a temporary residence during the construction or renovation of a single-family dwelling on the lot for which a permit to construct or renovate said single-family dwelling has been obtained.

Permits required

A Special Use Permit and an Improvement Location Permit for a temporary structure shall be obtained prior to the installation of the manufactured or mobile home.

Expiration

Both permits shall expire with the approval of the Occupancy Permit for the permanent residence, or two (2) years from the issuance of the temporary Improvement Location Permit, whichever comes first.

Location and access

The temporary residence shall conform to the setback requirements for the district in which it is located. In addition, the temporary residence shall be accessible by the same driveway as the permanent residence.

Removal plan

At the time of application, the applicant shall provide a detailed plan for the subsequent removal of the temporary residence. The removal plan shall include the intended location of disposal or relocation, as well as an estimated cost for disposing or relocating said residence.

3.4.2 Temporary residence for a care-giver/dependent relative

A Type II manufactured home or mobile home may be used as a temporary residence for either an individual providing care to a dependent relative or a dependent relative in need of continuous, on-site care.

Permit required

A Special Use Permit and an Improvement Location Permit for a temporary structure shall be obtained prior to the installation of the manufactured or mobile home.

Expiration

Both permits shall expire at the time the dependent relative no longer requires continuous, on-site care.

Location and access

The temporary residence shall be located on the same lot as the permanent residence of the other individual in the dependent/care-giver circumstance. The temporary residence shall conform to the setback requirements for the district in which it is located. In addition, the temporary residence shall be accessible by the same driveway as the permanent residence.

Removal plan

At the time of application, the applicant shall provide a detailed plan for the subsequent removal of the temporary residence. The removal plan shall include the intended location of disposal or relocation, as well as an estimated cost for disposing or relocating said residence.

3.5 MOBILE HOME PARKS AND SUBDIVISIONS

It shall be unlawful for a person to keep, store, or maintain any mobile home park or subdivision within the County's jurisdiction that does not comply with the requirements of this Ordinance. All mobile home parks and subdivisions shall comply with this Section.

3.5.1 Entrances and interior roads

All interior streets shall either be dedicated to the public or be private interior drives. All interior streets, regardless of ownership, shall meet the design and construction standards of the White County Subdivision Control Ordinance. If private streets are used, street easements shall substitute for the interior street right-of-way.

3.5.2 Compliance verification

Prior to the issuance of an Improvement Location Permit and prior to the construction of the park or subdivision, the following shall be submitted to the Executive Director.

Access

A letter from the appropriate municipal or county engineer of jurisdiction, verifying the approval of the design of access point to public streets.

Sanitary Sewer Service

A letter from the appropriate sewer utility, verifying that adequate sanitary sewer service shall be available to the homes.

Board of Health

A letter from the Indiana State Board of Health verifying that all applicable requirements have been or shall be met.

3.6 CAMPGROUNDS

3.6.1 Minimum Size

The minimum size of a recreational campground shall be five (5) acres. The design, installation, and maintenance shall be as required by the Indiana State Board of Health.

3.6.2 Occupation of tents, cabins and recreational vehicles

Recreational vehicles, cabins and tents are allowed in and may be occupied in any campground. Recreational vehicles shall not be occupied in any location other than an approved mobile home park or AED zoning district except where expressly permitted by this Ordinance.

3.6.3 Campground standards

All campgrounds shall meet the following standards:

Campgrounds shall have direct access to a public street with sufficient frontage thereon for the proper construction of entrances and exits that are designed for the safe movement of recreational vehicles into and out of the campground.

The density of a campground shall not exceed thirty-six (36) recreational vehicle spaces per one (1) acre of gross site area. Gross site area shall include only the land that is designated for camping, exclusive of streets, parking areas, dedicated rights-of-way, and park service facility areas.

Recreational vehicles shall be separated from each other and from other park buildings or structures by a minimum of ten (10) feet.

Where the boundary line of a campground coincides with that of an adjacent residential district where no street or alley separates the two, a buffer shall be required. Said buffer shall be a minimum distance of twenty-five (25) feet in width which contains either a solid fence standing a minimum of eight (8) feet in height, or a solid evergreen hedge.

At least one (1) centrally located recreation area shall be provided in each campground. Said recreational area shall be equal in size to eight percent (8%) of the gross site area, exclusive of streets, parking areas, dedicated rights-of-way, and park service facility areas.

Food stores, restaurants, sporting goods, laundromats, dry cleaners, service stations, and similar convenience and service shops may be permitted in campgrounds containing fifty (50) or more camp sites, provided that such shops and the parking area required by the use shall not occupy more than ten percent (10%) of the total area of the campground.

Management offices and storage, playground and picnic equipment, sanitation and laundry facilities, informational signs and other structures customarily incidental to a campground shall be permitted as accessory uses.

3.7 RECREATIONAL VEHICLE PARK

3.7.1 Minimum size

The minimum size for Recreational Vehicle Parks shall be as follows:

One (1) acre for recreational vehicle parks designed to accommodate twenty (20) or less recreational vehicles spaces at maximum capacity;

Three (3) acres for recreational vehicle parks designed to accommodate between twenty-one (21) and seventy-five (75) recreational vehicle spaces at maximum capacity; and,

Five (5) acres for recreational vehicle parks designed to accommodate greater than seventy-five (75) recreational vehicles spaces at maximum capacity.

The density of any recreational vehicle park shall never exceed thirty-six (36) recreational vehicle spaces per one (1) acre of gross site area. Gross site area shall include only the land that is designated for recreational vehicle parking, exclusive of streets, parking areas, dedicated rights-of-way, and park service facilities.

3.7.2 Entrances and interior roads

Prior to issuance of an Improvement Location Permit and prior to construction of the recreational vehicle park, the following shall be submitted to the Executive Director:

1. Access - A letter from the appropriate municipal or county legislative body verifying the approval of the ingress-egress access design; and,
2. Sewer System - A letter from the appropriate sewer utility, local Health Department or the State Board of Health, whichever applies, verifying the sewer system design meets the requirements for the recreational park design.

3.7.3 Recreational vehicle park standards

All recreational vehicle parks shall meet the following standards:

1. Recreational vehicles shall be separated from each other and from other park buildings or none site required structures, a minimum of 10’;
2. Where the boundary line of a recreational vehicle park coincides with that of an adjacent residential district, where no street or alley separates the two, a buffer a minimum of twenty-five (25) feet is required. The buffer must contain either an eight (8) foot solid fence or a solid evergreen hedge.
3. Food, fuel and sporting goods stores, laundromats, dry cleaners and similar convenience and service shops may be permitted in recreational parks containing fifty (50) or more vehicle sites, provided that such shops and the parking area required by the use shall not occupy more than ten (10) percent of the total area of the recreational vehicle park; and,
4. Management offices and storage, playground and picnic equipment, sanitation and laundry facilities, informational signs and other structures customarily associated with a recreational vehicle park shall be considered incidental, permitted accessory uses.

3.7.4 Site plan requirements

All recreational vehicle park developments must provide a site plan as required by the Staff.

3.8 **SATELLITE DISH ANTENNA**

These regulations shall apply to satellite dish antenna and other satellite reception devices greater than two (2) feet in diameter.

3.8.1 General purposes

The regulations of this Section are designed to promote public health and safety by providing criteria for the placement of these antennas that ensures all such installations are performed in a manner that limits endangerment of life and property on the site and surrounding properties due to collapse or destruction.

These regulations are also designed to decrease the potential for urban blight in residential neighborhoods generated by guy wires, poles, cables, and other appurtenances.

These regulations are intended to allow satellite dish antenna and other satellite reception devices to be located in a manner that: (1) does not unreasonably delay or prevent the installation, maintenance or use of the antenna; (2) does not unreasonably increase the cost of installation, maintenance or use of the antenna; or (3) preclude reception of an acceptable quality signal.

3.8.2 General requirements

No person shall install a satellite dish antenna greater than two (2) feet in diameter without first obtaining an Improvement Location Permit.

All satellite dish antennas shall be installed and maintained in compliance with all applicable building and electrical codes, and shall be subject to the following standards.

1. Satellite dish antennae shall be solid in color.
2. Satellite dish antennae must be permanently mounted.
3. Not more than one (1) antenna greater than two (2) feet in diameter shall be allowed on any lot unless shown on an approved site plan.

Satellite dish antenna may be erected in any residential zoning district provided the following criteria are met.

4. The satellite dish antenna shall be ground mounted.
5. The diameter shall not exceed ten (10) feet.
6. The height of a ground-mounted antenna shall not exceed twelve (12) feet.
7. It shall be located between the rear building line of the principal structure and the required rear yard setback line.
8. In the R-3 Residential District, a satellite dish antenna may be roof mounted provided the diameter does not exceed ten (10) feet, and the height of the antenna does not exceed twelve (12) feet. A roof mounted satellite dish antenna shall be located at least ten (10) feet behind the front roofline of the structure. Notwithstanding the foregoing, a roof-mounted antenna shall not exceed the maximum building height requirement of the zoning district within which it is located.

Satellite dish antenna may be erected in any non-residential zoning district provided the following criteria are met.

9. The diameter shall not exceed twelve (12) feet.
10. The height of a ground-mounted antenna shall not exceed twenty-five (25) feet.
11. The height of a roof-mounted antenna shall not exceed fifteen (15) feet. Notwithstanding the foregoing, a roof-mounted antenna shall not exceed the maximum building height requirement of the zoning district within which it is located. Furthermore, a roof mounted satellite dish antenna shall be located at least ten (10) feet behind the front roofline of the structure.
12. A ground-mounted antenna shall comply with the yard setback requirements of the district within which it is located; however, no antenna shall be located in any required front yard or required open space.

3.9 AMATEUR RADIO ANTENNA

Amateur radio serves the community by providing emergency communications that benefit White County. The County supports these valuable community services and therefore, individual amateur transmitting and receiving antennae and associated support structures owned or operated by licensed amateur radio operators shall be permitted as accessory structures in accordance with these provisions.

Amateur Radio Club and repeater station antennae and support structures are permitted to such a height as necessary to maintain reliable communications.

Antenna structures of amateur radio operators licensed by the Federal Communication Commission (FCC) may, as of right, have a height not exceeding seventy-five (75) feet above grade. The height shall be measured vertically and shall include the height of any building upon which the antenna support structure is mounted.

Antennae may be located above the antenna support structure as reasonably necessary for effective radio communications.

Upon the Federal Communication Commission (FCC) licensed operator's cessation of ownership or leasehold rights in the subject antenna support structure, or on loss of his or her federal amateur radio license (whichever occurs first), the operator shall forthwith (but in no case more than thirty (30) days) safely remove all antenna support structures at no expense to the County. In the event that the operator fails or refuses to remove the antenna support structure, then the owner of the subject lot shall be responsible for the removal of all such structures.

On residential lots, any antenna support structure shall be located in an area between the rear building line of the principal structure and the required rear yard setback line.

Nothing in this Section shall affect any existing antenna support structure utilized by any federally licensed amateur radio operator, which has been constructed and is in place prior to the passage of this Ordinance.

3.10 WIRELESS SUPPORT STRUCTURES AND WIRELESS FACILITIES

3.10.1 Purpose, authority, and jurisdiction

A. Purpose

The purpose of this Section is to regulate the placement, construction, and modification of wireless support structures and wireless facilities in order to protect the public health, safety and general welfare of the community, while accommodating the need for telecommunication services. Regulation of the siting of wireless support structures and wireless facilities is an exercise of valid police power stipulated in the Federal Telecommunications Act of 1996 and delegated by the State of Indiana to local authority as provided for in IC 36-7 and IC 8-1-32.3-18 (1). The developer has the duty of compliance with reasonable conditions laid down by this Ordinance.

B. Written Notice

In all cases where a written notice is required for the purpose of providing an application determination, the written notice shall state clearly the basis for its decision to approve or deny an application. In the case of denial, the written notice must include substantial evidence in support of the denial. For purposes of written notification, minutes of a public meeting of a permit authority satisfies this requirement.

C. Confidentiality

Any information provided as part of an application referenced in this section which an applicant considers confidential or proprietary must be clearly marked as such. These documents will be protected under the departmental guidelines for protection of confidential or proprietary material.

D. Authority

As designated by Section 3.10, the Executive Director, Office Administrator, Area Plan Commission and Area Board of Zoning Appeals are hereby vested with the authority to review and approve/deny applications for the following as provided for in Sections 3.10.2, 3.10.3, 3.10.4 and 3.10.5 of this Chapter:

1. Construction of a new wireless support structure;
2. Collocations of wireless facilities on an existing structure;
3. Substantial modification of a wireless support structure; and,
4. Location of a small cell facility including a micro wireless facility.

For purposes of Section 3.10, the term “application” refers to an Improvement Location Permit (ILP) application and/or Building Permit (BP) application as established by the context of its use.

E. Jurisdiction

These regulations apply to all wireless support structures and wireless facilities as defined in Chapter 14, Definitions, located within the jurisdiction of the White County Area Plan Commission.

F. With the exception of non-commercial wireless facilities, no building mounted communications antennas shall be located on any single-family or two-family dwelling.

G. Approval – Other

Subject to subsection H below, an approval permit or waiver is required from the local highway or street department, whichever is appropriate, any time work is to be performed within a road buffer zone. This permit does not preclude the requirement of obtaining consent from the owner of:

- 1) private property;
- 2) a private utility pole; or,
- 3) a privately-owned wireless support structure.

H. Exclusions

A permit authority may not require an application or a permit for, or charge fees for, any of the following:

- 1) The routine maintenance of wireless facilities.
- 2) The replacement of wireless facilities with wireless facilities that are:
 - (A) Substantially similar to; or
 - (B) The same size or smaller than the wireless facilities being replaced.
- 3) The installation, placement, maintenance or replacement of micro wireless facilities that are suspended on cables strung between existing utility poles in compliance with applicable codes by a communications service provider that is authorized to use the public rights-of-way. For purposes of this subsection, "applicable codes" means uniform building, fire, electrical, plumbing or mechanical codes that are:
 - (A) Adopted by a recognized national code organization; and,
 - (B) Enacted solely to address imminent threats of destruction of property or injury to persons; including any local amendments to those codes.
- 4) The installation, location, or use of wireless service facilities on utility poles or electrical transmission towers.

I. Prohibitions

The Area Plan Department may not require an applicant to submit information about an applicant's business decision with respect to the applicant's designed service, customer demand, service quality or desired signal strength to a particular location, nor may the Area Plan Department evaluate such information.

3.10.2 NEW WIRELESS SUPPORT STRUCTURES AND WIRELESS FACILITIES

3.10.2.1 Application and Approval Procedure

A. Application Review

The Executive Director shall approve/deny completeness of all applications for any new wireless support structure and/or wireless facility. All applications shall be reviewed and determination for completeness made within ten (10) business days from its receipt. If the application is not complete, the Executive Director shall notify the applicant in writing of all defects in the application. Unless notified in writing otherwise, an applicant has thirty (30) days from receiving notice of the application status to cure the defects in the application. If the applicant cannot meet the thirty (30) day period, the applicant shall notify the Staff of the additional time the applicant requires to cure the defects. The Executive Director shall approve or deny the application within ninety (90) days after the

date of the original determination adjusted by any amount of time required by the applicant to cure defects of the application.

B. Application requirements

Any person or entity desiring to establish a new wireless support structure and/or wireless facility, whether a permitted use or a special exception use, is required to apply for and obtain an Improvement Location Permit (ILP) from the Staff. An ILP application, along with all supporting documents, including the applicable filing fee, must be submitted to the Area Plan Office for consideration. It is the responsibility of the applicant to complete the application and provide the information necessary to satisfy all application requirements. Upon determination as complete, the Staff will compile the application packet for presentation to the Area Plan Commission which will consider the application at a scheduled public hearing for approval or denial. Each application must include the following information:

1. The owner/operator's name, business address and point of contact for the applicant;
2. The location (address and parcel #) of the proposed wireless support structure and/or wireless facilities; and,
3. A construction plan that describes the proposed wireless support structure and all equipment and network components, including antennas, transmitters, receivers, base stations, power supplies, cabling and related equipment. Such construction plan shall be certified with an engineer's seal, registration number and signature and include the following information and documents:
 - a) Certification that the proposed installation will not exceed the structural capacity of the wireless support structure taking into consideration wind and other load variables associated with the construction and installation of said structure;
 - b) A layout drawing showing the wireless support structure's height, elevation and construction design;
 - c) Documentation of the steps the applicant will take to avoid interference with established public safety telecommunications;
 - d) A site development plan which meets the requirements and information listed below:
 - 1) Location and approximate size and height of all buildings and structures located within five hundred (500) feet of the proposed wireless equipment compound;
 - 2) A detailed layout of the entire development, indicating all improvements, including all proposed landscaping, screening and access points;
 - 3) Elevations illustrating all facades and indicating exterior materials and color of the proposed wireless support structure; and,
 - 4) Drawings to a scale of no smaller than one (1) inch equals fifty (50) feet;

- e) A copy of the FAA's (Federal Aviation Administration) response to the submitted "Notice of Proposed Construction or Alteration" (FAA Form 7460-1 as amended from time to time);
- f) Certification of compliance with applicable Federal Communications Commission (FCC) regulations;
- g) A Decommissioning Plan meeting the minimum standards of Chapter 3, Section 3.10, Subsection 3.10.2.3 F and satisfactory to the Area Plan Commission or one which has been approved by the governmental entity under which the subject property lies;
- h) A report from a qualified and licensed professional engineer which demonstrates the facilities' design compliance with the State's structural and electrical standards;
- i) If the applicant is not the property owner, a copy of an executed lease agreement or letter of authorization between the applicant and the property owner pertaining to the siting of a wireless support structure and/or wireless facilities on the subject property;
- j) Evidence of agreements and/or easements necessary to provide access to the wireless support structure, building, water tower or other structure on which the antennas are to be mounted so that installation and maintenance of the antennas and communications equipment and/or building can be accomplished.
- k) Certification that the wireless support structure will be built to manufacturer standards and specifications; and,
- l) Any other information requested by the Executive Director, the Area Plan Commission, and/or the Area Board of Zoning Appeals to allow proper evaluation of the request.

4. "Good Faith Certification" Evidence supporting the choice of location for the proposed wireless support structure, including a sworn statement from the individual responsible for the choice of location demonstrating that collocation of wireless facilities on an existing wireless support structure, utility pole or electrical transmission tower is not a viable option because collocation:

- a) Would not result in the same wireless service functionality, coverage and capacity;
- b) Is technically infeasible; or,
- c) Is an economic burden to the applicant.

5. If the proposed site is subject to Special Exception Use approval, evidence that the application complies with the criteria set forth in the Ordinance with respect to the special exception use via a certification from the Staff that such approval has been obtained from the Area Board of Zoning Appeals

C. Area Plan Commission (APC) Approval/Denial

Within ninety (90) days from the date the application is determined to be complete, the Area Plan Commission shall approve or deny the application request. Prior to making a determination, the APC shall:

1. Review the application to determine if it complies with all applicable laws and ordinances governing land use and zoning; and,
2. Evaluate all documents and testimony associated with the subject application.

After the Area Plan Commission's hearing and evaluation, the APC will make a determination of approval or denial of the request.

After determination, the Staff will provide notification to the applicant, in writing, whether the application request is approved or denied. In the case of denial, the applicant must be provided written notice of the denial; this notice must state clearly the basis for the decision and provide substantial evidence in support of the denial.

Note: Minutes of the public meeting which contain the causes of denial satisfy the notice requirements of this Subsection.

Upon request of the applicant, the Area Plan Commission shall continue the hearing in order to provide additional time for the applicant to provide any clarification needed or cure any defects in the application, supplemental documents, other applicant submissions, or hearing testimony. The Area Plan Commission determination of the request is extended for a period equal to the extension period requested by the applicant. The applicant is limited to no more than two such continuances.

3.10.2.2 General Approval Standards

Approval of a new wireless support structure and/or wireless facility also requires the following items/requirements be met:

- A. The location of the proposed wireless support structure and/or wireless facility is compatible with White County's Comprehensive Plan;
- B. The proposed wireless support structure and/or wireless facility shall not unreasonably interfere with the view from any public park, natural scenic vista, historic building or district, or major view corridor and may not be located in a FEMA designated Flood Hazard Area, zone "AE", without certification from the Floodplain Administrator that the facility/structure meets current standards for flood proofing and elevation;
- C. At a minimum, the wireless equipment compound shall be visually enclosed as required by Chapter 9, Landscape Standards (not required for wireless facilities or structures locating within a public rights-of-way or road buffer zone);
- D. The height and mass of the wireless support structure and/or wireless facilities do not exceed that which is essential for their intended use and to assure public safety;
- E. Except where required otherwise by the FAA, the proposed wireless facilities (excluding the wireless support structure) shall be painted silver or have a galvanized finish retained in order to reduce visual impact. The wireless equipment compound shall have a security fence with an access gate along the entire

perimeter of the lot, parcel or leased area where the wireless support structure and/or wireless facility are located (not required for wireless facilities or wireless structures locating within a public rights-of-way or road buffer zone);

- F. The wireless support structure and/or wireless facilities are in compliance with all other applicable local, state, or federal regulations; and,
- G. Any proposal to locate wireless facilities and/or a wireless support structure in a public right-of-way must provide the following:
- 1) A decommissioning plan approved by the entity that owns or controls the subject rights-of-way;
 - 2) An executed lease agreement with the entity that owns or controls the rights-of-way or a letter from said entity that they are not requiring such agreement;
 - 3) A construction plan approved by the entity that owns or controls the rights-of-way; such plan must contain assurances to protect any and all improvements within the rights-of-way and which provides guarantees to replace or repair any and all improvements effected by the construction/installation process; said improvements shall include, but are not limited to, utility infrastructure, road pavement, berms, shoulders, curbs and sidewalks;
 - 4) An installation plan approved by every utility with infrastructure or facilities located within two hundred (200) feet of the proposed wireless facilities or wireless support structure location;
 - 5) Proof of insurance satisfactory to the entity that owns the rights-of-way and annual proof that such policy remains in effect throughout the life of the wireless facilities or wireless structure; failure to maintain said policy shall trigger a requirement to decommission the wireless facilities and/or wireless structure as provided for during the approval process;
 - 6) Construction must be of monopole design;
 - 7) Any ground mounted cabinet is limited to forty (40) cubic feet in volume and forty-eight (48) inches in overall height;
 - 8) Each wireless support structure must have a permanent identification plaque mounted on the pole so that it can be seen and read from the road pavement but which does not exceed forty-five (45) square inches in size; said plaque shall contain the owner's name and owner's full address and phone number; and,
 - 9) All wiring and fiber shall be concealed within the support structure and all conduit, wiring and fiber exterior to the wireless structure and within the public rights-of-way shall be buried in their entirety.

3.10.2.3 General performance standards

A. Height and setback requirements

1. In all zoning districts, not including districts within a public rights-of-way or portion within a road buffer zone, the maximum height of any wireless support structure shall be three hundred (300) feet;
2. In all public rights-of-ways or road buffer zones, regardless of zoning district classification, the maximum height of any wireless support structure shall be fifty (50) feet as measured from grade or the height of any utility pole in place on July 1, 2017 and within five hundred (500) feet of the proposed location, plus 10 feet;
3. In all zoning districts, not including a public rights-of-way or portion within a road buffer zone, the base, including the foundation, of any wireless support structure shall be set back a distance equal to the height of the wireless support structure or its fall zone area, whichever is less restrictive, unless specifically allowed elsewhere in this Section (the wireless support structure fall zone area is established as set forth in the applicant's engineering "fall zone area" certification unless the permit authority provides evidence that the applicant's engineering certification is flawed);
4. In all public rights-of-ways, the location of the base, including the foundation, of any wireless support structure shall be established by the governmental body or department having jurisdiction over the public rights-of-way. In all road buffer zones, the closest point of the base, including the foundation, of any wireless support structure and/or facilities shall be set back a minimum of eight (8) feet from the edge of pavement or in line with the nearby utility poles, whichever provides the greatest distance from the road pavement. No wireless support structure is permitted in a road buffer zone which is part of a residential zoning district unless authorized by the Area Board of Zoning Appeals or provided for elsewhere in this Section.
5. In all cases, excluding those pertaining to a public rights-of-way or road buffer zone, where a subject site has one or more property lines in common with a property, or properties, assigned an A-1, A-2, I-2 or I-3 zoning district, the setback to that (those) specific property line(s) may be altered subject to the following conditions:
 - a) The setback is not reduced to less than fifty (50) feet; and,
 - b) At least one property owner of the abutting parcel with the common property line provides to the Staff an executed, notarized letter, which includes a written statement which provides the specific setback to be applied and that all property owners of that abutting parcel have agreed to the altered allowance; and,
 - c) The setback alteration is not applied to any property line which abuts a road;

6. In all cases, the components of all wireless facilities are subject to the accessory structure setback requirements of the site's zoning district assignment for accessory structures; and,
7. Unless specifically provided for elsewhere, all setbacks are measured from lot/parcel property lines or road rights-of-way lines, whichever are most restrictive (lease lines vs individual structures may be utilized for the purpose of demonstrating compliance to setback requirements).

B. Location

1. It is encouraged that antennas be placed upon existing structures, including, but not limited to, building rooftops, water towers, utility poles, electrical transmission towers or existing wireless support structures instead of building new structures.
2. A wireless support structure or wireless facilities may be located on a lot or parcel occupied by a principal structure and may occupy a leased area of said lot or parcel. In those instances, the required setback between the wireless support structure and the principal structure shall be no less than the equivalent of the height of the tower or the fall zone area, whichever is least restrictive.
3. Execution of a subdivision shall not be required to provide for a "leased parcel" on which a wireless support structure and/or a wireless facility is proposed to be constructed, provided the wireless facilities are unmanned.
4. There will be a minimum separation of one thousand (1,000) feet between any two wireless support structures as measured radially from the center of each structure.

C. Access to facility

Access shall be provided to the facilities by means of a public street or easement to a public street. The easement shall be a minimum of twenty (20) feet in width and shall be improved to a width of at least twelve (12) feet with gravel or pavement for its entire length.

D. Landscaping/Security

Except in the case of wireless facilities or wireless structures located in a public rights-of-way or road buffer zone, wireless structures and facilities shall be screened and secured in accordance with the provisions of Chapter 9, Section 9.3, Subsection 9.3.7 of Landscaping Standards.

E. Wireless support structure lighting and signs

No signs or lights shall be mounted on a wireless support structure, except as may be required by the Federal Communications Commission, Federal Aviation Administration or other governmental agency which has jurisdiction.

F. Abandonment

An abandoned or unused wireless support structure or wireless facilities or portions thereof must be decommissioned as approved by the Area Plan Commission at the time of application approval or, if no such decommissioning plan exists, as follows:

1. The applicant or subsequent owner/lessor shall remove all abandoned or idled wireless support structures and/or wireless facilities, or portion thereof, within one hundred and eighty (180) days of the cessation of their use at the site unless the Executive Director, in writing, approves a time extension;
2. Upon decommissioning and removal of all wireless support structures and wireless facilities, the site will be returned to its preconstruction condition, as near as possible, in the context of soil quality, topography and vegetation;
3. Any and all expenses from the decommissioning effort shall be borne by the applicant or their successor;
4. In the event that the abandoned or idled wireless support structure and/or wireless facilities, or portion thereof, are not removed within one hundred eighty (180) days of the cessation of their use at a site, the failure will be considered a civil zoning violation. The County reserves the right to remove the wireless support structure and/or wireless facilities, or portion thereof, at any time after cessation of operations with any and all costs of removal assessed against the operator and/or owner of the wireless structure(s) and/or wireless facilities.

3.10.3 EXISTING WIRELESS SUPPORT STRUCTURE AND/OR WIRELESS FACILITY (SUBSTANTIAL MODIFICATION)

3.10.3.1 Application and Approval Procedure – Modifications, Site Improvement Upgrades, Facilities Alteration/Upgrade & Equipment Revisions

A. Application Review

The Executive Director or Office Administrator shall approve/deny all applications for a wireless support structure or wireless facilities modification, substantial or otherwise, including, but not limited to, site improvement upgrades & equipment revisions. All applications shall be reviewed and determination for completeness made within ten (10) business days from its receipt. If the application is not complete, the Executive Director or Office Administrator shall notify the applicant in writing of all defects in the application. Unless notified in writing otherwise, an applicant has thirty (30) days from the date of application status notice to cure the defects in the application. If the applicant cannot meet the thirty (30) day deadline, they may request, in writing, up to, but no more than, (90) days to resolve any application defects.

B. Application Requirements

Unless exempted elsewhere in Section 3.10, any time a legally existing wireless support structure and/or wireless facilities is subject to modification, site improvement upgrades, facilities alteration/upgrade, upgrade and/or equipment revision, an Improvement Location Permit (ILP) is required. (Any building or structure new construction, remodel, alteration, expansion or modification is subject to the White County Indiana Building Code Ordinance as amended from time to time and will require a Building Permit.) An ILP application, along with all supporting documents affiliated with such application, including the applicable filing fee, must be submitted to the Area Plan Office for review and approval/denial. In addition, each application must include the following information:

1. The owner/operator's name, business address and point of contact for the applicant;

2. The location address and parcel # of the proposed or affected wireless support structure or wireless facility;
3. A construction plan that describes the proposed construction, modifications, upgrades, alterations or revisions to the wireless support structure and/or all equipment and network components, including antennas, transmitters, receivers, base stations, power supplies, cabling and related equipment. Such plan must include:
 - a) Engineer's report (if applicable) - A report from a qualified and licensed professional engineer which certifies that the proposed construction, installations, alterations, modifications, revisions or upgrades will not exceed the structural capacity of the wireless support structure to which equipment is intended to be mounted considering wind and other load variables associated with the site location and the construction design of the wireless support structure;
 - b) A certification from the installer or applicant that the site will be in compliance with the requirements of all Federal, State and Local laws, and all government department and agency rules and regulations to avoid interference with established public safety telecommunications; and,
 - c) A site plan which provides:
 - (1) The physical location on the property of any new wireless support structure or wireless facilities to be added as a part of the proposed scope of work;
 - (2) The overall height of the wireless support structure and, for each antenna to be added, the location from ground level of said antennas; and,
 - (3) Any other information requested by the Executive Director, Office Administrator, Area Plan Commission, and/or Area Board of Zoning Appeals in order to properly evaluate the application.

C. Executive Director Approval/Denial

Within ninety (90) days from the date the application is determined to be complete, the Executive Director or Office Administrator shall:

1. Review the application to determine if it complies with all applicable laws and ordinances governing land use and zoning; and,
2. Evaluate all documents and information associated with the subject application.

After evaluation, the Executive Director or Office Administrator will make a determination of approval or denial of the request.

After determination, the Staff will provide notification to the applicant, in writing, whether the application request is approved or denied. In any case of denial, this notice must state clearly the basis for the decision and provide substantial evidence in support of the denial.

Notwithstanding the ninety (90) day period set forth in Section 3.10.3.1 (C), an applicant can request additional time to cure defects in the application which will automatically extend the determination deadline by an amount equal to the extension granted.

3.10.4 Application and Approval Procedure – Collocations

A. Application Review

The Executive Director or Office Administrator shall approve/deny all applications for collocations. All applications shall be reviewed and determination for completeness made within ten (10) business days from its receipt. If the application is not complete, the Executive Director or Office Administrator shall notify the applicant in writing of all defects in the application. Unless notified in writing otherwise, an applicant has fifteen (15) days from the date of application status notice to cure the defects in the application. If the applicant cannot meet the fifteen (15) day deadline, they may request, in writing, additional time to cure any application defects. The fifteen (15) day deadline is extended for a period of time equal to the request of the extension.

B. Application requirements

All requests for collocations, whether applicable to a building, an existing wireless support structure and/or facilities or other structure, are required to obtain an Improvement Location Permit (ILP). An ILP application, along with all documents required by such application, including the applicable filing fee, must be submitted to the Area Plan Office for review and approval/denial. (Any building or structure construction, remodel, alteration, expansion or modification is subject to the White County Indiana Building Code Ordinance as amended from time to time and will require a Building Permit.) In addition, each application must include the following information:

1. The owner/operator's name, business address and point of contact for the applicant;
2. The location address and parcel # of the proposed collocation site; and,
3. If applicable, evidence of conformance with applicable building permit requirements.

An application for a permit for collocation:

- (1) is not required to comply with zoning or land use requirements; and
- (2) is not subject to a public hearing.

Note: Applicants are allowed to submit a single application and receive a single permit for multiple collocations at multiple sites as long as all sites are within the jurisdiction of the Area Plan Commission.

C. Executive Director/Office Administrator Approval/Denial

Within forty-five (45) days from the date the application is determined to be complete, the Executive Director or Office Administrator shall approve or deny the application request in writing. However, if the applicant requested additional time under subsection (e) to cure defects

in the application, the forty-five (45) day period is extended for a corresponding amount of time. Prior to making a determination, the Executive Director or Office Administrator shall:

1. Evaluate all documents and information associated with the subject application.

After evaluation, the Executive Director or Office Administrator will make a determination of approval or denial of the request.

After determination, the Staff will provide notification to the applicant, in writing, whether the application request is approved or denied. In any case of denial, the applicant must be provided written notice of the denial; this notice must state clearly the basis for the decision and provide substantial evidence in support of the denial.

3.10.5 Construction, Placement or Use of Small Cell Facilities

A. Prohibitions:

- 1) No new utility pole or new wireless support structure may be placed within rights-of-way within an area that is designated strictly for underground or buried utilities without approval of a variance from the Area Board of Zoning Appeals. The subject area must have been dedicated before May 1, 2017. This prohibition is subject to the requirements and standards provided for in IC 8-1-32.3-15 as amended from time to time.
- 2) Small cell facilities may not be collocated on any:
 - a) privately owned utility pole;
 - b) privately owned wireless support structure; or,
 - c) private property; without consent of the owner of the utility pole, wireless support structure or property, as applicable.

B. Application Review

Unless explicitly prohibited elsewhere in this Section, the Executive Director or Office Administrator shall approve/disapprove all applications for construction, placement or use of Small Cell Facilities. All applications shall be reviewed and determination for completeness made within ten (10) business days from its receipt. If the application is not complete, the Executive Director or Office Administrator shall notify the applicant in writing of all defects in the application. Unless notified in writing otherwise, an applicant has fifteen (15) days from the date of application status notice to cure the defects in the application. If the applicant cannot meet the fifteen (15) day deadline, they may request, in writing, additional time to cure any application defects.

C. Application Requirements

Any time small cell facilities are subject to department approval, an Improvement Location Permit (ILP) is required. An ILP application, along with all documents required by such application, including the applicable filing fee, must be submitted to the Area Plan Office for review and approval/denial. An applicant is allowed to submit a single consolidated application for multiple small cell facilities under issuance of a single permit for the small cell network; the fee charged in such case shall be based on the number of

small cell facilities covered under the application. In addition, each application must include the following information:

1. The owner/operator's name, business address and point of contact for the applicant;
2. A location map identifying the specific location of each small cell facility and/or structure subject of the permit application;

In the case where a permit includes the location of one or more new support structures, a development plan which includes the following:

- a) The overall height of each proposed wireless support structure and the location and height of surrounding structures (those within 500 feet of the proposed location) when applicable;
- b) The distance from the closest point of the wireless support structure to each parcel line or rights-of-way line, whichever is most restrictive; and,
- c) In cases of location on private property, a notarized letter of authorization from the property owner.

Exemption: The placement of a small cell facility and associated supporting structure in a public rights-of-way is exempt from zoning review if the total height of the supporting structure does not exceed the greater of fifty (50) feet as measured from grade or the height of any utility pole (plus ten (10) feet) in place on July 1, 2017 and within five hundred (500) feet of the proposed small cell facility.

In all cases where an application is for construction, placement or use of a small cell facility and a supporting structure at a location where a supporting structure does not exist, the Executive Director or Office Administrator may propose an alternative location for the proposed small cell facility or that the small cell facility be collocated on an existing utility pole or an existing wireless support structure as long as such pole or structure is located within fifty (50) feet of the proposed location. The applicant shall use the alternative location proposed by the Executive Director or Office Administrator if:

1. The applicant's right to use the alternative location is subject to reasonable terms and conditions; and,
2. The alternative location will not result in technical limitations or additional costs, as determined by the applicant

C. Executive Director/Office Administrator Approval/Denial

Within sixty (60) days from the date the application is determined to be complete or sixty (60) days plus the extended time granted to the applicant to cure application defects, the Executive Director shall approve or deny the application request. Prior to making a determination, the Executive Director or Office Administrator shall:

1. Review the application to determine if it complies with all applicable laws and ordinances governing land use and zoning; and,
2. Evaluate all documents and information associated with the subject application.

After evaluation, the Executive Director or Office Administrator will make a determination of approval or denial of the request.

The evaluation process may not do any of the following:

1. Limit the placement of a small cell facility by minimum separation distances or maximum height limitations;
2. Impose unreasonable requirements regarding the maintenance or appearance of the small cell facility and associated supporting structure, including requirements concerning the types of materials to be used or the screening or landscaping of the location;
3. Condition the approval on the applicant's agreement to allow other wireless facilities to be placed at, attached to, or located on the associated wireless support structure or utility pole;
4. Limit the duration of any permit granted subject to construction commencing not later than two (2) years after the date the permit is granted;
5. Prohibit an applicant from locating a small cell facility, wireless support structure or utility pole in a residential area;
6. Impose setback or fall-zone requirements for the associated wireless support structure or utility pole that are different from requirements imposed on other types of structures in a public right-of-way; or,
7. Require the removal of existing wireless support structures, wireless facilities, or utility poles as a condition for approval of the application; subject to the decommissioning rules of Section 3.10 of this Chapter.

Every application intended for location within a public right-of-way, is subject to reasonable and generally applicable safety regulations under IC 8-1-2-101 (b) as amended from time to time.

Any construction, placement or use of small cell facilities on a utility pole owned or controlled by a governmental unit is subject to the following:

- 1) The rate charged by the governmental unit may not exceed fifty dollars (\$50) per utility pole per year;
- 2) For a utility pole used to provide communications or electric service, all parties to the construction, placement or use shall comply with the process for make ready work under 47 U.S.C 224 and any associated implementing regulations (The good faith estimate of the unit owning or controlling the utility pole with respect to any make ready work necessary to enable the utility pole to support the requested replacement must include pole replacement if necessary);
- 3) For a utility pole that does not support aerial facilities used to provide communications service or electric service, the unit shall provide a good faith estimate for any make ready work necessary to enable the utility pole to support the requested construction, placement, or use, including pole replacement, if necessary, not later than sixty (60) days after the unit's receipt of a complete application from the Staff; all make ready work shall be

completed within sixty (60) days after the applicant's written acceptance of the good faith estimate;

- 4) The unit shall not require more make ready work than required to meet applicable codes or industry standards. Fees for make ready work may not include costs related to preexisting or prior damage or to noncompliance. Fees for make ready work, including any utility pole replacement, may not:
 - (a) Exceed actual costs or the amount charged to communications providers for similar work; or,
 - (b) Include any consultants' fees or expenses.
- 5) Subject to subdivision 7 below, the unit shall offer rates, fees and other terms for construction, placement or use that comply with this Chapter and Section. Not later than December 31, 2017 or three (3) months after receiving the first request under this chapter for the construction, placement or use of a small cell wireless facility on a utility pole owned or controlled by the unit; whichever occurs later, the unit shall make available by ordinance or otherwise, the rates, fees and terms that govern the construction, placement or use of small facilities on utility poles owned or controlled by the unit and that are in compliance with Section 3.10 of this Chapter.
- 6) The unit or a utility owned by the unit shall not impose a rental or other reoccurring fee for small cell facilities that are strung or located between utility poles if one (1) or more of the utility poles has an associated attachment for which a rental rate is charged.
- 7) The unit may impose additional general terms and conditions for the construction, placement or use of small cell facilities on utility poles owned or controlled by the unit if the additional general terms and conditions are:
 - (a) consistent with Chapter 3, Section 3.10;
 - (b) reasonable;
 - (c) nondiscriminatory; and,
 - (d) generally applicable to users of rights-of-way.

Additional general terms and conditions authorized by this subsection, must be included in the rates, fees and terms that the unit is required to establish and make available under subsection 5 above.

3.11 **EXTRACTIVE MANUFACTURING**

All potential Extractive Manufacturing operations require development plan approval by the Area Plan Commission and the appropriate legislative body prior to the commencement of site activities. Each Development Plan shall include, but is not limited to, the following:

- A Drainage Plan Letter of Approval from the White County Drainage Board,
- Setback distances from property lines for mining and crushing activities,
- Egress-Ingress location(s) and dimensional specifications,

Landscape plan,
Blasting parameters and schedule limitations,
Dust suppression plans,
Reclamation plan,
Berms/Fencing and other relevant perimeter safeguards,
Commitments & conditions offered,
Contingency plan for potential hazards,
Plan of protection of surrounding and adjacent properties,
Road use agreement, traffic plan & maintenance and repair bond,
Contact information for operating parties (notification of any changes required within five (5) working days of the effective change date),
Contact information for main office (if off-site), and
Any other reasonable requirements requested by the Area Plan Commission or Staff.

3.12 **DIGESTERS, AEROBIC OR ANAEROBIC**

Aerobic Digester:

1. Zoning District: Permitted: A-2 or I-2 Accessory Use: A-1, A-2, I-1, I-2
2. Minimum setback for all facilities where processing occurs and/or storage of any nature is as follows:
 - a. * Any Front Property Line: One hundred (100) feet
 - b. * Any Side Property Line: Two hundred (200) feet
 - c. * Any Rear Property Line: Two hundred (200) feet
 - d. * Any residential district boundary line or any other residence, excluding those located on the same property: One thousand (1,000) feet unless the owner of such residence or residential property waives such restriction in notarized form to the Area Plan Office.
 - e. * All other structures shall comply with the setback requirements as provided for in Appendix B Bulk Use Standards of the White County Indiana Zoning Ordinance.
 - f. * Lagoons must have no boundary closer than one thousand (1,000) feet to any property line.
3. Minimum Area: 10 Acre parcel which does not exceed a three to one ratio as determined by the shortest distance between the front and rear property lines and the shortest distance between the side property lines. A parcel shall not be

required to meet such standard should said parcel have been created prior to January 1, 2009.

4. * Applicant must provide any and all approval certificates from IDEM to demonstrate compliance with all IDEM requirements.
5. * No facilities or structures, principal or accessory, may be located within one mile from an incorporated municipality boundary line unless the appropriate legislative body waives this requirement via official notice to the Area Plan Department.
6. A transportation plan must be submitted prior to the issuance of an improvement location permit detailing the effect of the development on local roadways, including before and after construction traffic volume, impact on road maintenance, congestion and noise.
7. A general operational plan must be submitted which describes the processing steps, the waste streams intended to be used and their sources plus any additional pertinent information related to how the facility will operate.
8. * Site shall comply with the landscaping requirements of Table 9:1 and with the applicable sections of Chapter 8 of the White County Indiana Zoning Ordinance.
9. The applicant shall submit a decommissioning plan to the Area Plan Commission for approval. The plan must be in compliance with IDEM requirements for the removal of the digester facility and its supporting accessory structures for when it becomes functionally obsolete or is no longer in use.
- 10.* Lot coverage and any other developmental standards not listed in this section shall be established by the standards specified in the White County Indiana Zoning Ordinance.
- 11.Only those requirements designated with an “*” apply to a digester utilized as an accessory use to an on-site principal use.
- 12.No digester will be allowed within any municipality boundary unless owned and operated in conjunction with the municipality government.
- 13.A digester which falls within any municipality boundary which is owned and operated in conjunction with a municipality government is exempt from the requirements of this section.

Anaerobic Digester:

- 14.Zoning District: Permitted: A-2 or I-2 Accessory Use: A-1, A-2, I-1, I-2
- 15.Minimum setback for all facilities where processing occurs and/or storage of any nature is as follows:
 - a. * Any Front Property Line: One hundred (100) feet
 - b. * Any Side Property Line: Two hundred (200) feet
 - c. * Any Rear Property Line: Two hundred (200) feet

- d. * Any residential district boundary line or any other residence, excluding those located on the same property: Five hundred (500) feet unless the owner of such residence or residential property waives such restriction in notarized form to the Area Plan Office.
 - e. * All other structures shall comply with the setback requirements as provided for in Appendix B Bulk Use Standards of the White County Indiana Zoning Ordinance.
 - f. * Lagoons must have no boundary closer than five hundred (500) feet to any property line.
16. Minimum Area: Seven (7) Acre parcel which does not exceed a three to one ratio as determined by the shortest distance between the front and rear property lines and the shortest distance between the side property lines. A parcel shall not be required to meet such standard should said parcel have been created prior to January 1, 2009.
- 17.* Applicant must provide any and all approval certificates from IDEM to demonstrate compliance with all IDEM requirements.
- 18.* No facilities or structures, principal or accessory, may be located within one mile from an incorporated municipality boundary line unless the appropriate legislative body waives this requirement via official notice to the Area Plan Department.
19. A transportation plan must be submitted prior to the issuance of an improvement location permit detailing the effect of the development on local roadways, including before and after construction traffic volume, impact on road maintenance, congestion and noise.
20. A general operational plan must be submitted which describes the processing steps, the waste streams intended to be used and their sources plus any additional pertinent information related to how the facility will operate.
- 21.* Site shall comply with the landscaping requirements of Table 9:1 and with the applicable sections of Chapter 8 of the White County Indiana Zoning Ordinance.
22. The applicant shall submit a decommissioning plan to the Area Plan Commission for approval. The plan must be in compliance with IDEM requirements for the removal of the digester facility and its supporting accessory structures for when it becomes functionally obsolete or is no longer in use.
- 23.* Lot coverage and any other developmental standards not listed in this section shall be established by the standards specified in the White County Indiana Zoning Ordinance.
24. Only those requirements designated with an “*” apply to a digester utilized as an accessory use to an on-site principal use.
25. No digester will be allowed within any municipality boundary unless owned and operated in conjunction with the municipality government.

26. A digester which falls within any municipality boundary which is owned and operated in conjunction with a municipality government is exempt from the requirements of this section.

3.13 HOSPITAL AND MEDICAL, MENTAL HEALTH FACILITY (OR PSYCHIATRIC HOSPITAL)

Entrances and interior roads

1. Prior to issuance of an Improvement Location Permit and prior to construction of any Hospital or Medical, Mental Health Facility, the developer shall provide a letter from the appropriate municipal or county legislative body verifying the approval of the ingress-egress access design in addition to complying with all requirements of the White County Indiana Zoning Control Ordinance.

Thoroughfare plan

2. At the time of, or prior to, submission of development site plan, a detail thoroughfare plan must be submitted for review by the Staff. Such document will include, but is not limited to, a projection of increase passenger vehicle traffic, anticipated required road improvements, summary of expected delivery and operating vehicle traffic loads including emergency vehicles, potential impacts on surrounding sites and the community at large and anticipated frequency of hazardous material deliveries, including types of such materials. It will include accessibility impacts for taxis, busses and other public modes of transportation.

Heliport/Air service

3. A written notification of any air service to be utilized by the facility including the site details for handling such service.
4. Community impacts
5. Provide a written summary of impacts of the development on all types of pedestrian circulation in any area within two thousand five hundred (2,500) feet of all property boundaries. This shall include impacts on walking, non-motorized transportation, such as bicycles, and handicap accessibility.

3.14 I-3 ZONING DISTRICT

All I-3 Zoning Districts are subject to the standards of this Section. Where a conflict occurs between this section and any other requirement of the White County Indiana Zoning Control Ordinance, this section shall rule. These requirements are in addition to any and all other requirements provided for in this Ordinance.

A. Building Requirements

1. Prior to application for a Building Permit or Improvement Location Permit, each developer must provide a preliminary architectural plan which must include:
 - a. Elevations and/or renderings of the proposed building(s);
 - b. A conceptual floor plan;

- c. A rendering or artistic drawing of the proposed landscaping, parking, signage and any other exterior amenities planned for the site.
 2. The ground floor footprint for the principal building of each lot must be a minimum of thirty thousand (30,000) square feet.
- B. Accessory Building
 1. All accessory buildings, with the exception of a guard shack or similarly functioning type building, shall be located behind the rear building line of the principal structure. Guard shacks or similarly functioning type building must meet the front, side and rear setback requirements for an accessory structure as provided for in Appendix B: Bulk Use Standards.
 2. All non-building accessory structures shall be located behind the front building line of the principal structure.
 3. All accessory buildings shall be architecturally compatible with the principle building on the lot.
- C. Design Requirements
 1. Predominant building materials shall be naturalistic materials, such as brick and stone, decorative and/or painted pre-cast concrete panels or architectural metal panels.
 2. Any side of any building facing a highway or a road shall be constructed of precast concrete, tilt-up concrete, glass, brick, architectural metal panels, or combination thereof.
 3. Any portion of a front wall, façade or side wall of any building that is visible from the public right-of-way shall not be constructed of corrugated metal or aluminum siding, unpainted wood, wood shingles or exposed concrete or cinder blocks. Industrial grade, pre-engineered metal building siding may be utilized on walls not facing a public right-of-way.
 4. Roofs of one or two-story buildings shall have steep pitched roofs with hipped or gabled ends. Roof materials shall be traditional in composition and complement the architectural features of the building. Flat roofs are allowed provided that parapet walls or heavy cornices are utilized to screen all mechanical units.
 5. Windows, architectural detailing and the articulation of entrances shall be prominent and proportional with the building size and mass.
 6. Air conditioning units and/or equipment or other building affiliated structure, excluding rooftop equipment, which is visible on or near the exterior of the building shall be screened from the view of all streets/roads and adjoining properties.
 7. Any development required to orient their facilities facing US Highway 24 or Division Road must locate all truck docks and the dock area to the rear or side of such facility.

D. Site Requirements

1. Each principal building shall have a minimum height of 32', either at the roof line or the top of the parapet wall, excluding exclusive office areas.
2. All principal buildings north of the TP & WW RR Right-Of-Way shall be oriented toward US Hwy 24; all principal buildings north of and with lots or parcels adjacent to US Hwy 24 shall be oriented toward US Hwy 24; all principal buildings south of the TP & W RR shall be oriented toward Division Road.
3. All exterior lighting shall be directed internally upon each lot so as not to be directed on adjoining lots or streets/roads. Directly down or directly up parking lot lights are allowed. Lighting of exterior walls or signage must be direct lighting (wall packs discouraged).
4. Each site shall dedicate a minimum of fifteen percent (15%) of their total parcel area to greenspace (grass or vegetative ground cover).

E. Setbacks and Lot/Parcel Coverage

1. The perimeter of any parking lot or driveway area, excluding ingress/egress locations, shall be allowed within any front, side or rear setback as long as such perimeter is not closer than 10' to any property line or road right-of-way, whichever is most restrictive.
2. No building on a lot or parcel adjacent to a planned frontage road, right of way shall be closer than 175' from the centerline of US Hwy 24. In all other circumstances, no building on a lot or parcel shall be closer than 80' from the centerline of US Hwy 24.
3. No building shall be closer than 50' from the centerline of any other public right-of-way.
4. No building shall be closer than 30' from any side or rear property line.
5. Buildings footprint areas shall not exceed 70% of the lot or parcel area.
6. Accessory structures, excluding Accessory Buildings, shall be allowed within any rear or side setback but may not be any closer than 10' to any rear or side property line.

F. Miscellaneous Requirements

1. Headwalls for drainage pipes under driveway entrances shall be designed and constructed with a slope and flare.
2. All public utilities, with the exception of major electric transmission lines responsible for transporting power through the area rather than to the area shall be installed underground.
3. Every lot/parcel shall provide an individual storm water detention pond or be connected to an existing storm water detention pond. If a storm water district exists, compliance with the requirements and fees of such a district shall be required.

4. No on-site, non-public, individual storage tanks in excess of 500 gallons shall be allowed, including, but not limited to, those used for the storage of gasoline, diesel fuel, oil, water, or propane gas. This maximum volume limitation may be waived upon receipt by the Staff of a letter of approval from the Board of Commissioners of White County. All above ground tanks shall be enclosed by an opaque fence and gate and locked at all times other than for access or service. All such storage tanks shall fully comply with any and all applicable local, state and federal statutes and administrative regulations.
5. No outside storage, unless provided for elsewhere in this Section, is permissible. This requirement may be waived upon receipt by the Staff of a letter of approval for specific outside storage activities from the Board of Commissioners of White County.
6. In addition to the screening requirements of Chapter 9, Subsection 9.3.8, as amended from time to time, all refuse and recycling area screening must be architecturally compatible with the principal building.
7. Parking lots areas for employees, vendors, freight vehicles or company vehicles shall be exempt from any tree island requirement otherwise provided for in this ordinance.
8. Parking lot areas for visitors must meet the tree island requirements as provided for in this ordinance.
9. All signs are subject to the standards, restrictions and limitations provided for in Chapter 10 of this Ordinance as amended from time to time. Wall signage is subject to the following additional restrictions:
 - a. For any elevation facing a public right-of-way, the sign(s) must be incorporated into the building façade;
 - b. Wall signs cannot be painted directly onto the building elevation;
 - c. All signage, unless designated as “exempt” in Chapter 10, must be consistent in style and scale with its associated structure;
 - d. Individually illuminated channel letters are preferred; and,
 - e. Back-lit, internally illuminated box signs are not allowed.

Note: Infrastructure associated with connecting a facility’s operations to the railroad line running alongside Mid America Commerce Park properties are exempt from zoning developmental standards.

3.15 GENERAL PERFORMANCE STANDARDS

In the interests of protecting the public health, safety and welfare, and to lessen injury to property, all uses established or placed into operation after the effective date of this Ordinance shall comply with the following performance standards. No use shall exhibit obnoxious characteristics to the extent that it constitutes a public nuisance as further prescribed hereinafter. No use in existence on the effective date of this Ordinance shall be so altered or modified to conflict with these standards.

3.15.1 Authority

All uses shall comply with the performance standards established in this Chapter, unless any federal, state, county, or local ordinance, law or regulation establishes a more restrictive standard in which event the more restrictive standard shall apply.

3.15.2 Compliance

When tests by the Executive Director indicate a possible violation of these performance standards, the Executive Director shall require the property owner to obtain and bear the cost of the appropriate technical assistance to ascertain the exact amount of emissions of noxious effects at the lot lines of the property in questions. The results of the test or tests shall be presented to the Area Plan Commission in writing.

3.15.3 Enforcement

Enforcement of the performance standards shall be the duty of the Executive Director pursuant to Chapter 13, Enforcement.

3.15.4 Exceptions

The following exceptions to general performance standards, apply to:

Site preparation or construction, maintenance, repair, alteration, or improvement of buildings, structures, equipment, or other improvements on or within the lot lines.

The operation of motor vehicles or other facilities for the transportation of personnel, materials, or products;

Conditions beyond the control of the user such as fire, explosion, accident, failure, or breakdown;

Safety or emergency warning signals or alarms necessary for the protection of life, limb, or property;

3.15.5 General provisions

The following shall apply to all uses, unless otherwise provided for by this Ordinance.

Fire protection - Firefighting equipment and prevention measures acceptable to the local Fire Department shall be readily available and apparent when any activity involving the handling or storage of flammable or explosive materials is conducted.

Fire and explosion hazards - Materials that present potential fire and explosive hazards shall be transported, stored and used only in conformance with all applicable federal, state, or local ordinances and laws.

Toxic matter - The storage, handling, or transport of toxic substances shall comply with all federal, state, county and local laws and regulations regarding the storage, handling, and transport of toxic material. No use shall discharge across the boundaries of its lot toxic matter so as to endanger the public health, safety, or general welfare, or cause injury or damage to an abutting or adjoining property.

Electrical disturbance - No use shall cause electrical disturbance adversely affecting radio, television, or other equipment in the vicinity.

County Nuisance and Odor Ordinances; Indiana Nuisance Code – All uses, activities and developments shall be in compliance with the standards, limitations, restrictions and requirements of any County Nuisance and/or Odor Ordinance and are also subject to the Indiana State Nuisance Code, IC 32-30-6, as amended from time to time. In addition, all land uses, activities and developments are subject, but not limited to, the standards, regulations and requirements of Subsections A-F below. In any case where there is conflict between A-F below and the aforementioned Ordinances and/or Indiana State Code, the Ordinances and/or Indiana State Code shall rule.

- A. Poisonous and injurious fumes and gases - The emission of any gas or fumes across lot lines in such concentrations as to be detrimental to or endanger public health, safety, comfort, and welfare or which shall cause injury or damage to property or business is prohibited. The emission of toxic and/or injurious fumes and gases, from any source, shall not exceed ten (10) percent of the threshold limits set forth in the latest book of guidelines published by the American Conference of Governmental Industrial Hygienists (ACGIH) pertaining to Threshold Limit Values (TLV's) and Biological Exposure Indices (BEI's) for the workplace.
- B. Air pollution - No use shall discharge across the lot lines fly ash, dust, smoke, vapors, noxious, toxic or corrosive matter, or other air pollutants in such concentration as to be detrimental to health, animals, vegetation or property, or in conflict with public air quality standards established by State or Federal agencies.
- C. Smoke - The maximum amount of smoke emissions permitted shall be determined by the use of the Standard Ringleman Chart issued by the United States Bureau of Mines. No smoke darker than No. 2 shall be allowed.
- D. Heat and glare - No use shall produce heat or glare in such a manner as to create a hazard perceptible from any point beyond the lot lines.
- E. Water pollution - No use shall produce erosion or other pollutants in such quantity as to be detrimental to adjacent properties or in conflict with public water quality standards.
- F. Waste matter - No use shall accumulate within the lot or discharge beyond the lot lines any waste matter, whether liquid or solid, in conflict with applicable public health, safety and welfare standards and regulations.

3.16 SPECIAL EXCEPTION USE CRITERIA & REQUIREMENTS

The following standards and regulations are required criteria when a Special Exception Use Permit is required. These standards are to be applied by the Staff in cases where the use is a "permitted" use as provided for in Appendix A: Official Schedule of Uses.

3.16.1 Category 1: Adult Entertainment Business; Tattoo Parlor

A Category 1 use cannot be within five hundred (500) feet of any church, public, private or parochial school, library, public park, county courthouse, municipal building, licensed child care facility, museum, public swimming area or any residential zoning district as measured from the closest property line of the use to the nearest property line of the use described within this requirement.

All distances shall be measured in a straight line without regard to intervening structures or objects from the closest property line to each such use or application.

The minimum distance between any Category 1 use property line and another Category 1 use property line shall be one thousand (1,000) feet.

Should any Category 1 use be located in a multiple entity development, the exterior walls shall substitute for the property lines for that particular Category 1 business.

No Category 1 use shall be conducted in any manner that permits the observation of any material depicting, describing or relating matters or performances as defined by IC 35-49-2, as amended from time to time, by display, decorations, sign, show, window or other opening observable from any neighboring property or public right-of-way.

Each Category 1 use must meet all other ordinance requirements as provided for in the White County Indiana Zoning Ordinance and any other requirement designated by the Board of Zoning Appeals.

3.16.2 Category 2: Agricultural Industry; Agricultural Research Firm; Asphalt Plant (manufacturing); Bottled Gas Storage & Distribution Yard; Construction, Heavy Contractors; Ethanol or other similar Bio-Processing Plant; Explosives, Use or Storage; Hatchery, Commercial; Hazardous Waste Landfill/Facility; Incinerator; Industrial Waste Facility; Junkyard; Landfill; Recycling Facility; Scrap Metal Yard; Sewage Treatment Plant, Private; Slaughter House

Each Category 2 use must be located on a parcel of land at least three (3) acres in size with no more than a 3:1 ratio in parcel length to width or parcel width to length.

For a Junk Yard, Recycling Facility, Scrap Metal Yard or Solid Waste Transfer Facility use, operations shall be conducted entirely within enclosed buildings or an area bordered by opaque fence not less than 8 feet in height which bears no advertising and is constructed in such a manner that no outside storage or salvage operations shall be visible from an adjacent property or highway. The front yard fence requirement may be waived by the Area Board of Zoning Appeals should they deem the requirement unnecessary to preserve safety or aesthetic compatibility with any surrounding properties within one-quarter ($\frac{1}{4}$) mile from the nearest point of the front lot line measured in a straight line without regard to intervening structures or objects.

No processing operations (operations or activities performed in the making or treatment of a product) shall be conducted within three hundred (300) feet of any residential district.

There shall be a minimum of twenty (20) feet natural buffer between any property line and the fence location.

All distances shall be measured in a straight line without regard to intervening structures or objects from the closest property line to each such use or application.

Any signs or lighting permitted in conjunction with the use shall be appropriate to the location and in harmony with the general character of the properties in the area.

Special consideration shall be given to the size, design, location of these uses in relation to surrounding properties and reasonable assurances shall be provided that the use of these areas will not create noise, glare or other adverse effect on adjoining and nearby (within one (1) mile) properties.

The streets and roads serving the use shall handle any expected traffic and load increase with no more than minor traffic disruptions to adjoining or nearby (within one (1) mile) properties and no significant additional wear and tear on roadways.

Each Category 2 use must meet all other ordinance requirements as provided for in the White County Indiana Zoning Ordinance and any other requirement designated by the Board of Zoning Appeals.

3.16.3 **Category 3-A: Airport; Correctional/Penal Facility/Prison; Railroad Facilities**

Each Category 3-A use must be located on a parcel of land with no more than a three to one (3:1) ratio in parcel length to width or parcel width to length.

Minimum parcel sizes for each use will be as follows:

1. Airport – 20 Acres
2. Correctional/Penal Facility/Prison – 20 Acres
3. Railroad Facilities – As specified by Bulk Use Chart for applicable zoning district

All zoning district boundaries for any Category 3-A use must lay a minimum of one (1) mile or a distance established by the appropriate legislative body from any zoning district boundary in which any school, library, community center or religious institution sits. If a distance is applied which has been established by the appropriate legislative body, a resolution from that body must be provided to the Staff at the time of application for the special exception use permit.

Any proposed airport or airport expansion must be situated in such a manner as to not create any FAA airport regulation or zoning non-conformances.

Any Category 3-A use must submit site plans, permit applications, certifications and any other documents required to demonstrate compliance with all Federal, State and Local laws, statutes or regulations.

Each Category 3-A site must comply with any and all Federal, State and Local laws, statutes or regulations.

Any Category 3-A proposed district boundary line for a Category 3-A use, if located within one (1) mile of any municipality line, must obtain a resolution of approval authorized by the municipal legislative body prior and which must be submitted to the staff as part of their application for a Special Exception Use Permit.

Any signs or lighting permitted in conjunction with the use shall be appropriate to the location and in harmony with the general character of the properties in the area.

Special consideration shall be given to the size, design, location of these uses in relation to surrounding properties. The applicant shall provide documents certified by a qualified, registered, professional engineer that the intended use of these areas will not create noise, glare or other adverse effects on adjoining and nearby (within one (1) mile) properties.

The streets and roads serving the use shall handle any expected traffic and load increase with no more than minor traffic disruptions to adjoining or nearby (within one (1) mile) properties and no significant additional wear and tear on roadways.

All distances shall be measured in a straight line without regard to intervening structures or objects from the closest property line to each such use or application.

Each Category 3-A use must meet all other ordinance requirements as provided for in the White County Indiana Zoning Ordinance and any other requirement designated by the Board of Zoning Appeals.

3.16.4 Category 3-B: Heliport

All zoning district boundaries for any Category 3-B use must lie a minimum of one (1) mile from any zoning district boundary in which any school, library, community center or religious institution sits.

Each Category 3-B site must comply with any and all Federal, State or Local laws, statutes or regulations.

All distances shall be measured in a straight line without regard to intervening structures or objects from the closest property line to each such use or application.

Each Category 3-B business must meet all other ordinance requirements as provided for in the White County Indiana Zoning Ordinance and any other requirement designated by the Board of Zoning Appeals.

3.16.5 Category 4: Bed & Breakfast Establishment; Boarding House/Rooming House

The owner and operator of any Category 4 business shall live on the property.

No Category 4 business shall have no more than six (6) guest rooms and no more than twelve (12) occupants, beside the owner(s) and operator(s), staying at the establishment at any given time.

Any alterations made to the external appearance of any on-site structure shall not deviate from that of a residential nature.

All Category 4 establishments shall be limited to one non-illuminated, on-premise sign, no greater than eight (8) square feet.

Each Category 4 business must meet all other ordinance requirements as provided for in the White County Indiana Zoning Ordinance or any other requirement designated by the Board of Zoning Appeals.

Any Category 4 business abutting any differing zoning district must supply buffering along the perimeter of the rear and side property lines in the form of a fence compliant with Section 9.5 and minimum of five (5) feet tall or by sight obscuring vegetation.

No Category 4 business may be located within two hundred (200) feet of another Category 4 business measured in a direct line, closest property line to closest property line, without regard to intervening structures or objects.

Each Category 4 business use must provide a minimum one (1) parking space for each guest room plus two (2) for employees & owners if parking space requirements are not specified in the Parking Space Table 8.6 of the White County Indiana Zoning Ordinance.

Any signs or lighting permitted in conjunction with the use shall be appropriate to the location and in harmony with the general character of the properties in the area.

Special consideration shall be given to the size, design, location of these uses in relation to surrounding properties and reasonable assurances shall be provided that the use of these areas will not create noise, glare or other adverse effect on adjoining and nearby (within one (1) mile) properties.

The streets and roads serving the use shall handle any expected traffic and load increase with no more than minor traffic disruptions to adjoining or nearby (within one (1) mile) properties and no significant additional wear and tear on roadways.

All distances shall be measured in a straight line without regard to intervening structures or objects from the closest property line to each such use or application.

Each Category 4 business must meet all other ordinance requirements as provided for in the White County Indiana Zoning Ordinance and any other requirement designated by the Board of Zoning Appeals.

3.16.6 Category 5: Restaurant Drive-Thru; Retail Establishment (0-99,000 GSF)

Any Category 5 establishment which incorporates an outdoor shooting range may only be open to the public during the hours of 8:00 am to 8:00 pm.

Any part of a lot used for a Category 5 use, even if only on an occasional basis, must be a minimum of four hundred (400) feet from any dwelling structure, measured in a direct line from the nearest point of the Category 5 use to the nearest point of the dwelling structure.

Any Category 5 use which includes an accessory use of an outdoor shooting range must be one thousand two hundred fifty (1,250) feet from any dwelling structure, excluding any dwelling structure on the same lot, measured in a direct line from the nearest point of the Category 5 use to the nearest point of the dwelling structure.

Any signs or lighting permitted in conjunction with the use shall be appropriate to the location and in harmony with the general character of the properties in the area.

Special consideration shall be given to the size, design, location of these uses in relation to surrounding properties and reasonable assurances shall be provided that the use of these areas will not create noise, glare or other adverse effect on adjoining and nearby (within one (1) mile) properties.

The streets and roads serving the use shall handle any expected traffic and load increase with no more than minor traffic disruptions to adjoining or nearby (within one (1) mile) properties and no significant additional wear and tear on roadways.

All distances shall be measured in a straight line without regard to intervening structures or objects from the closest property line to each such use or application.

Each Category 5 business must meet all other ordinance requirements as provided for in the White County Indiana Zoning Ordinance and any other requirement designated by the Board of Zoning Appeals.

3.16.7 Category 6: Auction Arena or Sales Barn (For Livestock); Driving Range; Golf Course; Neighborhood Facility; Recreational Facility, Indoor; Recreational Facility, Outdoor, Commercial; Shooting Range Indoor; Shooting Range, Outdoor; Stable or Boarding, Commercial; Stadium, Coliseum, Athletic Field - Commercial; Theater, Outdoor

Any signs or lighting permitted in conjunction with the use shall be appropriate to the location and in harmony with the general character of the properties in the area.

Any Shooting Range operation shall be required to submit a design plan which meets the criteria for the range type proposed as provided in the NRA Range Resource Book and submit such plan as part of their Special Exception Use Permit application.

Any Shooting Range operation shall provide a safety plan as part of their Special Exception Use Permit application. This plan shall address, but not be limited to, the areas of Gun Handling Rules, General Range Rules, Specific Range Rules and Administrative Rules and Regulations using the Area Plan Shooting Range Safety handout as a guide to establishing a proper plan.

Special consideration shall be given to the size, design, location of these uses in relation to surrounding properties and reasonable assurances shall be provided that the use of these areas will not create noise, glare or other adverse effect on adjoining and nearby (within one (1) mile) properties.

In the case of a Neighborhood Facility, a resolution of support for the facility and the location must be obtained from the appropriate legislative body.

The streets and roads serving the use shall handle any expected traffic and load increase with no more than minor traffic disruptions to adjoining or nearby (within one (1) mile) properties and no significant additional wear and tear on roadways.

All distances shall be measured in a straight line without regard to intervening structures or objects from the closest property line to each such use or application.

Each Category 6 use must meet all other ordinance requirements as provided for in the White County Indiana Zoning Ordinance and any other requirement designated by the Board of Zoning Appeals.

3.16.8 Category 7: Boat Storage (Commercial); Bus Garage; Bus Station, Passenger; Truck Freight Terminal; Truck Stop; Truck Wash; Veterinary Clinic

Each Category 7 business must be located on a single parcel a minimum of two (2) Acres in size with at least two hundred (200) feet of road frontage.

There shall be no outside storage of disabled vehicles, boats or trailers, vehicles pending maintenance (unless staged in a specific area approved by the Area Board of Zoning Appeals) or merchandise such as, skids, tires, lubricants, parts, inventory

or any other items deemed more appropriately stored indoors as determined by the Staff.

Any signs or lighting permitted in conjunction with the use shall be appropriate to the location and in harmony with the general character of the properties in the area.

Special consideration shall be given to the size, design, location of these uses in relation to surrounding properties and reasonable assurances shall be provided that the use of these areas will not create noise, glare or other adverse effect on adjoining and nearby (within one (1) mile) properties.

The streets and roads serving the use shall handle any expected traffic and load increase with no more than minor traffic disruptions to adjoining or nearby (within one (1) mile) properties and no significant additional wear and tear on roadways.

All distances shall be measured in a straight line without regard to intervening structures or objects from the closest property line to each such use or application.

Each Category 7 use must meet all other ordinance requirements as provided for in the White County Indiana Zoning Ordinance and any other requirement designated by the Board of Zoning Appeals.

3.16.9 **Category 8: Vacation Home (aka: Vacation Rental, Holiday Home, Holiday Apartment, Tourist Home (VRBO))/Cabins**

Parking must comply with Chapter 8 of the White County Indiana Zoning Ordinance.

Vacation Home Rules and Regulations must be submitted to and approved by the Staff. Rules and regulations must meet the minimum requirements listed below and any other requirements established by the Staff.

1. All posted versions of Rules and Regulations must be in upper case, print lettering in legible form
2. All letters must be a minimum of one-quarter (1/4) inch tall
3. Rules and Regulations must be posted inside near (within three (3) feet) each ingress-egress door and on the outside near (within three (3) feet) main entrance door
4. Rules and Regulations shall provide for ensuring the safety of guests and neighbors and for preservation of neighborhood values. Rules and Regulations shall include, as a minimum, the following:
 - a. Phone contact numbers for police, fire, all utilities and maintenance contact plus a 24-hour contact number for property owner or manager
 - b. Maximum occupancy
 - c. Noise restrictions
 - d. Waste management
 - e. Lake safety
 - f. Trespassing

- g. Fishing
 - h. Outdoor fires or cooking
 - i. Yard Usage
 - j. Other, as required by Staff
5. Rules and Regulations shall include a diagram which makes determination of the property boundary lines easily identifiable and which includes delineation of the parking area including parking space layout

No Vacation Home principal or accessory building may be located within fifty (50) feet of any abutting residential district property line. However, any abutting neighbor may waive this requirement. Such waiver must be included as part of the applicant's application for Special Exception Use to the Area Board of Zoning Appeals. In such cases where a waiver is granted, setback requirements must be met consistent with those normally applied to the property requesting the Special Exception Use or a variance received from the Area Board of Zoning Appeals.

Maximum occupancy: Two (2) people per bedroom or sleeping room (a room where sleeping accommodations are made available) but at no time more than twelve (12) overnight guests

A smoke detector is required for each bedroom, for each room in which sleeping accommodations are available, for each kitchen and for each room in which an operating fireplace exists

A properly maintained fire extinguisher in a living or family room plus one (1) properly maintained fire extinguisher in the kitchen area or within ten (10) feet of the kitchen area perimeter

All solid waste and refuse shall be placed in appropriate refuse containers without any type of spillage outside said containers.

All solid waste containers shall prevent any unreasonable, noxious odors from escaping (unreasonable, noxious odor is an odor which can be detected from any neighboring property (one next to or across a street or alley) from the Vacation Home property

Prior to commencing Vacation Home rental use, the property owner or manager must provide to the Staff an approval certification from the sewage and water authority servicing the property. In cases where a septic serves as the sewer service, an approval from the County Health Department is required. In cases of a shared well, all property owners having rights to the well must provide a letter to the Staff expressing agreement that the well may be used to support a vacation home operation.

3.16.10 Category 9: Event Barns

These following standards and regulations must be met for Special Exception Use approval and are to be applied by the Staff in any case where an Event Barn is a permitted use by right:

- 1) Minimum parcel size: 5 acres;

- 2) Minimum road frontage: 500 feet; for a parcel with more than one road front, 500' of frontage is required for each abutting roadway;
- 3) The facility must provide a minimum driveway width of 24', maximum of 30', at the rights-of-way line.
- 4) Driveways must be located a minimum of 100' from any road intersection or driveway located on an abutting property.
- 5) The driveway construction from the rights-of-way line to the paved parking area must also be paved as required by Chapter 8: Parking and Loading of the White County Indiana Zoning Control Ordinance.
- 6) The facility must have either,
 - a) a valid septic permit for commercial activities from the White County Health Department or Indiana State Department of Health, whichever is applicable or
 - b) authorization to use portable toilet units in a quantity and under terms satisfactory to the White County Health Department.

There must be a public posting of emergency contact information in a manner approved by the Executive Director.

3.17 CFO AND CAFO ADDITIONAL DEVELOPMENTAL AND USE STANDARDS FOR ALL A-1 & I-2 DISTRICTS

IN THE INTERESTS OF PROVIDING THE APPROPRIATE PHYSICAL SEPARATION BETWEEN CFO/CAFO OPERATIONS AND RESIDENTIAL USES AND NON-RESIDENTIAL DISTRICTS WHILE ACCOMMODATING THE FUTURE NEEDS OF THESE ACTIVITIES, ALL CFO/CAFO USES PREVIOUSLY ESTABLISHED OR PLACED INTO OPERATION AFTER THIS DATE. THIS SECTION BECOMES EFFECTIVE AND SHALL COMPLY WITH THE ADDITIONAL STANDARDS PROVIDED FOR IN THIS SECTION. THESE STANDARDS ARE IN ADDITION TO ANY OTHER STANDARDS PROVIDED FOR IN THIS ORDINANCE.

- 3.17.1 Setbacks: For the purpose of satisfying setback requirements established by this Section, any building or structure used in conjunction with an existing Digester or CFO/CAFO in an A-1 or I-2 District, shall be allowed to expand or reconstruct facilities and/or operations as long as such expansion or reconstruction occurs no closer to setback points than those physically in place as of July 1, 2016 or as provided below, whichever are least restrictive.**

The setback requirements established by this Section shall not be applied to any new residential construction or rezoning occurring after July 1, 2016, excluding reconstruction on a site with existing residential use.

- 3.17.2 **A. The District cannot be located within one (1) mile of an incorporated municipality or the unincorporated town areas of Idaville and Buffalo, utilizing such boundary lines as provided for on the White County Official Zoning Map;**
- B. The District cannot be located within one and one-half (1 ½) miles from any Lake Shafer, Big Monon, Tippecanoe River or Lake Freeman shoreline boundary as provided for on the White County Official Zoning Map;**
- C. The District cannot be located within one thousand seven hundred sixty (1,760) feet from the property line of any parcel of land legally platted within a recorded subdivision and which subdivision has at least six (6) lots developed with residential dwelling units.**
- D. Those structures used in confined feeding operations, auction yards and digester operations shall have a setback of one thousand three hundred twenty (1,320) feet from any other non-agricultural district, residence or business, unless located on the same property.**
- 3.17.3 **IDEM: Confined Feeding Operations shall have Indiana Department of Environmental Management (IDEM) approval prior to issuance of an Improvement Location Permit or Building Permit. All major drainage system and water wells shall be in compliance with IDEM standards.**

3.18 **3.18 ODOR CONTROL SYSTEMS AND STANDARDS**

3.18.1 **Persons Responsible/Liable, Authority, Scope and Exclusions & Exemptions**

A. Purpose

This section is established in order to protect the public health, safety and general welfare of the community by requiring proactive steps be taken to manage odor and its potential ill effects. This section works to avoid the adverse environmental conditions created by the dispersion of non-desirable odors on the community from specific, high risk industries and business sectors.

B. Persons Liable

The property owner, operator and developer of the site have the duty of compliance with the requirements of this Section and any other requirements provided for in this Ordinance pertaining to Odor requirements and standards.

C. Authority

The Executive Director is hereby vested with the authority to review and approve or deny Odor Control Plans (OCP) when required. An initial OCP is required prior to approval of a Building Permit or Improvement Location Permit for any industry or sector included under Subsection 3.18.1 D "Scope" of this Chapter.

Where a conflict occurs between this Section and any other requirements of the White County Indiana Zoning Control Ordinance, this Section shall rule.

D. Scope

Effective January 1, 2019, all entities desiring to initiate or expand facilities or operations within the following industries or sectors are required to submit an OCP for consideration at the time of application for either an Improvement Location Permit (ILP) and/or Building Permit (BP). No ILP and/or BP shall be issued until such time as the Executive Director has approved an OCP associated with any ILP and/or BP application.

Industries or Sectors for which an approved OCP is required are as follows:

- 1) Animal Food Manufacturing (Sector)
- 2) Rendering Plant (Industry)
- 3) Asphalt Plant (Industry)
- 4) Ethanol Plant (Industry)
- 5) Bio-Processing Plant (Sector)
- 6) Slaughter House (Industry)
- 7) Agri Bio-Production (Industry/Sector)

3.18.2 OCP Submission Requirements

For purposes of this section, the term "Submission" refers to a completed Odor Control Plan which satisfies the OCP Master Guide available from the Staff. The OCP Master Guide establishes the minimum content of any Submission. The Submission shall also include any and all other documents or materials to be considered for achieving the objectives and requirements of odor management and control that are spelled out in this Ordinance. Any party required to submit an OCP must also supply any documents, information and/or certifications required by the Executive Director which, in the Director's opinion, are relevant to the OCP or Odor Management of the subject facility(ies).

3.18.3 Fees

For a submission to be considered complete and prior to review by the Staff, the OCP application fee provided for in the Official Fee Schedule must be paid to the White County Indiana Building and Planning Department.

3.18.4 Plan Compliance

Once approved, an OCP is considered compliant until such time as the complaint threshold spelled out in Subsection 3.18.5 is reached or at such time the controls, requirements, standards and processes called out in the OCP are violated.

3.18.5 Violations

Each Complaint Threshold reached and each control, requirement, standard or process of the OCP which the facility fails to properly maintain is considered a separate and unique civil zoning violation subject to the enforcement activities provided for in Chapter 13 Enforcement of this Ordinance.

3.18.6 Complaints

All complaints filed via mail, phone, in person or by electronic means shall be logged and tracked by the facility for monitoring purposes. All complaints shall be counted toward the Complaint Threshold tabulation excluding those where the party filing the complaint resides or operates more than two (2) miles away, as measured by closest property boundary of the complaining site to the closest boundary of the subject site or where said party does not provide their name, address and time & duration of the odor occurrence.

3.18.7 Complaint Threshold

The Complaint Threshold established for any entity subject to the requirement of an OCP is ten (10) independent complaints from at least five (5) different owners or tenants from different properties within any ninety (90) day rolling period.

Upon reaching the complaint threshold, the subject site shall be considered non-conforming and in violation of the White County Indiana Zoning Control Ordinance and will be subject to enforcement actions as provided for in Chapter 13: Enforcement. A report of non-conforming status shall cause the entity responsible for the non-conformance, along with the property owner(s), (if different) to immediately arrange for site testing by a qualified, independent third party, shall provide a formal, written review of the OCP with specific recommendations of changes proposed for the OCP to eliminate further threshold violations and a summary of facility odor complaints received by facility personnel for the twelve month period prior to the date the non-conforming notification issued by the Executive Director and the mitigation steps taken to address each complaint.

Site test results shall be supplied to the Area Plan Staff within ninety (90) days from the date of non-conforming notification along with the written review and summary required above.

Within thirty (30) days from receipt of the above information, the Staff will provide a written determination indicating approval, denial or conditional approval of the corrective actions taken or to be taken by the violator.

3.18.8 Responsibility – Each entity responsible for compliance to an OCP, is also responsible for the arrangements & costs related to ongoing monitoring of their odor management program as well as the arrangements and costs pertaining to a notice of violation from the Area Plan Commission Executive Director.

3.18.9 Standards – Odor measurement standards are based on a measurement of odor intensity at each property boundary line. All odor measuring shall be conducted by an inspector or firm qualified to conduct such testing. Utilization of a Field Olfactometer shall be the measuring device used to conduct the field testing. A Dilution to Threshold maximum level of 7 is hereby established as the required odor standard applicable to any entity required to submit an OCP. Alternative measuring devices and standards may only be utilized upon approval from the Area Board of Zoning Appeals.

3.18.10 Certification of Compliance - Each entity subject to an OCP must provide a Certification of Compliance within sixty (60) days from the date of issuance of the

Certificate of Occupancy (C/O). The Certification of Compliance will include, at a minimum, testing results for odor intensity levels at each property line. Should the entity require more than sixty (60) days to execute testing and to certify results, the entity shall advise, in writing to the Area Plan Executive Director, the number of additional days required to complete and certify this process. The extension period shall not exceed ninety (90) days without approval from the Area Board of Zoning Appeals. The subject entity shall bear all costs associated with testing and execution of a Certificate of Compliance.

3.18.11 Confirmation of Compliance Certificate – A Confirmation of Compliance Certificate shall be provided no later than two (2) years from the date of the original Certification of Compliance. This Confirmation of Compliance Certificate will reflect that the site and facility are in compliance with the OCP, as amended from time to time, in every respect and that the original Certification of Compliance results are still being met or exceeded. An additional Confirmation of Compliance Certificate shall be provided within every three (3) year period using the date of the most recent Confirmation of Compliance Certificate as the timeline trigger each Certificate requirement. This timeline may be waived or modified upon approval by the Area Board of Zoning Appeals. The subject entity shall bear all costs associated with testing and execution of a Confirmation of Compliance Certificate.

3.18.12 Existing Sites – Any facility or operation in a covered industry or sector as specifically provided for in Subsection 3.18.1 D of this Ordinance, and which was actively operating as of July 1, 2019 is exempted from the standards, requirements and regulations of Section 3.18 unless the operations of the facility are either abandoned or discontinued for a period of 365 consecutive days or more. In the case of a facility which does abandon or discontinue operational activity for the 365-day time period described above, Section 3.18 of this Ordinance must be met prior to re-establishing operational activity. Any expansion of an “existing site” which occurred after July 1, 2019 and which expansion area exceeds ten thousand (10,000) square feet will be required to submit an OCP and to demonstrate compliance to the threshold standard listed in Subsection 3.18.9 along with all other pertinent Subsections of Section 3.18 for the said expansion portion only. The qualified inspector or firm hired to conduct testing for the expansion should use industry “best practices” for establishing the odor allowance for the portion of operation which qualifies as an “existing site”.

Each plan shall be submitted to the Area Plan Staff for review and determination of acceptance. The Staff may approve, deny or approve with conditions any OCP submitted to it for review. In the case of denial, the Staff will provide the reasons for rejection to the submitted organization in writing within thirty (30) days after submission of a complete OCP. Any decision of the Staff may be appealed to the Area Board of Zoning Appeals by following the Appeal procedure of an administrative decision as provided for in this Ordinance.

Section 3.19: Broadband Project Application Procedure

The following procedure provides the process which an entity shall follow in order to obtain a Broadband Project Permit in White County. For purposes of this procedure and application process, a Broadband Project is defined as “The construction or deployment of wireless or wireless communications facilities to provide communications services as defined in IC 8-1-32.5-3, as amended from time to time”.

All definitions delineated in IC 5-28-28.5-8, as amended from time to time, are hereby incorporated into this procedure by reference and specific to this Section.

This procedure is applicable to both the incorporated and unincorporated areas of White County.

3.19-1: Submit a Broadband Application to the Area Plan Department (APD) for review.

3.19-2: The Application, including any required supporting documents, may be submitted in hard copy directly to the APD or submitted in electronic form under the APD’s application link on White County’s Official Web Page.

3.19-3: All applications shall be submitted on an Improvement Location Permit (ILP) application form. Any required supplemental documents shall be submitted in a form required by the ADP; although, any required supplemental document must have the ability to be submitted electronically.

3.19-4: The Department will review and approve or reject the application within 10 days from the date a properly executed application and any required supplemental documents are submitted to the APD. The APD will issue a written notification of application determination and, if rejected, the reasons for rejection.

3.19-5: The APD will issue a permit noting on the permit any required inspections.

3.19-6: The applicant or his/her representative must call-in to the APD to schedule each inspection.

3.19-7: Any required inspections will be conducted by an official of the ADP or by a representative assigned by the ADP and will be completed in a timely and expeditious manner after notification to the APD in the manner prescribed in Section 7.22-6.

3.19-8: This procedure shall not:

- A. Require an applicant to designate a final contractor to complete the project;
- B. Impose a fee to review an application or issue or Broadband Project fee;
- C. Impose a seasonal moratorium on the issuance of permits for a project; or,
- D. Discriminate among communications service providers or utilities with respect to any action described in this procedure or otherwise related to a Broadband Project, including granting access to public rights-of-way, infrastructure and poles, river and bridge crossings and any other physical assets owned or controlled by the County

CHAPTER 4 USE CLASSIFICATIONS AND PROVISIONS

4.0 PURPOSE AND INTENT

The purpose of this Chapter is to protect the health, safety and welfare of individuals as well as property values. Additionally, the standards in this Chapter are designed to preserve scarce natural resources, agricultural and sensitive environmental areas while providing for separate locations within the County for residential development and businesses and employment areas associated with economic development. In some cases, it is important to maintain and promote the separation of uses to limit incompatibility and negative impacts between uses. This Chapter is intended to establish the rules for the regulation of permitted, special exception, accessory, and temporary uses in each zoning district.

4.1 APPLICABILITY

The standards in this Chapter shall apply to each zoning district as specified.

4.2 EXPLANATION OF USE CLASSIFICATIONS

4.2.1 Official Schedule of Uses

Principal and accessory uses are permitted or prohibited in the zoning districts established by or under this Chapter, and as shown in Appendix A, Schedule of Uses. Appendix A shall determine whether or not a specific use is permitted, prohibited, or requires a special exception use in each of the zoning districts established by this Ordinance.

4.2.2 Permitted uses

A principal use may be authorized as either a permitted use or a special exception use. Permitted uses are those uses which are allowed without special permission from the Board of Zoning Appeals, provided that they comply with the provisions set forth in this Ordinance. Special exception uses are only permitted following a public hearing and approval by the Board of Zoning Appeals, as prescribed in Chapter 12, Administration, of this Ordinance.

4.2.3 Special exception uses

A special exception use is one which is generally compatible with other activities permitted within a given zoning district so long as the number, size, location and relationship to the surrounding area and site conditions are controlled. Therefore, the determination of special exception uses as appropriate shall be contingent on their meeting the standards prescribed by this Ordinance, the provisions of their respective zoning districts, and the weighing, in each case, of the public benefit and need against the local impact. All special exception uses for a parcel governed by this Ordinance shall hereby require an added level of review and approval (Refer to the special exception use permit review and approval process prescribed by Chapter 12,

Administration) to ensure compatibility with the residential, non-residential, and/or agricultural uses allowed in a given district.

4.2.4 **Accessory uses and structures**

Refer to Section 4.3 below for Accessory Use qualification and clarifications and Chapter 14 for the Accessory Structure definition.

4.2.5 **Temporary uses and structures**

Refer to Section 4.40 below.

4.2.6 **Non-conforming uses, structures, and uses and structures in combination**

Refer to Section 4.50 below.

4.3 **ACCESSORY USE PROVISIONS**

4.3.1 **General provisions**

Accessory uses shall be permitted in all zoning districts in accordance with the provisions of this Section and as provided elsewhere in this Ordinance. Accessory uses are intended to be:

- A. Incidental and subordinate to, and commonly associated with the operation of the principal use of the lot;
- B. Operated and maintained under the same ownership and on the same lot as the principal use;
- C. On a secondary lot owned by the same entity and within three hundred sixty (360) feet of the lot with the principal use; or,
- D. Located on a lot which, by deed or covenant, is designated for accessory use and structures only.

4.3.2 **Domesticated animals**

No more than five (5) domestic animals are permitted on any lot, provided that the keeping of said animals is not for profit and not construed as a kennel. Six (6) or more domestic animals shall be considered "Raising or Breeding of Non-Farm Fowl and Animals" and shall be subject to the regulations of such a use.

4.3.3 **Exotic animals**

There shall be no exotic animals permitted in any residential district unless the animal is small enough to be housed, at all times, in the primary residential structure.

4.3.4 **Livestock animals & Bees**

Livestock animals shall only be allowed within a "RR", "A-1" or "A-2 district except as provided for in this Subsection or as specifically allowed elsewhere in this Ordinance.

A. Bees

Under certain circumstances, any property owner is allowed to conduct beekeeping operations under the rules, regulations and requirements provided below: All such operations must comply with standards established by the Apiary Inspectors of America. Any conflicts between the standards listed below and those established by the Apiary Inspectors of America, the Apiary Inspectors of America standards shall prevail.

1. Exemption: Any naturally created beehive is exempt from the rules, regulations and requirements of this Ordinance Section (4.3.4). Any beekeeping operations located in an A-1 or A-2 zoning district in conjunction with an agricultural operation, whether operated as a principal or accessory use, is exempt from the rules, regulations and requirements of this Ordinance Subsection (4.3.4).
2. All beekeeping operations are subject to standards adopted by the Apiary Inspectors of America.
3. Bee, Domestic Honey: (For the purpose of this section, the term “bee” only refers to the Domestic Honey Bee as defined in Chapter 14 of this Ordinance.)
 - a. In any zoning district, a bee apiary may be kept as long as the following guidelines are adhered to:
 - 1) Lot size and colony density: parcels up to seven thousand five hundred (7,500) square feet of lot area qualify the parcel to accommodate one (1) apiary; one additional apiary may be harbored for each additional five thousand (5,000) square feet of lot size above the first seven thousand five hundred (7,500) square feet of lot size. The maximum number of apiaries allowed, regardless of lot size, is four (4);
 - 2) Setbacks: No apiary shall be allowed to be closer than ten (10) feet to any property line, right-of-way or public sidewalk. No apiary may be placed within a front yard or rear yard setback;
 - 3) Flyway barriers: A solid fence or wall of vegetation with a height of between five (5) and six (6) feet (inclusive), must be placed a minimum of five (5) feet and maximum of seven (7) feet from the front entrance of the apiary, extending outward between three and one-half (3 ½) and four and one-half (4 ½) feet in both directions from the apiary centerline;
 - 4) A clean water source must be available within the confines of the parcel, designed in a manner conducive to bee usage and which prevents any significant number of bees from using a water source on an abutting property;
 - 5) Any apiary identified as a nuisance, determined by aggressive behavior of any bees servicing the beehive or bees swarming on neighboring properties, must have its use immediately terminated on the parcel of land.
 - 6) A property owner must register all apiaries with the White County Area Plan Staff. A registration fee shall be required before establishment of any apiaries as provided for in the Area Plan Official Fee Schedule;

4. 4-H Animals

- a. Any animal, fish, fowl or insect bred or raised in conjunction with a 4-H project is permitted in any A-1, A-2 or RR District and is exempt from the limitations, restrictions and requirements of Subsection “b” and “c” below.
- b. When related to a 4-H or school project, any resident in an L-1, R-1, R-2, R-3 or R-4 district is allowed to habitat rabbits, ducks or chickens subject to the following restrictions:
 - 1) No more than two (2) of any animal per project is permitted on site at any given time;
 - 2) Upon request by the Executive Director, Area Plan Commission or Area Board of Zoning Appeals, a property owner or project participant must provide written certification from a 4-H or school official identifying the animal(s) as part of 4-H or school project; such certification must include the project’s completion date;
 - 3) All animals must be disposed of in a humane manner within thirty (30) days from the project’s completion date;
 - 4) All 4-H/school animal project sites must take all reasonable steps to prevent the site from creating a neighborhood nuisance; and,
 - 5) All animals must be restrained in a fashion which keeps them a minimum of six (6) feet from any side or rear property line; no containment area may encroach a front setback.
- c. Other
 - 1) When related to a 4-H project, a resident is allowed to habitat any animal, fish, fowl or insect, which is kept inside a building or structure at all times and confined to a cage, tank or pen.
 - 2) Any animal, fish, fowl or insect covered under this Ordinance subsection may not exceed twenty (25) pounds at adult weight.

4.3.5 **Swimming pools**

All swimming pools shall be in compliance with IAC 20-4-27.

4.3.6 **Management offices**

Management offices in multi-family dwellings and other facilities normally associated with tenants' convenience, such as vending machines and washing machines are permitted, provided there is no exterior display of such sale of goods.

4.3.7 **Use, storage or parking of recreational vehicles**

No recreational vehicle shall be maintained in White County as a permanent office or residence, nor shall a recreational vehicle be permanently affixed to a property unless it is properly located within an approved campground, approved manufactured home park or AED district.

“Permanently Affixed” shall be defined as when:

- a) electricity is hardwired to the vehicle; or
- b) the vehicle is directly attached to a well or septic; or
- c) the vehicle is secured to a concrete foundation

A recreational vehicle may be stored or parked on any property governed by this Ordinance, provided that it does not constitute a nuisance or fire hazard and provided the following conditions are also met:

- A. In any district, the wheels or any similar transporting devices of any recreational vehicle shall not be removed except for repairs, nor shall such vehicle be otherwise permanently fixed to the ground in a manner that would prevent ready removal of said structure.
- B. RV Parking and Storing in a Residential or A-1 district:
 - 1. In any residential or A-1 district a recreational vehicle, not in use, may be stored or parked behind or along side a principal or accessory structure or in any driveway or designated parking area. In no instance shall any part of any such vehicle be located closer than four (4) feet to any property line.-
 - 2. Not more than one (1) personal Recreational Vehicle and one visiting Recreational Vehicle may be parked or stored in the open at any one time. Visiting RV parking and storage is restricted to no more than fourteen (14) consecutive days or forty-five (45) days in any three hundred sixty-five (365) day period. There is no limitation to the parking or storage of a personally owned Recreational Vehicle. There is no limitation to the parking or storage of any RV as long as the RV is fully enclosed within a structure.
- C. RV "Use" in a Residential or A-1 district:
 - 1. On any lot within any incorporated municipality or within the defined limits of the Town of Buffalo or Idaville, and which is assigned with a residential or A-1 district designation, an RV is restricted to parking and storage only. Temporary, recreational use may be allowed but only with written authorization of the Executive Director and for a period not to exceed forty-five (45) days in any three hundred sixty-five (365) day rolling period.
 - 2. On any lot in an unincorporated area of White County, excluding the town limits of Idaville and Buffalo, and which lot lies within a residential or A-1 zoning district, no more than one (1) personally owned recreational vehicle and one (1) visiting recreational vehicle shall be permitted to be used at any one time, This restriction does not apply to an approved campground or manufactured home park for which there are no restrictions. Use is restricted to the property owners, property owner family members or personal friends. Rental of the unit for any duration, non-recreational use and residential use is strictly prohibited. For purposes of this section, a recreational vehicle shall be considered to be in "use" if the recreational vehicle is connected to gas, water, electric or sewer. Any Recreational Vehicle in use must be located in the rear yard, side yard, a designated parking area or driveway. On a vacant lot, the unit can be located anywhere as long as it is no closer than ten (10) feet to the front property line or right-of-way line; whichever is most restrictive and no closer than four (4) feet to any side or rear property line. Visiting recreational vehicles shall be limited to one (1) and shall only be permitted for a maximum of fourteen (14) consecutive days, not to exceed twenty-eight (28) days in any three hundred sixty-five (365) day rolling period.

- D. In a business or industrial district, there shall be no limit to the number of recreational vehicles stored outdoors.
- E. At no time shall a parked or stored recreational vehicle in a business or industrial district be occupied or used for living, sleeping or housekeeping purposes.
- F. Notwithstanding the provisions of this Section, recreational vehicles may be parked anywhere on a residential premises for loading or unloading purposes, provided that it is not longer than twenty-four (24) hours at one time, and no more than twice per week, regardless of the number of hours spent parked on the premises.

4.4 TEMPORARY USES

Temporary Uses may be allowed in accordance with the requirements of this Chapter. Refer to Appendix A, Official Schedule of Uses, for a list of temporary uses permitted by district.

4.4.1 General provisions

- A. The duration of a temporary use permit shall be as prescribed below. An extension of any temporary use permit may be requested.
- B. Temporary Uses and/or structures shall take place or be located in a manner so as not to create a nuisance or safety hazard as determined by the Executive Director.

C. Allowed Temporary Use Provisions – Temporary Use Permit Required

The following uses are allowed subject to the established regulations:

1. Professional or Business office. Maximum time permitted: 18 months.
2. Portable concrete or cement batching plant, such use must be both incidental and necessary to construction. Maximum time permitted: 18 months.
3. Construction yard or sawmill, such use must be both incidental and necessary to construction. Maximum time permitted: 18 months.
4. Parking lot designated for a special event. Maximum time permitted: 30 days.
5. Bazaars, carnivals, circus, entertainment facility (commercial), outdoor theater, mechanical rides, petting zoo, sporting events (for profit) and similar uses, except as excluded in Section 4.4.1 D. Maximum time permitted: 30 days.
6. Flea market. Maximum time permitted: 10 days.
7. Placement of a mobile home or manufactured home as an on-site office during construction and development or for other non-construction use. Permit requirement only applies to those requests which are located outside of a local municipality, but within the jurisdiction of the White County Area Plan Commission. Maximum time permitted: 18 months.
8. A mobile or manufactured home or may be moved onto a lot and be used as a temporary residence per Section 3.4.1 of this Ordinance.

9. A recreational vehicle may be moved onto a lot and used as temporary construction housing, but may not be permanently affixed as defined in Section 4.3.7. Maximum time permitted: 18 months.
 10. Portable Storage in a non-residential zoning district. Maximum time permitted: 30 days (for residential zoning districts refer to Chapter 8, Section 8.6.3 of this Ordinance).
 11. Other similar temporary uses approved by the Executive Director and attached with such time period, conditions and safeguards as the Executive Director may deem necessary.
- D. Allowed Temporary Use Provision – Temporary Use Permit Not Required
1. Municipality, Town or County sponsored or approved festival or event.
 2. Church, school, not-for-profit or charitable organization bazaar, bake sale, garage or yard sale, retail sales or similar use. Maximum time permitted: 7 days per event.
 3. Christmas tree sales and agricultural roadside stands.
 4. Portable agricultural product sales (from truck, cart, trailer or another portable vehicle).
 5. Auction. Maximum time permitted: 3 days per auction.
- E. A Temporary Use Permit may be rescinded should the use and/or structure result in a safety hazard or not be kept in a well-maintained condition.
- F. Temporary uses excluded from this requirement:
1. Tent use
 2. On-premise retail structures utilized by a retail establishment

4.4.2 Standards

- A. Adequate access and off-street parking facilities shall be provided for each temporary use. No such access or off-street parking shall interfere with traffic movement on adjacent streets.
- B. No public address systems or other noise producing devices associated with a temporary use shall be permitted in a residential district.
- C. Any flood lights or other lighting associated with the temporary use shall be directed upon the premises and shall not adversely impact adjacent properties.
- D. No banners, pennants or unnecessary signs associated with a temporary use shall be permitted in any residential district.
- E. The lot shall be put in clean condition devoid of temporary use remnants upon expiration of the temporary use permit.

4.5 **NONCONFORMING USES AND STRUCTURES**

Within the districts established by this Ordinance, including any amendments hereto, there may exist lots, uses, or structures which were lawful before the effective date of the ordinance, but which would be prohibited, regulated or restricted under the terms of this Ordinance. It is the intent of this Section to allow all non-agricultural nonconforming lots, uses, or structures to continue until they are removed, but not to encourage their survival. Nothing in this Section shall be deemed to prevent the strengthening, or restoring to a safe condition, any building or part thereof which has been declared to be unsafe by any official charged with protecting the public safety. The existence of nonconforming lots, uses and structures is not to be used as grounds for adding similar lots, uses or structures which would otherwise be prohibited. It is further the intent of this Ordinance that no nonconforming use or structure shall be enlarged upon, expanded or extended, nor be used as grounds for adding other structures or uses which are prohibited elsewhere in the same district. All nonconforming situations shall be governed by this Section.

4.5.1 **General provisions**

A. **Illegal nonconforming uses**

Illegal nonconforming uses existing at the time this Ordinance is enacted shall not be validated by virtue of its enactment.

B. **Incompatibility of nonconforming uses**

Nonconforming uses are declared by this Ordinance to be incompatible with permitted uses in the districts in which the use is located. With the exception of legally nonconforming agricultural uses and structures, a nonconforming use of a structure and land in combination shall not be extended or enlarged after passage of this Ordinance by attachment on a building or premises of additional signs intended to be seen from off the premises, or by the addition of other uses of a nature which would be generally prohibited in the district in which the use is located.

C. **Avoidance of undue hardship**

To avoid undue hardship, nothing in this Ordinance shall require any change in the plans for the construction or designated use of a building for which a Building Permit or an Improvement Location Permit, provided that the permit was issued prior to the effective date of adoption of this Ordinance, as amended from time to time, and upon which actual construction has begun. Actual construction is hereby defined as work done which is beyond the preparation stage and into that stage where the changes or additions are made permanent. Where demolition or removal of an existing building has been substantially begun preparatory work shall be carried on diligently.

D. **Consistent with IC 36-7-4-616, an agricultural use of land that constitutes an agricultural nonconforming use may be changed to another agricultural use of land without losing agricultural nonconforming use status. In addition, an agricultural nonconforming use shall not be restricted or required to obtain a variance or special exception so long as an agricultural nonconforming use has been maintained for three (3) years in a five (5) year period.**

E. **Repairs and maintenance**

Legally nonconforming agricultural uses excluded, work may be done on any nonconforming structure or portion of a structure containing a nonconforming use, in any period of twelve (12) consecutive months on ordinary repairs, or on repair or replacement of non-bearing walls, fixtures, wiring or plumbing, provided that the cubic content existing when it became nonconforming shall not be increased. Nothing in this Chapter shall be deemed to prevent the strengthening or restoring to a safe condition of any building or part thereof declared to be unsafe by any official charged with protecting the public safety, upon order of the official.

F. Unsafe Buildings

If any nonconforming structure or portion of a structure containing a nonconforming use becomes physically unsafe or unlawful by reason of physical condition, it shall not thereafter be restored, repaired or rebuilt except in conformity with the regulations of the district in which it is located.

4.5.2 Single nonconforming lots of record

A nonconforming lot is a lot which does not meet the minimum requirements in Appendix B for lot size and lot width, and which otherwise lawfully existed at the time those minimum requirements became effective.

In any district in which single-family dwellings are permitted, a single-family dwelling and customary accessory building(s) may be erected on a nonconforming lot if the legally created lot was either recorded in separate ownership or included in a recorded subdivision on or before August 4, 2008, the effective date of this ordinance; provided, however, that the single-family dwelling and its accessory building(s) meet all other requirements of this ordinance, except for lot size and lot width, including, but in no way limited to, the setback requirements in Appendix B.

A nonconforming lot changed to a conforming lot shall never be changed back to a nonconforming lot.

4.5.3 Nonconforming lots of record in combination

If two (2) or more lots or a combination of lots and portions of lots with continuous frontage in single ownership, and if all or part of the lots containing no structures do not meet the requirements established for lot width and area, at the time of adoption of this Ordinance as amended from time-to-time, the lands involved shall be considered to be an undivided parcel for the purposes of this Ordinance. No portion of the parcel shall be used or sold in a manner which diminishes compliance with the lot width and area requirements established by this Ordinance, nor shall any division of a parcel be made which creates a lot with width or area below the requirements stated in this Ordinance.

4.5.4 Nonconforming uses of land

Where, at the time of adoption of this Ordinance as amended from time-to-time, a lawful use of land exists which would not be permitted by the regulations imposed by this Ordinance, the use may be continued so long as it remains otherwise lawful. Said legally nonconforming use shall be subject to the following provisions:

- A. With the exception of a legally nonconforming agricultural use, no nonconforming use shall be enlarged or increased, nor extended to occupy a greater area of land than was occupied at the effective date of adoption or amendment of this Ordinance.

- B. With the exception of a legally nonconforming agricultural use, no nonconforming use shall be moved in whole or in part to any portion of the lot or parcel other than that occupied by the use on the effective date of adoption or amendment of this Ordinance.
- C. With the exception of a legally nonconforming agricultural use, any nonconforming use of land that is discontinued or abandoned for more than one (1) year (except when government action impedes access to the premises), any subsequent use of the land shall conform to the applicable regulations of this Ordinance.

4.5.5 Nonconforming structures

Where a lawful structure exists on the effective date of adoption or amendment of this Ordinance which could no longer be built under the terms of this Ordinance, the structure may be continued so long as it remains otherwise lawful. Said legally nonconforming structure shall be subject to the following provisions:

- A. With the exception of a legally nonconforming agricultural structure, no nonconforming structure may be enlarged or altered in a way which increases its nonconformity. However, any legally nonconforming structure or portion thereof may be altered to decrease its nonconformity.
- B. No nonconforming structure or nonconforming portion of the structure having been destroyed or altered by any means to the extent of more than fifty (50) percent of the appraised value of the building as it was prior to the damage or alteration, shall be reconstructed except in conformity with the provisions of this Ordinance. In the case of a residential nonconforming structure in a business district, the structure may be reconstructed as a residential structure provided that the new structure is of the same size and dimension as the residential structure being replaced.
- C. Any legally nonconforming structure moved for any reason for any distance shall thereafter conform to the regulations for the district to which it is relocated.

4.5.6 Nonconforming uses of structures or structures and land in combination

Where legal nonconforming use status applies to a structure and land in combination, an intentional removal or alteration of the structure or its use, which made the structure or use a nonconforming structure or use shall also eliminate the legal nonconforming status of the land. Legally nonconforming uses located in structures specifically constructed or modified to suit only such use are exempt from this provision and may be resumed if the structure has not been intentionally altered to serve other uses, used to house a permitted use, or used to house another nonconforming use.

A legal nonconforming use of structure and/or land in an I-3 district shall preserve its previously legal status and all rights and privileges granted by this ordinance in common with any other legal conforming use of structure and/or land.

4.5.7 Nonconforming districts

At the time of adoption of this Ordinance, as amended from time to time, the following zoning districts shall no longer be in existence. Unless otherwise noted, property zoned under these districts will continue to be zoned as such until such time as the property is rezoned to a conforming district. These nonconforming districts, including their restrictions and permitted uses include:

A. F-1 Flood Plain District

The F-1 District was provided to protect areas that are prone to flooding. The Conservation and Flood Plain Overlay District, including the permitted uses and development standards for a C-1 District set forth in Appendices A and B respectively, is the most similar to the former F-1 District. Under this Ordinance, permitted uses in F-1 Flood District will be replaced by uses permitted, either by right or special exception, in a C-1 District, as prescribed by Appendix A, Official Schedule of Uses.

B. R-5 Rural One and Two-Family Residential District

The R-5 District was provided for the development of one and two-family residential dwellings. The L-1 Lake District and the R-2 Single and Two-Family Residential District, including the development standards and permitted uses for these Districts set forth in Appendices A and B respectively, is the most similar to the former R-5 District. Under this Ordinance, permitted uses in the R-5 District will be replaced with uses permitted, either by right or by special exception, in an L-1 District, as prescribed by Appendix A, Official Schedule of Uses, if the lot abuts a lake or river area. For lots that do not abut a lake or river area, the uses permitted in the R-5 District will be replaced with uses permitted, either by right or by special exception, in an R-2 District, as prescribed by Appendix A, Official Schedule of Uses.

C. Rural Multi-Family Residential District

The R-6 District was provided for the development of multi-family residences in rural areas. The R-4 Mobile Home and Manufactured Home Park Residential District, including the development standards and permitted uses for the R-4 District set forth in Appendices A and B respectively, is the most similar to the former R-6 District. Under this Ordinance, permitted uses in the R-6 District will be replaced with uses permitted, either by right or by special exception, in an R-4 Mobile Home and Manufactured Home Park Residential District as prescribed by Appendix A, Official Schedule of Uses.

4.5.8 **Nonconforming manufactured and mobile homes**

This provision shall apply to manufactured homes and mobile homes located within White County, outside of municipal jurisdiction. Any manufactured home or mobile home located within a municipality shall be subject to the regulations of said municipality.

Manufactured homes and mobile homes are designed to be movable rather than fixed structures. Therefore, when a manufactured home or mobile home is a nonconforming use, the requirements of this section apply, rather than those of 4.5.1, 4.5.4, 4.5.5, and 4.5.6.

A. Nonconforming manufactured homes and mobile homes permitted to remain

Nonconforming manufactured homes and nonconforming mobile homes are ones which are not permitted in Appendix A, Schedule of Uses, to be located in the zone in which it is in fact located, and which otherwise lawfully existed at the time the applicable portion of Appendix A became effective. An otherwise lawful manufactured home or mobile home made a nonconforming manufactured home or mobile home by this Ordinance or an amendment to it, may be continued under each of the following terms and conditions:

1. The dimensions and size of the manufactured home or mobile home are not increased beyond what they were at the time this Ordinance or its amendment became effective and the footprint for the manufactured home or mobile home is not changed; provided, however, that the footprint of the manufactured home or mobile home may be changed and/or the dimensions and size of the manufactured home or mobile home may be increased beyond what they were at the time this Ordinance or its amendment became effective if the standards for setbacks, maximum lot coverage, and maximum structure height set forth in Appendix B for the particular zone in which the manufactured home or mobile home is located can be met.
2. No additional structure serving the nonconforming manufactured home or nonconforming mobile home is erected; provided, however, that a permitted accessory structure may be erected if the standards for setbacks, maximum lot coverage, and maximum structure height for principal structures and accessory structures set forth in Appendix B for the particular zone in which the manufactured home or mobile home is located can be met.
3. If the nonconforming use is discontinued for a period of twelve (12) months or more, the legally nonconforming mobile home status expires, and any subsequent use of that property shall conform to the requirements of the Ordinance including, but in no way limited to, setbacks, lot width, lot size, and Appendix A.
4. If the nonconforming manufactured home or nonconforming mobile home is substantially damaged or destroyed by any means to the extent that repairs or replacement would equal or exceed fifty percent (50%) of the market value of that manufactured home or mobile home, the nonconforming manufactured home or nonconforming mobile home may be replaced in accordance with Section 4.5.8(B) below provided that substantially damaged or destroyed nonconforming manufactured home or nonconforming mobile home is replaced within one (1) year of the date substantial damage or destruction is incurred. If replacement is not made within that time frame, the legally nonconforming manufactured home or mobile home status shall expire, and any subsequent use of the property shall conform to the requirements of the Ordinance including, but in no way limited to, setbacks, lot width, lot size, and Appendix A.
5. A nonconforming manufactured home or nonconforming mobile home changed to a conforming or permitted use shall never be changed back to a nonconforming manufactured home or nonconforming mobile home.
6. A nonconforming manufactured home or nonconforming mobile home shall not be replaced by any other kind of nonconforming use.

B. Replacement of nonconforming manufactured home or mobile home

A nonconforming manufactured home or nonconforming mobile home may be replaced with a Type I or Type II manufactured home or mobile home provided that the standards set forth in section 3.3 of the Ordinance and 4.5.8 (A) above are met, and the manufactured home or mobile home replaced is removed from the subject property within thirty (30) days of its replacement.

4.5.9 Nonconforming decks – lake properties

Any deck constructed prior to March 8, 2010, shall be permitted “as built” with regards to front, side and rear yard setbacks. Nothing in this Ordinance shall conflict with this stipulation.

CHAPTER 5 PLANNED UNIT DEVELOPMENT

5.0 PURPOSE AND INTENT

5.0.1 Purpose

It is the expectation of the County and participating municipalities that rezoning a property or properties to a Planned Unit Development (PUD) District will result in higher quality developments than would otherwise be required of a development in the existing zoning district(s). More specifically, the purposes of a PUD are to:

- A. Encourage a more creative approach in land and building site planning.
- B. Promote variety in the physical development pattern of the community; including mixed-use development.
- C. Use design to provide compatibility between areas of different land uses and development intensities within the PUD.
- D. Enhance the appearance of developments by conserving areas of natural beauty and natural open space.
- E. Encourage renewal of older areas where new development and restoration and rehabilitation are needed to revitalize the areas.
- F. Promote architecture that complements the surrounding areas.
- G. Permit special consideration of property with unique features, such as historical significance, unusual topography, landscape amenities, and size and shape.
- H. Simplify processing of development proposals for developers and the appropriate legislative body by providing for concurrent review of land use, subdivisions, public improvements, and siting considerations.
- I. Encourage developments that exceed the development standards of the previous zoning district to create a high quality development.

5.0.2 Intent

The intent of the Planned Unit Development (PUD) is to provide a means of achieving innovative and creative design, and flexibility of development through an alternative zoning procedure when sufficiently justified under the provisions of this Chapter. Planned Unit Developments are intended to encourage a higher quality of design aesthetic and include more amenities while accommodating development with mixed or varied uses. The most desirable site may be unusual in their topography or unique in their setting. This may include land which exhibits difficult or costly development problems. A PUD may be developed with a variety of residential types and non-residential uses. A PUD may contain both individual building sites and common property which are planned and developed as a unit. The end result shall fulfill the objectives of the comprehensive plan and other planning policies of the County and participating municipalities while departing from the application of the district regulations. It is not

intended that the appropriate legislative body automatically grant the concept plan of a development proposed by a petitioner. The Area Plan Commission shall approve only such plans of a development that are consistent with the public benefits resulting from planned developments. Therefore, the appropriate legislative body may require as a condition of approval and subsequent amendment of the zoning map, conditions, limitations or design factors which will promote proper development of a planned unit development. The Area Plan Commission shall discourage the use of a PUD as a means of circumventing the rezoning/subdivision process or to avoid the standards and requirements of this ordinance or the Subdivision Control Ordinance.

5.1 REZONING TO A PUD

A Planned Unit Development (PUD) may be granted as a rezone in any zoning district by the appropriate legislative body, should said body determine that the Planned Unit Development is in the best interest of the community, and that it complies with the intent of the standards established in this Ordinance. The Area Plan Commission and appropriate legislative body may require conditions of approval or design considerations that will promote proper development or benefit to the community.

5.2 REQUIREMENTS FOR A PUD

5.2.1 Ownership

The area designated on the PUD map must be a tract of land under single ownership or demonstrated control at the time of application. Single control of property under multiple ownerships may be accomplished through the use of enforceable covenants and commitments, which run to the benefit of the Area Plan Commission.

5.2.2 Preliminary PUD plan

The Preliminary Plan shall indicate the land use, development standards, and other applicable specifications of this Ordinance, which shall govern the PUD. If the Preliminary Plan does not address specific land use, development standards or other specification of this Ordinance (e.g. parking, landscaping, lighting, etc.), the applicable standard or regulation of the previous zoning district shall apply. The location of a PUD shall be designated on the Zoning Map and adopted pursuant to this Chapter. Improvements made to the proposed site prior to Preliminary PUD approval shall constitute a violation of the White County Zoning Ordinance.

5.2.3 Final PUD plan

The Final Plan shall show the location of all improvements.

5.2.4 Compliance with this Ordinance

The Preliminary Plan and Final Plan must comply with all required improvements, construction standards, design standards and all other engineering standards contained within this Ordinance and other pertinent regulations, except where specifically carried through the provisions of this Chapter.

5.2.5 Permitted uses

Uses permitted in a PUD shall be subject to the approval of the Area Plan Commission and the appropriate legislative body.

5.3 PUD SUBMITTAL AND APPROVAL PROCESS

The PUD application shall be accompanied by all plans and documents.

5.3.1 Procedures for Preliminary PUD Plan

A. Pre-application meeting

The applicant shall meet with the Executive Director no less than one (1) month prior to the anticipated Area Plan Commission docket deadline.

B. Preliminary Plan PUD submittal requirements

The Preliminary Plan PUD submittal shall include the following as applicable. Failure to submit any of the following information may result in an incomplete application. Only complete applications shall be considered for placement on the Area Plan Commission docket.

1. General project information

- a. The owner, contract purchaser, or others having an economic interest, for which a PUD is sought, must file a complete application with the Executive Director.
- b. A complete application must include full sized documents and drawings. The submission may be composed of one (1) or more sheets and shall include the following.
 - 1) Name, address and telephone number of the owner. If property ownership is in trust, the name and address of each person or entity owning an interest in the property, and the extent of such ownership interest unless any of such entities is a corporation or a partnership, in which case only those persons owning an interest in excess of fifty (50) percent in such corporation or partnership need be identified by name, address and extent of interest.
 - 2) Name, address and telephone number of the applicant including the name and address of each person or entity owning an interest in the property and the extent of such ownership interest unless any of such entities is a corporation or a partnership, in which case only those persons owning an interest in excess of fifty (50) percent in such corporation or partnership need be identified by name, address and extent of interest. For purposes of this Chapter, the term ownership interest shall include any legal or equitable interest held at the time of the application in the real property which is the subject of the application. The application must include the signature of the owner(s).

- 3) All drawings shall be of an appropriate scale¹.
 - 4) North point, designated as true north.
 - 5) Date of preparation of original drawing and the date of any revisions.
 - 6) The name of the development, with the words "Preliminary PUD Plan"
- c. Payment of a non-refundable application fee as designated in the fee schedule
 - d. Every application must be accompanied by payment for a development review fee in such an amount as prescribed by the Official Fee Schedule, as amended from time to time.
2. Existing conditions and determination of best land use(s)
 - a. A site location map showing the boundary of the proposed PUD
 - b. A legal description of each parcel of property subject to the petition
 - c. Parcel ID numbers
 - d. Relative address
 - e. Existing (prior to rezoning to a PUD) zoning districts and current use of land on the site and on adjacent property within six hundred and sixty (660) feet of the subject site.
 - f. All existing or previously platted streets on the site
 - g. Existing easements, including location, width and purpose
 - h. Other rights-of-way, including railroads and utility rights-of-way, showing existing improvements, if any.
 - i. Existing permanent buildings and structures on the site
 - j. Environmental features including water courses, sinkholes, lakes, ponds, floodplains, wooded areas, and wetlands
 - k. Existing vegetation to be preserved and the locations and nature
 - l. Future land uses
 - m. Other existing conditions data as may be required by Executive Director, Area Plan Commission, the PUD Committee, or the appropriate legislative body.

¹ All drawings shall be at a scale not smaller than one inch equals fifty feet (1"=50') with a scale of one inch equals thirty feet (1"=30') being preferred. Any other scale must be approved by the Executive Director. No individual sheet or drawing shall exceed twenty-four inches by thirty-six inches (24" x 36").

3. Written description of district

The applicant shall provide written narrative description of the PUD describing the character of the development in the PUD, the intent and desired effect of the development, the manner in which the development has been planned to take advantage of the flexibility of the PUD regulations, the superior benefits that would accrue to the residents/users of the development, and all relief sought from the standard application of district requirements in conjunction with the project. The written narrative description should also include any information relative to the anticipated build-out, or completion, of the project, including any phasing of development.

- C. Preliminary Plan PUD review procedures

The review procedure for a Preliminary PUD Plan shall be consistent with the procedures described as follows.

1. Authority

The appropriate legislative body has the authority to grant a rezone for a PUD from the Area Plan Commission in accordance with the provisions of this Chapter.

2. Initiation

- a. The owner of the property, lessee, or contract purchaser of at least fifty (50) percent of the land area for which a PUD is sought may initiate a request for a rezone for a PUD.
- b. The Preliminary Plan, Draft PUD Ordinance and application for the PUD shall be submitted to the Executive Director or Area Plan Commission Office, after certifying the application to be complete, shall initiate a review by the PUD Committee and Technical Review Committee.
- c. The applicant shall attend a joint meeting of the PUD Committee and Technical Review Committee which shall make a report and recommendation to the Area Plan Commission.
- d. The application and the results shall be forwarded to the Area Plan Commission for its consideration, public hearing and recommendations together with the Executive Director's report and such other documents as may be pertinent to the PUD.
- e. The applicant shall be responsible for notice in the newspaper in accordance with IC 5-3-1 as amended.

3. Procedure for decision – Area Plan Commission and appropriate legislative body action

- a. Public hearing

The Area Plan Commission shall hold a public hearing on an application for a PUD. At the hearing, all interested parties shall have an opportunity to be heard.

- b. Area Plan Commission and appropriate legislative body action
 - 1) Within thirty (30) days after the close of the public hearing, the Area Plan Commission shall vote to recommend approval or denial, or approval with conditions on the PUD to the appropriate legislative body by a simple majority of those Area Plan Commission members present and voting. The Area Plan Commission shall provide written certification to the appropriate legislative body.
 - 2) The appropriate legislative body shall act to approve, deny, or approve with conditions the PUD District within ninety (90) days of the legislative body's first meeting following receipt of the certification of Area Plan Commission recommendation.

4. Written findings of fact

The Area Plan Commission in its recommendations with regard to an application for a PUD District must set forth specific report of determinations of fact.

5. Conditions of approval

The Area Plan Commission may recommend and the appropriate legislative body may impose conditions in authorizing a PUD District to make such use more compatible with the use, enjoyment and development of adjacent and nearby properties, to make the use more compatible with the character of the area in which it is located and to eliminate any adverse effect on adjacent and nearby properties and the neighborhood. Any such conditions must be set forth as part of the action approving the PUD District. Such written commitments shall be recorded and made part of the PUD District.

- D. Public hearing and actions on Preliminary PUD Plan

1. Review and actions on the part of the Area Plan Commission and appropriate legislative body shall take place in accordance with this Chapter. The Area Plan Commission may recommend approval, disapproval or approval with amendments, conditions or restrictions with respect to the preliminary PUD plan.
2. If the preliminary PUD plan is approved by the appropriate legislative body, it shall adopt a PUD zoning district designation approving said preliminary plan and plat, if applicable, with conditions as specified and authorizing the preparation of the final plan and plat, if applicable. If a PUD preliminary plan is approved, it shall become effective and its location shall be shown on the Zoning Map. Upon such amendment of the Zoning Map, the use and development of the site shall be governed by the PUD Preliminary Plan, subject to approval of a PUD Final Plan.
3. All conditions imposed as part of any PUD shall run with the land and shall not lapse or be waived as a result of a subsequent change in tenancy or ownership of any or all of said areas, provided, however, that nothing herein shall be construed to limit the right of the developer, his successors or assignee to sell property in said PUD, except for such conditions imposed upon said common open space areas.

4. Approval of the preliminary plan by the appropriate legislative body does not constitute final PUD plan approval, but authorizes submission of a final development plan for approval. Approval of the preliminary plan shall be valid for a period of two (2) years from the date of the appropriate legislative body approval. If a final plan approval is filed in phases, each subsequent phase shall be filed for within two (2) years of the prior phase's approval. If an application for final plan approval for all or a part of a geographic portion of the preliminary plan has not been filed within the two (2) years period, or if a developer has not requested and received approval of a one (1) year extension from the Area Plan Commission, then a resubmission of the preliminary plan shall be required, in accordance with the process of this Section, if the applicant intends to file for final plan approval. In no case shall an Improvement Location Permit or a Building Permit be issued prior to Final PUD Plan approval.

5.3.2 Amendments to an approved Preliminary PUD Plan

A. Minor changes

Minor changes in the location, sitting and height of buildings and structures may be authorized by the Area Plan Commission during the PUD final plan process without additional public hearings if required by engineering or other circumstances not foreseen at the time the concept plan was approved. No change authorized by this sub-section may cause any of the following:

1. A change in the use, intensity or character of the development;
2. A greater than ten (10) percent increase in overall coverage of structures;
3. A greater than ten (10) percent increase in the intensity of use;
4. Five (5) percent or greater reduction in approved open space;
5. Five (5) percent or greater reduction of off-street parking and loading spaces; or
6. A ten (10) percent or greater reduction in required pavement widths.

B. Major changes

All other changes in use, or rearrangement of lots, blocks, building tracts, or any changes in the provision of common open space and changes other than listed above in Section 5.302(A), may be made only if they are shown to be required by changes in conditions that have occurred since the concept plan was approved or by changes in community policy. Said changes may be approved by the appropriate legislative body after report of Executive Director and recommendation by the Area Plan Commission.

1. Any changes to the approved final plan must be recorded as amendments in accordance with the procedures and requirements of Chapter 12, Administration.
2. If there are changes to the concept plan and concept approval granted to the PUD by the Area Plan Commission, but not final approval by the appropriate legislative body, then the applicant is required to be placed back on the Area Plan Commission docket for a public hearing. Applicant shall provide public notice to residents in accordance with the requirements of IC 5-3-1 as amended.

3. If after a second recommendation from the Area Plan Commission, the legislative body denies Preliminary PUD Approval, the applicant shall be required to re-file his application subject to the requirements of this Chapter as if it was an entirely new application.

5.3.3 Procedures for Final PUD Plan

A. Pre-application meeting

The applicant shall meet with the Executive Director no less than one (1) month prior to the anticipated Area Plan Commission docket deadline.

B. Final PUD Plan submittal requirements

The final plan shall include the required information described in this Section. In addition to these submittal requirements, the following shall be submitted.

1. Final Development Plan

- a. A site location map showing the boundary of the proposed PUD
- b. A legal description of each parcel of property subject to the petition
- c. A current plat of survey prepared by a land surveyor registered in the State of Indiana.
- d. Parcel ID numbers
- e. Relative address
- f. Existing (prior to rezoning to a PUD) zoning districts and current use of land on the site and on adjacent property within six hundred and sixty (660) feet of the subject site.
- g. All existing or previously platted streets on the site
- h. Existing easements, including location, width and purpose
- i. Other rights-of-way, including railroads and utility rights-of-way, showing existing improvements, if any.
- j. Existing permanent buildings and structures on the site
- k. Utilities on the site indicating the location, size and invert elevations of storm and combined sewers; the size and location of sanitary sewers; the size and location of water mains; the location of fire hydrants; the direction and distance to the nearest usable water mains and sewers; and the location of private utilities such as gas, electric, and telephone lines and easements. The data can be summarized in a table; however the location of the utilities shall be documented on the map.
- l. Topographic data for the site consisting of existing contours at two-foot intervals.
- m. Environmental features including water courses, sinkholes, lakes, ponds, floodplains, wooded areas, and wetlands

- n. Existing vegetation to be preserved and the locations and nature
 - o. Future land uses
 - p. The location and general design of new lots, landscaping, including fencing, berming and walls, trash collection facilities, any proposed streets, major storm water drainage facilities, main utility lines and facilities, and other features deemed necessary by the Area Plan Commission and appropriate legislative body on all of the contiguous property holdings of such developer, his/her agents, trustees, beneficiaries, or owners, whether or not said contiguous land holdings are intended for immediate development;
 - q. Other existing conditions data as may be required by Executive Director, Area Plan Commission, the PUD Committee, or the appropriate legislative body.
2. Written description of district

The applicant shall provide written development standards that shall include, at a minimum, the following information that will be incorporated into a written PUD Ordinance as described in sub-section PUD Zoning Designation Ordinance:

- a. Narrative description of the PUD describing the character of the development in the PUD, the intent and desired effect of the development, the manner in which the development has been planned to take advantage of the flexibility of the PUD regulations, the superior benefits that would accrue to the residents/users of the development, and all relief sought from the standard application of district requirements in conjunction with the project;
- b. Gross and net area of tract;
- c. Total number of dwelling units proposed;
- d. Lot size for each lot summarized in a table based on project area;
- e. Height of structures;
- f. Setbacks;
- g. Floor area or lot coverage;
- h. Open space;
- i. Project density;
- j. Number of off-street parking spaces proposed;
- k. The location and distance between buildings and structures;
- l. The proposed location and general use of common ground (if any), including recreational areas, plazas, pedestrian ways and major landscape areas including buffer areas;
- m. General landscaping information including number of trees/shrubs, approximate size (at the time of planting) of all plant material by type (such as

deciduous/coniferous trees, ornamental trees, shrub masses and ground cover including grassed areas, ivies, etc.). Landscaping within parking areas shall be included;

- n. Quantification of site area by building coverage, parking, loading and driveways, and common retention/detention, floodplain and/or natural areas;
 - o. The general type and size of all retaining walls, fences and earth berms;
 - p. The general type and size of all refuse collection facilities including screening to be provided;
 - q. Design of all project signage, including project marketing signage, square footage of sign, height, type of sign;
 - r. Describe site lighting including the type of lighting and minimum and maximum light values;
 - s. Project report to include an explanation of the character of the proposed development, verification of the applicant's ownership or contractual interest in the subject site and proposed development schedule;
 - t. Proposed covenants, if any, to govern the use and maintenance of the development and ensure the continued observance of the provisions of the PUD; and
 - u. Additionally, for a proposed PUD that is of a larger size and complexity that impact on the community is not easily ascertained, the Area Plan Commission may require that the petitioner supplement the filing with an impact assessment. The factors that are impacted will be determined at the time the Area Plan Commission reviews the preliminary plan.
 - v. The applicant may be required to provide, at the applicant's expense, additional clarification and/or further detail of the site plan as determined necessary by either the Executive Director or the Area Plan Commission;
3. PUD zoning designation ordinance
- a. A written PUD Ordinance shall be adopted by reference, attached as an exhibit to the preliminary plan submittal, and made part of the PUD Zoning Designation Ordinance;
 - b. A legal metes and bounds description of the entire parcel
 - c. Incorporate the elements in sub-section Written Description of District, into the PUD Ordinance to create specific development or use standards that shall apply to the specific sections of phases. These standards may include, but are not necessarily be limited to permitted uses, prohibited uses, maximum or minimum densities of dwelling units, lot areas, floor areas, building setback lines, building separations, yard areas, structure heights, open space, preservation of natural geological features or plantings, signage, parking, landscaping, design standards, phasing or other standards or conditions deemed appropriate by the Area Plan Commission or appropriate legislative body;

- d. Other restrictions may be required by the Area Plan Commission and appropriate legislative body including, without limitations, one (1) or more or all of those basic design requirements set forth in this Section in order to carry out the intent and purpose of this Chapter.
 4. Establish specific or tentative schedule for phasing the development of the various sections of the PUD.
 5. The final landscape plan with specific location of all plant material, specifying size and species.
 6. The PUD Zoning Designation Ordinance, adopted by reference, attached as an exhibit to the submittal and statement that the master plan is in compliance with the adopted PUD Zoning Designation Ordinance.
 7. A statement placed on the plat indicating that the operation and maintenance of designated common areas, common facilities, common buildings and open spaces shall be under the control of a homeowners association in accordance with the laws of White County governing such associations as provided for in the Application and Approval Process in the Subdivision Control Ordinance.
 8. Construction Activities plan indicating how construction activity will be controlled by addressing contractor ingress/egress, construction parking, maintenance of traffic plan, and street cleaning.
 9. All streets shall be located on the plan. The streets must be placed within a Right of Way (ROW) and shall be accompanied by plans and cross sections.
 10. Finalized copy of covenants, if any, to govern the use and maintenance of the development and ensure the continued observance of the provisions of the PUD.
- C. Final plan review procedures

The applicant may submit for a review meeting by the Area Plan Commission to ensure that the final plan is consistent with the preliminary plan.

1. Procedure for review – Area Plan Commission

a. Public Hearing

The final plan and supporting data shall be filed with Executive Director and forwarded to the Area Plan Commission for determination whether the final plan is in conformity with these regulations and in agreement with the approved concept plan.

b. PUD Committee Recommendation

The PUD Committee shall review the Final PUD and make a recommendation to the Area Plan Commission

c. Area Plan Commission action

Within thirty (30) days of the date the item first appears on the Area Plan Commission agenda, the Area Plan Commission shall vote to recommend approval or denial, or approval with conditions of the PUD final plan by a simple majority of those Area Plan Commission members present and voting.

2. Written Findings of Fact

The Area Plan Commission with regard to an application for a PUD final plan must set forth specific written report of determination on each standard.

5.4 FINAL PLAN APPROVAL NOT ACCEPTANCE OF DEDICATION OFFERS

Approval of a PUD final plan does not constitute acceptance by the appropriate legislative body of the offer of dedication of any streets, utilities, sidewalks, parks or other public facilities shown on the plan. However, the appropriate legislative body may accept any such offer of dedication by resolution and may delay such acceptance until such time that the street department head or his/her designee determines that the public improvements have been completed in a satisfactory manner, and accepted or approved by the appropriate authority. Approval is contingent on the provision of as-built plans that provide a certified engineer's confirmation that the final plans were performed in their entirety.

5.5 FINANCIAL ASSURANCE REQUIREMENTS

The petitioner shall provide financial assurance for the satisfactory installation of all public facilities in the form of bonds or any other assurances as are required in the normal procedures of platting pursuant to the provision of the Application and Approval Process of the White County Subdivision Control Ordinance.

5.6 RECORDING THE FINAL PUD PLAN

All approved plans and any modifications thereof, for any PUD district shall be recorded in the office of the White County Recorder in accordance with the provisions set forth in the Application and Approval Process in the Subdivision Control Ordinance before an Improvement Location Permit or a Building Permit may be issued or any development takes place.

5.7 PROCEDURES FOR PLATTING A PUD

Final Plat approval for any development pursuant to this Section shall be issued in a manner consistent with that of any other plat under the jurisdiction of the Area Plan Commission in compliance with the procedures set forth in the Application and Approval Process of the White County Subdivision Control Ordinance and with any additional requirements or commitments entered into in connection with the approval of the final plan pursuant to this Section.

5.8 FAILURE TO INITIATE CONSTRUCTION AFTER FINAL PUD PLAN APPROVAL

5.8.1 Invalid projects

No approval of a PUD final plan shall be valid for a period longer than two (2) years from the date of approval unless within such period an Improvement Location Permit or a Building Permit is obtained and construction of a building's foundations have

commenced. If the project is determined to be invalid, zoning of the parcel shall revert back to its previous zoning prior to the rezoning to a PUD.

5.8.2 Extensions

The Area Plan Commission may grant a one (1) year extension upon written request of the original applicant if the application submitted is substantially the same as the initially-approved application. At such time as the period of validity of an approved final development plan lapses, the final development plan and all uses, terms and conditions thereof may be declared null and void.

5.8.3 Abandonment

Abandonment shall be deemed to have occurred when no improvements have been made pursuant to the approved PUD final plan for twenty four (24) consecutive months or upon the expiration of two (2) years from the date of approval of the final plan. An amendment may be initiated to the zoning map, as provided by law, so that the land will be zoned into a category or categories that most nearly approximate the prior use or other such zoning category or categories that the legislative body deems appropriate.

5.9 AS-BUILT PLANS REQUIREMENT

Where upon completion of all development, the exact measurements of the location of buildings and structures erected during the development are necessary for public record and shall therefore be recorded. The developer shall submit a copy of the approved Construction Plans (as-built plans), as amended, to the Building Inspector with the exact measurements thereon shown. The Building Inspector, after being satisfied that the measurements are substantially the same as indicated on the originally approved final plan(s), shall approve, date and sign said Construction Plans for the project, which the developer shall then record.

5.10 LIMITATION OF REZONING

Unless the project is abandoned, no amendments to the zoning map concerning PUD final plan district shall be initiated by the Area Plan Commission or the appropriate legislative body before the completion of the development provided that the development is in conformity with the approved PUD final plan and the development is proceeding in accordance with the time requirements imposed therein.

5.11 PROCEEDINGS FOR ENFORCEMENT

In case any building or structure is constructed, reconstructed, altered, repaired, converted, or maintained, or any building, structure, or land is used in violation of this Ordinance or other regulation made under the authority conferred thereby, the appropriate legislative body, in addition to other remedies, may institute any appropriate action or proceedings to: prevent the unlawful construction, reconstruction, alteration, repair, conversion, maintenance, or use; prevent any illegal act, conduct, business, or use in or about the premises; prevent the occupancy of the building, structure, or land; or restrain, correct, or abate the violation.

5.12 FEES

Any person, firm, corporation, or agent, who shall file an application for amendment or application for an appeal, variation, or special use, or for any other certificate or license required under the terms of this Ordinance, shall be charged a fee in accordance with a schedule of fees, as contained within the appropriate legislative body ordinance.

5.13 PENALTIES

Any person, firm or corporation who violates, disobeys, omits, neglects, or refuses to comply with the rules of this Chapter, shall upon conviction, be fined in accordance with Chapter 13, Enforcement. Each day that a violation continues to exist shall constitute a separate offense.

CHAPTER 6 OVERLAY DISTRICTS

6.0 PURPOSE AND INTENT

The purpose of creating Overlay Districts is to provide for development in areas that have a unique nature or needs. Thus, to facilitate the best use of these specific geographic areas, development standards, regulations, special exemptions or requirements are applied to applicable zoning districts above and beyond those developmental standards, regulations, special exemptions or requirements which have been established for the base zoning district.

6.1 ORDINANCE REPEAL

White County Ordinance #02-08-05-01 White County Ordinance For Flood Hazard Areas is hereby repealed by passage of this Ordinance.

6.2 CONSERVATION AND FLOOD PLAIN OVERLAY DISTRICT

The purpose of the Conservation and Flood Plain Overlay (CFO) District is to provide for development within a flood plain or flood hazard area while reducing the potential for: Loss of life and property; health and safety hazards; and the potential for extraordinary public expenditures for flood protection and relief. The boundaries of all CFO Districts shall coincide with those boundaries established by the countywide floodplain maps produced by the Federal Emergency Management Agency (FEMA) for the applicable jurisdiction, as amended from time to time. Specifically, a CFO District is intended to:

- A. Prevent unwise development from increasing flood or drainage hazards to others.
- B. Protect new buildings and major improvements to buildings from flood damage.
- C. Protect human life and health from the hazards of flooding.
- D. Lessen the burden on the taxpayer for flood control projects, repairs to flood damaged public facilities and utilities, and flood rescue and relief operations.
- E. Maintain property values and a stable tax base by minimizing the potential for creating flood blighted areas.
- F. Make federally subsidized flood insurance available for structures and their contents in White County by fulfilling the requirements of the National Flood Insurance Program.
- G. Minimize prolonged business interruptions and loss of employment.

6.2.2 Regulations

Regulations pertaining to the management of the CFO and Floodplain Overlay District are provided for in Appendix E. Appendix E has been constructed to comply with the requirements of the National Flood Insurance Program, the Indiana Department of Natural Resources and the Federal Emergency Management Agency.

6.2.3 District Boundaries

District boundaries are defined by the official maps issued by the Federal Emergency Management Agency or Federal Insurance Administration which pertain to areas of flood hazards and regulatory floodways and any other maps pertaining to Flood Hazard Areas and provided for in Appendix E.

CHAPTER 7

RENEWABLE ENERGY SYSTEMS

WIND AND SOLAR SITING REGULATIONS

7.0 PURPOSE AND INTENT

7.0.1 Purpose

The purposes of this Chapter are to:

- A. Assure that any development and production of wind and solar generated electricity in White County is safe and effective;
- B. Facilitate economic opportunities for local residents; and
- C. Promote the supply of wind and solar clean and renewable energy sources as part of a national effort to reduce reliance on carbon-based energy production.

7.0.2 Intent

It is the intent of the Wind and Solar siting regulations to provide a regulatory scheme for the construction and operation of wind and solar energy projects in White County subject to reasonable restrictions. These regulations are intended to preserve the health, safety and general welfare of the public.

7.1 APPLICABILITY

The provisions of this Chapter are applicable to those districts which allow wind and/or solar energy developments and are intended to govern the siting and development of wind and solar energy projects in a manner compatible with the long-term safety, health and welfare of the community.

7.2 PROHIBITION

No applicant shall construct, operate, or locate a wind or solar energy project within White County without having fully complied with the provisions of this Chapter.

7.3 CONFLICT WITH OTHER REGULATIONS

Nothing in this Chapter is intended to preempt other applicable state and federal laws or regulations, including compliance with all Federal Aviation Administration rules and regulations and shall comply with the notification requirements of the Federal Aviation Administration. Nor are they intended to interfere with, abrogate, or annul any other ordinance, rule, or regulation, statute or other provision of law. In the event that any provision of these regulations imposes restrictions different from any other ordinance, rule, regulation, statute, or provision of law, the provisions that are more restrictive or that impose higher standards shall govern.

7.4 DISTRICT REGULATIONS – WECS

7.4.1 Location

Commercial, Non-commercial and Micro WECS will be permitted, or not permitted, in various districts as prescribed by the Official Schedule of Uses (Appendix A).

7.4.2 Height

A. Non-Commercial WECS or Meteorological Towers

Any Non-commercial WECS Turbine or Meteorological Tower greater than two hundred (200) feet in height shall require a variance approval from the Board of Zoning Appeals.

B. Commercial WECS or Operational Support Meteorological Towers

For Commercial WECS Turbines and Operational Support Meteorological Towers there are no limitations on height, except those height limitations imposed by Federal Aviation Administration rules and regulations.

C. Micro WECS

No Micro WECS Turbine shall exceed sixty (60) feet in height.

7.5 Setback Requirements

7.5.1 Minimum setback distances for COMMERCIAL WECS TOWERS

Distance from the vertical centerline of the WECS Tower to...	Minimum Setback Distance
Any Participating Landowner's property line	<p>The full length of one blade of the WECS Turbine being placed on such property.</p> <p>(i) The setback requirement is waived if the affected adjoining landowners sharing the common property line are Participating Landowners.</p> <p>(ii) A WECS Turbine may be placed up to the property line, if a fully executed and recorded written waiver agreement is secured from the affected adjoining Non-Participating Landowner.</p>
Any Non-Participating Landowner's property line	1.1 times the total height of the WECS Turbine when the blade is at its highest point (This requirement may be waived subject to the written consent of the owner of an affected Non-Participating Landowner)
The nearest point on the outer wall of a residential dwelling	Two (2) times the total height of the WECS Turbine when the blade is at its highest point (This requirement may be waived subject to the written consent of the Landowner of an affected property, whether Participating or Non-Participating) ¹

¹ The setback for residential dwellings shall be reciprocal in that no residential dwelling shall be constructed within one thousand (1,000) feet of a COMMERCIAL WECS Turbine, measured from the vertical centerline of the WECS Tower to the nearest point on any outer wall of the dwelling.

Distance from the vertical centerline of the WECS Tower to...	Minimum Setback Distance
Any property line of a Participating Landowner	The length of one (1) blade of the WECS Turbine. This setback requirement is waived if the affected joining landowner sharing the common property line is a Participating Landowner
Any property line of a Non-Participating Landowner, that is not the property line of any undeveloped land that is zoned or platted for residential use	One and one tenth (1.1) times the total height of the WECS Turbine when the blade tip is at its highest point. A WECS Turbine may be placed up to the property line if a fully executed and recorded written waiver agreement is secured from the affected adjoining Non-Participating Landowner.
The property line of any undeveloped land that is zoned or platted for residential use	Two (2) times the total height of the WECS Turbine when the blade is at its highest point
The centerline of any public road right-of-way	One and one tenth (1.1) times the total height of the WECS Turbine when the blade tip is at its highest point ²
The centerline of any railroad or public utility easement or rights-of-way	One and one tenth (1.1) times the total height of the WECS Turbine when the blade tip is at its highest point
The closest boundary point on public conservation lands	Seven hundred and fifty (750) feet
The closest boundary point of a wetlands, as defined by the U.S. Army Corps of Engineers	As determined by a permit obtained from the Army Corps of Engineers
The Tippecanoe River shoreline as delineated on the County GIS mapping system	One-half (1/2) mile
A property line of a State Park	One (1) mile
The incorporated limits of a municipality or GIS boundary line of Idaville and Buffalo	One (1) mile. This limitation may be waived, in part or in full, with the written consent of the effected legislative body

² The setback shall be measured from a future public rights-of-way width if a planned public road improvement or expansion is known at the time of application.

Distance from the vertical centerline of the WECS Tower to...	Minimum Setback Distance
The nearest edge of any of the rights-of-way for any utility transmission or distribution line	One and two tenths (1.2) times the total height of the WECS Turbine when the blade tip is at its highest point
The centerline of any runway located on a public use airport, private use airport or municipal airport	Five (5) miles for the White County Airport; All other airports, one and one tenth (1.1) times the total height of the WECS Turbine when the blade is at its highest point

7.5.2 Commercial WECS Power Collection and Transmission System

A. WECS substation

For all Substations, setbacks from property lines are waived if the affected adjoining landowners sharing the common property line are all Participating Landowners.

B. Poles

For all poles carrying overhead wiring connecting Commercial WECS Towers to a Substation for connection to a utility's electric transmission line, there are no setback requirements from property lines as long as the poles are located within a recorded easement for such purpose.

7.5.3 Minimum Setback Distances for NON-COMMERCIAL and MICRO WECS TOWERS

Distance from...	Minimum Setback Distance
Any property line as measured from the vertical centerline of the WECS Tower	One and one tenth (1.1) times the total height of the WECS Turbine when the blade tip is at its highest point, provided that the distance is no less than the required yard setback prescribed for that district
A residential dwelling as measured from the vertical centerline of the WECS Tower to the nearest point on the outer wall surface of the residential dwelling	One and one tenth (1.1) times the total height of the WECS Turbine when the blade tip is at its highest point
A public road right-of-way as measured from the vertical centerline of the WECS Tower to the closest edge of the right-of-way	One and one tenth (1.1) times the total height of the WECS Turbine when the blade tip is at its highest point, provided that the distance is no less the required yard setback prescribed for that district ³
Other rights-of-way, such as railroads and public utility easements as measured from the vertical centerline of the WECS Tower to the closest edge of the right-of-way	One and one tenth (1.1) times the total height of the WECS Turbine when the blade tip is at its highest point, provided that the distance is no less than the required yard setback prescribed for that district
Public conservation lands as measured from the vertical centerline of the WECS Tower to the nearest point of the public conservation land in question	Seven hundred and fifty (750) feet
Wetlands, as defined by the U.S. Army Corps of Engineers, as measured from the vertical centerline of the WECS Tower to the nearest point of the subject wetland	As determined by a permit obtained from the Army Corps of Engineers
The Tippecanoe River as measured from the vertical centerline of the WECS Tower to the River shoreline as delineated on the County GIS mapping system	One half (1/2) of a mile
Above-ground electric transmission lines as measured from the vertical centerline of the WECS Tower	One and one tenth (1.1) times the total height of the WECS Turbine when the blade tip is at its highest point

³ The setback shall be measured from the closest boundary of any future public rights-of-way if a planned public road improvement or expansion is known at the time of application.

7.5.4 Horizontal extension for Non-commercial and Micro WECS

The furthest horizontal extension (including guy wires) shall not extend into a required setback of the applicable zoning district or be closer than twelve (12) feet to any primary structure or public right-of-way easement for any above-ground telephone, electric transmission or distribution line.

7.5.5 Minimum setback distances for all Meteorological Towers

Distance from a...	Minimum Setback Distance
Property line as measured from the vertical centerline of the Meteorological Tower	One and one tenth (1.1) times the total height of the Meteorological Tower, provided that the distance is no less than the required yard setback (i) The setback requirement is waived if the affected adjoining landowners sharing a common property line are Participating Landowners
Residential dwelling as measured from the vertical centerline of the Meteorological Tower to the nearest point on the outer wall surface of the residential dwelling	One and one tenth (1.1) times the total height of the Meteorological Tower
Public road right-of-way as measured from the vertical centerline of the Meteorological Tower to the closest edge of the right-of-way	One and one tenth (1.1) times the total height of the Meteorological Tower, provided that the distance is no less than the required yard setback ⁴
Other rights-of-way, such as railroads and public utility easements, as measured from the vertical centerline of the Meteorological Tower to the closest edge of the right-of-way	One and one tenth (1.1) times the total height of the Meteorological Tower, provided that the distance is no less than the required yard setback

7.5.6 Horizontal extension for all Meteorological Towers

The furthest horizontal extension for any meteorological tower (including guy wires) shall not extend into a required setback of the applicable zoning district or be closer than twelve (12) feet to any primary structure, or public right-of-way easement for any above-ground telephone, electric transmission or distribution lines.

⁴ The setback shall be measured from the closest boundary of any future public rights-of-way if a planned public road improvement or expansion is known at the time of application.

7.6 SAFETY DESIGN AND INSTALLATION STANDARDS

7.6.1 Equipment type

A. Turbines

All turbines shall be constructed of commercially available equipment.

B. Meteorological Towers

All Meteorological Towers may be guyed.

C. Experimental, or proto-type equipment

Experimental or proto-type equipment still in testing which does not fully comply with industry standards, may be approved by the Board of Zoning Appeals per the variance process established by this Ordinance.

7.6.2 Industry standards and other regulations

All WECS shall conform to applicable industry standards, as well as all local, state and federal regulations. An applicant shall submit certificate(s) of design compliance that wind turbine manufacturers have obtained from Underwriters Laboratories, Det Norske Veritas, Germanischer Lloyd Wind Energie, or an equivalent third party.

7.6.3 Controls and brakes

A. Braking system

All WECS Turbines shall be equipped with a redundant braking system. This includes both aerodynamic over speed controls (including variable pitch, tip, and other similar systems) and mechanical brakes. Stall regulation shall not be considered a sufficient braking system for over speed protection.

B. Operation mode

All mechanical brakes shall be operated in a fail-safe mode.

7.6.4 Electrical components

A. Standards

All electrical components of all WECS shall conform to applicable local, state and national codes, and any relevant national and international standards.

B. Collection cables

All electrical collection cables between each WECS Turbine shall be located underground wherever possible.

C. Transmission lines

All transmission lines that are buried should be at a depth consistent with or greater than local utility and telecommunication underground lines standards or as negotiated with the land owner or the land owner's designee until the same reach the property line or a substation adjacent to the property line.

7.6.5 Color and Finish

In addition to all applicable Federal Aviation Administration requirements, the following shall also apply:

A. WECS turbines

All WECS turbines shall be white, grey, or another non-obtrusive color.

B. Finishes

Finishes shall be matte or non-reflective.

C. Exceptions

Exception may be made for all Meteorological Towers where concerns exist relative to aerial spray applicators.

7.6.6 Warnings

A. Commercial WECS

The following notices shall be posted for all Commercial WECS

1. A sign or signs be posted on the pad-mounted transformer and the Substation(s) warning of high voltage
2. Private roads providing access to Commercial WECS shall have posted an Emergency-911 address road sign

B. Guy wires and anchor points

For all guyed towers, one of the following warning mechanisms shall be used for each anchor point

1. Visible or reflective objects

Visible and reflective objects, such as flags, plastic sleeves, reflectors, or tape placed on the anchor points of guy wires and along the innermost guy wires up to eight (8) feet above the ground

2. Visible Fencing

Visible fencing not less than four (4) feet in height installed around anchor points of guy wires.

C. Non-commercial WECS and Micro WECS

The following notices shall be clearly visible on all Non-commercial and Micro WECS Towers and accessory facilities;

1. "No Trespassing" signs shall be attached to any perimeter fence.

2. "Danger" signs shall be posted at the height of five (5) feet on WECS Towers and accessory structures.
3. A sign shall be posted on the WECS Tower showing an emergency telephone number.
4. The manual electrical and/or overspeed shutdown disconnect switch(es) shall be clearly labeled.

D. Meteorological Towers

Consideration shall be given to painting of the aviation warnings as required by the Federal Aviation Administration on all Meteorological Towers.

7.6.7 Climb Prevention

All Commercial WECS Tower designs shall include features to deter climbing or be protected by anti-climbing devices such as:

- A. Fences with locking portals at least six (6) feet in height; or
- B. Anti-climbing devices fifteen (15) feet vertically from the base of the WECS Tower; or
- C. Locked WECS Tower doors.

7.6.8 Blade Clearance

The minimum distance between the ground and any protruding blade utilized on a Commercial WECS Turbines shall be twenty-five (25) feet as measured at the lowest point of the arc of the blades. The minimum distance between the ground and any protruding blade utilized on all Non-commercial or Micro WECS Turbines shall be a minimum of fifteen (15) feet as measured at the lowest point of the arc of the blade, provided the rotor blade does not exceed 20 feet in diameter. In either instance, the minimum distance shall be increased as necessary to provide for vehicle clearance in locations where over-sized vehicles might travel.

7.6.9 Lighting

- A. Intensity and frequency

All lighting, including lighting intensity and frequency of strobe, shall adhere to but not exceed requirements established by Federal Aviation Administration permits and regulations.

- B. Shielding

Except with respect to lighting required by the Federal Aviation Administration, lighting may require shielding so that no glare extends substantially beyond any WECS Turbine.

7.6.10 Materials handling, storage and disposal

A. Solid Wastes

All solid wastes whether generated from supplies, equipment, parts, packaging, operation or maintenance of the WECS, including old parts and equipment related to the construction, operation and/or maintenance of the WECS shall be removed from the site promptly and disposed of in accordance with all federal, state, and local laws.

B. Hazardous materials

All hazardous materials or waste related to the construction, operation and/or maintenance of any WECS shall be handled, stored, transported and disposed of in accordance with all applicable local, state and federal laws.

7.7 OTHER APPLICABLE STANDARDS

7.7.1 Guyed wire anchors

No guyed wire anchors shall be allowed within any required public road right-of-way setback.

7.7.2 Sewer and water

All facilities or structures that are part of the WECS Project shall comply with the existing septic and well regulations as required by the White County Health Department and/or the State of Indiana Department of Public Health.

7.7.3 Noise and vibration

The noise level of the wind power device associated with a Non-commercial WECS shall be no greater than an average sound level of fifty (50) A-weighted decibels as modeled at the closest outer wall of the nearest principal structure on the subject lot or on an abutting lot if closer to the principal structure on that lot . All other noise and vibration levels shall be in compliance with all county, state and federal regulations.

7.7.4 Utility interconnection

The WECS, if interconnected to a utility system, shall meet the requirements for interconnection and operate as prescribed by the applicable regulations of the electrical utility, as amended from time to time.

7.7.5 Signage

All signs pertaining to a WECS Project must comply with Chapter 10, Sign Standards, with the following exceptions.

A. Surface area

No sign shall exceed sixteen (16) square feet in surface area.

B. Height

No sign shall exceed eight (8) feet in height.

C. Manufacturers or owners company name and/or logo

The manufacturers or owner's company name and/or logo may be placed upon the compartment containing the electrical equipment.

D. Other signs and logos

No other signs or logos shall be placed or painted on any structure or facility that is part of the WECS Project.

7.7.6 Feeder lines

Feeder lines installed as part of any WECS project shall not be considered an essential service. To wit, all communications and feeder lines installed as part of any WECS shall be buried underground wherever possible.

7.7.7 Other appurtenances

No appurtenances other than those associated with the WECS construction, operations, maintenance, decommissioning/removal, and permit requirements shall be connected to any WECS Tower except with express, written permission by the Board of Zoning Appeals.

7.8 OPERATION AND MAINTENANCE

7.8.1 Physical modifications

In general, any physical modification to any WECS that alters the mechanical load, mechanical load path, or major electrical components shall require re-certification. Like-kind replacements shall not require re-certification. Therefore, prior to making any physical modification, the owner or operator shall confer with the Building Inspection Department and Area Plan Staff to determine whether the physical modification requires re-certification.

7.8.2 Interference

Prior to construction, a communications study to minimize interference with public or public serving utility microwave transmissions shall be completed. If necessary, the applicant, owner and/or operator shall mitigate interference with electromagnetic communications, such as radio, telephone, microwaves, or television signals caused by any WECS. In addition, the applicant, owner, and/or operator shall comply with the following:

A. Pre-construction

The applicant shall complete a communications study prior to construction so as to minimize interference with any public or public serving utility microwave transmissions.

B. Post-construction

If, after construction of the WECS, the owner or operator receives a written complaint related to interference with the broadcast of residential television,

telecommunication, communication or microwave transmissions, the WECS owner or operator shall take reasonable steps to mitigate said interference. Interference with private telecommunications systems such as GPS shall be between the company and the complainant.

C. Failure to remedy a complaint

If an agreement to remedy a known interference is not reached within ninety (90) days, appropriate action will be taken, which may result in requiring the WECS to become inactive. This does not apply to interference with private telecommunications systems.

7.8.3 Declaration of public nuisance

Any WECS thereof declared to be unsafe by the White County Area Plan Executive Director or Building Inspector by reason of inadequate maintenance, dilapidation, obsolescence, fire hazard, damage or abandonment is hereby declared to be a public nuisance and shall be abated by repair, rehabilitation, demolition or removal in accordance with the approved Decommissioning Plan.

7.9 DECOMMISSIONING PLAN

Prior to receiving an Improvement Location Permit and Building Permit under this Ordinance, the Board of County Commissioners and the applicant, owner and/or operator shall formulate a decommissioning plan outlining the anticipated means and cost of removing a Commercial WECS project at the end of its serviceable life or upon becoming a discontinued or abandoned use to ensure that the Commercial WECS project is properly decommissioned.

7.9.1 Content

A decommissioning plan shall include, at a minimum, language to the following:

A. Assurance

Written assurance that the Commercial WECS project will be properly decommissioned upon the project life or in the event that the WECS Project is abandoned.

B. Cost estimates

The applicant shall provide a contractor cost estimate for demolition and removal of the WECS project. The cost estimates shall be made by a competent party: such as a professional engineer, a contractor capable of decommissioning or a person with suitable expertise or experience with decommissioning WECS projects.

C. Financial assurance

Applicant will provide financial assurance in an amount at least equal to said demolition and removal contractor cost estimate, through the use of a bond, letter of credit or other security acceptable to the County, for the cost of decommissioning each WECS Project and related improvements constructed under the permit. Said security will be released when each WECS Project is

properly decommissioned as determined by the White County Board of Commissioners.

D. Abandonment by the owner or operator

In the event of abandonment by the owner or operator, the applicant will provide an affidavit to the White County Board of Commissioners representing that all easements and/or leases for WECS Projects shall contain terms that provide financial assurances, including access to the salvage value of the equipment, for the property owners to ensure that the WECS Projects are properly decommissioned within one (1) year of expiration or earlier termination of the WECS Project.

7.9.2 Discontinuation and abandonment

A. Discontinuation

Any WECS or WECS Turbine shall be considered a discontinued use after one (1) year without energy production, unless a plan is developed and submitted to the White County Area Plan Department outlining the steps and schedule for returning the WECS or WECS Project to service.

7.9.3 Removal

An applicant's obligations shall include removal of all physical material pertaining to the project improvements to no less than a depth of four (4) feet below ground level within three hundred sixty-five (365) days of the discontinuation or abandonment of the WECS or WECS Project, and restoration of the project area to as near as practicable the condition of the site immediately before construction of such improvements. Removal obligations shall be completed by the owner or by White County at the owner's expense.

7.9.4 Written notices

Prior to implementation of the existing procedures for the resolution of such default(s), the appropriate County body shall first provide written notice to the owner and/or operator, setting forth the alleged default(s). Such written notice shall provide the owner and/or operator a reasonable time period not to exceed sixty (60) days, for good faith negotiations to resolve the alleged default(s).

7.9.5 Costs incurred by the County

If the County removes a WECS Turbine and appurtenant facilities, it may sell the salvage to defray the costs of removal. By approval, the permittee or grantor grants a license to White County to enter the property to remove a WECS Turbine and appurtenant facilities pursuant to the terms of an approved decommissioning plan.

7.10 LIABILITY INSURANCE – LIABILITY

The owner or operator of any WECS shall maintain a current general liability policy covering bodily injury and property damage and may be required to name White County as an additional insured with dollar amount limits per occurrence, in the aggregate, and a deductible, which is suitable to the County.

A project developer and project owner are liable for all damages to waterways, drainage ditches, filed tiles, or other drainage related infrastructure caused by the construction, installation or maintenance of any WECS and related improvements constructed under the permit and is responsible for completely repairing, to near original condition, so as to not impede the natural flow of water. All repairs must be completed within a reasonable period of time and to the satisfaction of the unit and as stated in an applicable lease or other agreement with a landowner subject to applicable federal, state and local drainage laws and regulations.

7.11 APPLICATION PROCEDURES

Permits and variances shall be applied for and reviewed under the procedures established by this Ordinance and shall include the following information:

7.11.1 Applications for All Wind Energy Conversion Systems Projects

An application for all WECS projects shall include the following information:

A. Contact information of project applicant

The name(s), address(es), and phone number(s) of the applicant(s), as well as a description of the applicant's business structure and overall role in the proposed project.

B. Contact information of project owner(s)

The name(s), address(es), and phone number(s) of the owner(s), as well as a description of the owner's business structure and overall role in the proposed project, and including documentation of land ownership or legal control of the property on which the WECS project is proposed to be located. The Area Plan Staff shall be informed of any changes in ownership.

C. Contact information of the project developer(s)

The name(s), address(es), and phone number(s) of the developer(s), as well as a description of the developer's business structure and overall role in the proposed project.

D. Contact information of the project developer(s)

The name(s), address(es), and phone number(s) of the operator(s), as well as a description of the operator's business structure and overall role in the proposed project.

E. Legal description

The legal description, address, and general location of the project.

F. Project description

A WECS Project description, including to the extent possible, information on each wind turbine proposed, including:

1. Number of turbines;
2. Type;

3. Name plate generating capacity;
 4. Tower height;
 5. Rotor diameter;
 6. Total height;
 7. Anchor base;
 8. The means of interconnecting with the electrical grid;
 9. The potential equipment manufacturer(s); and
 10. All related accessory structures
- G. A site layout plan
- A site layout plan, drawn at an appropriate scale, showing distances pertaining to all applicable setback requirements and certified by a registered land surveyor.
- H. Engineering certification
- For all WECS, the manufacturer's engineer or another qualified registered professional engineer shall certify, as part of the Improvement Location permit application, that the foundation and tower design of the WECS is within accepted professional standards, given local soil and climate conditions. An engineering analysis of the WECS Tower showing compliance with the applicable regulations and certified by a licensed professional engineer shall also be submitted. The analysis shall be accompanied by standard drawings of the WECS Tower, its base, and its footings.
- I. Proof correspondence and cooperation with wildlife agencies
- For the purposes of preventing harm to migratory birds and in compliance with the Migratory Bird Treaty Act, the applicant shall provide written documentation that he or she is in direct correspondence and cooperation with the U.S. Fish and Wildlife Service and the Indiana Department of Natural Resources.
- J. Certification that the project owner/developer has used industry standard computer modeling for each Wind Power Device to estimate the amount of shadow flicker anticipated to be caused by the wind power device and, that such modeling indicates that no wind power device will expose any dwelling on a Non-Participating Landowner's property to more than thirty (30) hours per year of shadow flicker. (The thirty (30) hours per year shadow flicker limitation may be waived subject to the written consent of the owner of each affected Non-Participating Landowner).
- K. Certification and description of the WECS Turbine light mitigation technology to be used on the project. The light mitigation technology requirement shall be waived upon written demonstration by the project owner or developer that such technology components are not readily available, that the FAA denies approval of such technology use or if such technology is not economically feasible.
- L. Any other item reasonably requested by the Area Plan Staff.

7.11.2 Applications for Non-commercial Wind Energy Conversion Systems Projects

In addition to the application requirements listed in 7.11.1, Applications for All Wind Energy Conversion Systems Projects, applications for Non-commercial WECS shall also include the following information:

A. Demonstration of energy need

The primary purpose of the production of energy from a Non-Commercial WECS project shall be to serve the energy needs of that tract. The applicant(s) shall demonstrate how much energy is needed and how the proposed size and number of the WECS Turbines fulfills this need. Net-metering may be allowed, but shall not be the primary intent of the WECS project.

B. Statement of Federal Aviation Administration compliance

The applicant shall provide a statement of compliance to all applicable Federal Aviation Administration rules and regulations, including any necessary approvals for installations within close proximity to an airport.

C. Utility notification

No Non-commercial WECS shall be installed until evidence has been given that the local utility company has been informed of the customer's intent to install an interconnected customer-owned generator. Off-grid systems shall be exempt from this requirement.

D. Compliance with National Electrical Code

A line drawing of the electrical components in sufficient detail to allow for a determination that the manner of installation conforms to the National Electrical Code. This information is frequently supplied by the manufacturer.

7.11.3 Applications for Commercial Wind Energy Conversion Systems Projects

In addition to the application requirements listed in 7.11.1, applications for all Commercial WECS Projects shall also include the following information:

A. A preliminary site layout plan

In place of the site layout plan described in 7.11.1(F), applications for all Commercial WECS Projects shall include a preliminary site layout plan with distances drawn to an appropriate scale illustrating the following;

1. Property lines, including identification of adjoining properties;
2. The latitude and longitude of each individual WECS Turbine, along with individual identification of each WECS Turbine;
3. Dimensional representation of the structural components of the WECS Turbine construction including the base and footings;
4. WECS Turbine access roads;
5. Substations;
6. Electrical cabling;

7. Ancillary equipment;
 8. Primary structures within one quarter (1/4) mile of all proposed WECS Towers;
 9. Distances from each individual WECS Tower to each setback requirement;
 10. Location of all public roads which abut, or traverse the proposed site
 11. The location of all above-ground utility lines within a distance of two (2) times the height of any proposed WECS Turbine;
 12. The location of any historic or heritage sites as recognized by the Division of Historic Preservation and Archeology of the Indiana Department of Natural Resources, within one (1) mile of a proposed WECS Tower; and
 13. The location of any wetlands based upon a delineation plan prepared in accordance with the applicable U.S. Army Corps of Engineers requirements and guidelines, within one (1) mile of a proposed WECS Tower.
- B. Topographic map
- A USGS topographical map, or map with similar data, of the property and the surrounding area, including any other WECS Tower within a ten (10) rotor distance, but no less than a one quarter (1/4) mile radius, from the proposed project site, with contours at not more than five (5) foot intervals.
- C. Noise profile
- The project owner shall provide certification that the wind power device will operate in a manner such that the sound attributable to the wind power device will not exceed an hourly average sound level of fifty (50) A-weighted decibels as modeled at the outer wall of an affected dwelling. (This requirement may be waived subject to the written consent of the owner of an affected property)
- D. A Wind Power Project developer must provide certification that each wind power device will minimize and mitigate impacts to;
1. Television signals;
 2. Microwave signals;
 3. Agricultural global positioning systems;
 4. Military defense radar;
 5. Radio reception; and;
 6. Weather and doppler radar.
- E. Location of all known WECS Towers within one (1) mile of the WECS Project Area, including a description of the potential impacts on said WECS Towers.
- F. Copy of the WECS Project Communications Study

7.11.4 Applications for all Meteorological Towers

Applications for all Meteorological Towers shall include the following information:

- A. A copy of the agreement where the landowner has authorized the placement of a Meteorological Tower on their property.
- B. Preliminary site layout plan
 - A preliminary site layout plan with distances drawn to an appropriate scale including the following:
 - 1. Property lines, including identification of adjoining properties;
 - 2. The latitude and longitude of each individual Meteorological Tower;
 - 3. Dimensional representation of the structural components of the tower construction, including the base and footings;
 - 4. Electrical cabling;
 - 5. Ancillary equipment;
 - 6. Required setback lines;
 - 7. Location of all public roads which abut, or traverse the proposed site;
 - 8. The location of all above-ground utility lines within a distance of 2 times the height of any proposed tower;
 - 9. The location of all underground utility lines; and
 - 10. Any other items reasonably requested by the Area Plan Department.
- C. Variance approval if any Non-commercial Meteorological Tower is greater than two hundred (200) feet in height.

7.11.5 Aggregated project applications

Aggregated projects may jointly submit a single application and be reviewed under joint proceedings, including notices, hearing, and reviews and as appropriate, approvals.

7.11.6 Fees

- A. Commercial, Non-commercial and Micro WECS Projects, Meteorological Towers, and any accessory buildings:
 - As prescribed by the County's Official Schedule of Fees.
- B. Aggregated WECS Projects
 - Applications will be assessed fees for each construction phase within a single WECS Project, as prescribed by the County's Official Fee Schedule.

7.11.7 Permits

A. Before any Improvement Location or Building Permit may be issued for any Commercial, Non-commercial or Micro WECS Turbines or for any WECS project accessory structure, the following must be satisfied:

1. Completion of all application requirements as provided for in this Chapter or a required elsewhere in this Ordinance;
2. A copy of all Memorandum of Agreements signed by Participating Landowners authorizing the placement of the identified WECS Turbines on the landowner's property and/or adjoining properties shall be provided; and,
3. A fully executed setback waiver agreement signed by a Non-participating Landowners for adjoining properties shall be provided, when applicable;

B. Aggregated WECS Projects

For aggregated WECS Projects, Improvement Location Permits and, when applicable, Building Permits will be issued individually for each WECS Turbine.

C. Meteorological Tower

Each meteorological tower requires issuance of an Improvement Location Permit prior to construction. Building permits are not required for meteorological towers. An ILP may be issued upon completion of all application requirements as provided for in this Chapter or as required elsewhere in this Ordinance.

7.12 PRE-CONSTRUCTION REQUIREMENTS

Prior to the issuance of any Improvement Location Permit or Building Permit, the following shall be submitted to and reviewed by the Area Plan Staff, who shall certify that the following are in compliance with all applicable regulations:

7.12.1 FAA permit application

A Federal Aviation Administration permit application and/or project approval notification.

7.12.2 Decommissioning plan

A fully executed decommissioning plan approved by the County Commissioners or proof from that body that a waiver from this requirement has been granted.

7.12.3 Economic Development, Drainage, and Road Use and Maintenance Agreements

A fully executed Economic Development Agreement, a Drainage Agreement and a fully executed Road Use and Maintenance Agreement approved by the County Commissioners a copy of which shall be provided to the Area Plan Staff. The Drainage Agreement must prescribe or reference provisions to address crop and field tile damages or proof from that body that a waiver from one or more of these requirements has been granted.

7.12.4 Erosion control plan

An erosion control plan developed in consultation with the Natural Resources Conservation Services (NRCS), and any storm water quality management plan adopted by the applicable jurisdiction.

7.12.5 Utility plan

A utility plan drawn to the same scale as the site layout plan illustrating the location of all underground utility lines associated with the total WECS Project.

7.12.6 Avoidance and mitigation of damages to public infrastructure

In addition to complying with the approved Road Use and Maintenance Agreement, an applicant, owner, developer or operator proposing to use any county road(s), for the purpose of transporting any component of a Commercial WECS Project and/or equipment for construction, operation or maintenance of a Commercial WECS Project, shall comply with the following pre-construction requirements.

A. Identification of roads and services

Provide a written delineation of all routes, roads and services to be used for construction and maintenance purposes. If the delineation includes a public road, written approval from the White County Highway Superintendent shall be provided.

B. Pre-construction survey

The applicant shall conduct a pre-construction baseline survey acceptable to the White County Highway Superintendent to determine existing road conditions for assessing potential future damage. The survey shall include photographs, or video, or a combination thereof, and a written agreement to document the condition of the public facility. Upon execution, such agreement shall be provided to the Area Plan Staff.

7.13 CONSTRUCTION REQUIREMENTS

During construction, the applicant shall demonstrate that the following requirements are being met:

7.13.1 Dust control

Reasonable dust control measures shall be required by the County during construction of a Commercial WECS Project.

7.13.2 Drainage

Reasonable storm water best management practices as required by the approved Drainage Plan/Agreement on file with the White County Surveyor.

7.14 POST-CONSTRUCTION REQUIREMENTS

Post-construction, the applicant shall comply with the following provisions:

7.14.1 Road Repairs

Any road damage caused by the construction of project equipment, the installation of the same, or the removal of the same, shall be repaired as per the Road Use and Maintenance Agreement approved by the County Commissioners. The White County Highway Superintendent may choose to require either remediation of road repairs upon completion of the project or is authorized to collect fees for oversized load permits. Further, a corporate surety bond in an amount to be fixed by a professional engineer may be required by the White County Highway Superintendent to insure the County that future repairs are completed to the satisfaction of the unit of local government. The cost of bonding is to be paid by the applicant.

7.14.2 As-Built Plans Requirement

Where upon completion of all development, the exact measurements of the location of utilities and structures erected during the development are necessary for public record and shall therefore be recorded. The applicant, owner, developer or operator shall submit a copy of the Final Construction Plans (as-built plans), as amended, to the Area Plan Department with the exact measurements thereon shown. The Area Plan Department Executive Director, after being satisfied that the measurements are substantially the same as indicated on the originally approved final plan(s), shall approve, date and sign said Construction Plans for the project, which the applicant, owner, developer or operator shall then record.

7.14.3 Change in ownership

It is the responsibility of the owner, developer or operator listed in the application to inform the Area Plan Staff of all changes in ownership and operation during the life of the project, including the sale or transfer of ownership or operation.

7.15 COMMERCIAL, INDIVIDUAL AND SHARED SOLAR ENERGY SYSTEMS ***

7.15.1 Purpose, Persons Liable, Authority, Scope and Exclusions & Exemptions

A. Purpose

This section is established in order to protect the public health, safety and general welfare of the community while accommodating the production and energy objectives associated with solar energy efforts. As such, it is necessary to regulate the use, construction and modification of Individual Solar Energy Systems (ISE), Shared Solar Energy Systems (SSE) and Commercial Solar Energy Systems (CSE). This section works to avoid the adverse impacts of such operations on the community and the area's natural and constructed resources while still accommodating the need for solar energy production.

B. Persons Liable

The property owner and developer have the duty of compliance with the requirements of this Chapter and any other requirements provided for in this Ordinance pertaining to ISE, SSE and CSE developments.

C. Authority

Area Plan Department Staff are hereby vested with the authority to review and approve or deny applications for ISE, SSE and CSE developments as well as for modifications, alterations, upgrades, maintenance (other than routine maintenance) or revisions to these developments under the direction of the Area Plan Executive Director.

D. Scope

Section 7.15 applies to all ISE, SSE and CSE developments as defined in Chapter 14, Definitions. Nothing in this Chapter or Ordinance is intended to preempt other applicable State and/or Federal Laws or regulations pertaining to solar energy development. Where a conflict occurs between this Chapter and any other requirements of the White County Indiana Zoning Control Ordinance, this Chapter shall prevail.

E. Exclusions and Exemptions

A permit is not required for the following:

1. Any ISE or SSE which does not include in excess of one hundred twenty (120) square feet of solar panel face.
2. Any work which constitutes "routine maintenance" of an ISE, SSE or CSE. Routine maintenance includes, but is not limited to, the following:
 - a. repair of ISE, SSE or CSE components and/or system infrastructure; and/or,
 - b. replacement of components and/or infrastructure with those of the same nature and the same physical size and/or power strength; and/or,
 - c. such other maintenance and/or repair work determined to be routine in nature by the Executive Director.

Also excluded from permit requirements are high-tension power lines, electrical transmission towers, transformers, utility owned substations or utility poles used to connect an ISE, SSE or CSE to a utility system's infrastructure.

F. Other

1. ISE, SSE and CSE developments are exempt from the requirements of Chapter 8 Parking and Loading.
2. ISE, SSE and CSE developments shall meet all applicable State, Local and Federal regulatory codes in addition to the requirements of this Ordinance.

3. ISE, SSE and CSE developments shall be constructed to meet or exceed National Electric Safety Codes.

7.16 APPLICATION REQUIREMENTS

For purposes of this section, the term “application” refers to an Improvement Location Permit (ILP) application along with any other documents required by this Ordinance, this Chapter or which are requested by the Area Plan Staff. Unless specifically exempted by this Chapter, no construction or development of an ISE, SSE or CSE may be initiated without first obtaining an ILP from the Staff and, if required, a Building Permit. All structures (except signage) for the proposed developments may be covered by a single application. Signage for the development must satisfy the requirements of this Chapter as well as the standards of Chapter 10 of this Ordinance and are subject to a permit application process separate from that of the ISE, SSE or CSE physical development application.

A. Application Documents – CSE

The following application documents reflect the minimum amount of information which must be provided for a CSE development:

1. An ILP Application along with the associated application filing fee. This application must be signed by the property owner or developer (if signed by the developer, the developer must provide a properly executed lease agreement or notarized letter from the property owner authorizing the proposed development);
2. A Site Plan which satisfies the content requirements of Chapter 12, Section 12.13, Subsection 12.13.5;
3. Scope of Work & Project Identification
 - a. Contact information – The names, addresses and phone number(s) of all applicants, project owner(s), project developer and project operator;
 - b. Legal description and map of the project area;
 - c. Project description including the number of arrays and their configuration, name plate generating capacity, potential equipment manufacturers, means of connecting to the electrical grid and a site layout plan drawn to appropriate scale (site requirements may be delineated on multiple pages);
4. Engineering certification that the foundation is designed within accepted professional standards given local soil and climate conditions
5. A letter from the respective legislative body certifying that an Economic Development Agreement has been approved by said legislative body
6. Presentation of a fully executed Decommissioning Plan approved by the respective legislative body

7. A letter from the respective legislative body that a Road Use and Road Maintenance Agreement has been approved or that a waiver from such has been granted
8. An approval letter or approved permit of development from the Federal Aviation Administration if any part, piece or component of the CSE penetrates navigable airspace as defined by the Federal Aviation Administration's rules, regulations and guidelines;
9. Delineation of compliance to the requirements of Appendix B Bulk Use Standards
10. Delineation of compliance to all developmental standards provided within this Chapter
11. A letter from the County Surveyor that a drainage plan has been approved or requirement waived by the County Drainage Board
12. A vegetation plan in compliance with subsection 7.17 B. 10. of this Chapter
13. Compliance to screening requirements established by subsection 7.17 B. 8. of this Chapter
14. Certification from an independent, industry, design professional or licensed engineer that the proposed development will not create undue glare or reflection so as to create a traffic hazard or cause a nuisance to neighboring properties; this Certification must clearly delineate all steps taken to mitigate such circumstances; and
15. Any other item reasonably requested by the Area Plan Staff.

B. Application Documents – ISE, SSE

The following application documents reflect the minimum amount of information which must be provided for an ISE or SSE development:

1. ILP Application along with the associated application filing fee. This application must be signed by the property owner or developer;
2. Site Plan which satisfies the content requirements of Chapter 12, Section 12.13, Subsection 12.13.5;
3. Letter of Development Approval from the Federal Aviation Administration, if any part, piece or component of an ISE or SSE penetrates navigable airspace as defined by the Federal Aviation Administration's rules, regulations and guidelines. This may come in the form of an aeronautical study approval;
4. Delineation of compliance to the requirements of Appendix B Bulk Use Standards;
5. Delineation of compliance to all developmental standards provided within this Chapter.

7.17 DISTRICT REGULATIONS AND PERFORMANCE STANDARDS

A. Location

1. ISE, SSE and CSE developments will be allowed or not allowed as prescribed by the Official Schedule of Uses (Appendix A). At no time will an ISE, SSE or CSE be allowed in a regulated floodway, flood fringe, regulated wetland or designated conservation or wildlife area without approval from the White County Floodplain Administrator or the Area Plan Executive Director.

B. Size, Height, Setbacks and Other Developmental Standards – CSE

1. All structures shall conform to the standards for principal structures as provided by the Bulk Use Chart (Appendix B) of the zoning district classification for which the development is proposed or to the more restrictive or alternate standard provided for in this Chapter;
2. Utility infrastructure, including support structures for overhead wiring connecting a CSE system to said infrastructure are exempt from the Bulk Use Standards provided for in Appendix B Bulk Use Chart as well as those standards within this Chapter;
3. Any CSE project must have a minimum project area of at least five (5) acres; a project area may consist of multiple parcels, either contiguous or separated only by a road or alley, of which individual parcels may be less than five (5) acres;
4. Any CSE project must have a minimum nameplate capacity of ten (10) megawatts;
5. All solar arrays along with their associated support structures must be ground based not to exceed twenty-five (25) feet in height when the panels are in full tilt and as measured from the surrounding average grade;
6. A CSE system compound may be located no closer than forty (40) feet to the nearest edge of any federal interstate highway, federal highway, state highway or county highway right-of-way; thirty (30) feet to the nearest edge of any collector road right-of-way or ten (10) feet to the nearest edge of any local road right-of-way (these setbacks do not apply to the infrastructure required to distribute electricity to the electrical grid or an associated substation);
7. No perimeter point of a CSE system compound may be closer to a project area property line than fifty (50) feet. This setback requirement may be waived with the written consent of the effected property owners; either Participating or Non-Participating property owners;
8. A CSE system compound may be no closer than one hundred-fifty (150) feet to the nearest point of the outer wall of a dwelling on a non-participating owner's property, subject to installation of a landscape buffer as provided for in subsection 7.17. B. 8 (a) of this Chapter. The landscape buffer requirement of this subsection is hereby waived if the outer edge of the CSE system compound is at least two hundred fifty (250) feet away

from the nearest point of the outer wall of the subject dwelling. The landscape buffer may be waived with the written consent of the non-participating property owner;

9. Screening shall be provided along any segment of a CSE project property line abutting a residential zoning district. In addition, where a residential district lies across the road from a property included in a CSE project area, the portion of the CSE project area property line directly across from the residential district property line, plus an extension of twenty (20) feet along said CSE project area property line, in each direction, shall be screened. These screening requirements are hereby waived should a CSE system compound be no closer than two hundred-fifty feet to the residential district property line. Also, these screening requirements may be waived with the written consent of the affected property owner. Required screening shall meet the following standards:
 - a. Screening may be in the form of a berm or be vegetative in nature (vegetative screenings are preferred) and located between the property line or right-of-way line (whichever is most restrictive) and the security fence (however, no screening shall violate a visual clearance area as provided for in Chapter 3, Subsection 3.07);
 1. If vegetative;
 - a. There shall be a minimum of two (2) rows of planting; the plantings in each row shall be no more than every twenty-five (25) feet apart; the rows shall be separated by no less than six (6) feet and no more than twenty-five (25) feet;
 - b. plantings must reach a minimum height of six (6) feet within two (2) years after planting;
 - c. plantings may be of any variety determined appropriate by the project owner, developer or operator.
 2. If a berm;
 - a. the berm shall have a maximum slope of 3:1;
 - b. be a minimum height of six (6) feet tall
 - c. be a maximum height of ten (10) feet tall; and,
 - d. shall be entirely vegetated with ground cover.

Note: For the purposes of Chapter 7 of this Ordinance, a private road does not include driveways, interior service roads or temporary ingress/egress drives or roads constructed and utilized only for the purpose of a solar energy development or which are intended solely for the purpose of maintaining a solar energy system.

10. Vegetation Plan or Agricultural Plan submission: Each CSE project shall provide a Vegetation Plan or an Agricultural Plan with their application. A Vegetation Plan shall include a perennial vegetated ground cover over all land, including around and under solar panels, not improved with a gravel,

concrete or paved surface. This plan is to be maintained for the life of the project and provide for the use of non-invasive and native or naturalized species. Incorporation of pollinator friendly seed mixes is encouraged but not required. The plan must include the details for site preparation and maintenance practices designed to control invasive species and noxious weeds. An Agricultural Plan shall include a narrative of the type of agricultural activities which are to take place, the area of land to be made available for such activities and the name and contact information of the party(ies) with whom an agricultural agreement has been reached along with a copy of such agreement. Any land area not captured within the Agricultural Plan must meet the Vegetation Plan requirements listed above;

11. A CSE may not produce in excess of an hourly average sound level of fifty (50) A-weighted decibels as modeled at the closest outer wall of a dwelling located on any adjacent, Non-Participating property. The sound level maximum may be waived with the written consent of the Non-Participating property owner;
12. The land area of any CSE system compound shall not be counted toward the lot coverage maximum as provided for in Appendix B Bulk Use Chart for the applicable zoning district of the subject site;
13. All CSE projects must provide security fencing around the outer edge of each CSE system compound in addition to any screening requirements stipulated in Subsection 7.17. B. 8 of this Chapter. Said fencing must provide limited and secured access to prevent entry by unauthorized personnel. Fencing and access gates shall be between six (6) and ten (10) feet tall as measured from the ground grade to the top of the fencing material (post excluded). Note: When a CSE system project area is divided into sections as a result of roads/streets, alleys, easements or similar restricted areas, each CSE system compound within each section is subject to the security fencing requirements of this subsection;
14. All cables between banks of solar panels and the CES solar collection electric substations and operations & maintenance buildings shall be buried underground at a depth of at least thirty-six (36) inches below grade;
15. A CSE system must be designed and constructed to:
 - a. Minimize glare on adjacent properties and roadways; and,
 - b. Not interfere with vehicular or air traffic; no fence or structure may be placed in a visual clearance area as provide for in Chapter 3, Section 3.0.7.
16. A CSE project owner or developer must provide certification that the CSE system will not interfere with:
 - a. Television signals
 - b. Microwave signals
 - c. Agricultural global positioning systems

- d. Military defense radar
 - e. Radio reception; or,
 - f. Weather and doppler radar.
17. A CSE project area may not be located within one-half (1/2) mile of any municipality boundary line or GIS boundary line for Buffalo or Idaville. This limitation may be waived, in part or in full, with the written consent of the effected legislative body;
18. The solar energy project owner or developer must provide a certification of acknowledgement that they are aware and accept liability for all damages to County regulated waterways, drainage, ditches, field tiles or other drainage related infrastructure caused by the construction, installation or maintenance of a solar energy project and such infrastructure must be repaired by the project owner to near original condition so as not to impede the flow of water as it existed in its pre-damaged state. All repairs must be made in a reasonable time and to the satisfaction of the unit and as stated in an applicable lease or other agreement with the landowner subject to applicable federal, state and local drainage laws and regulations;
- C. Size, Height, Setbacks and Other Developmental Standards – ISE, SSE
- 1. All ISE and SSE components will be treated as Accessory Structures for the purposes of applying Bulk Use Chart (Appendix B) standards unless a more restrictive or alternative standard is provided for in this Chapter;
 - 2. Screening shall be provided in accordance with Subsection 7.17 B. 9a) 1. along each section of property line where any solar energy component (excluding roof-top solar installations), is located within twenty (20) feet of a property boundary line abutting a residential district. The screening requirements may be waived or modified by the effected property owner if said effected property owner submits, in writing, agreement to waive or modify the screening requirements
 - 3. Ground Mount Solar Installations;
 - a. All Solar Panels and/or Solar Arrays, as well as the Panel or Arrays underlying framework, shall be a minimum of three (3) feet above ground level as measured from any ground point to the closest point of any solar panel when positioned at the panels most vertical, functioning position; this requirement may be modified or waived by the Executive Director if, in the sole opinion of the Executive Director, the modification or waiver request serves the communities best interest or is unable to be met with minor design alterations; and,
 - b. All ISE/SSE Ground Mount Systems shall be located in a side or rear yard or twenty (20) feet behind a required front setback.

Note: No area of the solar energy system compound shall be counted toward the lot coverage maximum as provided for in Appendix B Bulk Use Chart for the applicable zoning district of the subject site.

4. Roof Top Installations:

Note: Installations using solar shingles designed to serve as a final roof covering are exempt from the requirements of “a” thru “e” below

- a. Solar Panels and/or Solar Arrays shall be separated above the roofing material a minimum of the distance recommended by the panel/array/equipment manufacturer. If the manufacturer does not provide a separation recommendation, then all solar panels and/or solar arrays must be a minimum of four (4) inches and a maximum of eight (8) inches above the roofing material to the bottom of the solar panel;
- b. Solar Panels, Solar Arrays and/or installation framing & bracketry must be mounted so that no edge of any Solar Panel, Solar Array and/or installation framing & bracketry extends beyond the vertical plane of the exterior walls of a building (the eave line);
- c. For roof planes with thirty-three (33) percent or less panel coverage, panels may not extend any closer than eighteen (18) inches to a roof ridge; for roof planes which exceed thirty-three (33) percent coverage, panels may not extend any closer than 36 inches to a roof ridge. For panels mounted on roof tops considered to be flat (two units vertical in twelve units horizontal or less), a thirty-six (36) inch setback from the roof perimeter is required;
- d. Maximum panel coverage for any roof plane is seventy-five (75) percent. For purposes of this Chapter, a roof plane is each continuously flat section of roof whose perimeter is defined by a roof ridge and a series of roof edges or valleys. ;
- e. Excluding a roof top defined as flat under (c) of this subsection, each roof top installation is required to include a minimum of two pathways. Pathway requirements are as follows:
 - i. Pathways must extend from the bottom roof line (roof line closest to the ground) to the ridge line;
 - ii. At least one pathway must be on the roof plane that most closely aligns with the street or driveway;
 - iii. Pathways must be thirty-six (36) inches wide on a single roof plane or, on adjacent roof planes, eighteen (18) inches wide on each side of a roof ridge or valley;
 - iv. At the time of application, the applicant must provide a certification that each pathway will be over areas able to support firefighters and be located in areas without obstructions, including, but not limited to, vent pipes, chimneys, conduit and mechanical equipment.

- f. All solar panel installations require an engineering certification provided at the time of application confirming that the structural integrity of the roof is capable of handling the additional roof load.
 - g. All solar panel installations must include a rapid shutdown disconnect switch. This must be located within two (2) feet of the main electrical meter base for the structure.
5. Tree Style Solar Arrays are allowed only with the approval of the Area Board of Zoning Appeals and the petitioner must demonstrate to the Board that the tree(s) installation will not create a safety hazard or nuisance to any near-by (within one-quarter (1/4) mile) property owner or the community at large.
6. Floating Solar Installations are allowed only with the approval of the Area Board of Zoning Appeals. It is the responsibility of the petitioner to demonstrate compliance with the White County Indiana Zoning Control Ordinance, Appendix E Regulations for Flood Hazard Areas and all Federal, State or Local laws, codes and regulations as well as demonstrate that the installation will not create any community or site safety issues or security vulnerabilities. The property owner or solar energy project developer shall provide written documentation outlining the steps taken to mitigate any potential nuisance factors.
7. For purposes of an SSE designed to provide energy to buildings on abutting properties, the SSE is not required to meet setback or screening requirements from property lines which are common to any properties included within the intended service group.

7.18 COMMERCIAL SOLAR ENERGY SYSTEM'S COLLECTION AND TRANSMISSION SYSTEM

A. CSE System's Substation

For all Substations, setbacks from property lines are waived if the affected adjoining landowners sharing the common property line are all Participating Landowners.

B. Poles

For all poles carrying overhead wiring connecting a CSE system to a Substation for connection to a utility's electric transmission line, there are no setback requirements from property lines as long as the poles are located within a recorded easement for such purpose.

7.19 BATTERY STORAGE FIELDS AND BATTERY STORAGE RETROFITS

All Utility Scale Battery Energy Storage Systems (USBESS), an energy storage system that is capable of storing and releasing more than one (1) megawatt of electrical energy for a minimum of one (1) hour using an AC inverter and DC storage, are subject to regulations under IC 22-14-8, as amended from time to time, and which are required to

follow the National Fire Protection Association (NFPA) 855. standard Those facilities must provide a copy of a permit issued by Homeland Security along with any other applications, documents or submissions required by this section.

All facilities covered under IC 22-14-8, must provide a copy of the applicant's emergency response plan for responding to a fire at or discharge or threatened discharge of environmental contaminants by the USBESS as well as the approved plan for emergency response training.

All Battery Storage Fields or Battery Storage Retrofits, regardless of whether being subject to IC 22-14-8 or not, must meet the requirements provided in this Chapter.

For either a Battery Storage Field or a Battery Storage Retrofit, an Improvement Location Permit Application, a site plan, any other documents associated with the application along with permit fees must be submitted prior to placement or incorporation of Battery Storage units.

Battery Storage units which are incorporated into the original commercial wind or solar energy project application are exempt from the requirements of this Section and are to satisfy the requirements, regulations and development standards demanded by the respective sections and subsections elsewhere in this Chapter.

Unless meeting the exemption listed earlier in this section, all Battery Storage Fields or Battery Storage Retrofit projects must meet the respective requirements, regulations and development standards detailed below as well as any other standards, regulations or requirements applicable elsewhere in this Ordinance:

A. Battery Storage Retrofits

1. Battery Retrofits to an existing wind energy or commercial solar energy system project and designed for placement and use within an approved CSE or WECS project compound must comply with the following:

- a. Submission of an approved, counter signed Economic Development Agreement from the respective legislative body or proof from that body that a waiver from this requirement has been granted;
- b. Submission of an approved, counter signed Decommissioning Plan from the respective legislative body or proof from that body that a waiver from this requirement has been granted;
- c. Submission of an approved, counter signed Road Use and Road Maintenance Agreement from the respective legislative body or proof from that body that a waiver from this requirement has been granted;

- d. A letter from the County Surveyor that a drainage plan has been approved or requirement waived by the County Drainage Board; and,
 - e. Any other item reasonably requested by the Area Plan Staff.
2. Battery Retrofits To Existing Wind Energy or Commercial Solar Energy Systems and designed for placement and use outside an approved project compound must satisfy the same application requirements and district regulations & performance standards as a Battery Storage Field.

B. Battery Storage Field (BSF)

1. The following application documents reflect the minimum amount of information which must be provided for a Battery Storage Field.
 - a. An ILP Application along with the associated application filing fee. This application must be signed by the property owner or developer (if signed by the developer, the developer must provide a properly executed lease agreement or notarized letter from the property owner authorizing the proposed development);
 - b. A Site Plan which satisfies the content requirements of Chapter 12, Section 12.13, Subsection 12.13.5 or as approved by the Executive Director;
 - c. Scope of Work & Project Identification
 - (1) Contact information – The names, addresses and phone number(s) of all applicants, project owner(s), project developer and project operator;
 - (2) Legal description and map of the project area; and,
 - (3) Project description including the number of Battery Housings and their configuration, storage capacity, means of connecting to the electrical grid and a site layout plan drawn to appropriate scale (site

requirements may be delineated on multiple pages);

- d. Submission of an approved, counter signed Economic Development Agreement from the respective legislative body or proof from that body that a waiver from this requirement has been granted;
- e. Submission of an approved, counter signed Decommissioning Plan from the respective legislative body or proof from that body that a waiver from this requirement has been granted;
- f. Submission of an approved, counter signed Road Use and Road Maintenance Agreement from the respective legislative body or proof from that body that a waiver from this requirement has been granted;
- g. Delineation of compliance to the requirements of Appendix B Bulk Use Standards;
- h. Delineation of compliance to all developmental standards provided within this Chapter;
- i. A letter from the County Surveyor that a drainage plan has been approved or requirement waived by the County Drainage Board;
- j. Compliance to screening requirements established by subsection 7.17 B. 8. of this Chapter;
- k. Any other item reasonably requested by the Area Plan Staff.

7.20 DISTRICT REGULATIONS AND PERFORMANCE STANDARDS FOR BATTERY STORAGE FIELDS (BSF)

A. Location

1. Battery Storage Fields will be allowed or not allowed as prescribed by the Official Schedule of Uses (Appendix A). At no time will BSF improvements be allowed in a regulated floodway, flood fringe, regulated wetland or designated conservation or wildlife area without approval from the White County Floodplain Administrator or the Area Plan Executive Director. If located within one-half (1/2) mile of a one hundred (100) year flood plain as determined by the most recent Federal Emergency Management Agency (FEMA) Flood Insurance Rate Maps, all of the system's equipment must be located at least two (2) feet above the one-hundred (100) year frequency flood elevation.

B. Size, Height, Setbacks and Other Developmental Standards

1. All structures shall conform to the standards for principal structures as provided by the Bulk Use Chart (Appendix B) of the zoning district classification for which the development is proposed or to the more restrictive or alternate standard provided for in this Chapter;
2. Utility infrastructure, including support structures for overhead wiring, which connect Battery Storage units to said infrastructure are exempt from the Bulk Use Standards provided for in Appendix B Bulk Use Chart as well as those standards within this Chapter;
3. Any BSF project must have a minimum project area of at least five (5) acres; the minimum five (5) acres may be a stand-alone parcel or a portion of a larger parcel of which five (5) or more acres are leased;
4. No perimeter point of a BSF compound may be closer to a project area property line than thirty (30) feet;
5. Screening shall be provided along any segment of a BSF project area property line abutting a residential zoning district. In addition, where a residential district lies across the road from a property included in a BSF project area, the portion of the BSF project area property line directly across from the residential district property line, plus an extension of twenty (20) feet along said BSF project area property line, in each direction, shall be screened. These screening requirements are hereby waived should a BSF compound be no closer than two hundred-fifty feet to the residential district property line. Also, these screening requirements may be waived with the written consent of the affected property owner(s). Required screening shall meet the following standards:
 - a. Screening may be in the form of a berm or be vegetative in nature (vegetative screenings are preferred) and located between the property line or right-of-way line (whichever is most restrictive) and

the security fence however, no screening shall violate a visual clearance area as provided for in Chapter 3, Subsection 3.07;

1. If vegetative;
 - a. There shall be a minimum of two (2) rows of plantings; the plantings in each row shall be no more than every twenty-five (25) feet apart; the rows shall be separated by no less than six (6) feet and no more than twenty-five (25) feet;
 - b. plantings must reach a minimum height of six (6) feet within two (2) years after planting;
 - c. plantings may be of any variety determined appropriate by the project owner, developer or operator.
2. If a berm;
 - a. the berm shall have a maximum slope of 3:1;
 - b. be a minimum height of six (6) feet tall
 - c. be a maximum height of ten (10) feet tall; and,
 - d. shall be entirely vegetated with ground cover.

Note: For the purposes of Chapter 7 of this Ordinance, a private road does not include driveways, interior service roads or temporary ingress/egress drives or roads constructed and utilized only for the purpose of supporting installation, servicing or monitoring of BSF unit.

6. A BSF may not produce in excess of an hourly average sound level of fifty (50) A-weighted decibels as modeled at the closest outer wall of a dwelling located on any adjacent, Non-Participating property. The sound level maximum may be waived with the written consent of the Non-Participating property owner;
7. The land area of any BSF compound shall not be counted toward the lot coverage maximum as provided for in Appendix B Bulk Use Chart for the applicable zoning district of the subject site;
8. All BSF projects must provide security fencing around the outer edge of each compound in addition to any screening requirements stipulated in Subsection 7.19. B. 5 of this Chapter. Said fencing must provide limited and secured access to prevent entry by unauthorized personnel. Fencing and access gates shall be between six (6) and ten (10) feet tall as measured from the ground grade to the top of the fencing material (post excluded). Note: When a BSF project area is divided into sections as a result of roads/streets, alleys, easements or similar restricted areas, each BSF compound within each section is subject to the security fencing requirements of this subsection;
9. All cables between Battery Storage units and the associated renewable energy development as well as the electric substation and operations &

maintenance buildings shall be buried underground at a depth of at least thirty-six (36) inches below grade. The applicant may request waiver from this requirement. Such waiver must be in writing and addressed to the Area Plan Executive Director, who, at his/her sole discretion may waive such requirement if, in his/her sole opinion, proper justification is made;

10. A BSF project area may not be located within one-half (1/2) mile of any municipality boundary line or GIS boundary line for Buffalo or Idaville. This limitation may be waived, in part or in full, with the written consent of the effected legislative body;
11. The BSF project owner or developer must provide a certification of acknowledgement that they are aware and accept liability for all damages to County regulated waterways, drainage, ditches, field tiles or other drainage related infrastructure caused by the construction, installation or maintenance of a solar energy project and such infrastructure must be repaired by the project owner to near original condition so as not to impede the flow of water as it existed in its pre-damaged state. All repairs must be made in a reasonable time frame and to the satisfaction of the unit and as stated in an applicable lease or other agreement with the landowner subject to applicable federal, state and local drainage laws and regulations.

CHAPTER 8 PARKING AND LOADING STANDARDS

8.0 PURPOSE AND INTENT

The regulations of this Chapter are designed to alleviate or prevent congestion of public streets and other traffic hazards by establishing minimum requirements for off-street parking, loading and storage of motor vehicles, trailers & recreational vehicles. An Improvement Location Permit is required for any new parking lot or any parking lot refurbishment; i.e., resurfacing, restriping, modification or expansion.

8.1 GENERAL STANDARDS

8.1.1 Minimum parking and loading requirements

In the event that the minimum parking requirements established by this Ordinance are less restrictive than what was previously required, it shall not be necessary to restore or maintain parking or loading facilities in excess of those required by this Ordinance.

8.1.2 Parking and loading for uses which have been intensified

When the intensity of an existing use of any building, structure, or premises is increased through the addition of dwelling units, floor area, beds, seating capacity, or other unit of measurement, additional parking and loading facilities shall be provided to accommodate the increase in intensity of use only and the lot shall be brought into compliance with the ADA requirements of this Chapter.

8.1.3 Parking and loading for buildings which have been converted

When the existing use of a building, structure or premises is changed or converted to a new use, parking and loading facilities shall be provided as required for the new use, provided that the new use is permitted by this Ordinance.

8.1.4 Reduction in existing parking and loading facilities

Parking and loading facilities in existence on the effective date of this Ordinance shall not be reduced below, or if already less than, shall not be further reduced below, the requirements for the existing use as prescribed by this Chapter.

8.2 APPLICABILITY

All uses of land except those used for amusement park purposes and located within an AED, Amusement and Entertainment, district or uses within a B-4, General Business Dense Development District, must include on-site parking and loading in accordance with all standards of this Chapter. All uses of land within an AED or B-4 District that provide off-street parking must comply with the ADA requirements of this Chapter, including obtaining an Improvement Location Permit.

8.2.1 On-Street Parking

On-street parking is exempt from the Parking Standards outlined in this Chapter with the exception that all on-street parking shall meet ADA requirements and general parking standards as established by the applicable legislative body; and provided that all on-street parking also meets the requirements of any Federal or State entity which prevails in jurisdiction for on-street parking standards.

8.2.2 Location of accessory off-street parking and loading facilities

Accessory off-street parking and loading spaces are expected to be provided on the same lot as the associated use, except in cases where an entity or entities qualify to utilize shared parking as provided in Section 8.4 of this Ordinance or as provided in the paragraph below.

In any non-residential use of property, any property owner may use an associated lot to help satisfy the parking requirements and needs of the principal use lot (the lot upon which the principal use activity occurs) as long as there is at least one boundary line of the associated lot within three hundred sixty (360) feet of a boundary line of the principal use lot and there are no residential district areas in-between the two. If the parent parcel and the associated parcel have a common property line, they must be combined into a single parcel before a permit shall be issued.

Parking lots may be designed and constructed in a manner which creates more than one (1) parking area (a sectionalized parking lot) as long as all ADA requirements are satisfied.

8.2.3 Off-street parking facilities - prohibition

No required parking facility shall be used for the storage, display, sale, repair, dismantling, or wrecking of any vehicle, equipment, or material.

8.2.4 Sharing of off-street parking facilities

No parking space or any portion thereof shall serve as a required space for more than one (1) use unless otherwise provided for by this Chapter or authorized by the Area Board of Zoning Appeals. Off-street parking facilities intended for separate uses may be maintained collectively so long as the total number of spaces is not less than the sum of the separate requirements for each use or as otherwise provided for in this Chapter, provided that the property complies with all other applicable regulations governing the location of parking spaces for said uses.

8.2.5 Off-street loading and unloading spaces as they relate to required off-street parking

No required off-street loading and unloading space shall be construed as being part of the required off-street parking spaces.

8.2.6 Exception for loading and unloading berths

No loading and unloading berth shall be required for a business use or industrial use which demonstrably does not receive or transmit goods or wares by semi-truck delivery.

8.3 EXISTING PARKING & LOADING AREAS

8.3.1 Use of existing parking and loading areas

No use lawfully established prior to the effective date of this Ordinance shall be required to provide and maintain the parking and loading requirements of this Section, provided that the existing parking and loading spaces are continued and maintained in good condition. However, any such parking lot resurfaced, restriped, modified or expanded must meet the ADA requirements of this Chapter.

8.3.2 Parking and loading areas damaged or destroyed

Any legal or legally nonconforming parking and/or loading area where damage or destruction occurs which is 50% or less of the total parking/loading area, may be reconstructed, re-established or repaired as was prior to the damage or construction as long as such reconstruction, re-establishment or repair occurs within one year from the initial date of damage or destruction. However, in any such instance, regardless of the level of damage or destruction, the parking/loading area must be brought into compliance with the ADA requirements of this Chapter.

Any legal or legally nonconforming parking and/or loading area where damage or destruction occurs and which incurs over 50% of the parking area damaged or destroyed, shall be reconstructed, re-established or repaired in accordance with the requirements of this Chapter.

8.3.3 Parking and loading areas servicing damaged or destroyed conforming or legally nonconforming buildings or structures

Any site where 50% or less of the total gross area for buildings and structures is damaged or destroyed, shall be allowed to retain the parking and loading areas as existed prior to the damage or destruction occurrence, subject to 8.3.2.

Any building or structures damaged or destroyed by more than 50% of the total gross area for buildings and structures located on the applicable site, shall be required to modify or reconstruct parking in compliance with the requirements of this Chapter or, if determined by the Executive Director full compliance cannot be practically achieved, shall modify or reconstruct parking as fully as practical as determined by said Director.

8.4 SHARED PARKING

8.4.1 Shared parking for uses with similar hours of operation

Cooperative provisions for off-street parking may be made by contract between two (2) or more adjacent property owners, provided that the minimum parking requirements for any participating use are not reduced to less than one-half (1/2) the number of required parking spaces for said participating use.

8.4.2 Shared parking for uses which operate at different hours of the day

To the extent that developments wish to make joint use of the same parking spaces operating at different times, up to one-half (1/2) of the parking spaces may be

Amended 03/21/2022: Ordinance No. 22-03-21-01

credited to both uses if one (1) of the uses is a church, theater, or assembly hall whose peak hours of attendance will be at night or on weekends, and the other use or uses are ones that will be closed at night or on weekends. The Executive Director may allow, at his sole discretion, the counting of parking spaces for more than one use should the uses not have an overlap in hours of operation or should a site have excess spaces in accordance to the site's use. In such instances where the volume of business or use allows, shared parking can be authorized by the Executive Director. The request and subsequent authorization, if granted, for shared parking spaces must be provided in writing.

8.4.3 Shared Parking, Temporary Uses

Any temporary use for which a temporary use permit is required may utilize a common parking lot with the principal use as long as the temporary use can demonstrate that it will not require more than ten (10) percent of the parking lot spaces available in the lot, including any spaces consumed by facilities and/or vehicles of the temporary use, and that the proposed parking for the temporary use will not create a nuisance or unsafe condition. Temporary uses may only use parking areas in compliance with this Chapter. The available parking for the temporary use must satisfy all State, Local and Federal ADA Standards.

8.5 PARKING SPACES ACCESSIBLE TO THE DISABLED

White County requires all development within its jurisdiction that serves the public to provide facilities that are accessible to people with disabilities as defined by the Americans with Disabilities Act (ADA) of 1990, as amended from time to time and in compliance with Title II of the ADA. ADA accessible parking shall be provided for any public building or use initiated after the effective date of this Ordinance or in the case where a parking lot refurbishment occurs that involves resurfacing, restriping, modification or expansion. All such development shall comply with the 2005 Guidelines for Accessible Public Rights of Way and the 2010 American with Disabilities Act Standards for Accessible Design and any standard changes or updates required by future changes to Title II of the ADA. All ADA accessible parking shall be in conformance with the following minimum requirements and any further requirements hereafter adopted by federal, state, or local law.

8.5.1 Required spaces

Accessible parking spaces shall be provided at the rate prescribed by Table 8.1, Parking Spaces Accessible to the Disabled. In addition to these requirements, uses with accessible patient parking at outpatient facilities must equal no less than ten percent (10%) of the required parking, and facilities which specialize in treatment or services for persons with mobility impairments shall provide accessible parking equaling no less than twenty percent (20%) of the required parking for patient use.

A minimum of one (1) van accessible space is required for all sites. Sites which require sixteen (16) accessible spaces or more, one (1) van accessible space shall be incorporated into the parking area for each six (6) accessible parking spaces required.

Amended 03/21/2022: Ordinance No. 22-03-21-01

For ADA parking space calculations, two (2) motorcycle half spaces equals one standard parking space, the total of which is added to the parking space total. Each golf cart space counts as a full space toward establishing the ADA parking space requirements.

8.5.2 General ADA design and layout requirements

Access aisles and accessible routes for the mobility impaired shall be provided pursuant to the requirements of this Chapter in addition to any and all ADA requirements as amended from time to time.

ADA has various access route requirements depending on the use of the site. Access routes must be provided as specified by the use in accordance with ADA standards as amended from time to time.

Any access route located in front of a Handicapped spot must install a wheel stop to keep vehicles from reducing the route width to below thirty-six (36) inches.

All access aisles must be level to a maximum of one to fifty (1:50) slope in all directions.

Any van accessible space, access aisle or vehicular route to and from a van space must provide a minimum of ninety-eight (98) inches of clearance.

Each ADA parking space shall be a minimum of nine (9) feet wide and twenty (20) feet in length.

Each ADA parking space shall include an adjacent access aisle as follows: All standard accessible aisles must be a minimum of five (5) feet in width; All van accessible aisles must be a minimum of eight (8) feet in width.

A universal parking space design may be used if applied to all ADA required parking spaces. Universal spaces measure a minimum of eleven (11) feet in width with a minimum five (5) foot access aisle.

ADA parking spaces may utilize a common access aisle.

In cases where a van accessible space and standard space are designed to share an aisle and laid out in ninety (90) degree fashion, the Van Accessible space is to be the one which puts the passenger side of the van next to the access aisle.

Access aisles must be adjacent to the designated parking space. No ramp, bollard or other object shall be placed in or occupy any portion of an access aisle.

No accessible route shall have a curb or stair and must be at least three (3) feet wide pitched no greater than 1:12 in the direction of travel. The surface must be firm, stable and slip resistant.

8.5.3 Design Deviation

Any person or entity may request a design deviation from the ADA requirements upon demonstration to the Executive Director that it is structurally impractical to comply with the requirements of this Chapter or that a Federal Standard is more applicable to site conditions. Any design deviation granted must be granted in

writing and shall only provide the minimum amount of relief necessary and require compliance to the fullest extent possible.

Any deviation granted may allow parking within a setback in order to meet the requirements of this Chapter, but never closer than five (5) feet to any property or right-of-way line.

Departures from particular requirements of this Chapter require approval in writing from the Executive Director and shall only be granted where the alternative(s) will provide substantially equivalent or greater access to and from usability of the facility.

Certain exemptions and additions to ADA requirements and this Chapter are applicable for specific uses as provided for in ADA guidelines. Reference the Americans with Disabilities Act Accessibility guidelines for identification of relief or requirements based on specific use.

8.5.4 ADA loading zones

- A. Passenger Loading: ADA passenger loading zones shall provide an access aisle a minimum of five (5) feet wide and a minimum of twenty (20) feet in length, adjacent and parallel to the vehicle pull up space. If there are curbs between the access aisle and the vehicle pull up space, then a curb ramp shall be installed and maintained in good condition.
- B. Vending Loading Areas: Any vending equipment placed with the intention of offering drive-up service, must provide one ADA accessible loading/unloading space, as well as an ADA access aisle, ADA routing path and ADA pavement markings along with one loading/unloading space for general use. Each loading/unloading space shall be nine (9) feet by twenty (20) feet.

8.5.5 Location

All ADA parking spaces must be located on the shortest accessible route of travel to an accessible facility entrance. Buildings which have multiple accessible entrances with adjacent parking must disperse and locate the spaces to the closest accessible entrances.

8.5.6 Signage and marking

- A. All ADA accessible spaces shall be designated by a sign with the international access symbol. Van accessible spaces shall include an additional sign indicating the space is "Van-Accessible" located below the sign providing the symbol of accessibility.
- B. All ADA signage, excluding the mobility impaired symbol painted on the parking space surface, shall be a minimum of five and one half (5 ½) feet above ground level so as not to be obscured by parked vehicles. The mobility impaired symbol shall also be painted on the ground to the rear of the parking space; the symbol shall be 3' square, centered in the space side to side and no more than 2 ½ feet from the rear of the space to the center of the symbol.

Table 8.1 - Parking Spaces Accessible to the Disabled

In substitution to the “Minimum Number of Accessible Spaces Required” below, uses with accessible visitor and patient parking at Hospital Outpatient Facilities must equal no less than ten percent (10%) of the required parking, and facilities which specialize in treatment or services for persons with mobility impairments shall provide accessible parking equaling no less than twenty percent (20%) of the required parking for visitor and patient use. Upon determination of the minimum number of accessible spaces required, Van Accessible spaces follow the table below.

For ADA parking space calculations, 2 motorcycle half spaces equals one standard parking space, the total of which is added to the parking space total. Each golf cart space counts as a full space toward establishing the ADA parking space requirements.

Total Number of Parking Spaces In Lot	Minimum Number of Accessible Spaces Required	Van Accessible Spaces Required
1 to 25	1	1
26 to 50	2	1
51 to 75	3	1
76 to 100	4	1
101 to 150	5	1
151 to 200	6	2
201 to 300	7	2
301 to 400	8	2
401 to 500	9	2
501 to 1000	2% of total	1 for every six required spaces or fraction of six
1001 and over	20 plus 1 for each 100 over 1000	1 for every six required spaces or fraction of six

8.6 PARKING DEVELOPMENT STANDARDS

With the exception of agricultural uses, automobile sales lots and where specifically exempted elsewhere in this Ordinance, all off-street parking areas shall be developed in accordance with the standards of this Section.

Amended 03/21/2022: Ordinance No. 22-03-21-01

8.6.1 Dimensions

- A. Each required off-street parking space and, when required, its associated back-out aisle shall meet the dimensional standards as provided for in Table 8.2, exclusive of driveways, ramps or other amenities located within a parking area. All off-street parking spaces shall maintain a minimum of eight (8) feet of vertical clearance.
- B. With the exception of Single and Two-Family dwelling units, each off-street parking space shall open directly upon a back-out aisle at a minimum width prescribed by Table 8.2. Said opening is intended to provide safe and efficient means of vehicular access to such parking space. All back-out aisles and driveways shall be unobstructed and allow for the passage of emergency vehicles at all times.
- C. The manner for measuring the depth of a parking space shall be from the parking space front as if the space were laid out as a perpendicular space to the rear edge of the useable space measured at a ninety (90) degree angle, exclusive of any back-out aisle or driveway; see Figure 8.1 for clarification.

Figure 8.1 – Determining the length of an angle parking space

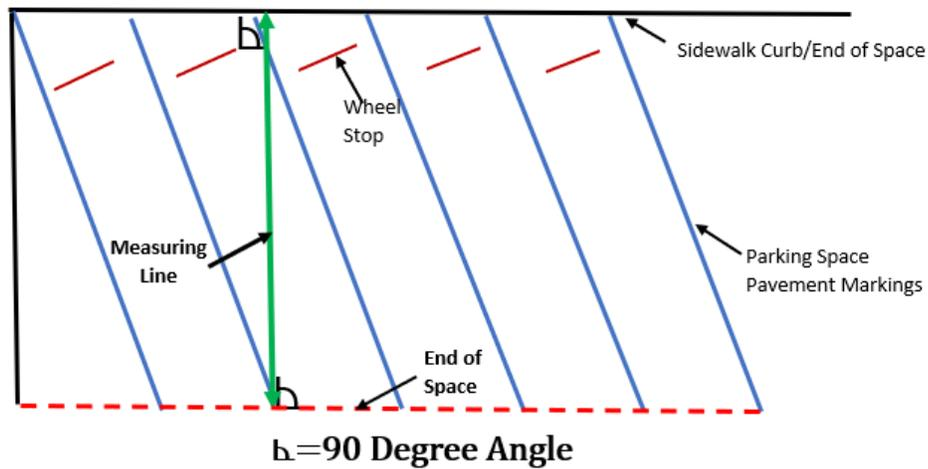

Table 8.2 - Minimum Space and Aisle Dimensions of Parking Spaces

Parking Angle¹ (in degrees)	Space Width (in feet)	Space Depth (in feet)	Back-out Aisle Width⁴ (in feet)
Parallel	9'²	22'	12'
Right Angle	9'	20'	24'
60° angle	9'	18'	18'
45° angle	9'	17'	18'
Small Car ⁽¹⁾	8'	15'	15'
Motorcycle ⁽²⁾	4 ½'	10'	8'
Golf Cart ⁽³⁾	7	10'	10'

¹ Spaces exclusive for compact or subcompact cars may be used only if specifically, designated "For Small Cars Only." A maximum of twenty-five percent (25%) of a parking area may be designated for small cars.

² Motorcycle spaces are voluntary and in addition to the minimum parking space requirements spelled out in this Chapter. The location and aisle width requirement(s) may be modified upon written authorization by the Executive Director

³ Golf cart spaces are voluntary and in addition to the minimum parking space requirements spelled out in this Chapter. The location and aisle width requirement(s) may be modified upon written authorization by the Executive Director.

⁴. Does not apply to single and two family residential units

8.6.2 Layout and design

- A. All off-street parking or loading facilities shall be designed with the appropriate means of vehicular access to a street or alley in a manner so as to lessen interference with traffic movement.
- B. The width of any driveway, as measured at the right-of-way line, shall not be exceeded for a distance of at least six (6) feet onto the subject property.
- C. No part of a parking space may encroach into a visual clearance triangle.
- D. Unless specifically authorized elsewhere in this Ordinance, a gravel area may not be used for vehicular parking.

8.6.2.1 Driveways, Parking Spaces and Back Out Aisles, Additional Standards:

A. Residential Driveways

1. No residential driveway which crosses a public street, private road or public alley right of way line shall exceed a width of thirty (30) feet at the right-of-way line; the driveway width at the right-of-way line must not be exceeded for a minimum of six (6) feet from the property line or right-of-way line whichever is most restrictive.
2. All properties utilized for residential purposes, excluding those in a B-1 or B-4 district, are allowed to have only one of the following driveway configurations:
 - a. A single driveway with a single ingress/egress point not to exceed thirty (30) feet in width at the right-of-way line;
 - b. A single driveway with two (2) driveway ingress/egress points (semi-circular drive), each access point shall be limited in width to twenty (20) feet at the right-of-way line with the closest point of the driveway openings having a minimum of ten (10) feet of separation at the right-of-way line; or,
 - c. Two (2) single point driveways as long as each driveway is under twenty (20) feet in width at the right-of-way line and the driveways maintain a minimum separation of ten (10) feet at all times.
3. All residential driveways within a municipality or the defined limits of Buffalo or Idaville must be constructed of a concrete, asphalt or gravel surface or a material equivalent in durability to concrete or asphalt; all residential driveways outside a municipality or the defined limits of Buffalo or Idaville may be constructed of any material including leaving as dirt.
4. No part of a driveway utilized in conjunction with a residential use shall be closer than two (2) feet from any adjoining side property line unless the property owner provides a waiver properly executed by the abutting property owner. The waiver must be properly executed in writing on a form provided by the Staff. This form must be recorded in the office of the White County Recorder with a copy of the recorded waiver submitted to the Staff. Note: Two properties which share a driveway are exempt from this setback requirement.
5. Within any municipality or within the limits of Idaville or Buffalo, any new/planned driveway which is to cross a sidewalk or curb within any street or road right-of-way or which is intended to enter into a street or road right-of-way must follow the guidelines below:
 - a. The property owner or developer is required to obtain written permission for the development portion within the right-of-way from the appropriate legislative body, or its delegated authority, prior to initiating the driveway improvement.

- b. The driveway design must provide for the lowering of the street curb to be level with the street surface;
- c. The driveway surface is to be level with the existing or anticipated sidewalk;
- d. The driveway must provide an asphalt or concrete surface street approach. This approach shall be a minimum of ten (10) feet in length measured from the property side of the sidewalk or right-of-way line, whichever is most restrictive.
- e. Any portion of the driveway which lies within the road right-of-way shall be constructed in a manner as directed by the local body with jurisdiction over the right-of-way.; and,
- f. All driveways must meet the construction standards of Section 8.6.3, Subsection A.

B. Residential Parking Space Design and Layout

1. Each parking space shall measure the size required by Table 8.2.
2. No part of an area dedicated as a parking space shall be closer to a front property line or right-of-way line than six (6) feet
3. Within a municipality or the limits of Idaville and Buffalo, parking spaces must be surfaced in gravel, concrete, pavement or material equivalent in strength and features to concrete or pavement; in all unincorporated areas of the County, a dirt surface is permissible.
4. Interior parking, either inside a garage or building or under a carport may be utilized to satisfy the site's off-street parking requirement.

C. Commercial, Industrial or Institutional Driveways

1. No part of a driveway utilized in conjunction with a Commercial, Industrial or Institutional use shall be closer than twenty-five (25) feet to any adjoining residential property line, or ten (10) feet to any adjoining nonresidential property line, unless, in the opinion of the Executive Director, the driveway is designed in such a manner as to mitigate interference with traffic movement and visual impairments.
2. Any property used for Commercial, Industrial or Institutional purposes is allowed to cross over a road rights-of-way line with one (1) driveway per each abutting road for access to an employee and/or customer parking lot or for human loading/unloading, whether or not the parking area or loading/unloading zone is located in one section or multiple sections. For purposes of this Chapter, a vehicular travel route utilized to access a property, which is continuous from one ingress/egress point to another, is considered a single driveway. A. Each driveway may have up to two (2) ingress/egress points as long as, at the rights-of-way line, the ingress/egress perimeters are at least ten (10) feet apart (such as would be found on a semi-circular

driveway) and the width of each access point is not greater than thirty (30) feet.

3. In addition, each facility will be allowed up to two (2) driveways to support areas dedicated to shipping and receiving, merchandise loading and unloading, outdoor storage areas or equivalent use areas to the operation.
4. Additional driveways, in a number determined by the Executive Director as necessary for efficient facility use and which he/she determines do not create a site safety condition or significantly negatively contribute to the movement of adjoining traffic, are allowed upon written authorization by said Director.
5. Commercial, Industrial or Institutional driveways may be up to forty (40) feet in width at the right-of-way line. Up to sixty (60) feet in driveway width may be granted by the Executive Director upon demonstration by the property owner or facility operator that the additional width is necessary to create safe routing of vehicles, semi-trucks and trailers and/or facility equipment.
6. Upon written approval of the Executive Director, driveway throats may be allowed up to eighty (80) feet at the right-of-way line if needed to accommodate INDOT or municipality approach requirements. The property owner or facility operator must demonstrate that the additional driveway width is a requirement of INDOT or the municipality and receive written approval of the Executive Director who is to assure such design and location will provide safer vehicle routing as well as be accommodating to safe pedestrian circulation.
7. Within any municipality or within the limits of Idaville or Buffalo, any new/planned driveway which is to cross a sidewalk or curb within any street or road right-of-way, the property owner or developer is required to obtain written permission for such development from the appropriate legislative body, or its delegated authority, prior to initiating the driveway improvement. All such improvements shall meet the following requirements.
 - a. The driveway design must provide for the lowering of the street curb to be level with the street surface
 - b. Structuring the driveway surface to be level with the existing sidewalk
 - c. Provide an asphalt or concrete surface for any portion of the driveway which abuts a sidewalk and then which extends to the Road/Street (not alleys) pavement within the Road/Street right-of-way; and
 - d. All driveways and back-out aisles must meet the construction standards of Section 8.6.3, Subsection A.

D. Commercial, Industrial or Institutional Off-street Parking Space Design & Layout

All required off-street parking spaces shall be designed, arranged and regulated so that:

1. Such concrete or paved parking areas are lined or designated to insure the most efficient use of the parking spaces.
2. Individual spaces shall be located so that no part of the parking lot perimeter, excluding driveways, or any part of a parked vehicle extends any closer than six (6) feet to any front, rear or side property line or right-of-way line, whichever is most restrictive. Parking spaces may not extend into any pedestrian circulation route.
3. Any space which has a front which is bordered by vegetated land, a sidewalk or is within five (5) feet of a building must be restricted by a wheel stop or a curb.
4. All parking spaces shall be unobstructed and have access to a back-out aisle or driveway so that any automobile may be moved without moving another, and so that no maneuvering directly incidental to entering or leaving a parking space shall be on any public right-of-way or walkway. All parking spaces must be positioned so that after backing out of the space, the driver can pull forward out of the parking lot by turning no more than ninety (90) degrees from their pull-out position. Positioning a parking space in a manner which would possibly subject the vehicle to having to reverse position by an angle greater than ninety (90) degrees to exit the parking lot shall be prohibited.
5. All parallel parking spaces shall be set back a minimum of five (5) feet from any wall of a building.
6. All wheel stops shall sit such that the closest side of the wheel stop to the building, sidewalk or vegetated area is no closer to the end of the space than twenty-four (24) inches or eighteen (18) inches for spaces dedicated to compact parking. In a case where curbing abuts a parking space, the sidewalk or vegetated area must be a minimum of five (5) feet in depth. Wheel stops that are used to separate two parking spaces shall have no setback requirement.
7. For commercial or industrial applications, no part of a parking may be closer to any building wall than five (5) feet except for parking spaces located within a building. This requirement may be waived or modified by the Executive Director, if, in his/her sole opinion, waiving or modifying this requirement will not negatively impact pedestrian circulation nor create some other type of potential unsafe condition.
 - a. Off-street parking spaces may be open to the sky or enclosed in a building. In any instance, when a building is constructed on

- a vacant lot, said building shall be treated as a principal structure and shall be subject to all requirements thereof.
- b. Parking areas may accommodate one (1) single story shelter or guard shack which shall not exceed one hundred (100) square feet of gross floor area and shall conform to all the structural requirements of the District in which it is located. The shelter/guard shake may be located no closer than 6' from front property line or right-of-way line, whichever is most restrictive, and may not encroach into visual clearance area.
 - c. When determined necessary by the Executive Director, a parking area shall provide a means of pedestrian circulation to its associated use as well as between the associated use and the street. All pedestrian circulation routes designed within the parking lot area must be so designated with appropriate markings on the pavement. Each parking space area must be accessed by a sidewalk or cross hatched pavement area. Each sidewalk or cross hatched pavement area must be a minimum of three (3) feet wide.
 - d. Any lighting used to illuminate any off-street parking area shall be so located, shielded and directed upon the parking area in such a manner that it does not reflect or cause glare onto adjacent properties or interfere with street traffic. In no instance shall bare, unshaded bulbs be used for such illumination

8.6.3 Surfacing and drainage

- A. With the exception of parking dedicated for ballfields/parks, campgrounds and amusement parks, Laydown Yards, or, unless specifically exempted elsewhere in this Chapter, all open, off-street parking areas, including but not limited to parking spaces, drives and back-out aisles, shall be surfaced with an all-weather, dust-free concrete or asphalt material. Minimum construction of all parking spaces, drives and back-out aisles developed in conjunction with commercial, industrial or institutional uses shall consist of no less than eight (8) inches of an aggregate material and four (4) inches of surface material or certified to a standard which, in the sole discretion of the Executive Director, is determined to be equal or better than the construction standard required. Upon written approval from the Executive Director, an aggregate surface may be used for a period not exceeding one (1) year after the date of granting the Certificate of Occupancy. This exception does not apply to any portion of the parking area required to satisfy ADA requirements. All open, off-street parking areas shall be maintained in good condition and free of weeds, dirt, trash and debris
- B. All aggregate parking lots must comply with ADA requirements of this Ordinance unless specifically exempted by Federal Law

- C. All open, off-street parking areas shall be graded and properly drained in such a manner that there will be no free flow of water onto either adjacent property or public sidewalks. Further, any additional run-off generated by such improved areas shall be disposed of in appropriate drainage facilities
- D. In any paved parking area that does not have wheel stops; the surface shall be painted, marked, or otherwise delineated so that each parking space is readily apparent.

8.7 PARKING AND STORAGE OF CERTAIN VEHICLES

8.7.1 Nuisance vehicles

With the exception of those located within a completely enclosed structure, automotive vehicles or trailers of any type which are without current registration or any inoperable automotive vehicle shall be prohibited in all residential zoning districts. Unless specifically authorized under the terms of this Ordinance, no automotive vehicle or trailer of any type which is without current registration, or any inoperable automotive vehicle or trailer not enclosed in a structure shall be parked or stored in any non-residential district.

8.7.2 Commercial vehicles

The parking of commercial, self-propelled vehicles, excluding semi-trucks or tractor trailers, shall be prohibited in all residential zoning districts unless the vehicle is used by the occupant of the premises. No more than one (1) semi-truck or tractor trailer, at a time, is allowed to be parked or stored on any residential lot. This requirement shall not be interpreted to prohibit commercial vehicles from temporary loading and unloading in any residential district.

8.7.3 Temporary/Portable Storage Units

Temporary/portable storage units shall be permitted in any residential district, provided that they comply with the following minimum standards:

A. Time Limitation

No temporary/portable storage unit may be located on any site, in any residential district for a period longer than ten (10) consecutive days from time of delivery to time of removal. At the end of such period, the temporary storage unit shall be moved off-site and shall not be returned for at least one (1) month from the date it was removed. This does not apply to a dumpster used in conjunction with a construction, reconstruction, remodel or refurbishment project. Dumpsters may remain for the duration of the construction activity but must be removed within seven (7) days from the day the construction activities cease.

B. Number of Units

No more than two (2) temporary/portable storage units may be located on a lot of record at one time.

C. Location

No temporary/portable storage unit may be located closer than ten (10) feet to any property line. Under no circumstances may a temporary/portable storage unit be located within a public right-of-way.

D. Removal

In the event of high winds or other adverse weather conditions in which such a structure may become a physical danger, the Executive Director or any law enforcement officer may require the immediate removal of such temporary structure. In the event that a unit has been in place longer than the time period specified in (a) above, the Executive Director shall cause said structure to be removed. In any instance, all costs associated with the removal of a temporary/portable storage unit shall be the responsibility of the landowner

E. Use

No temporary/portable storage unit shall be used to store solid waste, construction debris, demolition debris, recyclable materials, business inventory, commercial goods, or any illegal or hazardous material.

8.8 DESIGN FLEXIBILITY

8.8.1 Reduction of parking

Due to particularities of any given development, the application of the minimum parking requirements prescribed by this Chapter may result in parking spaces and loading areas which exceed the need of the associated uses. Upon written request of the applicant, the Executive Director may authorize a reduction in the minimum parking requirements, provided that the reduction is no more than fifty (50) percent of the minimum parking requirements for said use. Approval of a reduction in the number of required parking spaces by the Executive Director shall be in writing and shall include justification for allowing such reduction.

8.8.2 Phasing of minimum parking requirements

Upon written request by the applicant, up to twenty-five (25) percent of a dedicated parking area may remain unpaved greenspace until such time as the remainder of the parking area is needed. This decision and determination shall be at the discretion of the Executive Director. Such greenspace shall not be counted toward required parking landscaping or buffer yard as specified in Chapter 9, Landscaping Standards.

8.8.3 Deviation from minimum parking requirements

Applicants submitting development plans for the B-1 Neighborhood Business District, may submit an alternative plan not meeting the requirements of this Chapter if space limitations prevent compliance with this Chapter. Such plans are subject to approval, denial or revision as determined by the Executive Director.

8.9 DRIVE-THROUGH AND SERVICE POINT STACKING SPACE REQUIREMENTS

All establishments with a drive-through window or customer service point such as a fuel pump or pick-up door, shall provide a minimum number of stacking spaces for the queuing of vehicles awaiting use of such facilities. All required stacking spaces shall be in addition to the required parking spaces for the facility and in addition to the parking space for the vehicle using the drive-through window or service point. No required stacking space shall be located within a required driveway, internal circulation system, or parking aisle.

8.9.1 Stacking lane dimensions and markings

Each stacking space shall be a minimum of eighteen (18) feet long, and each lane of stacking spaces shall be a minimum of nine (9) feet wide. Lane widths should be delineated with pavement markings. Individual stacking spaces within the lane need not be marked.

8.9.2 Number of stacking spaces

Table 8.3, Minimum Required Vehicle Stacking Spaces denotes the number of stacking spaces required for common drive-through or service point uses.

Table 8.3 Minimum Required Vehicle Stacking Spaces

Activity Type	Minimum Stacking Spaces	Measured From
ATM	1	Per Machine
Bank teller lane	4	Teller or Window
Restaurant, drive-through	6	Staging for Order box
Restaurant, drive-through	4	Order box to pick-up window
Car wash, automatic	6	Each stall entrance
Car wash, full service	6	Each service entrance
Car wash, self service	3	Each stall entrance
Gasoline pump island	2	Each service side of a pump or pump island
Truck stop island	2	Each service side of a pump or pump island regardless of the number of pumps
Truck wash	2	Each wash station entrance
Other uses not specified	As prescribed by the Executive Director, but never less than two (2).	

8.10 LOADING SPACE REQUIREMENTS

Uses and buildings with a gross floor area of five thousand (5,000) square feet or more which receive or transmit goods or wares by truck delivery shall provide off-street loading spaces in accordance with Table 8.4, Loading Space Requirements. Spaces which accommodate off-street loading shall not be used to satisfy any required off-street parking requirements. External or internal loading docks may be counted to satisfy the requirements of this Section.

Table 8.4 – Loading Space Requirements

Use Description	Floor Area in Square Feet	Number of Loading Spaces Required
Manufacturing, distribution, wholesaling, industrial warehouse, commercial storage, and similar uses	5,000 - 25,000	1
	25,001 - 60,000	2
	60,001 – 100,000	3
	Each 50,000 above 100,000	1
Office Buildings, hotels and motels, retail sales, hospitals, institutions, and similar uses	5,000 – 60,000	1
	60,001 – 100,000	2
	Each 10,000 above 100,000	1
Recycling Satellite, Private		As determined by the Executive Director
Recycling Satellite, Public		2 per recycling container or recycling trailer (1/side)
Other uses not specified	As prescribed by the Executive Director	

Boat Storage facilities must provide a rectangular loading and unloading space which extends the entire length of the facility and perpendicular to the building a minimum of fifty (50) feet. This is in addition to satisfying any ADA requirements established by this Ordinance or by Federal or State law, code or regulation.

8.10.1 Location

All required off-street loading berths shall be located on the same lot as the use they are intended to serve. No portion of any off-street loading area shall cause any vehicle to project into an adjacent street or alley right-of-way. No permitted or required loading berth shall be located within twenty-five (25) feet of the nearest point of intersection of any two (2) streets, nor shall it be located in a required front yard or side yard adjoining a residential use or district.

8.10.2 Size

Each required off-street loading space shall be accessible when the off-street parking spaces are at their capacity. In addition, all off-street loading spaces shall be in conformance with the following:

- A. For local pick-up and delivery trucks: twelve (12) feet in width by thirty (30) feet in length with a forty-five (45) foot maneuvering apron, and a twelve (12) foot height clearance. The maneuvering apron must be comparable to the detailed requirements noted in "B." below.
- B. For over-the-road tractor-trailers: fourteen (14) feet in width by sixty (60) feet in length with a sixty (60) foot maneuvering apron, and a fifteen (15) foot height clearance. The maneuvering apron shall be a minimum of 60' long and 14' wide and will be an extension of the loading space requirement. This results in an area dedicated to the loading space and maneuvering apron of no smaller than 14' wide x 120' long. The 120' of length is required to be entirely on the property, none may be delineated in a right of way. The maneuvering area may coincide with a driveway or parking lot aisle as that area would not be used by the truck for anything else but maneuvering so any parking space blockage would be very short lived.
- C. An alternative to this design requirement may be submitted and if the alternative design provides safer or more efficient use of land without purposes of the parking lot impaired, restricted or altered and better accomplishes the ability of a truck to properly position itself for loading/unloading, the Executive Director may provide approval to the alternative design. Such approval must be in writing and in advance of issuing an improvement location permit for the subject development.
- D. At no time can the loading space occupy a dedicated parking space nor may it be laid out in a manner which could block or prevent ingress/egress to a vehicle parking space or other amenity of the parking lot
- E. For loading/unloading of any Class 1 vehicle, nine (9) feet in width by twenty-two (22) feet in length.

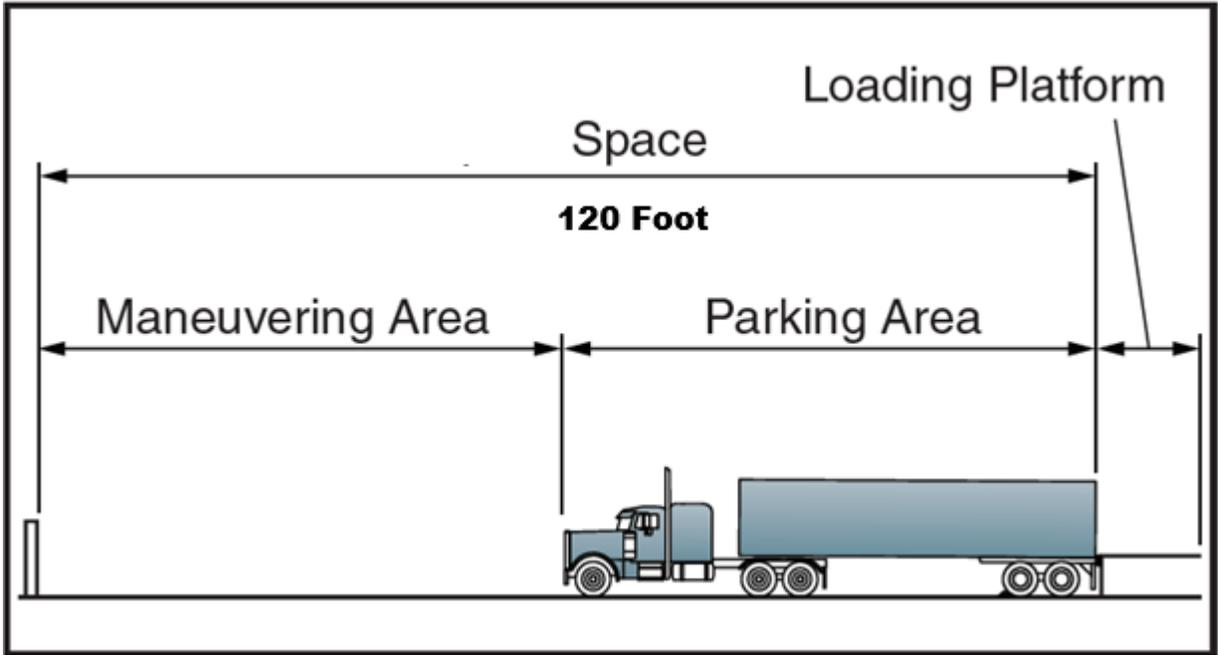

8.10.3 Surface

Unless otherwise permitted by this Ordinance, all open off-street loading spaces shall be improved with an aggregate base with a minimum thickness of six (6) inches and surfaced with not less than two (2) inches of asphaltic concrete or some comparable all-weather dustless material. In addition, paving and drainage regulations for loading areas shall be in accordance with the paving and drainage regulations for parking areas as set forth in this, or any other applicable Ordinance.

8.10.4 MINIMUM SETBACK DISTANCES FOR CERTAIN PARKING AND LOADING SPACES

A parking area or loading space for any of the following uses shall be setback from all residential zoning districts as prescribed by Table 8.5, Minimum Setback Distances for Certain Parking/Loading Areas, following.

Table 8.5 - Minimum Setback Distances for Certain Parking/Loading Areas

Use	Parking Area	Loading Area
Airport	25 feet	100 feet
Commercial facilities for raising or breeding non-farm fowl & animals	25 feet	100 feet
Commercial greenhouse	N/A	50 feet
Junk yard	1,320 feet	1,320
Outdoor commercial recreation uses	25 feet	50 feet
Penal or correctional institution	300 feet	300 feet
Private recreational development	25 feet	50 feet
Sales barn for livestock sale	50 feet	100 feet
Truck terminal	100 feet	100 feet
Wholesale produce terminal	100 feet	100 feet

8.11 ADDITIONAL REQUIREMENTS FOR OFF-STREET PARKING AND LOADING PLANS

Off-street parking facilities shall be developed in accordance with the provisions of this Section.

8.11.1 Off-street parking and loading plan

An off-street parking and loading plan shall be filed as part of any required site development plan, and shall be made part of the conditions of any approval thereof. Said off-street parking and loading plan shall demonstrate compliance with Chapter 12, Administration, of this Ordinance. Said off-street parking and loading plan shall indicate:

- A. All individual primary uses to be served, including the location of the use and number of parking spaces for each such use;
- B. lanes, parking spaces, setbacks, drainage facilities;
- C. Landscaping and buffer screening;
- D. Type of lighting and paving proposed, and,
- E. Identification of signs, including their location, size and design thereof.

- F. At the sole discretion of the Executive Director, a business location where on-street parking or public parking lots are available, the Executive Director may provide a parking space allowance in a quantity he/she determines is appropriate against that business' off-street parking space.

8.11.2 Lease or easement

Off-street parking facilities encumbered by any instrument (lease or easement) duly executed and acknowledged, which subject said accessory off-street parking facilities to parking uses in connection with the primary use served. Said instrument shall specify and bind the time period to the anticipated life of the building or use to which the parking facilities are accessory. Said instrument shall be filed in the applicable Permit files of the Office of the Executive Director, and placed on public record in the office of the White County Recorder.

8.11.3 Setbacks

Off-street parking structures, commonly referred to as a parking garage, shall be provided with setback distances equivalent to the requirements of the district for principal structures unless otherwise provided for in this Ordinance. Points of ingress and egress shall be limited to protect the function of adjoining streets.

8.11.4 Minimum number of spaces required

The minimum number of required off-street parking spaces shall be provided according to Table 8.6, Required Off-Street Parking Spaces unless otherwise specified in this Ordinance.

8.11.5 Calculating the minimum number of spaces required

In determining the minimum required number of off-street parking spaces, the following instructions shall be applicable to such computations:

- A. Any fraction of less than one-half (1/2) shall be disregarded, while a fraction one-half (1/2) or greater shall be counted as one parking space.
- B. For uses not specified in this Section or when the adequate number of spaces is unclear, the minimum number of spaces shall be determined by the Executive Director. The Executive Director shall base the minimum number of parking spaces required on the basis of similar requirements, the number of persons served or employed, and the capability of adequately serving the visiting public. Such determination may be reviewed by the Area Plan Commission or appealed to the Board of Zoning Appeals.
- C. In sports arenas, churches and other places of assembly in which patrons occupy benches, pews, or other similar seating, each twenty-two (22) inches of such seating shall be counted as one (1) seat for the purpose of determining requirements, unless otherwise stated.
- D. In the case of open floor areas used for temporary seating purposes, an area of sixteen (16) square feet usable for seating shall be counted as one (1) seat for the purposes of administering and enforcing this Chapter.

- E. For the purposes of determining off-street parking requirements under this Chapter, gross floor area shall mean the total horizontal area of each floor of all buildings excluding guard shacks and accessory buildings of three hundred square feet or less. Public floor space/area is gross floor area less areas devoted entirely and permanently to storage purposes, parking and loading facilities, or space used for restrooms, utilities, machinery rooms, stairs or elevator shafts/lifts. In the case of a restaurant, bar areas are included while the area dedicated to kitchen facilities shall be excluded.
- F. For the purposes of calculating parking requirements, each category of use on a lot shall be considered separately, unless otherwise provided for by this Chapter.
- G. Unless otherwise provided for by this Chapter, the number of required off-street parking spaces shall be considered the minimum number of spaces required for any particular use.
- H. Every company car, truck, tractor-trailer normally stored at a business site shall be provided with an off-street parking space. Such space shall be in addition to the minimum parking requirements listed in Table 8.6, Required Off-Street Parking Spaces.
- I. Event Barn, Excess Parking: Excess parking is an open area where peak parking is allowed and has either a gravel or grass surface. To calculate the number of parking spaces credited for an excess parking area, a site plan should delineate the parking configuration of the area as if the lot were to be paved utilizing the space and aisle sizes provided for in this chapter.

8.11.6 Administrative Adjustment

Any applicant may request an adjustment from the minimum parking standards. The request must be in writing and include a justification for the adjustment. If, in the sole discretion of the Executive Director, the justification allowance is quantifiable, credible and does not exceed 50% of the minimum requirement, the Executive Director may adjust the minimum parking requirements for the applicant's site to the level the Executive Director determines is warranted, which may or may not be less than the applicant requested. Any decision of the Executive Director on this matter may be appealed to the Area Board of Zoning Appeals.

8.12 ELECTRIC VEHICLE CHARGING STATIONS

All parking areas may include spaces for public or private electric vehicle charging stations. The spaces for electric vehicle charging stations may be included in the total parking space count requirement of a site. ADA accessible electric vehicle charging stations shall not count toward any ADA parking requirements applicable to the site.

8.12.1 General Requirements

- A) Setbacks: All Electric Vehicle Charging Stations (EVCS), public and private, including charging station equipment and support structures are subject to parking lot developmental standards with a height restriction of nineteen (19) feet. EVCS parking spaces and any EVCS Accessible parking space or associated component is subject to the standards, regulations and requirements of this Chapter.
- B) Private EVCS:
 - 1. Private EVCS locations are exempt from the Improvement Location Permit requirement.
 - 2. All private, EVCS locations are permitted in every zoning district when accessory to the primary, permitted use.
- C) Public EVCS:
 - 1. Each site which offers one or more Public EVCS's, must obtain an Improvement Location Permit prior to installation. Each EVCS Improvement Location Permit can cover multiple EVCS's when the EVCS installations are to be located on the same parcel and requested simultaneously under the same permit.
 - 2. Each public EVCS must be located at the head or side of a parking space. The parking space must meet the standards for parking spaces found in Chapter 8 of the White County Indiana Zoning Control Ordinance and, in addition, utilize a wheel stop, bollards, curb, concrete island or other appropriate barrier to prevent vehicular damage to the EVCS equipment and its infra-structure.
 - 3. Each public EVCS parking space must have an EVCS designated pavement marking, a minimum of two (2) foot square in size and no further than two (2) feet from the end of the space and centered accordingly. Said marking shall be painted utilizing a green background and white symbols such as that shown below. Alternative images are acceptable under the required color scheme as long as they effectively convey the message for the purpose of the parking space.



4. All public, EVCS locations, where vehicle electrical charging is one of the principal services provided at the site, shall be categorized for use as either a gasoline service station, neighborhood convenience store or regional convenience store based on the services and amenities offered and shall follow such zoning regulations as are applicable to the use assignment.
5. Each public EVCS site must comply with the following accessibility requirements:
 - (a) Provide a minimum of one (1) Van accessible EVCS space;
 - (b) Provide one (1) additional Van accessible EVCS space for each ten (10) EVCS spaces beginning with space eleven (11);
 - (c) Each accessible EVCS space must comply with all ADA standards applicable to ADA parking spaces, access aisles and routing; and,
 - (d) Each accessible EVCS space shall incorporate accessible access to EVCS equipment and connection devices.

Table 8.6 - Required Off-Street Parking Spaces*

***These are in addition to stacking and/or loading requirements defined elsewhere in this chapter.**

Use Category	Minimum Parking Requirements
Adult entertainment business	1 space per 200 square feet of building gross floor area
Agri bio production	1 space for every 400 square feet of building gross floor area.
Agricultural industry	1 space for every 400 square feet of building gross floor area.
Agricultural produce business, permanent	1 space for every 200 square feet of building gross floor area.
Agricultural produce business, seasonal	None
Agricultural produce sales, portable	None
Agricultural research firm	1 space for every 400 square feet of building gross floor area.
Agricultural roadside stand	None
Agriculture	None
Agriculture service & support	1 space for every 400 square feet of building gross floor area.
Airport	1 space per 2 employees plus 1 space per passenger based on daily transient aircraft
Amphitheater	At the Executive Director's sole discretion, to be determined by the requirements as provided in subsection 8.11.5 C or D;
Amusement park (This is used for the purposes of establishing ADA parking requirements for the operations).	1 space per three thousand (3,000) square feet of outdoor active recreation space, plus any additional spaces required for ancillary uses such as, but not limited, to game centers, theaters, restaurants, rides, amusements and billiard halls.
Amusement park offices (Located in a non-AED District); otherwise, refer to "Business Office" requirements	1 space for every 400 square feet of building gross floor area.

White County Zoning Ordinance Parking and Loading Standards

Use Category	Minimum Parking Requirements
Animal sanctuary	1 space for every 400 square feet of building gross floor area.
Animal shelter	3 spaces per 1,000 sq.ft. of gross floor area
Antennae, amateur radio; radio; television	None
Antennae, radio	None
Antennae, television	None
Apartment	2 spaces per apartment
Apartment, accessory	1 space in addition to primary dwelling requirements
Apartment, micro-unit	1 space per unit
Arcade	See Recreational Facility, Indoor
Asphalt plant (manufacturing)	1 space for every 400 square feet of building gross floor area; plus, 1 space for each vehicle company vehicle
Auction sale	None
Assisted living facility	1 space per 3 sleeping rooms; plus 1 space per employee on the largest shift
Auction arena or sales barn (for livestock)	Requirements as provided in Section 8.11.5
Auction arena or sales yard (excluding livestock)	1 space per 150 sq.ft. building gross floor area space; plus 1 space per 50 sq.ft. seating/standing area
Automated teller machine	None; but, must provide stacking space as required by Section 8.9
Automobile convenience mart	1 space for every 150 square feet of building gross floor area.
Automobile parts/supply retail establishment	1 space for every 150 square feet of building gross floor area.
Automobile rental/leasing establishment	1 space for every 400 square feet of building gross floor area.
Automobile sales	1 spaces per 600 sq.ft. of building gross floor area; plus 2 spaces per service bay.

White County Zoning Ordinance Parking and Loading Standards

Use Category	Minimum Parking Requirements
Automotive service; major	1 space per 400 square feet of building gross floor area; plus, 2 spaces per service bay
Automotive service; minor	1 space per 400 square feet of building gross floor area; plus, 2 spaces per service bay.
Bail sales	See retail establishment (0 to 99,999 gsf)
Bake sale	None
Bakery or delicatessen	See retail establishment (0 to 99,999 gsf)
Ballroom	1 space per 600 square feet of building gross floor area
Bank	1 space per 400 square feet of building gross floor area
Banquet Hall	1 space per 600 square feet of building gross floor area
Bathhouse	None
Batting Cages, Commercial	1; plus, 1 space per cage
Bazaar	None
Bed and breakfast	1 space per guest room; plus, 1 space per employee; plus, 2 spaces for owners.
Bio-medicine facility	1 space per 400 square feet of building gross floor area
Bio-processing plant	1 space per 400 square feet of building gross floor area
Boarding house/rooming house	2 spaces; plus 1 space per sleeping room
Boat sales & service	See Automobile Sales
Boat storage, commercial	Loading/Unloading paved, maneuvering area extending fifty (50) feet from all entrance/exit points along the entire entrance/exit wall of the building.
Body piercing (See personal/professional services)	
Botanical garden/botanic garden/botanical institution	1 space per 150 sq.ft. of indoor exhibit area
Bottled gas storage and distribution yard	1 space per 400 square feet of building gross floor area

White County Zoning Ordinance Parking and Loading Standards

Use Category	Minimum Parking Requirements
Bowling Alley	5 spaces per lane
Brew pub	One (1) parking space for each fifty; (50) square feet of building gross floor area; plus, one (1) space for each two hundred (200) square feet of outdoor dining and entertainment area
Brewery	One (1) parking space for each fifty; (50) square feet of building gross floor area; plus, one (1) space for each two hundred (200) square feet of outdoor dining and entertainment area.
Brewery, craft	One (1) parking space for each fifty; (50) square feet of building gross floor area; plus, one (1) space for each two hundred (200) square feet of outdoor dining and entertainment area.
Brewery, micro	One (1) parking space for each fifty; (50) square feet of building gross floor area; plus, one (1) space for each two hundred (200) square feet of outdoor dining and entertainment area.
Bunkhouse	None
Bus garage	1 space per 400 square feet of building gross floor area
Bus lot	1 space per 400 square feet of building gross floor area
Bus station (passenger)	1 space per 200 square feet of building gross floor area.
Business Office	1 space per 400 square feet of building gross floor area
Cabana	None
Cabin	2 spaces (per residential standards)
Campground	1 space per camp site plus 2 spaces per cabin (per residential standards)
Carwash	1 space per 400 square feet of building gross floor area
Caretaker home	1 space (per residential standards)
Carnival	None

White County Zoning Ordinance Parking and Loading Standards

Use Category	Minimum Parking Requirements
Carport	None
Casino	Refer to Chapter 8, 'Calculating the minimum number of spaces required' for details
Catering service	1 space per 400 square feet of building gross floor area
Cemetery	1 space per 400 square feet of building gross floor area
Child care center	1 space per employee on the largest shift; plus, 1 space per 5 children (per residential standards).
Child care home *(1)	1 space per employee on the largest shift; plus, 1 space per 5 children (per residential standards); this is in addition to the spaces required for dwellings if the site is also used as a residence.
Child care house	2 spaces (per residential standards); these spaces may be shared spaces with those satisfying the residential requirements of the site
Children's play equipment	None
Christmas tree sales	None
Circus	None
Club or lodge, private	One (1) parking space for each fifty; (50) square feet of building gross floor area; plus, one (1) space for each two hundred (200) square feet of outdoor dining and entertainment area. 1 space per 4 persons at maximum capacity
Commissary	1 space per 400 square feet of building gross floor area
Community center	1 space per 250 sq. ft. of building gross floor area
Community commons (pocket park)	None
Concessions	None
Concrete or cement batching plant, permanent	1 space for every 400 square feet of building gross floor area; plus, 1 space for each vehicle company vehicle

White County Zoning Ordinance Parking and Loading Standards

Use Category	Minimum Parking Requirements
Concrete or cement batching plant, portable	None
Condominium (per IC 36-1-6 as amended)	Refer to the requirements for Multi-family dwellings
Conference center/meeting hall	1 space per 250 sq. ft. of building gross floor area
Conference facility	1 space per 250 sq. ft. of building gross floor area
Confined feeding operation	None
Construction yard/lay down yard	1 per 300 square feet of building gross floor area; plus, 1 space per vehicle used in conjunction with the business None
Construction, heavy contractors	1 space per 400 square feet of building gross floor area
Convenience store, neighborhood	1 spaces per 400 sq.ft. of building gross floor area
Convenience store, regional	1 space per 300 sq.ft. of building gross floor area
Convention center/exhibition hall	1 space per 250 sq. ft. of building gross floor area
Correctional/penal facility/prison/jail	1 space per 400 square feet of building gross floor area
Cottage/summer home	2 spaces
Crematory	1 space per 800 square feet of building gross floor area
Day care center, adult	1 space per 400 square feet of building gross floor area
Digester, aerobic or anaerobic	1 loading space per digester
Distillery	One (1) parking space for each fifty; (50) square feet of building gross floor area; plus, one (1) space for each two hundred (200) square feet of outdoor dining and entertainment area.
Distillery, micro or boutique	One (1) parking space for each fifty; (50) square feet of building gross floor area; plus, one (1) space for each two hundred (200) square feet of outdoor dining and entertainment area.
Distribution center	1 space per 400 square feet of building gross floor area

White County Zoning Ordinance Parking and Loading Standards

Use Category	Minimum Parking Requirements
Driving range	1 space per 3 tee sites; plus 1 space per 400 square feet of building gross floor area
Dwelling, attached single-family	2 spaces per dwelling unit (per residential standards)
Dwelling, farm	2 spaces (per residential standards)
Dwelling, multi-family	1.75 per dwelling unit (per residential standards)
Dwelling, single-family	2 spaces per dwelling unit (per residential standards)
Dwelling, student/fraternity/sorority	1 space per 250 square feet of building gross floor area
Dwelling, two-family	2 spaces per dwelling unit (per residential standards)
Educational facility, college, university, public or private	1 space per classroom and 1 space per 400 square feet of building gross floor area
Educational facility, elementary, secondary (up to grade 12), public or private	(K-8) 1 space per classroom plus, one space per 400 square feet of gross floor area ; (9-12) 1 space per classroom; plus, one space per 100 square feet of institutional floor area
Educational facility, other, public or private	1 space per classroom; plus, one space per 400 square feet of building gross floor area
Entertainment facility, commercial;	1 space per 150 feet of building gross floor area
Engine Repair, Large	See Automobile Service, Major
Engine Repair, Small	See Automobile Service, Minor
Equipment sales and leasing	See Retail or Wholesale for requirements
Event Barn	1 space per 200 square feet of gross floor area. In unincorporated areas of the County, a minimum of 25% of the parking requirement must be paved in compliance with this Chapter, the balance may be developed under the Excess Parking Standard section of this Chapter. All ADA accessibility provisions must meet all ADA requirements.
Event government	None
Event, special	None

White County Zoning Ordinance Parking and Loading Standards

Use Category	Minimum Parking Requirements
Event, sporting	None
Ethanol plant	1 space per 400 square feet of building gross floor area
Explosives, use or storage	1 space per 400 square feet of building gross floor area
Fairgrounds	1 space per 400 square feet of building gross floor area
Farm chemical/fertilizer supplier	See Retail or Wholesale for requirements
Farming, micro	None
Festival	None
Fire, police (w/o jail facilities), postal stations	1 space per 400 square feet of building gross floor area
Fireworks sales	See Retail or Wholesale for requirements
Flea market	See Retail or Wholesale for requirements
Funeral home or mortuary	1 space per 400 square feet of building gross floor area
Garage, attached	1 space (per residential standards)
Garage, detached	1 space (per residential standards)
Gasoline service station	1 space per 400 square feet of building gross floor area; plus, 2 spaces per service bay
Go-kart facility	1 space per 400 square feet of building gross floor area; plus, 1 space per 400 square feet of outdoor recreational area
Golf course	4 spaces per golf holes; plus, 1 space per 400 square feet of building gross floor area
Government building	1 space per 1,000 square feet of building gross floor area other than office area; plus, 1 space for each vehicle used in conjunction with the facility's use plus 1 space per 200 square feet of general office area.
Grain elevator	1 space per 200 square feet of building gross floor area
Grandstand	1 space per 4 seats at maximum capacity

White County Zoning Ordinance Parking and Loading Standards

Use Category	Minimum Parking Requirements
Greenhouse, commercial	1 space per 400 square feet of building gross floor area
Greenhouse, non-commercial	None
Grocery store or supermarket	See Retail or Wholesale for requirements
Group home	2 spaces; plus, one space per 3 sleeping rooms
Guard shacks	1 space; plus, 1 space for every 200 square feet of building gross floor area over 100 square feet
Guest house	2 spaces (per residential standards)
Gun sales	See Retail or Wholesale for requirements
Gun smith	1 space per 500 sq.ft. of building gross floor area
Hatchery, commercial	1 space per 400 square feet of building gross floor area
Hazardous waste landfill/facility	1 space per 400 square feet of building gross floor area
Health and fitness center	1 space per 200 square feet of building gross floor area 5 spaces per 1,000 sq.ft. of gross floor area
Health center, public	1 space per 150 square feet of building gross floor area
Heliport	2 spaces per aircraft landing station
Home occupation	See respective dwelling unit requirement
Hospital	1 space per 300 square feet of building gross floor area plus 1 space per hospital vehicle
Hotel	1 space per sleeping room; plus, 1 space for every 750 square feet of main floor gross floor area
Incinerator	1 space per 400 square feet of building gross floor area
Industrial park	Refer to Chapter 8, "Calculating the minimum number of spaces required" for details

White County Zoning Ordinance Parking and Loading Standards

Use Category	Minimum Parking Requirements
Industrial waste facility	1 space per 400 square feet of building gross floor area
Information center, visitor/tourist	1 space per 400 square feet of building gross floor area
Integrated Center	1 space per 150 square feet of building gross floor area
Internet selling establishment/e-bay store	1 space; plus, 1 space per 600 sq.ft. of building gross floor area
Jail	1 space per 400 square feet of building gross floor area
Junkyard	1 space per 400 square feet of building gross floor area
Kennel, commercial	1 space per 400 square feet of building gross floor area
Kennel, private	1 space per 400 square feet of building gross floor area
Laboratory, commercial	3 spaces per 1,000 sq.ft. of building gross floor area up to 20,000 sq.ft.; plus, 2 spaces per 1,000 sq.ft. of building gross floor area greater than 20,000 sq.ft.
Laboratory, medical or dental	3 spaces per 1,000 sq.ft. of building gross floor area up to 20,000 sq.ft.; plus, 2 spaces per 1,000 sq.ft. of building gross floor area greater than 20,000 sq.ft.
Laboratory, research activity & testing	3 spaces per 1,000 sq.ft. of building gross floor area up to 20,000 sq.ft.; plus, 2 spaces per 1,000 sq.ft. of building gross floor area greater than 20,000 sq.ft.
Land use amenity	None
Landfill	1 space per 150 square feet of building gross floor area
Landfill, sanitary	1 space per 150 square feet of building gross floor area
Landscape contractor	1 space per 400 square feet of building gross floor area; plus, 1 space for each vehicle used in conjunction with the business
Laundry facility, self-service	1 space per 300 sq. ft. of building gross floor area
Laundry or dry cleaning facility	1 space per 300 sq. ft. of building gross floor area

White County Zoning Ordinance Parking and Loading Standards

Use Category	Minimum Parking Requirements
Laydown Yard	See "Construction Yard"
Library	1 space per 400 square feet of building gross floor area
Manufactured home	2 spaces (per residential standards)
Manufactured home office, permanent	1 per 400 square feet of building gross floor area
Manufactured home park or subdivision	2 spaces per mobile home or trailer stand
Manufactured home park or subdivision, existing	2 spaces per mobile home or trailer stand
Manufactured home park or subdivision, expansion	2 spaces per mobile home or trailer stand
Manufactured home/modular home sales	1 space per 400 square feet of building gross floor area
Manufactured/Mobile Home; RV Dwelling	See Dwelling, Single Family
Manufacturing, extractive, non-urban	1 per 300 square feet of building gross floor area; plus, 1 space per vehicle used in conjunction with the business
Manufacturing, extractive, urban	1 per 200 square feet of building gross floor area; plus, 1 space per vehicle used in conjunction with the business
Manufacturing, heavy	1 space per 350 square feet of office area, plus, 1 space per 1,700 square feet of other building gross floor area
Manufacturing, light	1 space per 350 square feet of office area; plus, 1 space per 1,700 square feet of other building gross floor area
Marina	1 space per 300 sq. ft. of building gross floor area
Massage parlor	1 space per 400 square feet of building gross floor area; plus, 1 space for each therapy room
Mechanical rides or attractions	1 space per three thousand (3,000) square feet of outdoor active recreation space, plus, any additional spaces required for ancillary uses such as, but not limited to, game centers, theaters and billiard halls.
Medical clinic	1 space per exam room; plus, 1 space per 400 square feet of building gross floor area

White County Zoning Ordinance Parking and Loading Standards

Use Category	Minimum Parking Requirements
Medical Emergency/Immediate Care Facility	1 space per exam room; plus, 1 space per 400 square feet of gross floor area
Medical, Mental Health Facility (or Psychiatric Hospital)	1 space per 4 beds; plus, 1 space per 400 square feet of gross floor area
Medical office	1 space per 400 square feet of building gross floor area; plus, 1 space for each exam room
Meterological tower	None
Miniature golf facility	1; plus, 1 spaces per golf hole
Model home or apartment	2 spaces (per residential standards)
Modular home	2 spaces (per residential standards)
Motel	1 space per 400 square feet of general office and maid floor area; plus, 1 space per sleeping room
Motorcycle sales	See "Automobile sales"
Museum/gallery	1 space per 250 square feet of exhibit area
Neighborhood facility	1 spaces per 200 sq.ft. of building gross floor area
Newspaper publishing	1 space per 400 square feet of building gross floor area
Newspaper stand	None
Non-profit/charitable organization	1 space per 400 square feet of building gross floor area
Nursery, horticultural	1 space per 400 square feet of building gross floor area
Nursing home	1 space per 3 sleeping rooms; plus, 1 space per 1,000 square feet of building gross floor area
Office Building	1 space per 300 square feet of building gross floor area..
Office research park	3 spaces per 1,000 sq.ft. of building gross floor area up to 20,000 sq.ft.; plus, 2 spaces per 1,000 sq.ft. of building gross floor area greater than 20,000 sq.ft.
Orchard/Vineyard	1 space per 400 square feet of building gross floor area

White County Zoning Ordinance Parking and Loading Standards

Use Category	Minimum Parking Requirements
Outdoor storage	See "Storage, Outdoor)
Park, private or public	Requirements as provided in Section 8.11.5
Parking lot	As designed
Parking lot event, special	None
Parking structure	As per the structure's site plan
Peddler	See "Sidewalk vendor"
Personal/Professional Services (includes social services)	1 space per 350 square feet of building gross floor area
Petting zoo	None
Pole barn	2 spaces per barn when it is the lone structure on the lot; otherwise none.
Printing, lithographing, publishing or photography	1 space per 400 square feet of building gross floor area
Race track	1 space per 4 seats at maximum capacity
Radio, TV, music studio/station	2 spaces; plus, 1 space per 400 square feet of building gross floor area.
Railroad facilities	1 space per 400 square feet of building gross floor area
Raising and breeding of non-farm fowl or animals, commercial	None
Recreational facility, indoor	1 space per 4 seats or 1 space per 4 people at maximum capacity (whichever is greater)
Recreational facility, outdoor	If not delineated specifically, 30 per playing field or 1 space for each 4 guests at peak capacity.
Recreational vehicle park	1 space per 150 sq ft of office space, plus, 2 loading spaces.
Recreational vehicle sales	1 spaces per 400 sq.ft. of building gross floor area; plus, 2 spaces per service bay.
Recycling facility	1 space per 400 square feet of building gross floor area; plus, 1 space for each vehicle used in the operation of the business

White County Zoning Ordinance Parking and Loading Standards

Use Category	Minimum Parking Requirements
Recycling satellite, private	1 loading/unloading space per container
Recycling satellite, public	1 loading/unloading space per container
Refinery, petroleum	1 space per 400 square feet of building gross floor area
Religious institution	1 space per 4 seats in main auditorium
Rendering plant	See "Manufacturing, Heavy)
Residential subdivision	As required by approved plat
Resort	1 space per 300 square feet of general office and maid floor area; plus, 1 space per sleeping room
Restaurant	One (1) parking space for each 50 square feet of building gross floor area; plus, one (1) space for each (100) square feet of outdoor dining and entertainment area.
Restaurant, drive-thru	1 space per 300 sq.ft. of building gross floor area
Retail establishment (0 to 99,999 gsf)	1 space per 150 sq.ft. of building gross floor area
Retail establishment (100,000 gsf or more)	1 space per 150 square feet of building gross floor area
Retail, temporary	None
Retreat	Requirements as provided in Section 8.11.5
Sales office/dwelling unit	See Home Occupation
Sawmill	1 space per employee on the largest shift
Scrap metal yard	1 space per 400 square feet of building gross floor area
Sewage treatment plant, private	1 space per 400 square feet of building gross floor area
Shooting range, indoor	1 space per 400 square feet of building gross floor area plus, 1 space per 3 shooting stalls/positions
Shooting range, outdoor	1 space per 400 square feet of building gross floor area plus, 1 space per 3 shooting stalls/positions

White County Zoning Ordinance Parking and Loading Standards

Use Category	Minimum Parking Requirements
Sidewalk vendor/peddler	None
Slaughter house	1 space per 400 square feet of building gross floor area
Solar engery system	None
Solar farm	None
Sporting event	None
Stable or boarding, commercial	1 space per 400 square feet of building gross floor area
Stable or boarding, private	1 space per 400 sqaure feet of building gross floor area
Stadium/coliseum/athletic field, commercial	1 space per 2 seats of spectator capacity
Stockyard	Requirements as provided in Section 8.11.5
Storage, commercial boat (See Boat Storage, Commercial)	
Storage, bulk	None
Storage, commercial	None.
Storage facility, self service	1 ADA space for each two required ADA accessible units
Storage, outside	None
Storage, personal	2 spaces when not associated with a residential dwelling
Storage tank, fuel (commercial)	1 space for maintenance
Storage tank, fuel (private)	none
Storage tank, gas (commercial)	1 space for maintenance
Storage tank, gas (private)	None
Storage tank, oil (commercial)	1 space for maintenance
Storage tank, oil (private)	None
Storage tank, water/water tower	1 space for maintenance

White County Zoning Ordinance Parking and Loading Standards

Use Category	Minimum Parking Requirements
Storage yard	1 space per vehicle at maximum capacity use
Subdivision, residential major	Per subdivision plat
Subdivision, business/industrial	Per subdivision plat
Swimming pools, private	None
Tattoo parlor (see personal/professional services)	
Taxicab Company	1 space per taxicab affiliated with the service; plus, 1 space per 200 square feet of general office area.
Tavern	One (1) parking space for each fifty; (50) square feet of building gross floor area; plus, one (1) space for each two hundred (200) square feet of outdoor dining and entertainment area
Theater, indoor	Requirements as provided in Sections 8.4, 8.5 and 8.11.3
Theater, outdoor	1 space per 400 square feet of building gross floor area; plus, 1 space for each 4 patrons as maximum capacity
Therapeutic horseback riding/equine-assisted activity/adaptive riding	2 spaces; plus, 1 space per animal at maximum capacity
Ticket booth	None
Transfer facility, solid waste	1 space per 400 square feet of building gross floor area
Transfer facility, other	1 space per 400 square feet of building gross floor area
Truck freight terminal	1 space per 400 square feet of building gross floor area
Truck stop	1 space per 300 sq.ft. of building gross floor area
Truck wash	1 space per 400 square feet of building gross floor area
Utility facility, public	1 space per 1,000 square feet of building gross floor area other than office area; plus, 1 space for each vehicle used in conjunction with the facility's use plus 1 space per 200 square feet of general office area.

White County Zoning Ordinance Parking and Loading Standards

Use Category	Minimum Parking Requirements
Utility facility, private	1 space per 1,000 square feet of building gross floor area other than office area; plus, 1 space for each vehicle used in conjunction with the facility's use plus 1 space per 200 square feet of general office area.
Vacation home/holiday home/holiday apartment/tourist home	1 space per bedroom; plus, 1 space for each room where sleeping accommodations are accessible or may be made
Veterinary clinic/hospital	1 space per 400 square feet of building gross floor area
Warehouse	1 space per 400 square feet of building gross floor area
Water and sewage distribution and pumping facilities (For water and treatment plants, see Utility Facility, Public)	None
Water park	1 space per three thousand (3,000) square feet of outdoor active recreation space, plus, any additional spaces required for ancillary uses such as, but not limited to, game centers, theaters, restaurants and billiard halls.
WECS - commercial	None
WECS – Micro	None
WECS – non-commercial (all heights)	None
Welding shop	1 space per 400 square feet of building gross floor area
Wholesale business	1 space per 400 square feet of building gross floor area
Winery	1 space per 300 sq. ft. of building gross floor area
Wireless facility, communications	None
Wireles facility, micro	None
Wireless facility, small cell	None

Use Category	Minimum Parking Requirements
Youth/juvenile detention center	1 space per 400 square feet of building gross floor area excluding area dedicated to holding cells or rooms; plus, 1 space per 3 holding cells or rooms designed for temporary occupancy
Zoo, petting	1 space per 50 sq.ft. of exhibition area
Zoo/zoological garden/zoological park	1 space per 3,000 sq.ft. of total land area

- (1) A facility is allowed to utilize two on-street parking spaces toward satisfying their off-street parking requirement as long as the street abutting the property allows on-street parking and this allowance does not conflict with any other standard or requirement of this Ordinance.
- (2) The following standard shall be used anytime outdoor seating is provided but not accounted for in Table 8.6 above. A parking space allowance for outdoor seating is one parking (1) space for every four (4) outdoor seating positions created by a seat or sixteen (16) inches of bench space.

CHAPTER 9 LANDSCAPING STANDARDS

9.0 PURPOSE AND INTENT

The purpose of this Chapter is to establish minimum standards for the provision, installation and maintenance of landscaping and buffering to increase the compatibility of development with the natural environment and/or physically separate and visually screen adjacent uses and zoning districts that are not fully compatible. All B-1 and B-4 District parcels are exempt from the Standards of this Chapter unless specifically provided for herein.

9.1 APPLICABILITY

Unless otherwise stated, this Chapter shall apply to all public, private, and institutional developments constructed after the adoption of this Ordinance.

9.2 LANDSCAPE PLAN REQUIREMENT

A landscape plan shall be required for proposed developments in the following situations:

- A. Commercial, new development of land;
- B. Commercial, redevelopment of land which includes a rezoning of the property and where the property abuts a non-compatible land use;
- C. Industrial, new subdivisions; or
- D. New, multi-family residential projects.

Site elements such as outdoor lighting, signage, trash receptacles and fencing shall be considered integral parts of a landscape plan. The end result should be a plan, which incorporates a pleasing appearance from both within and looking at the subject site. All landscape plans shall conform to the provisions of this Chapter.

A site shall be considered a "redevelopment" when costs of a project exceed 50% of the assessed value of all land improvements as provided for by the County Assessor's Records.

9.2.1 Preparation

When a landscape plan is required it shall be submitted by the applicant and prepared by an experienced landscape design professional unless, at the discretion of the Executive Director, the required landscape information is provided on a site plan prepared by a professional engineering firm, architect, design company or equivalent professional or professional firm.

9.2.2 Content

All landscape plans submitted for approval as a component of a required site development plan shall show the entire lot drawn to scale and shall contain the following information:

- A. Name and address of the owner, developer, and plan preparer, the date the plan was prepared, scale, and north arrow.
- B. Location and dimensions of all existing and proposed structures, parking lots and driveways, roadways and right-of-ways, sidewalks and other designated pedestrian or bicycle pathways, ground signs, refuse disposal areas, bicycle parking areas, freestanding electrical equipment, man holes, meters, recreation facilities, utility lines and easements, freestanding structural features, any existing trees or shrubs that will be retained and other landscape improvements, such as earth berms, walls, fences, screens, sculptures, fountains, street furniture, lights, and courts or paved areas.
- C. Location, quantity, size, and common name of all proposed planting materials.
- D. Location of barriers to be placed at or beyond the drip line of any trees to be preserved, and the type of material to be used for the barrier.
- E. Planting and installation details as necessary to ensure conformance with all required setbacks.
- F. All drawings shall be at a scale not smaller than one inch equals fifty feet (1"=50') with a scale of one inch equals thirty feet (1"=30') being preferred. Any other scale must be approved by the Executive Director. No individual sheet or drawing shall exceed twenty-four inches by thirty-six inches (24" x 36").

9.3 GENERAL LANDSCAPING REQUIREMENTS

9.3.1 Agricultural Districts

A. A-1 District

An A-1 District utilized for farming, R-1, single family residential use or single and two residential use, shall be considered a base zoning use and shall not be required to have a buffer yard.

B. A-2 District

In any A-2 District, a buffer shall be required for any structure proposed within two hundred (200) feet of a public right-of-way or any non-compatible zoning district. Said buffer shall be installed and planted as prescribed in Table 9.1, Landscape Requirements.

9.3.2 Placement of trees

All plantings shall be setback from the property line as determined by the anticipated drip line of the mature planting. In no instance shall a tree be placed or allowed to grow where the drip line overextends the property line of the property on which it is planted.

9.3.3 Vision clearance areas

In no instance shall a planting obstruct the sight lines between streets and access drives and parking aisles near entries and exits in accordance with the standards provided in Chapter 3, Specific Use Requirements and Performance Standards, Vision Clearance Triangle, of this Ordinance.

9.3.4 Parking lot landscaping requirements

In the event that a new development provides a parking lot section of fifty (50) spaces or more, at least four percent (4%) of the total area of the proposed parking lot shall be used for landscaping and buffering. For Industrial zoning district properties, ie. I-1, I-2 & I-3, parking lot spaces dedicated to employee parking are exempt from the requirement of this sub-section. In addition:

A. Minimum number of plantings

A minimum of one (1) tree shall be planted for every twenty-five (25) parking spaces. Said tree shall be placed in a tree island located within the parking lot. Where no additional buffer is required, there shall be one (1) additional tree, of an ornamental variety, planted every 50 linear feet of parking lot perimeter.

B. Tree islands

Tree islands shall be installed intermittently, or consecutively, to protect plantings from vehicles and foot traffic and to accommodate a tree root system. Said islands shall have a minimum length equal to that of a parking stall, and a minimum width of four (4) feet.

C. Unimproved disturbed ground

All unimproved disturbed earthen areas shall be replanted, restored, or otherwise protected from erosion.

D. Maintenance

All ongoing maintenance, including the replacement of any dead or otherwise unhealthy planting materials, shall be the responsibility of the property owner.

9.3.5 Protection of landscaped areas

All landscaped areas, including tree islands, shall be separated from vehicular traffic movement by a concrete, chair back curb or wheel stops.

A. Curbing

In instances where a curb is used, said curb shall have a minimum height of four (4) inches, measured from the finished surface grade of the parking lot. All tree islands shall be separated from vehicular traffic movement by a curb as described above. Roll curbs are hereby expressly prohibited from use in this application.

B. Wheel stops

In instances where landscaped areas are separated from vehicular traffic movement through the use of wheel stops, said wheel stops shall have a minimum height of four (4) inches, measured from the finished surface grade of the parking lot. All wheel

stops shall be properly anchored and continuously maintained in a good condition. Wheel stops shall not be placed in any location designed for pedestrian circulation.

9.3.6 Screening of outdoor activities

A. Non-residential activities

All non-residential manufacturing, assembling, construction, repairing, and maintenance which take place on a regular basis outside of a primary or accessory structure which is within fifty (50) feet of a public right-of-way or a residential district shall require an approved landscape screen as prescribed by Table 9.1, Landscape Requirements.

B. Outdoor storage

All outdoor storage shall be completely enclosed by a fence with a minimum height of six (6) feet which has an access gate that remains closed and locked except when attended by authorized personnel. With the exception of the access gate, the enclosure shall be screened by plantings on all sides. Said fence and plantings shall meet the following requirements:

1. Fence

The security fence shall be opaque and constructed of a material. Said materials shall be of a color or colors that are compatible with the natural environment.

2. Plantings

Evergreen plant materials shall be located to as to create a dense screen. Said plantings shall reach a mature height of at least six (6) feet.

9.3.7 Screening requirements for wireless communications facilities

A communications tower base and all accessory equipment shall be enclosed by a security fence of at least six (6) feet in height with an access gate that remains locked except when attended by authorized personnel. In addition, the enclosure shall be screened on all sides; and both the fence and screening shall meet the following provisions:

A. The security fence shall be opaque and shall be of a color or colors that are compatible with the natural environment.

B. The screen shall be of dense evergreen plant material with a mature height of at least six (6) feet.

9.3.8 Screening of refuse and recycling areas

Non-residential and multi-family refuse disposal dumpsters shall be screened on three (3) sides by the construction of a permanent opaque wall or fence. Said wall or fence shall be constructed of one (1) or more of the following materials: wood, vinyl, brick, or masonry. Said wall or fence shall be a minimum of six (6) feet in height and a maximum of eight (8) feet in height. The unscreened side shall provide for access to the dumpster and shall be gated. Said gate shall be opaque constructed of one (1) of the following materials: wood, vinyl, or slated chain-link gate. The access gate should be located to

minimize visibility from any public road or right-of-way and maximize accessibility by the property occupant. All access gate locations must be approved by the Executive Director to achieve this balance prior to the issuance of an Improvement Location Permit.

9.3.9 **Screening requirements for service structures**

For the purposes of administering and enforcing this Chapter, service structures in a B-2, B-3, I-1, I-2 or I-3 zoning district shall include, but are not limited to: Propane tanks, electrical transformers, utility vaults which extend above the ground, ground mounted utility equipment and any electrical or other equipment or elements providing service to a building or a site. No service structure shall be visible from an adjacent residential development or public right-of-way. Any service structure that can be seen from the first floor of a residence or from any street shall be screened. Structures may be grouped together; however, screening height requirements shall be based upon the tallest of the structures.

9.3.10 **Detention/retention basins and ponds**

Detention/retention basins and ponds shall be vegetated. While not required, developers are strongly encouraged to shape each pond so that it replicates a natural form, rather than a geometric object, such as a square, rectangle or triangle.

9.3.11 **Preservation**

The minimum number of plantings required by this Ordinance may be modified in any situation where existing trees and vegetation are preserved. A credit for the preservation of desirable undergrowth, shrubs and trees may be awarded on a case-by-case basis at the discretion of the Executive Director or the Area Plan Commission. Such allowance shall be in writing and included as part of the Improvement Location Permit file for the site.

9.4 **APPROVED LANDSCAPING MATERIALS**

Appendix C, Table of Recommended Plant Materials, contains tables that specify the approved trees, shrubs, and ground cover to be used to meet the landscaping and buffering requirements of this Chapter. Plant materials not listed on the tables will be assigned a classification based on height, spread, and/or crown at maturity, using the best available resources to determine mature characteristics. Appendix C should be interpreted as follows:

9.4.1 **Trees**

Trees are grouped into three (3) categories: shade trees, ornamental trees; and evergreens. Trees proposed to meet the requirements of this Chapter may be selected from Appendix C: Table C-1 and Table C-2.

9.4.2 Shrubs and vines

Shrubs are grouped by height: small shrubs (<2'), medium shrubs (2'-6'), and large shrubs (>6'). Shrubs and vines proposed to meet the requirements of this Chapter may be selected from Appendix C: Tables C-3 and C-4.

9.4.3 Ground cover

Except where occupied by planting beds or mulch trails, all buffer areas shall be planted with grass, sod or another comparable ground cover.

9.4.4 Screening materials

Materials used for screening may consist of both natural and man-made objects, provided that said materials create a continuous visual screen. The following screening types may be used:

A. Plant materials

Plant materials shall be characterized by dense growth and shall form an effective year-round screen within three (3) years of the time of planting.

B. Fences and walls

Fences and walls used for screening shall be one hundred percent (100%) opaque (solid) and made of wood, vinyl, or masonry materials. Refer also to Table 9.1, Landscape Requirements.

C. Earthen berms

Earthen berms shall have a maximum slope of 3:1 and a maximum height of ten (10) feet in all zoning districts except I-1, I-2, I-3, A-2 or on any property where extractive manufacturing is conducted, in which case berms shall be allowed to a height of twenty (20) feet. With the exception of a mulch trail, all earthen berms shall be entirely vegetated with an appropriate ground cover within two (2) years of the time of planting.

9.5 INSTALLATION AND MAINTENANCE

All plant materials shall be nursery grown and conform to the requirements described in the latest edition of the American Standard for Nursery Stock, as amended from time to time by the American Association of Nurserymen.

9.5.1 Trees

All trees planted as part of a required landscaping plan shall conform to the following standards and provisions at the time of planting:

- A. Caliper measurements shall be taken six (6) inches above grade for trees under four (4) inches in diameter and twelve (12) inches above grade for trees four (4) inches or larger in diameter.
- B. Minimum branching height for all shade trees shall be four (4) feet.
- C. Minimum size for shade trees shall be two and a half (2 1/2) inches in caliper.
- D. Minimum size for ornamental trees shall be one and one half (1 1/2) inches in caliper
- E. Minimum size for evergreen trees shall be four (4) feet in height.

9.5.2 Responsible party

For the purposes of administering and enforcing this Ordinance, the owner of the property shall be responsible for the maintenance, repair, and replacement of all landscaping materials on the premises. The owner shall further be responsible for ensuring that all landscaped areas are kept free of refuse and debris, and that any fence, wall or barrier that is required by this Ordinance is maintained in good repair.

9.5.3 Dead, dying or damaged plant materials

All plant materials that die shall be replaced with plant materials which conform to the standards of this Chapter within thirty (30) days of the plant material's death. If weather conditions inhibit installation of new plant materials the required landscaping shall be replaced with plant materials which conform to the standards of this Chapter within six (6) months of the plant material's death. Extensions of time may be granted by the Executive Director on a case-by-case basis.

9.6 FENCING

Anyone with the intentions to install a fence whose property is located in a Flood Hazard Area, regardless of zoning district or use, must obtain a permit from the Department of Natural Resources in addition to complying with the requirements of this Section.

Fences are allowed within any zoning district, provided that they are in conformance with the provisions of this Section. When not located in a Flood Hazard Area, fences used in conjunction with farming activities, parks or utilities shall be exempt from these regulations.

9.6.1 Construction materials

Unless otherwise specified by this Ordinance, all fences shall be constructed of wood, vinyl, wrought iron, chain link, stone/rock or masonry materials. In no instance shall a barb wire or electric fence be allowed in a residential district.

9.6.2 Height

Unless otherwise specified in this Ordinance, no fence shall exceed six (6) feet six (6) inches in height as measured from any grade point to the top of the fence or fence structure at that point.

9.6.3 Front yard limitations for residential uses

No fence taller than three and one half (3 ½) feet may be placed between the front of the primary structure, (the side where the address is required to be posted), and the road right-of-way. No fence that is more than fifty percent (50%) opaque may be placed within a front setback buffer. In the case of a lake area property, this front yard limitation applies only to the property lines which abut a road.

9.6.4 Decorative fences for residential uses

Fencing which is intended for decorative purposes only may be allowed on any part of a parcel, provided that it does not exceed three (3) feet in height.

9.6.5 Non-residential fences

1) Fences intended for use in conjunction with a business or industrial operation or for use by a branch of government and not exempted elsewhere in this Section, shall comply with Subsections 9.6.1, 9.6.2 & 9.6.3 of this section except that the fence must not encroach a front setback requirement.

2) Security Fences: Fences in a business (B-1, B-2, B-3 and B-4), industrial (I-1 and I-3) district or used by a branch of government, that are intended for security purposes shall only be allowed under the following conditions:

A. Such fences shall be allowed within a side or rear yard area, but shall be prohibited in a front yard setback;

B. The property owner or occupant must provide to the Executive Director, in writing, a justification of the need for a Security fence;

D. Security fences shall be of common chain link construction and may not be more than fifty (50) percent opaque (other materials may be used upon written approval by the Executive Director if, in the opinion of the Director, such materials are needed to accomplish the security objectives of the property owner or occupant and do not create an unsafe or nuisance condition);

E. Security fences shall not exceed eight (8) foot four (4) inches in height; and,

F. Barbed wire use shall not be allowed.

3) Fences for security purposes in an I-2 district may be placed in a rear, side or required front yard area subject to the following provisions:

- A. The fence is a minimum of fifteen (15) feet from the front property line;
- B. In no instance shall the fence exceed eight (8) feet four (4) inches in height, with the exception of fences with barbed wire. Fences with barbed wire may add up to three (3) strands of barbed wire on top of the fence for a total maximum fence height of eleven (11) feet; and,
- C. Security fences shall be of common chain link construction (other materials may be used upon written approval by the Executive Director if, in the opinion of the Director, such materials are needed to accomplish the security or nuisance objectives of the property owner or occupant) and may not be more than fifty (50) percent opaque

Security fences shall not be allowed in any R-1, R-2, R-3, R-4 or L-1 zoning district except in cases where the property is used by a branch of government.

9.6.6 Municipal Regulations

Any fence constructed on a property located within a City or Town boundary or within the defined limits of Buffalo or Idaville is, in addition to the requirements provided for elsewhere in this Section, required to comply with the following:

- A. Prior to initiating construction of any fence, other than those exempted in Section 9.6, a property owner or contractor must obtain an improvement location permit from the Area Plan Department;
- B. If your property all or partially lies within a Special Flood Hazard Area, you are required to obtain a permit from the Indiana Department of Natural Resources in addition to the local permit required by Subsection 9.6.6 A;
- C. Any fence on a property used for any purpose, other than single or two-family residential purposes, may not place any portion of the fence within a front yard setback unless specifically provided for elsewhere in this Chapter;
- D. Any fence or portion of a fence extending into a front yard setback may not be taller than three and one-half (3 ½) feet tall; and,
- E. No fence or portion of a fence extending into a front yard setback may be more than fifty (50) percent opaque.

Table 9.1: Landscaping Requirements

SUBJECT PROPERTY	MINIMUM WIDTH	LOCATION	REQUIRED PLANTINGS	DISTANCE FOR REQUIRED PLANTINGS
L-1	None	None	None	None
A-1	None	None	None	None
A-2 Applies to confined feeding operations only	20'	Along all lot lines excluding those lot lines abutting an Agricultural or Industrial district and excluding areas designed for ingress/egress access	Two (2) rows of staggered evergreens	One (1) tree every 20' along required property line(s)
RR	None	None	None	None
R-1	None	None	None	None
R-2	None	None	None	None
R-3	Option 1: 30'	Options 1, 2 or 3: Along all side and rear yard lot lines	Option 1: One (1) tree and three (3) large shrubs	Option 1: Every fifty (50) linear feet along required property line(s)
	Option 2: 10'		Option 2: Solid screening at least six (6) tall from Appendix C-3	Option 2: Entire length along required property line(s)
	Option 3: 5'		Option 3: Solid Fence at least six (6)' tall, no more than eight (8)' tall	Option 3: Entire length along required property line(s)
R-4	Option 1: 30'	Options 1, 2 or 3: Along all side and rear yard lot lines	Option 1: One (1) tree and three (3) large shrubs	Option 1: Every fifty (50) linear feet along required property line(s)
	Option 2: 10'		Option 2: Solid screening at least six (6)' tall from Appendix C-3	Option 2: Entire length along required property line(s)
	Option 3: 5'		Option 3: Solid Fence at least six (6) tall, no more than eight (8)' tall	Option 3: Entire length along required property line(s)
PUD	As prescribed by an approved PUD Ordinance			
B-1	As required by the Governing Jurisdiction			
B-2	10'	Along the side and rear property lines, with the exception of lot lines immediately adjacent to a Business, Industrial or Agricultural district, wherein no buffer is required	One (1) ornamental or evergreen tree & three (3) large shrubs; <i>plus</i> a solid eight (8)' privacy fence at the lot line of the rear and side yards when adjoining an "R" or "L" zoning district	Specified plantings: Every fifty (50) linear feet along required property line(s)
B-3	10'	Along the side and rear property lines entire perimeter, with the exception of lot line immediately adjacent to a Business, Industrial or Agricultural district, wherein no buffer is required	One (1) ornamental or evergreen tree & three (3) large shrubs; <i>plus, when adjoining an "R" or "L" zoning district, a solid eight (8)' privacy fence at the rear of the buffer area.</i>	Specified plantings: Every fifty (50) linear feet along required property line(s)
B-4	None			
	Option 1: 20'	Option 1 or 2: Along all side and rear yard lot lines, with the exception of lot lines immediately adjacent to another Industrial or	Option 1: Minimum eight (8) evergreen trees, and five (5) large shrubs; <i>plus, when adjoining an "R" or "L" zoning district, a solid eight (8)' privacy fence at the rear of the buffer area.</i>	Specified plantings: Every fifty (50) linear feet along required property line(s)

I-1	Option 2: 40'	Agricultural district, wherein no buffer is required	Option 2: Minimum four (4)' berm with one (1) shade tree, two (2) evergreen trees and ten (10) large shrubs; <i>plus, when adjoining an "R" or "L" zoning district, a solid eight (8)' privacy fence at the rear of the buffer area.</i>	
I-2	Option 1: 20'	Option 1 or 2: Along all side and rear yard lot lines, with the exception of lot lines immediately adjacent to an Industrial or Agricultural Industry (A-2) district, wherein no buffer is required	Option 1: Minimum eight (8) evergreen trees, and five (5) large shrubs; <i>plus, when adjoining an "R" or "L" zoning district, a solid eight (8)' privacy fence at the rear of the buffer area.</i>	Specified plantings: Every fifty (50) linear feet along required property line(s)
	Option 2: 40'		Option 2: Minimum four (4)' berm with one (1) shade tree, two (2) evergreen trees and ten (10) large shrubs; <i>plus, when adjoining an "R" or "L" zoning district, a solid eight (8)' privacy fence at the rear of the buffer area.</i>	
I-3	Option 1: 20'	Option 1 or 2: Along all side and rear yard lot lines, with the exception of lot lines immediately adjacent to an Industrial or Agricultural Industry (A-2) district, wherein no buffer is required	Option 1: Minimum eight (8) evergreen trees and five (5) large shrubs; <i>plus, when adjoining an "R" or "L" zoning district, a solid eight (8)' privacy fence at the rear of the buffer area.</i>	Specified plantings: Every fifty (50) linear feet along required property line(s)
	Option 2: 40'		Option 2: Minimum four (4)' berm with one (1) shade tree, two (2) evergreen trees and ten (10) large shrubs; <i>plus, when adjoining an "R" or "L" zoning district, a solid eight (8)' privacy fence at the rear of the buffer area.</i>	

No Principal or Accessory structures shall be allowed in a required buffer zone, other than fences.

CHAPTER 10 SIGN STANDARDS

10.0 PURPOSE AND INTENT

10.0.1 Purpose

The purpose of this Chapter is to regulate the size, height, construction, maintenance, limitations, restrictions and permit status of all outdoor signage. These regulations are required to assure the health, safety, convenience and general welfare of the public; to create an attractive and harmonious community; to protect property values; and to further the community's economic development objectives. All signs required by a compelling governmental interest are exempt from these standards. In an AED district, only a sign classified as a Ground Sign, Pole Sign, Electronic Messaging Sign, Multiple Entity Sign or ADA sign are subject to the regulations and permitting requirements of this Chapter.

10.0.2 Intent

It is the intent of these regulations to promote signs that are:

- A. Legible and appropriate to the activity to which they pertain;
- B. Not distracting to motorists or boaters so as to create a safety hazard;
- C. Constructed and maintained in a structurally sound and attractive condition; and,
- D. Preserving and enhancing the character and visual appearance of White County.

10.1 SIGN PERMITS

10.1.1 Sign permit requirement

Except as otherwise provided herein, all signs regulated by this Ordinance shall require a permit issued by the Staff. A sign permit shall not be required for a change in the face of a sign as long the new sign face is the same size or smaller than that of the replaced sign, located within the envelope of the replaced sign and is of comparable construction type.

10.1.2 Information required for sign permit

All applications shall be submitted to the Staff and shall be accompanied by any information the Staff determines is necessary to assure compliance with this Ordinance. This includes, but is not necessarily limited to, the following:

- A. A site plan, with descriptions showing the location of the sign which is the subject of the permit. The site plan shall also show the location of all existing and anticipated free-standing signs on the same property;
- B. Where applicable, certification that the proposed sign meets the standards specified in the National Electrical Code adopted by the State of Indiana, Underwriters Laboratory or equivalent lab or code standard. This

requirement may be waived by the Executive Director for signs which are pre-manufactured for promotional purposes, designed for wall mounting and are less than four (4) square feet in size (such as those used by bars and taverns);

- C. A drawing, sketch or picture showing the size and dimensions of the sign face, the sign content, the overall height and width of the sign including the sign structure. along with installation details both of the sign to it's supporting structure and the sign structure to the ground (if applicable).
- D. A description of the sign material;
- E. Method and type of illumination, when applicable;
- F. Mounting details, which must include the method and installation details of mounting the sign to its supporting structure along with installation details and how the structure will be secured in the ground (if applicable).

10.1.3 **Permit fees**

When required, all application fees shall be filed with the Area Plan Commission Staff as specified by the Official Fee Schedule. If any sign is hereafter erected, placed, installed or otherwise established on any property before obtaining a permit as required herein, it shall be considered a civil zoning violation of this Ordinance and subject to enforcement by the Staff.

10.1.4 **Expiration of permit**

A sign permit shall become null and void if installation of the sign has not been completed within six (6) months from the date the permit is issued. Any applicant who fails to complete their sign installation within the time period specified above must apply for a new permit. The permit tag must be properly mounted within seven (7) days from the date the sign installation is complete. Failure to properly mount the permit tag will be considered a civil zoning violation.

10.1.5 **Effect of sign permit issuance**

No permit for a sign issued hereunder shall be deemed to constitute permission or authorization to erect or maintain an unlawful sign, nor shall a permit issued hereunder constitute a defense in an action to abate an unlawful sign.

10.1.6 **Permit revocation**

The Executive Director is empowered to revoke a sign permit in the event that any of the following circumstances exist:

- A. A sign is being constructed or installed without any other permit required by this Ordinance; and/or,
- B. A sign is being constructed in violation of:
 - 1. The terms, conditions, or provisions of this Ordinance;
 - 2. The terms, provisions conditions, or commitments of a variance; and/or,

3. The terms, provisions, conditions, or commitments of a special exception use permit.

The stop work order shall be posted in a conspicuous place on the property on which the violation is located or occurring, or personally delivered to the owner, occupant, tenant or person in charge of the property.

10.2 GENERAL REQUIREMENTS FOR ALL SIGNS

The regulations of this Section are in addition to the district regulations imposed on individual sign types in a given district.

10.2.1 Display of permit

Each sign permit tag shall be permanently attached to the sign or mounting structure so as to be visible from the road unless an alternate location has been approved by the Staff.

10.2.2 Responsibility

The owner and/or tenant of the premises and the owner and/or erector of the sign shall be held responsible for any violation of these regulations.

10.2.3 Maintenance

All signs shall be maintained in good condition and appearance as determined by the Executive Director or Office Administrator. Lights for illuminated signs shall be maintained in good working order.

10.2.4 Removal

The Executive Director shall remove or cause to be removed, at the owners' expense, any sign erected or maintained in conflict with these regulations. Removal of a sign by the Executive Director shall not affect any proceedings instituted prior to removal of such sign. See Section 10.5.2 of this Chapter for removal details.

10.3 GENERAL SIGN REGULATIONS

The regulations of this section apply to all signs whether or not a permit is required and may not be deviated from without approval from the Area Board of Zoning Appeals or else as expressly allowed in this section.

10.3.1 Location

- A. No sign or sign structure shall be placed on private property without the written consent of the owner or agent thereof;
- B. No sign shall be placed on a utility easement or drainage easement, highway right-of-way or railroad right-of-way unless expressly allowed in this Chapter or by State or Federal law, rule or regulation;
- C. No sign or sign structure, other than official street or highway signs, shall be placed upon, over, or in any public right-of-way, unless expressly allowed in this Chapter;

- D. No sign or sign structure shall be erected at any location where it may interfere with, obstruct the view of, or be confused with any authorized traffic sign, signal or device. No sign or sign structure shall be located in such a manner as to materially impede the view of any street or highway intersection, or in such a manner as to materially impede the view of the intersection of a street or highway with a railroad grade crossing. See Chapter 3, Specific Use Requirements and Performance Standards, for requirements for visibility clearance areas at all intersections;
- E. No sign shall be permitted which is placed on any curb, sidewalk, post, pole, bollard, electrolier, hydrant, bridge, tree or other surface located on public property or in a public right-of-way, unless expressly allowed in this Chapter;
- F. No sign shall be attached to any utility pole or any other unapproved supporting structure unless expressly allowed in this Chapter;
- G. No sign structure shall be allowed to provide more than two sign faces unless specifically provided for elsewhere in this Ordinance or unless authorized by the Area Board of Zoning Appeals.

10.3.2 Sign projection

- A. All projection signs require a sign permit from the Area Plan Department;
- B. With the exception of wall signs, no sign shall project over a public right-of-way without express written permission of the County Commissioners, appropriate legislative body or unless expressly allowed in this Chapter. All such signs shall meet the developmental standards required for projection signs and require a permit unless expressly exempted from the permit requirement elsewhere in this Chapter;
- C. Awnings, canopies, marquees and projection signs shall be a minimum of eight (8) feet above any walkway and may not project more than two (2) feet above any roofline. No sign that is affixed to or painted upon the surface of an awning, canopy or marquee shall extend vertically or horizontally beyond the limits of the awning, canopy or marquee.

10.3.3 Movement or simulated motion

- A. No rotating beam, beacon or flashing illumination resembling any emergency light shall be used in connection with any exterior sign display;
- B. No utilization of any motion picture, laser or visual projection of moving images or copy unless expressly allowed elsewhere in this Chapter (for electronic messaging, see the Electronic Messaging subsection under Section 10.4);
- C. Changeable copy elements may be allowed as a component of any sign.

10.3.4 Prohibitions

- A. No sign shall make use of words, phrases, symbols or characters in such a manner as to interfere with, mislead or confuse motorists;

- B. No sign shall bear or contain statements, words or pictures which would violate the standards and definitions provided in IC 35-49-2-1, as amended from time to time;
- C. No sign shall contain advertising matter that is untruthful or misleading.

10.3.5 Emmissions

Signs which emit audible sound or visible matter are prohibited unless authorized by the Area Board of Zoning Appeals or elsewhere in this Chapter.

10.3.6 Visual impairment

Signs shall not hide or block any traffic or roadway sign, signal or device from view except in those circumstances where the Indiana Department of Transportation, county highway, a municipality street department, a public utility or a public emergency services organization authorize such blockage or hiding.

10.3.7 Obstruction

Signs shall not obstruct any door, fire escape, stairway or any opening intended to provide ingress or egress to any structure.

10.3.8 Prohibitions – State or Federal law or regulation

No sign shall be allowed which is in violation of any Federal or State law or regulation.

10.3.9 Sign Components

Any sign subject to a permit may be divided into two components or sections; one component/section which is fixed in face design and one which is variable to allow timely community notices or promotional messages. Each component must be defined at the time the application for permit is submitted.

10.4 ILLUMINATION

All illuminated signs shall comply with the illumination provisions of this Section.

10.4.1 National standards

All illuminated signs must meet the standards specified in the National Electrical Code adopted by the State of Indiana, as amended from time to time, or be certified by UL or equivalent lab certification.

10.4.2 Condition

The total number of illuminating elements shall be kept in satisfactory working condition or immediately repaired or replaced.

10.4.3 Reflection

The direct, non-reflected light from a primary light source shall not create a safety or traffic hazard.

10.4.4 Shielding

- A. The light from any illuminated sign shall be so shaded, shielded or directed that the light intensity or brightness will not be objectionable to the surrounding areas. No light shall shine directly onto adjacent property.
- B. No sign within fifty (50) feet of a residential district shall be illuminated unless the sign is visibly obstructed from view from said residential district. This restriction shall not apply to signs identifying residential subdivisions or multi-family developments. Signs for institutional uses in residential districts may be illuminated if they meet all the standards, regulations and conditions provided for in this Chapter.

10.4.5 Electronic Messaging (EM)

Portable and temporary electronic messaging signs are prohibited except in cases of utilization by a government agency or utility where safety, warnings or hazardous conditions are being conveyed.

Signs in commercial or industrial districts, where not prohibited elsewhere in this Chapter, may utilize electronic messaging, either alone or as a component of a larger sign as long as the sign meets all other standards, regulations and provisions of this Chapter as well as the standards below:

- A. Electronic messaging is not permitted in any residential district unless used for institutional or government purposes or unless authorized by the Area Board of Zoning Appeals.
- B. No flashing, strobing, scintillating or variance of light intensity effects is allowed if the effect takes place more than two (2) times per second.
- C. The design of the copy cannot be created in such a way as to be a distraction to motorist.
- D. Each message on the sign must be displayed a minimum of five (5) seconds.
- E. No electronic messaging may exceed a brightness level of three (3) foot candles above ambient light as measured using a foot candle meter or one hundred (100) feet from the sign face, whichever is least restrictive.
- F. The leading edge of any sign or portion of a sign using electronic messaging shall be a distance of one hundred (100) feet from any abutting residential zoning district.
- G. Any sign within five hundred (500) feet of a residential district or property used in any other district for residential purposes (does not apply to residences in a B-1 or B-4 districts) must be oriented so that the face of the sign runs parallel to the road.
- H. Any change of message must be accomplished immediately (point five (.5) seconds or less).

- I. The face of the sign shall be limited to one advertising message per duration of the display.
- J. No two EM signs may be any closer than one hundred (100) feet as measured from the centerline of each sign. Signs may be placed closer than one hundred (100) feet, if in the sole discretion of the Executive Director, such proximity will not create a nuisance, safety hazard or be distracting to pedestrians or the general neighborhood.
- K. No EM sign may be any closer than one hundred fifty (150) feet to any traffic signal as measured in a straight from the center line of the sign to the centerline of the closest traffic signal fixture.
- L. No EM shall be placed closer than three hundred (300) feet to the closest corner of any residential dwelling unit (excluding those in a B-1 or B-4 district).
- M. Operational limitation: Sign message displays shall be limited to static displays. Apparent motion of the visual message, caused by, but not limited to, the illusion of moving objects, moving patterns or bands of light, expanding, contracting or rotating shapes or similar animation effects shall be prohibited. Such restrictions apply to “traveling”, “scrolling” or “running” messages. No message may appear/disappear via a fade or dissolve effect. Full motion video or film display via an electronic file imported into the EM sign software or streamed in real time to the EM sign is prohibited. All EM Signs shall have automatic dimming controls either by photocell or via software settings, in order to bring the EM sign lighting level appropriate for usage. Each EM sign that is malfunctioning shall be turned off until such time that the sign is properly functioning. The design of the copy cannot be created in such a way as to be a distraction to motorists.

10.5 MAINTENANCE AND REMOVAL

10.5.1 Inspection

Signs may be inspected periodically by the Executive Director and/or his or her agent to ensure compliance with this and other ordinances of the County.

10.5.2 Removal of signs

The Executive Director may order the immediate removal of any sign erected or maintained in violation of this Chapter. The Executive Director may remove a sign immediately and without notice if, in his or her opinion, the condition of the sign is such as to present an immediate threat to the safety of the public. The owner shall pay all costs incurred by the County for removal and storage. Any sign removed by the Executive Director and/or his or her agent pursuant to the provisions of this Chapter shall be held by the County for redemption by the Owner for a period of ten (10) days, at which time the County shall dispose of it in any manner deemed necessary.

Any yard or disposable sign not having obtained proper permitting and which does not include an entity name, phone number and address maybe removed

immediately and without notice. Such signs will be held at the Area Plan Office for seven (7) days and available for pick-up by the sign owner or any other person associated with the signs advertising activity. After seven (7) days all such signs shall be disposed of in an appropriate manner.

10.5.3 **Maintenance**

All signs and components thereof shall be kept in good repair and in a safe, neat, clean and attractive condition. Failure to comply as determined by the Executive Director shall cause the sign to be subject to appropriate enforcement provisions.

10.5.4 **Abandoned signs**

Abandoned signs shall be removed in a time frame and as directed by the Executive Director at the sign and/or property owners' expense.

10.6 **DETERMINING THE MEASUREMENTS OF A SIGN**

The following standards and provisions shall apply to the measurement of any sign.

10.6.1 **Sign area**

The sign area shall be that area which is enclosed by the smallest circle, triangle, or rectangle that can be used to enclose all sign elements, excluding the supporting structure if said structure does not form a part of the sign face or the display. See an example in Figure 10.1, Determining the Measurement of a Sign. Where matter is displayed in a random manner without organized relationship of elements, or where there is reasonable doubt about the relationship of elements, each element shall be considered to be a single sign.

10.6.2 **Back-to-back signs**

Sign faces placed back-to-back, on a single structure, at an angle of fifteen (15) degrees or less, and not more than forty-two (42) inches apart, qualify as back-to-back signs. The sign area for back-to-back signs shall be computed by the greatest sign area of the largest sign face. Back to back signs shall be considered a single sign.

10.6.3 **Sign height**

The height of a sign shall be the distance measured from the average surface grade surrounding the base of a sign to the top of the highest element of the sign. If, at the discretion of the Executive Director, there is a significant difference between road grade and ground grade, the Executive Director may deviate by up to 20% of the allowable sign height.

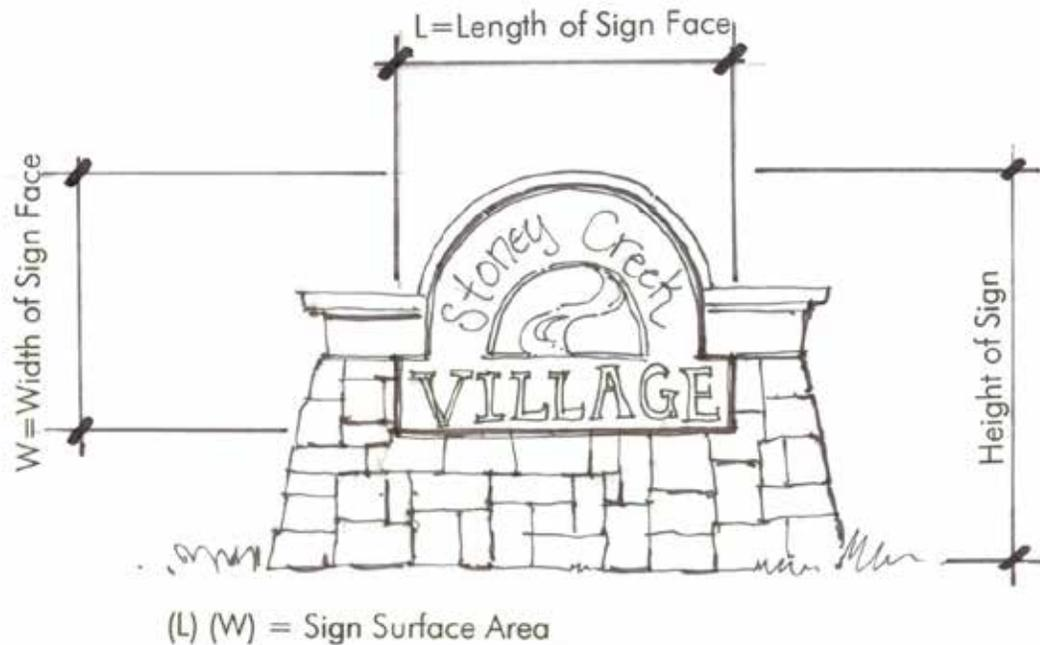

10.7 SIGN STANDARDS FOR RESIDENTIAL ZONING DISTRICTS

10.7.1 Applicable districts

The sign standards of this Section shall apply to all residential zones designated by this Ordinance.

10.7.2 L-1, R-1, R-2 & R-4 Residential Districts Used For Single Family Dwelling or Two Family Dwelling Purposes

A. General Sign Allowance

Each property meeting the criteria of 10.7.2 shall be provided a general sign allowance of forty-eight (48) feet, accumulative, subject to the following conditions and restrictions:

- 1) No individual sign may exceed six (6) square feet;
- 2) No sign may be placed in a legal rights-of-way;
- 3) No sign structure or sign-sign structure in combination may exceed six (6) feet in height;
- 4) No sign shall be illuminated, internally or externally;
- 5) No sign may be placed in a visual clearance area; and,
- 6) Each sign complies with the general sign regulations of this Ordinance and the specific sign regulations applicable to the sign type utilized.

Permanent or non-permanent off-premise signs are not permitted in these residential district & use combinations unless expressly allowed elsewhere in this chapter.

B. Permanent Identification Signs (Gateway Signage)

Any Major Subdivision or Manufactured Home Park is entitled to place no more than two (2) Permanent Identification Signs; also known as Gateway Signage, for any Subdivision or Manufactured Home Park subject to the following restrictions and conditions:

- 1) Each sign must meet all general sign regulations of this Ordinance and the specific sign regulations applicable to the sign type utilized as provided for in Table 10.1;
- 2) No sign may be illuminated in any fashion with the exception of exterior illumination directed at the sign face and in a manner which does not create a nuisance for pedestrian or vehicular traffic or an abutting property owner; and,
- 3) No sign may be placed in a visual clearance area.

10.7.3 R-3 & R-4 Residential Districts Used For Multi-Family Dwelling Units or Manufactured Home Park Purposes

General

A. General Sign Allowance

Each unit on a property meeting the criteria described in 10.7.3 shall be provided a general sign allowance of forty-two (42) feet subject to the following conditions and restrictions:

- 1) No individual sign may exceed six (6) square feet, unless expressly allowed elsewhere in this Ordinance;
- 2) No sign may be placed in a legal rights-of-way;
- 3) No sign structure or sign/sign structure in combination may exceed six (6) feet in height;
- 4) No sign shall be illuminated, internally or externally;
- 5) No sign may be placed in a visual clearance area; and,
- 6) Each sign complies with the general sign regulations of this Ordinance and the specific sign regulations applicable to the sign type utilized.

Permanent or non-permanent off-premise signs are not permitted in these residential districts & use combinations unless expressly allowed elsewhere in this chapter.

The sign allowance provided for in Subsection 10.7.3 B. following, is in addition to the signage allowance provided for in Subsection 10.7.3 A. above.

10.7.4 All Residential Districts Used For Institutional Purposes

In all residential districts used for institutional purposes, sign allowances, regulations and standards will be commensurated with those provided for Commercial and Industrial purposes but which must also meet any additional restrictions, regulations and standards expressly provided for elsewhere in this Chapter.

Table 10.1 – Permanent Identification Sign Regulations for All Residential Districts

Sign Type	Standards			
	Maximum Number of Signs	Maximum Sign Area (square feet)	Maximum Height (feet)	Setback From Right of Way to leading edge of sign (feet)
Ground Signs	2 per 20,000 square feet of parcel area	150	6	10
Wall Signs	1 per building per entrance	40; for home occupations see restrictions in Zoning Ordinance Section 3.1.2 F	Shall not exceed beyond the roofline	N/A
Pole Signs	1 per 20,000 square feet of parcel area	90	25	10

10.8 STANDARDS FOR COMMERCIAL AND INDUSTRIAL ZONING DISTRICTS

10.8.1 Applicable districts

The sign standards of this Section shall apply to all commercial and industrial zoning districts designated by this Ordinance for the specified sign types. Other sign types may be used when provided for elsewhere in this Chapter.

Table 10.2 – Sign Regulations for Commercial and Industrial Districts

Permitted Signs	Maximum Number of Signs	Maximum Sign Area (square feet)	Maximum Height (feet)	Setback From Right of Way to leading edge of sign or sign structure , whichever is most restrictive (feet)	Other Limitations
<p>Wall Signs Including Awning, Canopy and Marquee Signs</p> <p>NOTE: See below for requirements specific to I-3 Districts</p>	Not Applicable	Not Applicable	Shall not exceed 2 feet beyond the roofline or extend past any side or bottom wall perimeter	Not Applicable	No sign shall be allowed if, at the discretion of the Executive Director, it would create a nuisance to a residential district. If the sign extends more than 3” from the mounting surface it must be placed a minimum of 8’ above grade.
<p>Ground Signs</p>	1 per parcel plus one additional sign per each 200’ of parcel road frontage	150	8	10	See above

Pole Signs *	1 per parcel plus one additional sign per each 200' of parcel road frontage	90	25	10	See above
Electronic Messaging Signs	1 per parcel plus 1 additional sign per each 200' of parcel road frontage	100	Maximum height shall be restricted based on the sign type.	Setbacks shall be applied based on the sign type.	Must satisfy all requirements applicable to Electronic Messaging Signs found elsewhere in this Ordinance
Vehicle or Trailer Signs	1 on each hood, trunk or roof or side vehicle surface; 1 on each trailer surface other than the under surface	16 per sign	No more than 2 feet above the roof surface	Not Applicable	Applies only in cases not exempted in Section 10.12
Multiple Entities	1/300 feet Measured radially	60 per sign face; 1 sign face per Entity	40	10	See above
Roof Signs	Per BZA Approval	Per BZA Approval	Per BZA Approval	Per BZA Approval	Only permitted with approval from the Area Board of Zoning Appeals

NOTE: All commercial and industrial signs can be divided into two sections to allow accommodation of one permanent sign component and one replaceable sign component as long as the construction and sign type meet the standards, regulations and provisions of this Chapter and the replaceable component is utilized to promote or make the public aware of community activities or achievements.

* Poles signs may be placed within a vision clearance triangle and long as the sign meets the setback provisions listed in Table 10.2, no part of the physical sign falls within the visual clearance area, each pole would fit within a six (6) inch diameter envelope and, in the sole opinion of the Executive Director, neither the sign nor the sign structure will create a nuisance or safety hazard.

Limitations:

- A. Any sign which is illuminated or which uses accessory illumination must comply with all lighting and illumination standards found elsewhere in this Chapter.
- B. Multiple entity signs may only advertise, promote or identify entities which are located on the common parcel of land as that of the sign.

10.8.2 I-3

- A. In any I-3 District, wall signs must meet the following requirements:
 - 1. All Wall signage, excluding incidental signage necessary for the customer, visitor, vendor or traffic management of the site, must be incorporated into the building façade and are restricted to the portion of the building which faces a public right-of-way;
 - 2. Wall signage may not be painted directly onto the building elevation;
 - 3. Wall sign designs shall be consistent in style and scale with its associated structure; and
 - 4. Individually illuminated channel letters are preferred, back-lit internally illuminated box signs are not allowed.

10.8.3 Shared advertising signs

- A. Shared advertising signs (see Figure 10.2) shall comply with the State of Indiana Advertising Control Manual, as amended from time to time.

Figure 10.2 - Shared Advertising Sign

10.8.4 Roof Signs

A. Standards

Roof signs are allowed only upon the applicant's demonstration to the Board of Zoning Appeals that:

1. The roof signage is necessary due to alternative signage not being adequate to serve the advertising needs of the establishment requesting the sign;
2. The applicant provides sign installation and mounting details which the Board deems to be reasonably safe and secure (engineering certification may be required); and,
3. The applicant provides convincing evidence that the sign will not create a visual nuisance or distraction to neighboring properties or passing vehicular or pedestrian traffic.

B. Limitations & Restrictions

1. Roof signs may not be electrical nor utilize any electronic, LED or similar type components;
2. May not be lighted by any internal or external source; and,
3. May not be located so that any edge or component of the sign is any closer than one foot to any roof peak, valley or edge.

10.9 OFF-PREMISE SIGNS

10.9.1 State permitting compliance

Off-premise signs and billboards located along an Interstate, Federal-aid Primary Highway as it existed on June 1, 1991, or any other highways that are on the National Highway System, must meet the regulations specified in the “State of Indiana Outdoor Advertising Control Manual” as amended from time to time (See IAC 7-3-5 Territory to which article applies), **in addition to** the requirements provided for in this Ordinance.

10.9.2 Billboards, Location

A. Prohibitions

Traditional billboards are expressly prohibited in the following locations:

1. Within the corporate limits of the City of Monticello;
2. In any I-3 zoning district;
3. On any parcel abutting US Hwy 24 between County Road 1200 W and 1000 W in Princeton Township, White County, Indiana; and,
4. Within one thousand (1,000) feet of the US Hwy 24 ROW between County Road 1200 W and 1000 W in Princeton Township, White County, Indiana.

Digital billboards are expressly prohibited in the following locations:

1. Within the corporate limits of any White County Municipality or within one thousand (1,000) feet of any corporate municipality line;
2. Within the defined limits of Buffalo or Idaville as delineated on the County GIS mapping system or within one thousand (1,000) feet of their defined limits;
3. On any parcel abutting US Hwy 24 between County Road 1200 W and 1000 W in Princeton Township, White County, Indiana; and,
4. Within one thousand (1,000) feet of the US Hwy 24 ROW between County Road 1200 W and 1000 W in Princeton Township, White County, Indiana.

Billboards may be allowed in any A-1, A-2, B-2, B-3, I-1 or I-2 zoning district, provided they meet the specifications and requirements of this Chapter and are outside the boundary of any of the prohibited areas described above.

10.9.3 Billboards, Spacing and Size, Lighting

A. Sign spacing

No billboard shall be placed closer than one thousand (1,000) feet to any other billboard. This distance is to be measured radially from the center of the sign.

B. Total sign area

The area for any billboard shall be a minimum of three hundred (300) square feet and a maximum of four hundred fifty (450) square feet per advertising sign face. All extensions to the sign or any advertising message or copy on the sign structure shall be included as part of the sign's total area.

C. Sign height

The maximum height of any billboard shall be forty-five (45) feet as measured from grade to the top of the sign or sign structure, whichever provides the greatest height.

D. Separation from other uses

The minimum distance between any billboard and any residential district, public institution, school or church shall be one thousand (1,000) feet measured radially from the center of the sign.

E. Illumination

Lighting for all billboards shall be internal or external and directed against the sign surface only.

F. Visual clearance

All billboards shall comply with the visibility clearance area provisions in Chapter 3, Specific Use Requirements and Performance Standards.

10.9.4 Billboards, Digital

Any digital billboard or billboard using LED or similar technology or any billboard depicting or using motion lighting must receive approval from the Area Board of Zoning Appeals prior to a sign permit being issued or initiation of construction.

10.9.5 Yard signs (off-premise only)

- A. A sign permit is required for all off-premise yard signs (a group of signs may be authorized under a single permit if they are identical in size and face). Fee will be based on volume.
- B. Yard signs shall not exceed six (6) square feet in sign area and five (5) feet in sign height and shall not be placed closer than fifty (50) feet to any other off-premise yard sign on the same parcel.
- C. All yard signs must display the permit number, the date the permit is issued, name of the business, the physical address of the business and a valid phone number for each sign attaching this information utilizing a permanent method of attachment. Date characters are to be a minimum of one-half (1/2) inch in height and a minimum of one-sixteenth (1/16) inch in character width.

- D. Yard signs shall be located in a reasonable and safe manner as determined by the Executive Director;
- E. Yard signs must be maintained and kept in good repair and must meet the construction/design standards provided in this section.
- F. Yard signs which do not comply with this section of the ordinance or any other requirement of this Chapter may be immediately removed by the Staff without notification to the sign owner or the property owner upon which the sign is placed and will subject the sign owner and the property owner to the Fine Schedule as provided for in Chapter 13 of this Ordinance. Removed signs shall be held at the Area Plan Office for seven (7) days before being destroyed if not collected by the sign owner or representative.

10.9.6 Disposable signs (off-premise only)

- A. A sign permit is required for all off-premise disposable signs (a group of signs may be authorized under a single permit if they are identical in size and face). Fee will be based on volume.
- B. Disposable signs shall not exceed four (4) square feet in sign area and three (3) feet in sign height and shall not be placed closer than fifty (50) feet to any other off-premise disposable sign on the same parcel.
- C. All disposable signs must display the permit number, the date the permit is issued, name of the business, the physical address of the business and a valid phone number for each sign attaching this information utilizing a permanent method of attachment. Characters are to be a minimum of one-half (1/2) inch in height and a minimum of one-sixteenth (1/16) inch in character width.
- D. Disposable signs may be displayed for a period not to exceed one hundred twenty (120) days unless expressly allowed in writing by the Executive Director.
- E. Disposable signs may not be utilized to identify a home occupation.
- F. Disposable signs shall be located in a reasonable and safe manner as determined by the Executive Director;
- G. Disposable signs must be maintained and kept in good repair and must meet the construction/design standards provided for in this section; and,
- H. Disposable signs which do not comply with this section of the ordinance or any other requirement of this Chapter may be immediately removed by the Staff without notification to the sign owner or the property owner upon which the sign is placed and will subject the sign owner and the property owner to the Fine Schedule as provided for in Chapter 13 of this Ordinance. Removed signs shall be held at the Area Plan Office for seven (7) days before being destroyed if not collected by the sign owner or representative.

10.9.7 Signs on farm property

- A. Farms shall be allowed to place one (1) permanent off-premise sign, regardless of parcel size, in addition to any billboard allowance, on its premises as long as such signage is in compliance with this Chapter.
- B. Each farm shall be allowed additional, permanent off-premise signs on each farm property as long as they are no closer than three hundred (300) feet from any other off-premise sign on the same parcel. This distance is to be measured radially from the center of the sign.
- C. Size and setbacks will be applied by sign type as provided elsewhere in this Chapter.

10.9.8 Other Off-Premise Signs

Off-premise wall, ground and pole signs are allowed in commercial and industrial districts, excluding I-3 districts, as long as they meet the limitations, regulations and restrictions of Table 10.2 and any other standards or regulations of this Chapter. Any quantity limitations delineated in Table 10.2 are applicable to off-premise and on-premise signs in total.

10.10 LEGAL NONCONFORMING SIGNS

Permanent signs which were lawful prior to the time this Chapter was passed or amended, but which would be prohibited, regulated, or restricted under the terms of this Chapter shall be deemed legal nonconforming signs. Any such sign shall be allowed to continue (be grandfathered) until such time a major change is made to the sign, at which time a sign permit is required and the sign must be brought into compliance with this Ordinance unless, in the sole opinion of the Executive Director, the change qualifies under Subsection 10.10.1. Major changes include changing the size, adding lights, reconstruction and/or relocation. For the purposes of administering and enforcing this Ordinance, signs of historic significance, as determined by the Executive Director, shall not be subject to the regulations of this Section.

Non-permanent signs shall not be granted grandfather status and shall be subject to current Ordinance requirements as amended from time to time.

10.10.1 Exception

A permanent sign undergoing a major change may be allowed to continue, if in the sole opinion of the Executive Director, the change results in a reasonable and appropriate reduction in nonconformance and the allowance would not be detrimental to the health, safety, welfare and common good of the community.

10.10.2 Maintenance and repair

Nothing herein shall prevent maintenance, repainting or normal repair of legally established nonconforming signs.

10.10.3 Improvements

Legally nonconforming signs may not be enlarged, extended, moved, modified, reconstructed or structurally altered except in accordance with this Chapter.

10.10.4 Destroyed or damaged

A legally nonconforming sign which is destroyed or damaged to an extent exceeding fifty (50) percent of its sign area, may not be altered, replaced, or reinstalled unless it is in conformance with this Chapter or qualifies for an exception under subsection 10.10.1 of this Chapter. If the damage or destruction is fifty (50) percent or less of the sign area, the sign may be restored to its original condition within a time frame established by the Executive Director.

10.11 PROHIBITED SIGNS

10.11.1 Search lights

Search lights shall be prohibited.

10.11.2 Tower & WECS signs

No sign shall be placed on any communication, radio or cell tower without the approval of the owner and the Staff. Signs on any Wind Energy Conversion System (WECS) shall not be permitted except those in compliance to the standards of Chapter 7 of this Ordinance.

10.11.3 Signs similar to emergency or traffic functions

Signs which, by reason of their size, location, movement, content, coloring or manner of illumination, may be confused with or constructed as a traffic control sign, signal or device, or the light of an emergency or road equipment vehicle, or which hide from view any traffic or roadway sign, signal or device are prohibited.

10.11.4 Signs which obstruct

Signs which obstruct any door, fire escape, stairway, sidewalk or any opening intended to provide air, egress or ingress for any building or structure shall be prohibited unless expressly allowed elsewhere in this Ordinance.

10.11.5 Other signs

Signs which are not included under the types of signs allowed in this Chapter are prohibited unless, in the sole discretion of the Executive Director, the prohibited sign is comparable to an allowed sign type and where such sign meets all standards and regulations of this Ordinance applicable to such sign type. Any decision of the Executive Director may be appealed to the Area Board of Zoning Appeals under the appeal provisions located in Chapter 12, Section 12.6 and upon payment of any appeal fees listed in the Area Plan Official Fee Schedule.

10.12 EXEMPT SIGNS

The following signs shall be exempt from the permit requirements of this Chapter unless specifically required below and as long as they comply with the restrictions and limitations contained in this Section and with any other applicable standards, restrictions, rules or regulations of this Chapter. No exempt sign may impede upon an ADA access route or, in the sole opinion of the Executive Director, create an

unreasonable circulation obstacle to those covered by ADA law, create a visual impairment or create a public nuisance.

Address identification regulations and standards can be found in Chapter 12, Section 12.16.

All exempt signs are restricted by the Visual Clearance Triangle regulations found in Chapter 3, Section 3.0.7 unless specifically exempted elsewhere in this Section.

INDEX:

<u>Sign Type</u>	<u>Section #</u>
A-frame and T-frame signs.....	10.12.15
Agricultural Land Signs.....	10.12.2
Barn Quilt Signs.....	10.12.21
Bench signs.....	10.12.18
Changeable Copy Signs, Portable.....	10.12.19
Community service central displays/Community Adoption Signs.....	10.12.17
Cylindrical Poles.....	10.12.1
Decorative Signs(Banners, lights, balloons, pennants and streamers).....	10.12.16
Disposable signs – on premise.....	10.12.12
Drive-through boards.....	10.12.3
Feather Flag Banners.....	10.12.4
Flags.....	10.12.5
Government signs.....	10.12.7
Historical location signs.....	10.12.6
Incidental Parking Lot Signs.....	10.12.9
Incidental Signage, Other.....	10.12.10
Integral Signs.....	10.12.8
Murals, Wall Graphics And Works Of Art.....	10.12.26
Natural Composit Signs.....	10.12.24
Neighborhood watch and similar community awareness signs.....	10.12.20
Park or athletic field fence signage, wall signage and scoreboard signage...	10.12.29
Public Signs.....	10.12.27
Retail Signage.....	10.12.23
Suspended signs.....	10.12.13
Utility Marker Signs.....	10.12.28
Vehicle Signs.....	10.12.25
Water Tower Signs.....	10.12.22
Window signs and signs viewable through a window.....	10.12.14
Yard Signs – on premise.....	10.12.11

10.12.1 Cylindrical Poles

Rotating or stationary cylindrical poles are exempt providing they meet the following standards:

- A. No cylindrical pole shall exceed fifty (50) inches in length;
- B. No cylindrical pole shall exceed six (6) inches in diameter;
- C. All cylindrical poles shall be attached by brackets to a building wall of the business for which the sign is representing;

- D. The top of the pole shall not extend above the roof line of the building to which it is attached;
- E. Such signs may move or rotate; and,
- F. May be illuminated as long as the illumination is, in the sole opinion of the Executive Director, adequately subdued to prevent a nuisance to neighboring properties.

10.12.2 Agricultural signs

Signs located on agricultural land (land used for Agricultural purposes) are exempt provided they are less than two (2) square feet in area and each sign maintains fifty (50) feet of separation between agricultural land signs. All other signs allowed on agricultural land must comply with the Standards and Regulations of Chapter 10 of this Ordinance.

10.12.3 Drive-through boards

Each drive-through establishment shall be allowed one (1) free-standing or wall mounted board per drive-through lane which shall not exceed forty-eight(48) square feet in area or eight (8) feet in height and shall be located adjacent to and oriented toward the drive-through lane. In addition, each drive through lane shall be allowed a separate speaker post in the drive-through area.

10.12.4 Feather Flag Banners

Feather Flag Banners (FFB) may be utilized in any zoning district designated as Commercial or Industrial as long as no two FFB's are located within any fifty (50) foot radius. The banners may be placed up to the right-of-way line or property line as long as the edge of the flag, when fully extended, does not cross any right-of-way or property line or into a Visual Clearance Triangle as defined in Section 3.0.7.

10.12.5 Flags

Flags that are not country, state or a unit of local government shall not exceed sixty (60) square feet. Flagpoles accompanying all flags shall meet all setback requirements and shall be limited to a height of thirty (30) feet in residential districts and forty (40) feet in non-residential districts. Government entities are expressly excluded from the limitations of this Section.

10.12.6 Historical location signs

Signs for property designated by the Federal, State or Local government as a historic location, site or landmark and which meet the definition of a Historical Sign as provided for in Chapter 14 of this Ordinance. Such signs are limited to the size restrictions and developmental standards for each sign type as specified in this Chapter and must remain outside a visual clearance triangle unless otherwise authorized in writing by the Executive Director.

10.12.7 Government signs

Signs utilized to fulfill essential functions of a governmental entity or department to promote safety, health and the general welfare of the community shall be allowed without regard to Appendix B: Bulk Use developmental standards or other

regulations contained within this Chapter due to the essential nature of their content. Signs placed by a government entity or department indicating a direction to a place, entity or activity or which identifies or memorializes a location or structure and which do not exceed four square feet in sign area are exempt from all regulations of this Chapter; otherwise, must be in compliance with the standards and regulations for the sign type utilized.

10.12.8 Integral signs

Signs carved into stone, concrete or similar material or made of bronze, aluminum, or other permanent type construction and made an integral part of a building

10.12.9 Incidental parking lot signs

Incidental parking lot signs are signs which are placed or displayed within a parking lot, near an ingress/egress route, along a driveway lane/maneuvering aisle or within a six (6) foot buffer area bordering the perimeter of a parking lot, driveway or facility loading/unloading area and which are intended to supply information to people using such lots including, but not limited to, liability, entering, exiting, entrance identifications and/or directional information to facilitate the safe movement of vehicles and pedestrians served by the parking area and the pedestrian circulation routes. Handicap parking and routing provision signs are also covered under this sub-section. Incidental parking lot signs shall not contain or display any advertising or commercial message other than an entities name or logo.

A. Location

These signs shall be installed in a manner which does not, in the sole opinion of the Executive Director, present a hazard to traffic entering or leaving the premises. No sign or part of a sign may extend into or over a right-of-way, ADA travel route, area utilized for parking or any other vehicle or pedestrian travel route.

B. Maximum Area

Incidental parking lot signs shall not exceed four (4) square feet in area.

C. Maximum Height

No incidental sign shall be exceed fifteen (15) feet in sign height.

D. Setbacks

Incidental parking lot signs shall be allowed without regard to setbacks but shall remain free of visual clearance triangle requirements and shall not be placed in a location which, in the sole opinion of the Executive Director, create a safety impairment.

E. Sign allowance

Incidental parking lot signs shall not count toward the total allowable signage for any parcel. Incidental parking lot signs may be internally illuminated but such lighting shall be subdued in a manner which does not create a light intensity nuisance.

F. Waiver

A property occupant may request, in writing, a waiver from the size and location limitations of this section which, at the sole discretion of the Executive Director, may be granted or denied. Any decision made by the Executive Director must be in writing. Any decision of the Executive Director may be appealed to the Area Board of Zoning Appeals.

10.12.10 Incidental Signage, Other

Each property used for commercial, industrial, institutional or government purposes is entitled to an accumulation of incidental signage up to sixty (60) square feet of sign face as long as no individual sign exceeds sixteen (16) square feet of sign area. All incidental signage covered under this subsection may be placed up to the property line or right-of-way line, whichever is most restrictive, as long as it does not infringe into the vision clearance triangle as provided for in Section 3.0.7 of this Ordinance or create what, in the sole opinion of the Executive Director, is a safety hazard or nuisance. Any decision of the Executive Director may be appealed to the Area Board of Zoning Appeals. In the case of a facility which includes refueling pumps or recharging stations, the signage included on or attached to the pumps or recharging stations is allowed in addition to the incidental signage provided for above or any other sign limitations provided in the Chapter.

10.12.11 Yard signs – on premise

- A. Shall not exceed six (6) square feet in sign area and five (5) feet in sign height;
- B. Must be separated by no less than twenty (20) feet; and,
- C. Shall be located in a reasonable and safe manner as determined by the Executive Director.

10.12.12 Disposable signs – on premise

- A. Shall not exceed four (4) square feet in sign area and three (3) feet in sign height;
- B. May not be located in a right-of-way;
- C. Shall not be located closer than twenty (20) feet to any other on-premise, disposable sign; and,
- D. Shall be located in a reasonable and safe manner as determined by the Executive Director.

10.12.13 Suspended Signs

Signs suspended above a walkway or road/street right-of-way shall be allowed, provided such signs meet the following criteria:

- A. No suspended sign face shall exceed twelve (12) square feet in sign area;
- B. No part of a suspended sign shall extend closer than eight (8) feet above the area over which it is suspended;
- C. Only one (1) suspended sign per building entrance shall be allowed; and,
- D. Suspended signs may extend above a right-of-way without requiring authorization from the respective legislative body.

10.12.14 Window signs and signs viewable through a window

All windows shall be allowed to contain signs or advertising information as long as the signs or information are mounted on the glass pane only; regardless of whether or not mounted from the inside or the outside of the window.

Any interior signage or promotional displays visible from the outside through a window are exempt.

All window signs or signs viewable from a window must meet the illumination standards of Section 10.4 of this Chapter.

10.12.15 A-frame and T-frame signs

A-frame or T-frame supported signs are allowed. A-frame or T-frame signs may be placed on a sidewalk provided that such placement is in a reasonable manner and, in the sole opinion of the Executive Director, does not create an unsafe condition for pedestrians or vehicular travel. Off premise A-frame and T-frame signs are not allowed unless authorized by variance from the Area Board of Zoning Appeals. For purposes of this Subsection, an A-frame or T-frame sign placed on a sidewalk in a right-of-way is not considered an off-premise sign if the section of right-of-way in which the sign is located abuts the sign owners property.

10.12.16 Decorative Signs (Banners, lights, balloons, pennants and streamers)

Decorative signs are allowed as long as they are kept in good repair and in a neat, clean and attractive condition and do not create a general nuisance for the public or a near-by property owner. Failure to maintain such signs or utilizing such signs in a way that creates a nuisance may be removed or caused to be removed at the discretion of the Executive Director and will be at the expense of the sign and/or property owner. Property owners and/or sign owners can be assessed a fine for failure to remove a sign upon written notification from the Staff. All such signs must be positioned in a manner which does not create a safety hazard, nuisance or motorist distraction nor shall they interfere with pedestrian or vehicular circulation. Decorative signs are limited to sixty (60) consecutive days at a time. Each parcel, lot or tract of land is limited to no more than two (2) Decorative signs at a time and limited to two (2) such usages in any twelve (12) month period unless authorized in writing by the Executive Director. Any Decorative sign utilized for sixty-one (61) days or more in any twelve month rolling period requires a sign permit. Decorative signs must not infringe on the the vision clearance triangle as provided for in Section 3.0.7 of this Ordinance, or create what is, in the sole opinion of the Executive Director, a safety hazard or nuisance. The standards and limitations of this subsection may be modified upon written authorization of the Executive Director or with variance approval from the Area Board of Zoning Appeals.

10.12.17 Community service central displays/Community Adoption Signs

Identification signs incorporated in central displays of community service shall be allowed provided each sign:

- 1) meets the developmental standards for the sign type used;
- 2) the signage is authorized in writing by the property owner;

- 3) complies with the visual clearance triangle regulations found in Section 3.0.7 of this Ordinance ; and,
- 4) is set back at least ten (10) feet from the road right-of-way or property line, whichever is most restrictive.

Such signs are limited to non-profit organizations only. Such signs shall contain no entity promotional attributes or create what is, in the sole opinion of the Executive Director, a safety hazard or nuisance.

Signs placed to note a person or entities responsibility for maintenance of a public right-of-way area, such as “adopt a highway”, or financial support for landscaping and/or cleanliness of a road area shall be allowed provided each sign is:

- 5) Authorized in writing by the property owner;
- 6) no closer than one (1) foot to any road travel surface and/or shoulder;
- 7) meets the developmental standards for the sign type used;
- 8) complies with the visual clearance triangle regulations found in Section 3.0.7 of this Ordinance;
- 9) contains no entity promotional attributes other than an entity or companies name and/or logo; or,
- 10) create what is, in the sole opinion of the Executive Director, a safety hazard or nuisance.

10.12.18 Bench signs

Bench signs are allowed provided they do not create a safety hazard, as determined by the Executive Director. There is no setback requirement for a bench sign but they may not violate the vision clearance triangle standards, nor impede an ADA routing requirement or allowance. Any bench sign intended for placement in a right-of-way, must have written approval from the regulating legislative body.

10.12.19 Changeable Copy Signs, Portable

Portable, changeable copy signs are exempt if utilized for sixty (60) days or less; otherwise, they require a sign permit. Portable changeable copy signs must meet the standards for ground signs but are not counted toward a properties ground sign count allowance. These signs may not utilize either exterior or interior lighting; nor may they be placed within a vision clearance triangle area or be placed in a manner which, at the sole discretion of the Executive Director, create a safety hazard or nuisance. This subsection does not apply to portable, Changeable Copy signs utilized by a department of a governmental body.

10.12.20 Neighborhood watch and similar community awareness signs

- A. Are allowed on utility poles or road sign structures, excluding stop signs, as long as permission from the respective agency has been acquired. . Such signs are otherwise allowable subject to the regulations as required by the sign type;

- B. Shall be located in a reasonable and safe manner as determined by the Executive Director; and,
- C. Shall not exceed two (2) square feet in sign area.

10.12.21 Barn Quilt Signs

Barn Quilt signs are visual replicas of quilt, quilt patterns or quilt sections which are painted on a substrate for the viewing pleasure of the general public with no intended or actual economic benefit for any enterprise, organization or entity. All Barn Quilt Signs shall meet the following standards:

- A. There may be multiple Barn Quilt (BQ) Signs per Barn or Barn Crib with a maximum of 200 square foot of signage face per Barn side;
- B. An individual BQ Signs shall not exceed a face size of 8' square;
- C. All BQ Signs shall be surface mounted to a barn subject to Wall Sign Standards;
- D. All BQ Signs shall display a quilt pattern only (no verbiage);
- E. All BQ Signs shall be painted on an aluminum or wood based substrate (or equivalent);
- F. A BQ Signs shall be repaired when paint chipping, surface fading or any other effect to the sign creates a significant discontinuity or negative impact to the image;
- G. All BQ Signs shall be positioned to be completely visible from the road rights-of-way; and,
- H. BQ Signs may be mounted to a structure other than a barn or barn crib with written permission for the Area Plan Executive Director.

10.12.22 Water Tower Signs

Signs placed on any surface of a water tower tank which identify a municipality, utility, location, industrial park or other information. Those which advertise the name, products, services or other aspects of an industrial or commercial enterprise are not exempt from the permit requirements of this Chapter and shall be subject to the standards of a wall sign.

10.12.23 Retail Signage

On-premise signs on a property used for retail purposes which satisfy the following standards are exempt:

- A. The sign face is less than two (2) square feet;
- B. The sign does not utilize electronic features of any kind, whether interior or exterior;
- C. The sign is not located within a rights-of-ways;
- D. The sign does not impair visibility or distract drivers of motor vehicles;and,
- E. The sign does not interfere or disrupt any pedestrian or motor vehicle circulation route.

10.12.24 Natural Composite Signs

Information placed on or incorporated into the face of a natural substrate, such as, but not limited to, a stone, rock, marble or wood, are limited to use only to identify a street address or family name. They may not be placed in a right-of-way or in any manner, which in the sole opinion of the Executive Director, shall create a safety or nuisance to the community.

10.12.25 Vehicle Signs

Signs on vehicles or trailers of any type, upon which someone has painted, inscribed, written or mounted a sign unless the vehicle or trailer is inoperable, unregistered or stationary for a period of ten (10) business days or more, then a sign permit must be obtained.

10.12.26 Murals, Wall Graphics And Works Of Art

Murals, Wall Graphics and Works of Art with no commercial message or intent and which contain no name of any entity except the community, creator or those historically related to the mural, wall graphic or work of art.

Murals, Wall Graphics and Works of Art must comply with the standards, restrictions and regulations for the particular sign type. In cases of Works of Art, they shall be subject to accessory structure developmental standards.

10.12.27 Public Signs

Public signs erected by or on the order of a public official in the performance of a public duty, such as signs to promote safety, no trespassing, no skate boarding or vehicle/pedestrian routing management or similar such sign.

10.12.28 Utility Marker Signs

Signs for the purpose of marking utility cables and/or lines for public or private utilities or to provide safety or hazard notice. These signs must be located in a manner which, in the sole opinion of the Executive Director, does not create a safety hazard.

10.12.29 Park or athletic field fence signage, wall signage and scoreboard signage, subject to the standards listed below:

- A. Fence signage must not extend more than three (3) inches beyond the fence perimeter;
- B. All fence signage must have written authorization from the property owner;
- C. Any illuminated or electronic messaging sign must meet all standards for such signage as provide for in this Ordinance.

10.13 TEMPORARY SIGNS

Temporary signs do not require a permit. Temporary signs may be allowed at any non-residential location within the County, in accordance with the provisions of this Chapter. For residential districts, all signs must comply with Section 10.7 of this chapter. Temporary signs may not be placed to infringe the provisions of a visual clearance triangle as provided for in Chapter 3, Subsection 3.0.7, nor be placed in a manner, which, at the sole discretion of the Executive Director, creates a safety hazard or nuisance. Temporary signs are not allowed in a road or street rights-of-

way and must meet the regulations, development standards and setbacks for the particular sign type used.

Temporary signs used in conjunction with a temporary use permit shall be allowed for the duration of time the temporary use permit is valid.

In addition, all temporary signs must satisfy the following:

- A. Be located in a reasonable and safe manner as determined by the Executive Director;
- B. Be displayed for a period not to exceed twelve (12) months or as provided elsewhere in this Section. The twelve (12) months may be extended by a period not to exceed six (6) months if the extension is approved in writing by the Executive Director or his/her appointee. The display time limitations apply to any thirty-six (36) consecutive month rolling period;
- C. Be no greater than eight (8) feet in sign height;
- D. Be located in such a way that they do not obstruct the flow or sight pattern of vehicular or pedestrian traffic traveling on any established road/street right-of-way;
- E. Be at least twenty (20) feet from any adjacent residential district;
- F. Shall not exceed thirty-two (32) square feet in sign area;
- G. Be free of blinking lights;
- H. In compliance with all electrical installation building codes;
- I. Be in compliance with all other applicable regulations of this Chapter.

CHAPTER 11

ADMINISTRATIVE BODIES AND OFFICIALS

11.0 SUMMARY OF AUTHORITY

The county and municipal bodies and officials listed in this Chapter, without limitation upon such authority as each may possess by law, have responsibility for implementing and administering this Ordinance in the manner described herein.

11.1 BODIES AND OFFICIALS

11.1.1 County Commissioners

The County Commissioners hereby reserves to itself the following powers and duties in connection with the implementation of this Ordinance for the unincorporated areas of White County:

- A. To initiate amendments to this Ordinance and to adopt, reject, or amend proposals to amend or partially repeal the text of the Ordinance.
- B. To adopt, reject, or amend proposals to amend the zoning map pursuant to the procedures and standards for amendments set forth in Chapter 12, Administration.
- C. To adopt, reject, or amend a Planned Unit Development pursuant to the procedures and standards for amendments set forth in Chapter 12, Administration.
- D. To take such other actions not delegated to other bodies, which may be desirable and necessary to implement the provisions of this Ordinance.

11.1.2 Municipal legislative bodies

The legislative body of each of the participating municipalities hereby reserves to itself the following powers and duties in connection with the implementation of this Ordinance for the area within its jurisdiction:

- A. To initiate amendments to this Ordinance and to adopt, reject, or amend proposals to amend or partially repeal the text of this Ordinance.
- B. To adopt, reject, or amend proposals to amend the zoning map pursuant to the procedures and standards for amendments set forth in Chapter 12, Administration.
- C. To adopt, reject, or amend a Planned Unit Development pursuant to the procedures and standards for amendments set forth in Chapter 12, Administration.
- D. To take such other actions not delegated to other bodies which may be desirable and necessary to implement the provisions of this Ordinance.

11.1.3 Area Plan Commission

A. Establishment

There is established the Area Plan Commission, to be known as the White County Area Plan Commission. The Area Plan Commission shall be a continuation of the present Area Plan Commission established under plan law, IC 36-7-4-200 Series: Commission Establishment and Membership, as amended from time to time.

B. Composition

The Area Plan Commission shall consist of membership as authorized by IC 36-7-4-211 as amended from time to time and shall be prescribed as follows:

1. Two (2) representatives from each city having a population of less than ten thousand (10,000)
 - a. One (1) member appointed by the municipality legislative body from its membership
 - b. One citizen member appointed by the municipal executive
2. One (1) representative from each town having a population of two thousand one hundred (2,100) or less that had a representative before January 1, 1979
3. Such representatives from towns having a population of not more than two thousand one hundred (2,100) as are provided for in IC 36-7-4-210 as amended from time to time
4. One (1) member appointed by the county executive from its membership or the county executive's designee
5. One (1) member appointed by the county fiscal body from its membership
6. One (1) representative appointed by the school corporation superintendents within the jurisdiction of the Area Plan Commission
7. One (1) of the following appointed by the County Executive:
 - a. The county agricultural extension educator
 - b. The county surveyor or the county surveyor's designee
8. One (1) citizen member appointed by the County Executive who is:
 - a. A resident of the unincorporated area of the county; or
 - b. A resident of the county who is also an owner of real property located in whole or in part in the unincorporated area of the county
9. One (1) citizen member appointed by the county fiscal body who is:
 - a. A resident of the unincorporated area of the county; or
 - b. A resident of the county who is also and owner of real property located in whole or in part in the unincorporated area of the county

C. Terms of office

1. Each citizen member shall be appointed for a four (4) year term expiring on the first Monday of January of the fourth year after the year of the member's appointment.

2. Advisory council members shall be elected for one (1) year terms, terminating at the end of the year.
3. Any member who is appointed from the membership of a legislative body or a park board is coextensive with the member's term of office on that body, board, or council, unless the body, board, or council appoints, at its first regular meeting in any year, another to serve as its representative.
4. All other members shall serve a four (4) year term expiring on the first Monday of January of the fourth year after the year of the member's appointment.

D. Conflict of interest

Pursuant to IC 36-7-4-223, no member of the Area Plan Commission or appropriate legislative body may participate in a hearing or decision of that Commission or body concerning a zoning matter in which he or she has a direct or indirect financial interest. The Commission or body shall enter in its records the fact that its member has a disqualification.

E. Territorial jurisdiction

The Area Plan Commission shall have jurisdiction over all the land subject to this Ordinance.

F. Duties

For the purpose of this Chapter, the Area Plan Commission shall have the following duties:

1. Initiate and review all proposed amendments to the text of this Ordinance and the Zoning Map pursuant to the procedures and standards set forth in Chapter 12, Administration.
2. Review and make Findings of Fact on subdivision plats, site development plans, planned unit developments, and other similar plans for proposed land developments within the Commission's jurisdiction.
3. Initiate, perform, administer and enforce the Comprehensive Plan, Zoning Ordinance, and Subdivision Control Ordinance.
4. To initiate amendments to the White County Subdivision Control Ordinance and to adopt, reject, or amend proposals to amend or partially repeal the text of this White County Subdivision Control Ordinance.
5. To approve, approve with modifications, or deny all applications for waivers from the Subdivision Control Ordinance pursuant to the procedures and standards for plat approval set forth in the Subdivision Control Ordinance.
6. To supervise and adopt rules for the administration of the affairs of the Area Plan Commission.
7. Record and file all bonds and contracts and assume responsibility for the custody and preservation of all papers and documents of the Area Plan Commission.

8. To prepare, publish, and distribute reports, ordinances, and other material related to the Area Plan Commission activities as authorized by this Ordinance or any other applicable law.
9. To invoke any legal, equitable, or special remedy available by law or this Ordinance for the enforcement of the provisions of this Ordinance or actions taken there under.
10. To exercise all powers conferred on it by law, local ordinance or rule in the manner so prescribed. This Section shall not be construed as a limitation on such powers.

G. Staff

The staff of the Area Plan Commission shall consist of the Executive Director, as defined in Chapter 14, Definitions, and any other persons employed or otherwise hired by the Area Plan Commission from time to time to assist the Executive Director or the Area Plan Commission.

H. Rules and procedures

The following rules and procedures shall apply:

1. The Area Plan Commission shall have sole authority to adopt any and all rules under IC 36-7-4-401 and any and all procedures concerning organization, selection of officers, forms for applications, filing requirements, other than as to place of filing as herein provided for, procedures, notices for and conduct of meetings and public hearings
2. Facilities and funding

The County shall provide suitable facilities and security for the holding of Area Plan Commission meetings and hearings and the storage of its records, documents, and accounts, and in its annual budget to provide sufficient funds for the functioning of the Commission and its staff

3. Prescribed filing forms

All applications for subdivision plats, site development plans, Zoning Ordinance amendments, improvement location permits, or other petitions coming before the Commission or its staff shall be filed in the form and quantities prescribed by the Commission.

11.1.4 Board of Zoning Appeals

A. Establishment

The Board of Zoning Appeals is hereby established under the planning law, being IC 36-7-4-900, as added by Acts 1981, Pub. L. 309 Sec. 23., and is to be known as the White County Board of Zoning Appeals and shall be a continuation of the present Board of Zoning Appeals.

B. Composition

The Board of Zoning Appeals shall consist of the following five (5) members.

1. One (1) citizen member appointed by the Area Plan Commission, from its membership.
2. One (1) citizen member appointed by the Mayor of Monticello provided said citizen member is not a member of any Plan Commission.
3. Two (2) citizen members, one who must be a member of the Plan Commission and one who is not a member of any Plan Commission, appointed by the County Commissioners.
4. One (1) citizen member, who may not be a member of any plan commission, appointed by the executive of the second largest municipality in the county participating in the commission.

C. Terms of office

Following adoption of this Ordinance, each member of the BZA shall be reappointed for the balance of the term being served on the present Board of Zoning Appeals. Thereafter, each member shall be for a term of four (4) years. Each term shall expire on the first Monday of January of the fourth year of the four-year (4-yr.) term. Following the term expiration, a member shall be considered a temporary appointee until such time as a replacement is named or the member is reappointed. All votes taken during the interim appointment shall reflect the status of the temporary appointee.

1. The member selected by the Area Plan Commission shall hold office for a term of four (4) years.
2. The member appointed by the Monon Town Council shall serve for a term of three (3) years.
3. One member appointed by the County Commissioners shall hold office for a term of three (3) years and the other shall hold office for a term of two (2) years.
4. The member appointed by the Mayor of Monticello shall serve for a period of two (2) years.

D. Conflict of interest

Pursuant to IC 36-7-4-909, a member of the Board of Zoning Appeals may not participate in a hearing or decision of that Board concerning a zoning matter in which he or she has a direct or indirect financial interest. The Board shall enter in its records the fact that its member has such a disqualification.

E. Jurisdiction

1. Territorial jurisdiction

The Board of Zoning Appeals shall have jurisdiction over all the land subject to the Zoning Ordinance.

2. Subject matter jurisdiction

The Board of Zoning Appeals shall have exclusive subject matter jurisdiction for the following

- a. Development standards variance

- b. Special exception uses
- c. Administrative appeals

F. Staff

The staff of the Board of Zoning Appeals shall consist of the Executive Director as defined in this Ordinance, and other persons employed or otherwise hired by the Board of Zoning Appeals to assist the Executive Director.

G. Rules and Procedures

1. Rules and procedures

The Board of Zoning Appeals shall have sole authority to adopt any and all rules under IC 36-7-4-916 and any and all procedures concerning organization, selection of officers, forms for applications, filing requirements, other than as to place of filing as herein provided for, procedures, notices for and conduct of meetings and public hearings.

2. Facilities and funding

The County shall provide suitable facilities for the holding and security of Board of Zoning Appeals meetings and hearings and the storage of its records, documents, and accounts, and in its annual budget to provide sufficient funds for the functioning of the Board and its staff

3. Filing

All applications for variances, special exception uses, and requests for appeal shall be filed by the applicant with the staff of the Board of Zoning Appeals and in the form prescribed by the Board.

H. Prescribed filing forms

All applications for special exception uses, variances, or appeals or other petitions coming before the Board of Zoning Appeals or its staff shall be filed in the form and quantities prescribed by the Board.

11.1.5 Technical Review Committee

The Area Plan Commission shall establish a Technical Review Committee for the purpose of providing detailed reviews and recommendations to the Area Plan Commission concerning proposed development plans or subdivision plats as prescribed in the White County Indiana Zoning Control Ordinance or as prescribed in the White County Indiana Subdivision Control Ordinance as amended from time to time.

A. Composition

Membership of the Technical Review Committee will consist of five (5) members and assigned as follows:

- 1) The Area Plan Executive Director or his/her designee; appointing authority, Area Plan Executive Director;
- 2) The County Surveyor or his/her designee; appointing authority, County Surveyor;

- 3) Three members of the Area Plan Commission, other than the Surveyor; appointing authority, Area Plan Commission.

Ex Officio members of the Technical Review Committee consist of the following:

- 1) County Health Department; Health Department
- 2) County Surveyor;
- 3) A representative and/or designee of the County Soil and Water Conservation District;
- 4) County Highway Engineer and/or Superintendent from the appropriate jurisdiction;
- 5) Wastewater Superintendent from the appropriate jurisdiction;
- 6) Water Superintendent from the appropriate jurisdiction;
- 7) A Fire District Representative from the appropriate jurisdiction;
- 8) Building Department;
- 9) Clerk-Treasurer of the body with jurisdictional authority over the geographic area in which the development is proposed; in the case of an area in the unincorporated area of the County, the County Executive; and
- 10) Any other persons deemed appropriate by the Executive Director.

B. Duties

The Technical Review Committee shall limit its attention and recommendations to the design and construction aspects of the proposed development or subdivision with emphasis placed on public improvements, utilities, drainage, landscaping, parking, and other development standards. Projects shall be reviewed for compliance with the Zoning Ordinance and compatibility with the Comprehensive Plan, including, when applicable, the aspects of design within an adopted Historic Preservation District.

1. The purpose of the Technical Review Committee is to provide written recommendations pertaining to technical aspects of the design and construction plans; approval or disapproval of a development or subdivision is clearly the responsibility of the Area Plan Commission
2. The Technical Review Committee shall have the authority to request that a docket be continued by the Area Plan Commission until the Committee has reviewed revised plans submitted by the petitioner(s).

C. Coordination between zoning and subdivision ordinances

The Committee is established under both the Zoning Ordinance and the Subdivision Control Ordinance to serve the differing needs of these two (2) ordinances. The Committee shall be made up of the same members under both ordinances in order to facilitate coordination of the decision-making by the Area Plan Commission with respect to the design and construction aspects of these two (2) ordinances.

D. Committee meetings

Because the Technical Review Committee is strictly a committee and does not have the authority to take any official action, the Committee shall not be bound to holding

public meetings. The Committee shall meet as necessary. After each meeting, the Committee shall then submit its review comments and recommendations in writing to the Area Plan Commission.

Notification of Tech Committee meetings shall go to all Tech Committee members and to all Ex Officio members determined by the Executive Director to be pertinent to the submitted application.

11.1.6 Hearing Examiner

The Area Plan Commission may delegate to a Hearing Examiner the authority to conduct any public hearing required to be held by the Commission or make any decision required to be made by the Commission, or both, excluding any authority or decisions provided for in the Subdivision Control Ordinance or the 700 Series, Subdivision Control of State Statute IC 36-7-4.

Such hearings must be held upon the same notice and under the same rules as a hearing before the entire Commission, including providing a Written Findings of Fact and Decision, as is required by law for the Commission.

A decision made under the authority of this subsection may not be a basis for judicial review, but may be appealed to the Area Plan Commission. Any interested party who wishes to appeal a decision made by the Hearing Examiner, must file the appeal not later than five (5) days after the date of the decision. The Area Plan Commission will then hold the prescribed hearing and render its decision.

11.1.7 Hearing Officer

The Area Plan Commission, by its Rules and Procedures, or if provided for by Ordinance, may authorize a Hearing Officer to conduct hearings to disposition certain matters under an Alternate Procedure established in Chapter 12, Section 12.15 of this Ordinance.

11.1.8 Plat Committee

The Area Plan Commission shall establish a Plat Review Committee for the purpose of reviewing and approving/denying subdivision plats and replats when prescribed for in the White County Indiana Subdivision Control Ordinance.

A. Composition

The Plat Committee shall consist of five (5) members appointed by the Area Plan Commission. Membership of the Plat Committee must include at least one member from the Area Plan Commission; (reference IC 36-7-4-701 (e)). Representatives of the Tech Review Committee may attend as Ex Officio members of the Plat Committee.

B. Term

Each member of the Plat Committee will have a term of one (1) year which will begin January 1 and end December 31 of each respective year. The terms shall automatically renew for consecutive one (1) year terms until such time as:

- 1) The member resigns; or,
- 2) The member is terminated by the Area Plan Commission.

C. Duties

Review and approval/denial of subdivision plats and replats when prescribed for in the White County Indiana Subdivision Control Ordinance

D. Powers/Authority

Plat Committee shall have all the powers of the Plan Commission as they pertain to subdivision plats

E. Committee meetings

The Plat Committee shall each year, prior to the first day of December, establish a meeting calendar for the following year. The Committee calendar shall consist of at least eight (8) scheduled meetings for each calendar year. Due to the nature of the hearings slated for Plat Committee review, the Plat Committee meetings are not required to be heard in a public venue nor are they required to give public notice of their meetings. However, within ten (10) days after the Plat Committee gives primary approval of a subdivision plat, the Staff shall provide written notice to interested parties of their right to appeal a decision of the Plat Committee to the Area Plan Commission. (Reference IC 36-7-4-701 (d))

Any party wishing to file an appeal of a Plat Committee decision must file the appeal with the Staff not more than five (5) days after a copy of the Plat Committees action is mailed to the interested party

F. Official action

The Plat Committee may take action only by a majority (quorum) vote. (Reference IC 36-7-4-701 (e))

CHAPTER 12 ADMINISTRATION

12.0 APPLICATION AND PERMIT TYPES

12.0.1 Petition applications required

An application shall be submitted for each of the following types of petitions:

- A. Development Standard Variance
- B. Special Exception Use
- C. Appeal of an Administrative Decision
- D. Zoning Map Amendment (Rezoning)
- E. Interpretations of the White County Zoning Ordinance
- F. An Improvement Location Permit in accordance with this Chapter, including sign permits (see also Chapter 10, Sign Standards, for additional application and permit provisions).
- G. Planned Unit Development, as prescribed by Chapter 5, Planned Unit Development

12.0.2 Applications, general

A. Location

All applications shall be made on forms provided by the Office of the Area Plan Commission. All applicants shall submit original application form(s), completed in its/their entirety. All applications shall be accompanied with their associated fee(s), and all other required documents as prescribed by this Ordinance.

B. Determination of a Complete Application

No application shall be considered complete until (a) the petitioner has provided a completed application form, (b) the application form is filed in the number of duplicate copies as directed by the Executive Director, (c) the form contains all owner and applicant signatures, and (d) the required fee or fees have been paid.

C. Drawing form, scale and size

All drawings shall be at a scale not smaller than one inch equals fifty feet (1" = 50") with a scale of one inch equals thirty feet (1" = 30') being preferred. Any other scale must be approved by the Executive Director. No individual sheet or drawing shall exceed twenty-four inches by thirty-six inches (24" x 36"). In addition, one (1) set of reduced copies sized at eleven inches by seventeen inches (11" x 17") shall be submitted. All sets of drawings submitted must be folded and collated.

D. Filing Deadlines and Meeting Schedule

1. Applications requiring a public hearing or meeting

An application requiring a public hearing or meeting will not be scheduled for such hearing or meeting unless filed in proper form and number and containing all required information. All public hearings and meetings to consider applications filed pursuant to the White County Zoning Ordinance shall be scheduled at the same time as the regular meetings of such body, unless otherwise provided by order of the appropriate body. A public hearing for an application so filed will be scheduled pursuant to the Calendar of Meetings and Filings Dates published by the relevant body each year.

2. Applications not requiring a public hearing

An application that does not require a public hearing shall be filed in proper form and number and contain all required information. An application so filed will be processed on a first-filed, first processed basis.

3. Supplemental data for previously filed applications

Whenever supplemental data in connection with a previously filed application is required by the County, appropriate legislative body or offered by the applicant, it shall be submitted no later than the revised submittal deadline published in the Calendar of Meeting and Filing Deadlines and shall be considered at a hearing or a meeting or acted upon in connection with such application. The filing of such data may, at the discretion of the Executive Director and/or the body entertaining the application, be cause to delay a requested or scheduled hearing or decision date.

E. Additional information required

Every applicant shall submit such other data, information, or documentation as the Executive Director, the Area Plan Commission, the Area Board of Zoning Appeals or any appropriate legislative body before which its application is pending may deem necessary or appropriate to achieve a full and proper consideration and disposition of the particular application. The Area Plan Commission further reserves the right to require an impact statement explaining the impacts of a project on the County. This includes the use of an interpreter when necessary.

12.1 OFFICIAL FEE SCHEDULE

A separate ordinance, as amended from time to time, shall establish a schedule of fees, charges, and expenses and a collection procedure for zoning permits, sign permits, certificates of zoning compliance, special exception use permits, development standards variances, appeals, applications to amend this ordinance, rezonings, and other matters pertaining to this Ordinance or the operation of the Area Plan Department.

12.1.1 Maintenance

The Area Plan Staff shall maintain the Official Fee Schedule, charges, and expenses, as set forth periodically by the County Commissioners, and also a collection procedure for permits, appeals, and other petitions pertaining to the White County Zoning Ordinance and the White County Subdivision Control Ordinance.

12.1.2 Availability

The Official Fee Schedule shall be available to the public in the office of the Area Plan Commission and may be altered or amended only by ordinance of the County Commissioners.

12.1.3 Responsibility of payment

The owner of the property which is the subject of an application shall be liable for the payment of the fee. In the event that the applicant is different than the owner, the owner and the applicant shall be jointly and severally liable for the payment of the fee.

12.1.4 Payment in full

All applicable fees, charges, and expenses shall be paid in full by the applicant or owner, at the time of application. Failure to fully pay any such fee or required deposit at application shall be grounds for refusing to process an application and for denying or revoking any permit or approval sought or issued with respect to the land or development to which the unpaid fee or required deposit relates. Only the Area Plan Commission, Area Board of Zoning Appeals, and/or the County Commissioners have the ability to waive fees prescribed by the Official Fee Schedule.

12.1.5 Contracting of independent professionals

Payment to defray the costs of contracting with independent professionals to provide services required for consideration of an Area Plan Department matter shall be set by the County Commissioners. Such professional costs may include, but are not limited to: planning, engineering, legal, traffic analyses, environmental impact or other similar studies; development plan review; or inspections.

12.2 PUBLIC HEARINGS AND MEETINGS

12.2.1 Setting a hearing or meeting

When the provisions of this Ordinance require a public hearing or public meeting in connection with any application filed pursuant to this Ordinance, it shall be heard in accordance with the published schedule of the official or body charged with conducting the hearing or meeting.

A. Time of meeting

The exact time for hearings or meetings held before the Board of Zoning Appeals or Area Plan Commission, as the case may be, shall be determined by the official filing deadline adopted annually. Applications shall be filed in the Office of the Area Plan Commission no later than the deadline published in the Calendar of Filing and Meeting Dates.

B. Notice to adjoining property owners

For all public hearings, the notice shall be provided to the public consistent with the requirements of this Chapter and the requirements of IC 5-3-1 as amended. A public notice required by this Ordinance shall meet the following requirements:

1. Preparation

The Staff shall prepare and provide a legal notice consistent with the requirements of IC 5-3-1 and the applicable Area Plan Commission, Board of Zoning Appeals, and/or appropriate legislative body's Rules of Procedure.

2. Content of public notice

In addition to stating the name of the applicant, the notice shall state the physical address of the subject property. In the event that the subject property does not have a physical address, a general description shall be given. The content of the notice shall also state the date, time and location of the hearing and the name of the presiding Board (White County Area Plan Commission/Area Board of Zoning Appeals/Hearing Officer/Hearing Examiner). The notice shall also include a legal description of the subject property.

3. Distribution

Staff of the Area Plan Commission Office shall distribute, by first class mail, written notice of the application to all interested parties in accordance with IC 5-3-1 as amended.

4. Certificate of issuance

Prior to the public hearing a certificate of issuance shall be prepared by the Staff of the Area Plan Commission Office and include such certification in the file of record to which it applies.

C. Newspaper notice

The Staff shall arrange for the publication of a public notice to be placed in a newspaper of general circulation in the jurisdictional area. Said notice shall include the same information as described in the notice to adjoining property owners subsection 12.21(B), Notice to adjoining property owners. The notice shall run at least one (1) time in the paper at least ten (10) days before the date of the meeting or hearing, in accordance with IC 5-3-1 as amended.

12.2.2 Review of Application Materials

All materials related to any application for which the White County Zoning Ordinance requires a hearing shall first be reviewed by the Staff to determine if the application is complete. The Staff shall also refer the application to other County bodies or officials for their comments as necessary. Each body and official to which an application is referred shall review such application and submit its comments thereon to the Staff for transmittal to the specific body or Official hearing the application.

12.2.3 Conduct of hearings

All other matters pertaining to the conduct of hearings shall be governed by the provisions of the White County Zoning Ordinance pertaining to, and the rules promulgated by, the official or body conducting the hearing.

12.2.4 Examination and copying of application and other documents

At any time following the giving of notice as required per IC 5-3-1-2 et seq. in this Chapter and upon reasonable request, any person may examine the application and, subject to the exceptions set forth in the Indiana Freedom of Information Act, all other

documents on file pertaining to the application. In addition, any person shall be entitled to copies of such application and documents upon reasonable request and payment of a fee prescribed by the Staff to cover the cost of such copies.

12.3 SUCCESSIVE APPLICATIONS (PETITIONS), APPEALS

12.3.1 Second applications barred without new grounds

Whenever any application (petition) or appeal filed pursuant to the White County Zoning Ordinance has been denied, a second application seeking essentially the same relief, whether or not in the same form or on the same theory shall not be brought before the County for one (1) year unless in a majority vote of the board or commission before which it is brought determines to reconsider the vote because there is substantially new evidence available, or a mistake of law or fact significantly affected the prior denial.

12.3.2 New grounds to be stated

A second application submitted on new grounds may be brought before the County in the same manner as a new application for the type of request made. Any such second application shall include a detailed statement of the grounds justifying a second consideration of such application, and place in the record all evidence available concerning changes of conditions or new facts that have developed since the denial of the first application.

12.3.3 Summary denial with or without hearing

Any such second application may be denied by the Executive Director summarily, and without hearing, on a finding that no grounds appear that warrants a new hearing. In any case where such application is set for a hearing, the applicant shall be required to establish grounds warranting reconsideration of the merits of the application prior to being allowed to offer any evidence. Unless such grounds are established, the application may be summarily dismissed for such failure.

12.3.4 Exception

Whether or not new grounds are stated, any such second application filed more than one (1) year after the denial of a prior application shall be heard on the merits as though no prior application had been filed. The applicant shall, however, be required to place in the record all evidence available concerning changes of conditions or new facts that have developed since the denial of the first application. In the absence of such evidence, it shall be presumed that no new facts exist to support the new petition that did not exist at the time of the denial of the first application.

12.4 DEVELOPMENT STANDARDS VARIANCE

A Development Standards Variance is designed to adjust the regulations (such as bulk, height, area, etc) of the White County Zoning Ordinance to the land for which the variance is granted. The primary basis for granting a development standard variance is the showing by the applicant that a practical difficulty exists if the letter of the law is strictly applied. In no case shall any variance to the terms of the White County Zoning Ordinance be authorized without the approval of the Area Board of Zoning Appeals (BZA) or the Area Plan Hearing Officer. All applications for a Development Standards

Variance will be heard utilizing the following procedures or, where applicable, the Alternate Procedure outlined in Section 12.16.

12.4.1 Authority

The Area Board of Zoning Appeals may upon petition authorize the granting of a variance from the development standards (such as height, bulk, or area) of the White County Zoning Ordinance, pursuant to IC 35-7-4-918.5 as amended. Additionally, the Area Board of Zoning Appeals may authorize the granting of a variance for a parcel in a recorded subdivision but only in those cases where the County Zoning Ordinance developmental standards are applied.

12.4.2 Burden of proof

The burden of demonstrating a need for the development standard variance falls upon the applicant seeking the variance. The burden of demonstrating that the terms of a development standard variance granted by the Area Board of Zoning Appeals have been met rests on the applicant granted the variance.

12.4.3 Application

The applicant shall submit a completed development standard variance application, the required filing fee, and required supporting information to the Executive Director. Supporting information shall include, but shall not be limited to, the following:

A. Dimensional Survey

The applicant shall obtain a dimensional survey of the subject property, prepared by a registered land surveyor, showing the property lines, distances from the property lines to the improvements and any structures on adjacent properties within 50' of the subject property's property lines, easements, existing and proposed structures complete with dimensions, parking, wells, grinders, and septic systems. Any costs associated in the completion of said survey shall be the responsibility of the applicant. The survey requirement may be waived or modified by the Executive Director in cases where he/she determines a scaled down survey or site plan will suffice.

B. Site Plan

A site plan as prescribed by this Chapter.

C. Written Commitments (if applicable)

Documentation of any written commitments as prescribed by this Chapter

12.4.4 Notification

Notification of public hearing as prescribed by this Chapter.

12.4.5 Action by Executive Director

Upon receipt of a properly completed application for variance, the Executive Director shall transmit the application to the Area Board of Zoning Appeals together with all the other administrative reports and recommendations regarding the proposed application.

The application shall be scheduled for a public hearing in accordance with the requirements of this Chapter.

12.4.6 Public hearing

The Area Board of Zoning Appeals shall, in a public hearing scheduled consistent with the adopted Calendar of Meetings and Filings Dates, review the variance application and required supporting information. The presentation of reports and testimony and all other aspects of the public hearing shall be consistent with the By-Laws of the Board.

12.4.7 Decision criteria prescribed by state law

In taking action on all development standard variance requests, the Area Board of Zoning Appeals shall use the following decision criteria, which are consistent with the requirements of Indiana Code.

A. General welfare

The approval will not be injurious to the public health, safety, morals, and general welfare of the community.

B. Adjacent property

The use and value of the area adjacent to the property included in the development standard variance request will not be affected in a substantially adverse manner.

C. Practical difficulty

The strict application of the terms of the White County Zoning Ordinance would result in practical difficulties in the use of the property.

12.4.8 Additional decision criteria

Additional decision criteria to be considered include the following:

A. Preservation and enjoyment of property

The granting of a variance is necessary for the preservation and enjoyment of a common property right possessed by other property owners in the same vicinity and district.

B. Minimum departure from the development standard

The granting of a variance would be a minimal departure from the strict application of the provisions of the White County Zoning Ordinance. In other words, the variance will be the minimum necessary to permit a reasonable use of the land and building.

C. Preserving the character of the area

The variance being sought does not essentially alter the character of the surrounding area.

1. Self-imposed causation

The variance request is not the result of an act or action, or lack thereof, of the applicant, property owner, contractor or any other party affiliated with the property to which the variance is being sought.

2. Economic gain

The need for the developmental standard variance is not based on a perceived reduction of, or restriction on, economic gain.

12.4.8 Possible action by Area Board of Zoning Appeals

Either at the public hearing or within thirty (30) days after the conclusion thereof, the Area Board of Zoning Appeals shall approve, conditionally approve, disapprove, or continue the request.

A. Approval

The application shall be approved if the Area Board of Zoning Appeals makes Findings of Fact which are consistent with this Chapter and IC 36-7-4-918.5 as amended.

B. Approval with Conditions

The application shall be approved with conditions if the Area Board of Zoning Appeals determines that the required Findings of Fact may be met if the applicant enters into written commitments which are then applied to the development standard variance.

C. Denial

The application shall be denied if Findings of Fact are inconsistent with this Chapter and/or IC 36-7-4-918.5 as amended.

D. Continued

The application may be continued by the Area Board of Zoning Appeals based on a request by the Executive Director, the applicant, a remonstrator, an interested party, by an indecisive vote of the Board, or a determination by the Board that additional information is required prior to taking further action on the request.

12.4.9 Written Findings of Fact

The Area Board of Zoning Appeals shall make a determination in writing of its findings for each application. The Board's findings shall be based upon the decision criteria identified in sub-sections 12.4.7 and 12.4.8 and consistent with IC 36-7-4-918.5. Findings of Fact shall be documented in written form by the Staff, and then signed by the Executive Director and Secretary of the Board at or before the following regularly scheduled meeting. Same Findings shall be provided to the Board for approval as an attachment to the meeting minutes.

12.4.10 Conditions and/or commitments

The Area Board of Zoning Appeals may impose conditions and limitations concerning bulk, height, area, and other matters relating to the purposes and objectives of the White County Zoning Ordinance. Such conditions shall be expressly set forth in the order granting the development standard variance. In addition to prescribing conditions, the Area Board of Zoning Appeals may require the owner of the subject property to make written commitments concerning the use or development of the property in accordance with this Chapter. Violation of any such condition or commitment shall be a violation of the White County Zoning Ordinance and constitutes a civil zoning violation subject to the provisions of Chapter 13, Enforcement.

A. Conditions

In granting any variance, the Area Board of Zoning Appeals may prescribe appropriate and reasonable conditions and safeguards which shall be in conformity with all of the following requirements. Violation of any conditions and safeguards, when made a part of the terms under which the variance is granted, shall be deemed a violation of the White County Zoning Ordinance and grounds for revoking the variance and punishable under the White County Zoning Ordinance.

1. The condition or safeguard must be designed to protect natural resources, the health, safety, and welfare and the social and economic well being of those who will use the land or activity under consideration, residents and landowners immediately adjacent to the proposed land use or activity, and the community as a whole.
2. The condition or safeguard must be related to the valid exercise of the police power, and purposes, which are affected, by the proposed use or activity.
3. The condition or safeguard must be necessary to meet the intent and purposes of the White County Zoning Ordinance, be related to the standards established in the White County Zoning Ordinance for the land use or activity under consideration, and be necessary to insure compliance with those standards.

B. Commitments

The Area Board of Zoning Appeals may accept written commitments concerning the use or development of the property as specified under IC 36-7-4-1015 as amended.

C. Recording conditions and commitments

After review of any conditions or commitments by the Executive Director, or his or her designee, the conditions or commitments shall be recorded, by the applicant, in the White County Records office within ninety (90) days of approval. A copy of the recorded document shall be provided to the Executive Director for inclusion in the petition file prior to the issuance of any Improvement Location Permit.

D. Compliance with conditions and commitments

No Improvement Location Permit shall be issued for any permit application which does not comply with the recorded conditions and/or commitments.

12.4.11 Limitation

Once granted, a development standard variance shall run with the land, unless specifically stated otherwise in the conditions or commitments of the Board's final determination, or until such time as: (1) the property comes into compliance with the White County Ordinance as written, or (2) the variance is terminated, in a public hearing, by the Area Board of Zoning Appeals.

12.4.12 Termination

A development standard variance may be terminated by the Area Board of Zoning Appeals, upon filing of a complaint by an interested person or the Executive Director, and upon finding at public hearing, with notice to the property owner and any other interested parties pursuant to Area Board of Zoning Appeal rules, that the terms of this Chapter or conditions of approval or commitments, have not been complied with. A development standard variance may be terminated by the Area Board of Zoning Appeals under the following procedures.

A. Determination by the Executive Director

In the event that the Executive Director determines that possible grounds exist for the termination of a development standard variance, the Executive Director shall notify the property owner, via Certified Mail, a minimum of ten (10) days, before the public hearing.

B. Public hearing

The Area Board of Zoning Appeals may, in a public hearing, determine if grounds for termination exist. The presentation of reports and testimony and all other aspects of the public hearing shall be consistent with the By-Laws of the Board.

C. Grounds for termination

At the public hearing the development standard variance shall be revoked if a finding is made by the Area Board of Zoning Appeals that one or more of the following is true:

1. Inconsistency with the White County Zoning Ordinance

The execution of the approval is not consistent with a requirement of the White County Zoning Ordinance.

2. Inconsistency with a condition of approval

The execution of the approval is not consistent with any condition of approval.

3. Inconsistency with a written commitment

The execution of the approval is not consistent with any written commitment.

4. Fraud or misrepresentation of facts

The approval was the result of fraud or the misrepresentation of facts.

12.4.13 Revocation of a variance

A development standard variance may be revoked by the Board of Zoning Appeals. A development standards variance shall be deemed automatically null and void if the

property, building, or structure for which the development standard variance was granted is for any reason demolished or destroyed. Thus, a new replacement building or structure shall be required to conform to regulations in effect at that time.

12.4.14 Appeals

Final decisions of the Area Board of Zoning Appeals under the 900 Series of IC 36-7-4 and section 1015 may be subject to judicial review as provided for in the 1600 Series of IC 36-7-4 as amended from time to time. A person must have standing to submit a petition for judicial review of a zoning decision of the Area Board of Zoning Appeals to the appropriate court. The petition shall be presented to the court not later than thirty (30) days after the date of the zoning decision that is the subject of the petition for judicial review. A person who fails to timely object to a zoning decision or timely petition for review a zoning decision within the thirty (30) day period prescribed in this section waives the right to judicial review under this subsection. For purposes of this subsection, the following is applied:

1. "Standing" is determined as provided for in IC 36-7-4-1603 of the 1600 Series as amended from time to time.
2. "Zoning Decision" is defined in IC 36-7-4-1016 of the 1000 Series as amended from time to time.

A person may file a petition for judicial review under this section only after exhausting all administrative remedies available within the Area Board of Zoning Appeals.

12.5 SPECIAL EXCEPTION USE PERMIT

Special Exception Use Permits are intended for those uses that, because of their unique characteristics and potentially adverse impact upon the immediate area, or the County as a whole, require a greater degree of scrutiny. In no case shall any special exception use be authorized without the approval of the Area Board of Zoning Appeals or the Area Plan Hearing Officer. All applications for a Special Exception Use Permit will be heard utilizing the following procedures or, where applicable, the Alternate Procedure outlined in Section 12.16.

12.5.1 Authority

The Area Board of Zoning Appeals may upon petition authorize the granting of a special exception use permit, pursuant to IC 35-7-4-918.2 as amended. A use must be listed as a special exception use in the Official Schedule of Uses, as amended from time to time, in order to be considered for a special exception use permit.

12.5.2 No presumption of approval

The listing of a special exception use within each zoning district shall not constitute an assurance or presumption that such special exception use will be approved. Rather, each proposed special exception use shall be evaluated on an individual basis, in relation to its compliance with the standards and conditions set forth herein and with the development standards for the district in which it is to be located.

12.5.3 Application

The applicant shall submit a special exception use permit application, the required filing fee, and required supporting information to the Executive Director. Supporting information shall include, but shall not be limited to, the following:

A. Dimensional Survey

An applicant shall obtain a dimensional survey of the subject property, prepared by a registered land surveyor, showing the property lines, distances from the property lines to the improvements, easements, existing and proposed structures complete with dimensions, parking, wells, grinders, and septic systems. The dimensional survey shall also include a general description of the land uses within fifty (50) feet of the subject property. Any costs associated in the completion of said survey shall be the responsibility of the applicant. The survey requirement may be waived or modified by the Executive Director.

B. Site plan

A site plan as prescribed by the Executive Director.

C. Written Commitments

Documentation of any written commitments as prescribed by this Chapter, if applicable.

12.5.4 Notification

Notification of public hearing as prescribed by this Chapter.

12.5.5 Action by the Executive Director

Upon receipt of a properly completed application for a special exception use permit, the Executive Director shall transmit to the Area Board of Zoning Appeals all administrative reports and recommendations regarding the proposed application. The application shall be scheduled for a public hearing in accordance with the requirements of this Chapter.

12.5.6 Public hearing

The Area Board of Zoning Appeals shall, in a public hearing scheduled consistent with the adopted Calendar of Filing and Meeting Dates, review the special exception use application and required supporting information. The presentation of reports and testimony and all other aspects of the public hearing shall be consistent with the By-Laws of the Board.

12.5.7 Decision criteria

In taking action on all special exception use permit requests, the Area Board of Zoning Appeals shall use the following decision criteria.

A. Consistency with the Official Schedule of Uses

The proposed special exception use is permitted in the proposed zoning district per the Official Schedule of Uses.

B. Consistency with all applicable development standards

The proposed development, if applicable, conforms to the development standards of the White County Zoning Ordinance.

C. Consistency with the intent of the White County Zoning Ordinance

Granting the special exception use will not be contrary to the general purposes served by the White County Zoning Ordinance, and will not significantly injure other property or uses in the same zoning district.

D. Consistency with the Comprehensive Plan

The proposed use will be consistent with the Comprehensive Plan and the character of the zoning district in which it is located.

12.5.8 Additional decision criteria

The Area Board of Zoning Appeals shall review the particular facts and circumstances of each proposed special exception use application in terms of the following standards and shall find adequate evidence that the proposed special exception use will:

- A. Be designed, constructed, operated, and maintained so as to be harmonious and appropriate in appearance with the existing or intended nature of the general vicinity and will not change the essential character of the same area;
- B. Not be hazardous or disturbing to existing neighboring uses;
- C. Be served adequately by essential public facilities and services such as highways, streets, police and fire protection, drainage structures, refuse disposal, water and sewer, and schools; or that the persons or agencies responsible for the establishment of the proposed use shall be able to provide adequately any such services;
- D. Not create excessive additional requirements at public expense for public facilities and services and will not be detrimental to the economic welfare of the community;
- E. Not involve uses, activities, processes, materials, equipment and conditions of operation that will be significantly detrimental to any persons of interest, property, or the general welfare by reason of excessive production of traffic, noise, smoke, fumes, glare, odors or other related factors;
- F. Have vehicular approaches to the property which shall be so designed as not to create an interference with traffic on surrounding public thoroughfares; and
- G. Not result in the destruction, loss, or damage of a natural, scenic, or historic feature of major importance.

12.5.9 Possible action by the Area Board of Zoning Appeals

At the public hearing, the Area Board of Zoning Appeals shall approve, conditionally approve, disapprove, or continue the request.

A. Approval

The application shall be approved if the Area Board of Zoning Appeals makes Findings of Fact which are consistent with this Chapter and IC 36-7-4-918.5 as amended.

B. Approval with conditions

The application shall be approved with conditions if the Area Board of Zoning Appeals determines that the required Findings of Fact may be met if the applicant enters into written commitments which are then applied to the special exception use permit

C. Denial

The application shall be denied if Findings of Fact are inconsistent with this Chapter and/or IC 36-7-4-918.5 as amended.

D. Continued

The application may be continued by the Area Board of Zoning Appeals based on a request by the Executive Director, the applicant, a remonstrator, an interested party, by an indecisive vote of the Board, or a determination by the Board that additional information is required prior to taking further action on the request.

12.5.10 Written Findings of Fact

The Area Board of Zoning Appeals shall make a determination in writing of its findings for each application. The Board's findings shall be based upon the decision criteria identified in sub-sections 12.5.7 and 12.5.8 above, and consistent with IC 36-7-4-918.2. Findings of fact shall be documented in written form by the staff, and then signed by the Executive Director and Secretary of the Board at or before the following regularly scheduled meeting. Same findings shall be provided to the Board for approval as an attachment to the meeting minutes.

12.5.11 Conditions and/or commitments

The Area Board of Zoning Appeals may impose conditions and limitations concerning use, construction, character, location, landscaping, screening, and other matters relating to the purposes and objectives of the White County Zoning Ordinance. Such conditions shall be expressly set forth in the order granting the special exception. In addition to prescribing conditions, the Area Board of Zoning Appeals may require the owner of the subject property to make written commitments concerning the use or development of the property in accordance with this Chapter. Violation of any such condition or commitment shall be a violation of the White County Zoning Ordinance and subject to the provisions of Chapter 13, Enforcement.

A. Conditions

In granting any special exception use, the Area Board of Zoning Appeals may impose appropriate and reasonable conditions. Violation of any condition, when made a part of the terms under which the special exception use permit is granted, shall be deemed a violation of the White County Zoning Ordinance and grounds for revoking the special exception use permit and punishable under the White County Zoning Ordinance.

1. The condition must be designed to protect natural resources, the health, safety, or welfare and the social or economic well being of those who will use the land or activity under consideration, residents and landowners immediately adjacent to the proposed land use or activity, and the community as a whole.

2. The condition must be related to the valid exercise of the police power, and purposes, which are affected, by the proposed use or activity.
3. The condition must be necessary to meet the intent and purposes of the White County Zoning Ordinance, be related to the standards established in the White County Zoning Ordinance for the land use or activity under consideration, and be necessary to insure compliance with those standards.

B. Commitments

The Area Board of Zoning Appeals may accept written commitments concerning the use or development of the property as specified under IC 36-7-4-1015 as amended from time to time.

C. Recording conditions and commitments

After review of any conditions or commitments by the Executive Director, or his or her designee, the conditions or commitments shall be recorded, by the applicant, in the White County Recorders office within ninety (90) days of approval. A copy of the recorded document shall be provided to the Executive Director for inclusion in the petition file prior to the issuance of any Improvement Location Permit.

D. Compliance with conditions and commitments

No Improvement Location Permit shall be issued for any permit application which does not comply with the recorded conditions and/or commitments.

12.5.12 Limitation

The approval of a proposed special exception use shall not authorize the development, construction, reconstruction, alteration or moving of any building or structure, but shall merely authorize the preparation, filing and processing of applications for such permits or approvals as may be required by the regulations of the County. A special exception use permit shall be deemed to authorize only the particular use at the particular location for which the special exception use was granted. Once granted, a special exception use shall run with the land, unless specifically stated otherwise in the conditions or commitments of the Board's final determination, or until such time as:

- A. The use comes into compliance with the White County Ordinance as written; or
- B. The use is terminated, in a public hearing, by the Area Board of Zoning Appeals.
- C. In addition, a special exception use approved by the Board may not be expanded, extended, or enlarged unless it is:
- D. Re-approved by the Board under the procedures set forth in this Chapter; OR
- E. Incidental as determined by the Executive director; OR
- F. Increasing the total area of structures and buildings by less than 50% of the most recently Area Board of Zoning Appeals-approved site development plan. Such authorization shall be in writing from the Executive Director.

12.5.13 Termination

A special exception use may be terminated by the Area Board of Zoning Appeals, upon filing of a complaint by an interested person or the Executive Director, and upon finding at a public hearing, with notice to the property owner and any other interested parties pursuant to Area Board of Zoning Appeal rules or By-Laws, that the terms of this Chapter or conditions of approval or commitments, have not been complied with. A special exception use permit may be terminated by the Area Board of Zoning Appeals under the following procedures.

A. Determination by the Executive Director

In the event that the Executive Director determines that possible grounds exist for the termination of a special exception use, the Executive Director shall notify the applicant, via Certified Mail, a minimum of ten (10) days, before the public hearing.

B. Public Hearing

The Area Board of Zoning Appeals may, in a public hearing, determine if grounds for termination exist. The presentation of reports and testimony and all other aspects of the public hearing shall be consistent with the By-Laws of the Board.

C. Grounds for Termination

At the public hearing the special exception use shall be revoked if a finding is made by the Area Board of Zoning Appeals that one or more of the following is true:

1. Inconsistency with the White County Zoning Ordinance

The execution of the approval is not consistent with a requirement of the White County Zoning Ordinance.

2. Inconsistency with a condition of approval

The execution of the approval is not consistent with any condition of approval

3. Inconsistency with a written commitment

The execution of the approval is not consistent with any written commitment

4. Fraud or misrepresentation of facts

The approval was the result of fraud or the misrepresentation of facts.

5. Discontinued or abandoned use

The special exception use is discontinued or abandoned for a period of twelve (12) months.

12.5.14 Appeals

Final decisions of the Area Board of Zoning Appeals under the 900 Series of IC 36-7-4 and section 1015 may be subject to judicial review as provided for in the 1600 Series of IC 36-7-4 as amended from time to time. A person must have standing to submit a petition for judicial review of a zoning decision of the Area Board of Zoning Appeals to the appropriate court. The petition shall be presented to the court not later than thirty (30) days after the date of the zoning decision that is the subject of the petition for

judicial review. A person who fails to timely object to a zoning decision or timely petition for review a zoning decision within the thirty (30) day period prescribed in this section waives the right to judicial review under this subsection. For purposes of this subsection, the following is applied:

1. "Standing" is determined as provided for in IC 36-7-4-1603 of the 1600 Series as amended from time to time.
2. "Zoning Decision" is defined in IC 36-7-4-1016 of the 1000 Series as amended from time to time.

A person may file a petition for judicial review under this section only after exhausting all administrative remedies available within the Area Board of Zoning Appeals. APPEAL of an Administrative decision

12.6 APPEAL OF AN ADMINISTRATIVE DECISION

12.6.1 Purpose

- A. The appeal procedure is provided as a safeguard against arbitrary or erroneous administrative decisions. It is intended to avoid the need for legal action by establishing local procedures to review and correct administrative errors. It is not, however, intended as a means to subvert the clear purposes, meanings, or intent of the White County Zoning Ordinance or the rightful authority of the Executive Director to enforce the requirements of the White County Zoning Ordinance. To these ends, the reviewing body shall give all proper deference to the spirit and intent embodied in the language of the White County Zoning Ordinance and to the reasonable interpretations of that language by those charged with the administration of the White County Zoning Ordinance.
- B. The filing of an appeal shall stay all proceedings in furtherance of the action appealed from, unless the Executive Director certifies to the Area Board of Zoning Appeals, after the notice of appeal has been filed, that by reason of facts stated in the certificate, a stay would cause, in his or her opinion, imminent peril to life or property, in which case the proceedings shall not be stayed otherwise than by a restraining order that may be granted by the Area Board of Zoning Appeals or by a court of record, on application, of notice to the Executive Director and on due cause shown.
- C. The Area Board of Zoning Appeals may reverse or affirm, wholly or partly, or may modify the interpretation order or final decision as in its opinion ought to be made. To that end the Area Board of Zoning Appeals has all the powers of the officer from whom the appeal is taken.

12.6.2 Authority

The Area Board of Zoning Appeals may grant an appeal of any decision, interpretation, or determination made by the Executive Director or any other administrative official or board charged with the duty of enforcing and interpreting the White County Zoning Ordinance.

12.6.3 Parties entitled to appeal

Appeals to the Area Board of Zoning Appeals concerning the interpretation or administration of the White County Zoning Ordinance may be taken by any persons aggrieved or affected by any decision of the Executive Director or any other administrative official or board charged with the duty of enforcing and interpreting the White County Zoning Ordinance.

12.6.4 Application

A person shall submit an administrative appeal application and required supporting information to the staff no later than thirty (30) days of the decision in question. The application shall be in accordance with the requirements of this Chapter. Supporting information shall include, but is not limited to, the following:

- A. Original Submittals
Copies of all materials upon which the decision being appealed was based.
- B. Written Decisions
Copies of any written decisions that are the subject of the appeal.
- C. Appeal Basis
A letter describing the reasons for the appeal noting specific situations of the White County Ordinance or other requirements upon which the appeal is based.

12.6.5 Action by the Executive Director

The Executive Director shall provide to the Board all documentation constituting the record from which the action appealed was taken.

12.6.6 Notification

Notification of public hearing as prescribed by this Chapter.

12.6.7 Possible action by the Board of Zoning Appeals

The Area Board of Zoning Appeals shall hold a public hearing in which it reviews all applicable documentation. The Area Board of Zoning Appeals shall render a written decision on the appeal. Such decision may reverse, modify (in whole or in part), affirm, or continue the appeal of the administrative action.

- A. Reverse
The administrative decision shall be reversed if Findings of Fact are made that the applicant is in compliance with the requirements of the White County Zoning Ordinance and Indiana State Code.
- B. Modify
The administrative decision shall be modified if the Area Board of Zoning Appeals determines that the proper interpretation of the provision(s) identified in the appeal is/are inconsistent with either the administrative decision or the requested interpretation of the ordinance.

C. Affirm

The administrative decision shall be affirmed if Findings of Fact are made supporting the administrative decision.

D. Continue

The appeal shall be continued based on: a request by the Executive Director or the applicant; an indecisive vote; or a determination by the Board that additional information is required prior to action being taken on the request. The continuing of all applications shall be consistent with the adopted By-Laws for the Area Board of Zoning Appeals.

12.6.8 Review by Judicial Review

Final decisions of the Area Board of Zoning Appeals under the 900 Series of IC 36-7-4 and section 1015 may be subject to judicial review as provided for in the 1600 Series of IC 36-7-4 as amended from time to time. A person must have standing to submit a petition for judicial review of a zoning decision of the Area Board of Zoning Appeals to the appropriate court. The petition shall be presented to the court not later than thirty (30) days after the date of the zoning decision that is the subject of the petition for judicial review. A person who fails to timely object to a zoning decision or timely petition for review a zoning decision within the thirty (30) day period prescribed in this section waives the right to judicial review under this subsection. For purposes of this subsection, the following is applied:

1. "Standing" is determined as provided for in IC 36-7-4-1603 of the 1600 Series as amended from time to time.
2. "Zoning Decision" is defined in IC 36-7-4-1016 of the 1000 Series as amended from time to time.

A person may file a petition for judicial review under this section only after exhausting all administrative remedies available within the Area Board of Zoning Appeals.

12.6.9 Right to grant variance in deciding appeals

In any case where the application for appeal is accompanied by an application for a variance in accordance with the White County Zoning Ordinance, the Area Board of Zoning Appeals shall notice, hear, and decide to grant or deny, such variance in compliance with the provisions of this Chapter.

12.6.10 Conditions and limitations on rights granted by appeal

In any case where the White County Zoning Ordinance imposes conditions and limitations upon any right, any such right granted by appeal shall be subject to such conditions and limitations in the same manner and to the same extent as if secured without the necessity of an appeal.

12.7 ZONING ORDINANCE AMENDMENT

12.7.1 Purpose

The purpose of this Section is to provide standards and procedures for making amendments to the text of the White County Zoning Ordinance that are of general

significance or application. This amendment process is not intended to relieve particular hardships nor to confer special privileges or rights upon any person, but only to make adjustments necessary in light of changing community conditions, changes in public policy, fact of law or cultural changes recognized by the Board.

12.7.2 Authority

The text of the White County Zoning Ordinance may be amended from time to time by the passage of an Ordinance duly adopted by the appropriate legislative body in accordance with the Rules of Procedure of the White County Area Plan Commission and the appropriate legislative body.

12.7.3 Parties entitled to initiate amendments

Amendments to the White County Zoning Ordinance may be initiated by the Staff, the Area Plan Commission or a legislative body.

12.7.4 Approval

Regardless of whether an amendment is initiated by the Executive Director, Area Plan Commission or legislative body, the application must first go to the Area Plan commission for consideration before any action can be taken by the legislative body.

Any amendment initiated will be heard at a public meeting within sixty (60) days of the proposed amendment being filed with the Staff.

Within ten (10) business days after the Area Plan Commission determines its recommendation, if any, the Staff shall certify the proposal to each participating legislative body with a favorable, unfavorable or no recommendation.

The legislative body shall vote on the proposal within ninety (90) days after the Plan Commission certifies the proposal to said body.

A. Proposals which receive a favorable recommendation

1. At the first regular meeting of the legislative body after the proposal is certified (or at any subsequent meeting with the ninety (90) day period), the legislative body may adopt, reject or amend the proposal. The legislative body shall give notice under IC 5-14-1.5-5 of its intention to consider the proposal at that meeting.
 - a. If the legislative body adopts the proposal as certified, it takes effect as other ordinances of the legislative body.
 - b. If the legislative body fails to act on the proposal within ninety (90) days after certification, it takes effect as if it had been adopted as certified.
 - c. If the legislative body rejects or amends the proposal, it shall be returned to the Plan Commission for its consideration with a written statement of the reasons for the rejection or amendment. The Commission has forty-five (45) days in which to consider the rejection or amendment and report to the legislative body as follows:
 1. If the Commission approves the amendment or fails to act within the forty-five (45) day period, the ordinance stands as passed by the

legislative body and it takes effect on the date of approval or the end of the forty-five (45) day period.

2. If the Commission disapproves the rejection or amendment, the action of the legislative body on the original rejection or amendment stands only if confirmed by another vote of the legislative body within forty-five (45) days after certification of its disapproval. If the legislative body fails to act within the forty-five (45) days after the Commission certifies its disapproval, the amendment passes as originally certified.

B. Proposals which receive an unfavorable or no recommendation

1. At the first regular meeting of the legislative body after the proposal is certified (or at any subsequent meeting within the ninety (90) day period), the legislative body may adopt, reject or amend the proposal. The legislative body shall give notice under IC 5-14-1.5-5 of its intention to consider the proposal at that meeting.
 - a. If the legislative body adopts the proposal as certified, it takes effect as other ordinances of the legislative body.
 - b. If the legislative body fails to act on the proposal within ninety (90) days after certification, it takes effect as if it had been adopted as certified.
 - c. If the legislative body rejects the proposal or fails to act on it within ninety (90) days after certification, it is defeated.
 - d. If the legislative body amends the proposal, it shall be returned to the Plan Commission for its consideration, with a written statement of the reasons for the amendment. The Commission has forty-five (45) days in which to consider the rejection or amendment and report to the legislative body as follows:
 1. If the commission approves the amendment or fails to act within forty-five (45) day period, the ordinance stands as passed by the legislative body and it takes effect on the date of approval or the end of the forty-five (45) day period.
 2. If the Commission disapproves the rejection or amendment, the action of the legislative body on the original rejection or amendment stands only if confirmed by another vote of the legislative body within forty-five (45) days after certification of its disapproval. If the legislative body fails to act within the forty-five (45) days after the Commission certifies its disapproval, the amendment passes as originally certified.

Once adopted, the amendment must be signed and attested. The Staff will see that the County Commissioners adoption is recorded.

12.8 ZONING MAP AMENDMENT (REZONING)

12.8.1 Purpose

The purpose of this Section is to provide standards and procedures for making amendments to the Zoning Map that are of general significance or application. This amendment process is not intended to relieve particular hardships nor to confer special

The letter must be signed by at least one of the property owners, dated and notarized by a licensed notary. This letter will become a part of the official record and stands until such time as the rezone request has received final action by the appropriate legislative body.

12.8.4 Application

The applicant shall submit a rezoning application, a legal description for the property or properties, the required filing fee, and any supporting documentation to the office of the Area Plan Commission. Supporting documentation includes, but is not limited to the following:

A. Site Plan

A conceptual site plan showing all features relevant to the application.

B. Letter of Intent

A letter of intent to the Plan Commission stating the reasons for the rezoning, including a detailed description of any proposed development for which the rezoning is sought. The letter should include any written commitments being made by the applicant.

12.8.5 Notification

Notification of public hearing will be as prescribed by this Chapter.

12.8.6 Public hearing

The Area Plan Commission shall hold a public hearing on the application in accordance with the Commission's Rules of Procedure and as prescribed by the White County Zoning Ordinance. The public meeting shall be held on a date consistent with the published Calendar of Filing and Meeting Dates, provided that the meeting is no later than 60 days upon receipt of a complete application packet and filing fee. The presentation of reports and testimony and all other aspects of the public hearing shall be consistent with the Area Plan Commission's Rules of Procedure.

12.8.7 Decision criteria

The wisdom of amending the Zoning Map is a matter committed to the sound legislative discretion of the appropriate legislative body and is not controlled by any one (1) standard or district. The Area Plan Commission should, in determining whether to favorably recommend, unfavorably recommend, or forward with no recommendation consider the following:

A. Planning efforts

Whether the proposed rezoning is consistent with the goals, objectives, and policies of the White County Strategic Plan and any other applicable planning studies and reports, as adopted and amended from time to time;

B. Current conditions

Whether the proposed rezoning is compatible with current conditions (e.g. existing lots, structures and uses) and the overall character of existing development in the immediate vicinity of the subject property;

C. Desired use

Whether the proposed rezoning is the most desirable use for which the land in the subject property is adapted;

D. Property values

Whether the proposed rezoning will have an adverse effect on the value of properties throughout the jurisdiction; and

E. Responsible growth

Whether the proposed rezoning reflects responsible standards for growth and development.

Regardless of whether a rezone request is initiated by the property owner, the Area Plan Commission or the legislative body, the proposal must be referred to the Area Plan Commission for consideration and recommendation before any final action is taken by the legislative body.

12.8.8 Possible action by the Area Plan Commission

Within sixty (60) days after receipt of the rezoning application, the Area Plan Commission shall hold a hearing at which they will determine a favorable recommendation, an unfavorable recommendation, or no recommendation, or the Commission may continue the request.

A. Favorable recommendation

The application shall be forwarded with a favorable recommendation if it is found to be consistent with the decision criteria listed sub-section 12.8.7 above. The recommendation may include written commitments proposed by the applicant and/or requested by the Plan Commission.

B. Unfavorable recommendation

The application shall be forwarded with an unfavorable recommendation if it is found to be inconsistent with the decision criteria listed in sub-section 12.8.7above.

C. No recommendation

The application may be forwarded with no recommendation if, by a majority vote of the Commission, it is determined that the application includes aspects that the Commission is not able to evaluate.

D. Continued

The application may be continued by the Commission based on a request by the Executive Director, an applicant, a remonstrator, or other interested party; an indecisive vote; or a determination by the Commission that additional information is required prior to action being taken on the request. An applicant or

remonstrator may request only one (1) continuance; petitions may be continued as needed by the Executive Director, or the Area Plan Commission.

12.8.9 Certification by the Area Plan Commission

Within ten (10) business days of its determination, the Staff shall certify the Commission's recommendation (including no recommendation) to the appropriate legislative body, by resolution in accordance with IC 36-7-4-608 as amended.

12.8.10 Possible action by the appropriate legislative body

The legislative body shall vote on the proposal within ninety (90) days after the recommendation of the Area Plan Commission has been certified to the legislative body.

- A. Proposals certified with a favorable recommendation
 - 1. If the legislative body adopts the proposal as certified, it takes effect as other ordinances of the legislative body.
 - 2. If the legislative body rejects the proposal, it is defeated,
 - 3. If the legislative body fails to act on the proposal within ninety (90) days after certification, the ordinance takes effect as if it had been adopted as certified ninety (90) days after certification.
- B. Proposals certified with either an unfavorable recommendation or no recommendation
 - 1. If the legislative body adopts the proposal as certified, the rezone is defeated.
 - 2. If the legislative body rejects the proposal, the rezone is granted.
 - 3. If the legislative body fails to act on the proposal within ninety (90) days after certification, the rezone is defeated.

12.8.11 Effective date

An amendment to the zoning map shall become effective immediately upon adoption by the appropriate legislative body, provided that there are no written commitments. Zoning map amendments with commitments shall become effective as provided for in Section 12.8.12 (B) of this Chapter.

12.8.12 Written commitments

Consistent with IC 36-7-4-1015 as amended, the applicant in any rezoning application may make written commitments regarding the use or development of that parcel. Written commitments may also be initiated by the Plan Commission or appropriate legislative body.

A. Consideration of Commitments

All commitments shall be considered by the Area Plan Commission and the appropriate legislative body in the review of the rezoning application. Any deletion or modification of the written commitments by the appropriate legislative body shall be referred back to the Area Plan Commission for ratification only if such deletion or modification makes the commitment less stringent.

1. Area Plan Commission Ratifies

If the Commission ratifies the modification(s) to the commitments, the rezoning ordinance adoption is complete.

2. Area Plan Commission Disagrees

If the Commission disagrees with the modification(s) to the commitments, the Commission shall forward its reasoning, in writing, to the appropriate legislative body. The rezoning, including the modified commitments, shall take effect if the appropriate legislative body again votes for its adoption.

- B. Documentation of Commitments

The rezoning ordinance shall not become effective until the written commitments are recorded. The written commitments shall be recorded along with the rezoning ordinance, by the applicant, in the office of the White County Recorder within ninety (90) days of the adoption of the rezoning ordinance. A recorded copy of the commitments shall be provided to the Executive Director for inclusion in the application file within that same ninety (90) day time period. The adoption of the rezoning ordinance shall not take effect and shall be void if the commitments and rezoning ordinance are not recorded in the ninety (90) day time period.

- C. Enforcement of Commitments

The written commitments shall be binding on the property owner making the commitment. The written commitments, once recorded, shall be binding on the owner of the subject property, any subsequent owners of the subject property, and any person or entity that acquires an interest in the subject property, or portion thereof. The written commitments shall be enforceable by the Area Plan Commission or Executive Director consistent with the provisions of the White County Zoning Ordinance.

- D. Modification of the adopted written commitments

Except for a commitment that expires or automatically terminates as provided for within the commitment, a commitment may be modified or terminated only by a decision of the Area Plan Commission or Area Board of Zoning Appeals, to whichever the commitment was made.

12.9 ZONING ORDINANCE INTERPRETATION

The interpretation authority established by this Chapter is intended to recognize that the provisions of the White County Zoning Ordinance, though detailed and extensive, cannot, as a practical matter, address every specific situation to which they may have to be applied. Many such situations can be readily addressed by an interpretation of the specific provisions of the White County Zoning Ordinance in light of the general and specific purposes for which those provisions have been enacted. Because the interpretation authority established is an administrative rather than a legislative authority, it is not intended to add to or change the essential content of the White County Zoning Ordinance, but is intended only to allow authoritative application of that content to specific cases.

12.9.1 Authority

The Executive Director or his/her designee, subject to the procedures, standards, and limitations of this Chapter may, by written order, render interpretations, including use interpretations, of the provisions of the White County Zoning Ordinance and of any rule or regulation issued pursuant to it.

12.9.2 Parties entitled to seek interpretations

Applications for interpretations may be filed by any person having a legal or equitable interest in a property that gives rise to the need for an interpretation, provided that interpretations shall not be sought by any person based solely on hypothetical circumstances or where the interpretation would have no effect other than as an advisory opinion.

12.9.3 Application Requests

Requests for Interpretations of the White County Zoning Ordinance shall be filed with the Executive Director of the Area Plan Department.

12.9.4 Decision criteria

In taking action on all ordinance interpretation requests, the Executive Director shall use the following decision criteria.

- A. Any use defined in Chapter 14, Definitions, of the White County Zoning Ordinance shall be interpreted as therein defined;
- B. No use interpretation shall permit any use in any district unless evidence shall be presented that demonstrates that it will comply with the general district regulations established for that particular district;
- C. No use interpretation shall permit any use in a district unless such use is similar to other uses permitted in the district and is more similar to those uses than to uses permitted in a less restrictive district;
- D. If the proposed use is most similar to a use permitted only as a special exception in the district in which it is proposed to be located, then any use interpretation permitting such use shall be conditioned on the issuance of a special exception use permit, pursuant to this Chapter, for such use;
- E. No use interpretation shall permit the establishment of any use that would be inconsistent with the statement of purpose of the district in question.

12.9.5 Possible action by the Executive Director

Within ten (10) working days following the receipt of a written ordinance interpretation request, or within a longer period of time mutually acceptable to both parties, the Executive Director shall inform the applicant, in writing, of his/her interpretation, stating the specific precedent, reasons, and analysis upon which the determination is based. Failure of the Executive Director to act within ten (10) working days, or the mutually agreed upon time, shall be deemed to be a decision denying the request.

12.9.6 Recording

A record of all requests for interpretations, and the interpretation itself shall be kept on file in the office of the Area Plan Commission.

12.9.7 Limitations on use interpretations

Subject to an extension of time granted by the Executive Director, no use interpretation shall be valid for a period longer than twelve (12) months from the date of issuance. An interpretation finding a use to be permitted, or permitted as a special exception use in a particular district, shall be deemed to authorize only the particular use for which it was issued and such permit shall not be deemed to authorize any allegedly similar use for which a separate use interpretation has not been issued.

12.9.8 Appeals

Appeals of interpretations rendered by the Executive Director may be taken to the Board of Zoning Appeals as prescribed by this Chapter.

12.10 PLANNED UNIT DEVELOPMENT

As prescribed by Chapter 5, Planned Unit Development of the White County Zoning Ordinance.

12.11 IMPROVEMENT LOCATION PERMIT

No structure shall be erected, moved, added to, or structurally altered without an Improvement Location Permit issued by the Area Plan Staff unless specifically exempted elsewhere in this Ordinance. No Improvement Location Permit shall be issued by Staff except in conformance with the provisions of this Chapter, unless by written order from the Board of Zoning Appeals or Hearing Officer in the form of an administrative appeal, Special Exception Use, or Variance as provided by the White County Zoning Ordinance.

12.11.1 Improvement Location Permit required

An Improvement Location Permit shall be obtained for any of the following actions. A single Improvement Location Permit may be issued for a combination of these actions, if they are applied for simultaneously:

A. New construction – Principal Structure

Construction of, additions to, alterations of, placement of or re-location of any principal structure excluding normal & routine maintenance

B. Construction of towers, turbines, antennas, dishes, similar structures

Construction or modification of any wind turbine, communication, meteorological or WECS tower, antenna (excluding antennas for residential uses), flag poles, poles to which sirens or other similar devices are attached, or satellite dish (with a diameter greater than two (2) feet).

C. Remodel

Remodel of any existing structure which affects any development standard specified in Appendix B.

- D. Alteration of required landscaping
Removal of required trees and plants within buffer yards and landscaping areas required by the White County Zoning Ordinance
- E. Alteration of off-street parking
Construction and/or redesign of an off-street parking area, excluding agricultural uses and single and two-family residential uses
- F. Placement of a manufactured or mobile home other than in an Indiana State Regulated Mobile Home Park.

12.11.2 Improvement Location Permit not required

No Improvement Location Permit shall be required for the following types of improvements. Such improvements shall comply with any applicable requirements of the White County Zoning Ordinance, the White County Subdivision Control Ordinance, and any other applicable regulations of White County or the appropriate legislative body unless specifically exempted in this Ordinance:

- A. Accessory structures 120 square feet or less;
- B. Sidewalks, steps/stairs, retaining walls and patios (exempt from setback specifications provided for in Appendix B, Bulk Use Standards);
- C. Non-structural, cosmetic changes to any structure including the replacement of windows in existing openings, re-roofing without a roof-line change, the installation of siding material, and repainting.
- D. Tents, temporary commercial structures, non-permanent or portable concession stands (exempt from setback specifications provided for in Appendix B, Bulk Use Standards);
- E. Piers, boat docks and boat houses (exempt from setback specifications provided for in Appendix B, Bulk Use Standards);
- F. Grain legs and portable grain dryers (exempt from setback specifications provided for in Appendix B, Bulk Use Standards);
- G. Mailbox and Newspaper holders and structures (exempt from setback specifications provided for in Appendix B, Bulk Use Standards);
- H. Seasonal ornaments (exempt from setback specifications provided for in Appendix B, Bulk Use Standards);
- I. Yard ornaments and landscaping (exempt from setback specifications provided for in Appendix B, Bulk Use Standards);
- J. Children's playground equipment (exempt from setback specifications provided for in Appendix B, Bulk Use Standards);
- K. Air conditioning, heating and power generators utilized as an attached accessory to a principal structure and which is a minimum of 2' from any property line (exempt from setback specifications provided for in Appendix B, Bulk Use Standards), and,

- L. Satellite Dish Antennas (Two (2) feet or less in diameter) (exempt from setback specifications provided for in Appendix B, Bulk Use Standards);

12.11.3 Application

Each application for an Improvement Location Permit shall be accompanied by these supporting documents as required by the Executive Director to be deemed a complete application.

- A. Site Plan
As prescribed by the White County Zoning Ordinance or as required by the Staff
- B. Waste disposal verification (if applicable)
Health department approval for any sewage disposal or water supply, where applicable
- C. Use description
A description of any existing and proposed uses of the property
- D. Dwelling units/tenant spaces (if applicable)
An indication of the number of dwelling units, or tenant spaces, the building(s) are intended to accommodate.
- E. Other
Such other information, as may be required by the Area Plan Commission's Executive Director for proper enforcement of the White County Zoning Ordinance.

12.11.4 Action by the Executive Director (and/or his or her designee)

The Executive Director, and/or his or her designee, shall approve, conditionally approve, or disapprove the application based on the following criteria.

- A. Approved
If the application is approved, the Staff shall issue a placard to the applicant. The placard is to be posted in a conspicuous place on the property in question and will attest to the fact that the plans for construction or alteration are in compliance with the provisions of the White County Zoning Ordinance.
- B. Conditionally approve
If after receipt of a complete application for an Improvement Location permit, the Staff finds that the applicant has not fully met the standards set in the White County Zoning Ordinance, and the changes or additional actions needed are deemed by the Staff to be relatively minor or simple, the Staff may issue a conditional approval stating the conditions which must be met prior to the issuance of an Improvement Location Permit, and the reasons for such changes clearly stated in writing. If the applicant agrees, in writing, to the conditions of approval,

the application is amended accordingly. If the applicant does not agree to the conditions, the application is denied.

C. Disapproved

If the application is disapproved, the Staff shall notify the applicant indicating the reasons for the disapproval.

12.11.5 Expiration of an Improvement Location Permit

A. Initiation of work

If the work described in any Improvement Location Permit has not begun within three (3) years from the date which the first application related to the project was filed, the permit shall expire; and shall be canceled by the Area Plan Commission or its Staff.

B. Completion of work

If the work described in any Improvement Location Permit has not been completed within ten (10) years of the date in which the first application related to the project was filed, the permit shall expire and be canceled by the Area Planning Commission or its Staff and written notice thereof shall be given to the persons affected, together with notice that future work as described in the canceled permit or an extension shall not proceed unless and until a new Improvement Location Permit has been obtained.

12.11.6 Failure to obtain an Improvement Location Permit

The failure to obtain an Improvement Location Permit as required by the White County Zoning Ordinance shall be deemed a violation of the White County Zoning Ordinance and subject to the provisions of Chapter 13, Enforcement. Where an Improvement Location Permit is required, any person or persons who initiate location, construction or alteration of a structure prior to obtaining an Improvement Location Permit or any other required permit shall be subject to the fines and penalties of the White County Zoning Ordinance.

12.11.7 Limitations

Improvement Location Permits issued on the basis of plans and applications approved by the Staff authorize only the use or arrangement set forth in such approved application or amendments, and no other use, arrangements, or construction is permitted. Any use, arrangement, or construction contrary to that authorized shall be deemed a violation of the White County Zoning Ordinance and subject to the provisions of Chapter 13, Enforcement.

12.11.8 Recording

Every Improvement Location Permit issued pursuant to this Chapter shall be kept on file in the office of the Area Plan Commission for the period as specified by Indiana State Code and shall be available as public record.

12.12 CERTIFICATE OF OCCUPANCY PERMIT

It shall be unlawful to use or occupy, or to permit the use or occupancy of any building or premises, or both, or part thereof hereafter created, erected, changed, converted, or wholly or partly altered or enlarged in its use or structure until a Certificate of Occupancy has been issued by the Building Inspector. The Certificate of Occupancy shall state that the proposed use of the building and/or land conforms to the requirements of the White County Zoning Ordinance and that the Building Inspector or his/her representative has inspected the property and attested to that fact.

12.12.1 Issuance and recording

The issuance and recording of a Change of Occupancy Permit shall be in conformance with the White County Building Code administered by the White County Building Department.

12.12.2 Failure to obtain a Certificate of Occupancy Permit

It shall hereby be declared unlawful and in violation of the provisions of this Chapter for any builder or property owner to allow any structure to become occupied prior to the following:

- A. Obtaining a building permit from the Building Department
- B. Obtaining an Improvement Location Permit from the Staff
- C. Passing a final inspection by the Building Inspector
- D. Receiving a Certificate of Occupancy Permit from the Building Inspector or his/her representative

12.13 SITE DEVELOPMENT PLAN REVIEW

12.13.1 Purpose

Site development plan review is required to promote orderly development and redevelopment in the County and to ensure that such development is in harmony with surrounding properties and consistent with the general welfare and the policies in the Comprehensive Plan. The procedures set forth in this Chapter are used for determining whether new development or redevelopment is in compliance with the standards of the White County Zoning Ordinance. This Section provides standards by which submission and approval of site plans, for access control, lighting, signage, and landscaping of a lot or parcel of land are submitted in a manner which achieves the following purposes:

- A. Compatibility of land uses, buildings and structures;
- B. Protection and enhancement of property values;
- C. Efficient use of land;
- D. Minimization of traffic to promote safety; and
- E. Minimization of environmental problems.

12.13.2 Applicability and authority

- A. Site development plan review shall be required for any agricultural, commercial, industrial, multi-family, amusement and entertainment park developments, and condominiums prior to the issuance of an Improvement Location Permit or a Building Permit for the following development situations:
1. Any new principal structures;
 2. An existing principal structure is proposed to be expanded more than twenty-five (25) percent of the gross area of the existing structure;
 3. Any new or modified building and/or site improvements for a zoning lot that has previously received site development plan approval under the White County Zoning Ordinance. Re-approval of the plan is required for components of the plan, which depart from the approved site development plan. The extent of required documentation of any proposed changes to be incorporated in the submittal for re-approval shall be determined by the Executive Director;
 4. Any new or modified off-street parking or loading area improvements;
 5. A site development plan shall not be required solely because of a change in the use except where such change of use results in increased off-street parking requirements that cannot currently be met on the site.
 6. In accordance with Chapter 2, District Boundaries and Standards, of the White County Zoning Ordinance no building or structure which has been damaged by fire, explosion, or act of God to the extent of more than fifty (50) percent of its assessed value, shall be restored except in conformity with the regulations of the District in which it is located.
- B. Site development plans may be approved by the Staff in accordance with the procedural provisions of this Section. Any site development plan requiring a variance shall not receive an Improvement Location Permit until approval of the variance is granted by the Area Board of Zoning Appeals.

12.13.3 Initiation

A request for site development plan approval may be made by the owner or owners representative intending to request an Improvement Location Permit under the requirements of this Section.

12.13.4 Submission

The owner of the property or a duly authorized representative of the owner shall file a site development plan for approval with the Staff.

12.13.5 Content Requirements

All documents and information submitted as part of an application for site development plan approval constitute a statement by the applicant, property owner and developer/contractor that he or she intends and agrees to be bound to develop in accordance with such information upon approval. Site development plans shall include the following information unless waived or modified by the Executive Director:

- A. Contact information for the applicant and owners
- Name, address and telephone number of the applicant, including the name and address of each person or entity owning an interest in the applicant or owner and the extent of such ownership interest unless any of such entities is a corporation or a partnership, in which case only those persons owning an interest in excess of ten (10) percent in such corporation or partnership need to be identified by name, address and extent of interest. For purposes of this Section the term ownership interest shall include any legal or equitable interest held at the time of application in the real property which is the subject of the application. The application shall include the signatures of the owner(s). Completed application form provided by the Office of the Area Plan Commission, the property owner and the developer/contractor. In the case where an applicant or owner is a corporation or non-profit group, a contact name, address and phone number must be included.
- B. Each application shall include the required number of full sized documents and drawings as prescribed by this Chapter, to the Office of the Area Plan Commission at the time the application is filed.
- C. The names and addresses of persons and/or firm responsible for preparing the plan.
- D. A site plan drawing including the following:
1. Date, north point and scale;
 2. The dimensions of all lot and property lines, showing the relationship of the subject property to abutting properties and buildings within fifty (50) feet or one property owner deep, whichever is less;
 3. Boundary lines of adjacent tracts of land, showing owners of record;
 4. Legal description of the parcel;
 5. Existing and proposed easements;
 6. The location of existing and/or proposed fire hydrants;
 7. For a site which includes existing structures or improvements, an indication of those improvements that are to remain and those which will be removed;
 8. Underground storage tanks, if any;
 9. General alignment and lengths of all streets and all property lines;
 10. All building restriction lines, highway setback lines, easements, covenants, reservations and rights-of-way;
 11. Streets, using the classification in the Subdivision Control Ordinance: alleys; easements and utilities, including street lighting and underground conduits for street lighting;
 12. Driveways, entrances, exits, parking areas and sidewalks;
 13. Calculations of the following, as applicable:

- a. Number of dwelling units or square footage of non-residential uses;
 - b. Number of parking spaces; and
 - c. Number of loading spaces.
14. Project name by which the project shall be legally or commonly known.
 15. Location, widths, and type of construction of all existing and proposed streets, street names, alleys, or other public ways and easements, railroad and utility rights-of way or easements, parks, wooded areas, cemeteries, water courses, drainage ditches, swamps, low areas subject to flooding, permanent buildings, bridges, and other data considered pertinent by the Area Plan Commission or the Executive Director for the subject land, and within fifty (50) feet or one property owner deep of the proposed project, whichever is less;
 16. Existing and proposed water mains, storm sewers, sanitary sewers, culverts, bridges, and other utility structures or facilities within, adjacent to, or serving the subject land, including pipe sizes, grades, and exact locations, as can best be obtained from public or private records;
 17. Existing zoning of the land and all adjacent lands;
 18. Existing and proposed contours based on United States Geological Survey (USGS) datum with intervals of not more than five (5) feet where the slope is greater than ten percent (10%) and not more than two (2) feet where the slope is less than ten percent (10%). Elevations shall be based on sea level datum;
 19. The water elevation at the date of the survey of lakes, streams, or swamps within the project affecting it, as well as the approximate high and low water elevation of such lakes, streams, or swamps. The plan shall also show the contour line of the regulatory flood (100-year flood) elevation. All elevations shall be based on sea level datum;
 20. A statement of the proposed uses, stating the type and size of buildings, and the type of business, commercial or industry, so as to reveal the effect of the project on traffic, fire hazards, or congestion of population;
 21. Statement of proposed starting and completion dates for the project, including any proposed phasing and sequencing;
 22. Radii, internal angles, points of curvature, tangent bearings and lengths of all arcs, chords and chord bearings;
 23. Accurate location of all survey monuments erected, corners, and other points established in the field in their proper places; and
 24. Supplementary explanation of the specific type(s) of activities proposed on the site. Such information shall include, but is not limited to:
 - a. Estimated number of employees, resident shoppers, residents, etc;
 - b. Hours of operation;

- c. Any changes anticipated in terms of dust, odor, smoke, fumes, noise, light, hazardous or noxious fumes, wellhead protection, etc;
 - d. Modifications to vegetative cover, drainage patterns, earth work, problem areas;
 - e. Any ancillary improvements that the applicant proposed to remedy or prevent problems created by the development; and
 - f. Draft version of any design guidelines, if applicable.
- E. Landscaping shall be in accordance with the requirements in Chapter 9, Landscaping Standards.
- F. Other information that may reasonably be required by the Executive Director to adequately assess the proposal which may include:
- 1. A report examining the estimated impacts of the proposed development on the school district or a letter from the school district outlining its estimates of the impacts of the proposed development;
 - 2. Estimated impacts on and capabilities of emergency services, including but not limited to, fire, police and emergency medical services, and their respective response time;
 - 3. An examination of the impacts of the proposed development on available recreational facilities, as well as any proposed mitigation measures;
 - 4. An examination of impacts to utilities servicing the facilities, such as water, sewer, gas, electrical, communication, and other utilities.
 - 5. A report examining the fiscal impacts of the project, both positive and negative.
 - 6. A traffic study examining the impacts of development of the highest acceptable use, as well as any new roads/intersections on current and projected traffic flow and level-of-service.
 - 7. IDEM permit application materials.

12.13.6 Administrative procedures

- A. Applications
- Applications shall be filed with the Staff in conformance with the regulations set forth in this Chapter.
- B. Special requests
- In addition to the minimum data and information required by this Section, every applicant shall submit such other additional data, information, or documentation as the Executive Director or any body before which its application is pending may deem necessary or appropriate to achieve a full and proper consideration of that application.
- C. Supplemental data

Whenever supplemental data in connection with a previously filed application is required by the County or offered by the applicant, it shall be submitted as prescribed by the Calendar of Meetings and Filing Dates. The filing of such data shall, at the discretion of the Executive Director and of the body hearing the application, be cause to delay a requested or scheduled hearing or decision date.

D. Fees

Every application must be accompanied by a fee, as prescribed by the Official Fee Schedule.

12.13.7 Notice

To be provided in accordance with this Chapter.

12.13.8 Action on site development plans

If the site development plan meets all the requirements of this Chapter, the application shall be approved.

If the development plan does not meet all the requirements of this Chapter, the County's Zoning Ordinance, Subdivision Ordinance, other applicable County Ordinances and special items raised during the review of the application, the application may be denied.

If minor corrections to the site development plan are necessary for it to meet the standards set for approval, and such minor corrections can be clearly noted, then such conditions may be noted and approval of the application may be given. Revised drawings shall be submitted to the Executive Director prior to issuance of an Improvement Location Permit.

If the Area Plan Commission finds the site development plan to be incomplete with respect to necessary information, the Area Plan Commission may continue action on the site development plan until the required additional information is provided.

12.13.9 Standards for site development plan review

In reviewing and determining whether to approve or disapprove a site development plan, the Executive Director shall consider any of the following criteria applicable to development of the site:

- A. The application shall comply with the provisions of the White County Zoning Ordinance and other ordinances of the County.
- B. The plan shall be in reasonable conformity with the Comprehensive Plan.
- C. Reasonable provision shall be made to ensure that development will be served by essential public facilities and services such as highways, streets, parking spaces, police and fire protection, drainage structures, refuse disposal, water, sewers or septic, and schools.
- D. Any building or structure shall be reasonably accessible to fire, police, emergency and service vehicles. When deemed necessary for access, emergency vehicle easements shall be provided. The access for fire, police and emergency vehicles shall be unobstructed at all times.

- E. Adequate provision shall be made to ensure the compatibility of the proposed development, including mass, scale, site layout, and site design with the character of the surrounding property and the neighborhood, including:
 - 1. Relationships of buildings to sites
 - a. The site shall be planned to achieve a desirable transition to the street, provide for adequate planting, safe pedestrian movement and off-street parking areas.
 - b. Parking areas should include innovative ways to significantly screen the parking areas from views from public ways in accordance with Chapter 9, Landscaping Standards.
 - c. Without restricting the permissible limits of the applicable zoning district, the height and scale of each building shall be compatible with its site and existing (or anticipated) adjoining buildings.
 - 2. Signs
 - a. All signs shall be in conformance with the provisions of Chapter 10, Sign Standards.
- F. Open space provided is configured to make that open space usable, functional, and appropriate to the development proposed.
- G. Streets and sidewalks shall, insofar as reasonably practical, provide access and good traffic circulation to and from adjacent lands, existing streets and sidewalks.
- H. Provision shall be made to ensure that adequate access roads or entrance or exit drives will be provided and will be designed and improved so as to prevent traffic hazards or problems and to minimize traffic congestion in public streets.
- I. Adequate provision shall be made to ensure that the vehicular circulation elements of the proposed development will not create hazards to the safety of vehicular or pedestrian traffic on or off the site, disjointed vehicular or pedestrian circulation paths on or off the site, or undue interference and inconvenience to vehicular and pedestrian travel.
- J. Adequate water mains and fire hydrants shall be provided in accessible places in accordance with good fire fighting and fire prevention practice.
- K. Adequate provision shall be made for the collection and disposition of all on- and off-site storm water and natural water, including but not limited to on-site drainage retention facilities.
- L. Adequate provision shall be made for the collection and disposition of sanitary sewage.
- M. Adequate provision shall be made to avoid an increase in hazard to adjacent property from flood, increased run-off or water damage.
- N. Adequate provision shall be made to avoid glare of vehicular and stationary lights that would affect the established character of the neighborhood, and to the extent

such lights will be visible across from any property line, the performance standards for illumination shall be met.

- O. Adequate provision shall be made to ensure that the location, lighting and type of signs and the relationship of signs to traffic-control is appropriate for the site and will not have an adverse affect on any adjacent properties.

12.13.10 Conditions on plans

In considering any site development plan, the Area Plan Commission and/or Executive Director may establish reasonable and appropriate conditions upon the approval of a site development plan.

12.13.11 Public improvement performance guarantees

To ensure compliance with any condition(s) imposed under this Chapter, the Area Plan Commission may require that a cash, certified check, irrevocable bank letter of credit, or surety bond acceptable to the County, equaling one hundred ten (110) percent of the estimated cost of completion of the required public improvements, be deposited with the County to ensure faithful completion of the improvements and also be subject to the following:

- A. The performance guarantee shall be deposited prior to the onset of any construction, clearing of land or earth moving related to the site development plan. The County may establish procedures whereby a rebate of any cash deposits in reasonable proportion to the ratio of work completed on the required improvements will be made as work progresses. Any partial release of funds shall be less than ten (10) percent which shall be retained by the County until all work has been completed and subsequently inspected and approved by the County or its agents. This does not relieve the applicant from satisfying all applicable maintenance warranties and/or guarantees necessary to ensure the proper functioning of said public improvements.
- B. For the purposes of administering and enforcing this Section, "improvements" shall mean those features and actions associated with a project which are considered necessary by the County Commissioners, to protect natural resources, or the health, safety, and welfare of the residents of the County and future users or inhabitants of the proposed project or project area, including roadways, lighting, utilities, sidewalks, screening, landscaping, and surface drainage. Improvements do not include the entire project, which is the subject of development plan approval.

12.14 WRITTEN COMMITMENTS

12.14.1 Purpose, intent, and authority

1. This Section grants authority to the Area Plan Commission and the Area Board of Zoning Appeals to allow or require specific development commitments in compliance with IC 36-7-4-1015. .

12.14.2 Commitments for rezoning or PUD proposal

- A. The Area Plan Commission may require or allow a written commitment either for a proposal for a zoning map change or proposal for a PUD district ordinance, or for both of these proposals, to the extent allowed by applicable law.
- B. If the appropriate legislative body adopts (as certified) the proposal for PUD district ordinance for which the Area Plan Commission required or allowed the written commitment, then the owner of the parcel shall record or cause the commitment to be recorded before the rezoning or PUD district ordinance can become effective.
- C. Once the commitment is recorded, the commitment may be modified or terminated only by a decision of the Area Plan Commission made at a public hearing after notice as provided by this Chapter. The request for modification or termination may be initiated by the property owner or by the Area Plan Commission. The Area Plan Commission may approve or disapprove modification or termination to the extent allowed by applicable law. However, pursuant to IC 36-7-4-615(b) as amended, a commitment required or allowed for a rezoning or PUD district ordinance terminates if the zoning for the parcel changes in the future.
- D. The enforcement provisions set forth in Chapter 13, Enforcement, apply to commitments for proposals for zoning map change and PUD district ordinances.
- E. The form of commitments for proposals for zoning map change and PUD district ordinances shall be as determined by the Area Plan Commission.

12.14.3 Standard forms

- A. The Area Plan Commission may adopt written commitment forms as the standard forms for written commitments which are permitted or required by the Area Plan Commission, including written commitments for site development plans, zoning map changes, and PUD district ordinances.
- B. The Board of Zoning Appeals may adopt written commitment forms as the standard forms for written commitments, which are permitted or required by the Board of Zoning Appeals.
- C. If adopted, the appropriate standard form shall be used whenever a written commitment is permitted or required by the Area Plan Commission or Area Board of Zoning Appeals. When necessary, the standard forms may be modified in order to form the type of commitment needed and not already provided for in one of the standard forms. However, the basis of the standard forms shall be used, with the content modified only as needed to conform to the type of commitment permitted or required. An otherwise modified form may be rejected by a majority vote of the Area Plan Commission or Board of Zoning Appeals (whichever body permitted or required the commitment).

12.14.4 Binding effect

- A. Unless modified or terminated as described in this Chapter, a written commitment that is permitted or required by the Area Plan Commission or Area Board of Zoning Appeals and recorded is binding on:

1. The owner of the parcel;
 2. A subsequent owner of the parcel; and
 3. A person who acquires an interest in the parcel.
- B. A written commitment that is permitted or required by the Area Plan Commission or Board of Zoning Appeals is binding on the owner of the parcel even if the commitment is unrecorded. However, an unrecorded commitment is binding on a subsequent owner or other person acquiring an interest in the parcel only if that subsequent owner or other person has actual notice of the commitment.

12.14.5 Effective date of commitment

- A. A written commitment permitted or required by the Area Plan Commission in connection with a site development plan or a written commitment permitted or required by the Board of Zoning Appeals shall take effect upon the approval of the site development plan, special exception use, or zoning variance related to the commitment.
- B. A written commitment for a zoning map change or a Planned Unit Development shall take effect upon the later of the adoption of the rezoning or Planned Unit Development or the recording of the commitment. However, the rezoning ordinance will not become effective until the commitment has been recorded and all necessary legal requirements have been met.

12.14.6 Covenant running with the land

A written commitment that is permitted or required by the Area Plan Commission or Board of Zoning Appeals shall be considered a covenant running with the land and shall bind all subsequent owners to its terms and conditions and any subsequent modification thereto made pursuant to this instrument, statutes of the State of Indiana, or ordinance of White County.

12.14.7 Enforcement

Written Commitments permitted or required by the Area Plan Commission or Board of Zoning Appeals may be enforced jointly and severally by:

- A. The Area Plan Commission or Board of Zoning Appeals (whichever body permitted or required the commitment); and
- B. All persons with a legal interest in the property to be rezoned and all persons with real property abutting the property subject to a rezoning petition, all owners of real property adjacent to property or adjoining to property, are interested parties. The identity of such owners shall be determined from the records of the Office of the White County Auditor which list the current owners of record. For purposes of this paragraph, the cutoff date for such determinations shall be 12:00 noon on the date of filing for enforcement.

12.14.8 Recording

- A. Commitments shall be signed by the Executive Director, and shall be recorded in the office of the White County Recorder.

- B. The Area Plan Commission or Board of Zoning Appeals shall require the owner of the parcel given a written commitment to either record the commitment or authorize White County to record the commitment at the owner's expense.
- C. Commitments in connection with site development plans, special exception uses, or variances shall be recorded upon the granting of the approval. Commitments in connection with zoning map changes or Planned Unit Development shall be recorded as soon as possible after such approval by the appropriate legislative body of the rezoning or Planned Unit Development. Such development will not take effect until the commitment has been recorded.

12.14.9 Modification and termination

A written commitment that is permitted or required by the Area Plan Commission or Board of Zoning Appeals may be modified or terminated only by a decision of the Area Plan Commission or Board of Zoning Appeals (whichever body permitted or required the commitment) made at a public hearing after notice as provided by this Chapter. The request for modification or termination may be initiated by the property owner or by the body that permitted or required the commitment. The body that permitted or required the commitment may approve or disapprove modification or termination to the extent allowed by applicable law. However, pursuant to IC 36-7-4-1015 (4) as amended, a commitment may provide terms providing for its own expiration and/or terms for automatic termination.

12.14.10 Public notice

When the Area Plan Commission or Board of Zoning Appeals is going to consider modification or termination of an existing written commitment, notice of a public hearing shall be given in allowance to the requirements of this Chapter.

12.14.11 Validity of other land use restrictions

This Chapter does not affect the validity of any covenant, easement, equitable servitude, or other land use restriction created in accordance with law.

12.15 ZONING HEARING OFFICER AND ALTERNATE PROCEDURE

This section, established by the Area Plan Commission, provides for an Alternate Procedure by which a Development Standards Variance or Special Exception Use Permit may be approved

12.15.1 Authorization of the Area Plan Hearing Officer

There is hereby established by the Area Plan Commission, the position of Area Plan Hearing Officer, who shall have such powers and duties as are prescribed in the following section and by rule duly adopted by the Area Plan Commission.

12.15.2 Recommendation of the Area Plan Hearing Officer and Alternate

Recommendation for the assignment of the person to serve as the Area Plan Hearing Officer or Alternate, along with recommendation to remove such person, shall be by the Area Plan Commission. The Area Plan Commission may recommend approval, removal

or replacement of any Area Plan Hearing Officer or Alternate at any time, with or without cause.

12.15.3 Approval of the Area Plan Hearing Officer and Alternate Recommendations

Approval of all recommendations addressed in Section 12.16.2 of this Ordinance shall require approval by the White County Commissioners to become effective.

12.15.4 Powers and Duties of Zoning Hearing Officer

The Area Plan Hearing Officer shall have the same powers and duties as the Board of Zoning Appeals to approve or deny applications through the Alternate Procedure.

12.15.5 Alternate Procedure

The Area Plan Commission shall, by rule duly adopted;

- A. Establish the circumstances, if any, in which it would be appropriate for the Area Plan Hearing Officer to hear or transfer proceedings for applications submitted for Development Standards Variance or Special Exception Use Permits.
- B. Designate requirements for the conduct of proceedings before the Area Plan Hearing Officer including, but not limited to, the creation and filing of minutes and records, regulation of conflicts of interest and criteria for segregating applications between the Area Plan Hearing Officer and the Board of Zoning Appeals.

12.16 ADDRESSING, ROAD/STREET/ALLEY NAMING & BRIDGE DEDICATIONS

12.16.1 Purpose and Intent

The purpose of this Chapter is to establish uniform standards for house and building numbering in White County, Indiana and establish processes for naming or renaming roads/streets/alleys and dedicating bridges within White County. It is intended to provide continuity, avoid duplication and prevent general confusion regarding the location of developed parcels of land within the county.

12.16.2 Applicability

Unless otherwise stated, this Chapter shall apply to all roads and streets within White County with the exception of Interstate highways and portions of US Highways and State Roads outside of Municipality Corporation Limits. Addressing requirements apply to all structures as defined in Subsection 12.17.6 of this Chapter.

12.16.3 Definitions

For the purposes of this Chapter, the following definitions shall apply. Any other terminology utilized herein shall revert to common Area Plan definition procedures.

- A. Base Lines – Existing recognizable lines which divide the county into quadrants or sectors. The intersection of base lines establishes the starting point for the numbering system.

- B. Block Interval – The hundred number interval is the distance between grid lines, or the point where the next highest block number designation is used.
- C. Customer (Addressee) – A family, individual, residence, business or industry.
- D. Frontage Interval – The distance in foot frontage along a street, highway or county road which is used to assign consecutive property numbers, beginning from the nearest grid or base line. The address system used by White County assumes a frontage interval of five and twenty-eight hundredths (5.28) feet.
- E. Grid Lines – Imaginary lines or actual county roads which are located a specific distance from and perpendicular or parallel to base lines. These lines indicate the point where block numbers change from one hundred to the next higher hundred. Grid lines are used to standardize the numbering of parallel blocks at the same distance from the base lines.
- F. Primary Address Number (City-type Address) – The numeric or alphanumeric component of a city-type address which precedes the street name.
- G. Structure – A residential home, apartment building, business or commercial building, industrial or manufacturing building, town home, condominium, wind turbine, communications tower, meteorological tower, publicly owned building, or other similar improvement which fronts onto a public or private street or road or is accessed via an easement.

12.16.4 Ordinance Repeal

White County Ordinance #COMM-91-12-16, Road Numbering and Naming in White County and Ordinance Amendment #05-10-03-02 Road Numbering and Naming in White County are repealed by this Ordinance.

12.16.5 Bridge Dedications

Any bridge located within White County may be dedicated by:

- A. Submitting, in writing, the proposed name of dedication to the Staff for review. The Staff shall approve or deny the request. The Staff shall deny the request only under the condition that the name can be confused with a street, community or other dedicated location.

Upon approval, the request will be forwarded to the appropriate legislative body for final approval or denial.

12.16.6 Addressing

This Section provides the street numbering system in order to provide an exact geographic location for all structures in the County.

- A. Assignment Authority
 - 1. The Staff shall serve as the coordinating body in White County with the responsibility for assigning street addresses within the jurisdiction of the White County Area Plan Commission. The Staff shall coordinate its addressing efforts with the White County E 9-1-1 Communications Director, local Postmasters and large mailers into the county such as utilities and government.

2. Staff shall send out address assignments or address changes on the first business day of each month to all parties listed above.

B. The Grid Coordinate System

For White County, the naming of the road system and the issuance of structure addresses is based on the Lyman/Purdue Street Numbering System. The system is better known as the Grid Coordinate System. The system utilizes two base lines which run at approximate right angles to each other to divide the county into quadrants. Most of the county roads are numbered based on their distance from the north-south or east-west base lines. The center point of the county is at the intersection of Main Street and Logan Street in Reynolds. The north-south and the east-west section lines from that point are the established base lines from which all county addresses originate (excluding municipality addresses which shall be established from a center point within the municipality).

C. Measurements

All address measurements will be taken from the middle of an intersection.

D. Assignment of Official, Permanent Property Addresses

1. Structures located in White County shall be assigned a permanent city-type street address. Structures located on the south side of an east-west street/road and those located on the west side of a north-south street/road shall have an even numbered property address. Structures located on the north side of an east-west street/road and those located on the east side of a north-south street/road shall have an odd number. Municipalities in which addressing was originally set up in reverse, shall have addresses assigned in the manner in which they were originally set up.
2. When possible, a structure shall be addressed to the street/road in which the front entrance faces.

E. Determining a Property Address

1. Rural Addresses

An official street address shall contain no more than five digits with the first digit, or the first two digits if the structure is located ten (10) or more miles from the baseline, indicating the miles from the relative base line. The last three digits indicate the additional distance in thousandths of a mile to the structure or entry to the structure from the relative baseline. A rural address of less than four digits indicates the structure or entrance to the structure is less than one mile from the relative baseline. In the case of most rural addresses, the address should be assigned from where the entry to the structure meets the road as this is how the Emergency 9-1-1 service will locate the property in the most expedient manner, which is the main focus of the address assignment.

2. Municipality Addresses

An official street address is established by the system set up within each municipality with the first digit of a three-digit address and the first two digits in a four digit address indicating the number of blocks from the relative baseline.

3. Diagonal Street Addresses

Addresses on diagonal streets shall be assigned in the general direction in which the street runs.

4. Loops & Circles

Loop addresses shall be assigned as any other street address with the exception that the numbers will run consecutively from one end of the loop to the other with no regard to the rounded part of the loop that runs in an opposite direction. If the outside numbering of the loop is odd numbers, the inside of the loop will be even numbers and vice versa. Loop addressing will not follow the general north/east odd numbers and south/west even numbers. A Circle begins and ends on the same street with consecutive odd numbering on the outside of the circle and consecutive even numbering on the inside as described in the American Planning Association Report No. 332 Planning Advisory Service "Street-Naming and Property-Numbering Systems" by Margaret A. Corwin.

F. Placement and Size of Address Numbers

1. Once a property address has been assigned to a specific structure, it shall be the responsibility of the property owner or resident to provide the address number on the structure and the mailbox or mailbox post in rural areas.
2. Numerical components are to be placed on structures in a location which faces or is visible from the street upon which it is addressed except where the entrance does not front a street or road, then the structure shall be addressed in reference to its location as to a street or road or by a sign visible from the road.
3. Numerical components shall be a minimum of one (1) inch in height on a mailbox or mailbox post and minimum of two (2) inches in height on a structure or sign.
4. The numerical components placed upon a structure should be placed near a main entry door or on a cornice, porch, etc., located above the main entry door. The numbers should be located at least five (5) feet above the threshold near the entrance door. Numerical components on the structure shall contrast in color with the background of the structure upon which they are posted.
5. Numerical components placed on the mailbox or mailbox post must be located so as to face the postal carrier route. Numbers and lettering may be placed on both sides of the mailbox or mailbox post if so desired by the property owner or resident.

Street address numbers and lettering must be placed in a visible location on all structures by January 1, 1992 or, in cases of structures built after January 1, 1992, prior to issuance of an occupancy permit.

12.16.7 Street/Road/Alley Name Assignments or Changes

For purposes of this Section, when the term "street" is used, it shall include road and alley.

- A. Original Street Name Assignments for Public Streets to lie within a Subdivision.

1. All street names to lie within a platted, recorded subdivision shall be assigned as required by the White County Indiana Subdivision Control Ordinance.
- B. Street Name Assignments for Public Streets outside a Recorded Subdivision.
1. Naming of new streets or existing streets without names
 - a. Petitioner shall submit in writing a name or list of names and their location as shown on the White County GIS mapping system to the Staff. The maps shall show the full extent of the proposed or existing street area. Multiple maps should be submitted if required.
 - b. There shall be no re-use of former or discontinued street names. With the exception of street extensions, there shall be no duplication of street names by sound or spelling. No street name shall duplicate or too closely resemble, phonetically or in spelling, the name of any existing street anywhere else within the jurisdiction of the White County Area Plan Commission. Differentiation shall not be by the addition of suffixes such as road, street, land, trail, way or any other such suffix.
 - c. Staff shall check proposed names and certify the names submitted as acceptable or not acceptable according to the rules of this Chapter. The Staff shall check for duplicates, previously rejected names, names reserved for subdivisions not yet completed and phonemes.
 - d. Staff shall submit the proposed name to the United States Postal Service, Emergency 9-1-1 and the Monticello Fire Department for approval. Each Agency shall provide an opinion of acceptability to the Staff which shall be provided to the determining authority.
 - e. In the event that the proposed street name is acceptable to all parties, the Staff shall prepare a verified petition and submit such petition to the appropriate legislative body for consideration at the body's public meeting for adoption. If the street being named is both in a municipality and outside the municipality, the petition will be submitted to the legislative body wherein the majority of the street lies.
- C. Renaming of Streets
1. A petitioner desiring to have a street renamed shall provide a written justification for the request (maximum 300 words) including the reason or reasons for the request.
 2. The petitioner shall submit in writing a proposed name or list of names including cross reference to the street's current name.
 3. The renaming of streets shall be subject to the same standards as the naming of new streets. In addition, the petitioner shall provide the Staff with the following:
 - a. A map showing the entire street in question, including the names and complete address of each property owner abutting the street petitioned to be changed. Vacant lots shall be identified as such on the map.

- b. A second map shall show all alleys, and streets within one quarter (1/4) mile of any portion of the street petitioned to be changed.
- c. A petition calling out the existing street name and the signatures of all parties as identified above, or an affidavit authorizing an agent to act on behalf of said parties, signifying their agreement with the proposed name change.
- d. Any additional information reasonably required by the Staff.
- e. Any applicable fee as prescribed by the Official Fee Schedule.

D. Private Streets

Private streets may be named or renamed by the Staff. Private streets shall be subject to the same street name standards as spelled out in Section 12.17.7 B 1b and Section 12.17.7 B 1c of this Ordinance.

CHAPTER 13 ENFORCEMENT

13.0 GENERAL PROVISIONS

13.0.1 Authority

The Executive Director is hereby designated to enforce the terms and provisions of the Zoning and Subdivision Control Ordinances, herein after referred to as “the Ordinances” in this Chapter, in accordance with the provisions of this Chapter. For purposes of this Chapter, the term “Executive Director” shall also refer to his/her authorized designee.

13.0.2 County

The County, by its authorized official, may, by suit in the Circuit or Superior Court(s) of White County, enjoin violations of the Ordinances.

13.0.3 Area Plan Commission

The Area Plan Commission by and through its duly authorized agent may, by suit in the Circuit or Superior Court(s) of White County seek to enjoin violations of the Ordinances.

13.0.4 Persons Liable

Any structure, land, building, or premises used in violation of this Ordinance shall constitute a civil zoning violation. The owner, possessor, tenant, occupant or contract vendee of any structure, land, building, or part thereof who keeps, maintains, creates, causes, assists, directs, or participates in any use or situation thereon that is contrary to the requirements of the Ordinances shall be responsible and liable for the violation and all penalties, fines or other damages connected with or caused by the violation.

13.0.5 Right of Entry

The Executive Director may enter upon any premises at any reasonable time to make inspections of all buildings, structures, and premises located within the jurisdiction of the Ordinances to determine their compliance with the Ordinances. Upon entry, the Executive Director shall furnish sufficient identification and information advising the owner, tenant, or occupant that the Executive Director is a representative of White County and the reason for the inspection. If the Executive Director is denied access to or entry upon the premises, the Area Plan Commission by and through its duly authorized agent may apply to any court of competent jurisdiction for permission for the Executive Director to access and enter the premises.

13.0.6 Stop Work Order

The Executive Director and The Area Plan Commission, by and through its duly authorized agent, are empowered to issue a stop work order and/or revoke an Improvement Location Permit requiring the suspension of land improvement of any kind, if, and in the event that, any of the following circumstances exist:

- A. A site is being improved without an Improvement Location Permit or any other permit required by the Ordinances; and/or
- B. A site is being improved in violation of:

1. The terms, conditions, or provisions of the Ordinances;
2. The terms, provisions, conditions, or commitments of a variance;
3. The terms, provisions, conditions, or commitments of a special exception use permit;
4. The terms, provisions, or commitments of a Planned Unit Development plan;
5. A commitment made in connection with a petition for a zone map amendment; and/or
6. Any other development approval granted under the Ordinances.

The stop work order shall be posted in a conspicuous place on the property on which the violation is located or occurring, or personally delivered to the owner, occupant, tenant, or person in charge of the property.

The Area Plan Commission, by and through its duly authorized agent, may bring a cause of action in a court of competent jurisdiction in White County, Indiana to enforce the provisions of a stop work order.

Remediation

The Executive Director shall determine whether a violation has been properly remediated. If the Executive Director determines it appropriate or necessary, he/she shall determine a dead line for remediation completion. If the Executive Director determines it is desirable for achieving compliance to the Ordinances, he/she may provide remediation alternative(s) to a violator.

13.1 CIVIL ZONING VIOLATIONS

13.1.1 Enforcement Procedures

Nothing in this Chapter precludes the Executive Director from making contact in verbal, written or electronic format, with any person in violation or potentially in violation of the Ordinances prior to the issuance of a warning ticket or citation.

13.1.2 Enforcement Without Prior Notice

Prior enforcement notice is not required where a violation is determined by the Executive Director to be a threat to public health or safety or where elsewhere provided in the Ordinances, the Area Plan Commission, by or through its duly authorized agent, may seek abatement or cessation of the violation by invoking any penalties or remedies authorized by the Ordinances or by law.

13.1.3 Warning Ticket

- A. Any person who violates the Ordinances shall be deemed to have committed a civil zoning violation. Upon a finding by the Executive Director that a person has committed a civil zoning violation, the Executive Director shall issue a written warning ticket to, but in no way limited to, the legal owner, tenant, contract vendee, or any person or entity with a possessory interest in the property upon which the violation occurs.
- B. The warning ticket shall be served by personal service, by certified mail, or by placement in a conspicuous place on the property where the violation occurs and shall serve as notice of the civil zoning violation. The warning ticket shall be in the form prescribed by the Executive Director

- C. Unless otherwise provided in the warning ticket, the violator shall have thirty (30) days to abate the violation.
- D. A person who receives a warning ticket may:
 - 1. Correct the violation;
 - 2. File a petition for a variance, special exception use, or rezone;
 - 3. Negotiate an acceptable compliance plan with the Executive Director;
 - 4. Utilize other means provided by the Ordinances to correct the violation.
- E. The Executive Director's finding of a violation of the Ordinances may be appealed to the Area Board of Zoning Appeals by the filing of a proper application which meets the requirements of Section 12.6.4 of the Zoning Ordinance with the Area Plan Office within thirty (30) days from the date the warning ticket was issued. Upon receipt of a completed application and all other required information and documents, the Staff will schedule the appeal for the next applicable meeting of the Area Board of Zoning Appeals. The Staff will provide the Board with all of the necessary documentation creating the record of appeal.
- F. If the Area Board of Zoning Appeals upholds the Executive Director's finding of a violation, the violator may file for Judicial Review as provided for in the 1600 Series of IC 36-7-4 as amended from time to time. A person must have standing to submit a petition for judicial review of a zoning decision of the Area Board of Zoning Appeals to the appropriate court. The petition shall be presented to the court not later than thirty (30) days after the date of the zoning decision that is the subject of the petition for judicial review. A person who fails to timely object to a zoning decision or timely petition for review a zoning decision within the thirty (30) day period prescribed in this section waives the right to judicial review under this subsection. For purposes of this subsection, the following is applied:
 - 1. "Standing" is determined as provided for in IC 36-7-4-1603 of the 1600 Series as amended from time to time.
 - 2. "Zoning Decision" is defined in IC 36-7-4-1016 of the 1000 Series as amended from time to time.A person may file a petition for judicial review under this section only after exhausting all administrative remedies available within the Area Board of Zoning Appeals.
- G. The Executive Director's finding of a violation of the Ordinances may only be appealed one time to the Area Board of Zoning Appeals. Such appeal shall be made before a citation is issued for the violation.

13.1.4 Citations

- A. In the event that a person fails to act in the time stipulated upon the warning ticket issued under section 13.1.2, the Executive Director may issue a citation for the continuing civil zoning violation and assess a fine according to the Fine Schedule.
- B. For the purposes of this Chapter, the term "Fine Schedule" shall mean the Fine Schedule for civil zoning violations, officially adopted by the White County Board of

Commissioners. The citation shall be in the form prescribed by the Executive Director.

- C. Once a citation is issued, each day a violation remains uncorrected shall be considered a distinct and separate civil zoning violation, and may be subject to a daily fine in an amount prescribed by the Fine Schedule and indicated in the respective citation or fine assessment notice.
- D. All fines shall be paid to the Area Plan Office within thirty (30) days from the date the citation was issued or within a time frame and schedule as agreed to by the Executive Director. The Staff shall render to the person making the payment a receipt stating the amount and purpose for which the fine has been paid and a duplicate of which shall be made a part of the records of the Area Plan Office.
- E. A person who receives a citation may elect to abate the violation and pay the assessed fine, negotiate an acceptable settlement and compliance plan with the Executive Director or appeal the amount of the fine in accordance with Section 13.1.5 of this Chapter within thirty (30) days from the date the citation was issued. Any additional monetary fine, as prescribed by the Fine Schedule, shall be stayed upon application for appeal. Upon receipt of an application to appeal the fine, the person will be scheduled to be heard by The Area Board of Zoning Appeals at the next applicable meeting. The person will be notified by mail of the time, date and location of the scheduled meeting. The Area Plan Staff will provide the Board with all of the necessary documentation creating the record of the appeal.
- F. The Area Board of Zoning Appeals' decision regarding the amount of the fine assessed may be appealed by filing for Judicial Review as provided for in the 1600 Series of IC 36-7-4 as amended from time to time. A person must have standing to submit a petition for judicial review of a zoning decision of the Area Board of Zoning Appeals to the appropriate court. The petition shall be presented to the court not later than thirty (30) days after the date of the zoning decision that is the subject of the petition for judicial review. A person who fails to timely object to a zoning decision or timely petition for review a zoning decision within the thirty (30) day period prescribed in this section waives the right to Judicial Review under this subsection. For purposes of this subsection, the following is applied:
 - 1. "Standing" is determined as provided for in IC 36-7-4-1603 of the 1600 Series as amended from time to time.
 - 2. "Zoning Decision" is defined in IC 36-7-4-1016 of the 1000 Series as amended from time to time.A person may file a petition for Judicial Review under this section only after exhausting all administrative remedies available within the Area Board of Zoning Appeals.
- G. If a person fails to pay the assessed fine as required, the Area Plan Commission or Executive Director on behalf of the Area Plan Commission, may authorize the Area Plan Commission Attorney to file a civil lawsuit or to pursue any other remedy available under the law.
- H. A person adjudged to have committed a zoning violation is liable to the Area Plan Commission for court costs and attorney fees incurred in connection with enforcing the Ordinances and collecting assessed fines.

- I. Seeking a civil penalty as authorized by this Chapter shall not preclude the Area Plan Commission, or Executive Director, on behalf of the Area Plan Commission, from seeking alternative relief from the court in the same action, or from seeking injunctive relief or other remedy in a separate action for the enforcement of the Ordinances.
- J. A change of venue from White County shall not be granted in such a case, as provided in Indiana Code 36-7-4-1014, as amended from time to time.

13.1.5 Appeals

A. General Provisions

1. A person who receives a warning ticket, a citation or a fine assessment may choose to file an appeal to the Area Board of Zoning Appeals in accordance with the procedures set out in this section. In addition to the requirements of this Section, all appeals must be filed in compliance with Section 12.6.4 of the Zoning Ordinance.
2. An appeal of the Executive Director's issuance of a warning ticket and determination that a violation exists, may only be appealed one time to the Area Board of Zoning Appeals. Such appeal shall be made before a citation is issued for the violation.
3. An appeal of a fine and late fees issued by the Executive Director may only be appealed one time to the Area Board of Zoning Appeals. Such appeal shall be made within thirty (30) days from the date of the initial fine issuance. Any additional monetary fine, as prescribed by the Fine Schedule, shall be stayed upon the filing of an appeal.
4. A person who files the appeal within the time period set forth above shall pursue the petition in an expeditious fashion.
5. Upon receipt of a completed application and all other required information, documents and filing fees, the Area Plan Staff will schedule the appeal for the next applicable meeting of the Area Board of Zoning Appeals.
6. The Area Plan Office will provide the Board with all of the necessary documentation creating the record of the appeal.
7. Any person aggrieved by a decision of the Board may file for judicial review as provided for in the 1600 Series of IC 36-7-4 as amended from time to time. A person must have standing to submit a petition for judicial review of a zoning decision of the Area Board of Zoning Appeals to the appropriate court. The petition shall be presented to the court not later than thirty (30) days after the date of the zoning decision that is the subject of the petition for judicial review. A person who fails to timely object to a zoning decision or timely petition for review a zoning decision within the thirty (30) day period prescribed in this section waives the right to judicial review under this subsection. For purposes of this subsection, the following is applied:
 - a. "Standing" is determined as provided for in IC 36-7-4-1603 of the 1600 Series as amended from time to time.
 - b. "Zoning Decision" is defined in IC 36-7-4-1016 of the 1000 Series as amended from time to time.

8. A person may file a petition for Judicial Review under this section only after exhausting all administrative remedies available within the Area Board of Zoning Appeals.
- B. The violator may appeal the finding of a violation by the Executive Director.
1. If the Board denies the Executive Director's finding of a violation, all enforcement action(s) related to the appeal shall be dismissed.
 2. If the Board upholds the Executive Director's finding of a violation, the enforcement process moves forward.
 3. The violator may file for a Judicial Review of the Area Board of Zoning Appeals' decision as provided for in this Chapter. The filing must be filed within thirty (30) days of the Area Board of Zoning Appeals' decision.
 4. The violator may appeal the fine assessed by the Executive Director;
 5. The Board may determine the fines assessment is appropriate and leave stand;
 6. The Board may reduce the fine assessment if it sees fit;
 7. The Board may increase the fine assessment if it sees fit.
- C. Upon receipt of a completed application and all other required information and documents, the Staff will schedule the appeal for the next applicable meeting of the Area Board of Zoning Appeals.
- D. Staff will provide the Board with all of the necessary documentation creating the record of the appeal.
- E. If the Board upholds the determination of a violation(s) of the Ordinances which led to issuance of the warning ticket or citation, and the civil zoning violation continues at the real estate, then the warning ticket or citation will move forward as required in 13.1.1 or 13.1.2, whichever applies. The applicant can conform to the Ordinances, correct the violation and pay the fine(s), file for Judicial Review or request a trial on the citation for determination by a court of competent jurisdiction in White County, Indiana.

13.1.6 Trial

- A. Upon receipt by the Staff of the notice of intention to stand trial, a lawsuit will be commenced by the Area Plan Commission Attorney in a White County, Indiana court. The matter shall be scheduled for trial, and a Summons and Order to Appear shall be served upon the Defendant.
- B. If a person who receives a citation fails to pay the assessed fine within the time limit as established by the citation and/or fails to correct or abate the citation, the Area Plan Commission or Executive Director may direct the Area Plan Commission Attorney to file a civil lawsuit as prescribed by applicable laws and ordinances, and seek penalties as prescribed in this Chapter or by law.
- C. A person adjudged to have committed a zoning violation is liable for the court costs and fees. No costs shall be assessed against the enforcement agency in any such action.

- D. In proceedings before the court for a zoning violation, the Indiana Rules of Trial Procedure shall govern. The designated enforcement entity has the burden of proving the civil zoning violation by a preponderance of the evidence.
- E. Seeking a civil penalty as authorized by this section does not preclude the County or Area Plan Commission from seeking alternative relief from the court in the same action, or from seeking injunctive relief or other remedy in a separate action for the enforcement of the Ordinances.

CHAPTER 14 DEFINITIONS

14.0 PURPOSE AND INTENT

For the purpose of this Ordinance, certain terms or words used herein shall be interpreted according to the rules and definitions of this Section, except when the context clearly indicates otherwise.

Whenever any words and phrases used herein are not defined but are defined in the State laws regulating the creation and function of various planning activities, any such definition therein shall be deemed to apply to such words and phrases used herein except when the context otherwise requires. All other words or phrases not herein defined shall be defined from the following resources in the order as listed below. The first resource to provide an appropriate definition for a word or phrase shall have supremacy over subsequent definitions.

Resource order for definitions:

- First, definitions as established and amended within the 2008 White County Zoning Ordinance definition section;
- Second, definitions as established and amended within the 1995 White County Zoning Ordinance definition section;
- Third, definitions as established and amended within the 1970-72 White County Zoning Ordinance definition section;
- Fourth, definitions found in any recent edition of Webster's dictionary, and;
- Finally, definitions for any words, terms or phrases not found in any resource identified above, the Staff shall use any resource available to them and shall determine the definition which will be utilized for zoning regulation purposes.

14.1 RULES

14.1.1 Word tense

Words used in the present tense include the future tense; words used in the future tense include the present tense; words used in the singular include the plural; and words used in the plural include words used in the singular.

14.1.2 Persons and other responsible parties

The word "person" includes an individual, firm, association, organization, partnership, trust, company, corporation, or any legal entity.

14.1.3 Masculine vs. feminine

Words used in the masculine include the feminine; words used in the feminine include the masculine.

14.1.4 Distinguishing between what is mandatory, permissive and preferred

The word “shall” is mandatory; the word “may” is permissive, and the word “should” is a preferred requirement.

14.1.5 Using and occupying a space

The words “used” or “occupied” include the words “intended, designed, or arranged to be used or occupied.”

14.1.6 Lot, plot or parcel

The word “lot” includes the words plot or parcel.

14.1.7 Time

The time within which any act required by this Ordinance is to be performed shall be computed by excluding the first day and including the last day, unless the last day is a Saturday or Sunday or a holiday declared by the United States Congress or the Indiana General Assembly, in which event it shall also be excluded. The word “day” shall mean a calendar day, unless otherwise indicated.

14.1.8 Captions, illustrations, and tables

In case of any difference of meaning or implication between the text of this ordinance and any caption, illustration or table, the text shall control and no caption, illustration or table shall be construed to limit the scope or intent of the text of this ordinance.

14.2 WORDS & PHRASES DEFINED

ABANDONMENT – The relinquishment of property or a cessation of the use of the property by the owner with the intention neither of transferring rights to the property to another owner nor resuming the use of the property.

ABUTTING – To physically touch or border upon; or to share a common property line.

ACCESS – A way or means of approach to provide physical entry to a property.

ACCESS ROAD – A street designed to provide vehicular access to abutting property and to discourage through traffic.

ACCESSORY STRUCTURE - A structure that is subordinate to a principal structure, and which does not change or alter the character of the premises. No mobile home, manufactured home, vehicle, tractor, semitrailer, hauling trailer, construction trailer, railroad boxcar, storage pod, shipping container or any other similar type unit may be used as an accessory structure in any residential or commercial district.

ACCESSORY USE – A use subordinate in area, extent and purpose to a principal use, that contributes to the comfort, convenience or necessity of a principal use, and that is located on the same or near-by (within 360 feet) lot; “near-by” meaning the closest points of each lot perimeter are not separated by more than three hundred sixty (360) feet.

ACCESSORY PORT - A temporary tubular, steel or wood framed structure not completely enclosed by walls or doors and which is open on at least two sides. An accessory port is similar to a car port but is not used for automobile parking.

ACRE – A measure of land area containing forty-three thousand five hundred and sixty (43,560) square feet.

ADDITION – Any construction that increases the size of a building or structure in terms of site coverage, height, length, width, or gross floor area.

ADMINISTRATOR - The official appointed and/or delegated the responsibility for the administration of these regulations of this Ordinance.

ADULT ENTERTAINMENT BUSINESS - Any adult bookstore, adult hotel or motel, adult motion picture arcade, adult motion picture theater, cabaret, sexual encounter center, or any other business or establishment that offers its patrons services or entertainment characterized by an emphasis on matter depicting, describing, or relating to specified sexual activities or specified anatomical areas, but not including those uses or activities, the regulation of which is preempted by state law. Access is restricted by age.

AGGREGATED PROJECTS – Projects which are developed or operated in a coordinated fashion, but which have multiple entities separately owning one or more of the individual WECS within the larger project. For the purpose of administering and enforcing this Chapter, all associated infrastructure, such as power lines or transformers or other components that service the WECS facility, while being owned by a separate entity or entities are included as part of an aggregated project.

AGRI-ANIMAL PRODUCTION – An operation or facility that uses small animal by-products or components for production of medical devices, food supplements or additives or other scientific or commercial purpose. Agri-Animal Production does not include aerobic or anaerobic digesters whether used as a principle use or an accessory use.

AGRI BIO PRODUCTION – An operation or facility that uses animal by-products, members, materials or component parts for production of medical devices, food supplements, food additives or other scientific or commercial purpose.

AGRICULTURAL INDUSTRY – Facilities where materials, used for the production of fuel alcohol and fertilizers are raised, grown, produced or processed for refinement. Sources may be plants grown especially for that purpose or waste products from livestock, harvesting, milling, or from agricultural production or processing.

AGRICULTURAL PRODUCE BUSINESS, PERMANENT - A permanently sited retail business engaged in the display and sale of agricultural produce and products.

AGRICULTURAL PRODUCE BUSINESS, SEASONAL - A temporary retail business in a permanent structure, engaged in the display and sale of agricultural produce and products, which are primarily grown in the season in which they are being sold.

AGRICULTURAL PRODUCE PRODUCTS – Nutritional food items or plant/seed items utilized in a cooking process such as fresh fruits, vegetables, meats and eggs grown on-site or locally, homemade food products, products made at facilities on-site, food products created by a limited or simplified process such as nuts, jams, jellies, popcorns, ciders, honey, syrups, flours, spices, etc., locally harvested plant and plant components. Complex food products such as mass-marketed products normally found in a grocery or convenience store are not included.

AGRICULTURAL PRODUCE SALES, PORTABLE – A portable structure or vehicle such as a truck, wagon, tent, or table, temporarily located at or adjacent to a site not owned by the owner of the portable structure or vehicle from which produce is sold, sometimes in conjunction with a Farmer's Market.

AGRICULTURAL RESEARCH FIRM – A business that conducts research on agricultural or horticultural produce including, but not limited to, crops, vegetables, fruits, livestock, fish and poultry. Research work may be conducted in the field, greenhouse, and laboratory or enclosed housing facility.

AGRICULTURAL ROADSIDE STAND - A removable structure used or intended to be used solely by the owner or the tenant of a property on which it is located for the sale of seasonable agricultural products produced on the premises and to be removed and stored back of the building line on the property at the conclusion of the seasonal sales.

AGRICULTURE SERVICE & SUPPORT – A business which provides a direct service or product in support of farming activities or which manufactures or produces a product to be utilized by the farming industry and which has not been specifically delineated elsewhere.

AGRICULTURE – The use of land for agricultural purposes, including necessary buildings and structures which shall be used for such uses, but not limited to, farming, seed production and processing, dairying, pasturage, horticulture, floriculture, an animal and poultry husbandry and the necessary accessory uses for packing, treating or storing produce; provided, however, that the operation of any such accessory uses shall be secondary to that of the normal agriculture activities.

AIRPORT – Any area of land or water designated, set aside, used, or intended for use, for the landing and take-off of aircraft, and any appurtenant areas designated, set aside, used, or intended for use, for airport buildings or other airport facilities, rights-of-way, or approach zones, together with all airport buildings and facilities located thereon.

AISLE – The traveled way by which cars enter and depart parking spaces.

ALLEY – An unnamed public or private right-of-way that is primarily designed to serve as secondary access to the rear or side of those properties whose principal frontage is on some other street.

ALTERATION – Any change, addition, or modification in construction, other than cosmetic or decorative, or any change in the structural members of buildings such as bearing walls, columns, beams, or girders.

AMENITIES - Aesthetic or other characteristics of a development that increase its desirability to a community or its marketability to the public. Amenities may differ from development to development but may include such things as a unified building design, recreational facilities (e.g., a swimming pool or tennis courts), security systems, views, landscaping and tree preservation, or attractive site design.

AMPHITHEATER - A building or large open outdoor area or structure specifically designed and used as a place of assembly for band concerts, theatrical performances, games or other methods of entertainment, and partly or completely surrounded by tiers of seats for spectators.

AMUSEMENT PARK - An area of land which operates eight or more mechanical rides, games, concessions, various attractions, band concerts, theatrical performances or other methods of entertainment. These facilities are stationary and built for long-lasting operations and may require payment of a fee for entrance or entertainment activities. Excluded are municipally owned public parks.

AMUSEMENT PARK OFFICES – Offices used to conduct the daily activities of an amusement park.

ANIMAL - Any live or dead dog, cat, non-human primate, guinea pig, hamster, rabbit, or any other warm-blooded or cold-blooded animal, which is being used, or is intended for use for research, teaching, testing, experimentation, exhibition purposes, sale or as a pet. This term excludes: birds, rats of the genus *Rattus* and mice of the genus *Mus* bred for use in research, and horses and other farm animals, such as, but not limited to livestock or poultry, used or intended for use as food or fiber, or livestock or poultry used or intended for use for improving animal nutrition, breeding, management, or production efficiency, or for improving the quality of food or fiber. With respect to a dog, the term means all dogs including those used for hunting, security, or breeding purposes.

ANIMAL, DOMESTIC - An animal that is tame or domesticated and which is not normally found in the wild state and which is not classified or considered wildlife, livestock, or exotic animal. Hybrids of animals normally found in the wild state are not included within the meaning of domestic animal.

ANIMAL, EXOTIC - Means any animal that is not normally domesticated in the United States or is wild by nature. Exotic animals include but are not limited to, any of the following orders and families, whether bred in the wild or captivity, and also any of their hybrids with domestic species. The animals listed in parentheses are intended to act as examples and are not to be construed as an exhaustive list or limit the generality of each group of animals, unless otherwise specified: Non - human primates and prosimians (monkeys, chimpanzees, baboons); Felidae (lions, tigers, bobcats, lynx, cougars, leopards, jaguars, not domesticated cats); Canidae (wolves, coyotes, foxes, jackals, not domesticated dogs); Ursidae (all bears); Reptilia (all venomous snakes, all constricting snakes); Crocodilia (alligators, crocodiles); Proboscidae (elephants); Hyänenidae (hyenas); Artiodatyla (hippotamuses, giraffes, camels, not cattle or swine or sheep or goats); Procyonidae (raccoons, coatis); Marsupialia (kangaroos, opossums); Perissodactylea (rhinoceroses, tapirs, not horses or donkeys or mules); Edentara (anteaters, sloths, armadillos); Viverridae (mongooses, civets, and genets).

ANIMAL FOOD MANUFACTURING – A facility or operation which utilizes plant or animal materials to process and prepare in a manner intended for consumption by non-human animals.

ANIMAL SANCTUARY – A facility where animals are brought and provided a safe haven, normally for the rest of their lives. The animals are brought to the facility to live and be protected. These facilities do not seek to place animals with individuals or groups.

ANIMAL SHELTER – An establishment which provides temporary housing and care for dogs, cats and other small pets while offering such animals for adoption.

ANTENNA - Any system of wires, poles, rods, reflecting discs, or similar devices used for the transmission or reception of electromagnetic waves external to or attached to the exterior of any building or, for the purpose of wireless communication service, any communications equipment that transmits or receives electromagnetic radio signals used in the provision of wireless communications service.

ANTENNA, AMATEUR RADIO - An apparatus used to transmit radio signals as a pastime rather than as a profession.

ANTENNA, RADIO – An apparatus used to transmit and/or receive radio signals.

ANTENNA, TELEVISION – An apparatus used to transmit and/or receive television and/or satellite signals.

APARTMENT – A unit of one or more rooms within a residence, building or business which is dedicated to serve as a dwelling unit and which provides accommodations for sleeping, living, lavatory and kitchen facilities. The unit is designed for occupancy by only one (1) family.

APARTMENT, ACCESSORY - A subordinate dwelling unit contained on the same lot as the primary dwelling unit or a business, but located separate from the principal structure. The dwelling unit must be incorporated within an accessory structure and not utilize more than fifty (50) percent of the total square footage of floor space of the accessory structure. If the accessory structure has more than one floor, the total square footage is calculated by totaling up the square footage of each floor.

APARTMENT, BUILDING – A building which provides three (3) or more dwelling units.

APARTMENT, MICRO-UNIT – A studio or efficiency apartment defined primarily by its size and occupancy. Micro-units consist of a kitchen or built-in kitchenette, bathroom and with combined living room/sleeping quarters. The units are limited to no more than 325 square feet and are restricted in occupancy to a maximum of two people. Micro-unit apartments may only be located within a municipality, require approval of the local legislative body and are restricted to B-1 & B-4 zoning districts. These units are exempt from the dwelling unit size requirements of Appendix B: Bulk Use Standards.

APIARY – A place where a colony or colonies of domestic honey bees are kept such as, but not limited to, a beehive(s) or bee house(s) (a small, wall-less, roofed structure), where domestic honey bees are raised to produce honey or to promote plant life pollination.

APPLICANT - The owner of land, engineer or contractor who makes application to the White County Area Plan Commission or Board of Zoning Appeals for action by said Commission or Board, affecting that land.

ARCADE - A building or part of a building containing four or more game machines, instruments or apparatuses operated by coin, slug or similar medium, but not including automatic machines for vending food, soft drinks or tobacco, and outside service vending machines.

AREA, GROSS – All areas (whether covered by land or water or rights-of-way) contained within the perimeter property boundaries of a proposed project.

AREA, NET – The land area of a parcel excluding those areas that contain structures, parking or other impervious surfaces, and non-buildable natural features such as wetlands, woodlands, natural habitats, and the like as specifically described.

AREA PLAN COMMISSION – A County Plan Commission serving multiple local government jurisdictions established as defined under the IC 36-7-4-200, etc. al, as amended. The White County Plan Commission is an Area Plan Commission.

ASPHALT PLANT (MANUFACTURING) – An operation for the manufacture of asphalt, macadam and other forms of coated road stone, sometimes collectively known as blacktop.

ASSISTED LIVING FACILITY - A multiple family structure, controlled either by a public body, institutional body, or nonprofit corporation, a majority of whose occupants shall be 65 years of age or over, or a multiple family structure where each unit is occupied by at least one (1) person who is 55 years of age or over and is retired, and where the rental arrangement includes primarily non-medical services to deal with the activities and instrumental activities of daily living.

AUCTION – A sale of goods or services where prices are established through a process of competitive and open bidding.

AUCTION, SALE – An auction which takes place as a sporadic event to dispose of either personal or real property or as a fund-raising event for a non-profit organization.

AUCTION ARENA OR SALES BARN FOR LIVESTOCK – A barn or other accessory building or area on agricultural land designed, constructed, and used to house livestock and related uses for the purpose of selling livestock to buyers.

AUCTION ARENA OR SALES YARD (EXCLUDING LIVESTOCK) - A building, area, or areas within a building used for the public sale of goods, wares, merchandise, or equipment to the highest bidder through open public bidding.

AUTOMATED TELLER MACHINE (ATM) - A mechanized device that performs financial functions, whether outside or in an access-controlled facility.

AUTOMOBILE CONVENIENCE MART – A place where gasoline, motor oil, lubricants, or other minor accessories are retailed directly to the public on the premises in combination with the retailing of items typically found in a convenience market or supermarket.

AUTOMOBILE PARTS/SUPPLY RETAIL ESTABLISHMENT – A store that displays and sells new or used automobile parts, tires, and accessories. May also include minor installation.

AUTOMOBILE RENTAL/LEASING ESTABLISHMENT - Leasing or renting of automobiles, motorcycles, and light load vehicles.

AUTOMOBILE SALES – The use of any building or portion thereof, or other premises or portion thereof, for the display, sale, rental, or lease of new motor vehicles, or used motor vehicles as an ancillary use of a zoning lot, and any warranty repair work and other repair service conducted as an accessory use.

AUTOMOBILE SALES LOT – That area dedicated to the display of vehicles which are for sale or lease. This area is exclusive of any area utilized for off-street parking.

AUTOMOTIVE SERVICE, MAJOR - The replacement of any part or general repair, rebuilding or reconditioning of engines, passenger cars, commercial vehicles or trailers, including body work, framework, welding and major painting service. Above stated is applied to passenger vehicle(s).

AUTOMOTIVE SERVICE, MINOR - The service and maintenance of equipment and parts, including oil change and lubrication, muffler shops, tire sales and installation, wheel and brake shops, automobile detailing, or installation of CB radios, cellular phones, car stereos, or car alarms. Above stated is applied to passenger vehicle(s), and is typically accomplished without keeping vehicle overnight.

AUTOMOBILE/TRAILER SALES AREA - An open area, other than a street, used for the display, sale or rental of new or used motor vehicles or trailers to be displayed, sold or rented on the premises.

AWNING - Any structure made of cloth or metal with a frame attached to a building, when the same is so erected as to permit its being raised to a position flat against the building when not in use.

B

BACK-OUT AISLE - The area behind a parking space for the purpose of providing maneuvering room for a vehicle to pull in and out of a parking space.

BAIT SALES – An establishment that sells bait such as minnows, crickets, worms, and other similar bait and other fishing gear used for recreational fishing.

BAKE SALE – A fundraising activity where baked goods such as doughnuts, cupcakes, cookies, & ethnic foods are sold.

BAKERY OR DELICATESSEN - An establishment primarily engaged in the retail sale of baked products for consumption off site. The products may be prepared either on or off-site. Such use may include incidental food service.

BALCONY - A stick-built platform which is a horizontal extension from an upper-level floor and which is generally enclosed on three sides by a parapet or railing and is utilized in a manner similar to a deck or terrace.

BALLROOM – A large room used for dances.

BANK – An establishment for the custody, loan, exchange, or issue of money, for the extension of credit, and for facilitating the transmission of funds.

BANNER – A sign of lightweight, flexible, and temporary material such as cloth or plastic that is attached to a building, structure, or other support in such a manner as to allow movement caused by the atmosphere.

BANNER, FIXED – A sign of lightweight fabric or similar material that is permanently mounted to a pole or building by a permanent frame at two or more edges.

BANQUET HALL - A facility or hall available for lease by private parties.

BARRIER, FLYWAY – Fencing, dense hedging or obstacle, or combination thereof, which provides a shield or protective barrier from the direction in which honey bees fly when approaching or leaving a apiary; i.e., a man made or man placed item which causes an alteration in a bees flight pattern.

BASE STATION – A station located at a specific site that is authorized to communicate with mobile stations. The term includes all radio transceivers, antennas, coaxial cables, power supplies, and other electronics associated with a station.

BASEMENT – The portion of a building with more than half of its height below the ground. For the purposes of this Ordinance, a basement shall not be considered a story unless it has been subdivided into rooms and used for tenant purpose.

BATHHOUSE – A use or business that provides the services of baths of all kinds, including all forms and methods of hydrotherapy, unless operated or supervised by a medical or chiropractic practitioner or professional physical therapist licensed by the state.

BATTERY STORAGE, COMPOUND – The fenced area which encloses the land upon which battery storage units are to or have been placed. Land area used for the infrastructure required to connect the battery storage units to a utility service is not included.

BATTERY STORAGE, FIELD – An area of land dedicated primarily for the purpose of locating multiple (more than 3) large, commercial battery storage units which are intended to capture power from an energy production source for future release to the electrical grid.

BATTERY STORAGE, RETROFIT – The placement of large, commercial battery storage units within an established (permit approved) energy production project area.

BATTERY STORAGE, PROJECT AREA – The area defined by the perimeter property lines, (those property lines not shared with another participating property owner) of all parcels/lots of land identified as participating property owners in a common battery storage field, including any abutting rights-of ways captured within two or more participating properties.

BATTING CAGES, COMMERCIAL – A structure in which a batter practices, typically consisting of three sides and a top in utilizing netting or fence material to contain missed or fouled pitches and are available for use for at a set fee.

BAZAAR – A fair for the sale of articles or goods generally for charitable purposes.

BEACON – Any light with one or more beams directed into the atmosphere or directed at one or more points not on the same zone lot as the light source; also, any light with one or more beams that rotate or move.

BED AND BREAKFAST - A short term rental unit operating out of a residential structure, other than a boarding house, where the operator of the establishment resides on the premises or adjacent premise. A Bed & Breakfast offers short-term rentals which last less than 30 days and which includes sleeping accommodations and a morning meal. A B&B consists of no more than six (6) sleeping rooms and may have shared bathroom facilities. The facility offers a common kitchen and dining area. Use is restricted to a single-family dwelling unit with additional rooms utilized for short term rentals. If approved by the Area Board of Zoning Appeals, such a facility may facilitate large group activities such as weddings, anniversaries, retirement celebrations, bachelor/bachelorette parties, etc. In these cases, the owner must demonstrate to the Board that the facility provides adequate parking, individual capacity, safe pedestrian circulation and any facility needs deemed appropriate by the Board of Zoning Appeals.

BEE, COLONY – An entire honey bee family or social unit living together including the queen, workers and drones.

BEE, DOMESTIC HONEY – A classification of bee limited to the Apis mellifera species and specifically excludes the African honey bee, Apis mellifera scutellata or any hybrid thereof.

BEEKEEPER – A person(s) who owns or controls a Beehive(s) or bee house(s), or combination thereof, or a person(s) responsible for the keeping of Domestic Honey Bees.

BEEHIVE (HIVE) – Any naturally created domicile for honey bees.

BEEHIVE, ASSISTED – An enclosed frame or structure, erected with the assistance of humans and used or employed as a domicile for honey bees.

BIO-MEDICINE – A facility or operation which applies biology and physical sciences to clinical medicine.

BIO-PROCESSING, PLANT – A facility where processes or techniques utilizing biological agents, microorganisms, biologically derived macromolecule, living cells or their components, carry out enzymatic reactions or to manufacture products or produce a desired end product.

BLIGHTED AREA - An area in which normal development and occupancy are undesirable or impossible because of: lack of development; cessation of growth; deterioration of improvements; character of occupancy; age; obsolescence; substandard buildings; or other factors that impair value or prevent a normal use or development of property. Refer to IC 36-7-1-3, as amended.

BLOCK - A tract of land bounded by streets, or by a combination of streets and railroad rights-of-way, waterways, boundary lines of municipalities, or other barriers.

BLOCK FACE - The properties abutting on one side of a street and lying between the two nearest intersecting streets.

BOARD - The White County Board of Zoning Appeals (BZA).

BOARDING HOUSE/ROOMING HOUSE – An owner occupied, single family dwelling other than a motel, hotel or lodge, where for compensation and by arrangement, lodging is provided. Meals may or may not be provided, but there is one (1) common kitchen facility. No meals are served to outside guests.

BOAT SALES AND SERVICE – A marine retail sales and service use in which boats or personal water craft are rented or sold. The sale or rental of smaller boats shall be defined as a major durables sales and service use.

BOAT STORAGE, COMMERCIAL – A facility or area where boats are stored for a fee.

BOAT, WATERCRAFT – Any vehicle designed for travel on water that uses an outboard motor, inboard motor or a water jet pump as its sole source of power.

BODY PIERCING – The piercing of holes in parts of the body, other than the ear, in order to insert jewelry or other decorative objects.

BOND - A form of security including a surety bond, in an amount and form satisfactory to the Area Plan Commission.

BOTANICAL GARDEN/BOTANIC GARDEN/ BOTANICAL INSTITUTION – A garden for the culture of plants collected for scientific, educational and ornamental purposes which may include an outdoor garden area(s), one or more greenhouse, herbarium and arboretum areas, library and research laboratory.

BOTTLED GAS STORAGE AND DISTRIBUTION YARD – A commercial operation in which the primary business is a storage yard where bottled gas is stored, distributed, or sold, wholesale or retail. Not included are storage, distribution and use as part of a farm operation.

BOWLING ALLEY - An indoor facility for the sport of ten-pin or duck-pin- bowling, with customary accessory uses such as snack bars.

BREEZEWAY - A roofed structure which is open on two sides and which connects a home to a second structure via a roofline (normally a garage).

BREW PUB – A producer of beers and malt beers with annual production levels less than 15,000 barrels (1 barrel = 31 gallons) which brews and sells its production on-site in packaged or unpackaged form where 25% or less of its production is sold off-site. The establishment may or may not sell signature and/or gift items, complimentary products and/or food within the confines of their retail floor space; however, food sales may not exceed 50% of total sales (having annual food sales in excess of 50% establishes a restaurant for purposes of this Ordinance). No outside storage of finished products, raw materials or process related items (such as barrels, bottles, cases, etc.) takes place. The business and its site must comply with any federal, state or local laws, statutes or regulations in addition to Zoning Ordinance requirements.

BREWERY – A business which manufactures beers and malt beers at a level of 6,000,000 US barrels (1 barrel = 31 gallons) or more for distribution and does not offer on-premise, retail sales of its beverages; although, it may provide a tasting room and have retail space where signature and gift items are made available for sale. There are no beer sales conducted on-site in either packaged or unpackaged form. The business will generally have outside storage of materials and supplies related to the production or distribution of their products. The business and its site must comply with and federal, state or local laws, statutes or regulations in addition to Zoning Ordinance requirements.

BREWERY, CRAFT – A small, independent producer of beer and malt beers with annual production levels not exceeding 6,000,000 US barrels (1 barrel = 31 gallons) and does not offer on-premise, retail sales of its beverages; although, it may provide a tasting room and have retail space where signature and gift items are made available for sale. There are no beer sales conducted on-site in either packaged or unpackaged form. The business will generally have outside storage of materials and supplies related to the production or distribution of their products. A craft brewery cannot be more than 24% owned by another alcoholic beverage company that is not itself a craft brewery. The business and its site must comply with any federal, state or local laws, statutes or regulations in addition to Zoning Ordinance requirements.

BREWERY, MICRO – A producer of beers and malt beers with annual production levels less than 15, 000 barrels (1 barrel = 31 gallons) where on-premise, retail beer and malt beer sales in packaged and unpackaged form occur but do not exceed 25% of the location's annual production. The establishment may or may not sell signature and/or gift items, complimentary products and food within the confines of their retail floor space; however, food sales may not exceed 50% of total sales (having annual food sales in excess of 50% establishes a restaurant for purposes of this Ordinance). No outside storage of finished products, raw materials or process related items (such as barrels, bottles, cases, etc.) takes place. The business and its site must comply with any federal, state or local laws, statutes or regulations in addition to Zoning Ordinance requirements.

BUFFER AREA – Land area used to visibly separate one use from another or to shield or block noise, lights, or other nuisances.

BUILDER – A person, firm, company, or entity who is responsible for the construction related to an issued Building Permit(s).

BUILDING - A structure having a roof supported by columns, extended joists or walls, for the enclosure, support or protection of persons, animals, chattels or other property.

BUILDING AREA - The maximum horizontal projected area of the principal and accessory building, excluding open steps or terraces, unenclosed porches not exceeding basements, or architectural appurtenances.

BUILDING, AGENCY OR DEPARTMENT – A building which houses one or more departments or agencies of a branch of government and which does not utilize outside storage, heavy truck traffic, industrial type of but not be limited to, Highway or Street Department, Fire Department, Police Department or Ambulance Service.

BUILDING, ATTACHED - A building that is structurally connected to another building by foundation, common wall, or roofline. Future expansion of a building shall be connected by foundation, common wall, Roofline, or breezeway.

BUILDING CODE - The County ordinance establishing and controlling the standard for constructing buildings, utilities, mechanical equipment and all forms of structures and permanent installations and related matters, within the County. It also referred to herein as the Building Code of the County of White, Indiana, Ordinance No. 01-03-05-01 and amendments thereto.

BUILDING COMMISSIONER - Building Commissioner shall be synonymous with the term Building Inspector, and shall refer to the person employed and delegated the primary responsibility of issuing building permits and conducting inspections of same.

BUILDING, DETACHED - A building having no structural connection with another building.

BUILDING, GOVERNMENT – A building that houses a branch of government.

BUILDING, HEIGHT OF - The vertical distance from the finished ground level at the wall of the building nearest and most parallel to the front lot line (measured as an average of the ground level at its two furthest corners). Chimneys, spires, towers, elevator penthouses, tanks and similar projections other than signs shall not be included in calculating the height.

BUILDING PERMIT – A certificate issued by the Administrative Officer, permitting a person, firm or corporation to erect, construct, enlarge, alter, repair, move, improve, remove, convert, or demolish any building or structure within its jurisdiction, or cause the same to be done.

BUILDING, PRINCIPAL - A building in which the primary use of the lot on which the building is located is conducted.

ACCESSORY STRUCTURE AND PRINCIPAL BUILDING DEFINITION

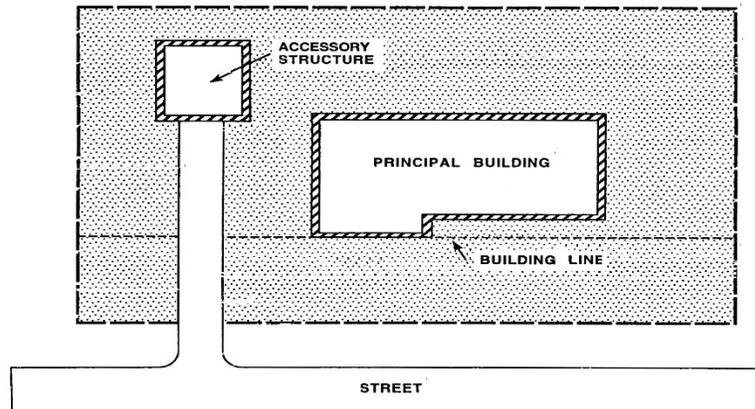

BUILDING SETBACK - A line parallel to and equidistant from the relevant lot line (front, back, side) measured from the property line, defining the limits of a yard in which no building, other than a permitted accessory building or structure, may be located above ground, except as may be provided by the Development Standards in this Ordinance. The setback is measured to the foundation of the building unless the structure has an overhang greater than sixteen (16) inches, in which case the setback is measured to the overhang.

BUILDING SITE - An area proposed or provided by grading, filling, excavating or other means for erecting pads, slabs, or foundations for buildings.

BUILDING SIZE - The gross, horizontal area within the perimeter of the exterior walls of the building located on the first or nearest ground level floor excluding open areas or terraces; unenclosed porches, decks and/or protruding architectural features.

BUILD-TO-LINE - An alignment established a certain distance from the right-of-way line to a line along which the building shall be built.

BUNKHOUSE - An accessory structure, or portion thereof, which provides temporary sleeping quarters for the sole use of persons employed on the premises. Such quarters shall not be rented or otherwise used as a separate dwelling unit. Such quarters may have plumbing facilities such as a sink, toilet and/or shower but are not allowed to have kitchen facilities.

BUS - A vehicle with capacity of eight (8) or more passengers which charges a fare to transport people from one point to another, usually along a pre-determined route, or is chartered by a large group to go from one point to another. The driver is an employee or volunteer of a company or organization

BUS LOT - Any lot or land area used for the storage or layover of passenger buses or motor coaches.

BUS GARAGE - A building or portion thereof, privately owned and operated, used for the storage, maintenance or service of commercial buses.

BUS STATION, PASSENGER - Any premises for the transient housing or parking of motor driven buses, and the loading and unloading of passengers.

BUSINESS - The engaging in the purchase, sale, barter or exchange of goods, wares, merchandise or services; or the maintenance or operation of offices; or the maintenance or operation of recreational and amusement enterprises for profit.

C

CABANA – A shelter resembling a cabin or hut usually with an open side facing a beach or swimming pool. Usually used as a beach or pool accessory structure.

CABIN (Mini Vacation Home) – A building with minimum living space of 300 square feet usually containing only sleeping rooms, a small gathering room, lavatory and a kitchenette or small kitchen and which is available for rent on a short-term basis (less than 30 days). A cabin will be treated as a permitted (allowed) use in any State Regulated Camp Ground or Mobile and Manufactured Home Park regardless of the zoning district in which the Camp Ground or Park is located and permitted (allowed) in any AED District; otherwise is subject to Special Exception Use approval from the Area Board of Zoning Appeals and must meet the Special Exception Use Standards of a Vacation Home.

CAMPGROUND- A primitive and/or improved parcel of land used or intended to be used for temporary occupancy by campers, through the use of recreational vehicles, travel trailers, mobile homes, tents, cabins, or other temporary accommodations.

CANOPY – Any structure, other than an awning, made of cloth, metal or wood with frames attached to a building, projecting over a sidewalk.

CAR WASH - An area of land and/or a structure with machine or hand operated facilities used principally for the cleaning, washing, polishing, and/or waxing of motor vehicles.

CARETAKER HOME – A permanent residence, secondary and accessory to an existing main dwelling for persons employed principally on-site for purposes of care and protection of persons, property, plants, animals, equipment or other circumstances on-site or on contiguous lots under the same ownership.

CARNIVAL – A traveling amusement establishment usually including rides, games, and sideshows.

CARPORIT - A covered automobile parking space not completely enclosed by walls or doors and is open on at least two sides.

CASINO – A building in which one or more gaming tables, wagering devices or machines, or other games of chance are present and available for persons to wager money or something of value on an uncertain outcome, with an unassured prospect of winning money or other stakes, prizes, or something of value, including by way of illustration, but not limitation: bingo, keno, raffles, video poker, roulette, pari-mutuels, blackjack and other card games; excluding those gambling or gaming establishments whose location and/ or right to operate is preempted by state law.

CATERING SERVICE – An establishment that serves and supplies food to be consumed off premises.

CEMETERY - Land used for the burial of the dead and dedicated for cemetery purposes, including columbariums, crematories, mausoleums and mortuaries when operated in conjunction with and within the boundary of such cemetery.

CERTIFICATION OF OCCUPANCY - A certificate signed by the Building Commissioner stating that the occupancy and use of land or a building or structure referred to therein complies with the provisions of this Ordinance and other applicable County Ordinances.

CHICKEN – A domestic fowl (*gallus domesticus*), a subspecies of the red junglefowl.

CHICKEN COOP (HEN HOUSE) – A structure for the sheltering of chickens.

CHICKEN HEN – A common, female chicken or its young up to 12 weeks of age.

CHICKEN PEN – A contained area that is connected to and/or surrounding a chicken coop for the purpose of allowing chickens to leave a chicken coop while remaining in an enclosed, predator safe environment.

CHILD CARE CENTER – A non-residential building where at least one (1) child receives child care from a provider;

- (1) While unattended by a parent, legal guardian, or custodian;
- (2) For regular compensation; and
- (3) for more than four (4) hours but less than twenty-four (24) hours in each of ten (10) consecutive days per year, excluding intervening Saturdays, Sundays, and holidays; as defined in IC 12-7-2-28.4 as amended.

CHILD CARE HOME – A residential structure that serves any combination of full-time and part-time children in accordance with IC 12-7-2-33.7 (Class I) and IC 12-7-2-33.8 (Class II)

CHILD CARE HOUSE – A residence in which no more than five (5) children at any time receive child care from a provider, not including the children for whom the provider is a parent, step-parent, guardian, custodian, or other relative or any child who is at least fourteen (14) years of age and does not require child care.

CHILDREN’S PLAY EQUIPMENT – Age-appropriate recreational equipment that enables children to develop physical coordination, strength and flexibility as well as providing recreation and enjoyment.

CHRISTMAS TREE SALES - A retail sales operation generally conducted wholly out-of-doors, that offers for sale on a temporary, limited basis Christmas trees and related holiday items such as wreaths and Christmas tree stands.

CIRCUS – A form of entertainment typically presented in one or more very large tents or an outdoor and/or indoor area featuring exhibitions of pageantry, feats of skill and daring with a variety of performances by acrobats, trapeze artists, clowns and trained animals.

CLUB OR LODGE, PRIVATE - Building and facilities owned or operated by a person or organization for a social, educational, or recreational purpose, but not primarily for profit or to render a service which is customarily carried on as a business.

COLLOCATION – The placement or installation of a wireless facility on existing structures that include a wireless facility or a wireless support structure, including water towers and other buildings or structures.

COMMERCIAL SOLAR ENERGY SYSTEM (See SOLAR ENERGY SYSTEM, COMMERCIAL)

COMMISSARY – An establishment where food is stored, prepared, portioned, or packaged or any combination of these, where such food is intended for consumption at another establishment or place. It is also the place which is used as the base operations for one or more mobile food service vehicles or push carts, where such unit or units are serviced, cleaned, supplied, maintained, and where equipment, utensils and facilities are serviced, cleaned and sanitized.

COMMISSION - The White County Area Plan Commission.

COMMISSIONERS, COUNTY - Whenever the term “Commissioners” is used in this Ordinance, it shall mean the Board of County Commissioners of White County, Indiana, unless otherwise designated.

COMMUNICATIONS EQUIPMENT BUILDING - An unmanned building or cabinet containing communications equipment required for the operation of communications antennas.

COMMUNICATIONS SERVICE PROVIDER – A person or entity that offers communications service to customers in Indiana, without regard to the technology or medium used by the person or entity to provide the communications service. This term includes a provider of commercial mobile service as defined in 47 U.S.C. 332.

COMMUNICATIONS TOWER, HEIGHT OF - revised and moved to “W’s”

COMMUNICATIONS TOWER, MONOPOLE - revised and moved to “W’s”

COMMUNITY CENTER – A building utilized by members of a community for social or cultural activity which may include facilities for recreational purposes.

COMMUNITY COMMONS - An area of land not more than 20,000 square feet, normally located within an urban area and along a pedestrian corridor, committed to providing a public place for short term rest and relaxation and which does not include recreational facilities but which might include various types of seating arrangements and other low-key amenities.

COMPACT HOUSE - A free standing light framed or masonry constructed home which is utilized as a primary dwelling and which has not less than 300 square feet or more than 600 square feet of living space.

COMPREHENSIVE PLAN - The official policy document which establishes development goals and objectives to guide growth within and around White County in a coordinated manner, prepared by the White County Area Plan Commission and adopted in accordance IC 37-7-4 500 Series.

CONCESSION STAND – An accessory structure or portion of a principal structure utilized for the sale of concessions.

CONCESSIONAIRE – A person, firm, business or other entity that sells concessions from a concession stand.

CONCESSIONS – The sale of confections, snacks, or other light meals and providing no inside seating nor drive-in service for the customers.

CONCRETE OR CEMENT BATCHING PLANT, PERMANENT – A manufacturing plant, utilizing at least some permanently secured pieces of equipment, where concrete is mixed before being transported to a construction site ready to be poured.

CONCRETE OR CEMENT BATCHING PLANT, PORTABLE – A manufacturing plant where the equipment is installed on a temporary basis and concrete is mixed at or next to the construction site with capacities limited to 2,000 yards or less per day.

CONDOMINIUMS - A form of property ownership where a multiple dwelling or development containing individually owned dwelling units and jointly owned and shared areas and facilities, which dwelling or development is subject to the provisions of Indiana and other applicable local laws.

CONFERENCE CENTER/MEETING HALL – A building or large room used for meetings, conferences, public or social gatherings or entertainment activities which may allow catering services or provide a kitchen for use by event sponsors.

CONFERENCE FACILITY - A facility used for service organizations, business and professional conferences and seminars limited to accommodations for conference attendees. The accommodations can include sleeping, eating and recreation.

CONFINED FEEDING OPERATION- The confined feeding of animals for food, fur, or pleasure purposes in lots, pens, ponds, sheds, or buildings where, animals are confined, fed, and maintained, excluding a livestock market where animals are assembled to be publicly auctioned or privately sold on a commission basis and that is under state or federal supervision; or as otherwise defined by the Indiana Department of Environmental Management.

CONSERVATION LANDS, PUBLIC – Land owned in fee title by any city, county, state, or federal agency, or non-profit conservation organizations, and managed specifically for conservation purposes.

CONSERVATORY - A room with a glass roof and walls, attached to a house or other building at one side and used as a greenhouse or a sun parlor.

CONSTRUCTION BUILDING – A mobile home, travel trailer, truck trailer, or other structure used as an office in conjunction with a construction project.

CONSTRUCTION, HEAVY CONTRACTORS - The process of adding infrastructure to our built environment. Owners of these projects are usually government agencies, either at the national, state or local level. Unlike building construction, heavy/civil construction projects are not typically undertaken for-profit. Rather, the projects are intended to service the public interest.

CONSTRUCTION YARD - An area on or immediately adjacent to a major construction or demolition site used on a temporary basis for the parking and storage of equipment used in the project, and the storage and preparation of materials and other items used in the project. Such yard may include construction offices and such shops as are necessary for work on the immediate site.

CONVENIENCE STORE, NEIGHBORHOOD - A retail store that sells groceries and household items, but does not have restaurant seating or gasoline sales.

CONVENIENCE STORE, REGIONAL - A retail store that sells groceries and household items, and which may also provide other convenience services such as restaurant, laundromat or vehicular fuel sales for class I or II commercial vehicles. Such uses are considered to be accessory uses and not a separate business.

CONVENTION CENTER/EXHIBITION HALL – A building or group of buildings which are designed for the primary use of housing conventions, industrial shows, exhibitions and the like where individuals and groups gather to promote and share common interests. These facilities make available large, unobstructed exhibit areas and also may include conference rooms, hotel accommodations, restaurants and other amenities for the benefit of attendees and/or exhibitors and may be used to accommodate sporting events, circus type activities, rodeos, entertainment events or other uses requiring a large venue.

CONVERSION - A change in the use of land or structure.

CORRECTIONAL/PENAL FACILITY - Public or privately-operated facilities housing persons awaiting trial or persons serving a sentence after being found guilty of a criminal offense.

COTTAGE/SUMMER HOME – A building with minimum living space of 300 square feet, utilized by its owner as temporary housing for vacationing or rest and relaxation, but not utilized as a primary or year-round dwelling or for rental purposes.

COUNTY - White County, Indiana.

COURT - An open, unoccupied and unobstructed space other than a yard on the same lot with a building or group of buildings.

COVENANT - A private legal restriction on the use of land contained in the deed to the property and otherwise formally recorded.

CREMATORY - A furnace or establishment for the incineration of corpses.

CULVERT - A drainpipe that channels water under a bridge, street, or driveway.

CUT - The material removed in excavation. The difference between a point on the original ground and a designated point of lower elevation on the final grade.

D

DAY CARE CENTER, ADULT - A facility providing care for the elderly and/or functionally impaired adults in a protective setting for a portion of a twenty-four (24) hour day.

DECK - 1) A stick-built platform which is located adjacent to a building or structure and is constructed at or above the first (main) floor level of the building, but not at an elevation beyond the height of the first floor level of a building; 2) A stick built platform which is located away from a building, typically adjacent or near a water source and which is located no more than six feet above grade.

DEDICATION – The transfer of private property to public ownership upon written acceptance.

DENSITY - The number of dwelling units permitted per gross acre of land.

DEPARTMENT STORE – A retail store that sells a wide variety of goods arranged in several departments.

DETENTION AREA - An area that is designed to capture specific quantities of storm water and to gradually release the storm water at a sufficiently slow rate to avert flooding.

DEVELOPER - The owner of land or his representative proposing changes to a parcel or parcels of land, including development, lot improvement or subdivision of land.

DEVELOPMENT - Any man-made change to improved or unimproved real estate including but not limited to construction, reconstruction, or placement of a building or any addition to a building which increase its usable space. The term “development” does not include activities such as the maintenance of existing buildings and facilities such as painting, re-roofing, resurfacing roads, or gardening, plowing, and similar agricultural practices that do not involve filling, grading, excavation, or the construction of permanent buildings.

DEVELOPMENT STANDARDS - Regulations such as bulk, height, area, or open space requirements set forth by ordinance approving the proposed development.

DIGESTER - A vessel or tank in which organic or chemical reactions take place for the decomposition of human or animal waste and other organic waste products. A digester is considered an accessory use when the electricity and/or gas produced by the digester is used entirely on site. A digester is considered a commercial use when some or all of the electricity and/or gas produced by the digester is sold to an off-site party.

DIGESTER, AEROBIC – A process by which microorganisms access free gaseous oxygen from the surrounding atmosphere and, thereby, are able to convert, suspend or dissolve waste products into alternative forms.

DIGESTER, ANAEROBIC – A process by which microorganisms, in the absence of gaseous oxygen, convert waste products into a biogas which is then burned to produce heat, electricity and water.

DISTILLERY - A processing facility where distilling of alcoholic liquors takes place in large volume (annual production greater than 1700 cases or 4,041 gallons of finished product). All products are distributed to off-site, unrelated, commercial entities with no on-site retail sales of their products. The business may have a tasting room and offer signature or other gift items for sale. The business will typically have outside storage of product and supplies affiliated to production and distribution of their products. The business and its site must comply with any federal, state or local laws, statutes or regulations in addition to Zoning Ordinance requirements.

DISTILLERY, MICRO OR BOUTIQUE – A small processing facility where distilling of alcoholic liquors takes place and which is limited in production to no more than 1700 cases or 4,041 gallons of finished product a year. A micro or boutique distillery may also operate a tasting room, provide retail sales of their packaged product, retail sales of signature and gift items and provide food service where food service is limited to no more than 50% of total sales (having annual food sales in excess of 50% establishes a restaurant for purposes of this Ordinance). No outside storage of finished products, raw materials or process related items (such as barrels, bottles, cases, etc.) takes place. The business and its site must comply with any federal, state or local laws, statutes or regulations in addition to Zoning Ordinance requirements.

DISTRIBUTION CENTER - A use where goods are received and/or stored for delivery to the ultimate customer at remote locations.

DRAINAGE SYSTEM - All facilities, channels, and areas, which serve to convey, filter, store, and/or receive storm water, either on a temporary or permanent basis.

DRAKE – A male aquatic bird or waterfowl with a broad blunt bill, short neck and legs, webbed feet and a waddling gait in the family Anatidae. The word does not include swans and geese.

DRIP LIINE - The imaginary circle drawn on the soil around a tree directly under its outermost branch tips; the boundary of a tree's canopy.

DRIVE-UP WINDOW – Any establishment providing service from a building directly to a customer in an automobile or other vehicle.

DRIVEWAY – A paved, concrete, graveled or dirt access strip of land which has not been dedicated to the public and which is used for vehicular access between a public way or private road and the improvements on one or more lots, parcels or tracts of land.

DRIVING RANGE – An area equipped with distance markers, clubs, balls, and tees for practicing golf drives.

DRUG STORE - A retail store where medicines and miscellaneous articles are sold.

DUCK – A female aquatic bird or waterfowl with a broad blunt bill, short neck and legs, webbed feet and a waddling gait in the family Anatidae. The word does not include swans and geese.

DWELLING - A building or portion thereof, used as a place of residence for one or more human beings, but not including mobile homes, hotels or motels, lodging or boarding houses.

DWELLING, ATTACHED SINGLE-FAMILY - Single-family dwelling units attached by a common wall or walls, and legally platted so that each unit sits on an individual lot providing for fee simple ownership of each lot. This type of dwelling may or may not have additional common grounds owned by a homeowner's association.

DWELLING, FARM - A dwelling, located on a farm, for the purpose of housing an owner or employee of that farm or agricultural operation and his/her family.

DWELLING, MULTI-FAMILY - A single, residential structure consisting of three (3) or more dwelling units. These units are to be occupied by one family each. The dwelling units may or may not be located in a single structure.

DWELLING, SINGLE FAMILY - A free-standing, detached residential structure which consists of one (1) dwelling unit per lot to be occupied by one (1) family.

DWELLING, STUDENT/FRATERNITY/SORORITY – A building or buildings with the primary use of providing temporary housing for students, fraternity or sorority members or for people with temporary educational needs, but not including hotels, motels, resorts, boarding or rooming houses.

DWELLING, TWO FAMILY (DUPLICATE) – Dwelling, Two Family, or Duplex: A single, free-standing, detached residential structure which consists of two (2) dwelling units where each dwelling unit is occupied by one family and has direct access to the outside.

DWELLING UNIT - A dwelling or part of a dwelling used by one family as a place of abode, physically separated from any other dwelling units which may be in the same structure and containing independent cooking, bathroom and sleeping facilities.

DWELLING UNIT, SUBORDINATE: A free-standing, single-family dwelling unit which does not exceed 75% of the gross floor area of the primary dwelling unit. Subordinate dwelling units may not be used for short-term rental purposes. A property which includes a principal dwelling unit may not also include an apartment or accessory apartment on the property.

E

EASEMENT - The right of a person, government agency, or public utility company to use, for a specific purpose, the public or private land owned by another.

EDUCATIONAL FACILITY, OTHER – A facility, outside an elementary, secondary or collegiate institution, where individuals are taught specific skills in areas such as manufacturing or construction trades, dancing, singing, arts, business or where specialized technical training is provided.

EDUCATIONAL FACILITY, PRIVATE - Any building or group of buildings, the use of which meets state requirements for primary, secondary, or higher education and which does not secure the major parts of its funding from any governmental agency. This includes any and all related uses, such as ball fields, batting cages, tennis courts, concessions, etc.

EDUCATIONAL FACILITY, PUBLIC - Any building or group of buildings, the use of which meets state requirements for primary, secondary, or higher education and which secures the major parts of its funding from governmental agencies. This includes any and all related uses, such as ball fields, batting cages, tennis courts, concessions, etc.

EDUCATIONAL INSTITUTION - A pre-primary, primary, grade, junior high, high, or preparatory school or academy; or a junior college, college or university, whether public or founded or conducted by or under the sponsorship of a religious or charitable organization.

EGRESS – An exit.

ELECTRIC FOOT SCOOTER – A device:

- 1) Weighing not more than one hundred (100) pounds;
- 2) Designed to travel on not more than three (3) wheels in contact with the ground;
- 3) With handlebars and a floorboard that the rider uses to stand on the device during operation; and,
- 4) Powered by an electric motor that is capable of powering the device with or without human propulsion at a speed not more than twenty (20) miles per hour on a paved level surface.

The term does not include a motor driven cycle, motor vehicle or motorcycle.

ELECTRIC VEHICLE CHARGING STATION (EVCS) – Equipment that connects an electric vehicle to a source of electricity for the purpose of recharging the vehicles battery(ies). Such charging stations may be utilized for, but not limited to, electric cars, hybrid vehicles, electric trucks, electric buses, golf carts and other neighborhood electric vehicles.

ELECTRIC VEHICLE CHARGING STATION, ACCESSIBLE – An EVCS which provides site features which facilitate service and equipment access by ADA qualified individuals.

ELECTRIC VEHICLE CHARGING STATION, PRIVATE – A charging station where access is restricted to a property owner, including family, friends and relatives, or to individuals with direct affiliation to a site's operations (such as executives and employees, but not to customers, visitors or general membership such as in a co-op, club or lodge). Each Private EVCS is exempt from the requirement to obtain an Improvement Location Permit

ELECTRIC VEHICLE CHARGING STATION, PUBLIC – A charging station which is available to the general public, whether free or for a fee. Each Public EVCS requires an Improvement Location Permit.

ENGINE REPAIR, SMALL - A facility where the primary business activity is the repair, maintenance and replacement of small engines, motors and other power components as well as service, repair, maintenance and reconstruction of small power devices such as, but not limited to, hand mowers, riding mowers, weed eaters, house hold generators, small appliances, hedge trimmers, electric heaters, and similar types and sized items. The facility will typically offer retail sales as a complimentary service secondary to the repair operations.

ENGINEER, PROFESSIONAL - Any person who is licensed by the State of Indiana to practice professional engineering.

ENTERTAINMENT FACILITY, COMMERCIAL – A building, structure or use of land utilized to provide for profit entertainment venues such as concerts, movies, theatrical productions, etc.

ENTRANCE DRIVE - Portion of a driveway which immediately abuts the public right-of-way or a private street.

EQUIPMENT SALES AND LEASING - The retail or wholesale sale or rental of heavy motorized vehicles or equipment, along with incidental service or maintenance such as, but not limited to construction equipment rental yards, tractor-trailers, semi-trailers, boats, buses, recreational vehicles, farm equipment and moving trailer rental.

EROSION - The removal of surface materials by the action of natural elements.

ESSENTIAL SERVICES – Services that have been viewed to be necessary to a basic standard of living and the general welfare of society, and therefore have traditionally been supplied publicly in order to ensure the broadest level of access for citizens. These services may include water, sanitation, electricity, cable, phone and fiber optics. For the purposes of the administration and enforcement of the White County Zoning Ordinance, the term essential services shall not include feeder lines installed as part of any Wind Energy Conversion System.

ETHANOL PLANT – A facility that produces ethanol.

EVENT, BARN - A building, either with or without an outdoor component, dedicated to providing a venue for weddings, anniversaries, family reunions or other large gatherings of people. Attendance is by invitation or reservation only. The facility may include a multi-use area for eating, dancing, music, entertainment or other festivities associated with celebratory or official gatherings and may also include a kitchen, bar or other amenities utilized for these types of occasions. Events open to the public without the requirement of invitation or reservation are only allowed under a Temporary Use Permit issued by the Staff and shall not be valid for more than three days; such permits may be granted no more than four (4) times per calendar year.

EVENT, GOVERNMENT – Any coordinated activity approved by any Local or State legislative body.

EVENT, SPECIAL – A one-time or infrequently occurring activity held by a private group of persons, firm, organization, association, non-profit entity or business which occurs unrelated to the principal use of the property.

EVENT, SPORTING - An athletic activity requiring skill or physical prowess and often of a competitive nature such as, but not limited to, baseball, tennis, bowling, horseshoes, hunting, bean bag and fishing.

EXCAVATION - Any act by which earth, sand, gravel, rock or any other similar material is dug into, cut, quarried, uncovered, removed, displaced, relocated or bulldozed. Shall also include the conditions resulting there from.

EXECUTIVE DIRECTOR – The individual appointed by the Area Plan Commission or his designee to direct the activities of the planning department and whose duties are established in IC 36-7-4-312.

EXPLOSIVE MANUFACTURING – The manufacturing of any chemical compound mixture or device, the primary and common purpose of which is to function by explosion with substantially simultaneous release of gas and heat, the resulting pressure being capable of producing destructive effects.

EXPLOSIVES, USE OR STORAGE – The use or storage of any chemical compound mixture or device, the primary and common purpose of which is to function by explosion with substantially simultaneous release of gas and heat, the resulting pressure being capable of producing destructive effects.

F

FACILITY, WIRELESS - A set of equipment and network components necessary to provide wireless communications service. The term does not include a wireless support structure.

FAIRGROUNDS – An outdoor area where fairs or exhibitions are held.

FAMILY - One or more persons occupying a single dwelling unit, living together as a single housekeeping unit, and sharing common living, sleeping, eating and cooking facilities. Family does not include any group living in a boarding house, hotel, club, fraternity, sorority, or rooming house.

FARM - A tract of agricultural zoned land which is devoted to agricultural operations such as forestry; the growing of crops; pasturage; the production of livestock and poultry; the growing of trees, shrubs and plants; and other recognized agricultural pursuits; and including accessory buildings essential to the operation of the farm. Accessory buildings may include barns; equipment and animal sheds; farm residences for the owner, operator or farm assistants; roadside sales structure for the sale of products of the farm; and signs displaying subject matter directly related to the name of the products of the particular farm. "Farms" shall not include industrial or commercial operations or structures, which are not directly related to agricultural production.

FARM CHEMICAL/FERTILIZER SUPPLIER – Any legal entity which stores, processes or prepares chemicals or fertilizers for the farm or agricultural community.

FARMING, MICRO – Any category of livestock; also, honey bees, which have been determined, under restricted conditions and within certain attributes as defined by Ordinance, to be suitable for raising, breeding or for personal use, in residential districts.

FEDERAL EMERGENCY MANAGEMENT AGENCY (FEMA) – An independent agency of the United States government that provides a single point of accountability for all federal emergency preparedness and mitigation and response activities

FENCE - An upright structure used to identify a boundary or to provide a means of protection, personal privacy screening or confinement, but not including hedges, shrubs, trees or other natural growth. A fence does not qualify as an enclosure.

FESTIVAL – An organized event which consists of, but is not limited to, entertainment, the sale of packaged and unpackaged food items, temporary retail vendors, sporting events, and other activities associated with carnival, bazaar or flea market operations and conducted with the approval of any local legislative body.

FILL - Any act by which earth, sand, gravel, rock or any other material is placed, pushed, dumped, pulled, transported or moved to a new location above the natural surface of the ground or on top of the stripped surface, including the conditions resulting there from. Also, the difference in elevation between a point on the original ground and a designated point of higher elevation on the final grade, or the material used to make a fill.

FIRE STATION (FIREHOUSE) – A location where fire fighting vehicles and equipment are housed and where fire fighters are on duty or called to on an as needed basis.

FIREWORKS SALES - An establishment, temporary or permanent, that sells any substance or combination of substances or articles prepared for the purpose of producing a visible or an audible effect by combustion, explosion, deflagration, or detonation, and includes blank cartridges, toy pistols, toy cannons, toy canes, or toy guns in which explosives other than toy paper caps are used, firecrackers, torpedoes, sky rockets, Roman candles, Daygo bombs, sparklers, or other fireworks of like construction, any fireworks containing any explosive or flammable compound, or any tablet or other device containing any explosive substance.

FIXTURE - The assembly that holds the lamp (bulb) in a lighting system. It includes the elements designed to give light output control, such as a reflector (mirror) or refractor (lens), the ballast, housing, and the attachment parts.

FLEA MARKET (SWAP MEET) - A market, usually held outdoors, where antiques, used/new household goods, curious, crafts, collectibles or other miscellaneous goods are sold and/or bartered.

FLOOD -- A general and temporary condition of partial or complete inundation of normally dry land areas from the overflow, the unusual and rapid accumulation, or the runoff of surface waters from any source.

FLOOD BOUNDARY AND FLOODWAY MAP (FBFM) – The official map on which the Federal Emergency Management Agency or Federal Insurance Administration has delineated both the areas of flood hazard and the floodway.

FLOOD HAZARD AREA -- A flood plain, or portion thereof, which is not adequately protected from floodwater by means of dikes, levees, reservoirs, or other works approved by the Indiana Department of Natural Resources and Federal Energy Regulation Commission (FERC).

FLOOD HAZARD BOUNDARY MAP (FHBM) -- An official map of a community, issued by the administrator, where the boundaries of the flood, mudslide (i.e., mudflow) related erosion areas having special hazards have been designated as Zones A, M, and/or E.

FLOOD INSURANCE RATE MAP (FIRM) -- The official map on which the Federal Emergency Management Agency has delineated both the areas of special flood hazards and the risk premium zones applicable to the County.

FLOOD PROFILE, REGULATORY - A longitudinal profile along the thread of a stream showing the maximum water surface elevation attained by the regulatory flood. The intent of this definition is to be consistent with the definition derived by the Indiana Department of Natural Resources.

FLOOD PROTECTION GRADE (FPG) – The elevation of the regulatory flood plus two feet at any given location in the Special Flood Hazard Area (SFHA).

FLOOD, REGULATORY – The flood having a one (1) percent probability of being equaled or exceeded in any given year, as calculated by a method and procedure which is acceptable to and approved by the Indiana Department of Natural Resources and the Federal Emergency Management Agency.

FLOODPLAIN – The channel proper and the areas adjoining any wetland, lake or watercourse, which have been or hereafter may be covered by the regulatory flood. The floodplain includes both the floodway and the floodway fringe districts.

FLOODWAY – The channel of a river or stream and those portions of the floodplains adjoining the channel which are reasonably required to efficiently carry and discharge the peak flood flow of the regulatory flood of any river or stream.

FLOODWAY FRINGE – Those portions of the floodplain lying outside the floodway.

FLOOR AREA, GROSS (GSF) - The total horizontal areas of the one (1) or several floors of a building or portion thereof devoted to a particular use, including accessory storage areas located within selling or working space such as counters, racks, or closets and any basement floor area devoted to retailing activities, to the production or processing of goods or to offices; provided, however, gross floor area shall not include that area devoted entirely and permanently to storage purposes, parking and loading facilities, or space used for restrooms, utilities, stairwells or elevator shafts.

FLOOR AREA, NET - The total area, computed on a horizontal plane, used for a particular business category; exclusive of entrances, hallways, stairs and other accessory areas used for ingress or egress.

FOOT-CANDLE – A unit of illumination equal to the illumination at all points that are one (1) foot from a uniform point source of one (1) candle of power.

FOUNDATION - The supporting member of a wall or structure.

FOUNDATION SIDING or SKIRTING – A type of wainscoting constructed of fire and weather resistant material, such as aluminum, treated pressed wood or other approved materials, enclosing the entire undercarriage of the manufactured or mobile home.

FOUNDRY PLANT – A facility where the molding, casting and/or shaping of metals occurs using heat and/or compression.

FULL CUTOFF - A light fixture, which prevents distribution of light above a horizontal plane passing through the lowest point of the bulb or lens, diffuser, reflective enclosure, or other parts intended to distribute light.

FUNERAL HOME OR MORTUARY - An establishment engaged in undertaking services such as preparing the human dead for burial, and arranging and managing funeral services before burial or cremation.

G

GARAGE - A structure, building or part thereof used for the storage, parking, or servicing/repair of Class I and Class II motor vehicles owned by and registered to the property owner or occupant of the lot on which it is situated, including carports. Such use may include storage of non-commercial, personal effects or items.

GARAGE, ATTACHED - A portion of the principal building, used or designed to be used for a garage.

GARAGE, DETACHED An accessory building, or part thereof, used or designed to be used for a garage.

GARAGE/YARD SALE - Also called Rummage Sale, Lawn Sale, Attic Sale, Moving Sale, Garbage Sale, Thrift Sale or Junk Sale. A private or public sale of six (6) or more items of personal property, the sale of which is conducted within a residence, garage, or other accessory building, or immediately outside of such building, and which the owner or occupier of such structure conducts. The sale may include one or more families.

Also, a sale conducted by a non-profit organization of miscellaneous goods, personal property or other articles generally contributed by donors in an effort to raise money for a cause, program, another organization or the organization itself.

GASOLINE SERVICE STATION - An establishment where gasoline and other petroleum products are sold as the principal use of the property. Retail items typically found in a convenience market including prepackaged food items and tangible consumer goods, primarily for self-service by the consumer can be sold. Hot beverages, fountain-type beverages, and pastries may be included in the food items offered for sale, but food items that are prepared or individually proportioned on the premises shall be prohibited. Light maintenance activities such as lubrication, and minor repairs may also be provided if incidental to such principal use.

GO-KART FACILITY – An entertainment facility that uses a small low motor vehicle with four wheels and an open framework for recreational racing on a track.

GOLF COURSE - A tract of land laid out with at least nine (9) holes for playing a game of golf and improved with tees, greens, fairways and hazards. A golf course may include a driving range, pitch and putt area, a clubhouse and shelters as accessory uses.

GOVERNMENT BUILDING – See Building, Government

GOVERNMENT BUILDING DEPARTMENT OR AGENCY – See Building, Department or Agency

GRADE – The elevation established for the purpose of regulating the number of stories and the height of buildings. Grade shall be the mean level of the finished surface of the ground adjacent to the exterior walls of the building.

GRAIN ELEVATOR – A building(s) for elevating, storing, discharging, and sometimes processing grain including related uses or structures.

GRANDSTAND - A usually roofed stand for spectators at a stadium or racetrack.

GREENHOUSE, COMMERCIAL - A greenhouse used for the growing of plants, all or part of which are sold at retail or wholesale.

GREENHOUSE, NON-COMMERCIAL – A small structure where residents grow flowers, shrubs, vegetables and the like for their own private use.

GREENSPACE AREA – That portion of the front yard of a lot that is immediately adjacent and parallel to the right-of-way of US 24 and all county roads within the identified boundaries and from the right-of-way line.

GROCERY STORE OR SUPERMARKET – Stores where most of the floor area is devoted to the sale of food products for home preparation and consumption, which typically also offer other home care and personal care products, and which are substantially larger and carry a broader range of merchandise than convenience stores.

GROUP HOME – A facility for persons who are handicapped, mentally retarded or developmentally disabled, or who because of age or other physical, psychological, or social disabilities, or by reason of relational circumstances may require the protection of a group home setting to care for themselves or to facilitate the transition to a functioning member of society. Refer also to IC 12-7-2-166 and 167.

GUARD SHACKS - A structure built in compliance with all building codes of White County and located on private property for the purpose of manually or electronically monitoring pedestrian or vehicular traffic and promoting security substantially impeding or restricting ingress or egress; provided, however, a guard shack shall not be designed or used for sleeping or living purposes.

GUEST HOUSE – A use of room or rooms within an “accessory building” used for the occasional housing of non-paying guests or occupants of the principal building and not for permanent occupancy by others.

GUN SALES – A place where general retail sales of gun and firearm associated items are bought and sold. All developmental standards for retail sales must be met. A gun smith may be active on-site and perform gun-smith activities. The business and its site must comply with any federal, state or local laws, statutes or regulations in addition to Zoning Ordinance requirements. A shooting range is not included as a permissible use without a Special Exception having been granted.

GUN SMITH – A place where a person provides small firearms related services such as repairs, modifications, designs and building of small firearms along with firearm testing. Sales derived from providing services or selling of firearms individually designed and built by the person on-site are permissible. General retail sales, a retail establishment or a retail sales floor where general gun and firearms sales occur is not permitted. The business and its site must comply with any federal, state or local laws, statutes, and regulations in addition to Zoning Ordinance requirements. A shooting range is not included as a permissible use without a Special Exception having been granted.

H

HARDSHIP - A perceived difficulty with regard to one's ability to improve land as a result of the application of the development standards of this Ordinance.

HATCHERY – A place where eggs, especially those of fish or poultry, are hatched.

HATCHERY, COMMERCIAL – A business which conducts egg hatching, typically of fish and poultry, and which does not conduct retail sales as part of its business

HAZARDOUS WASTE – A waste with properties that make it dangerous or potentially harmful to human health or the environment.

HAZARDOUS WASTE LANDFILL/FACILITY – All structures, other appurtenances, and improvements on the land used for treating, storing, or disposing of hazardous waste, including all operations or storage areas, diked overflow, or emergency spillway areas. A hazardous waste disposal facility may consist of several treatment, storage, or disposal operational units; it includes all areas where hazardous waste may be received, stored, handled, or processed.

HEALTH AND FITNESS CENTER – A facility which provides exercise and wellness opportunities for the general public.

HEALTH CENTER, PUBLIC - A facility primarily utilized by a health unit for providing public health services including related facilities such as laboratories, clinics and administrative offices operated in connection therewith.

HEIGHT, MAXIMUM - Maximum height is measured from grade level to the highest point of the structure.

HELIPORT - A place for helicopters to land and take off.

HOME OCCUPATION – Any activity performed for monetary gain in or directed from a dwelling unit by one (1) or more residents of that dwelling unit which is located in a residential zone or on a property with a dwelling unit as its primary use, provided that such activity meets the requirements set forth in Chapter 3, Specific Use Requirements and Performance Standards, Section 3.1, Home Occupations.

HOSPITAL - An institution licensed by the State Department of Health to provide health services for the sick or injured, and which may include related facilities such as laboratories, out-patient departments, training facilities, central service facilities, and staff offices which are an integral part of the facility; provided such institution is operated by, or treatment is given under direct supervision of a licensed physician. Types of hospitals include general, mental, chronic disease and allied special hospitals such as cardiac, contagious disease, maternity, orthopedic, cancer, and the like.

HOTEL - A commercial building or buildings which, for compensation, offer transient lodging to the public consisting of a bedroom, bathroom and closet space, often times including a work area or small meeting room. The facility may provide additional services, such as a restaurant, lounge, meeting room(s), convention room(s) and/or common recreation facilities. A hotel offers short-term rentals which last less than 30 days. The majority of rooms have access directly to a hallway. Use as an apartment or other type dwelling unit is prohibited.

HUMANE – An action which minimizes the infliction of pain and discomfort and is characterized by compassion, kindness and respect.

□

IMPROVEMENT - Any alteration to the land or other physical constructions associated with subdivision and building site development.

IMPROVEMENT LOCATION PERMIT – A permit issued for zoning and land use compliance verification purposes.

IMPROVEMENT, PUBLIC - Any drainage ditch, roadway, sidewalk, curb, tree, lawn, off-street parking area, main, or other facility for which the local or state government may ultimately assume the responsibility for maintenance and/or operation, or which may affect an improvement for which local or state government responsibility is established. All such improvements shall require performance guarantee.

IMPROVEMENT, TEMPORARY - Improvements built and maintained by a sub divider during construction of the subdivision and which may become permanent prior to release of the performance guarantee.

INCINERATOR - A furnace or a container for burning waste materials.

INDIVIDUAL SEWAGE DISPOSAL SYSTEM - A septic tank, seepage tile, sewage disposal system, or any other approved sewage treatment device designed for use in a limited area as approved by the White County Health Department.

INDUSTRIAL PARK - A planned, coordinated development of a tract of land with two (2) or more separate industrial buildings. Such development is planned, designed, constructed, and managed on an integrated and coordinated basis with special attention given to on-site vehicular circulation, parking, utility needs, building design, orientation and open space.

INDUSTRIAL USE - A use involving the manufacture, procession, assembly, or storage of equipment, raw materials, or manufactured products which require an industrial zoning classification of I-1 or I-2 as stipulated by Appendix A: Official Schedule of Uses.

INDUSTRIAL WASTE FACILITY – A facility used for the storage, transportation, reclamation or disposal of any waste classified as hazardous or toxic by the United States Environmental Protection Agency.

INDUSTRIALIZED RESIDENTIAL STRUCTURE – See Modular Home.

INFORMATION CENTER, VISITOR/TOURIST – A physical location, often simply called an “Information Center”, that provides visitors and tourists with information, maps, flyers, brochures or other similar materials for the purposes of advancing local places of interest or businesses which provide unique services or products which tourists or visitors might find desirable. Identification and information on lodging, camp sites, landmarks and parks are commonly available. Guided tours are often coordinated at these locations and the sites frequently use film or other electronic media formats to present the community and its unique offerings. Educational exhibits and artifact displays are common.

INFRASTRUCTURE - The services and facilities necessary in a community, including but not limited to sewers, water systems, streets, utilities and drainage services.

INGRESS - Access or entry point.

INSTITUTION - Any facility maintained or conducted by a group of persons, a firm, association, non-profit entity, corporation, or government body (i.e. buildings and land designed to aid individuals in need of mental, therapeutic and rehabilitative counseling or buildings and land designed to aid individuals in educational, religious, charitable or other such pursuits).

INTEGRATED CENTER - One or more buildings occupying a site under one ownership or management, containing a number of individual, unrelated and separately operated uses each with their own outside entrance opening to the outdoors or a common concourse. The building or buildings of an integrated center share common site facilities and services such as driveway entrances and exits, parking areas, truck loading, maintenance, sewer and water utilities and similar common facilities and services. A building on an out lot, which is physically separated from the other uses in an integrated center, by curbs and/or landscaping, and which contains its full requirement of parking, but which shares

driveway entrances and exits with other uses, is not part of that integrated center. An office building is not an integrated center. Shopping Centers, Malls, Shopping Malls, Outlets Malls and Strip Malls are retail types of Integrated Centers

INTERESTED PERSON - Someone having an interest in land affected by a given zoning decision as determined by the written rules of either the Area Plan Commission or the Board of Zoning Appeals.

INTERNET SELLING ESTABLISHMENT/E-BAY STORE – A business which purchases items from businesses and/or individuals and/or accepts consignment of items (either physically or not) and sells them through marketing channels available on the internet as their primary function. There may or may not be on-site retail operations. There will normally be stocking and storage of merchandise available for sale.

J

JAIL – A place for the confinement of persons in lawful detention, especially persons awaiting trial under local jurisdiction.

JUNKYARD - Any place at which personal property is or may be salvaged for reuse, resale or reduction or similar disposition and is owned, possessed, collected, accumulated, dismantled, or assorted. Including but not limited to, used or salvaged base metal or metals, their compounds or combinations, used or salvaged rope, bags, paper, rags, glass, rubber, lumber, millwork, brick and similar property except animal matter; and used motor vehicles, machinery or equipment which is used, owned or possessed for the purpose of wrecking or salvaging parts there from.

K

KENNEL, COMMERCIAL – An establishment whose primary purpose is to breed, board or train domestic animals not owned by the owner or occupant of the property.

KENNEL, PRIVATE - Any lot or premises where the care of six (6) or more domestic animals over six (6) months of age belonging to the owner of the principal use, are kept for purposes of show, hunting, or personal enjoyment as pets.

L

LABORATORY, COMMERCIAL – A facility devoted to experimental study, testing or analysis. Manufacturing, assembly or packaging of products shall not be conducted within this facility.

LABORATORY, MEDICAL OR DENTAL - A facility for scientific laboratory analysis of medical or dental resources. The scientific analysis is generally performed for an outside customer. This category includes medical or veterinary laboratories for the analysis of blood, tissue, or other human medical or animal products. Forensic laboratories for analysis of evidence in support of law enforcement agencies would also be included in this category.

LABORATORY, RESEARCH ACTIVITY AND TESTING - Research, development and testing related to such fields as chemicals, pharmaceutical, medical, electrical, transportation and engineering. All research, testing and development, whether conducted within or outside of buildings shall create no noise, smoke, glare, vibration or odor which can be detected outside of the buildings or property line A research and testing laboratory shall mean a building in which scientific research, investigation, testing or experimentation is conducted, but not including the manufacturing or sale of products, except as incidental and accessory to the main purpose of the laboratory.

LAND USE AMENITY - Incidental structures such as, but not limited to, gazebos, picnic tables, benches, patio furniture, decks, pergolas or other similar structures used to increase the function and desirability of a principal use and not included elsewhere.

LANDFILL - The burial of non-hazardous, non-radioactive and non-medical farm, residential, institutional, commercial, or industrial waste, usually after the waste has been compacted.

LANDFILL, SANITARY - An engineered land burial facility for the disposal of solid waste which is so located, designed, constructed, and operated to contain and isolate the solid waste so that it does not pose a substantial present or potential hazard to human health or the environment.

LANDOWNER - The legal or beneficial owner or owners of land.

LANDOWNER, NON-PARTICIPATING (See “NON-PARTICIPATING LANDOWNER”)

LANDOWNER, PARTICIPATING (See “PARTICIPATING LANDOWNER”)

LANDSCAPE CONTRACTOR - Any person, firm, association, syndicate, partnership, realtor or corporation engaged in the business of accepting orders or contracts, either as a general contractor or subcontractor for the planning, design and installation of landscaping for uses. A landscape contractor may provide a retail establishment for the sale of products used for landscaping or yard decorating or home decorating purposes in conjunction with their landscape services.

LANDSCAPING – Any act whose purpose is to modify the visible features of an area of land.

LAUNDRY FACILITY, SELF-SERVICE – A facility where patrons wash, dry, or dry clean clothing or other fabrics in machines operated by the patron.

LAUNDRY OR DRY-CLEANING FACILITY - An establishment or business maintained for the pickup and delivery of dry cleaning and/or laundry with or without the maintenance or operation of any laundry or dry-cleaning equipment or machinery on the premises.

LAYDOWN YARD, TEMPORARY – An outside area used to support construction activity where tools, materials, equipment, parking, storage units, construction trailers or other similar items are temporarily stored or placed for a period of 12 months or less.

LAYDOWN YARD, PERMANENT - An outside area used to support construction activity where tools, materials, equipment, parking, storage units, construction trailers or other similar items are temporarily stored or placed for a period of more than 12 months.

LEASE LINE - Any perimeter boundary line of an area which is a portion of a legal parcel, lot or tract of land, which area is leased to a third party and which boundaries are defined by a legal instrument.

LIBRARY – A place in which literary, musical, artistic or reference materials (such as books, manuscripts, recordings, films, etc.) are kept for use, but generally not for sale.

LICENSE TO ENTER - A right held by a public or private utility or government entity for temporary access on privately owned property to perform maintenance or upgrades to utility infra-structure or road/street bordering amenities.

LIVESTOCK - Generally accepted outdoor farm animals (i.e., cows, goats, horses, pigs, barnyard fowl, etc.) or any animal that is commonly used as a protein source. Livestock does not include domestic animals..

LIVING SPACE - That portion of the floor area constructed, completed and usable for living purposes with normal living facilities which includes sleeping, dining, cooking, working, entertainment, common space linking rooms, areas for personal hygiene or combination thereof. Floor area or portion thereof used only for storage purposes and not equipped for the facilities mentioned above shall not be considered living space. No area in an attached garage shall be considered living space (for the purpose of meeting minimum living space requirements)

LOADING SPACES/BERTHS - The off-street area required for the receipt or distribution by vehicles of material or merchandise.

LOT - A single recorded tract or plot, which is the smallest unit of a residential, commercial or industrial subdivision or other parcel of land. A lot serves as a unit for the purpose, whether immediate or future, of transfer of ownership, or lease. This also includes an area of land created by a subdivision in accordance with this Ordinance or any prior subdivision ordinance.

LOT AREA – The area of the horizontal plane of a lot bounded by the vertical planes of the front, side and rear lot lines. Easements are considered to be part of the lot area. The lot area is exclusive of right-of-way and may not be covered by water.

LOT, CORNER – A lot which has street fronts on two or more adjoining lot lines.

ILLUSTRATION OF THE BASIC TYPES OF LOTS

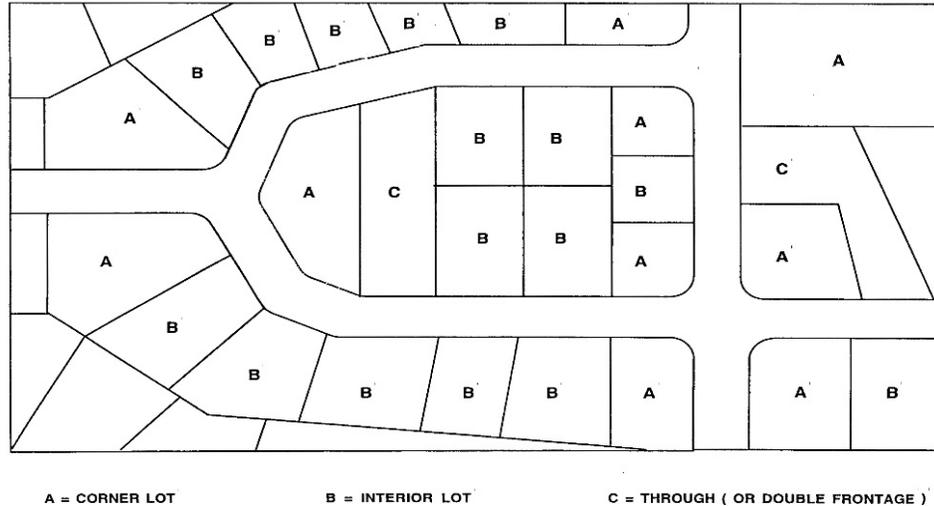

LOT COVERAGE - The total ground area of a lot usually expressed as a percentage of the lot area that is covered, occupied or enclosed by principal and accessory buildings and structures.

LOT, DEPTH OF - The mean horizontal distance between the front lot line and the rear lot line of a lot, measured in the general direction of the side lot line.

LOT, FLAG - A lot not fronting or abutting a public roadway and where access to the public roadway is limited to a narrow private right-of-way.

LOT FRONTAGE - The front of a lot shall be construed to be the portion nearest the street right-of-way. For the purposes of determining yard requirements on corner lots and through lots, all sides of a lot adjacent to street right-of-way shall be considered frontage, and yards shall be provided under "yards" in this Section.

LOT, INTERIOR - A lot other than a corner lot or a through lot.

LOT LINE, FRONT- A line separating a lot from a street. Any lot line, which abuts a street, shall be considered a front lot line; provided, however, for lots located in a lake or river area, the only front lot lines for the lot shall be the lot lines marking the boundary between the lot and the lake or river area. Lake or river area shall be determined at the discretion of the Executive Director.

LOT LINE, OPPOSITE – The side property line on the opposite side of the dwelling from the zero lot line.

LOT LINE, REAR - A lot line which is opposite and most distant from the front lot line and, in the case of an irregular or triangular-shaped lot, a line within the lot, parallel to and at the maximum distance from the front lot line.

LOT LINE, SIDE - Any lot boundary line not a front lot line or a rear lot line.

LOT, MINIMUM AREA OF - The smallest lot area established by this Ordinance on which a use or structure may be located in a particular district, and which does not include any street right-of-way.

LOT, NONCONFORMING - A lot, the area, dimension or location of which was lawful prior to the adoption, revision or amendment of this zoning Ordinance but which fails by reason of the adoption, revision or amendment to conform to the present requirement of the zoning district.

LOT OF RECORD - A lot which is part of a subdivision, the map of which has been recorded in the Office of the County Recorder of White County, Indiana; or a parcel of land, the deed to which has been recorded in the Office of the County Recorder of White County, Indiana, prior to the date of passage of this Section of the Ordinance.

LOT, SALES - Premises on which new or used passenger cars, recreational vehicles, boats, commercial vehicles, farm implements, trailers or other vehicles, or manufactured homes are displayed in the open for sale or trade. All vehicles must be in operable condition.

LOT, THROUGH (DOUBLE FRONTAGE) – A lot which has more than one street front on opposite ends of the parcel.

LOT WIDTH - The dimension of a lot, measured between side lot lines on the building line.

M

MANEUVERING AISLE - A maneuvering space, which serves two or more parking spaces, such as the area between two rows of parking spaces and/or the driveway leading to those spaces.

MANEUVERING SPACE - An open space in a parking area, which is immediately adjacent to a parking space; is used for and/or is necessary for turning, backing or driving forward a motor vehicle into said parking space; but is not used for the parking or storage of motor vehicles.

MANUFACTURED HOME – As defined in IC 9-13-2-96, a manufactured home is assembled in a factory; bears a seal certifying that it was built in compliance with the federal manufactured housing construction and safety standards law (42 U.S.C. 5401 et seq.); is designed to be transported from the factory to another site in one (1) or more units; is suitable for use as a dwelling in any season; and is more than thirty-five (35) feet long. All manufactured homes shall be in compliance with the federal manufactured Housing Construction and Safety Standards Law of 1974 (42 U.S.C. 5401 et seq).

MANUFACTURED HOME PARK OR SUBDIVISION – A manufactured home park or subdivision for which the construction of facilities for servicing the lots on which the manufactured homes are to be affixed (including at a minimum, the installation of utilities, the construction of streets, and either final site grading or the pouring of concrete pads) is completed on or after the effective date of this ordinance.

MANUFACTURED HOME PARK OR SUBDIVISION, EXISTING – A manufactured home park or subdivision for which the construction of facilities for servicing the lots upon which the manufactured homes are to be affixed (at a minimum, the installation of utilities, the construction of streets, and either final site grading or the pouring of concrete pads) is completed before the effective date of this ordinance.

MANUFACTURED HOME PARK OR SUBDIVISION, EXPANSION – The preparation of additional sites by the construction of new facilities for servicing the lots on which manufacturing homes are to be affixed (including the installation of utilities, the construction of streets, and either final site grading or the pouring of concrete pads).

MANUFACTURED HOME SALES – The sale of dwelling units designed and built in a factory and installed as a permanent residence, which bears a seal certifying that it was built in compliance with the National Manufactured Home Construction and Safety Standards Act (1974 U.S.C. 5401 et seq.).

MANUFACTURED HOME, SECTION - A unit of a manufactured home at least ten (10) feet in width and thirty (30) feet in length.

MANUFACTURED/MOBILE HOME DWELLING – A Type II Manufactured or Mobile Home which is used in accordance to Subsection 3.4.1 of the White County Indiana Zoning and Subdivision Control Ordinances.

MANUFACTURED/MOBILE HOME OFFICE – A Manufactured or Mobile Home which is used in accordance to Subsection 4.4.1 C. of the White County Indiana Zoning and Subdivision Control Ordinances.

MANUFACTURED/MOBILE HOME OFFICE, PERMANENT – A manufactured or mobile home utilized as a permanent office by a public or private enterprise.

MANUFACTURED HOUSING CONSTRUCTION AND SAFETY STANDARDS CODES -- Title VI of the 1974 Housing and Community Development Act (42 U.S.C 5401 et sequential), as amended (previously known as the federal Mobile Home Construction and Safety Act), rules and regulations adopted there under (including information supplied by the home manufacturer, which has been stamped and approved by a Design Approval Primary Inspection Agency, an agent of the U.S. Department of Housing and Urban Development pursuant to HUD rules), and regulations and interpretations of said code by the Indiana Administrative Building Council; all of which became effective for mobile/manufactured home construction on June 15, 1976.

MANUFACTURING – The process of making, assembling, adding improvements to, or fabricating raw materials by hand, machinery or the combination thereof into finished or semi-finished parts or products.

MANUFACTURING, EXTRACTIVE NON-URBAN - Any mining, quarrying, processing, storing, separating, cleaning or marketing of any material natural resource, excluding gas and oil, outside an urban area.

MANUFACTURING, EXTRACTIVE URBAN – Any mining, quarrying, processing, storing, separating, cleaning or marketing of any material natural resource, excluding gas and oil, within an urban area.

MANUFACTURING, HEAVY - A use engaged in the processing and manufacturing of materials or products predominately from extracted or raw materials, or a use engaged in storage of, or manufacturing processes using flammable or explosive materials, or storage or manufacturing processes that potentially involve hazardous or commonly recognized offensive conditions which would generate objectionable or hazardous elements such as: heat, smoke, odor, vibration, water pollution, electromagnetic disturbances, radiation or dust. Such uses will often have outside storage of materials, equipment and products and will commonly have on-site OEM or retail sales staff and facilities and/or showroom to support the promotion of their products and services.

MANUFACTURING, LIGHT - Manufacturing or other industrial uses which are controlled operations; relatively clean, quiet and free of objectionable or hazardous elements such as smoke, noise, odor, or dust; operating and storing entirely within enclosed structures; and generating little industrial traffic and no nuisance. Such uses will commonly have on-site OEM or retail sales staff and facilities and/or showroom to support the promotion of their products and services.

MARINA – Waterfront establishments whose business is offering the sale or rental of boats and marine sporting equipment and the servicing, repair, or storage of same. Such establishments may also provide travel lift services, slip rental, gasoline, sanitary pump out service and food, drink and transient lodging accommodations.

MASSAGE – The rubbing or kneading of muscles and joints of the body with hands, arms, elbows or feet for the purpose of relieving stress, increasing circulation, relieving muscle and/or joint stiffness and/or pain or relaxing muscles without the result of sexual arousal or the purpose of sexual stimulation of any kind. The process sometimes includes the use of mechanical or electrical devices and may utilize supplementary aids such as oils, lotions, ointments, liniments, creams, rubbing alcohol or other similar preparatory products.

MASSAGE PARLOR – An establishment whose primary purpose is to provide massage services as defined herein and whose employees are state licensed to provide such services. The establishment must generate at least 75% of its revenue from massage services.

MECHANICAL RIDES OR ATTRACTIONS – A device ridden or operated for amusement or excitement driven by some type of machine or tool.

MEDICAL CLINIC – An establishment where patients, who are not lodged over-night, are admitted for examination, testing, and/or treatment by a group of physicians, dentists, optometrists, chiropractors or other health care professionals.

MEDICAL EMERGENCY/IMMEDIATE CARE FACILITY - A facility for the examination and outpatient treatment of “walk-in” human patients, which may be open 24 hours per day.

MEDICAL, MENTAL HEALTH FACILITY (OR PSYCHIATRIC HOSPITAL) - A facility or institution for diagnosing, treating, caring for, or counseling people requiring mental health services in confinement.

MEDICAL OFFICE – An entity or establishment where patients, who are not lodged over-night, are admitted for examination, testing, and/or treatment by a single physician, dentist, optometrist, chiropractor or other health care professional.

METAL FORGING PLANT – See Foundry Plant.

METEOROLOGICAL TOWER – Towers which are erected primarily to measure wind speed and direction plus other data, excluding towers and equipment used by airports, the Indiana Department of Transportation, or other similar applications to monitor weather conditions.

METEOROLOGICAL TOWER, OPERATIONAL SUPPORT – Towers which are erected primarily to measure wind speed and direction plus other data in support of an operating WECS, excluding towers and equipment used by airports, the Indiana Department of Transportation, or other similar applications to monitor weather conditions.

MINERAL EXTRACTION - Mining or quarrying; and removal of earth materials.

MINIATURE GOLF FACILITY - Typically a theme-oriented recreational facility, usually comprised of nine or 18 putting greens, each with a “cup” or “hole”, where patrons in groups of one to four pay a fee to move in consecutive order from the first hole to the last.

MINI-BARN – See the definition for SHED.

MIXED USE - A single building containing more than one (1) type of land use or a single development of more than one (1) building and use, where the different types of land uses are in close proximity, planned as a unified complementary whole, and functionally integrated to the use of shared vehicular and pedestrian access and parking areas.

MOBILE HOME - Any vehicle more than thirty-two (32) feet in length designed by the manufacturer or maker with hitch and undercarriage to permit its being used as a conveyance upon public streets and highways and so designed, constructed or reconstructed as will permit the vehicle to be used as a dwelling and not qualifying under the definition of manufactured home or recreational vehicle.

MOBILE HOME, OFFICE – A mobile home used temporarily during a period of construction and development.

MODEL HOME OR APARTMENT- A dwelling unit used temporarily for display purposes which typifies the type of units that will be constructed in the subdivision in which the dwelling unit is located, and may contain a temporary sales office for the residential development in which the dwelling unit is located.

MOBILE HOME PARK - An area of land upon which two or more Mobile Homes are harbored for the purpose of being occupied either free charge or in consideration of the payment of rental for the Mobile Home or the site upon which it rests; and within which area a Mobile Home may be supported either by its wheels or by a foundation of any sort.

MOBILE HOME SPACE -- A plot of ground within a mobile home park designated for the accommodation of one mobile home.

MOBILE HOME STAND -- That part of an individual mobile home space which has been reserved for the placement of the mobile home, appurtenant structures, or additions.

MOBILE HOME SUBDIVISION – A “subdivision” as defined by the state Subdivision Control Act, being Act 288 of the Public Acts of 1967, as amended, which has been expressly established for the sole purpose of selling lots on which mobile homes may be used and occupied for residential purposes, and which has been established in full compliance with all applicable provisions of the aforementioned Act and of all other applicable state and county regulations.

MODULAR HOME - A factory-built home, other than a manufactured home, which meets all of the following requirements: is designed only for erection or installation on a site-built permanent foundation; is not designed to be moved once so erected or installed; is designed and manufactured to comply with a nationally recognized model building code or an equivalent local code, or with a state or local modular building code recognized as generally equivalent to building codes for site-built housing; or to the manufacturer’s knowledge, is not intended to be used other than on a site-built permanent foundation.

MONUMENT, SURVEY - Any permanent marker either of stone, concrete, galvanized iron pipe, or iron or steel rods, used to identify the boundary lines of any tract, parcel, lot or street lines.

MONUMENT WORKS AND STONE CUTTING – A sculpture created by using power tools such as compressed-air chisels, abrasive spinners and angle grinders on stone from the earth.

MOTEL - A commercial building or buildings devoted to the provision of sleeping accommodations for automobile transients consisting of a bedroom, bathroom, closet space, and convenient access to a parking space. Motels may include other accessory uses such as a restaurant, lounge, swimming pool, meeting room and the like. A motel offers short-term rentals which last less than 30 days. The majority of rooms have access directly to the outdoors with the facility designed for motorists. Use as an apartment or other type dwelling unit is prohibited.

MOTOR VEHICLE - An automobile, truck, motorcycle and any other vehicle propelled or driven otherwise than by muscular power, but does not include the cars of electric or steam railways, or other motor vehicles running only upon rails, or a motorized snow vehicle, traction engine, farm tractor, self-propelled implement of husbandry or road building machine.

MOTOR VEHICLE, INOPERABLE - A vehicle from which the engine, transmission, or differential has been removed or that is otherwise partially dismantled or inoperable and left on public property, or; a vehicle that is at least three (3) model years old, is mechanically inoperable, and is left on private property continuously in a location visible from public property for more than twenty (20) days.

MOTORCYCLE SALES - The use of any building or portion thereof, or other premises or portion thereof, for the display, sale, rental, or lease of new motorcycles, or used motorcycles as an ancillary use of a zoning lot, and any warranty repair work and other repair service conducted as an accessory use.

MUSEUM/GALLERY – A building in which objects of historical, scientific, artistic or cultural interest are stored and exhibited and which may include retail, food service or other offerings complimentary to promoting the museum activities. In no case may the museum floor space be less than 50% of the total floor space of the facility/facilities including accessory structures.

N

NAMEPLATE: A flat piece of wood, plastic or metal used solely for the purpose of identifying the name of a person, company or activity (such as occupation) or to identify a particular building. Name plates may be no larger than three (3) square feet. Larger nameplates, if warranted due to the number of name characters or which are remotely located (such as at the top of a building or on a building a significant distance from a typical, public viewing point, may be installed upon written authorization from the Executive Director or upon approval from the Area Board of Zoning Appeals.

NATURAL RESOURCES, DEPARTMENT OF -- The Department of Natural Resources of the State of Indiana.

NEIGHBORHOOD FACILITY – A building utilized for multiple purposes and created for the general benefit and welfare of the local community. This facility will utilize portions of the facility for multiple uses such as office rentals, museum type exhibitions, theatrical and musical performances, recreational purposes, banquet facilities and as a location for minor conventions, small trade shows, community meetings, social or cultural events, local festivities such as parades, festivals, carnivals, bazaars, etc. These locations would also be suitable for YMCA, YWCA, Boy Scout or Girl Scout facilities.

NEON - Irregularly bent or shaped glass tubing containing gaseous neon, which glows when an electrical current is applied.

NET-METERING - Net-metered customers are credited for net excess generation, wherein no cash is given to the owner of the wind turbine.

NEWSPAPER PUBLISHING - The trade, profession, or activity of preparing and producing news material in printed or electronic form for distribution to the public

NEWSPAPER STAND - A temporary structure, manned by a vendor that sells newspapers, magazines, other periodicals. Can also include a permanent stand where money is deposited into a machine to receive a paper.

NON-PARTICIPATING LANDOWNER – A person(s) or entity who has NOT entered into any final contractual agreement with a Wind Energy Conversion System (WECS) or Commercial Solar Energy System (CES) company, entity or person(s) (i) for the purposes of developing a WECS and/or CES Project on or near such person(s) or entity's land and/or (ii) to receive certain economic benefits to accrue from the operation of the WECS or CES Project.

NON-PARTICIPATING PROPERTY – A lot or parcel of real property that is not owned by a project owner and, with respect to which:

- 1) the project owner does not seek to install or locate one (1) or more CSE systems or other facilities related to a CSE system project (including power lines, temporary or permanent access roads, or other temporary or permanent infrastructure); or,
- 2) the owner of the property does not consent to having one (1) or more CSE systems or other facilities related to a CSE system project (including power lines, temporary or permanent access roads, or other temporary or permanent infrastructure) installed or located; or, to otherwise enter into a lease or any other agreement with the project owner of use of all or part of the property in connection to a CSE systems project.

NON-PROFIT/CHARITABLE ORGANIZATION – A tax-exempt organization which uses money earned from fundraising activities or donations to further a charitable, scientific, religious, literary, educational or public safety purpose or other activity serving the public interest or common good.

NOXIOUS MATTER OR MATERIALS -- That which is capable of causing injury to living organisms by chemical reaction or is capable of causing detrimental effects upon the physical or economic well-being of individuals.

NURSERY, HORTICULTURE – Land, building(s), structure(s), or any combination thereof used for the storage, cultivation, transplanting of live trees, shrubs, flowers and other plants including products used for gardening or landscaping. The business may operate as a wholesale or retail business or both.

NURSING HOME – Any institution, whether operated for profit or not, including a place operated by a county or municipality, which undertakes through its ownership or management to provide for a period exceeding 24 hours, nursing care, personal care, or custodial care for three or more persons not related to the owner or manager by blood or marriage, who by reason of illness, physical infirmity, or advanced age require such services, but, in contradistinction to a hospital, does not include any place providing care or treatment primarily for the acutely ill.



OCCUPANCY - The residing of an individual overnight in a dwelling unit, or the installation, storage or use of equipment, merchandise or machinery on the premises or in any public, commercial or industrial building and/or the use of land, building or structures. A change in occupancy is not intended to include a change of tenants or proprietors.

OCCUPANCY PERMIT - A required permit allowing occupancy of a building or structure after it has been determined that the building or structure meets all the requirements of applicable Ordinances.

OFFICE BUILDING - A building in which the majority of gross leasable area is devoted to conducting a mix use of professional, institutional, government or administrative services or affairs and compartmentalized in a manner so that each such activity or entity has public entrances in the interior of the building

OFFICE RESEARCH PARK - A large tract of land that has been planned, developed and operated as an integrated facility for a number of separate office buildings and supporting ancillary uses with special attention to circulation, parking, utility needs, aesthetics, and compatibility.

OFF-SITE (OFF-PREMISES) - Outside the limits of the area encompassed by the tract area or the parcel of record on which the activity is conducted.

ONE AND TWO-FAMILY DWELLING ORDINANCE, INDIANA - The nationally recognized model building Ordinance adopted by the Indiana Department of Fire Prevention and Building Safety as mandated by Public Law 360, Act of 1971, and which includes those supplements and amendments promulgated by this agency.

ON-SITE - Located inside the property lines of the parcel in question.

OPEN SPACE - The total horizontal area of a lot excluding the building area but including parking areas and recreational areas, provided, however, in Residential Districts, said open space may include the usable roof area within the project which has been improved for outdoor use of occupants, plus one-half of that space, such as balconies, which may be open on its sides but not open above to the sky.

OPEN SPACE, COMMON - Land within or related to a development, not individually owned or dedicated for public use, that is designed and intended for the common use or enjoyment of the residents of the development and may include such complementary structures and improvements as necessary and appropriate.

ORCHARD/VINEYARD - A group of fruit or nut trees, either small and diverse and grown for home use, or large and uniform (i.e., of one variety) and cultivated for revenue. Such a collection must be planted, managed, and renewed by the householder or farmer and should not be confused with a naturally occurring grove. Orchards include vineyards.

ORDINANCE – A law or regulation set forth and adopted by a governmental authority, usually a city or county.

OUTDOOR LIGHT (FIXTURE) - A light fixture located outside or intended to be viewed from the outside.

OUTDOOR STORAGE - The keeping, in an unroofed area, of any goods, material, merchandise, or vehicles in the same place for more than twenty-four (24) hours.

OVERLAY DISTRICT – A district established by ordinance to prescribe special regulations to be applied to a site in combination with the underlying or base district.

OWNER - A, person, firm, association, syndicate, partnership, corporation, or any other legal entity recorded as such on official records, and including a duly authorized agent or notary, a purchaser, a devisee, judiciary, and person having a vested or contingent interest in the property in question as long as written proof of such can be produced upon request.

P

PARCEL – Any legally described piece of land that may or may not be subdivided. Also known as a tract of land. This also includes any area of land created by an exempt division of land as provided by this Ordinance.

PARK, PRIVATE – A facility or location, owned by one or more individuals and/or businesses designed to service the owner’s recreational needs, used at the discretion of the owner and may or may not be open to the general public.

PARK, PUBLIC – A noncommercial, not-for-profit facility designed to serve the recreation needs of the residents of White County or any of its municipalities. Such facilities include subdivision recreation facilities, community parks, regional parks and special use facilities. Such facilities may also include but shall not be limited to school and religious institution ball fields, playgrounds, tracks or other outside activity areas; if they meet the above definition. Commercial amusement facilities such as water slides, go-cart tracks and miniature golf courses shall not be considered parks.

PARKING, EXCESS - An area of ground committed to accommodating peak capacity parking requirements which occur on a sporadic basis. These areas are only allowed in unincorporated areas of the County and outside the defined boundaries of Idaville and Buffalo. These areas are not required to be paved. They may be grass or gravel covered. Each excess parking space requires the same space and aisle measurements as a right-angle parking space as defined in Table 8.2 of Chapter 8: Parking and Loading Standards, of the White County Indiana Zoning Control Ordinance.

PARKING LOT - An off-street, ground level, unenclosed area of land intended to be used for periodic storage of operable passenger automobiles, commercial vehicles, trailers or other units designed for use on public or private roads. A parking lot may be available to the public as an accommodation to clients or customers, whether for free of charge or for compensation.

PARKING LOT, SPECIAL EVENT – An off-street, ground level, open area to be used temporarily for the storage of passenger vehicles during a special event.

PARKING SPACE - A space designated for the temporary parking of a motor vehicle, trailer or other unit designed for use on public or private roads.

PARKING STRUCTURE: A structure or portion thereof, either privately or publicly owned, composed of one or more levels or floors used exclusively for the parking or storage of Class I and Class II motor vehicles. A parking structure may be totally below grade, as in an underground parking garage, or either partially or totally above grade with those levels being either open or enclosed.

PARTICIPATING LANDOWNER – A person(s) who owns land and has entered into a fully executed contractual agreement associated with a renewable energy project (commercial wind power project or commercial solar energy system project).

PARTICULATE MATTER - Finely divided liquid or solid material, which is discharged and carried along in the air. This shall not include water droplets, commonly called steam.

PASSENGER VEHICLE – Every vehicle, except motorcycles, designed for carrying twelve (12) passengers or less and used for the transportation of persons, including all vehicles within Classes 1 and 2, as categorized by the Motor Vehicle Manufacturers Association of the United States, Inc.

PATIO –A paved, concrete, stone, composite material or concrete block outdoor space or inner courtyard that is used for dining, relaxation or recreation which may or may not be adjacent to a building.

PEDDLER – An individual, company or other entity which sells or solicits door-to-door to residences. Peddlers operate under a transient merchant’s peddler’s permit. For other temporary sales type activities see Street Vendor.

PENNANT – Any lightweight plastic, fabric, or other material, whether or not containing a message of any kind, suspended from a rope, wire, or string, usually in series, designed to move in the wind.

PERFORMANCE GUARANTEE – An amount of money or other negotiable security paid by the applicant or the applicant’s surety to White County, which guarantees that the applicant will perform all actions required by White County regarding an approved plat, and provides that if the applicant defaults and fails to comply with the provisions of any approved plat, the applicant or the applicant’s surety will pay damages up to the limit of the performance guarantee bond, or the surety will itself complete the requirements of the approved plat.

PERFORMANCE STANDARDS – A set of criteria or limits relating to nuisance elements that a particular use or process may not exceed.

PERIMETER RETAINING WALL – A perimeter non-load-bearing structural system completely enclosing the space between the floor joists of a manufactured or mobile home and the ground.

PERMANENT FOUNDATION – A structural system for transposing to the earth at a depth below the established frost line without exceeding the safe bearing capacity of the supporting soil.

PERMITTED STRUCTURE OR USE – Any structure authorized or permitted alone or in conjunction with another structure in a specific district and subject to the limitations of the regulations of such district.

PERMITTED USE - Any use authorized or permitted alone or in conjunction with another use in a specific district and subject to the limitations of the regulations of such use district.

PERSON - A corporation, firm, partnership, association, cooperative organization or any other group acting as a unit, as well as a natural person.

PERSONAL/PROFESSIONAL SERVICES – Any business entity or enterprise whose primary purpose is to offer service(s) to the general public excluding medical or any personal or professional service type listed individually in Appendix A, Official Schedule of Uses.

PET GROOMING, DOMESTIC (PET SPA) - A facility which provides pet grooming services such as, but not limited to, teeth cleaning, hair cutting, shampoos, nail clipping and such similar type activities. These short-term facilities are not allowed to accommodate overnight pet stays or utilize outdoor kennels (a fenced yard is permissible). The operating hours of this facility would be allowed between 6:00 am and 8:00 pm.

PLAN COMMISSION – The White County Area Plan Commission.

PLAN, CONCEPT – Written and graphic documents submitted for subdivision plats, development plans, Planned Unit Developments, annexation, and rezoning petitions that indicate in a conceptual form the proposed land uses and their overall impact on the subject lot and surrounding area.

PLAN, PRELIMINARY - An initial map of a subdivision of land or development plan that is presented to the proper review authority for preliminary approval

PLANNED UNIT DEVELOPMENT (PUD) - A large-scale unified development meeting the requirements for zoning approval under the provisions of Chapter 6, Planned Unit Development of this Ordinance.

PLAT - A Map or Chart indicating the subdivision or re-subdivision of land, intended to be filed for record.

PLAT, FINAL – The final map of all or a portion of a subdivision or development plan that is presented to the proper review authority for final approval.

PLAT, PRELIMINARY -- The preliminary drawing or drawings, described in these regulations, indicating the proposed manner or layout of the subdivision to be submitted to the Commission for approval.

POLE BARN (POST & FRAME BARN) – A building utilizing a frame system of wood roof trusses connected to treated poles that are anchored into the ground, generally with cement and/or rocks. The system includes structural members such as wall headers, roof pulins and wall girts to support the exterior cladding (siding & roofing). Boards and metal are used for the sides and roof and attached with screws and/or nails.

POLICE STATION – A location that serves as headquarters for police which serves as a place from which police officers are dispatched and to which arrested persons are initially brought.

PORCH - A roofed-over structure, other than a stoop, projecting out from the wall or walls of a main structure which may be open or enclosed but which does not provide facilities for heat or air conditioning.

PORTABLE POTTY aka PORT-a-POT, PORTABLE TOILET, PORTA POTTIE AND PORTA LOOS: A portable structure designed for the receipt of human waste containing a chemical toilet used as a temporary toilet for construction sites, festivals and large gatherings. Any other use for which a Portable Potty is intended is required to obtain a temporary use permit and limited to on-site location for no more than thirty (30) days.

POST OFFICE – A building where the primary purpose is receiving, sorting and distributing United States mail and where various postal materials are sold and where postal services are provided.

PREMISES - A lot or plot of land, including any buildings thereon.

PRINCIPAL STRUCTURE – The primary structure on a property.

PRINCIPAL USE - The primary use to which a property is devoted and as the main purpose for which the property exists.

PRINTING, LITHOGRAPHING, PUBLISHING OR PHOTOGRAPHY ESTABLISHMENTS – A commercial printing operation involving a process that is considered printing, imprinting, reproducing, or duplicating images and using printing methods including but not limited to offset printing, lithography, web offset, flexographic, and screen process printing.

PROPERTY LINE – A line, established by survey, including its vertical extension which: (1) separates real property owned or controlled by another person; and (2) separates real property from the public right-of-way.

PROPERTY, NON-PARTICIPATING (See “NON-PARTICIPATING PROPERTY”)

PUBLIC WAY – An alley, avenue, boulevard, bridge, channel, ditch, easement, expressway, freeway, highway, land, parkway, right-of-way, road, sidewalk, street, subway, tunnel, viaduct, walk or other ways in which the general public or a public entity have a right, or which are dedicated, whether improved or not.

R

RABBIT – A burrowing, gregarious, plant eating mammal with long ears, long hind legs and a short tail. The mammal is in the family Leporidae of the order Lagomorpha.

RACE TRACK – A specially surfaced course upon which races are held.

RADIO, TV, MUSIC STUDIO/STATION – A facility utilized for sound recording and mixing or for the transmission of content, either digital or analog, over terrestrial television or for the transmission of signals through free space by electromagnetic waves with frequencies below visible light.

RAILROAD FACILITIES – The occupation and use of land, buildings, and structures for purposes directly connected with rail transportation of articles, goods, and passengers, including such facilities as tracks, sidings, signal devices and structures, shops and yards for maintenance and storage of rail machinery, loading platforms, and passenger and freight terminals, but excluding freight terminals and yards, and similar facilities, which are maintained and operated by the owning railroad or by a lessee for the purposes auxiliary to rail transportation, or by a lessee for the purposes auxiliary to rail transportation; provided, however, that the operation of such facilities as a hobby or as part of an amusement business shall not be considered a railroad facility.

RAILROAD RIGHT-OF-WAY - A strip of land with tracks and auxiliary facilities for track operation, but not including depots, loading platforms, stations, train sheds, warehouses, car shops, car yards, locomotive shops or water towers.

RAISING AND BREEDING OF NON-FARM FOWL OR ANIMALS, COMMERCIAL - The keeping of domesticated animals which are kept for personal or agricultural use, or raised for sale and profit. Does not include commercial kennels or exceptions made under the area of Micro-Farming.

RECREATION, CAMPGROUND – A primitive and/or improved parcel of land used or intended to be used for temporary occupancy by campers, through the use of recreational vehicles, travel trailers, mobile homes, tents, cabins, or other temporary accommodations.

RECREATION FACILITY, COMMERCIAL - Recreation facilities which are operated by a private entity, individual or otherwise.

RECREATION FACILITY, NON-COMMERCIAL - - Recreation facilities which are operated by a non-profit organization.

RECREATIONAL FACILITY, INDOOR - A place primarily designed and equipped for the conduct of sports and leisure-time activities indoors. Such facility may be either public or private and open only to members or to the general public. Activities may include, but are not limited to swimming pool, tennis, racquetball, basketball, bowling, children's play equipment, weight training, ice-skating, pool/billiards, and roller-skating, etc.

RECREATIONAL FACILITY, OUTDOOR - A place primarily designed and equipped for the conduct of sports and leisure-time activities outdoors. Such facility may be either public or private and open only to members or to the general public in exchange for an admission fee. Activities may include, but are not limited to, golf courses, game courts, swimming facilities, etc.

RECREATIONAL VEHICLE -- A vehicle designed to provide temporary living quarters for travel recreation or camping which is either self-propelled or mounted on or toward by another powered vehicle. The term includes but is not limited to travel trailers, collapsible trailers, truck mounted campers, motor homes, tent trailers and converted buses and trucks. An RV is not a dwelling.

RECREATIONAL VEHICLE PARK - Any lot or parcel of land used or intended to be used for the accommodation of two or more motor homes or other recreational vehicles for recreational use or transient dwelling purposes. There is no minimum required stay in a recreational vehicle park. Uses where unoccupied for sale or lease, or are stored, are not included.

RECREATIONAL VEHICLE SALES – The use of any building, land area, or other premises or portion thereof, for the display, sale, or lease of new recreational vehicles and related accessory uses.

RECREATIONAL VEHICLE STORAGE, OUTDOOR – An outdoor area that is used for the storage of recreational vehicles

RECYCLABLE MATERIAL - Any material that can be converted into a raw material for use in a manufacturing process. Recyclable materials include but are not limited to glass, metal and plastic containers and paper products.

RECYCLING FACILITY - A building or area where recyclable material only is collected, sorted, and processed, prior to shipment for remanufacture into new materials at a separate facility.

RECYCLING SATELLITE, PRIVATE - Portable or permanent collection containers or vehicles utilized for the collection of recyclable materials from the general public and located at sites separate from a Recycling or Solid Waste Transfer Facility. Collection containers or vehicles are periodically emptied or taken to a location where collected materials are incorporated into a facility's recycling or re-utilization processes. The collection units are operated or managed by a private party, organization or institution and do not include on-site recycling containers or vehicles which are utilized by a property owner, tenant or other interested party for the purposes of on-site waste management efforts. These collection units are part of a community recycling effort sponsored and supported by a legislative body and do not include on-site recycling containers or vehicles which are utilized by a property owner, tenant or other interested party for the purposes of their own waste management efforts.

RECYCLING SATELLITE, PUBLIC - Portable or permanent collection containers or vehicles utilized for the collection of recyclable materials from the general public and located at sites separate from a Recycling or Solid Waste Transfer Facility. Collection containers or vehicles are periodically emptied or taken to a Recycling or Solid Waste Transfer Facility where collected materials are incorporated into a facility's recycling processes. These collection units are part of a community recycling effort sponsored and supported by a legislative body and do not include on-site recycling containers or vehicles which are utilized by a property owner, tenant or other interested party for the purposes of on-site waste management efforts.

REFINERY, PETROLEUM - Oil-related industrial activities involving the processing or manufacture of substances such as: asphalt and tar paving mixtures; asphalt and other saturated felts (including shingles); fuels; lubricating oils and greases; paving blocks made of asphalt, creosoted wood, and other compositions of asphalt and tar with other materials; and roofing cements and coatings.

RELIGIOUS INSTITUTION - A building wherein persons regularly assemble for religious worship and which is maintained and controlled by a non-profit religious body organized to sustain public worship, together with all accessory buildings and uses customarily associated with such primary purpose. This includes synagogue, temple, mosque, church or other such place for worship and religious activities. Also included would be accessory facilities utilized to support activities sponsored by the on-site organization.

RENDERING PLANT -- A processing operation where dead animals, supermarket rejects and/or slaughterhouse waste/remains are recycled into products from human food to biodiesel.

RENTAL, SHORT TERM: A rental period of less than 30 days; typically associated with rentals for visitors, transient travelers, tourists, etc..

RESORT - A hotel or motel containing a total of more than three (3) dwelling units and/or guest rooms and which provides outdoor recreational activities that may include golf, horseback riding, swimming pool, shuffleboard, tennis or similar activities. A resort may furnish services customarily furnished by a hotel, including a restaurant, cocktail lounge, and convention facilities. A resort offers short-term rentals which last less than 30 days. Use as an apartment or other type dwelling unit is prohibited.

RESTAURANT - An establishment with or without table service whose principal business is the selling of unpackaged food and beverages to the customer in a ready-to-consume state, in individual servings or in non-disposable containers regardless of whether consumption is on or off the premises.

RESTAURANT, DRIVE THROUGH – A restaurant with a window designed to accommodate automobile traffic.

RESTRICTIVE COVENANTS - Limitations of various kinds of the usage of lots within a subdivision which are proposed by the subdivider, and, in the case of public health, safety and welfare, by the Commission, that are recorded with the plat and run with the land.

RETAIL ESTABLISHMENT: A commercial enterprise that provides goods and/or services in small quantities directly to the consumer, where such goods are available for immediate purchase and removal from the premises by the purchaser.

RETAIL SHOPPING CENTER - A group of commercial establishments planned, constructed, and managed as a total entity with customer and employee parking provided on-site, provision for goods delivery separated from customer access, aesthetic considerations, and protection from the elements.

RETAIL, TEMPORARY – Retail sales conducted out of a location, structure or business not related to the current use of the site and in operation for no longer than 30 consecutive days at a time.

RETAINING WALL – That portion of a wall or structure that holds back soil or rock to prevent down slope movement or erosion and provide support for vertical or near-vertical grade changes.

RETENTION AREA - An area that is designed to capture and hold specific quantities of storm water indefinitely.

RETREAT – A remote location, with or without religious affiliation, where individuals or groups go to withdraw from normal day to day activities for the purposes of achieving greater inner strength, physical improvement or both. Activities such as prayer, meditation, contemplation or intellectual study or activities to rekindle or deepen one's relationship with God may be utilized. This may take place in either an individual or group setting. Various types of exercise, recreational or worship formats may be offered which may be independent of, or in conjunction with, activities designed to reach mental balance and/or enlightenment.

RIGHT-OF-WAY - A public right-of-way that is dedicated or deeded to the public for public use and under the control of a public agency and is a public or private strip of land acquired that allows for the passage of people or goods. Right-of-way includes passage ways such as freeways, streets, bike paths, alleys, walk ways, trails, water lines, sanitary sewers, and/or other public utilities or facilities. Typically, right-of-way is acquired by reservation, dedication, prescription, or condemnation.

RIGHTS-OF-WAY, APPARENT – A prescriptive easement where the boundaries of the easement are established by the public use of travel, excluding the berm, ditch or shoulder. The easement limits are normally identified by the edge of the paved or graveled portion of the easement necessary to accomplish such use.

RIGHTS-OF-WAY, PUBLIC (ROW) - A strip of land that is dedicated or deeded to the public or a governmental entity which provides for the passage of people or goods. Rights-of ways fall within a defined or legally recognized boundary line. Rights-of-ways are generally found in conjunction with freeways, streets, bike paths, alleys, walk ways, trails, bridges, water lines, sanitary sewers and/or other public utility facilities when rights are conveyed by instrument, prescription or condemnation. Rights-of-way do not include land which is subject to a "license to enter" for a public or private utility or government entity.

RINGELMANN NUMBER - The number of the area on the Ringelmann Chart that most nearly matches the light-obscuring capacity of smoke. The Ringelmann Chart is published by the U. S. Bureau of Mines, and it illustrates graduated shades of gray for use in estimating smoke density. Smoke below the density of Ringelmann No. 1 shall be considered no smoke, or Ringelmann "0".

ROAD BUFFER ZONE - That area of land which lies within twenty (20) feet of any apparent rights-of-way and which is not itself a public right-of-way.

ROOF - The cover of any building, including the eaves and similar projections.

ROOFLINE - The outline or contour of the roof of a building; or the profile of a roof.

ROOSTER – An adult male domestic chicken.

ROTOR DIAMETER – The diameter of the circle described by the moving rotor blades

RUMMAGE SALE – See Garage Sale

S

SALE or LEASE - Any immediate or future transfer of ownership, or any possessory interest in land, including contract of sale, lease, devise, intestate succession, or transfer of an interest in a subdivision or part thereof, whether by metes and bounds, deed, contract, plat, map, lease, devise, intestate, succession, or other written instrument.

SAME OWNERSHIP - Ownership by the same person, corporation, firm, entity, partnership, or unincorporated association, or ownership by different corporations, firms, partnership, entities, or unincorporated associations, in which a stockholder, partner, or associate, or a member of his family owns an interest in each corporation, firm, partnership, entity, or unincorporated association.

SAWMILL – A facility where logs or partially processed cants are sawn, split, shaved, stripped, chipped, or otherwise processed to produce wood products, not including the processing of timber for use on the same lot by the owner or resident of that lot.

SCHOOL, HOME - As regulated by IC 20 and seq., the State of Indiana allows for children to be home educated. The law requires that children be in school from 7-17 years of age and that they attend school for 180 days each year

SCHOOL, TRADE OR BUSINESS - A school conducted as a commercial enterprise for teaching business or secretarial skills, instrumental music, dancing, barbering or hair dressing, drafting, and the like; or for teaching industrial or technical arts.

SCRAP METAL YARD - A general industrial use established independent or ancillary to and connected with another general industrial use, which is concerned exclusively in new and salvaged metal pipes, wire, beams, angles, rods, machinery, parts, filings, clippings, and all other metal items of every type, and which acquires the items incidental to its connection with the other general industrial use or by purchase, consignment or bailment, and which stores, grades, processes, melts, cuts, dismantles, compresses, cleans, or in any way prepares the items for reuse by the connected other general industrial use or for sale and shipment and use in other industries or businesses, including open hearth, electric furnaces and foundry operations. Shall not include junkyards, dumps, or automobile graveyards.

SETBACK – A line indicating the minimum horizontal distance between the right-of-way of any street or property line (whichever is closer) and the foundation (or eave if over 16”). If no foundation is involved, the setback would be measured to the edge of the structure nearest the associated property line or right-of-way.

SEWAGE TREATMENT PLANT, PRIVATE – A facility that will handle all effluent from a building or buildings on-site constructed on-site which is maintained by the private homeowner or an association.

SEWER, PRIVATE - A disposal system, which is not constructed, installed, maintained, operated or owned by a municipality, taxing district established for that purpose or a utility under the jurisdiction of the Indiana Utility Regulatory Commission.

SEWER, PUBLIC - A sewage disposal system which is constructed, installed, maintained, operated and owned by a municipality or taxing district established for that purpose.

SHOOTING RANGE, INDOOR – The use of a structure for archery and/or the discharging of firearms for the purposes of target practice or temporary competitions.

SHOOTING RANGE, OUTDOOR - The use of land for archery and/or the discharging of firearms for the purposes of target practice, skeet and trap shooting, mock war games, or temporary competitions, such as turkey shoots. Excluded from this use type shall be general hunting and unstructured and nonrecurring discharging of firearms on private property with the property owner's permission.

SIDEWALK - A paved surfaced or leveled area, usually parallel to and separate from the street, used as a pedestrian walkway.

SIGN - Any communication device, structure or fixture (including but not limited to letters, words, numerals, figures, emblems, pictures or any part or combination thereof), used for visual communication intended to attract the attention of the public and visible to the public right-of-way or other property. The term "sign" shall not include any flag, badge or insignia of any governmental unit, any item of merchandise displayed within a show window of a business or any graphic display mounted or placed within a building or on the inside of a window even if visible to the public when outside of the building. A sign may have multiple elements if, in the sole opinion of the Executive Director, those elements are related and critical to a sign's single message.

SIGN, ABANDONED – A sign that no longer correctly identifies or advertises a bona fide business, lease or, owner, product or activity.

SIGN, A-FRAME: A sign which bears the resemblance of an "A" in shape and is generally designed to sit unsecured on the ground or placement surface.

SIGN, AGRICULTURAL – A sign related to the sale or use of products related to farming activity and placed on the grounds of farm property.

SIGN, ANIMATED – Any sign that uses movement or change of lighting to depict action or create a special effect or scene.

SIGN AREA - The two-dimensional space utilizing the smallest circle, triangle or rectangle which encloses all elements, excluding the structure unless said structure is a part of the sign proper or display. (See Subsection 10.6.1 for further clarification).

SIGN, AWNING – A sign located on the surface of a structure extending from a building where the structure is utilized to help protect persons or building from outdoor weather conditions.

SIGN, BACK TO BACK (DOUBLE FACED) – See Subsection 10.6.2 Back-to-back signs.

SIGN, BANNER - A temporary sign composed of lightweight, flexible material either enclosed or not enclosed in a rigid frame.

SIGN, BANNER SEASONAL – A banner that displays seasonal themes.

SIGN, BENCH – A sign printed on or mounted to a bench.

SIGN, BILLBOARD – An outdoor advertising sign with a sign area of no less than three hundred (300) square feet and no more than four hundred-fifty (450) square feet.

SIGN BILLBOARD, DIGITAL - Billboards which are electronic image displays, generally computer controlled, using LED or other lighting technology, to present images which may be stationary, moving or a combination thereof. Images and/or ads may rotate or change frequently in slide show fashion. They generally display multiple advertisements or a rotating basis or in slide show fashion. Larger outdoor billboards usually appear alongside roadways, while smaller billboards appear in entertainment venues, such as sports arenas.

SIGN BILLBOARD, TRADITIONAL - Billboards which have a printed face which can be developed on a variety of substrates or in various manners and which have a static message for an agreed upon amount of time, normally measured in day or weeks. Other than exterior illumination features, traditional billboards have no electronic components.

SIGN, CANOPY – A sign located on the surface of a structure extending from a building where the structure is utilized to help protect persons or building from outdoor weather conditions.

SIGN, CHANGEABLE COPY – A sign or portion thereof with characters, letters, or illustrations that can be changed or rearranged without altering the face of the sign.

SIGN COPY (Permanent or Temporary) – The wording or any graphic illustrations on a sign surface either in permanent or removable letter form.

SIGN, DISPOSABLE – A sign intended to be displayed just above the ground which is not permanently affixed and does not use a durable framing material such as metal or wood in its construction.

SIGN, ELECTRONIC MESSAGING; ELECTRONIC MESSAGING CENTER – A sign that is capable of displaying words, symbols, figures or images in an electronic format that can be changed by manual, remote or automatic means.

SIGN FACE - The surface of the sign upon, against or through which the message of the sign is exhibited.

SIGN, GATEWAY - Any permanent, freestanding sign marking the location at which a public street enters a city, town, subdivision, office park or similar unified development which provides only the name of that development. Gateway signs are subject to the same standards, regulations and restrictions as a “Ground” sign.

SIGN, GROUND - A sign supported by one or more uprights or bases in the ground with a sign height of six (6) feet or less.

SIGN, HEIGHT – The distance measured from the average surface grade surrounding the base of a sign to the top of the highest element of the sign. See figure 10.1

SIGN, HISTORICAL - A sign issued by a Federal, State or Local governmental agency/department or to which such agency provides specific design and/or construction standards and which are intended to designate an historic location, site or landmark. Such signs may not be placed in any public right-of-way unless authorized by the appropriate local, legislative body and/or the controlling State or Federal agency/department issuing the sign and/or standard. Nor may the sign be placed in any manner which, in the sole opinion of the Executive Director, would create a nuisance or unsafe condition.

SIGN, HOME OCCUPATION – A sign pertaining to an occupation which is conducted out of a dwelling or one of its accessory structures.

SIGN, ILLEGAL - Signs that do not comply with the Zoning Ordinance.

SIGN, INCIDENTAL - A sign, generally informational with no advertising or promotional message, that has a purpose secondary to the use of the lot on which it is located, such as “no parking”, “Employee of the Month”, “Reserved”, “Entrance”, “Loading Only”, “Keep off the Grass”, and other similar directives.

SIGN, LED – A sign utilizing LED or similar technology to convey its message or advertisement.

SIGN, MARQUEE - A sign located on the surface of a structure extending from a building where the structure is utilized to help protect persons or building from outdoor weather conditions.

SIGN, MONUMENT A monument sign is a permanent, exterior freestanding sign that is not affixed to a building. This kind of sign either sits directly on the ground, on a concrete foundation or is on a low base that makes the sign highly visible and easy to read from the street level. These type signs are classified as “Ground Signs”.

SIGN, MULTI-FACED - Any sign with two (2) or more display or advertising surfaces.

SIGN, MULTIPLE ENTITIES – An on-premise sign or family of signs which includes advertising, messages and/ or identities of more than one business, organization, governmental entity or combination thereof, mounted to a single structure and promotes or identifies entities located on the same parcel/lot as the sign. This category does not include Shared Advertising Signs.

SIGN, NATURAL COMPOSITE - Any sign whose base material is stone, rock, marble, wood or any other natural mineral and is independent of any building or structure.

SIGN, NON-CONFORMING – A sign lawfully erected and maintained prior to the adopting of this ordinance that does not conform with the requirements of this ordinance.

SIGN, NON-PERMANENT – A sign which can be moved or removed without impacting its structure.

SIGN, OFF-PREMISE - A sign that directs attention to a business, commodity, service, organization, activity or entertainment conducted, sold or offered elsewhere than upon the premises where such sign is located or to which it is affixed. This includes billboards.

SIGN, ON-PREMISE - A sign which occupies the same parcel of ground as the business, institution, facility, service or activity of the site.

SIGN, OUTDOOR ADVERTISING – See Billboard.

SIGN, PENNANT – See Banner.

SIGN, PERMANENT – A sign which utilizes footings, a foundation and/or securely attached mounting fixtures as part of its structure.

SIGN, PERMANENT, IDENTIFICATION – A sign in a residential district that provides information regarding ownership, location, use and/or name of a complex used for dwelling purposes; a sign which provides, but is not limited to, information on ownership, location, use and/or name of an institution.

SIGN, POLE - A free-standing sign, usually double-faced, mounted on one or more round poles, square tubes or other fabricated members without any type of secondary support with a sign height greater than six (6) feet.

SIGN, PROJECTION - Any sign supported by a building or other structure and extending outward more than twelve (12) inches or where the face of the sign is perpendicular to surface of the building or structure to which it is mounted.

SIGN, PUBLIC - - A sign authorized by a governmental body or agency or department thereof, limited to providing public safety notices or general information pertinent to the health, safety and welfare of the general public. For purposes of this Ordinance, these signs are treated as public notices and exempt from zoning ordinance regulations and standards.

SIGN, REAL ESTATE – A sign promoting the sale and/or lease of a parcel and/or structure

SIGN, RECONSTRUCTION – Replacement of any sign structure component, excluding mounting or assembly hardware.

SIGN, ROOF - A sign located on or above a roof and which is either directly or indirectly attached to the roof via some type of hardware, framework, brackets or similar device(s) or method(s). Supplemental support or attachment mechanisms and methods secured to a wall or some other structure other than the roof is sometimes required for safety and security reasons.

SIGN, SEARCHLIGHT – A sign projecting a powerful beam of light, either rotating or not, into the atmosphere.

SIGN, SHARED ADVERTISING – Pole signs that are adjacent to an Interstate highway and advertise multiple businesses located near an exit.

SIGN STRUCTURE - The supports, uprights, bracing and frame work for the sign, other than integrated framework on a prefabricated sign. In the case of a sign structure consisting of two or more sides, where the angle formed between any of the sides (or the projection thereof) exceeds fifteen (15) degrees, each side shall be considered a separate sign structure.

SIGN, SUSPENDED – A sign that is suspended from the underside of a horizontal plane surface and is supported by such surface.

SIGN, TEMPORARY – A sign not intended to be permanently affixed.

SIGN, T-FRAME: A sign which bears the resemblance of a “T” in shape and is generally designed to sit unsecured on the ground or placement surface.

SIGN, TOWER – A sign placed on any communication, radio, cell tower or on a wind turbine.

SIGN, VEHICLE - Any motor vehicle or trailer, not regularly used for commercial purposes or is not part of a company’s product inventory which has painted or mounted on it, any sign and which is located in any parking lot, driveway or yard for more than five (5) consecutive business days.

SIGN, WALL – Any sign attached parallel to a wall or painted on the wall surface and supported by such wall or building. Wall signs shall not project more than twelve (12) inches from the building.

SIGN, WINDOW – A sign which utilizes the glass of a window as the surface for placing or constructing of a sign or advertising information and placed entirely within the frame of a window. Any window sign utilizing internal or external illumination must comply with the illumination standards provided in Section 10.4.

SIGN, YARD – A sign designed to be displayed just above the ground which is not permanently affixed, but which uses durable material such as metal or wood for framing.

SITE DEVELOPMENT PLAN – Also referred to as development plan or site plan. A detailed plan, prepared in accordance with the rules and regulations of the appropriate jurisdiction, and submitted to the Plan Commission or other designated body or authority for review and approval. The plan shall illustrate the proposed development or alterations of a site.

SLAUGHTER HOUSE – An independent, commercial facility where animals are killed or where animal carcasses are imported and, in each case, used to be processed for consumption as food products or other commercial purposes. Slaughter House does not include a grocery store, supermarket or other retail food products store which provides butchering as a supplemental service secondary to their other store offerings. A Slaughter House located on a site also

used for a Confined Feeding operation, Digester Operation or other Agricultural Use is considered an accessory use to those activities and exempt from the requirements of Chapter 3, Section 3.19 of the White County Indiana Zoning Control Ordinance.

SLOPE - The face of an embankment or cut section. Any ground whose surface makes an angle with the plane of the horizon. Slopes are usually expressed in a percentage based upon vertical difference in feet per 100 feet of horizontal distance.

SMELTING PLANT – A facility which uses heat, a chemical reducing agent or some other technological method to extract a base metal from a hosting ore. These facilities are classified as “Heavy Manufacturing” plants.

SOCIAL SERVICES - A wide variety of professional activities or methods concerned with providing assistance in various forms to disadvantaged, distressed or vulnerable persons or groups. Social services may serve the needs of children and families, the poor or homeless, immigrants, veterans, the mentally ill, the handicapped, victims of rape or domestic violence or persons dependent on alcohol or drugs. Many such services are often referred to as welfare. For ordinance purposes, refer to the category of Personal/Professional Services.

SOLAR ARAY (aka PHOTOVOLTAIC ARRAY) - Two or more solar panels linked or connected together for the purpose of generating electricity.

SOLAR ARRAY, STEM STYLE - A solar array construction where each solar panel is attached to a support frame, bracket, stand or other apparatus or which utilizes a ballasted footer for panel stabilization. Tree style solar arrays are excluded from this category.

SOLAR ARRAY, TREE STYLE (aka SOLAR TREE) - A solar array construction utilizing a common, vertical “trunk” frame to which extending panel support framework is constructed. This design often mimics the trunk and limb visual image of a natural tree. Tree style solar array units extend vertically a minimum of six feet (6’) from ground or trunk support foundation level. Framework and panel attaching mechanisms may be designed to rotate to maximize a panel or array’s conversion efficiency.

SOLAR CELL (aka PHOTOVOLTAIC or PHOTOELECTRIC CELL) - An electrical device that converts sunlight, or other form of visible light, directly into electricity and is a building block of Solar Panels or used on their own as a power supply for calculators, lights, clocks or individual devices.

SOLAR ENERGY PROJECT – Any development of energy generation involving devices or components which utilize the sun’s rays and/or heat as fuel source.

SOLAR ENERGY PROJECT DEVELOPER – The primary person or entity responsible for development of a solar energy project.

SOLAR ENERGY PROJECT OPERATOR – The primary person or entity responsible for a solar energy systems on-going operations.

SOLAR ENERGY PROJECT OWNER – The person(s) or entity/entities who owns or will own one (1) or more solar energy systems proposed to be located in a site development.

SOLAR ENERGY SYSTEM (SES) - Solar cells, panels and/or arrays, converters and solar infrastructure used to generate thermal heat or electricity.

SOLAR ENERGY SYSTEM, COMMERCIAL (CSE or CSE System) - A system that captures and converts solar energy into electricity that is generated primarily for (1) the purpose of selling electricity at wholesale and (2) for use in locations other than where it is generated and which has a nameplate capacity of at least ten (10) megawatts. The term includes collection and feeder lines, substations, ancillary buildings, solar monitoring stations and accessory equipment or structures. Accessory equipment or structures shall include, but is not limited to, a configuration of solar arrays, converters, transformers, switch cabinets and energy storage devices/housings.

SOLAR ENERGY SYSTEM, COMMERCIAL, PROJECT AREA (Solar Project Boundary) – The area defined by the perimeter property lines, (those property lines not shared with another participating property owner) of all parcels/lots of land identified as participating property owners in a common solar energy project, including any abutting rights-of ways captured within two or more participating properties.

SOLAR ENERGY SYSTEM, COMMUNITY - A Solar Energy System for use with single, two-family or multi-family private dwellings or with business, industrial or commercial applications where the electricity or thermal energy is consumed by individuals or businesses which may or may not be on the parcel upon which the system is located. Energy is not sold for wholesale purposes. This solar system is an accessory use designed to supply electricity or

thermal energy to a community of properties. Solar energy components may be roof top mounted, ground mounted or building integrated.

SOLAR ENERGY SYSTEM COMPOUND/SOLAR ENERGY SYSTEM “OUTER EDGE” – The smallest square, circle, triangle or rectangle which captures the area of land upon which is placed the solar panels, solar arrays, inverters, solar panel/array support and connecting brackets, structures and wiring, transformers, switch cabinets, electricity storage devices, housing as well as any other equipment or facilities associated with a solar energy project. Land used for the infrastructure required to connect to a utility service is not included.

SOLAR ENERGY SYSTEM, CONCENTRATED (CSP) - A Solar Energy System which incorporates mirrors and/or lenses to concentrate sunlight as a component of their operation.

SOLAR ENERGY SYSTEM, INDIVIDUAL (ISE) - A Solar Energy System for use with single, two-family or multi-family private dwellings or with business, industrial or commercial applications where the electricity or thermal energy is consumed on-site and not sold for commercial purposes. This solar energy system is an accessory use designed only to supply electricity or thermal energy to the principal and accessory uses of the site. Solar energy components may be roof top mounted, ground mounted or building integrated.

SOLAR ENERGY SYSTEM, SHARED (SSE) - A Solar Energy System for use with single, two-family or multi-family private dwellings or with business, industrial or commercial applications where the electricity or thermal energy is consumed by individuals or businesses which may or may not be on the parcel upon which the system is located. Energy is not sold for wholesale purposes. This solar system is an accessory use designed to supply electricity or thermal energy to a community of properties. Solar energy components may be roof top mounted, ground mounted or building integrated.

SOLAR FARM (SF): (aka PHOTOVOLTAIC POWER STATION, SOLAR PARK, SOLAR RANCH, SOLAR STATION or UTILITY-SCALE SOLAR STATION, CONCENTRATED SOLAR FACILITY) - A commercial facility constructed with a configuration of Solar Arrays for which the principal purpose is to generate electricity to be sold on a wholesale basis for ultimate placement on the Nation’s electrical grid. This is the principal use for the parcel on which it is located.

SOLAR FARM, PHOTOVOLTAIC POWER STATION, SOLAR PARK, SOLAR RANCH, SOLAR STATION or UTILITY-SCALE SOLAR STATION, CONCENTRATED SOLAR FACILITY) – See Commercial Solar Energy System (CSE):

SOLAR FARM COMPOUND - The area of land upon which is placed the solar panels, solar arrays, inverters, solar panel/array support and connecting brackets, structures and wiring as well as any other equipment associated with a Solar Farm installation. Land used for the infrastructure required to connect to the utility service is not included.

SOLAR FARM, CONCENTRATED (CSP) - A Solar Farm which incorporates mirrors and/or lenses to concentrate sunlight as a component of their operation.

SOLAR INSTALLATION, FLOATING - A solar energy system which is constructed on floaters or raft type structures designed to be placed on water surfaces or in areas prone to flooding where the system is designed to deal with the movement and changes in water levels associated with the subject site.

SOLAR INSTALLATION, GROUND MOUNT - A solar energy system which uses stem style solar arrays where no point of the solar array exceeds 10 feet (10’) in height. In stem style solar arrays, panels are mounted essentially parallel to the earth’s surface in a horizontal configuration. In a stem style solar array, the tallest point of the array extends no higher than ten feet (10’) from the ground or base support level. Framework and panel attaching mechanisms may be designed to rotate to maximize a panel or array’s conversion efficiency.

SOLAR INSTALLATION, INTEGRATED - A solar energy system where solar panels and/or arrays are integrated within the design of the exterior components of any building or structure, excludes Roof Top Installations.

SOLAR INSTALLATION, ROOF TOP - A solar energy system where all solar panels or arrays are mounted via some type of framing or bracketry directly to the roof of a primary or accessory buildings or structures. Also included are systems utilizing Solar Shingles.

SOLAR PANEL (aka PHOTOVOLTAIC MODULE) - A bank of interconnected solar cells combined into the form of a panel normally contained by a metal or plastic perimeter frame.

SOLAR SHINGLE (PHOTOVOLTAIC SHINGLE) - Solar panels or solar modules designed to look like and function as conventional roofing materials, such as asphalt or slate, while also producing electricity. These shingles are

constructed with the same durability and flexibility as regular shingles and are designed to withstand rain, wind and hail. Solar shingle installations can also be known as building-integrated photovoltaics.

SPECIAL EVENT – A one-time or infrequently occurring activity held by a private group of persons, firm, organization, association, non-profit entity or business which occurs unrelated to the principal use of the property.

SPORTING EVENT (FOR PROFIT) – An organized activity involving physical exertion and skill that is governed by a set of rules, normally in a competitive environment, operated for the profit of an organization, institution, private party or group of individuals and taking place in a single day or over a period not to exceed seven (7) days. Excluded are sporting events which constitute extra-curricular activities of public or religious institutions.

SPECIAL EXCEPTION USE – A special exception is a use that would not be appropriate generally or without restrictions throughout the zoning division or district but which, if controlled as to number, area, location, or relation to the neighborhood, would promote the public health, safety, welfare, morals, order, comfort, convenience, appearance, prosperity, or general welfare. Such uses may be permitted in such zoning division or district as special exceptions, if specific provisions for such special exceptions are made in this ordinance.

SPECIAL FLOOD HAZARD AREA (SFHA) – Those lands within White County that are subject to inundation by the regulatory flood. The SFHA's of White County are generally identified as such on the Flood Insurance Rate Map of the County as prepared by the Federal Emergency Management Agency and dated September 1, 1988.

STABLE OR BOARDING, COMMERCIAL - Any stable for the housing of horses, mules, donkeys or ponies, operated for remuneration, hire, sale, or stabling; or any stable, not related to the ordinary operation of a farm, with a capacity of more than four (4) horses, mules, donkeys or ponies, whether or not the stable is operated for remuneration, hire, sale or stabling. All stables or boarding outside this definition are considered stables or boarding facilities for private use.

STABLE OR BOARDING, PRIVATE – Any non-commercial stable or boarding operation.

STADIUM, COLISEUM, ATHLETIC FIELD (COMMERCIAL) – A large building with tiers of seats for spectators at sporting or other recreational events.

STAFF – The staff of the Area Plan Commission of White County.

STATE AGENCY - As used in this Ordinance, the term state agency shall mean and include all state agencies, boards, commissions, departments, and institutions, including state educational institutions of the State of Indiana.

STOCKYARD – A large enclosed yard, usually with pens or stables, in which livestock, such as cattle or pigs, are temporarily kept until slaughtered, sold, or shipped elsewhere.

STOOP - A flat area at the front door of a house intended to facilitate entrance to a home; it may or may not be roofed and does not exceed four feet by six feet in size.

STORAGE, BULK - On-site storage of any soil, sand, gravel, clay, mud, debris, vegetation, refuse or any other material, organic or inorganic, in a concentrated state. Storage or parking of motor vehicles but not for the repair or servicing thereof.

STORAGE, COMMERCIAL – A structure whose main use is housing non-agricultural items related to a commercial enterprise. This type of facility is only staffed with employees on an intermittent basis.

STORAGE FACILITY, SELF SERVICE – A building or group of buildings divided into separate compartments used to meet the temporary storage needs of small businesses, apartment dwellers, and other residential uses; and may include refrigerated facilities. A Self Service Storage Facility does not include the keeping of goods, vehicles, materials, equipment or similar such items in any completely unenclosed area.

STORAGE GARAGE – See Garage. A structure or part thereof used for the storage, parking, or servicing/repair of motor vehicles owned by and registered to the property owner or occupant.

STORAGE, OUTSIDE – The keeping of goods, materials, equipment or other property in a location not completely enclosed by walls and a roof.

STORAGE, PERSONAL – A structure whose main use is housing non-commercial items belonging to the property owner or occupant.

STORAGE, PORTABLE – A container, shed, trailer or similar structure, temporarily positioned and not permanently affixed and readily movable upon demand; in which personal items, inventory or equipment are stored.

STORAGE SHED or MINI-BARN - An accessory structure used primarily for storage purposes.

STORAGE TANK, FUEL (COMMERCIAL) – A container or vessel designed and constructed to hold large quantities of fuels (more than five hundred (500) gallons) and is stored pending distribution to points of consumption or redistribution or which is utilized for on-site use.

STORAGE TANK, FUEL (PRIVATE) – A container or vessel limited to holding five hundred (500) US gallons or less of gasoline, kerosene, fuel oil or some other liquid fuel used on-site by the owner or tenant of the property.

STORAGE TANK, GAS (COMMERCIAL) – A container or vessel designed and constructed to hold large quantities (more than five hundred (500) US gallons) of some type of hydrocarbon gas mixture from a source of supply which is then stored pending distribution to points of consumption or for on-site use.

STORAGE TANK, GAS (PRIVATE) – A container or vessel limited to holding five hundred (500) US gallons or less of some type of hydrocarbon gas mixture, normally propane, which is then utilized on-site for personal use such as heating, clothes drying, hot water heating or other personal use.

STORAGE TANK, OIL – A container or vessel designed and constructed to hold oil or other petroleum products pending on-site processing or distribution to processing sites at other locations.

STORAGE TANK, WATER/WATER TOWER – A container or vessel, which may or may not be completely enclosed, which is designed and constructed to hold water, accumulated on-site or from an outside source, which is then stored pending distribution to points of consumption or for on-site usage.

STORAGE YARD - A parcel of ground where the primary use, in whole or part, is for the storage of materials, refuse or equipment (not including junk) which is clean, quiet and free of any objectionable or hazardous element.

STORY - That portion of a building included between the surface of any floor and the surface of the floor next above it. If there is no floor above it, then the space between such floor and the ceiling next above it shall be the Story. For the purpose of this ordinance, a basement shall not be considered a story unless it has been subdivided into rooms and used for tenant purpose.

STORY, HALF - That portion of a building under a sloping, gable, hip, or gambrel roof, the wall plates on at least two opposite exterior walls of which are not more than three (3) feet above the floor level of such half-story.

STREET – A right-of-way that is established for public or private use to provide the principal means of access by the motoring public to abutting property. Types of streets include the following:

ALLEY - A public or private street primarily designed to serve as a secondary access to the side or rear of those properties.

ARTERIAL - Either a boulevard, primary arterial or secondary arterial as defined in this section.

BOULEVARD - A divided arterial street or portion thereof which has a landscaped median strip dividing the lanes carrying traffic in opposite directions.

PRIMARY ARTERIAL - A street intended to move through traffic to and from such major attractors as central business districts, regional shopping center, colleges or universities, military installations, major industrial areas and similar traffic generators within the county, and/or as a route for traffic between communities; a major intra- or inter-city thoroughfare as designated by and shown on the Thoroughfare plan.

SECONDARY ARTERIAL - A street intended to collect and distribute traffic in a manner similar to primary arterials, except that these streets service minor traffic-generating areas such as community-commercial areas, primary and secondary educational facilities, hospitals, recreational areas, churches, and offices, and/or designed to carry traffic from collector streets to the system of primary arterials as designated by and shown on the Thoroughfare Plan.

STREET, DEAD-END - A local street with only one (1) outlet and not having an appropriate terminus (turnaround) for the safe and convenient reversal of traffic including public safety vehicles.

STREET, FRONTAGE - A street intended to move traffic from either a residential neighborhood or a commercial or industrial area to an arterial street, with the purpose of controlling the location and spacing of access points to the arterial street and thereby protecting the integrity of the arterial street as a major mover of traffic. A frontage street usually runs parallel to the related arterial street and may have development only along one (1) side.

STREETS, NONRESIDENTIAL. May be either of the following:

COLLECTOR - A road intended to move traffic from local roads to secondary arterials. A collector road serves a neighborhood or large subdivision.

LOCAL SERVICE - A street intended to provide access to other streets from individual properties in nonresidential areas.

STREET, MAJOR - Any arterial or collector street.

STREET, PERIMETER - Any existing street to which the parcel of land to be subdivided abuts on only one (1) side.

STREET, PLACE - A short residential local service street, cul-de-sac, or court with a maximum development potential of ten (10) residential units.

STREET, PRIVATE - A right-of-way or easement for the public use for vehicular and pedestrian traffic, which is owned and maintained by a private person or entity and not by a governmental body. Use of a private street may be limited by its owner or owners. Private streets may serve residential or nonresidential properties.

STREET, PUBLIC - A right-of-way dedicated for the public use for vehicular and pedestrian traffic to be owned and maintained by the governmental body having jurisdiction. Other ancillary uses such as drainage and/or utility facilities may also be included within public rights-of-way.

STREETS, RESIDENTIAL - Any of the streets defined as follows:

COLLECTOR - A street intended to move traffic from local streets and cul-de-sacs in residential neighborhoods to primary or secondary arterials as designated and shown on the Thoroughfare Plan.

CUL-DE-SAC - A local street with only one (1) outlet and having an appropriate terminus (turnaround) for the safe and convenient reversal of traffic movement, including public safety vehicles, and intended to provide access to other streets from individual properties in residential neighborhoods.

LOCAL SERVICE - A street intended to provide access to other streets from individual properties in residential neighborhoods.

STREET VENDOR - Any person or entity engaged in the sale of food, beverages, merchandise, or services for immediate or timed delivery from a vendor stand, table, vehicle, trailer or other readily movable structure or from his or her person. These activities are not located in a building nor operate under the same registered retail merchant's certificate as any other business on the same lot. For door-to-door sales to residences, see Peddler.

STRUCTURAL ALTERATION - Any change in the supporting members of a building, such as bearing walls or partitions, columns, beams or girders, or any substantial change in the exterior walls or the roof.

STRUCTURE - Anything constructed or erected which requires location on or in the ground or attachment to something having a location on or in the ground. The term also includes a gas or liquid storage tank, a manufactured home, or a prefabricated building. The term also includes recreational vehicles to be installed on a site for more than 180 days.

STRUCTURE, NON CONFORMING (LEGALLY ESTABLISHED) - Any continuous, lawfully established building or structure erected or structurally altered prior to the time of adoption, revision, or amendment of this Ordinance or granted a variance from this Ordinance, but which fails, by reason of such adoption, revision, amendment, or variance, to conform to the present requirements of the zoning district in which it is located.

STRUCTURE, PRIMARY - A structure which is the main or principal structure on the lot on which said structure is situated.

STRUCTURE, TEMPORARY - A structure without any foundation or footings and which is removed when the designated time period, activity or use for which the temporary structure was erected has ceased.

SUBDIVIDER - Any person having an interest in land that is the subject of an application for subdivision. Also, a person submitting an application for a subdivision.

SUBDIVISION - The division of land as defined in The White County Subdivision Control Ordinance.

SUBDIVISION, AMENDED - A change in a recorded subdivision plat if the change affects any street layout or area reserved thereon for public use of any lot line; or if it affects any map or plan legally recorded prior to the adoption of any regulations controlling subdivisions.

SUBDIVISION, MAJOR –The process of laying out a parcel of raw land into lots, blocks, streets, and public areas for residential development.

SUBSTANTIAL DAMAGE - Damage of any origin sustained by a structure whereby the cost of restoring the structure to its before-damaged condition would equal or exceed 50 percent of the market value of the structure before the damage occurred.

SUBSTANTIAL IMPROVEMENT – Any reconstruction, rehabilitation, addition, or other improvement of a structure, the cost of which equals or exceeds fifty (50) percent of the market value of the structure before the start of construction of the improvement. This term includes structures which have incurred “substantial damage” regardless of the actual repair work performed. The term does not include improvements of structures to correct existing violations of state or local health, sanitary, or safety code requirements or any alteration of a “historic structure”, provided that the alteration with not preclude the structures continued designation as a “historic structure.”

“Substantial” Modification (as it pertains to a wireless support structure) – a modification of a wireless support structure by the greater of: 1) ten percent (10%) of the original height of the wireless support structure or 2) twenty (20) feet; or, addition of an appurtenance to the wireless support structure that protrudes horizontally from the wireless support structure more than the greater of: 1) twenty feet or 2) the width of the wireless support structure at the location of the appurtenance or 3) increases the square footage of the equipment compound in which the wireless facility is located by more than two thousand five hundred (2,500) feet. The term does not include increasing the height of a wireless support structure to avoid interfering with an existing antenna or increasing the diameter or area of a wireless support structure to shelter an antenna from inclement weather or connect an antenna to a wireless support structure by cable.

SUBSTATION (WECS) – A structure containing apparatus that connects the below- or above-ground electrical collection lines of the WECS to the electric utility grid, with or without increasing the voltage.

SUPPORT SYSTEM (FOUNDATION) - A combination of footings, piers, caps, plates, and shims, which, when properly installed, support the manufactured or mobile home; footings being the part of the support system which transmit loads to the soil at or below the surface and the frost line; piers and caps being the part of the support system between the footing and the home, exclusive of plates and shims; plates and shims being the cushion of wood or other approved material, which are used to fill the gap between the top of the pier caps and the frame of the home.

SWIMMING POOL, PRIVATE - A swimming pool used only by the owner of the pool and the owner’s invited guests, and which is an accessory use at a private residence or private commercial operation.

T

TABLED – The Plan Commission has determined by motion and vote to carry over an agenda item for discussion at the next regularly scheduled meeting.

TATTOO PARLOR - A commercial business where tattooing is performed for compensation.

TATTOOING – A placement in human tissue of any indelible design, letter, scroll, figure, symbol, or other mark placed with the aid of needles or other instruments; or any design, letter, scroll, figure, or symbol done by scarring upon or under the skin.

TAVERN - An establishment where alcoholic beverages are sold to be drunk on the premises. Includes bars, night clubs, and cocktail lounges.

TAXICAB - A vehicle for hire which includes a provided driver which conveys passengers between locations of their choice which charges a fare, historically determined by a taximeter. A Taxicab is limited to no more than seven (7) passengers.

TAXICAB COMPANY – A private enterprise which offers Taxicab services to the general public.

TECHNICAL REVIEW COMMITTEE - A panel established by the County to provide technical knowledge and services to the Area Plan Commission in the administration of the zoning and subdivision control ordinances.

TEMPORARY STRUCTURE - A structure without any foundation or footing and removed when the designated time period, activity, or use for which the temporary structure was erected has ceased.

TEMPORARY USE – Those land uses and structures that are needed or are in place for only short periods of time.

TENT - A tent is a portable, collapsible shelter which utilizes a fabric covering supported by one or more poles and secured by ropes or rope equivalents fastened to pegs in the ground. A carport or accessory port, even if one utilizes a canvas covering is not a tent.

TERRACE (VERANDA) - A deck which is raised more than six (6) feet above grade.

THEATER, INDOOR - A building or part of a building devoted to showing motion pictures, or for dramatic, dance, musical, or other live performances.

THEATER, OUTDOOR – An outdoor area, building, part of a building, structure, or defined area utilized primarily for the presentation of film, television, music video, multimedia, performing arts or other related activities. Also, includes a drive-in theater.

THERAPEUTIC HORSEBACK RIDING/EQUINE-ASSISTED ACTIVITY/ADAPTIVE RIDING – A facility at which disabled individuals ride horses to relax, to develop muscle tone and coordination as well as build individual confidence and well-being.

THOROUGHFARE PLAN - The part of the Comprehensive Plan, now or hereafter adopted, which includes a major street and highway plan and sets forth the location, alignment, dimensions, identification, and classification of existing and proposed streets, highways, and other thoroughfares.

TICKET BOOTH - A temporary building and located on private property for the purpose of manually or electronically charging pedestrian or vehicular traffic a fee in association with entertainment associated with Indiana Beach without impeding or restricting ingress or egress.

TOWNHOUSE - A single-family dwelling unit constructed in a row of attached units that are separated by property lines with open space on at least two (2) sides.

TRACT - Any area of land that has not been subdivided by this Ordinance or any prior subdivision ordinance or that area of a larger property that remains after a subdivision or exempt division and is typically described by metes and bounds or aliquot part.

TRAFFIC CONTROL DEVICES - All signs, signals, markings and devices placed or erected by authority of the Governing Body, complying with the State Statute Manual of Uniform Traffic Control Devices.

TRANSFER STATION, OTHER – A place or facility where non-hazardous materials or products are taken from a transport vehicle (railway, plane, trailer, automobile, truck, van or any other similar unit used for transporting materials from one location to another) with the intent of transferring that material or product to another transport vehicle for conveyance to another site and where any on-site storage of materials or products does not exceed seven (7) days.

TRANSFER FACILITY, SOLID WASTE -A place or facility where nonhazardous solid waste materials are taken from a collection vehicle, temporarily stored or stockpiled, and ultimately placed in a transportation unit for movement to another facility.

TRAVEL TRAILER - A vehicular, portable structure designed or used as a recreational dwelling, no more than thirty-five (35) feet in length built on a chassis, having a body width not exceeding eight feet and designed to move on the highway, not under its own power.

TRUCK FREIGHT TERMINAL – A building or area in which freight brought by motor truck is assembled and/or stored for routing in intrastate shipment by motor truck.

TRUCK STOP - A site providing specialized facilities for retail fueling services for Class I, II, III and higher commercial and personal vehicles; the site may include related facilities including but not limited to retail sales of groceries and household items, restaurants, showers and overnight parking.

TRUCK WASH - An activity conducted for the purposes of cleaning Class III or higher commercial vehicles, whether performed automatically, semi-automatically or manually.

U

URBAN AREA – Land within a city or town’s corporate boundaries or any area where the residential density is such that there are 8 residences with a quarter-mile-square area extending beyond the city or town’s corporate boundaries or if the land surrounding the corporate boundaries has already been approved for residential development and the minimum density of the proposed development is 8 residences within a quarter-mile-square area.

USE - The purpose for which a lot, building or other structure or tract of land may be designated, arranged, intended, maintained or occupied; or any activity, occupation, business, or operation carried on or intended to be carried on in a building or other structure on a tract of land.

USE, CONFORMING - A use or activity of a structure or land that is permitted or approved as a special exception use in the district where it is situated and which lawfully conforms to the regulations of that district in which it is located and all other regulations of this Ordinance.

USE, EXISTING - The use of a lot or structure at the time of the enactment of this Ordinance.

USE, INCOMPATIBLE – A use or service that is capable of direct association with certain other uses because it is contradictory or incongruous.

USE, NON-CONFORMING - A use or activity of structure or land which lawfully existed prior to the adoption, revision, or amendment of this Ordinance, but which fails by reason of such adoption, revision or amendment to conform to the use district in which it is located.

USE, PERMITTED -- A use which may be lawfully established in a particular district or districts (provided it conforms with all requirements, regulations, and performance standards, if any of such district).

USE, PRINCIPAL - The primary use to which a property is devoted and as the main purpose for which the property exists. A principal use may be authorized as either a permitted use or a special exception use.

USE, SPECIAL EXCEPTION – The authorization of a use that is so designated as being permitted in the district if it meets special conditions, and upon application, is specifically authorized by the Board of Zoning Appeals.

USE, TEMPORARY - A prospective use, intended for limited duration, to be located in a zoning district not permitting such use, and not continuing a nonconforming use or building.

UTILITIES - Infrastructure services, including those basic utilities, and the structures necessary to deliver those services. Those services may be provided by a public or private agency. Examples include water, sanitary sewer, electricity, natural gas, and telephone.

UTILITY FACILITY, PUBLIC A building or structure used or intended to be used by any public utility, including but not limited to any wastewater treatment plant reservoir, tank, or other storage facility; water treatment plant, well, reservoir, tank, or other storage facility; electric generating plant, distribution, or transmission substation; telephone switching or other communications plant, earth station, or other receiving or transmission facility; any storage yard for utility equipment or vehicles; gas line; and any parking lot for parking vehicles or automobiles to serve the utility.

UTILITY FACILITY, PRIVATE - A building or structure used or intended to be used by any private utility, including but not limited to any wastewater treatment plant reservoir, tank, or other storage facility; water treatment plant, well, reservoir, tank, or other storage facility; electric generating plant, distribution, or transmission substation; telephone switching or other communications plant, earth station, or other receiving or transmission facility; any storage yard for utility equipment or vehicles; gas line; and any parking lot for parking vehicles or automobiles to serve the utility.

UTILITY INSTALLATIONS, PUBLIC - The erection, construction, alteration, or maintenance by public utilities, municipal departments, commissions or common carriers of underground, surface or overhead gas, oil, electrical, steam, pipes, conduits, cables, fire alarm boxes, police call boxes, traffic signals, hydrants, towers and other similar equipment and accessories in connection therewith, by public utility or municipal departments, commissions, or common carriers, for the public health or safety or general welfare.

UTILITY POLE - A structure that:

1) is owned or operated by:

- A. A public utility;
- B. A communications service provider;
- C. A municipality;
- D. An electric membership corporation; or
- E. A rural electric cooperative; and,

2) is designed or used to:

- A. Carry lines, cables, or wires for telephony, cable television or electricity; or,
- B. Provide lighting; or,
- C. Provide signage.

The term does not include a wireless support structure or an electrical transmission tower.

UTILITY, PUBLIC (“UTILITY”) – Every corporation, company, partnership, limited liability company, individual, association of individuals, their lessees, trustees, or receivers appointed by court, that may own, operate, manager or control any plant or equipment within the state for the (1) conveyance of telegraph or telephone messages; (2) production, transmission, delivery, or furnishing of heat, light, water, or power; or (3) collection, treatment, purification, and disposal in a sanitary manner of liquid and solid waste, sewage, night soil, and industrial waste. The term does not include any of the foregoing facilities that a municipality may acquire, own or operate.

UTILITY POLE – A structure that:

1) is owned or operated by:

- A. A public utility;
- B. A communications service provider;
- C. A municipality;
- D. An electric membership corporation; or
- E. A rural electric cooperative; and,

2) is designed and used to:

- A. Carry lines, cables, or wires for telephony, cable television or electricity; or,
- B. Provide lighting.

The term does not include a wireless support structure or an electrical transmission tower.

V

VACATION HOME/VACATION RENTAL/HOLIDAY HOME/HOLIDAY APARTMENT/TOURIST HOME – The renting of a single-family home, duplex, apartment, cottage, condominium, villa, townhome or other similar dwelling on a short-term basis (less than 30 days), normally, nightly or weekly, to tourists and/or transients as an alternative to a hotel, motel bed & breakfast or resort. The property is generally fully furnished. The owner/operator does not utilize the facility as their primary residence.

VARIANCE - A modification of the specific requirements of this Ordinance granted by the Board in accordance with the terms of this Ordinance for the purpose of assuring that no property, because of special circumstances applicable to it, shall be deprived of privileges commonly enjoyed by other properties in the same vicinity and District.

VARIANCE, DEVELOPMENT STANDARDS - A specific approval granted by the Board of Zoning Appeals in the manner prescribed by this Ordinance, to deviate from the development standards (such as height, bulk, area) that this Ordinance otherwise prescribes.

VEHICLE – Anything or unit designed for transporting people or goods, over land or roads; vehicles shall include, but are not limited to, Class I and Class II vehicles, trailers, carts and recreational vehicles.

VEHICLE, CLASS I - Any non-commercial vehicle under 26,000 pounds primarily designed and used for private passenger use. These vehicles include passenger cars, light trucks, SUV, etc.

VEHICLE, CLASS II - Any other type of non-commercial vehicle under 26,000 pounds not covered by a Class I Vehicle. These vehicles could include trailers, boats, medium trucks, small box van, etc.

VEHICLE, COMMERCIAL - Any motor vehicle used or designed: (a) for use in pulling, towing, hauling, transporting, or (b) as a temporary or permanent base, platform, or support for equipment, machinery, materials or other goods (including but not limited to stake body trucks, dump trucks, trucks or trailers having dual rear wheels or more than two (2) axles, semi-trailer tractors, semi-trailers and trailers having dual rear wheels or more than one (1) axle or having an overall length of more than twelve (12) feet; (c) passenger vehicles marked by signage, logos or commercial messages. This definition does not apply to motor vehicles which serve as a source of transportation for an individual residing at the premises where the vehicle is stored or parked on a regular basis and is not used in any commercial activity.

VEHICLE, DISABLED – A Class I or II vehicle that is not operable.

VETERINARY CLINIC/ HOSPITAL - A place used for the care, grooming, diagnosis and treatment of sick, ailing, infirm or injured animals, and those who are in need of medical or surgical attention, and may include overnight accommodations on the premises for treatment, observation and recuperation.

VIBRATION - Oscillatory motion transmitted through the ground.

VICINITY MAP - A drawing located on a plat which shows by dimensions or other means, the relationship of the proposed subdivision or use to other nearby developments or landmarks and community facilities and services within County in order to better locate and orient the area in question.

VISION CLEARANCE AREA - A triangular space at the intersection of any two right-of-way lines (street and street, street and alley) or street and driveway, which is free of any kind of obstruction of vision between certain heights above the established grade, determined by a diagonal line connecting two points measured at a certain distance from the intersection along each right-of-way line.

W

WAIVER - A specific approval granted by the Area Plan Commission in the manner prescribed by the Subdivision Control Ordinance, to deviate from the standards that that Ordinance otherwise prescribes.

WALKWAY/BIKEWAY - A dedicated public way for pedestrian or bike use, whether along the side of a road or not.

WAREHOUSE - A building specially designed for receipt, storage, shipping and handling of goods. These facilities are regularly staffed with employees to manage a company's inventory.

WATER AND SEWAGE DISTRIBUTION AND PUMPING FACILITIES – Infrastructure solely intended for the purpose of supplying potable water and fire protection. This includes the water service pipe, the water distribution pipes and the necessary connecting pipes, fittings, control valves, and all appurtenances in or adjacent to the building or premises.

WATER PARK -An amusement park whose attractions include slides, fountains, and other recreational settings involving water.

WATER, PRIVATE - A water supply system, which is not constructed, installed, maintained, operated or owned by a municipality, taxing district established for the purpose or a utility under the jurisdiction of the Indiana Utility Regulatory Commission.

WATER, PUBLIC - A water supply system, which is constructed, installed, maintained, operated and owned by a municipality, taxing district established for that purpose or a utility under the jurisdiction of the Utility Regulatory Commission of Indiana.

WATERCOURSE - A permanent stream, intermittent stream, river, brook, creek, channel or ditch for water, whether natural or man-made.

WECS PROJECT – A collection of multiple WECS (as defined) as specified in the application for an Improvement Location Permit pursuant to Chapter 7.11 of this Ordinance.

WECS TOWER – The support structure to which the nacelle and rotor are attached, free standing or guyed structure that supports a wind turbine generator.

“WECS” WIND ENERGY CONVERSION SYSTEM – All necessary devices that together convert wind energy into electricity and deliver that electricity to a utility’s transmission lines, including but not limited to the rotor, nacelle, generator, WECS Tower, electrical components, WECS foundation, transformer, and electrical cabling from the WECS Tower, Substation, meteorological towers, communications facilities and other required facilities and equipment, as related to the WECS Project.

- A.) **COMMERCIAL WECS** – A Wind Energy Conversion System constructed on the property of another by a company or corporation or other entity, whose general intent is to capture wind energy and place it on the electrical grid for resale to a public utility. Any WECS designed to generate 40KW in total name plate generating capacity regardless of tower height.
- B.) **MICRO WECS** – a very small Wind Energy Conversion System designed to provide electric power to a home or other local site for use by the owner.
- C.) **NON-COMMERCIAL WECS** – A Wind Energy Conversion System that is generally smaller than a Commercial WECS and the primary purpose is to collect wind energy for the purpose of supplying energy to the owners, such as a business, school or factory.

WELDING SHOP – A facility where metals are joined by applying heat, sometimes with pressure and sometimes with an intermediate or filler metal having a high melting point.

WETLAND - Those areas that are inundated or saturated by surface or ground water at a frequency and duration sufficient to support, and that under normal circumstances do support, a prevalence of vegetation typically adapted for life in saturated soil conditions, or as otherwise defined by the U.S. Army Corps of Engineers.

WHOLESALE BUSINESS – An establishment or place of business primarily engaged in selling and/or distributing merchandise to retailers; to industrial, commercial, institutional, or professional business users, or to other wholesalers; or acting as agents or brokers and buying merchandise for, or selling merchandise to, such individuals or companies.

WILDLIFE PRESERVE - An area maintained in a natural state for the preservation of both animal and plant life.

WIND ENERGY CONVERSIONS SYSTEM (WECS) PROJECT – An individual or multiple WECS covered under a single Improvement Location Permit application pursuant to Chapter 7, Section 7.11 of this Ordinance including all other facilities, equipment and infrastructure supporting WECS installations.

WIND ENERGY CONVERSIONS SYSTEM (WECS) PROJECT DEVELOPER – The primary entity responsible for development of a WECS Project’s plans, installation and launch.

WIND ENERGY CONVERSIONS SYSTEM (WECS) PROJECT OPERATOR – The primary entity responsible for a WECS Projects ongoing operations.

WIND ENERGY CONVERSIONS SYSTEM (WECS) PROJECT OWNER – The entity(ies) which have ownership or legal control of any property within a WECS project area.

WIND ENERGY CONVERSION SYSTEM TOWER (WECS TOWER) – The support structure to which the nacelle and rotor are attached, it can be a free standing or guyed structure that supports a wind turbine generator.

WIND ENERGY CONVERSION SYSTEM TURBINE (WECS TURBINE) – A WEC Tower and Wind Power Device used in combination to produce electricity or mechanical energy from moving air.

WIND ENERGY CONVERSION TURBINE HEIGHT – The vertical distance measured from the average grade at the base of the WEC Tower to the peak of the WPD when the WPD Blade is at its highest point.

WIND ENERGY CONVERSION SYSTEM (WECS) – All necessary devices, equipment and facilities that together convert wind energy into electricity and which have the means to transport the generated electricity to a targeted source. These systems may include, but also are not limited to, the rotor, nacelle, generator, WEC Turbine, electrical components, WEC Tower foundation, transformer, electrical cabling from the WEC Turbine, to any utility substation,

meteorological tower, communication's facility or other required facilities and equipment directly related to the process of converting and moving the electricity converted from wind.

- A.) COMMERCIAL WECS – A WECS project constructed on the property of another by a company or corporation or other entity, whose primary purpose is to capture wind energy and place it on the electrical grid for resale to a public utility; also, any WECS designed to generate 40KW in total name plate generating capacity regardless of tower height.
- B.) MICRO WECS – A Wind Energy Conversion System designed to provide electric power to a home or other local site for use by the owner and which utilizes a WECS Turbine with a height of sixty (60) feet or less.
- C.) NON-COMMERCIAL WECS – An on-site Wind Energy Conversion System designed to provide electric power to a commercial, institutional, industrial or governmental facility or complex and which utilizes a WECS Turbine of more than sixty (60) feet but less than two hundred (200) feet in height.

WIND ENERGY (POWER) PROJECT, COMMERCIAL: A system of related wind energy conversion devices constructed by a company, corporation or other entity, whose general intent is to capture wind energy and place it on the electrical grid for resale to a public or government owned utility.

WIND POWER DEVICE (WPD) – A device, including a windmill or a wind turbine, that is designed to use the kinetic energy of moving air to provide mechanical energy or to produce electricity.

WINERY – An agricultural processing facility for the commercial purpose of processing grapes, other fruit products, or vegetables to produce wine or similar spirits. Processing includes wholesale sales, crushing, fermenting, blending, aging, storage, bottling, administrative office functions, for the winery, and warehousing. Retail sales and tasting facilities of wine and related promotional items may be permitted as part of the winery operations.

WIRELESS COMMUNICATIONS SERVICE – Services, whether mobile or at a fixed location, that are provided using wireless facilities through a licensed or unlicensed spectrum.

WIRELESS EQUIPMENT COMPOUND (when applied to a wireless communication site) - The area that surrounds or is near the base of a wireless support structure and encloses a wireless facility.

WIRELESS FACILITY - A set of equipment and network components that are owned & operated by a communication service provider; and, necessary to provide wireless communications service. The term does not include a wireless support structure.

WIRELESS FACILITY, COMMUNICATIONS – A wireless support structure and wireless equipment compound other than small cell or micro facilities.

WIRELESS FACILITY, MICRO – A small cell facility to which both of the following apply:

- 1) The small cell facility is not larger in dimension than:
 - A. Twenty-four (24) inches in length;
 - B. Fifteen (15) inches in width; and,
 - C. Twelve (12) inches in height.
- 2) If the small cell facility has an exterior antenna, the exterior antenna is no longer than eleven (11) inches.

WIRELESS FACILITY, SMALL CELL – A Small Cell Facility is defined as:

- 1) A personal wireless service facility (as defined by the Federal Telecommunications Act of 1996 as in effect on July 1, 2015); or,
- 2) A wireless facility that satisfies the following requirements:
 - A. Each antenna, including exposed elements, has a volume of six (6) cubic feet or less; and,
 - B. The primary equipment enclosure located with the facility has a volume of twenty-eight (28) cubic feet or less.

Note: The volume of the primary equipment enclosure does not include the following equipment that is located outside the primary equipment enclosure:

- 1) Electric meters
- 2) Concealment equipment
- 3) Telecommunications demarcation boxes
- 4) Ground based enclosures
- 5) Back-up power systems
- 6) Grounding equipment
- 7) Power transfer switches
- 8) Cut-off switches

WIRELESS SUPPORT STRUCTURE - A freestanding structure designed to support components of a wireless facility. The term does not include a utility pole or an electrical transmission tower.

WIRELESS SUPPORT STRUCTURE – A free standing structure designed to support or capable of supporting wireless facilities. The term does not include a utility pole or an electrical transmission tower.

WIRELESS SUPPORT STRUCTURE, HEIGHT OF - The vertical distance measured from the average ground level of the area within the base of the tower, to the highest point on a communications support structure, excluding antennas mounted on the tower.

WIRELESS SUPPORT STRUCTURE, MONOPOLE - A communication support structure consisting of a single pole, constructed without guy wires and ground anchors.

WIRELESS SUPPORT STRUCTURE, SUBSTANTIAL MODIFICATION – Modification of a wireless support structure in a manner that:

- 1) Increases the height of the structure by the greater of:
 - A. Ten percent (10%) of the original height of the wireless support structure; or
 - B. Twenty (20) feet;
- 2) Adds an appurtenance to the wireless support structure that protrudes horizontally from the wireless support structure more than the greater of:
 - A. Twenty (20) feet; or,
 - B. The width of the wireless support structure at the location of the appurtenance; or
- 3) Increases the square footage of the equipment compound in which the wireless facility is located by more than two thousand five hundred (2,500) square feet.

Note: The term does not include:

- 1) Increasing the height of a wireless support structure to avoid interfering with an existing antenna
- 2) Increasing the diameter or area of a wireless support structure to:
 - A. Shelter an antenna from inclement weather; or,
 - B. Connect an antenna to the wireless support structure by cable.

Y

YARD - A space on the same lot with a principal building, open, unoccupied and unobstructed by structures, except as otherwise provided in this Ordinance.

YARD, FRONT - A yard extending across the full width of the lot unoccupied other than by steps, walks, terraces, driveways, lamp posts and similar structures, the depth of which is the least distance between the front lot line and the building line.

YARD, REAR - A yard extending across the full width of the lot between the rear of the principal building and the rear lot line and unoccupied other than by accessory buildings which do not occupy any required space, and/or by steps, walks, terraces, driveways, lamp posts and similar structures, the depth of which is the least distance between the rear lot line and the rear of such principal building.

YARD, SIDE A yard between the principal building and the side lot line, extending from the front yard or from the front lot line where no front yard is required, to the rear yard. The width of the required side yard is measured horizontally at 90° with the side lot line, from the nearest part of the principal building, except in cases where irregular or pie shaped lots are located, then the width of the required side yard shall be an average of the width of the area between the side lot line and the principal building measured horizontally at 90° with the side lot line.

YOUTH/JUVENILE DETENTION CENTER – A secure residential facility for young people, often termed juvenile delinquents, awaiting court hearings and/or placement in long-term care facilities and/or programs.

Z

ZONING - A police power measure, enacted by the legislative body of the County and the local governments, in which the County and incorporated towns are divided into districts or zones within which permitted and special uses are established as are regulations governing lot size, building bulk, placement, and other development standards. White County has an Area Plan Commission zoning designation.

ZONING DISTRICT - A section of the territory within the Jurisdiction of the White County Area Plan Commission for which uniform regulations governing the use, height, area, size, and intensity of use of buildings and land, and open spaces about buildings, are herein established in this ordinance.

ZONING INSPECTOR - The Administrator or the duly appointed administrative officer designated to administer this zoning Ordinance.

ZONING MAP, OFFICIAL - The legally adopted map showing the legally established boundaries or the zoning districts within the County as adopted by the County Commissioners.

ZONING PERMIT - A document issued by the Administrator authorizing the use of lots, structures, uses of land and structures, and the characteristics of the use.

ZOO, PETTING – A location which features a collection of farm animals, docile wild animals and gentle exotic animals, or some combination thereof, designed to allow people, primarily children, the opportunity to hold, pet and/or feed animals in a safe environment.

ZOO/ZOOLOGICAL GARDEN/ZOOLOGICAL PARK –A place where animals are kept in some type of confined manner and exhibited to the public. Animal study and breeding may also be active at the site.

DEFINITION APPENDIX A: WIRELESS COMMUNICATION SITE AND ACTIVITY CONSOLIDATED DEFINITIONS (this section is not intended to be all inclusive and has been included for ease of reference only). Any contradictions between this Appendix and the Definition's main body, the Definition's main body rules.

ANTENNA - Any system of wires, poles, rods, reflecting discs, or similar devices used for the transmission or reception of electromagnetic waves external to or attached to the exterior of any building or, for the purpose of wireless communication service, any communications equipment that transmits or receives electromagnetic radio signals used in the provision of wireless communications service.

BASE STATION - A station located at a specific site that is authorized to communicate with mobile stations. The term includes all radio transceivers, antennas, coaxial cables, power supplies, and other electronics associated with a station.

COLLOCATION – The placement or installation of a wireless facility on existing structures that include a wireless facility or a wireless support structure, including water towers and other buildings or structures.

COMMUNICATIONS SERVICE PROVIDER – A person or entity that offers communications service to customers in Indiana, without regard to the technology or medium used by the person or entity to provide the communications service. This term includes a provider of commercial mobile service as defined in 47 U.S.C. 332.

FACILITY, WIRELESS - A set of equipment and network components necessary to provide wireless communications service. The term does not include a wireless support structure.

“SUBSTANTIAL” MODIFICATION (as it pertains to a wireless support structure) – A modification of a wireless support structure by the greater of: 1) ten percent (10%) of the original height of the wireless support structure or 2) twenty (20) feet; or, addition of an appurtenance to the wireless support structure that protrudes horizontally from the wireless support structure more than the greater of: 1) twenty feet or 2) the width of the wireless support structure at the location of the appurtenance or 3) increases the square footage of the equipment compound in which the wireless facility is located by more than two thousand five hundred (2,500) feet. The term does not include increasing the height of a wireless support structure to avoid interfering with an existing antenna or increasing the diameter or area of a wireless support structure to shelter an antenna from inclement weather or connect an antenna to a wireless support structure by cable.

UTILITY, MUNICIPAL – Every utility owned or operated by a municipality

UTILITY, PUBLIC (“UTILITY”) – every corporation, company, partnership, limited liability company, individual, association of individuals, their lessees, trustees, or receivers appointed by court, that may own, operate, manager or control any plant or equipment within the state for the (1) conveyance of telegraph or telephone messages; (2) production, transmission, delivery, or furnishing of heat, light, water, or power; or (3) collection, treatment, purification, and disposal in a sanitary manner of liquid and solid waste, sewage, night soil, and industrial waste. The term does not include any of the foregoing facilities that a municipality may acquire, own or operate.

UTILITY POLE – a structure that:

1) is owned or operated by:

- A. A public utility
- B. A communications service provider;
- C. A municipality;
- D. An electric membership corporation; or
- E. A rural electric cooperative; and,

2) is designed and used to:

- A. Carry lines, cables, or wires for telephony, cable television or electricity; or,
- B. Provide lighting.

The term does not include a wireless support structure or an electrical transmission tower.

WIRELESS EQUIPMENT COMPOUND (when applied to a wireless communication site) - The area that surrounds or is near the base of a wireless support structure and encloses a wireless facility.

WIRELESS FACILITY - A set of equipment and network components necessary to provide wireless communications service. The term does not include a wireless support structure.

WIRELESS SUPPORT STRUCTURE - a freestanding structure designed to support components of a wireless facility. The term does not include a utility pole or an electrical transmission tower.

WIRELESS SUPPORT STRUCTURE, HEIGHT OF - The vertical distance measured from the average ground level of the area within the base of the tower, to the highest point on a communications support structure, excluding antennas mounted on the tower.

WIRELESS SUPPORT STRUCTURE, MONOPOLE - A communication support structure consisting of a single pole, constructed without guy wires and ground anchors.

APPENDIX A: OFFICIAL SCHEDULE OF USES

USE	CFO	L-1	A-1	A-2	RR	R-1	R-2	R-3	R-4	B-1	B-2	B-3	B-4	B-5	I-1	I-2	I-3	AED
Adult Entertainment Business											S							
Agri Bio Production				P												P	P	
Agricultural Industry			S	P													P	
Agricultural Produce Business, Permanent			P	S	P					P	P	P	P					
Agricultural Produce Business, Seasonal	P		P	A	P					P	P	P	P					
Agricultural Produce Sales, Portable			T		T					T	T	T	T		T	T		P
Agricultural Research Firm			S	P											P		P	
Agricultural Roadside Stand	A	A	A	A	A	A	A			A	A	A	A					A
Agriculture	P		P	P	P													
Agriculture Service & Support			P	P											P	P		
Airport			S	S											S	S		
Amphitheater																		P
Amusement Park																		P
Amusement Park Offices										P	P	P	P	P	P			P
Animal Sanctuary				P														P
Animal Shelter			P	P														
Antennae, Amateur Radio	A	A	A	A	A	A	A	A	A	A	A	A	A	A	A	A		A
Antennae, Radio			A	A								A			A	A		A
Antennae, Television	A	A	A	A	A	A	A	A	A	A	A	A	A	A	A	A		A
Apartment		A	A		A		A	A		A			P					
Apartment, Accessory		A	A			A	A	A										
Apartment, Micro-Unit										P			P					

Pb-Permitted on property abutting RR ROW

Legend:

Ai-Accessory Use-Institutions Only

LP – Permitted on any floor level excluding the ground floor

P-Allowed Use
S-Special Exception Use
A-Accessory Use

T-Temporary Use
Ti-Temporary Use-Institutions Only
Blank-Prohibited Use

USE	CFO	L-1	A-1	A-2	RR	R-1	R-2	R-3	R-4	B-1	B-2	B-3	B-4	B-5	I-1	I-2	I-3	AED
Arcade			A							P	P	P	P					P
Asphalt Plant (manufacturing)			S													S		
Assisted Living Facility	P				P	P	P	P										
Auction, Sale	T	T	T	T	T	T	T	T	T	T	T	T	T	T	T	T		T
Auction Arena or Sales Barn (for livestock)			S	P														
Auction Arena or Sales Yard (excluding livestock)			P								P	P			P			
Automated Teller Machine (ATM)			A							P	P	P	P	P	P	P		P
Automobile Convenience Mart										P	P	P	P		P	P		
Automobile Parts/Supply Retail Establishment										P	P	P	P		P			
Automobile Rental/Leasing Establishment											P	P	P		P			
Automobile Sales			T								P	P	P					
Automobile Service, Major											P	P			P			
Automobile Service, Minor			P							P	P	P	P		P			
Bait Sales	P									P	P	P	P					P
Bake Sale	T	T	T	T	T	T	T	T	T	T	T	T	T	T	T	T		T
Bakery or Delicatessen										P	P	P	P	P				P
Ballroom																		P
Bank										P	P	P	P	P				
Banquet Hall			P							P	P	P	P	P				P
Bathhouse	A	A	A	A	A	A	A	A	A									A
Battery, Storage Field, Wind or Solar			P													P		
Battery, Storage Retrofit, Wind or Solar			P													P		
Batting Cages, Commercial											P	P						P

Pb-Permitted on property abutting RR ROW

Legend:

Ai-Accessory Use-Institutions Only

LP - Permitted on any floor level excluding the ground floor

P-Allowed Use

S-Special Exception Use

A-Accessory Use

T-Temporary Use

Ti-Temporary Use-Institutions Only

Blank-Prohibited Use

USE	CFO	L-1	A-1	A-2	RR	R-1	R-2	R-3	R-4	B-1	B-2	B-3	B-4	B-5	I-1	I-2	I-3	AED
Bazaar	T	T	T		T	T	T	T	T	T	T	T	T	T				T
Bed and Breakfast	P	P	S		S	S	P	P										P
Bio-Medicine Facility				P												P	P	
Boarding House/Rooming House			S		S	S	P	P										
Boat Sales and Service											P	P						P
Boat Storage, Commercial		S	P	P							P	P			P	P		P
Body Piercing										P	P	P	P					P
Botanical Garden/Botanic Garden/Botanical Institution			P															P
Bottled Gas Storage and Distribution Yard											S	S			S	S		
Bowling Alley										P	P	P	P					P
Brew Pub										P	P	P	P					
Brewery																P		
Brewery, Craft																P		
Brewery, Micro											P	P	P		P	P		
Building, Agency or Department		P	P		P	P	P	P	P	P	P	P	P	P	P			
Bunkhouse			A	A														
Bus Garage			S							S	P	P	S		P			
Bus Station, Passenger										S	P	P	S		P			
Cabana	P	P	P		P	P	P	P	P									P
Cabin	P	P	P															P
Campground	S	S	S									S			S			P
Car Wash										P	P	P	P	P				
Caretaker Home	A	A	A	A	A		A	A	A									

Pb-Permitted on property abutting RR ROW

Legend:

Ai-Accessory Use-Institutions Only

LP – Permitted on any floor level excluding the ground floor

P-Allowed Use

S-Special Exception Use

A-Accessory Use

T-Temporary Use

Ti-Temporary Use-Institutions Only

Blank-Prohibited Use

USE	CFO	L-1	A-1	A-2	RR	R-1	R-2	R-3	R-4	B-1	B-2	B-3	B-4	B-5	I-1	I-2	I-3	AED
Carnival	T	T	T		T	T	T	T		T	T	T	T					P
Carport	A	A	A	A	A	A	A	A	A				A					A
Casino																		P
Catering Service			P		P					P	P	P	P	P				P
Cemetery			P							-	P		-	P				
Child Care Center		P	P							P	P	P	P	P				
Child Care Home	P	P	P	P		P	P	P	P									
Child Care House	A	A	A	A	A	A	A	A	A									
Children's Play Equipment	A	A	A	A	A	A	A	A	A	A	A	A	A	A				A
Christmas Tree Sales	Ti	Ti	T	T	Ti	Ti	Ti	Ti	Ti	T	T	T	T		T	T		T
Circus	Ti	Ti	T		Ti	Ti	Ti	Ti	Ti	T	T	T	T					P
Club or Lodge, Private			P							P	P	P	P					
Commissary										P	P	P	P					
Community Center			P			P	P	P	P	P	P	P	P	P				
Community Commons	P	P				P	P	P	P	P	P		P					P
Concessionaire (See Street Vendor and Peddler for similar uses)	A	A	A		Ai	Ai	Ai	Ai	Ai	A	A	A	A					P
Concrete or Cement Batching Plant, Permanent															P	P		
Concrete or Cement Batching Plant, Portable	T	T	T	T	T	T	T	T	T	T	T	T	T	T	T	T		T
Conference Center/Meeting Hall		P	P		A	P	P	P		P	P	P	P	P	A	A		P
Conference Facility										P	P	P	P					P
Confined Feeding Operation				P														
Construction Yard	T	T	T	T	T	T	T	T	T	T	T	T	T	T	T	T		T
Construction, Heavy Contractors			S	S							S	S			P	P		

Pb-Permitted on property abutting RR ROW

Legend:

Ai-Accessory Use-Institutions Only

LP - Permitted on any floor level excluding the ground floor

P-Allowed Use
S-Special Exception Use
A-Accessory Use

T-Temporary Use
Ti-Temporary Use-Institutions Only
Blank-Prohibited Use

USE	CFO	L-1	A-1	A-2	RR	R-1	R-2	R-3	R-4	B-1	B-2	B-3	B-4	B-5	I-1	I-2	I-3	AED
Convenience Store, Neighborhood								P		P	P	P	P					
Convenience Store, Regional											P	P			P			
Convention Center/Exhibition Hall											P	P			P			
Correctional/Penal Facility			S												S			
Cottage/Summer Home		P	P			P	P		P									
Crematory											P	P	P		P			
Day Care Center, Adult	P	P	P	P	P	P	P	P		P	P		P	P				
Digester, Aerobic or Anaerobic			A	P											A	P	P	
Distillery																P		
Distillery, Micro or Boutique											P	P	P		P	P		
Distribution Center			A								S	P			P	P	P	
Driving Range			S		S		S				S	S						P
Dwelling, Farm			P	P	P													
Dwelling, Multi-Family								P										
Dwelling, Single-Family	P	P	P	P	P	P	P	P	P				LP					
Dwelling, Student/Fraternity/Sorority								P										
Dwelling, Subordinate		P	P		P		P											
Dwelling, Two-Family	P	P					P	P					LP					
Educational Facility, Other			P			P	P	P		P	P	P	P	P				
Educational Facility, Private			P			P	P	P		P	P	P	P	P				
Educational Facility, Public			P			P	P	P		P	P	P	P	P				
Electric Vehicle Charging Station, Private (EVCS Private)	A	A	A	A	A	A	A	A	A	A	A	A	A	A	A	A	A	A
Electric Vehicle Charging Station, Public (EVCS Public)		S	S							P	P	P	P	P	P	P	P	P

Pb-Permitted on property abutting RR ROW

Legend:

Ai-Accessory Use-Institutions Only

LP – Permitted on any floor level excluding the ground floor

P-Allowed Use

T-Temporary Use

S-Special Exception Use

Ti-Temporary Use-Institutions Only

A-Accessory Use

Blank-Prohibited Use

USE	CFO	L-1	A-1	A-2	RR	R-1	R-2	R-3	R-4	B-1	B-2	B-3	B-4	B-5	I-1	I-2	I-3	AED
Engine Repair, Large (See Automobile Service, Major)																		
Engine Repair, Small		P									P				P			
Entertainment Facility, Commercial										P	P	P	P					P
Equipment Sales and Leasing											P	P			P			
Ethanol or other similar Bio-processing Plant				S												S		
Event, Barn			S															P
Event, Government		T	T	T	T	T	T	T	T	T	T	T	T		T	T		P
Event, Special	T	Ti	T	T	Ti	Ti	Ti	Ti	Ti	T	T	T	T		T	T		T
Event, Sporting	T	Ti	T	T	Ti	Ti	Ti	Ti	Ti	T	T	T	T		T	T		T
Explosives, Use or Storage																S		
Fairgrounds			P															P
Farm Chemical/Fertilizer Supplier			P	P											P			
Farming, Micro		P				P	P	P	P									
Festival	T	T	T		T	T	T	T	T	T	T	T	T	T	T	T		T
Fire, Police, Postal Stations										P	P	P	P		P			
Fireworks Sales										P	P	P	P		P	P		
Flea Market	Ti	Ti	T		Ti	Ti	Ti	Ti	Ti	P	P	P	P		P			P
Funeral Home or Mortuary										P	P	P	P					
Garage, Attached	A	A	A	A	A	A	A	A	A	A			A					A
Garage, Detached	P	P	P	P	P	P	P	P	P									P
Gasoline Service Station										P	P	P	P		P			P
Go-Kart Facility																		P
Golf Course			P		P		P											P

Pb-Permitted on property abutting RR ROW

Legend:

Ai-Accessory Use-Institutions Only

LP – Permitted on any floor level excluding the ground floor

P-Allowed Use

S-Special Exception Use

A-Accessory Use

T-Temporary Use

Ti-Temporary Use-Institutions Only

Blank-Prohibited Use

USE	CFO	L-1	A-1	A-2	RR	R-1	R-2	R-3	R-4	B-1	B-2	B-3	B-4	B-5	I-1	I-2	I-3	AED
Government Building		P	P		P	P	P	P	P	P	P	P	P	P	P			
Grain Elevator			P	P												P		
Grandstand			A		A	A	A	A	A		A	A			A			A
Greenhouse, Commercial			P	P							P	P		P	P			
Greenhouse, Non-Commercial	A	A	A	A	A	A	A	A	A									A
Grocery Store or Supermarket										P	P	P	P					
Group Home								P		P	P		P	P				
Guard Shacks	A	A	A	A	A	A	A	A	A		A	A			A	A		A
Guest House		P																
Gun Sales			P							P	P		P					
Gun Smith			P							P	P		P					
Hatchery, Commercial	S		P	P														
Hazardous Waste Landfill/Facility																S		
Health and Fitness Center								P		P	P	P	P	P				P
Health Center, Public										P	P	P	P	P				A
Heliport			S	S							S	S			S	S	S	
Home Occupation	A	A	A	A	A	A	A	A	A	A			A					A
Hospital										S	P	P			P			
Hotel										P	P	P	P					P
Incinerator			S	P											S	P		
Industrial Waste Facility																S	Pb	
Information Center, Visitor/Tourist	P	P						P		P	P	P	P	P				P
Integrated Center		S									P	P						

Pb-Permitted on property abutting RR ROW

Legend:

Ai-Accessory Use-Institutions Only

LP – Permitted on any floor level excluding the ground floor

P-Allowed Use

S-Special Exception Use

A-Accessory Use

T-Temporary Use

Ti-Temporary Use-Institutions Only

Blank-Prohibited Use

USE	CFO	L-1	A-1	A-2	RR	R-1	R-2	R-3	R-4	B-1	B-2	B-3	B-4	B-5	I-1	I-2	I-3	AED
Internet Selling Establishment/E-bay Store										P	P	P	P	P				
Jail			P								P				P			
Junkyard			S													S		
Kennel, Commercial			P	P														
Kennel, Private			P	P														
Laboratory, Commercial			P								P	P		P	P			
Laboratory, Medical or Dental											P	P		P	P			
Laboratory, Research Activity and Testing											P	P		P	P	P	P	
Land Use Amenity	A	A	A	A	A	A	A	A	A	A	A	A	A	A	A	A	A	A
Landfill																S		
Landfill, Sanitary																S		
Landscape Contractor			P								P	P			P	P		
Laundry Facility, Self Service			A					A	A	P	P	P	P	P				A
Laundry or Dry Cleaning Facility										P	P		P					
Library		P	P		P	P	P	P	P	P	P	P	P	P	P			
Manufactured Home	P	P	P	P	P	P	P	P	P				S					
Manufactured Home Office, Permanent			A	A							S	S		S	P	P		
Manufactured Home Park or Subdivision									P									
Manufactured Home Park or Subdivision, Existing									P									
Manufactured Home Park or Subdivision, Expansion									P									
Manufactured/Mobile Home/RV Dwelling	T	T	T	T	T	T	T	T	T	T			T					
Manufacturing, Extractive – Non-Urban	P	P	P	P	P	P	P	P	P	P	P	P	P	P	P	P	P	P

Pb-Permitted on property abutting RR ROW

Legend:

Ai-Accessory Use-Institutions Only

LP – Permitted on any floor level excluding the ground floor

P-Allowed Use

S-Special Exception Use

A-Accessory Use

T-Temporary Use

Ti-Temporary Use-Institutions Only

Blank-Prohibited Use

USE	CFO	L-1	A-1	A-2	RR	R-1	R-2	R-3	R-4	B-1	B-2	B-3	B-4	B-5	I-1	I-2	I-3	AED
Manufacturing, Extractive – Urban																S		
Manufacturing, Heavy																P	Pb	
Manufacturing, Light															P	P	P	
Marina											P							P
Massage Parlor										P	P	P	P	P				
Mechanical Rides or Attractions	Ti	Ti	T		Ti	Ti	Ti	Ti	Ti	P	P	P	P					P
Medical Clinic							P	P		P	P	P	P	P				
Medical Emergency/Immediate Care Facility										P	P	P	P					
Medical Office										P	P		P	P				
Medical, Mental Health Facility (or Psychiatric Hospital)										S	P	P	S		P			
Meteorological Tower			P	P							S	S			S	S		
Miniature Golf Facility											P	P		P				P
Model Home or Apartment	P	P	P		P	P	P	P	P									
Modular Home	P	P	P	P	P	P	P		P									
Motel											P	P						P
Motorcycle Sales										P	P	P	P		P			
Museum/Gallery		P	P		P	P	P	P	P	P	P	P	P	P	P			
Neighborhood Facility			S			S	S	S		S	S	S	S	S				
Newspaper Publishing										P	P	P	P		P			
Newspaper Stand										P	P	P	P	P	P	P		P
Non-profit/Charitable Organization	A	A	A		A	A	A	A	A	P	P		P	P				
Nursery, Horticultural			P	P							P	P		P	P			
Nursing Home								P		P	P		P	P				

Pb-Permitted on property abutting RR ROW

Legend:

Ai-Accessory Use-Institutions Only

LP – Permitted on any floor level excluding the ground floor

P-Allowed Use

S-Special Exception Use

A-Accessory Use

T-Temporary Use

Ti-Temporary Use-Institutions Only

Blank-Prohibited Use

USE	CFO	L-1	A-1	A-2	RR	R-1	R-2	R-3	R-4	B-1	B-2	B-3	B-4	B-5	I-1	I-2	I-3	AED
Office Building										P	P	P	P	P			P	
Office Research Park											P	P			P		P	
Orchard/Vineyard			P	P	P													
Park, Private	P	P	P		P	P	P	P	P	P	P	P	P	P	P	P		P
Park, Public	P	P	P		P	P	P	P	P		P	P		P				P
Parking Lot	A	A	P	P	A	A	A	P	P	P	P	P	P	P	P	P		P
Parking Lot, Event, Special	T	T	T	T	T	T	T	T	T	T	T	T	T	T	T	T		T
Parking Structure										P	P	P	P		P	P		P
Peddler (See Street Vendor and Concessionaire for similar uses)		T			T	T	T	T	T									
Personal/Professional Services (see definition for exclusions)										P	P	P	P	P				P
Pet Grooming, domestic (Pet Spa)			S								P	P		P	P			
Printing, lithographing, publishing, or photography										P	P	P	P		P			P
Race Track			P															P
Radio, TV, Music Studio/Station	P	A	A		A	A	A	A	A	P	P	P	P	P				
Railroad Facilities			S							S	S	P	S		P	P	Pb	
Raising and Breeding of Non-Farm Fowl or Animals, Commercial			P	P	P													
Recreational Facility, Indoor			A				S	S		P	P	P	P		P			P
Recreational Facility, Outdoor,			A				S	S		P	P	P	P		P			P
Recreational Vehicle Park	S	S	S									P			S			P
Recreational Vehicle Sales											P	P			P			
Recycling Facility																S		
Recycling Satellite, Private			P								P	P			P	P		P
Recycling Satellite, Public			P								P	P			P	P		P

Pb-Permitted on property abutting RR ROW

Legend:

Ai-Accessory Use-Institutions Only

LP – Permitted on any floor level excluding the ground floor

P-Allowed Use

S-Special Exception Use

A-Accessory Use

T-Temporary Use

Ti-Temporary Use-Institutions Only

Blank-Prohibited Use

USE	CFO	L-1	A-1	A-2	RR	R-1	R-2	R-3	R-4	B-1	B-2	B-3	B-4	B-5	I-1	I-2	I-3	AED
Religious Institution		P	P		P	P	P	P		P	P	P	P	P				
Rendering Plant				P												P	P	
Residential Subdivision		P			P	P	P	P	P									
Resort											P							P
Restaurant										P	P	P	P					P
Restaurant, Drive-Through										P	P	P	P					P
Retail Establishment (0 to 99,999 GSF)								S		P	P	P	P					P
Retail Establishment (100,000 GSF or more)											P	P						P
Retail, Shopping Center/Shopping Mall/Strip Mall (See Integrated Center)																		
Retail, Temporary	Ti	Ti	Ti		Ti	Ti	Ti	Ti		T	T	T	T		T	T		T
Retreat			P															
Sales Office/Dwelling Unit	T	T	T		T	T	T	T	T									
Sawmill			T	T													P	
Scrap Metal Yard																	S	
Sewage Treatment Plant, Private		S	S		S	S	S	S	S									
Shooting Range, Indoor											S	S			S	S		
Shooting Range, Outdoor			S	S												S		
Street Vendor (See Concessionaire and Peddler for similar uses)		Ti	Ti		Ti	Ti	Ti	Ti	Ti	T	T	T	T	T	T	T	T	T
Slaughter House			A	A											S	S		
Social Services										P	P		P	P				
Solar Energy System, Commercial (CSE)			P	P											P	P		
Solar Energy System, Individual (ISE)	A	A	A	A	A	A	A	A	A	A	A	A	A	A	A	A	A	A
Solar Energy System, Shared (SSE)	P/A	P/A	P/A	P/A	P/A	P/A	P/A	P/A	P/A	P/A	P/A	P/A	P/A	P/A	P/A	P/A	P/A	P/A

Pb-Permitted on property abutting RR ROW

Legend:

Ai-Accessory Use-Institutions Only

LP - Permitted on any floor level excluding the ground floor

P-Allowed Use
S-Special Exception Use
A-Accessory Use

T-Temporary Use
Ti-Temporary Use-Institutions Only
Blank-Prohibited Use

USE	CFO	L-1	A-1	A-2	RR	R-1	R-2	R-3	R-4	B-1	B-2	B-3	B-4	B-5	I-1	I-2	I-3	AED
Sporting Event (for profit)	Ti	Ti	T		Ti	Ti	Ti	Ti		T	T	T	T		T	T		T
Stable or Boarding, Commercial			P	P	S													
Stable or Boarding, Private			P	P	P													
Stadium, Coliseum, Athletic Field - Commercial											S				P			P
Stockyard			P	P														
Storage Facility, Self Service											P	P			P	P		
Storage Tank, Fuel (Commercial)			A	A							A	A			A	P		A
Storage Tank, Fuel (Private)		A	A	A	A	A	A	A	A		A	A			A	A		A
Storage Tank, Gas (Commercial)			A	A							A	A			A	P		A
Storage Tank, Gas (Private)		A	A	A	A	A	A	A	A									A
Storage Tank, Oil																P		
Storage Tank, Water/Water Tower		P	P	A	P	P	P	P	P	P	P	P	P	P	P	A		A
Storage Yard			A	A								P			P	P		
Storage, Bulk															P	P		
Storage, Commercial										P	P	P	P	P	P	P		P
Storage, Outside/Outdoor											P	P				P		P
Storage, Personal	P	P	P	P	P	P	P	P	P									
Subdivision, Residential Major		P			P	P	P	P	P									
Subdivision, Business/Industrial										P	P	P	P		P	P		
Swimming Pool, Private	A	A	A	A	A	A	A	A	A									P
Tattoo Parlor										S	S	S						S
Tavern										P	P	P	P					P

Pb-Permitted on property abutting RR ROW

Legend:

Ai-Accessory Use-Institutions Only

LP – Permitted on any floor level excluding the ground floor

P-Allowed Use

S-Special Exception Use

A-Accessory Use

T-Temporary Use

Ti-Temporary Use-Institutions Only

Blank-Prohibited Use

USE	CFO	L-1	A-1	A-2	RR	R-1	R-2	R-3	R-4	B-1	B-2	B-3	B-4	B-5	I-1	I-2	I-3	AED
Taxi Cab Company											P	P						
Theater, Indoor											P	P	P					P
Theater, Outdoor	T	T	T		T	T	T	T	T	T	T	P/T	T		S/T	T		P/T
Therapeutic Horseback Riding/Equine-Assisted Activity/Adaptive Riding			P		P													
Ticket Booth																		P
Transfer Facility, Other															P	P	P	
Transfer Facility, Solid Waste																P		
Truck Freight Terminal															S		P	
Truck Stop											S	P			S	P		
Truck Wash			A	A							S	P			S	P		
Utility Facility, Public	P	P	P	P	P	P	P	P	P	P	P	P	P	P	P	P	P	P
Vacation Home/Vacation Rental/Holiday Home/Holiday Apartment/Tourist Home (VRBO)		S	S				S											P
Veterinary Clinic/Hospital			S								P	P		P	P			
Warehouse			A	A											P	P	P	
Water and Sewage Distribution and Pumping Facilities	P	P	P	P	P	P	P	P	P	P	P	P	P	P	P	P	P	P
Water Park	A	A	A		A	A	A	A	A	A	A	A	A	A	A	A		P
WECS – Commercial			P	P							S	S			S	S		
WECS – Micro	P	P	P	P	P	P	P	P	P	P	P	P	P	P	P	P		P
WECS – Non-commercial equal or less than 200 feet in height			P	P	P						S	S			S	S		S
WECS – Non-commercial greater than 200' in height			S	S	S						S	S			S	S		S
Welding Shop			A	A							P	P			P	P		A
Wholesale Business												P			P	P	P	
Winery			P								P	P			P			

Pb-Permitted on property abutting RR ROW

Legend:

Ai-Accessory Use-Institutions Only

LP – Permitted on any floor level excluding the ground floor

P-Allowed Use

S-Special Exception Use

A-Accessory Use

T-Temporary Use

Ti-Temporary Use-Institutions Only

Blank-Prohibited Use

USE	CFO	L-1	A-1	A-2	RR	R-1	R-2	R-3	R-4	B-1	B-2	B-3	B-4	B-5	I-1	I-2	I-3	AED
Wireless Facility, Communications			P	P	Ai	Ai	Ai	Ai			P	P		P	P	P	P	P
Wireless Facility, Micro	A	A	A	A	A	A	A	A	A	A	A	A	A	A	A	A	A	A
Wireless Facility, Small Cell	A	A	A	A	A	A	A	A	A	A	A	A	A	A	A	A	A	A
Youth/Juvenile Detention Center								P							P			
Zoo, Petting (Permanent)											P	P						P
Zoo, Petting (Temporary)			T							T	T	T	T		T	T		P
Zoo/Zoological Garden/Zoological Park																		P

Legend:

P-Allowed Use
 S-Special Exception Use
 A-Accessory Use

Ai-Accessory Use-Institutions Only

T-Temporary Use
 Ti-Temporary Use-Institutions Only
 Blank-Prohibited Use

Pb-Permitted on property abutting RR ROW

LP – Permitted on any floor level excluding the ground floor

Appendix B: Bulk Use Standards - Residential & Agricultural

Bulk Use Standards		Zoning District								
		CFO	L-1	A-1	A-2	RR	R-1	R-2	R-3	R-4
Minimum Lot Size (SQ FT)	Lot/Parcel Minimum w/sewer	65340	10000	43560	217800	21780	10000	10000	10000	10000 (B)
	Lot/Parcel Minimum w/o sewer	65340	43560	43560	217800	43560	43560	43560	43560	43560
Minimum Living Space (SQ FT)	Compact House/Dwelling Unit (First Floor)	Not Allowed	300	Not Allowed	Not Allowed	Not Allowed	300	300	Not Allowed	Not Allowed
Minimum Building Size (SQ FT)	Standard House/Dwelling Unit	900	900	900	900	900	900	900	900	900
Minimum Living Space (SQ FT)	Standard House/Dwelling Unit (First Floor)	600	600	600	600	600	600	600	600	20
Minimum Lot Width (FT)	Width (At Building Line)	150	60	150	500	150	80	60	60	0
Minimum Front Setback (FT)	Adjacent To A Public or Private Road	30	30	30	30	30	30	30	30	30
	Within A Subdivision	C	C	C	C	C	C	C	C	C
	From Waterside	30	30	30	30	30	30	30	30	30
Minimum Rear Setback (FT)	Principal Structure	20	20	20	20	20	20	20	20	20
	Accessory Structure	4	20	4	4	4	4	4	4	4
Minimum Side Setback (FT)	Principal or Accessory Structure	4	4	4	4	4	4	4	4	4
Maximum Structure Height (FT)	Principal Structure	35	35	35	35	35	35	35	75	35
	Accessory Structure	25	25	B	B	B	25	25	25	25
Maximum Lot Coverage	Principal & Accessory Structures (% of gross lot area)	None	60	None	None	60	60	60	60	60

Foot Notes:

- A For Manufactured Home Parks, As Required By The Area Plan Commission
- B There shall be no height limit provided that for every foot in height the structure is over 19', the side and rear setbacks shall increase one foot
- C In any major or minor, residential, business or industrial subdivision, any valid setbacks or other developmental standards incorporated on the recorded plat or within the covenants and restrictions apply. In all other cases, county setbacks and developmental standards apply
- D Subordinate Dwelling Units shall be subject to the same setbacks, height restrictions and size minimums as a Principal Structure.

Additional Foot Notes:

- 1 In the case of a legally nonconforming dwelling, the front setback requirement for the parcel shall be established by the distance from the property line or road rights-of-way, whichever is most restrictive, to the foundation of the building
- 2 Within any municipality or any recorded subdivision, each dwelling shall be allowed to add, modify or alter the dwelling utilizing a front setback equivalent to the closest front setback of the dwelling unit on any abutting lot, or one separated only by an alley, which would have a common front property line if extended, however, for any corner lot, the visibility clearance area must be honored
- 3 Any deck built on a property which has the waterside as its front lot line shall be allowed a zero front setback for a deck only
- 4 Any lot determined to be in a lake area which has a property line abutting a road shall require the applicable property line meet a 20' foot minimum setback
- 5 Compact Houses are only permitted on parcels of 5,000 square feet or less
- 6 Any lot or parcel impacted by a transfer of land related to a government taking or purchase or rights-of-way, shall retain conforming status and will have the developments standards applied to that lot or parcel, as configured at the time of the rights-of-way land transfer, adjusted to the level of the taking. Only those specific standards impacted the taking are subject to this adjustment.
- 7 In any residential or agricultural district, the property owner may utilize accessory structure setbacks for a garage, shed, personal storage building or other incidental structure in order that such structure be located in a manner which will preserve the maximum amount of lot area for future lot development.

Appendix B: Bulk Use Standards - Commercial & Industrial

Bulk Use Standard		Zoning District								
		B-1	B-2	B-3	B-4	B-5	I-1	I-2	I-3	AED
Minimum Lot Size (SQ FT)	Lot/Parcel Minimum w/sewer	5000	10000	25000	None	10000	25000	25000	130680	7500
	Lot/Parcel Minimum w/o sewer	130680	130680	130680	None	130680	130680	130680	130680	43560
Minimum Building Size (SQ FT)		None	None	None	None	None	None	None	30,000 (F)	None
Minimum Lot Width (FT)	Width (At Building Line)	50	70	125	0	70	250	250	250	50
Minimum Front Setback (FT)	Adjacent To A Public or Private Road	30	30	30	0	30	30	30	E	20
	Within A Subdivision	D	D	D	D	D	D	D	D	D
	From Waterside	30	30	30	0	30	30	30	E	0
Minimum Rear Setback (FT)	Principal Structure	20	20	20	0	20	20	20	E	20, A & G
	Accessory Structure	20	20	20	0	20	20	20	E	20, A & G
Minimum Side Setback (FT)	Principal or Accessory Structure	B	5	5	0	5	10	10	E	5, A & G
Maximum Structure Height (FT)	Principal Structure	45	45	45	45	45	55	55	55	45
	Accessory Structure	19	19	19	19	19	C	C	55	None
Maximum Lot Coverage	Principal & Accessory Structures (% of gross lot area)	90	80	80	100	80	None	None	None	None

Foot Notes:

- A There shall be no less than ten (10) feet between any structures
- B When adjoining a business or industrial district, the minimum setback shall be zero. When adjoining any other district, the minimum setback shall be equal to that of the adjoining district
- C There shall be no height limit provided that for every foot in height the structure is over 19', the side and rear setbacks shall increase one foot
- D In any major or minor, residential, business or industrial subdivision, any valid setbacks or other developmental standards incorporated on the recorded plat or within the covenants and restrictions apply. In all other cases, county setbacks and developmental standards apply
- E For additional setback requirements, refer to the White County Zoning Ordinance, Section 3.14
- F Applies to the ground floor level of the principal structure
- G Setback is waived in situations where a rear or side property line are subject to common ownership or which abutt an SFLECC property line.

Additional Foot Notes:

- 1 Any deck built on a property which has the waterside as its front lot line shall be allowed a zero front setback for a deck only
- 2 Any lot determined to be in a lake area which has a property line abutting a road shall require the applicable property line meet a 20' foot minimum setback

Amended: 08/21/23 Ordinance #23-08-21-02

Table C.1: Trees approved for planting along public rights-of-way and in locations where low maintenance, hardy species with high canopies are required

Botanic Name	Common Name	Height	Tree Category
<i>Acer campestre</i>	Hedge Maple	30'-40'	Ornamental
<i>Acer Freemanii</i>	Freeman Maple	50-60'	Shade
<i>Acer rubrum</i>	Red Maple	50-60'	Shade
<i>Acer saccharum</i>	Sugar Maple	50-70'	Shade
<i>Acer tataricum</i>	Tatarian Maple	20-25'	Ornamental
<i>Acer truncatum</i> x <i>acer platanoides</i>	Sunset Shantung Hybrid Maple	30-40'	Shade
<i>Carpinus betulus</i> 'Fastigiata'	Upright European Hornbeam	30-40'	Ornamental
<i>Carpinus caroliniana</i>	American Hornbeam	25-30'	Ornamental
<i>Celtis occidentalis</i>	Hackberry	50-75'	Shade
<i>Cercis canadensis</i>	Eastern Redbud	20-25'	Ornamental
<i>Cladrastis lutea</i>	Yellowwood	35-55'	Shade
<i>Crataegus crus-galli</i> var. <i>inermis</i>	Thornless Cockspur Hawthorn	15-25'	Ornamental
<i>Crataegus phaenopyrum</i>	Washington Hawthorn	20-25'	Ornamental
<i>Crataegus viridis</i> 'Winter King'	Winter King Hawthorn	15-25'	Ornamental
<i>Eucommia ulmoides</i>	Hardy Rubber Tree	40-60'	Shade
<i>Fraxinus americana</i>	White Ash	45-65'	Shade
<i>Fraxinus pennsylvanica</i>	Green Ash	40-50'	Shade
<i>Ginkgo biloba</i>	Ginkgo	40-60'	Shade
<i>Gleditzia tricanthos inermis</i>	Thornless Honeylocust	40-45'	Shade
<i>Koelreuteria paniculata</i>	Golden Rain Tree	20-35'	Ornamental
<i>Liquidambar styraciflua</i>	American Sweet Gum	40-60'	Shade
<i>Malus hybrids</i>	Flowering Crabapple	15-30'	Ornamental
<i>Metasequois glyptostroboides</i>	Dawn Redwood	50-70'	Shade
<i>Nyssa sylvatica</i>	Black Gum	40-70'	Shade
<i>Platanus x acerfolia</i> 'Bloodgood'	Bloodgood London Planetree	50-70'	Shade
<i>Prunus</i> 'Accolade'	Accolade Flowering Cherry	30-40'	Ornamental
<i>Prunus</i> 'Newport'	Newport Plum	15-20'	Ornamental
<i>Prunus maackii</i>	Amur Chokecherry	25-30'	Ornamental
<i>Prunus sargentii</i> 'Columnaris'	Columnar Sargent Cherry	30-40'	Ornamental
<i>Prunus virginiana</i>	Chokecherry	20-25'	Ornamental
<i>Pyrus calleryana</i>	Ornamental Pear	20-25'	Ornamental
<i>Quercus acutissima</i>	Sawtooth Oak	40-50'	Shade
<i>Quercus coccinea</i>	Scarlet Oak	60-80'	Shade
<i>Quercus imbricaria</i>	Shingle Oak	40-65'	Shade
<i>Quercus macrocarpa</i>	Bur Oak	50-80'	Shade
<i>Quercus palustris</i>	Pin Oak	50-80'	Shade
<i>Quercus phellos</i>	Willow Oak	50-70'	Shade
<i>Quercus robur</i>	English Oak	50-70'	Shade
<i>Quercus rubra</i>	Red Oak	40-60'	Shade
<i>Quercus shumardii</i>	Shumard Oak	50-70'	Shade
<i>Tilia americana</i>	American Linden	40-60'	Shade
<i>Tilia cordata</i>	Little-Leaf Linden	40-50'	Shade
<i>Tilia tomentosa</i>	Silver Linden	40-50'	Shade
<i>Zelkova serrata</i> 'Village Green'	Village Green Zelkova	40-60'	Shade

Table C.2: Trees approved for use within the interior of a site

Botanic Name	Common Name	Height	Tree Category
<i>Acer ginalla</i>	Amur Maple	15-20'	Ornamental
<i>Acer griseum</i>	Paperbark Maple	20-30'	Ornamental
<i>Acer palmatum</i>	Japanese Maple	15-20'	Ornamental
<i>Acer platanoides</i>	Norway Maple	40'-70'	Shade
<i>Amelachier canadensis</i>	Serviceberry	30-35'	Ornamental
<i>Amelachier x grandiflora</i>	Serviceberry	25-30'	Ornamental
<i>Amelchier laevis</i>	Allegheny Serviceberry	25-30'	Ornamental
<i>Betula nigra</i>	River Birch	30-40'	Ornamental
<i>Betula papyrifera</i>	Paper Birch	30-40'	Ornamental
<i>Cercidyphyllum japonicum</i>	Katsura Tree	25-40'	Ornamental
<i>Cornus kousa</i>	Japanese Dogwood	20-25'	Ornamental
<i>Cotinus coggyria</i>	Smoke Tree	15-20'	Ornamental
<i>Corataegus laevigata</i>	English Hawthorn	15-20'	Ornamental
<i>Gymnocladus dioicus</i>	Kentucky Coffee Tree	40-50'	Shade
<i>Liriodendron tulipifera</i>	Tulip Tree	60-80'	Shade
<i>Magnolia acuminata</i>	Cucumbertree Magnolia	50-70'	Shade
<i>Magnolia x loebneri</i>	Magnolia	20-30'	Ornamental
<i>Magnolia soulangiana</i>	Saucer Magnolia	15-20'	Ornamental
<i>Magnolia stellata</i>	Star Magnolia	10-15'	Ornamental
<i>Ostrya virginiana</i>	American Hophornbeam	30-40'	Shade
<i>Phellodendron amurense</i>	Amur Corktree	35-45'	Shade
<i>Picea abies</i>	Norway Spruce	50-60'	Evergreen
<i>Picea glauca densata</i>	Black Hills Spruce	50-60'	Evergreen
<i>Picea pungens</i>	Colorado Spruce	60-75'	Evergreen
<i>Picea pungens 'Glauca'</i>	Colorada Blue Spruce	60-75'	Evergreen
<i>Pinus nigra</i>	Austrian Pine	30-60'	Evergreen
<i>Pinus ponderosa</i>	Ponderosa Pine	40-50'	Evergreen
<i>Pinus strobus</i>	Eastern White Pine	50-100'	Evergreen
<i>Prunus serrulata</i>	Oriental Cherry	25-35'	Ornamental
<i>Quercus alba</i>	White Oak	60-80'	Shade
<i>Quercus bicolor</i>	Swamp White Oak	40-50'	Shade
<i>Salix Species</i>	Weeping Willow	25-50'	Shade
<i>Taxodium distichum</i>	Baldcypress	60-80'	Shade
<i>Tsuga canadensis</i>	Canada Hemlock	60-75'	Evergreen

Note: Ash species should be planted in moderation and should not be planted in monocultures, due to the risks of the emerald ash borer infestation.

Table C.3: Upright shrubs approved for screening, hedges, and other plantings

Botanic Name	Common Name	Height
<i>Aronia melanocarpa</i>	Black Chokeberry	4-6'
<i>Berberis thunbergii</i> Hybrids	Japanese Barberry	3-5'
<i>Buddleia davidii</i>	Butterfly Bush	5-8'
<i>Buxus microphylla</i>	Littleleaf Boxwood	2-3'
<i>Buxus x koreana</i> hybrids	Sheridan Hybrid Boxwood	2-4'
<i>Caryopteris x clandonensis</i>	Blue Mist Spirea	3'
<i>Chaenomeles</i> species	Flowering Quince	2-6'
<i>Clethra alnifolia</i>	Summersweet	3-6'
<i>Cornus alba</i>	Variegated Red Twig Dogwood	6-10'
<i>Cornus alternifolia</i>	Pagoda Dogwood	15-20'
<i>Cornus sericea</i>	Redtwig Dogwood	8-10'
<i>Cotinus coggygria</i>	Smoke Tree	8-10'
<i>Cotoneaster apiculata</i>	Cranberry Cotoneaster	4-8'
<i>Cotoneaster divaricata</i>	Spreading Cotoneaster	5-6'
<i>Euonymus alatus</i>	Burning Bush	7-10'
<i>Euonymus fortunei</i>	Euonymous	4-6'
<i>Forsythia intermedia</i> Hybrids	Hybrid Forsythia	7-10'
<i>Hamamelis virginiana</i>	Common Witch Hazel	10-15'
<i>Hibiscus syriacus</i>	Rose of Sharon	4-12'
<i>Hydrangea arborescens</i> 'Annabelle'	Annabelle Hydrangea	4-15'
<i>Hydrangea macrophylla</i> hybrids	Bigleaf Hydrangea	3-5'
<i>Hydrangea paniculata</i> hybrids	Panicle Hydrangea	6-10'
<i>Hydrangea quercifolia</i>	Oakleaf Hydrangea	5-10'
<i>Ilex crenata</i>	Japanese Holly	3-5'
<i>Ilex glabra</i>	Inkberry	3-6'
<i>Ilex meserveae</i>	Blue Holly	6-8'
<i>Ilex verticillata</i>	Winterberry	6-9'
<i>Itea virginica</i>	Sweetspire	3-5'
<i>Juniperus chinensis</i>	Chinese Juniper	6-15'
<i>Juniperus scopulorum</i>	Rocky Mountain Juniper	6-15'
<i>Ligustrum amurense</i>	Amur Privet	4-8'
<i>Ligustrum 'Vicary'</i>	Golden Vicary Privet	4-12'
<i>Mahonia aquifolium</i>	Oregon Grape Holly	3-6'
<i>Myrica pennsylvanica</i>	Northern Bayberry	8-10'
<i>Philadelphus coronarius</i>	Sweet Mockorange	8-10'
<i>Physocarpus opulifolius</i> <i>intermedius</i>	Dwarf Ninebark	4-5'
<i>Picea abies</i>	Dwarf varieties of Norway Spruce	2-5'
<i>Picea glauca conica</i>	Dwarf Alberta Spruce	6-10'
<i>Pinus mugo</i>	Mugho Pine	3-6'
<i>Potentilla fruticosa</i>	Potentilla	2-3'
<i>Prunus cistena</i>	Cistena Plum	6-8'
<i>Prunus glandulosa</i>	Dwarf Flowering Almond	4-6'
<i>Prunus triloba</i>	Flowering Almond	8-10'
<i>Pyracantha</i>	Scarlet Firethorn	5-15'
<i>Rhamnus frangula</i>	Alder Buckthorn	12-15'
<i>Rhus aromatica</i>	Fragment Sumac	4-6'

Botanic Name	Common Name	Height
<i>Rhus glabra</i>	Smooth Sumac	8-10'
<i>Rhus typhina</i>	Staghorn Sumac	8-12'
<i>Salix caprea</i>	French Pussy Willow	15-20'
<i>Sambucus nigra</i>	European Elderberry	6-12'
<i>Spiraea hybrids</i>	Spirea	2-8'
<i>Syringa chinensis</i>	Chinese Lilac	6-8'
<i>Syringa meyeri</i> 'Palibin'	Dwarf Korean Lilac	5'
<i>Syringa patula</i> 'Miss Kim'	Miss Kim Lilac	4-6'
<i>Syringa vulgaris</i>	Common Lilac	8-12'
<i>Syringa vulgaris</i> Hybrids	Hybrid French Lilac	8-12'
<i>Taxus cuspidata</i>	Upright or Columnar Japanese Yew	10-25'
<i>Taxus x media</i>	Spreading and Upright Yew	2-12'
<i>Taxus</i> 'Hicksi'	Hick's Yew	10-12'
<i>Thuja occidentalis</i> Hybrids	American Arborvitae	4-15'
<i>Viburnum carlesii</i>	Korean spice Viburnum	4-6'
<i>Viburnum dentatum</i>	Arrowwood Viburnum	10-15'
<i>Viburnum lantana</i>	Wayfaring Tree	8-15'
<i>Viburnum lantago</i>	Nannyberry	8-15'
<i>Viburnum opulus</i>	European Cranberry Bush	10-12'
<i>Viburnum plicatum tomentosum</i>	Doublefile Viburnum	8-10'
<i>Viburnum prunifolium</i>	Black Haw Viburnum	10-12'
<i>Viburnum x rhytidophylloides</i>	Leatherleaf Viburnum	6-15'
<i>Viburnum trilobum</i>	American Cranberry Bush	8-12'
<i>Weigela florida</i>	Flowering Weigela	4-5'
<i>Weigela vaniceki</i>	Cardinal Shrub	4-5'

Table C.4: Spreading shrubs approved for low borders and ground covers

Botanic Name	Common Name	Height
Ajuga	Bugleweed	6-8"
Berberis mentorensis	Mentor Barberry	3-4'
Berberis thunbergii Hybrids	Japanese Barberry	2-4'
Buxus x koreana hybrids	Sheridan Hybrid Boxwood	2-4'
Caryopteris x clandonensis	Blue Mist Spirea	3'
Clethera alnifolia 'Hummingbird'	Hummingbird Summersweet	3-5'
Cotoneaster apiculata	Cranberry Cotoneaster	2-3'
Cotoneaster horizontalis	Rockspray Cotoneaster D	1-3'
Daphne burkwoodii	Burkwood Daphne	3-4'
Duetzia gracilis	Slender Duetzia	2-3'
Euonymus fortunei 'Coloratus'	Purpleleaf wintercreeper	6-8"
Forsythia viridissima 'Bronxensis'	Dwarf Forsythia	1-2'
Hedera helix	English Ivy	6-8"
Hypericon patulum	St. John's Wort	2-3'
Ilex glabra 'Shamrock'	Shamrock Compact inkberry	
Juniperus (spreading varieties)	Juniper	1-3'
Mohonia aquifolium 'Compacta'	Dwarf Oregon Grape	2'
Microbiota decussata	Siberian Cypress	1'
Pacchysandra terminalis	Japanese Spurge	6-8"
Picea abies 'Elegans'	Elegans Dwarf Norway Spruce	3'
Picea abies 'Little Gem'	Little /Gem Spruce	3'
Picea abies 'Nidformis'	Birdnest Spruce	2'
Picea abies 'Pumila'	Dwarf Norway Spruce	2-3'
Picea pungens glauca 'Globosa'	Blue Globe Spruce	3-4'
Picea mariana 'Nana'	Blue Newt Spruce	3'
Pinus mugo	Mugho Pine	3-4'
Potentilla fruticosa Hybrids	Bush Cinqufoil	2-3'
Rhus aromatica 'Low Grow'	Low Grow Fragrant Sumac	1-2'
Ribes alpinum	Alpine Currant	3-5'
Spirea x bumalda	Spirea	2-3'
Spirea japonica	Japanese Spirea	2-3'
Spirea nipponica	Nippon Spirea	2-3'
Syringa patula 'Miss Kim'	Dwarf Korean Lilac	3-5'
Taxus cupidata 'Nana'	Dwarf Japanese Yew	2-3'
Taxus media (spreading)	Spreading Yew	2-4'
Thuja occidentalis 'Hetzil Midget'	Hetz Midget Arborvitae	2-3'
Thuja occidentalis 'Rheingold'	Rheingold Arborvitae	3'
Viburnum opulus 'Nana'	European Cranberry Bush	1-2'
Vinca minor	Periwinkle	6"

Table C.5: Vines for Walls and Fences

Botanic Name	Common Name
Aristolochia durior	Dutchmans's Pipe
Campsis radicans	Trumpet Creeper
Clematis	Clematis Hybrids
Hydrangea anomola	Climbing Hydrangeas
Lonicera x brownii	Dropmore Scarlet Honeysuckle
Lonicera x heckrottii	Goldflame Honeysuckle
Parthenocissus quinquefolia	Virginia Creeper
Parthenocissus tricuspidata	Boston Ivy
Wisteria floribunda	Japanese Wisteria

APPENDIX D PROCESS CHARTS

Appendix E
REGULATIONS FOR FLOOD HAZARD AREAS
FOR WHITE COUNTY

Article 1. Statutory Authorization, Findings of Fact, Purpose, and Objectives.

Section A. Statutory Authorization.

The Indiana Legislature has in IC 36-7-4 and IC 14-28-4 granted the power to local government units to control land use within their jurisdictions.

Section B. Findings of Fact.

- (1) The flood hazard areas of White County, City of Monticello, Town of Monon, Town of Chalmers, Town of Reynolds, Town of Wolcott and Town of Brookston, hereinafter referred to as the County, are subject to periodic inundation which results in loss of life and property, health and safety hazards, disruption of commerce and governmental services, extraordinary public expenditures for flood protection and relief, and impairment of the tax base, all of which adversely affect the public health, safety, and general welfare.
- (2) These flood losses are caused by the cumulative effect of obstructions in floodplains causing increases in flood heights and velocities, and by the occupancy in flood hazard areas by uses vulnerable to floods or hazardous to other lands which are inadequately elevated, flood-proofed, or otherwise unprotected from flood damages.

Section C. Statement of Purpose.

It is the purpose of these regulations to promote the public health, safety, and general welfare and to minimize public and private losses due to flood conditions in specific areas by provisions designed to:

- (1) Restrict or prohibit uses which are dangerous to health, safety, and property due to water or erosion hazards, which result in damaging increases in erosion or in flood heights or velocities.
- (2) Require that uses vulnerable to floods, including facilities which serve such uses, be protected against flood damage at the time of initial construction.
- (3) Control the alteration of natural floodplains, stream channels, and natural protective barriers which are involved in the accommodation of flood waters.
- (4) Control filling, grading, dredging, and other development which may increase erosion or flood damage.
- (5) Prevent or regulate the construction of flood barriers which will unnaturally divert floodwaters or which may increase flood hazards to other lands.
- (6) Make federally subsidized flood insurance available for structures and their contents in the County by fulfilling the requirements of the National Flood Insurance Program.

Section D. Objectives.

The objectives of these regulations are:

- (1) To protect human life and health.
- (2) To minimize expenditure of public money for costly flood control projects.
- (3) To minimize the need for rescue and relief efforts associated with flooding and generally undertaken at the expense of the general public.
- (4) To minimize prolonged business interruptions.
- (5) To minimize damage to public facilities and utilities such as water and gas mains, electric, telephone, and sewer lines, streets, and bridges located in floodplains.
- (6) To help maintain a stable tax base by providing for the sound use and development of flood prone areas in such a manner as to minimize flood blight areas.
- (7) To ensure that potential homebuyers are notified that property is in a flood area.

Article 2. Definitions.

Unless specifically defined below, words or phrases used in these regulations shall be interpreted so as to give them the meaning they have in the White County Indiana Zoning and Subdivision Control Ordinances and to give these regulations their most reasonable application.

A zone means portions of the SFHA in which the principal source of flooding is runoff from rainfall, snowmelt, or a combination of both. In A zones, floodwaters may move slowly or rapidly, but waves are usually not a significant threat to buildings. These areas are labeled as Zone A, Zone AE, Zones A1-A30, Zone AO, Zone AH, Zone AR and Zone A99 on a FIRM or FHBM. The definitions are presented below:

Zone A: Areas subject to inundation by the one-percent annual chance flood event. Because detailed hydraulic analyses have not been performed, no base flood elevation or depths are shown. Mandatory flood insurance purchase requirements apply.

Zone AE and A1-A30: Areas subject to inundation by the one-percent annual chance flood event determined by detailed methods. Base flood elevations are shown within these zones. Mandatory flood insurance purchase requirements apply. (Zone AE is on new and revised maps in place of Zones A1-A30.)

Zone AO: Areas subject to inundation by one-percent annual chance shallow flooding (usually sheet flow on sloping terrain) where average depths are between one and three feet. Average flood depths derived from detailed hydraulic analyses are shown within this zone. Mandatory flood insurance purchase requirements apply.

Zone AH: Areas subject to inundation by one-percent annual chance shallow flooding (usually areas of ponding) where average depths are between one and three feet. Average flood depths derived from detailed hydraulic analyses are shown within this zone. Mandatory flood insurance purchase requirements apply.

Zone AR: Areas that result from the decertification of a previously accredited flood protection system that is determined to be in the process of being restored to provide base flood protection. Mandatory flood insurance purchase requirements apply.

Zone A99: Areas subject to inundation by the one-percent annual chance flood event, but which will ultimately be protected upon completion of an under-construction Federal flood protection system. These are areas of special flood hazard where enough progress has been made on the construction of a protection system, such as dikes, dams, and levees, to consider it complete for insurance rating purposes. Zone A99 may only be used when the flood protection system has reached specified statutory progress toward completion. No base flood elevations or depths are shown. Mandatory flood insurance purchase requirements apply.

Accessory structure (appurtenant structure) means a structure that is located on the same parcel of property as the principal structure and the use of which is incidental to the use of the principal structure. Accessory structures should constitute a minimal initial investment, may not be used for human habitation, and be designed to have minimal flood damage potential. Examples of accessory structures are detached garages, carports, storage sheds, pole barns, and hay sheds.

Addition (to an existing structure) means any walled and roofed expansion to the perimeter of a structure in which the addition is connected by a common load-bearing wall other than a firewall. Any walled and roofed addition, which is connected by a firewall or is separated by independent perimeter load-bearing walls, is new construction.

Appeal means a request for a review of the floodplain administrator's interpretation of any provision of these regulations or a request for a variance.

Area of shallow flooding means a designated AO or AH Zone on the community's Flood Insurance Rate Map (FIRM) with base flood depths from one to three feet where a clearly defined channel does not exist, where the path of flooding is unpredictable and indeterminate, and where velocity flow may be evident. Such flooding is characterized by ponding or sheet flow.

Base Flood Elevation (BFE) means the elevation of the one-percent annual chance flood.

Basement means that portion of a structure having its floor sub-grade (below ground level) on all sides.

Building - see "Structure."

Community means a political entity that has the authority to adopt and enforce floodplain ordinances for the area under its jurisdiction.

Community Rating System (CRS) means a program developed by the Federal Insurance Administration to provide incentives for those communities in the Regular Program that have gone beyond the minimum floodplain management requirements to develop extra measures to provide protection from flooding.

Critical facility means a facility for which even a slight chance of flooding might be too great. Critical facilities include, but are not limited to, schools, nursing homes, hospitals, police, fire, and emergency response installations, installations which produce, use or store hazardous materials or hazardous waste.

Development means any man-made change to improved or unimproved real estate including but not limited to:

- (1) construction, reconstruction, or placement of a structure or any addition to a structure;
- (2) installing a manufactured home on a site, preparing a site for a manufactured home or installing a recreational vehicle on a site for more than 180 days;
- (3) installing utilities, erection of walls and fences, construction of roads, or similar projects;

- (4) construction of flood control structures such as levees, dikes, dams, channel improvements, etc.;
- (5) mining, dredging, filling, grading, excavation, or drilling operations;
- (6) construction and/or reconstruction of bridges or culverts;
- (7) storage of materials; or
- (8) any other activity that might change the direction, height, or velocity of flood or surface waters.

"Development" does not include activities such as the maintenance of existing structures and facilities such as painting, re-roofing; resurfacing roads; or gardening, plowing, and similar agricultural practices that do not involve filling, grading, excavation, or the construction of permanent structures.

Elevated structure means a non-basement structure built to have the lowest floor elevated above the ground level by means of fill, solid foundation perimeter walls, filled stem wall foundations (also called chain walls), pilings, or columns (posts and piers).

Elevation Certificate is a certified statement that verifies a structure's elevation information.

Emergency Program means the first phase under which a community participates in the NFIP. It is intended to provide a first layer amount of insurance at subsidized rates on all insurable structures in that community before the effective date of the initial FIRM.

Encroachment means the advance or infringement of uses, fill, excavation, buildings, permanent structures or development into a floodplain, which may impede or alter the flow capacity of a floodplain.

Existing Construction means any structure for which the "start of construction" commenced before the effective date of the community's first floodplain ordinance.

Existing manufactured home park or subdivision means a manufactured home park or subdivision for which the construction of facilities for servicing the lots on which the manufactured homes are to be affixed (including, at a minimum, the installation of utilities, the construction of streets, and either final site grading or the pouring of concrete pads) is completed before the effective date of the community's first floodplain ordinance.

Expansion to an existing manufactured home park or subdivision means the preparation of additional sites by the construction of facilities for servicing the lots on which the manufactured homes are to be affixed (including the installation of utilities, the construction of streets, and either final site grading or the pouring of concrete pads).

FEMA means the Federal Emergency Management Agency.

Five-hundred year flood (500-year flood) means the flood that has a 0.2 percent chance of being equaled or exceeded in any year.

Flood means a general and temporary condition of partial or complete inundation of normally dry land areas from the overflow, the unusual and rapid accumulation, or the runoff of surface waters from any source.

Flood Boundary and Floodway Map (FBFM) means an official map on which the Federal Emergency Management Agency (FEMA) or Federal Insurance Administration (FIA) has delineated the areas of flood hazards and regulatory floodway.

Flood Hazard Boundary Map (FHBM) means an official map of a community, issued by FEMA, where the boundaries of the areas of special flood hazard have been identified as Zone A.

Flood Insurance Rate Map (FIRM) means an official map of a community, on which FEMA has delineated both the areas of special flood hazard and the risk premium zones applicable to the community.

Flood Insurance Study (FIS) is the official hydraulic and hydrologic report provided by FEMA. The report contains flood profiles, as well as the FIRM, FBFM (where applicable), and the water surface elevation of the base flood.

Flood Prone Area means any land area acknowledged by a community as being susceptible to inundation by water from any source. (See "Flood")

Flood Protection Grade (FPG) is the elevation of the regulatory flood plus two feet at any given location in the SFHA (see "Freeboard").

Floodplain means the channel proper and the areas adjoining any wetland, lake, or watercourse which have been or hereafter may be covered by the regulatory flood. The floodplain includes both the floodway and the fringe districts.

Floodplain management means the operation of an overall program of corrective and preventive measures for reducing flood damage and preserving and enhancing, where possible, natural resources in the floodplain, including but not limited to emergency preparedness plans, flood control works, floodplain management regulations, and open space plans.

Floodplain management regulations means these regulations and other zoning ordinances, subdivision regulations, building codes, health regulations, special purpose ordinances, and other applications of police power which control development in flood-prone areas. This term describes federal, state, or local regulations in any combination thereof, which provide standards for preventing and reducing flood loss and damage. Floodplain management regulations are also referred to as floodplain regulations, floodplain ordinance, flood damage prevention ordinance, and floodplain management requirements.

Floodproofing (dry floodproofing) is a method of protecting a structure that ensures that the structure, together with attendant utilities and sanitary facilities, is watertight to the floodproofed design elevation with walls that are substantially impermeable to the passage of water. All structural components of these walls are capable of resisting hydrostatic and hydrodynamic flood forces, including the effects of buoyancy, and anticipated debris impact forces.

Floodproofing certificate is a form used to certify compliance for non-residential structures as an alternative to elevating structures to or above the FPG. This certification must be by a Registered Professional Engineer or Architect.

Floodway is the channel of a river or stream and those portions of the floodplains adjoining the channel which are reasonably required to efficiently carry and discharge the peak flood flow of the regulatory flood of any river or stream.

Freeboard means a factor of safety, usually expressed in feet above the BFE, which is applied for the purposes of floodplain management. It is used to compensate for the many unknown factors that could contribute to flood heights greater than those calculated for the base flood.

Fringe is those portions of the floodplain lying outside the floodway.

Functionally dependent facility means a facility which cannot be used for its intended purpose unless it is located or carried out in close proximity to water, such as a docking or port facility necessary for the

loading and unloading of cargo or passengers, shipbuilding, ship repair, or seafood processing facilities. The term does not include long-term storage, manufacture, sales, or service facilities.

Hardship (as related to variances of these regulations) means the exceptional hardship that would result from a failure to grant the requested variance. The White County Area Board of Commissioners requires that the variance is exceptional, unusual, and peculiar to the property involved. Mere economic or financial hardship alone is NOT exceptional. Inconvenience, aesthetic considerations, physical handicaps, personal preferences, or the disapproval of one's neighbors likewise cannot, as a rule, qualify as an exceptional hardship. All of these problems can be resolved through other means without granting a variance, even if the alternative is more expensive, or requires the property owner to build elsewhere or put the parcel to a different use than originally intended.

Highest adjacent grade means the highest natural elevation of the ground surface, prior to the start of construction, next to the proposed walls of a structure.

Historic structure means any structure individually listed on the National Register of Historic Places or the Indiana State Register of Historic Sites and Structures.

Increased Cost of Compliance (ICC) means the cost to repair a substantially damaged structure that exceeds the minimal repair cost and that is required to bring a substantially damaged structure into compliance with the local flood damage prevention ordinance. Acceptable mitigation measures are elevation, relocation, demolition, or any combination thereof. All renewal and new business flood insurance policies with effective dates on or after June 1, 1997, will include ICC coverage.

Letter of Map Amendment (LOMA) means an amendment to the currently effective FEMA map that establishes that a property is not located in a SFHA. A LOMA is only issued by FEMA.

Letter of Map Revision (LOMR) means an official revision to the currently effective FEMA map. It is issued by FEMA and changes flood zones, delineations, and elevations.

Letter of Map Revision Based on Fill (LOMR-F) means an official revision by letter to an effective NFIP map. A LOMR-F provides FEMA's determination concerning whether a structure or parcel has been elevated on fill above the BFE and excluded from the SFHA.

Lowest adjacent grade means the lowest elevation, after completion of construction, of the ground, sidewalk, patio, deck support, or basement entryway immediately next to the structure.

Lowest floor means the lowest of the following:

- (1) the top of the lowest level of the structure;
- (2) the top of the basement floor;
- (3) the top of the garage floor, if the garage is the lowest level of the structure;
- (4) the top of the first floor of a structure elevated on pilings or pillars;
- (5) the top of the floor level of any enclosure, other than a basement, below an elevated structure where the walls of the enclosure provide any resistance to the flow of flood waters unless:
 - a. the walls are designed to automatically equalize the hydrostatic flood forces on the walls by allowing for the entry and exit of flood waters by providing a minimum of two openings (in addition to doorways and windows) in a minimum of two exterior walls having a total net area of one (1) square inch for every one square foot of enclosed area. The bottom of all such openings shall be no higher than one (1) foot above the exterior grade or the interior grade immediately beneath each opening, whichever is higher; and,

- b. such enclosed space shall be usable solely for the parking of vehicles and building access.

Manufactured home means a structure, transportable in one or more sections, which is built on a permanent chassis and is designed for use with or without a permanent foundation when attached to the required utilities. The term "manufactured home" does not include a "recreational vehicle."

Manufactured home park or subdivision means a parcel (or contiguous parcels) of land divided into two or more manufactured home lots for rent or sale.

Map amendment means a change to an effective NFIP map that results in the exclusion from the SFHA of an individual structure or a legally described parcel of land that has been inadvertently included in the SFHA (i.e., no alterations of topography have occurred since the date of the first NFIP map that showed the structure or parcel to be within the SFHA).

Map panel number is the four-digit number followed by a letter suffix assigned by FEMA on a flood map. The first four digits represent the map panel, and the letter suffix represents the number of times the map panel has been revised. (The letter "A" is not used by FEMA, the letter "B" is the first revision.)

Market value means the building value, excluding the land (as agreed to between a willing buyer and seller), as established by what the local real estate market will bear. Market value can be established by independent certified appraisal, replacement cost depreciated by age of building (actual cash value), or adjusted assessed values.

Mitigation means sustained actions taken to reduce or eliminate long-term risk to people and property from hazards and their effects. The purpose of mitigation is two fold: to protect people and structures, and to minimize the cost of disaster response and recovery.

National Flood Insurance Program (NFIP) is the federal program that makes flood insurance available to owners of property in participating communities nationwide through the cooperative efforts of the Federal Government and the private insurance industry.

National Geodetic Vertical Datum (NGVD) of 1929 as corrected in 1929 is a vertical control used as a reference for establishing varying elevations within the floodplain.

New construction means any structure for which the "start of construction" commenced after the effective date of the community's first floodplain ordinance.

New manufactured home park or subdivision means a manufactured home park or subdivision for which the construction of facilities for servicing the lots on which the manufactured homes are to be affixed (including at a minimum, the installation of utilities, the construction of streets, and either final site grading or the pouring of concrete pads) is completed on or after the effective date of the community's first floodplain ordinance.

North American Vertical Datum of 1988 (NAVD 88) as adopted in 1993 is a vertical control datum used as a reference for establishing varying elevations within the floodplain.

Obstruction includes, but is not limited to, any dam, wall, wharf, embankment, levee, dike, pile, abutment, protection, excavation, canalization, bridge, conduit, culvert, building, wire, fence, rock, gravel, refuse, fill, structure, vegetation, or other material in, along, across or projecting into any watercourse which may alter, impede, retard or change the direction and/or velocity of the flow of water; or due to its location, its propensity to snare or collect debris carried by the flow of water, or its likelihood of being carried downstream.

One-hundred year flood (100-year flood) is the flood that has a one percent (1%) chance of being equaled or exceeded in any given year. Any flood zone that begins with the letter A is subject to the one-percent annual chance flood. See "Regulatory Flood".

One-percent annual chance flood is the flood that has a one percent (1%) chance of being equaled or exceeded in any given year. Any flood zone that begins with the letter A is subject to the one-percent annual chance flood. See "Regulatory Flood".

Participating community is any community that voluntarily elects to participate in the NFIP by adopting and enforcing floodplain management regulations that are consistent with the standards of the NFIP.

Physical Map Revision (PMR) is an official republication of a community's FEMA map to effect changes to base (1-percent annual chance) flood elevations, floodplain boundary delineations, regulatory floodways, and planimetric features. These changes typically occur as a result of structural works or improvements, annexations resulting in additional flood hazard areas, or correction to base flood elevations or SFHAs.

Post-FIRM construction means construction or substantial improvement that started on or after the effective date of the initial FIRM of the community or after December 31, 1974, whichever is later.

Pre-FIRM construction means construction or substantial improvement, which started on or before December 31, 1974, or before the effective date of the initial FIRM of the community, whichever is later.

Probation is a means of formally notifying participating communities of violations and deficiencies in the administration and enforcement of the local floodplain management regulations.

Public safety and nuisance means anything which is injurious to the safety or health of an entire community, neighborhood or any considerable number of persons, or unlawfully obstructs the free passage or use, in the customary manner, of any navigable lake, or river, bay, stream, canal, or basin.

Recreational vehicle means a vehicle which is (1) built on a single chassis; (2) 400 square feet or less when measured at the largest horizontal projections; (3) designed to be self-propelled or permanently towable by a light duty truck; and (4) designed primarily not for use as a permanent dwelling, but as quarters for recreational camping, travel, or seasonal use.

Regular program means the phase of the community's participation in the NFIP where more comprehensive floodplain management requirements are imposed and higher amounts of insurance are available based upon risk zones and elevations determined in a FIS.

Regulatory flood means the flood having a one percent (1%) chance of being equaled or exceeded in any given year, as calculated by a method and procedure that is acceptable to and approved by the Indiana Department of Natural Resources and the Federal Emergency Management Agency. The regulatory flood elevation at any location is as defined in Article 3 (B) of these regulations. The "Regulatory Flood" is also known by the term "Base Flood", "One-Percent Annual Chance Flood", and "100-Year Flood".

Repetitive loss means flood-related damages sustained by a structure on two separate occasions during a 10-year period ending on the date of the event for which the second claim is made, in which the cost of repairing the flood damage, on the average, equaled or exceeded 25% of the market value of the structure at the time of each such flood event.

Section 1316 is that section of the National Flood Insurance Act of 1968, as amended, which states that no new flood insurance coverage shall be provided for any property that the Administrator finds has been declared by a duly constituted state or local zoning authority or other authorized public body to be in violation of state or local laws, regulations, or ordinances that intended to discourage or otherwise restrict land development or occupancy in flood-prone areas.

Special Flood Hazard Area (SFHA) means those lands within the jurisdictions of the County subject to inundation by the regulatory flood. The SFHAs of the County are generally identified as such on the White County, Indiana and Incorporated Areas Flood Insurance Rate Map prepared by the Federal Emergency Management Agency, dated January 8, 2014 as well as any future updates, amendments, or revisions, prepared by the Federal Emergency Management Agency with the most recent date. The SFHAs of those parts of unincorporated White County that are within the extraterritorial jurisdiction of the City of Monticello, Town of Brookston, Town of Chalmers, Town of Reynolds, Town of Monon or the Town of Wolcott or that may be annexed into the City of Monticello, Town of Brookston, Town of Chalmers, Town of Reynolds, Town of Monon or the Town of Wolcott are generally identified as such on the White County, Indiana and Incorporated Areas Flood Insurance Rate Map prepared by the Federal Emergency Management Agency, dated January 8, 2014 prepared by the Federal Emergency Management Agency and dated January 8, 2014 as well as any future updates, amendments, or revisions, prepared by the Federal Emergency Management Agency with the most recent date. (These areas are shown on a FHBM or FIRM as Zone A, AE, A1- A30, AH, AR, A99, or AO).

Start of construction includes substantial improvement, and means the date the building permit was issued, provided the actual start of construction, repair, reconstruction, or improvement was within 180 days of the permit date. The actual start means either the first placement of permanent construction of a structure on a site, such as the pouring of a slab or footings, the installation of piles, the construction of columns, or any work beyond the stage of excavation; or the placement of a manufactured home on a foundation. Permanent construction does not include land preparation, such as clearing, grading and filling; nor does it include the installation of streets and/or walkways; nor does it include excavation for a basement, footings, piers, foundations, or the erection of temporary forms; nor does it include the installation on the property of accessory buildings, such as garages or sheds not occupied as dwelling units or not part of the main structure. For a substantial improvement, the actual start of construction means the first alteration of any wall, ceiling, floor, or other structural part of a building, whether or not that alteration affects the external dimensions of the building.

Structure means a structure that is principally above ground and is enclosed by walls and a roof. The term includes a gas or liquid storage tank, a manufactured home, or a prefabricated building. The term also includes recreational vehicles to be installed on a site for more than 180 days.

Substantial damage means damage of any origin sustained by a structure whereby the cost of restoring the structure to its before damaged condition would equal or exceed 50 percent of the market value of the structure before the damage occurred.

Substantial improvement means any reconstruction, rehabilitation, addition, or other improvement of a structure, the cost of which equals or exceeds 50 percent of the market value of the structure before the "start of construction" of the improvement. This term includes structures that have incurred "repetitive loss" or "substantial damage" regardless of the actual repair work performed. The term does not include improvements of structures to correct existing violations of state or local health, sanitary, or safety code requirements or any alteration of a "historic structure", provided that the alteration will not preclude the structures continued designation as a "historic structure".

Suspension means the removal of a participating community from the NFIP because the community has not enacted and/or enforced the proper floodplain management regulations required for participation in the NFIP.

Variance is a grant of relief from the requirements of these regulations, which permits construction in a manner otherwise prohibited by these regulations where specific enforcement would result in unnecessary hardship.

Violation means the failure of a structure or other development to be fully compliant with these regulations. A structure or other development without the elevation, other certification, or other

evidence of compliance required in these regulations is presumed to be in violation until such time as that documentation is provided.

Watercourse means a lake, river, creek, stream, wash, channel or other topographic feature on or over which waters flow at least periodically. Watercourse includes specifically designated areas in which substantial flood damage may occur.

Water surface elevation means the height, in relation to the North American Vertical Datum of 1988 (NAVD 88) or National Geodetic Vertical Datum of 1929 (NGVD) (other datum where specified) of floods of various magnitudes and frequencies in the floodplains of riverine areas.

X zone means the area where the flood hazard is less than that in the SFHA. Shaded X zones shown on recent FIRMs (B zones on older FIRMs) designate areas subject to inundation by the flood with a 0.2 percent chance of being equaled or exceeded (the 500-year flood). Unshaded X zones (C zones on older FIRMs) designate areas where the annual exceedance probability of flooding is less than 0.2 percent.

Zone means a geographical area shown on a FHBM or FIRM that reflects the severity or type of flooding in the area.

Zone A (see definition for A zone)

Zone B, C, and X means areas identified in the community as areas of moderate or minimal hazard from the principal source of flood in the area. However, buildings in these zones could be flooded by severe, concentrated rainfall coupled with inadequate local drainage systems. Flood insurance is available in participating communities but is not required by regulation in these zones. (Zone X is used on new and revised maps in place of Zones B and C.)

Article 3. General Provisions.

Section A. Lands to Which These Regulations Apply.

These regulations shall apply to all SFHAs and known flood prone areas within the jurisdiction of the County.

Section B. Basis for Establishing Regulatory Flood Data.

These regulations' protection standard is the regulatory flood. The best available regulatory flood data is listed below. Whenever a party disagrees with the best available data, the party submitting the detailed engineering study needs to replace existing data with better data and submit it to the Indiana Department of Natural Resources for review and approval.

- (1) The regulatory flood elevation, floodway, and fringe limits for the studied SFHAs within the jurisdiction of the County shall be as delineated on the one-percent annual chance flood profiles in the Flood Insurance Study of White County, Indiana and Incorporated Areas dated January 8, 2014 and the corresponding Flood Insurance Rate Map prepared by the Federal Emergency Management Agency and dated January 8, 2014 as well as any future updates, amendments, or revisions, prepared by the Federal Emergency Management Agency with the most recent date.
- (2) The regulatory flood elevation, floodway, and fringe limits for each of the SFHAs within the jurisdiction of the County, delineated as an "A Zone" on the White County, Indiana and Incorporated Areas Flood Insurance Rate Map prepared by the Federal Emergency

Management Agency and dated January 8, 2014 as well as any future updates, amendments, or revisions, prepared by the Federal Emergency Management Agency with the most recent date shall be according to the best data available as provided by the Indiana Department of Natural Resources; provided the upstream drainage area from the subject site is greater than one square mile.

- (3) In the absence of a published FEMA map, or absence of identification on a FEMA map, the regulatory flood elevation, floodway, and fringe limits of any watercourse in the community's known flood prone areas shall be according to the best data available as provided by the Indiana Department of Natural Resources; provided the upstream drainage area from the subject site is greater than one square mile.

Section C. Establishment of Floodplain Development Permit.

A Floodplain Development Permit shall be required in conformance with the provisions of these regulations prior to the commencement of any development activities in areas of special flood hazard.

Section D. Compliance.

No structure shall hereafter be located, extended, converted or structurally altered within the SFHA without full compliance with the terms of these regulations and other applicable regulations. No land or stream within the SFHA shall hereafter be altered without full compliance with the terms of these regulations and other applicable regulations.

Section E. Abrogation and Greater Restrictions.

These regulations are not intended to repeal, abrogate, or impair any existing easements, covenants, or deed restrictions. However, where these regulations and another conflict or overlap, whichever imposes the more stringent restrictions shall prevail.

Section F. Discrepancy between Mapped Floodplain and Actual Ground Elevations.

- (1) In cases where there is a discrepancy between the mapped floodplain (SFHA) on the FIRM and the actual ground elevations, the elevation provided on the profiles shall govern.
- (2) If the elevation of the site in question is below the base flood elevation, that site shall be included in the SFHA and regulated accordingly.
- (3) If the elevation (natural grade) of the site in question is above the base flood elevation, that site shall be considered outside the SFHA and the floodplain regulations will not be applied. The property owner should be advised to apply for a LOMA.

Section G. Interpretation.

In the interpretation and application of these regulations all provisions shall be:

- (1) Considered as minimum requirements.
- (2) Liberally construed in favor of the governing body.
- (3) Deemed neither to limit nor repeal any other powers granted under state statutes.

Section H. Warning and Disclaimer of Liability.

The degree of flood protection required by these regulations is considered reasonable for regulatory purposes and is based on available information derived from engineering and scientific methods of study. Larger floods can and will occur on rare occasions. Therefore, these regulations do not create any liability on the part of the County, the Indiana Department of Natural Resources, or the State of Indiana, for any flood damage that results from reliance on these regulations or any administrative decision made lawfully thereunder.

Section I. Penalties for Violation.

Failure to obtain a Floodplain Development Permit in the SFHA or failure to comply with the requirements of a Floodplain Development Permit or conditions of a variance shall be deemed to be a violation of these regulations. All violations shall be considered a common nuisance and be treated as such in accordance with the provisions of the Zoning Code for White County. All violations shall be punishable by a fine not exceeding three hundred dollars (\$300.00).

- (1) A separate offense shall be deemed to occur for each day the violation continues to exist.
- (2) The Floodplain Administrator shall inform the owner that any such violation is considered a willful act to increase flood damages and therefore may cause coverage by a Standard Flood Insurance Policy to be suspended.

- (3) Nothing herein shall prevent the County from taking such other lawful action to prevent or remedy any violations. All costs connected therewith shall accrue to the person or persons responsible.

Section J. Increased Cost of Compliance (ICC).

In order for buildings to qualify for a claim payment under ICC coverage as a “repetitive loss structure”, the National Reform Act of 1994 requires that the building be covered by a contract for flood insurance and incur flood-related damages on two occasions during a 10-year period ending on the date of the event for which the second claim is made, in which the cost of repairing the flood damage, on the average, equaled or exceeded 25 percent of the market value of the building at the time of each such flood event.

Article 4. Administration.

Section A. Designation of Administrator.

The White County Area Plan Commission hereby appoints the Building Commissioner to administer and implement the provisions of these regulations and is herein referred to as the Floodplain Administrator.

Section B. Permit Procedures.

Application for a Floodplain Development Permit shall be made to the Floodplain Administrator on forms furnished by him or her prior to any development activities, and may include, but not be limited to, the following: plans in duplicate drawn to scale showing the nature, location, dimensions, and elevations of the area in question; existing or proposed structures, earthen fill, storage of materials or equipment, drainage facilities, and the location of the foregoing. Specifically the following information is required:

- (1) Application stage.
 - a). A description of the proposed development.
 - b). Location of the proposed development sufficient to accurately locate property and structure in relation to existing roads and streams.
 - c). A legal description of the property site.
 - d). A site development plan showing existing and proposed development locations and existing and proposed land grades.
 - e). Elevation of the top of the lowest floor (including basement) of all proposed buildings. Elevation should be in NAVD 88 or NGVD.
 - f). Elevation (in NAVD 88 or NGVD) to which any non-residential structure will be floodproofed.
 - g). Description of the extent to which any watercourse will be altered or relocated as a result of proposed development.

- (2) Construction stage.

Upon placement of the lowest floor; or floodproofing, it shall be the duty of the permit holder to submit to the Floodplain Administrator a certification of the NAVD 88 or NGVD elevation of the lowest floor or floodproofed elevation, as built. Said certification shall be prepared by or under

the direct supervision of a registered land surveyor or professional engineer and certified by the same. When floodproofing is utilized for a particular structure said certification shall be prepared by or under the direct supervision of a professional engineer or architect and certified by same. Any work undertaken prior to submission of the certification shall be at the permit holders' risk. (The Floodplain Administrator shall review the lowest floor and floodproofing elevation survey data submitted.) The permit holder shall correct deficiencies detected by such review before any further work is allowed to proceed. Failure to submit the survey or failure to make said corrections required hereby shall be cause to issue a stop-work order for the project.

Section C. Duties and Responsibilities of the Floodplain Administrator.

The Floodplain Administrator and/or designated staff is hereby authorized and directed to enforce the provisions of these regulations. The administrator is further authorized to render interpretations of these regulations, which are consistent with its spirit and purpose.

Duties and Responsibilities of the Floodplain Administrator shall include, but not be limited to:

- (1) Review all floodplain development permits to assure that the permit requirements of these regulations have been satisfied.
- (2) Inspect and inventory damaged structures in the SFHA and complete substantial damage determinations.
- (3) Ensure that construction authorization has been granted by the Indiana Department of Natural Resources for all development projects subject to Article 5, Section E and G (1) of these regulations, and maintain a record of such authorization (either copy of actual permit or floodplain analysis/regulatory assessment).
- (4) Ensure that all necessary federal or state permits have been received prior to issuance of the local floodplain development permit. Copies of such permits are to be maintained on file with the floodplain development permit.
- (5) Notify adjacent communities and the State Floodplain Coordinator prior to any alteration or relocation of a watercourse, and submit copies of such notifications to FEMA.
- (6) Maintain for public inspection and furnish upon request local permit documents, damaged structure inventories, substantial damage determinations, regulatory flood data, SFHA maps, Letters of Map Amendment (LOMA), Letters of Map Revision (LOMR), copies of DNR permits and floodplain analysis and regulatory assessments (letters of recommendation), federal permit documents, and "as-built" elevation and floodproofing data for all buildings constructed subject to these regulations.
- (7) Utilize and enforce all Letters of Map Revision (LOMR) or Physical Map Revisions (PMR) issued by FEMA for the currently effective SFHA maps of the community.
- (8) Assure that maintenance is provided within the altered or relocated portion of said watercourse so that the flood-carrying capacity is not diminished.
- (9) Verify and record the actual elevation of the lowest floor (including basement) of all new or substantially improved structures, in accordance with Article 4 Section B.
- (10) Verify and record the actual elevation to which any new or substantially improved structures have been floodproofed in accordance with Article 4, Section B.

- (11) Review certified plans and specifications for compliance.
- (12) Stop Work Orders
 - a). Upon notice from the floodplain administrator, work on any building, structure or premises that is being done contrary to the provisions of these regulations shall immediately cease.
 - b). Such notice shall be in writing and shall be given to the owner of the property, or to his agent, or to the person doing the work, and shall state the conditions under which work may be resumed.
- (13) Revocation of Permits
 - a). The floodplain administrator may revoke a permit or approval, issued under the provisions of the ordinance, in cases where there has been any false statement or misrepresentation as to the material fact in the application or plans on which the permit or approval was based.
 - b). The floodplain administrator may revoke a permit upon determination by the floodplain administrator that the construction, erection, alteration, repair, moving, demolition, installation, or replacement of the structure for which the permit was issued is in violation of, or not in conformity with, the provisions of these regulations.
- (14) Inspect sites for compliance. For all new and/or substantially improved buildings constructed in the SFHA, inspect before, during and after construction. Authorized County officials shall have the right to enter and inspect properties located in the SFHA.

Article 5. Provisions for Flood Hazard Reduction.

Section A. General Standards.

In all SFHAs and known flood prone areas the following provisions are required:

- (1) New construction and substantial improvements shall be anchored to prevent flotation, collapse or lateral movement of the structure.
- (2) Manufactured homes shall be anchored to prevent flotation, collapse, or lateral movement. Methods of anchoring may include, but are not limited to, use of over-the-top or frame ties to ground anchors. This standard shall be in addition to and consistent with applicable state requirements for resisting wind forces.
- (3) New construction and substantial improvements shall be constructed with materials and utility equipment resistant to flood damage below the FPG.
- (4) New construction and substantial improvements shall be constructed by methods and practices that minimize flood damage.
- (5) Electrical, heating, ventilation, plumbing, air conditioning equipment, utility meters, and other service facilities shall be located at/above the FPG or designed so as to prevent water from entering or accumulating within the components below the FPG. Water and sewer pipes, electrical and telephone lines, submersible pumps, and other waterproofed service facilities may be located below the FPG.

- (6) New and replacement water supply systems shall be designed to minimize or eliminate infiltration of flood waters into the system.
- (7) New and replacement sanitary sewage systems shall be designed to minimize or eliminate infiltration of flood waters into the system.
- (8) On-site waste disposal systems shall be located and constructed to avoid impairment to them or contamination from them during flooding.
- (9) Any alteration, repair, reconstruction or improvements to a structure that is in compliance with the provisions of these regulations shall meet the requirements of "new construction" as contained in these regulations.
- (10) Any alteration, repair, reconstruction or improvement to a structure that is not in compliance with the provisions of these regulations, shall be undertaken only if said non-conformity is not further extended, or replaced.
- (11) Whenever any portion of the SFHA is authorized for use, the volume of space which will be occupied by the authorized fill or structure below the BFE shall be compensated for and balanced by an equivalent volume of excavation taken below the BFE. The excavation volume shall be at least equal to the volume of storage lost (replacement ratio of 1 to 1) due to the fill or structure.
 - a). The excavation shall take place in the floodplain and in the same property in which the authorized fill or structure is located.
 - b). Under certain circumstances, the excavation may be allowed to take place outside of but adjacent to the floodplain provided that the excavated volume will be below the regulatory flood elevation, will be in the same property in which the authorized fill or structure is located, will be accessible to the regulatory flood water, will not be subject to ponding when not inundated by flood water, and that it shall not be refilled.
 - c). The excavation shall provide for true storage of floodwater but shall not be subject to ponding when not inundated by flood water.
 - d). The fill or structure shall not obstruct a drainage way leading to the floodplain.
 - e). The grading around the excavation shall be such that the excavated area is accessible to the regulatory flood water.
 - f). The fill or structure shall be of a material deemed stable enough to remain firm and in place during periods of flooding and shall include provisions to protect adjacent property owners against any increased runoff or drainage resulting from its placement.
 - g). Plans depicting the areas to be excavated and filled shall be submitted prior to the actual start of construction or any site work; once site work is complete, but before the actual start of construction, the applicant shall provide to the Floodplain Administrator a certified survey of the excavation and fill sites demonstrating the fill and excavation comply with this article.

Section B. Specific Standards.

In all SFHAs, the following provisions are required:

- (1) In addition to the requirements of Article 5, Section A, all structures to be located in the SFHA shall be protected from flood damage below the FPG. This building protection requirement applies to the following situations:
 - a). Construction or placement of any new structure having a floor area greater than 400 square feet.
 - b). Addition or improvement made to any existing structure:
 - (i) where the cost of the addition or improvement equals or exceeds 50% of the value of the existing structure (excluding the value of the land).
 - (ii) with a previous addition or improvement constructed since the community's first floodplain ordinance.
 - c). Reconstruction or repairs made to a damaged structure where the costs of restoring the structure to its before damaged condition equals or exceeds 50% of the market value of the structure (excluding the value of the land) before damage occurred.
 - d). Installing a travel trailer or recreational vehicle on a site for more than 180 days.
 - e). Installing a manufactured home on a new site or a new manufactured home on an existing site. These regulations do not apply to returning the existing manufactured home to the same site it lawfully occupied before it was removed to avoid flood damage.
 - f). Reconstruction or repairs made to a repetitive loss structure.
- (2) **Residential Construction.** New construction or substantial improvement of any residential structure (or manufactured home) shall have the lowest floor, including basement, at or above the FPG (two feet above the base flood elevation). Should solid foundation perimeter walls be used to elevate a structure, openings sufficient to facilitate the unimpeded movements of floodwaters shall be provided in accordance with the standards of Article 5, Section B (4).
- (3) **Non-Residential Construction.** New construction or substantial improvement of any commercial, industrial, or non-residential structure (or manufactured home) shall either have the lowest floor, including basement, elevated to or above the FPG (two feet above the base flood elevation) or be floodproofed to or above the FPG. Should solid foundation perimeter walls be used to elevate a structure, openings sufficient to facilitate the unimpeded movements of floodwaters shall be provided in accordance with the standards of Article 5, Section B (4). Structures located in all "A Zones" may be floodproofed in lieu of being elevated if done in accordance with the following:
 - a). A Registered Professional Engineer or Architect shall certify that the structure has been designed so that below the FPG, the structure and attendant utility facilities are watertight and capable of resisting the effects of the regulatory flood. The structure design shall take into account flood velocities, duration, rate of rise, hydrostatic pressures, and impacts from debris or ice. Such certification shall be provided to the official as set forth in Article 4, Section C (10).
 - b). Floodproofing measures shall be operable without human intervention and without an outside source of electricity.
- (4) **Elevated Structures.** New construction or substantial improvements of elevated structures shall have the lowest floor at or above the FPG.

Elevated structures with fully enclosed areas formed by foundation and other exterior walls below the flood protection grade shall be designed to preclude finished living space and designed to allow for the entry and exit of floodwaters to automatically equalize hydrostatic flood forces on exterior walls. Designs must meet the following minimum criteria:

- a). Provide a minimum of two openings located in a minimum of two exterior walls (having a total net area of not less than one square inch for every one square foot of enclosed area).
 - b). The bottom of all openings shall be no more than one foot above the exterior grade or the interior grade immediately beneath each opening, whichever is higher.
 - c). Openings may be equipped with screens, louvers, valves or other coverings or devices provided they permit the automatic flow of floodwaters in both directions.
 - e). Access to the enclosed area shall be the minimum necessary to allow for parking for vehicles (garage door) or limited storage of maintenance equipment used in connection with the premises (standard exterior door) or entry to the living area (stairway or elevator).
 - f). The interior portion of such enclosed area shall not be partitioned or finished into separate rooms.
 - g). The interior grade of such enclosed area shall be at an elevation at or higher than the exterior grade.
- (5) **Structures Constructed on Fill.** A residential or nonresidential structure may be constructed on a permanent land fill in accordance with the following:
- a). The fill shall be placed in layers no greater than 1 foot deep before compacting to 95% of the maximum density obtainable with either the Standard or Modified Proctor Test method.
 - b). The fill should extend at least ten feet beyond the foundation of the structure before sloping below the FPG.
 - c). The fill shall be protected against erosion and scour during flooding by vegetative cover, riprap, or bulkheading. If vegetative cover is used, the slopes shall be no steeper than 3 horizontal to 1 vertical.
 - d). The fill shall not adversely affect the flow of surface drainage from or onto neighboring properties.
 - e). The top of the lowest floor including basements shall be at or above the FPG.
- (6) **Standards for Manufactured Homes and Recreational Vehicles.** Manufactured homes and recreational vehicles to be installed or substantially improved on a site for more than 180 days must meet one of the following requirements:
- a). The manufactured home shall be elevated on a permanent foundation such that the lowest floor shall be at or above the FPG and securely anchored to an adequately anchored foundation system to resist flotation, collapse, and lateral movement. This requirement applies to all manufactured homes to be placed on a site;
 - (i) outside a manufactured home park or subdivision;

- (ii) in a new manufactured home park or subdivision;
 - (iii) in an expansion to an existing manufactured home park or subdivision; or
 - (iv) in an existing manufactured home park or subdivision on which a manufactured home has incurred "substantial damage" as a result of a flood.
- b). The manufactured home shall be elevated so that the lowest floor of the manufactured home chassis is supported by reinforced piers or other foundation elevations that are no less than 36 inches in height above grade and be securely anchored to an adequately anchored foundation system to resist flotation, collapse, and lateral movement. This requirement applies to all manufactured homes to be placed on a site in an existing manufactured home park or subdivision that has not been substantially damaged by a flood.
- c). Manufactured homes with fully enclosed areas formed by foundation and other exterior walls below the flood protection grade shall be designed to preclude finished living space and designed to allow for the entry and exit of floodwaters to automatically equalize hydrostatic flood forces on exterior walls as required for elevated structures in Article 5, Section B. 4.
- d). Flexible skirting and rigid skirting not attached to the frame or foundation of a manufactured home are not required to have openings.
- e). Recreational vehicles placed on a site shall either:
- (i) be on site for less than 180 days; and,
 - (ii) be fully licensed and ready for highway use (defined as being on its wheels or jacking system, is attached to the site only by quick disconnect type utilities and security devices, and has no permanently attached additions); or
 - (iii) meet the requirements for "manufactured homes" as stated earlier in this section.

Section C. Standards for Subdivision Proposals.

- (1) All subdivision proposals shall be consistent with the need to minimize flood damage.
- (2) All subdivision proposals shall have public utilities and facilities such as sewer, gas, electrical, and water systems located and constructed to minimize flood damage.
- (3) All subdivision proposals shall have adequate drainage provided to reduce exposure to flood hazards.
- (4) Base flood elevation data shall be provided for subdivision proposals and other proposed development (including manufactured home parks and subdivisions), which is greater than the lesser of fifty lots or five acres.

Section D. Critical Facility.

Construction of new critical facilities shall be, to the extent possible, located outside the limits of the SFHA. Construction of new critical facilities shall be permissible within the SFHA if no feasible alternative site is available. Critical facilities constructed within the SFHA shall have the lowest floor elevated to or above the FPG at the site. Floodproofing and sealing measures must be taken to ensure that toxic

substances will not be displaced by or released into floodwaters. Access routes elevated to or above the FPG shall be provided to all critical facilities to the extent possible.

Section E. Standards for Identified Floodways.

Located within SFHAs, established in Article 3, Section B, are areas designated as floodways. The floodway is an extremely hazardous area due to the velocity of floodwaters, which carry debris, potential projectiles, and has erosion potential. If the site is in an identified floodway, the Floodplain Administrator shall require the applicant to forward the application, along with all pertinent plans and specifications, to the Indiana Department of Natural Resources and apply for a permit for construction in a floodway. Under the provisions of IC 14-28-1 a permit for construction in a floodway from the Indiana Department of Natural Resources is required prior to the issuance of a local building permit for any excavation, deposit, construction, or obstruction activity located in the floodway. This includes land preparation activities such as filling, grading, clearing and paving etc. undertaken before the actual start of construction of the structure. However, it does exclude non-substantial additions/improvements to existing (lawful) residences in a non-boundary river floodway. (IC 14-28-1-26 allows construction of non-substantial additions/ improvements to residences in a non-boundary river floodway without obtaining a permit for construction in the floodway from the Indiana Department of Natural Resources. Please note that if fill is needed to elevate an addition above the existing grade, prior approval (construction in a floodway permit) for the fill is required from the Indiana Department of Natural Resources.)

No action shall be taken by the Floodplain Administrator until a permit (when applicable) has been issued by the Indiana Department of Natural Resources granting approval for construction in the floodway. Once a permit for construction in a floodway has been issued by the Indiana Department of Natural Resources, the Floodplain Administrator may issue the local Floodplain Development Permit, provided the provisions contained in Article 5 of these regulations have been met. The Floodplain Development Permit cannot be less restrictive than the permit for construction in a floodway issued by the Indiana Department of Natural Resources. However, a community's more restrictive regulations (if any) shall take precedence.

No development shall be allowed which acting alone or in combination with existing or future development, will increase the regulatory flood more than 0.14 of one foot.

For all projects involving channel modifications or fill (including levees) the **County** shall submit the data and request that the Federal Emergency Management Agency revise the regulatory flood data.

Section F. Standards for Identified Fringe.

If the site is located in an identified fringe, then the Floodplain Administrator may issue the local Floodplain Development Permit provided the provisions contained in Article 5 of these regulations have been met. The key provision is that the top of the lowest floor of any new or substantially improved structure shall be at or above the FPG.

Section G. Standards for SFHAs Without Established Base Flood Elevation and/or Floodways/Fringes.

- (1) Drainage area upstream of the site is greater than one square mile:

If the site is in an identified floodplain where the limits of the floodway and fringe have not yet been determined, and the drainage area upstream of the site is greater than one square mile, the Floodplain Administrator shall require the applicant to forward the application, along with all pertinent plans and specifications, to the Indiana Department of Natural Resources for review and comment.

No action shall be taken by the Floodplain Administrator until either a permit for construction in a floodway or a floodplain analysis/regulatory assessment citing the one-percent annual chance flood elevation and the recommended Flood Protection Grade has been received from the Indiana Department of Natural Resources.

Once the Floodplain Administrator has received the proper permit for construction in a floodway or floodplain analysis/regulatory assessment approving the proposed development, a Floodplain Development Permit may be issued provided the conditions of the Floodplain Development Permit are not less restrictive than the conditions received from the Indiana Department of Natural Resources and the provisions contained in Article 5 of these regulations have been met.

- (2) Drainage area upstream of the site is less than one square mile:

If the site is in an identified floodplain where the limits of the floodway and fringe have not yet been determined and the drainage area upstream of the site is less than one square mile, the Floodplain Administrator shall require the applicant to provide an engineering analysis showing the limits of the floodplain and one-percent annual chance flood elevation for the site.

Upon receipt, the Floodplain Administrator may issue the local Floodplain Development Permit, provided the provisions contained in Article 5 of these regulations have been met.

- (3) The total cumulative effect of the proposed development, when combined with all other existing and anticipated development, will not increase the regulatory flood more than 0.14 of one foot and will not increase flood damages or potential flood damages.

Section H. Standards for Flood Prone Areas.

All development in known flood prone areas not identified on FEMA maps, or where no FEMA published map is available, shall meet applicable standards as required per Article 5.

Article 6. Variance Procedures.

Section A. Designation of Variance and Appeals Board.

The White County Board of Zoning Appeals shall hear and decide appeals and requests for variances from requirements of these regulations.

Section B. Duties of Variance and Appeals Board.

The board shall hear and decide appeals when it is alleged an error in any requirement, decision, or determination is made by the Floodplain Administrator in the enforcement or administration of these regulations. Any person aggrieved by the decision of the board may appeal such decision to the Judicial review as provided for in Chapter 13 of the White County Indiana Zoning Control Ordinance.

Section C. Variance Procedures.

In passing upon such applications, the Board of Zoning Appeals shall consider all technical evaluations, all relevant factors, all standards specified in other sections of these regulations, and;

- (1) The danger of life and property due to flooding or erosion damage.
- (2) The susceptibility of the proposed facility and its contents to flood damage and the effect of such damage on the individual owner.

- (3) The importance of the services provided by the proposed facility to the community.
- (4) The necessity to the facility of a waterfront location, where applicable.
- (5) The availability of alternative locations for the proposed use which are not subject to flooding or erosion damage.
- (6) The compatibility of the proposed use with existing and anticipated development,
- (7) The relationship of the proposed use to the comprehensive plan and floodplain management program for that area.
- (8) The safety of access to the property in times of flood for ordinary and emergency vehicles.
- (9) The expected height, velocity, duration, rate of rise, and sediment of transport of the floodwaters at the site.
- (10) The costs of providing governmental services during and after flood conditions, including maintenance and repair of public utilities and facilities such as sewer, gas, electrical, and water systems, and streets and bridges.

Section D. Conditions for Variances.

- (1) Variances shall only be issued when there is:
 - a). A showing of good and sufficient cause.
 - b). A determination that failure to grant the variance would result in exceptional hardship.
 - c). A determination that the granting of a variance will not result in increased flood heights, additional threats to public safety, extraordinary public expense, create nuisances, cause fraud or victimization of the public, or conflict with existing laws or ordinances.
- (2) No variance for a residential use within a floodway subject to Article 5, Section E or Section G (1) of these regulations may be granted.
- (3) Any variance granted in a floodway subject to Article 5, Section E or Section G (1) of these regulations will require a permit from the Indiana Department of Natural Resources.
- (4) Variances to the Provisions for Flood Hazard Reduction of Article 5, Section B, may be granted only when a new structure is to be located on a lot of one-half acre or less in size, contiguous to and surrounded by lots with existing structures constructed below the flood protection grade.
- (5) Variances shall only be issued upon a determination that the variance is the minimum necessary, considering the flood hazard, to afford relief.
- (6) Variances may be granted for the reconstruction or restoration of any structure individually listed on the National Register of Historic Places or the Indiana State Register of Historic Sites and Structures.
- (7) Any applicant to whom a variance is granted shall be given written notice specifying the difference between the base flood elevation and the elevation to which the lowest floor is to be built and stating that the cost of the flood insurance will be commensurate with the increased risk resulting from the reduced lowest floor elevation (See Article 6, Section E).
- (8) The Area Plan Commission Staff shall maintain the records of variances and the Floodplain Administrator shall report any variances to the Federal Emergency Management Agency or the Indiana Department of Natural Resources upon request (See Article 6, Section E).

Section E. Variance Notification.

Any applicant to whom a variance is granted shall be given written notice over the signature of a community official that:

- (1) The issuance of a variance to construct a structure below the base flood elevation will result in increased premium rates for flood insurance up to amounts as high as \$25 for \$100 of insurance coverage; and;
- (2) Such construction below the base flood level increases risks to life and property.

The Area Plan Commission Staff will maintain a record of all variance actions, including justification for their issuance. The Floodplain Administrator will report such variances issued in the community's biennial report submission to the Federal Emergency Management Agency.

Section F. Historic Structure.

Variations may be issued for the repair or rehabilitation of “historic structures” upon a determination that the proposed repair or rehabilitation will not preclude the structure’s continued designation as an “historic structure” and the variance is the minimum to preserve the historic character and design of the structure.

Section G. Special Conditions.

Upon the consideration of the factors listed in Article 6, and the purposes of these regulations, the **White** County Board of Zoning Appeals may attach such conditions to the granting of variances as it deems necessary to further the purposes of these regulations.

Article 7. Severability.

If any section, clause, sentence, or phrase of these Regulations is held to be invalid or unconstitutional by any court of competent jurisdiction, then said holding shall in no way effect the validity of the remaining portions of these Regulations.

Article 8. Effective Date.

These regulations shall take effect upon its passage by the White County Commissioners.

Passed and enacted by the White County Commissioners, Indiana on the
[Click here and type day of month] day of**[Click here and type month]**, 2013.

[Click here and type name of governing body]
[Click here and type name of Community], Indiana

[Click here and type name of individual approving]

[Click here and type name of individual approving]

[Click here and type name of individual approving]

Attest: _____
[Click here and type name of individual attesting]

TABLE OF CONTENTS

Updated 08/21/2023

CHAPTER 1: GENERAL PROVISIONS

1.0	Title	1.1
1.1	Purpose and Intent	1.1
	1.1.1 Purpose.....	1.1
	1.1.2 Intent	1.1
1.2	Authority.....	1.2
1.3	Jurisdiction	1.2
1.4	Uniformity.....	1.2
1.5	Interpretation.....	1.2
	1.5.1 Minimum requirements	1.2
	1.5.2 Conflicting requirements	1.2
	1.5.3 Severability.....	1.3
	1.5.4 Saving Provision.....	1.3
	1.5.5 Exclusion.....	1.3
1.6	Amendments	1.3
1.7	Adoption	1.4
1.8	Effective Date	1.4
1.9	Repeal of Pre-Existing Zoning Ordinances	1.4

CHAPTER 2: DISTRICT BOUNDARIES AND USE CLASSIFICATIONS

2.0	Official Zoning Map	2.1
	2.0.1 Identification and location	2.1
	2.0.2 Final Authority	2.1
	2.0.3 Copies	2.1
	2.0.4 Amendment or replacement	2.1
2.1	Interpretation of District Boundaries.....	2.2
	2.1.1 Interpretation standards.....	2.2
	2.1.2 Executive Director Interpretation	2.2
	2.1.3 Plan Commission interpretation provision.....	2.2
	2.1.4 Effect of vacation on zoning district boundaries.....	2.3
2.2	General Standards and Regulations	2.3
	2.2.1 Uses.....	2.3
	2.2.2 Bulk use standards.....	2.3
	2.2.3 Parking standards	2.3
	2.2.4 Landscaping standards	2.3
	2.2.5 Sign standards	2.3

2.3	Establishment of Districts	2.3
2.4	District Classifications - General	2.4
2.4.1	Agricultural districts	2.4
2.4.2	Residential districts	2.4
2.4.3	Non-residential districts	2.5
2.4.4	Overlay districts.....	2.5
2.5	Standards and Regulations by District	2.5
2.5.1	A-1 General Agricultural District	2.5
2.5.2	A-2 Agricultural Industry District	2.6
2.5.3	RR Rural Residential District	2.8
2.5.4	L-1 Lake District	2.8
2.5.5	R-1 Single-family Residential District.....	2.8
2.5.6	R-2 Single and Two-family Residential District	2.9
2.5.7	R-3 Multi-family Residential District	2.9
2.5.8	R-4 Mobile & Manufactured Home Park Residential District	2.9
2.5.9	B-1 Neighborhood Business District	2.9
2.5.10	B-2 General Business District.....	2.9
2.5.11	B-3 Highway Business District.....	2.10
2.5.12	B-4 General Business Dense Development District.....	2.10
2.5.13	B-5 Transitional Business District.....	2.10
2.5.14	I-1 Light Industrial District	2.10
2.5.15	I-2 Heavy Industrial District.....	2.11
2.5.16	I-3 Industrial Park District.....	2.11
2.5.17	AED Amusement and Entertainment District	2.11
2.5.18	Overlay Districts	2.12

CHAPTER 3: SPECIFIC USE REQUIREMENTS AND PERFORMANCE STANDARDS

3.0	Lot Requirements	3.1
3.0.1	Lots	3.1
3.0.2	Number of principle buildings per lot.....	3.1
3.0.3	Division of lots	3.2
3.0.4	Corner lots.....	3.2
3.0.5	Street frontage and access.....	3.2
3.0.6	Lot area exclusions	3.2
3.0.7	Vision clearance triangle	3.2
	Figure 3.1 – Vision Clearance Triangle; Street & Road Intersections.....	3.3
	Figure 3.2 – Vision Clearance Triangle; Adjacent to a Railroad Crossing.....	3.4
	Figure 3.3 – Vision Clearance Triangle; Street or Road & Alley Intersection.....	3.5
	Figure 3.4 – Vision Clearance Triangle; Driveway.....	3.6
3.1	Home Occupations	3.6
3.1.1	Purpose and scope	3.6
3.1.2	Required conditions.....	3.7
3.1.3	Uses that are prohibited as home occupations	3.8
3.1.4	Examples of uses that frequently qualify as home occupations	3.8
3.1.5	Professional offices – special restrictions	3.9

3.1.6	Child care homes – special restrictions	3.9
3.2	Bed and Breakfast Establishments	3.11
3.2.1	Location	3.11
3.2.2	Health regulations	3.11
3.2.3	Ancillary commercial use prohibited	3.11
3.2.4	Classification of use	3.11
3.2.5	Number of rooms permitted.....	3.11
3.2.6	Length of stay.....	3.11
3.2.7	Operator requirement	3.11
3.2.8	Parking requirement	3.11
3.3	Manufactured and Mobile Homes	3.11
3.3.1	Type I Manufactured Homes	3.12
3.3.2	Type II Manufactured Homes	3.12
3.4	Temporary Manufactured or Mobile Homes	3.13
3.4.1	Temporary residence during home construction.....	3.13
3.4.2	Temporary residence for a care-giver/dependent relative.....	3.14
3.5	Mobile Home Parks and Subdivisions	3.14
3.5.1	Entrance and interior roads	3.14
3.5.2	Compliance verification	3.15
3.6	Campgrounds	3.15
3.6.1	Minimum size	3.15
3.6.2	Occupation of tents, cabins and recreational vehicles	3.15
3.6.3	Campground standards.....	3.15
3.7	Recreational Vehicle Park.....	3.16
3.7.1	Minimum size	3.16
3.7.2	Entrances and interior roads.....	3.16
3.7.3	Recreational vehicle park standards.....	3.17
3.7.4	All recreational vehicle parks shall meet the following standards.....	3.17
3.7.5	Site plan requirements.....	3.17
3.8	Satellite Dish Antenna.....	3.17
3.8.1	General purposes.....	3.17
3.8.2	General requirements.....	3.18
3.9	Amateur Radio Antenna.....	3.19
3.10	Wireless Communications Facilities (“Facilities”)	3.19
3.10.1	Purpose, authority and jurisdiction.....	3.19
3.10.2	New Wireless Support Structures and Wireless Facilities.....	3.21
3.10.2.1	Application and Approval Procedure.....	3.21
3.10.2.2	General approval standards	3.24
3.10.2.3	General performance standards.....	3.26
3.10.3	Existing Wireless Support Structures and/or Wireless Facility Modification	3.28

3.10.3.1	Application and Approval Procedure-Modifications, Site Improvement Upgrades, Facilities Alteration/Upgrade & Equipment Revisions.....	3.27
3.10.4	Application and Approval Procedure – Collocations.....	3.30
3.10.5	Construction, Placement or Use of Small Cell Facilities.....	3.31
3.11	Extractive Manufacturing.....	3.34
3.12	Digesters, Aerobic or Anaerobic.....	3.35
3.13	Hospital and Medical, Mental Health Facility (Or Psychiatric Hospital)	3.38
3.14	I-3 Zoning District.....	3.38
3.15	General Performance Standards	3.41
3.15.1	Authority	3.42
3.15.2	Compliance	3.42
3.15.3	Enforcement.....	3.42
3.15.4	Exceptions.....	3.42
3.15.5	General provisions	3.42
3.16	Special Exception use Criteria and Requirements	3.43
3.16.1	<u>Category 1</u> : Adult entertainment business; tattoo parlor	3.43
3.16.2	<u>Category 2</u> : Agricultural industry; agricultural research firm; asphalt plant (manufacturing); bottled gas storage & distribution yard; construction, heavy contractors; ethanol or other similar bio-processing plant; explosives, use or storage; hatchery, commercial; hazardous waste landfill/facility; incinerator; industrial waste facility; junkyard; landfill; recycling facility; scrap metal yard; sewage treatment plant, private; slaughter house.....	3.44
3.16.3	<u>Category 3-A</u> : Airport; correctional/penal facility/prison; railroad facilities ..	3.45
3.16.4	<u>Category 3-B</u> : Heliport.....	3.46
3.16.5	<u>Category 4</u> : Bed & breakfast establishment; boarding/rooming house	3.46
3.16.6	<u>Category 5</u> : Restaurant drive-thru; retail establishment (0-99,000 GSF)....	3.47
3.16.7	<u>Category 6</u> : Auction arena or sales barn (for livestock); driving range; golf course; neighborhood facility; recreational facility, indoor; recreational facility, outdoor, commercial; shooting range, indoor; shooting range, outdoor; stable or boarding, commercial; stadium, coliseum, athletic field - commercial; theater, outdoor	3.48
3.16.8	<u>Category 7</u> : Boat storage (commercial); bus garage; bus station, passenger; truck freight terminal; truck stop; truck wash; veterinary clinic	3.48
3.16.9	<u>Category 8</u> : Vacation home (aka: Vacation Rental, Holiday Home, Holiday Apartment, Tourist Home (VRBO))/Cabins	3.49
3.16.10	<u>Category 9</u> : Event Barns.....	3.50
3.17	CFO AND CAFO ADDITIONAL DEVELOPMENTAL AND USE STANDARDS FOR ALL A-1 & I-2 DISTRICTS.....	3.51
3.17.1 – 3.17.2	Setbacks.....	3.51
3.17.3	IDEM.....	3.52
3.18	Odor Control Systems and Standards.....	3.52

3.18.1 Persons Responsible/Liable, Authority, Scope and Exclusions & Exemptions.....3.52

3.18.2 OCP Submission Requirements.....3.53

3.18.3 Fees.....3.53

3.18.4 Plan Compliance.....3.53

3.18.5 Violations.....3.53

3.18.6 Complaints.....3.54

3.18.7 Complaint Threshold.....3.54

3.18.8 Responsibility.....3.54

3.18.9 Standards.....3.54

3.18.10 Certification of Compliance.....3.54

3.18.11 Confirmation of Compliance Certificate.....3.55

3.18.12 Existing Sites.....3.55

3.19 Broadband Project Application Procedure 3.19-1 thru 3.19-83.56

CHAPTER 4: USE CLASSIFICATIONS AND PROVISIONS

4.0 Purpose and Intent4.1

4.1 Applicability4.1

4.2 Explanation of Use Classifications.....4.1

4.2.1 Official Schedule of Uses4.1

4.2.2 Permitted uses4.1

4.2.3 Special exception uses.....4.1

4.2.4 Accessory uses and structures.....4.2

4.2.5 Temporary uses and structures.....4.2

4.2.6 Nonconforming uses, structures, and uses and structures in combination..4.2

4.3 Accessory Use Provisions4.2

4.3.1 General provisions4.2

4.3.2 Domesticated animals4.2

4.3.3 Exotic animals.....4.2

4.3.4 Livestock animals & Bees.....4.2

4.3.5 Swimming pools4.4

4.3.6 Management offices4.4

4.3.7 Use, storage or parking of recreational vehicles4.4

4.4 Temporary Uses4.6

4.4.1 General provisions4.6

4.4.2 Standards.....4.7

4.5 Nonconforming uses and structures4.8

4.5.1 General provisions4.8

4.5.2 Single nonconforming lots of record4.9

4.5.3 Nonconforming lots of record in combination.....4.9

4.5.4 Nonconforming uses of land.....4.9

4.5.5	Nonconforming structures	4.10
4.5.6	Nonconforming uses of structures or structures and land in combination ..	4.10
4.5.7	Nonconforming districts	4.10
4.5.8	Nonconforming manufactured and mobile homes.....	4.11
4.5.9	Nonconforming decks – lake properties.....	4.13

CHAPTER 5: PLANNED UNIT DEVELOPMENT

5.0	Purpose and Intent	5.1
5.0.1	Purpose.....	5.1
5.0.2	Intent	5.1
5.1	Rezoning to a PUD	5.2
5.2	Requirements for a PUD	5.2
5.2.1	Ownership.....	5.2
5.2.2	Preliminary PUD Plan.....	5.2
5.2.3	Final PUD Plan.....	5.2
5.2.4	Compliance with this Ordinance	5.2
5.2.5	Permitted uses	5.3
5.3	PUD Submittal and Approval Process	5.3
5.3.1	Procedures for Preliminary PUD Plan.....	5.3
5.3.2	Amendments to an approved Preliminary PUD Plan	5.7
5.3.3	Procedures for Final PUD Plan.....	5.8
5.4	Final Plan Approval Not Acceptance of Dedication Offers	5.12
5.5	Financial Assurance Requirements	5.12
5.6	Recording the Final PUD Plan.....	5.12
5.7	Procedures for Platting a PUD	5.12
5.8	Failure to Initiate Construction after Final Development Plan Approval	5.12
5.8.1	Invalid projects	5.12
5.8.2	Extensions.....	5.13
5.8.3	Abandonment.....	5.13
5.9	As-Built Plans Requirement	5.13
5.10	Limitation of Rezoning.....	5.13
5.11	Proceedings for Enforcement	5.13
5.12	Fees.....	5.14
5.13	Penalties	5.14

CHAPTER 6: OVERLAY DISTRICTS

6.0	Purpose and Intent	6.1
6.1	Ordinance Repeal	6.1
6.2	Conservation and Flood Plain Overlay District	6.1
6.2.2	Regulations.....	6.1

6.2.3	District Boundaries.....	6.2
-------	--------------------------	-----

CHAPTER 7: RENEWABLE ENERGY SYSTEMS

WIND AND SOLAR SITING REGULATIONS

7.0	Purpose and Intent	7.1
7.0.1	Purpose.....	7.1
7.0.2	Intent	7.1
7.1	Applicability	7.1
7.2	Prohibition.....	7.1
7.3	Conflict with Other Regulations.....	7.1
7.4	District Regulations- WECS.....	7.2
7.4.1	Location	7.2
7.4.2	Height.....	7.2
7.5	Setback Requirements.....	7.3
7.5.1	Minimum setback distances for Commercial WECS Towers.....	7.3
7.5.2	Commercial WECS Power Collection and Transmission System	7.5
7.5.3	Minimum setback distances for Non-Commercial and Micro-WECS Towers.....	7.6
7.5.4	Horizontal extension for Non-commercial and Micro WECS	7.7
7.5.5	Minimum setback distances for all Meteorological Towers	7.7
7.5.6	Horizontal extension for all Meteorological Towers.....	7.7
7.6	Safety Design and Installation Standards.....	7.8
7.6.1	Equipment type	7.8
7.6.2	Industry standards and other regulations.....	7.8
7.6.3	Controls and brakes	7.8
7.6.4	Electrical components	7.8
7.6.5	Color and finish	7.9
7.6.6	Warnings.....	7.9
7.6.7	Climb prevention	7.10
7.6.8	Blade clearance.....	7.10
7.6.9	Lighting	7.10
7.6.10	Materials handling, storage and disposal.....	7.11
7.7	Other Applicable Standards	7.11
7.7.1	Guyed wire anchors	7.11
7.7.2	Sewer and water	7.11
7.7.3	Noise and vibration.....	7.11
7.7.4	Utility interconnection	7.11
7.7.5	Signage.....	7.11
7.7.6	Feeder lines	7.12
7.7.7	Other appurtenances.....	7.12
7.8	Operation and Maintenance	7.12
7.8.1	Physical modifications	7.12
7.8.2	Interference.....	7.12

7.8.3	Declaration of public nuisance	7.13
7.9	Decommissioning Plan	7.13
7.9.1	Content	7.13
7.9.2	Discontinuation and abandonment	7.14
7.9.3	Removal	7.14
7.9.4	Written notices.....	7.14
7.9.5	Costs incurred by the County	7.14
7.10	Liability Insurance	7.14
7.11	Application Procedures	7.15
7.11.1	Applications for all Wind Energy Conversion Systems Projects	7.15
7.11.2	Applications for non-commercial WECS	7.17
7.11.3	Applications for commercial WECS	7.17
7.11.4	Applications for all Meteorological Towers.....	7.19
7.11.5	Aggregated project applications	7.19
7.11.6	Fees	7.19
7.11.7	Permits.....	7.20
7.12	Pre-construction Requirements.....	7.20
7.12.1	FAA permit application	7.20
7.12.2	Decommissioning Plan	7.20
7.12.3	Econ Dev, Drainage, and Road Use & Maintenance Agreement	7.20
7.12.4	Erosion control plan.....	7.21
7.12.5	Utility plan.....	7.21
7.12.6	Avoidance and mitigation of damages to public infrastructure	7.21
7.13	Construction Requirements	7.21
7.13.1	Dust control.....	7.21
7.13.2	Drainage.....	7.21
7.14	Post-construction Requirements.....	7.22
7.14.1	Road repairs.....	7.22
7.14.2	As-Built Plans Requirement.....	7.22
7.14.3	Change in ownership.....	7.22
7.15	Commercial, Individual and Shared Solar Energy Systems	7.22
7.15.1	Purpose, Persons Liable, Authority, Scope and Exclusions & Exemptions.....	7.22
7.16	Application Requirements	7.24
7.17	District Regulations & Performance Standards	7.26
7.18	Commercial Solar Energy System’s Collection and Transmission System	7.31
7.19	Battery Storage Fields and Battery Storage Retrofits.....	7.31
7.19	District Regulations and Performance Standards for Battery Storage Fields (BSF).....	7.35

CHAPTER 8: PARKING AND LOADING STANDARDS

8.0	Purpose and Intent	8.1
8.1	General Standards.....	8.1

8.1.1	Minimum parking and loading requirements	8.1
8.1.2	Parking and loading for uses which have been intensified	8.1
8.1.3	Parking and loading for buildings which have been converted.....	8.1
8.1.4	Reduction in existing parking and loading facilities	8.1
8.2	Applicability	8.1
8.2.1	On-street parking.....	8.2
8.2.2	Location of accessory off-street parking and loading facilities.....	8.2
8.2.3	Off-street parking facilities-prohibition.....	8.2
8.2.4	Sharing of off-street parking facilities.....	8.2
8.2.5	Off-street loading and unloading spaces as they relate to required off-street parking	8.2
8.2.6	Exception for loading and unloading berths	8.2
8.3	Existing Parking & Loading Areas.....	8.3
8.3.1	Use of existing parking and loading areas	8.3
8.3.2	Parking and loading areas damaged or destroyed.....	8.3
8.3.3	Parking and loading areas servicing damaged or destroyed conforming or legally nonconforming buildings or structures.....	8.3
8.4	Shared Parking	8.3
8.4.1	Shared parking for uses with similar hours of operation.....	8.3
8.4.2	Shared parking for uses which operate at different hours of the day.....	8.3
8.4.3	Shared parking, temporary uses	8.4
8.5	Parking Spaces Accessible to the Disabled	8.4
8.5.1	Required spaces	8.4
8.5.2	General ADA design and layout requirements.....	8.5
8.5.3	Design deviation.....	8.5
8.5.4	ADA loading zones.....	8.6
8.5.5	Location	8.6
8.5.6	Signage and marking.....	8.6
	Table 8.1 Parking Spaces Accessible to the Disabled.....	8.7
8.6	Parking Development Standards	8.7
8.6.1	Dimensions	8.8
	Tale 8.2 Minimum Space & Aisle Dimensions of Parking Spaces.....	8.9
8.6.2	Layout and design	8.9
8.6.2.1	Driveways, parking spaces and back out aisles, additional standards.....	8.10
8.6.3	Surfacing and drainage	8.14
8.7	Parking and Storage of Certain Vehicles	8.15
8.7.1	Nuisance vehicles	8.15
8.7.2	Commercial vehicles	8.15
8.7.3	Temporary/portable storage units.....	8.15
8.8	Design Flexibility	8.16
8.8.1	Reduction of parking	8.16
8.8.2	Phasing of minimum parking requirements.....	8.16
8.8.3	Deviation from minimum parking requirements.....	8.16
8.9	Drive-Through and service point Stacking Space Requirements	8.17

8.9.1 Stacking lane dimensions and markings.....8.17

8.9.2 Number of stacking spaces8.17

Table 8.3 Minimum Required Vehicle Stacking Spaces.....8.17

8.10 Loading Space Requirements8.18

Table 8.4 Loading Space Requirements.....8.18

8.10.1 Location8.18

8.10.2 Size8.19

8.10.3 Surface.....8.20

8.10.4 Minimum setback distances for certain parking & loading spaces.....8.20

Table 8.5 – Minimum Setback Distances for Certain Parking/Loading Areas8.21

8.11 Additional Requirements for Off-Street Parking & Loading Plans.....8.21

8.11.1 Off-street parking and loading plan.....8.21

8.11.2 Lease or easement.....8.22

8.11.3 Setbacks8.22

8.11.4 Minimum number of spaces required.....8.22

8.11.5 Calculating the minimum number of spaces required8.22

8.11.6 Administrative adjustment8.23

8.12 Electric vehicle charging stations.....8.23

8.12.1 General Requirements8.24

Table 8.6 - Required off-street parking spaces listing.....8.26

CHAPTER 9: LANDSCAPING STANDARDS

9.0 Purpose and Intent9.1

9.1 Applicability9.1

9.2 Landscape Plan Requirement9.1

9.2.1 Preparation..... 9.1

9.2.2 Content 9.2

9.3 General Landscaping Requirements9.2

9.3.1 Agricultural Districts..... 9.2

9.3.2 Placement of trees 9.2

9.3.3 Vision clearance areas 9.3

9.3.4 Parking lot landscaping requirements..... 9.3

9.3.5 Protection of landscaped areas 9.3

9.3.6 Screening of outdoor activities..... 9.4

9.3.7 Screening requirements for wireless communications facilities..... 9.4

9.3.8 Screening of refuse and recycling areas..... 9.4

9.3.9 Screening requirements for service structures..... 9.5

9.3.10 Detention/retention basins and ponds 9.5

9.3.11 Preservation 9.5

9.4 Approved Landscaping Materials9.5

9.4.1 Trees..... 9.5

9.4.2 Shrubs and vines..... 9.6

9.4.3	Ground cover	9.6
9.4.4	Screening materials.....	9.6
9.5	Installation and Maintenance	9.7
9.5.1	Trees.....	9.7
9.5.2	Responsible party.....	9.7
9.5.3	Dead, dying or damaged plant materials	9.7
9.6	Fencing.....	9.7
9.6.1	Construction materials.....	9.8
9.6.2	Height.....	9.8
9.6.3	Front yard limitations for residential uses.....	9.8
9.6.4	Decorative fences for residential uses	9.8
9.6.5	Non-residential fences.....	9.8
9.6.6	Municipal Regulations.....	9.9
	Table 9:1 Landscaping requirements.....	9.10

CHAPTER 10: SIGN STANDARDS

10.0	Purpose and Intent	10.1
10.0.1	Purpose.....	10.1
10.0.2	Intent	10.1
10.1	Sign Permits.....	10.1
10.1.1	Sign permit requirement	10.1
10.1.2	Information required for sign permit	10.1
10.1.3	Permit fees	10.2
10.1.4	Expiration of permit	10.2
10.1.5	Effect of sign permit issuance.....	10.2
10.1.6	Permit revocation	10.2
10.2	General Requirements for All Signs.....	10.3
10.2.1	Display of permit.....	10.3
10.2.2	Responsibility	10.3
10.2.3	Maintenance.....	10.3
10.2.4	Removal.....	10.3
10.3	General Sign Regulations.....	10.3
10.3.1	Location	10.3
10.3.2	Sign projection.....	10.4
10.3.3	Movement or simulated motion.....	10.4
10.3.4	Prohibitions	10.4
10.3.5	Emissions	10.5
10.3.6	Visual impairment	10.5
10.3.7	Obstruction	10.5
10.3.8	Prohibitions-State or Federal law or regulation.....	10.5
10.3.9	Sign components	10.5
10.4	Illumination.....	10.5
10.4.1	National standards	10.5
10.4.2	Condition.....	10.5

10.4.3	Reflection	10.6
10.4.4	Shielding	10.6
10.4.5	Electronic messaging (EM)	10.6
10.5	Maintenance and Removal	10.7
10.5.1	Inspection.....	10.7
10.5.2	Removal of signs.....	10.7
10.5.3	Maintenance.....	10.8
10.5.4	Abandoned signs.....	10.8
10.6	Determining the Measurements of a Sign.....	10.8
10.6.1	Sign area.....	10.8
10.6.2	Back-to-back signs	10.8
10.6.3	Sign height	10.8
	Table 10:1 Determining the Measurement of a Sign.....	10.9
10.7	Sign Standards for Residential Zoning Districts.....	10.9
10.7.1	Applicable districts.....	10.9
10.7.2	L-1, R-1, R-2 & R-4 Residential Districts Used For Single Family Dwelling or Two Family Dwelling Purposes.....	10.9
10.7.3	R-3 & R-4 Residential Districts Used For Multi-Family Dwelling Units or Manufactured Home Park Purposes.....	10.10
10.7.4	All residential districts used for institutional purposes	10.11
	Table 10.1 Permanent identification sign regulations for all residential districts.....	10.11
10.8	Standards for Commercial and Industrial Zoning Districts.....	10.11
10.8.1	Applicable Districts	10.11
	Table 10.2 Sign Regulations for Commercial and Industrial Districts.....	10.12
10.8.2	I-3	10.14
10.8.3	Shared advertising signs.....	10.14
10.8.4	Roof signs.....	10.15
	Figure 10.2 Shared Advertising Sign.....	10.15
10.9	Off Premise Signs.....	10.16
10.9.1	State permitting compliance	10.16
10.9.2	Billboards, location	10.16
10.9.3	Billboards, spacing and size, lighting	10.16
10.9.4	Billboards, digital	10.17
10.9.5	Yard signs (off-premise only).....	10.17
10.9.6	Disposable signs (off-premise only).....	10.18
10.9.7	Signs on farm property.....	10.19
10.9.8	Other off-premise signs.....	10.19
10.10	Legal Nonconforming Signs.....	10.19
10.10.1	Exception	10.19
10.10.2	Maintenance and repair.....	10.19

10.10.3	Improvements	10.19
10.10.4	Destroyed or damaged	10.20
10.11	Prohibited Signs	10.20
10.11.1	Search lights	10.20
10.11.2	Tower & WECS signs	10.20
10.11.3	Signs similar to emergency or traffic functions	10.20
10.11.4	Signs which obstruct	10.20
10.11.5	Other signs	10.20
10.12	Exempt Signs	10.20
10.12.1	Cylindrical Poles	10.21
10.12.2	Agricultural signs	10.22
10.12.3	Drive-through boards	10.22
10.12.4	Feather flag banners	10.22
10.12.5	Flags	10.22
10.12.6	Historical location signs	10.22
10.12.7	Government signs	10.22
10.12.8	Integral signs	10.23
10.12.9	Incidental parking lot signs	10.23
10.12.10	Incidental signage, other	10.24
10.12.11	Yard signs – on premise	10.24
10.12.12	Disposable signs – on premise	10.24
10.12.13	Suspended signs	10.24
10.12.14	Window signs and signs viewable through a window	10.25
10.12.15	A-frame and T-frame signs	10.25
10.12.16	Decorative signs (banners, lights, balloons, pennants and streamers)	10.25
10.12.17	Community service central displays/Community adoption signs	10.25
10.12.18	Bench signs	10.26
10.12.19	Changeable copy signs, portable	10.26
10.12.20	Neighborhood watch and similar community awareness signs	10.26
10.12.21	Barn Quilt Signs	10.27
10.12.22	Water tower signs	10.27
10.12.23	Retail signage	10.27
10.12.24	Natural composite signs	10.27
10.12.25	Vehicle signs	10.28
10.12.26	Murals, wall graphics and works of art	10.28
10.12.27	Public signs	10.28
10.12.28	Utility marker signs	10.28
10.12.29	Park or athletic field fence signage, wall signage and scoreboard signage, subject to the standards listed below	10.28
10.13	Temporary Signs	10.28

CHAPTER 11: ADMINISTRATIVE BODIES AND OFFICIALS

11.0	Summary of Authority	11.1
11.1	Bodies and Officials	11.1
11.1.1	County Commissioners	11.1
11.1.2	Municipal legislative bodies	11.1

11.1.3	Area Plan Commission	11.2
11.1.4	Board of Zoning Appeals	11.4
11.1.5	Technical Review Committee	11.6
11.1.6	Hearing Examiner.....	11.8
11.1.7	Hearing Officer.....	11.8
11.1.8	Plat Committee.....	11.8

CHAPTER 12: ADMINISTRATION

12.0	Application and Permit Types	12.1
12.0.1	Petition applications required.....	12.1
12.0.2	Applications, general	12.1
12.1	Official Fee Schedule	12.2
12.1.1	Maintenance.....	12.2
12.1.2	Availability	12.3
12.1.3	Responsibility of payment.....	12.3
12.1.4	Payment in full.....	12.3
12.1.5	Contracting of independent professionals.....	12.3
12.2	Public Hearings and Meetings	12.3
12.2.1	Setting a hearing or meeting.....	12.3
12.2.2	Review of application materials	12.4
12.2.3	Conduct of hearings	12.4
12.2.4	Examination and copying of application and other documents.....	12.4
12.3	Successive Applications (Petitions), Appeals.....	12.5
12.3.1	Second applications barred without new grounds.....	12.5
12.3.2	New grounds to be stated.....	12.5
12.3.3	Summary denial with or without hearing	12.5
12.3.4	Exception	12.5
12.4	Development Standards Variance	12.5
12.4.1	Authority	12.6
12.4.2	Burden of proof.....	12.6
12.4.3	Application.....	12.6
12.4.4	Notification	12.6
12.4.5	Action by Executive Director.....	12.6
12.4.6	Public hearing	12.7
12.4.7	Decision criteria prescribed by state law.....	12.7
12.4.8	Additional decision criteria.....	12.7
12.4.9	Written Findings of Fact.....	12.8
12.4.10	Conditions and/or commitments	12.8
12.4.11	Limitation.....	12.9
12.4.12	Termination	12.10
12.4.13	Revocation of a variance	12.10
12.4.14	Appeals	12.11
12.5	Special Exception Use Permit.....	12.11
12.5.1	Authority	12.11
12.5.2	No presumption of approval	12.11

12.5.3	Application.....	12.12
12.5.4	Notification	12.12
12.5.5	Action by the Executive Director.....	12.12
12.5.6	Public hearing	12.12
12.5.7	Decision criteria.....	12.12
12.5.8	Additional decision criteria.....	12.13
12.5.9	Possible action by the Area Board of Zoning Appeals	12.13
12.5.10	Written Findings of Fact.....	12.14
12.5.11	Conditions and/or commitments	12.14
12.5.12	Limitation.....	12.15
12.5.13	Termination	12.16
12.5.14	Appeals	12.16
12.6	Appeal of an Administrative Decision.....	12.17
12.6.1	Purpose.....	12.17
12.6.2	Authority	12.17
12.6.3	Parties entitled to appeal.....	12.18
12.6.4	Application.....	12.18
12.6.5	Action by the Executive Director.....	12.18
12.6.6	Notification	12.18
12.6.7	Possible action by the Board of Zoning Appeals.....	12.18
12.6.8	Review by judicial review.....	12.19
12.6.9	Right to grant variance in deciding appeals	12.19
12.6.10	Conditions and limitations on rights granted by appeal.....	12.19
12.7	Zoning Ordinance Amendment.....	12.19
12.7.1	Purpose.....	12.19
12.7.2	Authority	12.20
12.7.3	Parties entitled to initiate amendments	12.20
12.7.4	Approval.....	12.20
12.8	Zoning Map Amendment (Rezoning).....	12.21
12.8.1	Purpose.....	12.21
12.8.2	Authority	12.22
12.8.3	Parties entitled to initiate amendments	12.22
12.8.4	Application.....	12.23
12.8.5	Notification	12.23
12.8.6	Public hearing	12.23
12.8.7	Decision criteria.....	12.23
12.8.8	Possible action by the Area Plan Commission.....	12.24
12.8.9	Certification by the Area Plan Commission.....	12.25
12.8.10	Possible action by the appropriate legislative body.....	12.25
12.8.11	Effective date	12.25
12.8.12	Written commitments.....	12.25
12.9	Zoning Ordinance Interpretation.....	12.26
12.9.1	Authority	12.27
12.9.2	Parties entitled to seek interpretations	12.27
12.9.3	Application requests	12.27
12.9.4	Decision criteria.....	12.27

12.9.5	Possible action by the Executive Director	12.27
12.9.6	Recording.....	12.28
12.9.7	Limitations on use interpretations	12.28
12.9.8	Appeals	12.28
12.10	Planned Unit Development	12.28
12.11	Improvement Location Permit.....	12.28
12.11.1	Improvement Location Permit required.....	12.28
12.11.2	Improvement Location Permit not required	12.29
12.11.3	Application.....	12.30
12.11.4	Action by the Executive Director (and/or his or her designee).....	12.30
12.11.5	Expiration of an Improvement Location Permit	12.31
12.11.6	Failure to obtain an Improvement Location Permit.....	12.31
12.11.7	Limitations.....	12.31
12.11.8	Recording.....	12.31
12.12	Certificate of Occupancy Permit	12.32
12.12.1	Issuance and recording	12.32
12.12.2	Failure to obtain a Certificate of Occupancy Permit	12.32
12.13	Site Development Plan Review	12.32
12.13.1	Purpose.....	12.32
12.13.2	Applicability and authority	12.33
12.13.3	Initiation.....	12.33
12.13.4	Submission.....	12.33
12.13.5	Content Requirements.....	12.33
12.13.6	Administrative procedures	12.36
12.13.7	Notice.....	12.37
12.13.8	Action on site development plans	12.37
12.13.9	Standards for site development plan review	12.37
12.13.10	Conditions on plans.....	12.39
12.13.11	Public improvement performance guarantees	12.39
12.14	Written Commitments	12.39
12.14.1	Purpose, intent and authority.....	12.39
12.14.2	Commitments for rezoning or PUD proposal	12.40
12.14.3	Standard forms.....	12.40
12.14.4	Binding effect	12.40
12.14.5	Effective date of commitment	12.41
12.14.6	Covenant running with the land	12.41
12.14.7	Enforcement.....	12.41
12.14.8	Recording.....	12.41
12.14.9	Modification and termination.....	12.42
12.14.10	Public notice.....	12.42
12.14.11	Validity of other land use restrictions	12.42
12.15	Zoning Hearing Officer and Alternate Procedure.....	12.42
12.15.1	Authorization of the Area Plan Hearing Officer	12.42
12.15.2	Recommendation of the Area Plan Hearing Officer and Alternate	12.42
12.15.3	Approval of the Area Plan Hearing Officer and Alternate Recommendations	12.43

12.15.4	Powers and Duties of Zoning Hearing Officer.....	12.43
12.15.5	Alternate Procedure	12.43
12.16	Addressing, Road/Street/Alley Naming & Bridge Dedications	12.43
12.16.1	Purpose and intent	12.43
12.16.2	Applicability	12.43
12.16.3	Definitions	12.43
12.16.4	Ordinance Repeal	12.44
12.16.5	Bridge Dedications	12.44
12.16.6	Addressing	12.44
12.16.7	Street/Road/Alley Name Assignments or Changes.....	12.46

CHAPTER 13: ENFORCEMENT

13.0	General Provisions	13.1
13.0.1	Authority	13.1
13.0.2	County.....	13.1
13.0.3	Area Plan Commission	13.1
13.0.4	Persons Liable.....	13.1
13.0.5	Right of Entry	13.1
13.0.6	Stop Work Order	13.1
13.1	Civil Zoning Violations.....	13.2
13.1.1	Enforcement Procedures.....	13.2
13.1.2	Enforcement Without Prior Notice	13.2
13.1.3	Warning Ticket	13.2
13.1.4	Citations	13.3
13.1.5	Appeals	13.5
13.1.6	Trial	13.6

CHAPTER 14: DEFINITIONS

14.0	Purpose and Intent	14.1
14.1	Rules	14.1
14.1.1	Word tense.....	14.1
14.1.2	Persons and other responsible parties	14.1
14.1.3	Masculine vs. feminine	14.1
14.1.4	Distinguishing between what is mandatory, permissive & preferred.....	14.2
14.1.5	Using and occupying a space.....	14.2
14.1.6	Lot, plot or parcel.....	14.2
14.1.7	Time	14.2
14.1.8	Captions, illustrations and tables	14.2
14.2	Words and Phrases Defined.....	14.2

APPENDICES

Appendix A: Official Schedule of Uses	A.1
Appendix B: Bulk Use Standards	B.1

Appendix C: Recommended Plant Materials C.1
Appendix D: Process Charts D.1

.....



CHAPTER 1 GENERAL PROVISIONS

1.0 TITLE

These regulations shall hereafter be known and cited as the White County, Indiana Zoning Ordinance.

1.1 PURPOSE AND INTENT

1.1.1 Purpose

The purpose of this Ordinance is to regulate and control the use and development of land within the jurisdictions of the White County Area Plan Commission.

1.1.2 Intent

The intent of this Ordinance is to promote the public health, safety and general welfare and more specifically to:

- A. Support the goals, objectives and policies of the White County Comprehensive Plan and other plans adopted by the County and participating municipalities;
- B. Provide for efficient development of natural resources, agriculture, business and industry;
- C. Provide for the conservation of property values and natural resources;
- D. Provide for the growth of the county, city, and towns commensurate with the efficient and economical use of public funds in such areas that are under the jurisdiction of the White County Area Plan Commission;
- E. Identify the boundaries of zoning districts, by reference to the official zoning map;
- F. Prohibit uses, buildings or structures which are incompatible with the stated purpose of the district in which it is located or proposed;
- G. Create and establish standards to which the uses, buildings or structures within each district shall conform therein restricting and regulating their location, construction, reconstruction or alteration;
- H. Regulate the intensity of each lot by requiring open space areas around buildings and structures and further providing adequate safety, light, and ventilation;
- I. Limit congestion on public roadways;
- J. Preserve and enhance features of environmental or historic significance;
- K. Designate and define the powers and duties of the bodies and/or officials administering and enforcing this Ordinance and the White County, Indiana Subdivision Control Ordinance and the procedures by which this Ordinance is administered; and
- L. Prescribe penalties for the violation of this Ordinance.

1.2 AUTHORITY

This Ordinance is adopted by White County pursuant to its authority under the laws of the State of Indiana, IC 36-7-4 et seq. Whenever codes cited in this Ordinance refer to Indiana Code (IC) where the state statute has been amended or superseded, this Ordinance shall be deemed amended in reference to the new or revised Indiana Code.

1.3 JURISDICTION

The provisions, standards and regulations of this Ordinance shall apply to all land within White County, except for those areas under the jurisdiction of a city or town that is not a member of the White County Area Plan Commission pursuant to IC 36-7-4-201(b).

1.4 UNIFORMITY

Those portions of the text which include the name or names of one or several of the adopting jurisdictions (in capital letters and within parentheses) are effective in those specific jurisdictions only. All other portions of the text are effective in all jurisdictions.

1.5 INTERPRETATION

1.5.1 Minimum requirements

In their interpretation and application, the provisions of these regulations shall be held to be the minimum requirements for the promotion of the public health, safety, and general welfare of the people at large, and are designed to encourage the establishment and maintenance of reasonable community standards for the physical environment.

1.5.2 Conflicting requirements

A. Zoning Ordinance provisions

If two or more provisions within this Ordinance conflict, or are otherwise inconsistent with one another, then the provision which is most restrictive, or imposes higher standards, shall govern.

B. Public provisions

These regulations are not intended to interfere with, abrogate, or annul any other ordinance, rule or regulation, statute, or other provision of law. Where any provision of these regulations imposes restrictions different from those imposed by any other provision of these regulations or any other ordinance, rule or regulation, or other provision of law, those provisions which are more restrictive or impose higher standards shall govern.

C. Private provisions

These regulations are not intended to abrogate any easement, covenant or any other private agreement or restriction, provided that where the provisions of these regulations are more restrictive or impose higher standards or regulations than any easement, covenant, or other private agreement or restriction, the requirements of these regulations shall govern. Where the provisions of the easement, covenant, or private agreement or restriction impose duties and obligations more restrictive, or

higher standards than the requirements of these regulations or the determinations of the Commission in enforcing these regulations, and the private provisions are not inconsistent with these regulations or determinations hereunder, then the private provisions shall be operative and supplemental to these regulations, or the determinations made there under. Private provisions shall only be enforced privately.

1.5.3 Severability

If any part or provision of these regulations or application thereof to any person or circumstances is judged invalid by any court of competent jurisdiction, the judgment having been rendered shall not affect or impair the validity of the remainder of these regulations or the application thereof to other persons or circumstances. The legislative body hereby declares that it would have enacted the remainder of these regulations even without any part, provision or application.

1.5.4 Saving provision

Except as expressly provided for herein, this ordinance shall not be construed as either:

- A. Abating any action now pending under or by virtue of any preexisting ordinance; or
- B. Discontinuing, abating, modifying, or altering any penalty accruing or about to accrue; or
- C. Affecting the liability of any person, firm, or corporation; or
- D. Waiving any right of a participating jurisdiction under any section or provision existing at the time of the effective date of this ordinance; or
- E. Vacating or annulling any rights obtained by any person, firm, or corporation, by lawful action of the participating jurisdictions or administrative bodies thereof.

1.5.5 Exclusion

Nothing in this Ordinance or in any rules, regulations or orders issued pursuant to this Ordinance shall be deemed to restrict or regulate or to authorize any unit of government, legislative body, Plan Commission or Board of Zoning Appeals now or hereafter established, to restrict or regulate the exercise of the power of eminent domain by the state or by any state agency, or the use of property owned or occupied by the state or any state agency.

1.6 AMENDMENTS

For the purpose of providing for the public health, safety, and general welfare, the White County Commissioners or appropriate legislative body, on recommendation of the Area Plan Commission, may from time to time amend the text of this Ordinance and/or the Official Zoning Map incorporated by reference in this Ordinance. Public hearings on all proposed amendments shall be held in the manner prescribed by state law.

1.7 ADOPTION

The following is a record of the adoption procedure of this Ordinance, conducted by the White County Area Plan Commission, the City of Monticello, and the Towns of Brookston, Burnettsville, Chalmers, Monon, Reynolds, and Wolcott.

- A. Public hearings;
- B. Recommendation and certification by the Area Plan Commission;
- C. Adoption by governmental units:
 - 1. County of White;
 - 2. City of Monticello;
 - 3. Town of Brookston;
 - 4. Town of Burnettsville;
 - 5. Town of Chalmers;
 - 6. Town of Monon;
 - 7. Town of Reynolds; and
 - 8. Town of Wolcott.
- D. Recorded with the White County Recorder

1.8 EFFECTIVE DATE

This ordinance shall become effective on the date in which it is adopted by a given jurisdiction.

1.9 REPEAL OF PRE-EXISTING ZONING ORDINANCES

The Zoning Ordinances Number 97-12-5958 of White County, Number 12-28-94 of Brookston, Number 94-2 of Chalmers, Number 12-28-94 of Reynolds, Number 12-28-94 of Monticello, Dated December 6, 1994 of Burnettsville, Dated December 6, 1994 of Monon, and Dated December 6, 1994 of Wolcott is repealed by this Ordinance. Said repeal shall become effective on the effective date of this Ordinance.

CHAPTER 2 DISTRICT BOUNDARIES AND STANDARDS

2.0 OFFICIAL ZONING MAP

White County is divided into zoning districts as described and defined in this Ordinance and as shown on the Official Zoning Map. The Official Zoning Map, together with all explanatory matter thereon, is hereby adopted by reference and declared to be a part of this Ordinance.

2.0.1 Identification and Location

The Official Zoning Map shall be maintained electronically by the Staff and identified as GIS Zoning Map and be located on the White County Indiana official web site. The Official Zoning Map shall also include the ordinance number by which it was adopted and the date of adoption. The official zoning map shall be available for public inspection during county business hours in the office of the White County Area Plan Commission.

2.0.2 Final Authority

The Official Zoning Map shall be the final authority as to the current zoning status of land and water areas, buildings, and other structures within the jurisdiction of the White County Area Plan Commission.

2.0.3 Copies

Copies of the Official Zoning Map may be made and distributed to interested persons. All copies of the Official Zoning Map shall be labeled as copies and include the date on which it was obtained. The party requesting the copy shall bear the cost of each copy as listed in the Official Fee Schedule.

2.0.4 Amendment or replacement

No changes of any nature shall be made on the Official Zoning Map except in conformance with the procedures set forth in Chapter 12, Administration. Any unauthorized change by any person or persons shall be considered a violation of this Ordinance.

A. Amendment (Rezoning)

Upon the passage of a map amendment (rezoning), the County Commissioners or appropriate legislative body shall certify a copy of the amendment to the Executive Director. The Executive Director shall cause the change to be made to the Official Zoning Map in accordance with the amendment. The Executive Director shall cause the Official Zoning Map to show a notation electronically identifying the ordinance number, file number, and date of adoption by the appropriate legislative body.

B. Preservation of the prior Official Zoning Map

Unless the prior Official Zoning Map has been lost or has been totally destroyed, the prior map or any significant parts thereof shall be preserved, together with all available records pertaining to its adoption or amendment.

2.1 INTERPRETATION OF DISTRICT BOUNDARIES

2.1.1 Interpretation Standards

Zoning district boundaries illustrated on the Official Zoning Map shall be interpreted as follows:

A. Streets and easements

Boundaries shown within the lines of roads, easements, and transportation rights-of-way shall be deemed to follow the centerlines.

B. Property lines

Boundaries indicated as following section or fractional sectional lines, platted lot lines, or municipal corporation limits shall be construed to follow such lines.

C. Bodies of water

Boundaries indicated as approximately following the center line of streams, rivers, or other bodies of water shall be construed to follow such center lines. Boundaries indicated as following shore lines shall be construed as moving with any change in the actual shore line.

D. Divided lots

In the event that a boundary line divides a lot or parcel, the Executive Director shall determine the applicable zoning district. The Executive Director may require a rezone or replat of the site if any portion of a construction or development proposal overlaps two or more zoning districts. The petitioner shall be responsible for filing the appropriate forms and for applying the appropriate filing fees to rezone or replat the lot or parcel. If a portion of a lot or parcel is in an overlay district, the entire lot or parcel shall be deemed as being within the overlay district.

E. Extensions of lines

Boundaries indicated as parallel to or extensions of the features listed above in Section 2.101(A) through (D) shall be construed as such.

F. The Conservation and Flood Plain Overlay District boundaries

Boundaries of the Conservation and Flood Plain Overlay District shall coincide with the boundaries as documented on the Flood Insurance Rate Maps for White County.

2.1.2 Executive Director Interpretation

The Executive Director shall determine the applicable zoning for each property in the Area Plan Commission's jurisdiction. Any ruling of the Executive Director may be appealed to the Board of Zoning Appeals.

2.1.3 Plan Commission interpretation provision

If the Executive Director cannot definitively determine the location of a district boundary, immediate action on any affected application shall be delayed until such time when the Plan Commission determines the zoning district boundary. The Plan Commission shall interpret the location of the district boundary with reference to the scale of the Official

Zoning Map and the purposes set forth in all relevant provisions of this Ordinance. This interpretation may occur as part of a regular or special Plan Commission meeting and shall not require a public hearing. Decisions of the Plan Commission may not be appealed to the Board of Zoning Appeals, but may be appealed to a court of jurisdiction.

2.1.4 **Effect of vacation on zoning district boundaries**

Whenever any street, alley, public way, railroad right-of-way, or other similar area is vacated by the proper authority, the adjoining zoning districts shall be extended automatically to the center of the vacated area. All areas included in the vacation shall then be subject to all applicable regulations of the extended zoning district. In the event of a partial vacation, the adjoining zoning district, or the zoning district nearest the portion vacated, shall be extended automatically to include all of the vacated area.

2.2 **GENERAL STANDARDS AND REGULATIONS**

General standards and regulations for each district are prescribed as follows:

2.2.1 **Uses**

Permitted, accessory, temporary, special exception, and prohibited uses shall be as prescribed by Chapter 3, Specific Use Requirements and Performance Standards and Appendix A, Official Schedule of Uses.

2.2.2 **Bulk use standards**

As prescribed by the Bulk Use Standards Matrix located in Appendix B of this Ordinance

2.2.3 **Parking standards**

As prescribed by Chapter 8, Parking and Loading Standards.

2.2.4 **Landscaping standards**

As prescribed by Chapter 9, Landscaping Standards.

2.2.5 **Sign standards**

As prescribed by Chapter 10, Sign Standards.

2.3 **ESTABLISHMENT OF DISTRICTS**

All land within the jurisdiction of this ordinance is divided into the following types of districts:

- A. General Agriculture District (A-1)
- B. Agricultural Industry District (A-2)
- C. Rural Residential District (RR)
- D. Lake District (L-1)
- E. Single-family Residential District (R-1)

- F. Single and Two-family Residential District (R-2)
- G. Multi-family Residential District (R-3)
- H. Mobile Home Park Residential District (R-4)
- I. Neighborhood Business District (B-1)
- J. General Business District (B-2)
- K. Highway Business District (B-3)
- L. General Business Dense Development District (B-4)
- M. Transitional Business District (B-5)
- N. Light Industrial District (I-1)
- O. Heavy Industrial District (I-2)
- P. Industrial Park (I-3)
- Q. Amusement & Entertainment District (AED)
- R. Conservation and Flood Plain Overlay District (CFO)

2.4 DISTRICT CLASSIFICATIONS - GENERAL

Territory under the jurisdiction of the Area Plan Commission is divided into the following general land use classifications.

2.4.1 Agricultural districts

The primary use of land throughout much of the unincorporated area of White County is agricultural in nature. The A-1, A-2, and RR agricultural districts are hereby established to protect prime farmland and encourage agricultural industries, for the purpose of preserving the local economy. All residential development within the following agricultural districts should be limited in scale and density.

2.4.2 Residential districts

Conventional residential zoning districts are intended for residential dwellings and related recreational, religious, and educational facilities as these related land uses are typically viewed as providing a balanced and attractive residential neighborhood. Residential areas are typically defined so as to be protected from the encroachment of non-residential uses that are not conducive to a residential environment. Consideration is given to the proper functional relationship and arrangement of each residential district. The L-1, R-1, R-2, R-3, and R-4 residential districts are intended to protect the integrity, value, and enjoyment of use of the dwellings in each district, while also providing a variety of housing types throughout the county.

2.4.3 Non-residential districts

Conventional non-residential districts are intended to provide for commercial and industrial uses to provide for a balanced and prosperous community. The B-1, B-2, B-3, B-4, B-5, I-1, I-2 and AED non-residential, non-agricultural districts are intended to broaden the tax base and further support community services, while creating jobs and providing goods and services to the residents and businesses of White County.

2.4.4 Overlay districts

An overlay district is a semi-transparent zoning district that is placed on top of one or more underlying existing zoning districts. The presence of the overlay district means that there are additional standards and restrictions with which development within that area must comply. Landowners within an overlay district must first comply with the provisions of the underlying, base zoning district and then the provisions of the overlay district. Overlay districts are typically used to: (1) create a location for premier or targeted businesses; (2) unify streetscape and architecture without monotony; (3) control traffic problems and/or signage; (4) require open space and landscaping. In any instance, the requirements of an overlay district may be more or less restrictive than the underlying base zoning district. In addition to bulk use standards, overlay districts typically govern the following types of standards and regulations: lighting, signage, access points on major roads, uses, accessory buildings, architectural design, landscaping, storage and loading areas, and parking.

2.5 STANDARDS AND REGULATIONS BY DISTRICT

Included on the following pages are descriptions of the intent of each zoning district governed by this Ordinance and any additional regulations and/or standards that apply to parcels within a given district.

2.5.1 A-1 General Agricultural District

A. Purpose and Intent

White County is one of the largest crop producers across the State of Indiana. The purpose of the A-1 General Agricultural District is to provide for and protect substantial areas of contiguous land where little or no urbanization has occurred or is planned to occur. It is the intent of this district to limit residential uses, thereby discouraging the development of residential subdivisions, in order to provide for adequate land which is necessary to protect the farming industry and overall economy of White County.

B. Additional standards and regulations

All applicants, developers, landowners who develop any use in any district which abuts an A-1 district shall be required to enter into an agreement acknowledging the County's Right to Farm Ordinance provisions.

For subdivision of a parcel into new parcels, lots or tracts refer to the White County Subdivision Control Ordinance.

For CFO or CAFO operations see Chapter 3 for additional developmental and use standards.

2.5.2 **A-2 Agricultural Industry District**

A. Purpose and Intent

The purpose of the A-2 Agricultural Industry District is to provide adequate land for more intense agricultural uses and agricultural related industries. This includes, but is not limited to: confined feeding operations, digesters and livestock auction yards. Residential subdivisions are prohibited in order to prevent conflicts with the otherwise intense uses intended for an A-2 District. Physical separation between an A-2 District and other residential and non-residential districts may also be necessary in order to further reduce conflicts between otherwise incompatible land uses, to the extent that all future A-2 Districts will require a rezoning to provide for an additional layer of review for the purposes of adequately addressing any issues specific to a proposed use.

B. Setbacks

For the purpose of satisfying the setback requirements of this Section, any building or structure used in conjunction with an existing Digester or CFO/CAFO, shall be allowed to expand or reconstruct facilities, their zoning district boundaries and/or operations as long as such expansion or reconstruction occurs no closer to the setback standards than those physically in place as of July 1, 2016 or as provided below, whichever are least restrictive.

The setback requirements established by this Section shall not be applied to any new residential construction or rezoning occurring after July 1, 2016, excluding reconstruction on a site with existing residential use.

1. Those structures used in confined feeding operations, auction yards and digester operations shall have a setback of one thousand three hundred twenty (1,320) feet from any other non-agricultural district, residence or business, unless located on the same property.
2. The District cannot be located within one (1) mile of an incorporated municipality or the unincorporated town areas of Idaville and Buffalo utilizing such boundary lines as provided for on the White County Official Zoning Map.
3. The District cannot be located within one and one-half (1 ½) miles from any Lake Shafer, Big Monon, Tippecanoe River or Lake Freeman shoreline boundary as provided for on the White County Official Zoning Map.
4. The District cannot be located within one thousand seven hundred sixty (1,760) feet from the property line of any parcel of land legally platted within a recorded subdivision and which subdivision has at least six (6) lots developed with residential dwelling units.

C. All A-2 District uses must provide documentation demonstrating compliance with all Local, State and Federal laws, codes and ordinances including valid permits in cases where permits are required prior to issuance of any Improvement Location Permits or Building Permits.

D. All applicants, developers, landowners who develop any use in this district or within one (1) mile of this district shall be required to enter into an agreement acknowledging the County's Right to Farm Ordinance provisions.

E. Major drainage system and water wells shall be in compliance with IDEM standards.

F. Setbacks shall not apply to fences for areas where animals graze.

G. For subdivision of parcels into new parcels, lots or tracts refer to the White County Subdivision Control Ordinance.

H. Right to Waiver:

The setback standard for "distance to a residence", provided for in Subsection 3.17.1 & 2.5.2 B. 1 of this Ordinance, is subject to waiver under the guidelines provided for in this Section. A parcel with a waiver exempts the residence which is located upon that parcel from consideration in determining compliance to the standards established by Subsections 3.17.1 & 2.5.2 B. 1 of this Ordinance.

For the purposes of this section, a "Subject Parcel" is defined as:

- 1) A parcel of land designated with an A-2 District zoning assignment;
- 2) A parcel of land for which a rezone petition to change a parcel of land to an A-2 District zoning assignment has been officially filed with the Area Plan Department; or,
- 3) A parcel of land with an A-1 District zoning assignment and upon which a confined feeding operation has been grandfathered.

A) The owner of a Subject Parcel may request a waiver for a parcel of land with a unique Parcel Identification Number; hereafter referred to as a "PIN Parcel", under the following conditions:

1. The owner of the PIN Parcel is an individual or entity with legal connections to the Subject Parcel and/or its land use;
2. The PIN Parcel must be utilized, at least in part, for residency purposes;
3. The PIN Parcel must be designated with an RR, A-1 or A-2 zoning district;
4. Only one (1) PIN Parcel can be granted waiver rights in association with any given Subject Parcel;
5. The Waiver request must be submitted to the Area Plan Department on a form approved by the Staff; and,
6. Upon approval of the request by the Staff, the form must be recorded in the White County Recorder's Office by a party affiliated with the request and a copy of the recorded document provided to the Staff, all expenses of which are the responsibility of the party requesting the waiver.

A Waiver runs with the land until such time as an owner of the affected property revokes the Waiver via written notification to the Area Plan Department. Revocation of the Waiver does not affect a District assignment or Confined Feeding facilities established during the period of time the Waiver was in effect.

2.5.3 **RR Rural Residential District**

A. Purpose and Intent

The purpose of the RR Rural Residential District is to provide areas of land that will accommodate a variety of less intensive agricultural uses as well as some very low-density single-family residential subdivisions. Subdivisions are preferred over single lot splits to encourage more compact and contiguous development which in turn avoids the stripping out of county roads. While this district is not intended to be located within incorporated municipalities, the residential subdivisions of a RR District should be located near public utilities whenever possible.

B. Additional standards and regulations

As part of the subdivision process, all applicants, developers, landowners who develop a subdivision in this district shall be required to enter into an agreement acknowledging the County's Right to Farm Ordinance Provisions. A notation shall also be placed in covenant documents and on the subdivision plat.

Any subdivisions that have more than 25 lots within a subdivision shall provide at least twenty-five (25) percent open space. Refer to the White County Subdivision Control Ordinance.

Entrance for subdivisions shall be off a county or municipal road.

All driveways for residences located in subdivision shall be located off the subdivision road. No driveways shall be located off a county or municipal road.

For subdivision of parcels to create new parcels, lots or tracts refer to the White County Subdivision Control Ordinance.

2.5.4 **L-1 Lake District**

The purpose of the L-1 Lake District is to provide adequate land for residential development adjacent to lakes, rivers or other bodies of water in White County. The regulations of an L-1 District are intended to accommodate lakefront property while maintaining the scenic beauty and character of the surrounding area. They are further intended to protect properties along the water's edge from erosion. There are no additional standards or regulations for properties located with L-1 Lake District prescribed by this Ordinance.

2.5.5 **R-1 Single-Family Residential District**

The purpose of the R-1 Single-Family Residential District is to provide adequate land for low-density single-family residential uses. It is anticipated that because of the relatively smaller lot sizes all R-1 districts will be located within an incorporated municipality near existing residential areas. Uses within an R-1 District should primarily consist of relatively low-density single-family dwellings, accessory structures, and related recreational, religious, and educational facilities. Any subdivisions that have more than 25 lots within a subdivision shall provide at least twenty-five (25) percent open space. Refer to the White County Subdivision Control Ordinance.

2.5.6 **R-2 Single and Two-Family Residential District**

The purpose of the R-2 Single and Two-Family Residential District is to provide adequate land for single-family and two-family residential uses. It is anticipated that, like the R-1 District, the majority of R-2 Districts will be located within an incorporated municipality near existing residential areas. Uses within an R-2 District should primarily consist of relatively small to medium sized single-family and two-family dwellings, accessory structures, and related recreational, religious, and educational facilities. Any subdivisions that have more than 25 lots within a subdivision shall provide at least twenty-five (25) percent open space. Refer to the White County Subdivision Control Ordinance.

2.5.7 **R-3 Multi-Family Residential District**

The purpose of the R-3 Multi-Family Residential District is to provide adequate land for high-density residential uses. It is anticipated that because of the relatively higher residential density and the requirement that all multi-family development be connected to public sewer and water utilities, all R-3 Districts will be located within an incorporated municipality. Uses within an R-3 District should primarily consist of multi-family dwellings, which may include apartments, condominiums and townhouses. There are no additional standards or regulations for properties located with R-3 Multi-family Residential districts governed by this Ordinance.

2.5.8 **R-4 Mobile & Manufactured Home Park Residential District**

The purpose of the R-4 Mobile Home Park District is to provide adequate land for mobile and manufactured homes. It is anticipated that all mobile and manufactured residential development will be located within a coordinated park/subdivision development. Uses within an R-4 District should consist of those uses which are typically associated with a mobile or manufactured home park/subdivision.

2.5.9 **B-1 Neighborhood Business District**

The purpose of the B-1 Neighborhood Business District is to provide adequate land which will accommodate a mix of uses. It is anticipated that all B-1 Districts will be located in downtown areas of the incorporated municipalities or in commercial areas where a parcel of limited size exist and which is deserving of relieved standards. Uses within a B-1 District are typically centered on personal service needs, local retail needs and institutional/governmental uses, although each downtown is encouraged to identify its niche market. Residential uses located above ground floor uses are also appropriate for a B-1 District. There are no additional standards or regulations for properties located within B-1 Neighborhood Business districts governed by this Ordinance.

2.5.10 **B-2 General Business District**

The purpose of the B-2 General Business District is to provide adequate land for medium to larger scale business and service establishments that provide for the everyday shopping needs of the community. It is anticipated that B-2 Districts will be located near a B-1 District, or at the intersections of primary thoroughfares within or near a municipality. Uses within a B-2 District will vary; however, such uses typically serve the local population as opposed to travelers and motorists.

There are no additional standards or regulations for properties located with B-2 General Business districts governed by this Ordinance.

2.5.11 **B-3 Highway Business District**

The purpose of the B-3 Highway Business District is to provide adequate land for regional business and service establishments which are otherwise intended to serve the travelers and motorists as well as local residents. It is anticipated that all B-3 Districts will be located around an interstate highway interchange or state highway intersection. There are no additional standards or regulations for properties located with B-3 Highway Business districts governed by this Ordinance.

2.5.12 **B-4 General Business Dense Development District**

The purpose of the B-4 General Business Dense Development District is to provide adequate land which will accommodate a mix of uses. It is anticipated that all B-4 Districts will be located in downtown areas of the incorporated municipalities or nearby to the downtown areas but which are dense development areas with characteristics of excessively small lot sizes combined with extreme lot coverage and with one or more shared walls with neighboring developments. Uses within a B-4 District are of a mixed-use nature to provide diversity of use to the downtown areas. It would be expected to have residential and commercial business uses of a wide variety located within a B-4 District. There are no additional standards or regulations for properties located within B-4 General Business Dense Development Districts governed by this Ordinance.

2.5.13 **B-5 Transitional Business District**

The purpose of the B-5 Transitional Business district is to provide for a commercial district which limits site uses to relatively low-level commercial activities. This district is designed to serve as a transition district between residential and more intrusive or high intensity commercial or industrial districts thus providing a buffer to residences and residential neighborhoods. B-5 district uses would be restricted to those types of commercial activities which operate in a manner which is less of a nuisance to the uses allowed in a residential district thereby keeping more incompatible commercial and industrial uses from directly abutting residential areas. Considerations which should be taken into account for uses which should not be targeted for this district designation are those which have late night hours, commonly generate high noise levels, are geared toward adult-only venues, commonly have outside storage or outdoor operational activities, involve use of hazard chemicals, generate hazardous waste or have other aspects which are disruptive to or incompatible with a residential, neighborhood character. These districts should be restricted to locations where some uses of the general business district assignment could have a significant, negative impact on abutting or nearby residential properties.

2.5.14 **I-1 Light Industrial District**

The purpose of the I-1 Light Industrial District is to provide adequate land for less intensive industrial uses. It is anticipated that I-1 Districts will be located so as not to impede residential development. Uses within an I-1 District may include warehousing, office parks, bio-technology research and light manufacturing processes. The processing or manufacturing of materials or products from extracted or raw materials is

strongly discouraged. To the extent possible, uses within an I-1 District should not be noxious or injurious to the surrounding areas by reason of emission or creation of noise, vibrations, smoke, dust or other particulate matter, toxic or noxious materials, odors, fire, explosive hazard, glare or heat. There are no additional standards or regulations for properties located with I-1 Light Industrial districts governed by this Ordinance.

2.5.15 **I-2 Heavy Industrial District**

The purpose of the I-2 Heavy Industrial District is to provide adequate land for more intense industrial uses. This includes, but is not limited to: the basic processing and manufacturing of materials or products predominately from extracted or raw materials; or are engaged in the storage or manufacturing processes using flammable or explosive materials, or storage or manufacturing processes that potentially involve hazardous or commonly recognized offensive conditions. It is anticipated that all I-2 Districts will be located so as to be buffered from any adjacent district. There are no additional standards or regulations for properties located with I-2 Heavy Industrial districts governed by this Ordinance.

2.5.16 **I-3 Industrial Park District**

The purpose of the I-3 Industrial Park district is to provide standards for the Industrial Park properties identified as part of the planned Mid-America Commerce Park area, including current and potential future areas.

A. The intent of the I-3 District is to provide for an industrial area with standards which accomplish the following:

1. Avoidance of pitfalls typically associated with interstate interchange development;
2. Assure development meets aesthetic and design quality objectives;
3. Encourage economic development and job growth as required to support advanced manufacturing and logistics industry requirements;
4. Establish a thriving business gateway to the greater White County community;
5. Protect the natural amenities of the Mid-America Commerce Park;
6. Promote well planned development of the I-3 District area;
7. Encourage and protect the capital investment of those companies desiring to locate and create jobs within White County;
8. Create a cohesive campus-like business park; and,
9. Establish resolution procedures for regulation conflict.

2.5.17 **AED Amusement and Entertainment District**

The purpose of the Amusement and Entertainment District (AED) is to provide adequate land which will accommodate a mix of intensive recreation, resort and entertainment uses in one district with the intent of preserving the tourist benefit of the AED District. The overall size, hours of operation, the wide range of uses and associated activities has the potential to negatively impact surrounding properties.

The AED District accommodates these activities and provides flexibility in the expansion and continued use of the land.

A. Location

The district shall have frontage on and access to a roadway with adequate capacity to handle any increase projected in traffic flow, both increased levels and type of traffic expected.

B. Site enclosures

Any main amusement park or primary use area shall be enclosed by a minimum of six (6) foot woven-wire or solid fence. Off-street parking areas need not be included within the fenced in area.

C. Signs

All signage within an Amusement and Entertainment District are exempt from the signage regulations of this Ordinance.

D. Lighting

All lighting shall be reflected away from adjacent districts. Downward lighting shall be used on all lights used for signs, pathway and general lighting.

E. Federal and State Approval

Uses in this district shall comply with any and all federal and state regulations.

2.5.18 Overlay Districts

As prescribed in Chapter 6, Overlay Districts, of this Ordinance.

CHAPTER 3 SPECIFIC USE REQUIREMENTS AND PERFORMANCE STANDARDS

3.0 LOT REQUIREMENTS

The following specific lot requirements shall apply in all zoning districts governed by this Ordinance.

3.0.1 Lots

The following requirements shall apply to all lots within the jurisdiction of this Ordinance.

3.0.2 Number of principal buildings per lot

In any district, no more than one (1) principal building and its customary accessory structures shall be located on a single lot of record, with the following exceptions:

- A) Multi-family residential projects where the buildings are designed and platted as a single operating unit under single ownership and control.
- B) Commercial, agricultural or industrial uses commonly configured with multiple buildings having the same purpose. This includes, but is not limited to, self-service storage facilities, boat storage operations, other storage use sites, combined industrial operations and confined feeding operations.

C) Subordinate Dwelling Unit

In addition to the subordinate dwelling unit regulations found in Chapter 14, Appendix A and Appendix B of the White County Indiana Zoning Control Ordinance, the following standards, regulations and requirements must be met but which may be subject to Variance approval by the Area Board of Zoning Appeals.

- 1) Lot coverage, as defined in Chapter 14, cannot exceed sixty percent (60%);
- 2) Lot size must be a minimum of twelve thousand (12,000) square feet;
- 3) Each dwelling unit must have a unique and separate ingress/egress drive to the street/road rights-of-way;
- 4) Each dwelling unit must have its own well or be connected to a public water system; and,
- 5) Each unit must have its own septic or be connected to a public waste water line; public waste water entity includes Twin Lakes Regional Sewer District.

The following prohibitions apply to properties which include both a principal and subordinate dwelling unit:

- 1) No property which includes a principal and subordinate dwelling unit may also include a duplex, apartment or accessory apartment; and,
- 2) Neither the principal or subordinate dwelling unit may be used for short term rental purposes.

In these cases, all subject buildings must meet the principal structure developmental standards for the applicable zoning district and be utilized for the same use category.

3.0.3 Division of lots

No lot shall hereafter be divided into two (2) or more lots for the purpose of transfer of ownership, unless the division conforms to the applicable regulations of the White County Zoning and Subdivision Control Ordinances.

3.0.4 Corner lots

A lot located at the corner of two (2) or more streets shall treat each yard that faces a street as a front yard. In which case, each yard facing a street shall be subject to the applicable front yard setbacks and all other applicable requirements thereof. Therefore, the side and rear yards may be transitional and must be declared at the time of application.

3.0.5 Street frontage and access

Every lot must have frontage on a public street and must be provided with traffic access points for adequate ingress and egress to and from such public street. All lots having one hundred (100) feet or less of frontage shall have a maximum of one (1) ingress and egress point. A private road may be used in lieu of public streets for frontage provided the layout and design of such road is approved by the Area Plan Commission.

3.0.6 Lot area exclusions

Any portion of any lot located within a 100-year floodplain, a floodway, wetland, lake, pond, storm water detention area, or an area used for floodplain compensatory storage, may not be counted towards the applicable minimum lot area requirement.

3.0.7 Vision clearance triangle

No building, structure, or improvement, including landscaping, shall be erected, placed, planted or maintained within a Vision Clearance Triangle (see below) so as to interfere with a vision clearance area; the vision clearance area is the area of space within a Vision Clearance Triangle between the heights of two and one half (2 ½) feet and twelve (12) feet above the crown of a street, driveway or alley. With the exception of official warning signs or signals necessary for public safety, a vision clearance triangle shall be established for all streets whether public or private, driveways, railroad crossings and alleys as prescribed in (A) through (D) below.

A. Street/Road Intersection

Unless excluded elsewhere in this Ordinance, a property abutting a street/road intersection is subject to a vision clearance triangle. The vision clearance triangle is triangular shaped with two sides being formed by the street right-of-way lines and the third side being the line connecting points twenty-five (25) feet from the intersection of such street right-of-way lines, or in the case of a round or cut property corner, from the intersection of the street right-of-way lines extended.

See Figure 3.1 (a) & (b) for examples

Figure 3.1 (a) & (b) – Vision Clearance Triangle; Street & Road Intersections

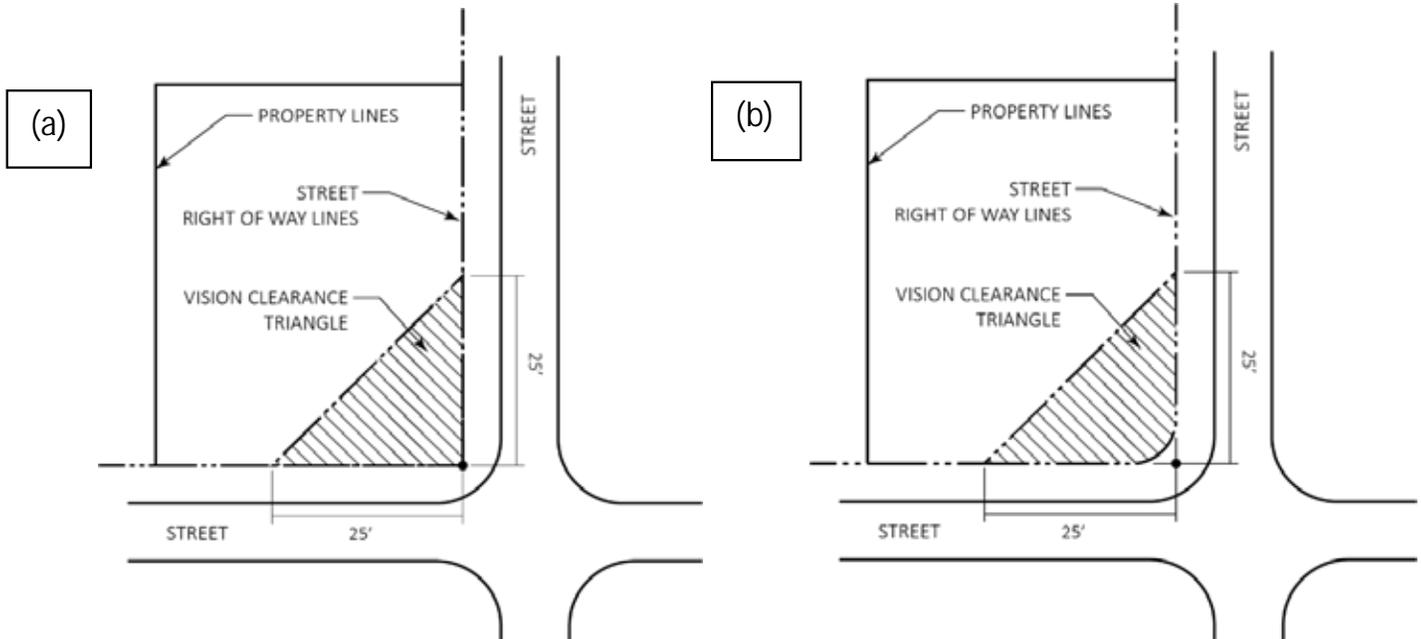

B. Land adjacent to an at-grade railroad crossing

Unless excluded elsewhere in this Ordinance, land adjacent to an at-grade railroad crossing is subject to a vision clearance triangle. The vision clearance triangle is triangular shaped beginning at the point of intersection of the street/road right-of-way and the railroad right-of-way, then extending along each right-of-way line a distance of twenty-five (25) feet to two end points. The end points are then connected to create a third line thus establishing the vision clearance triangle.

See Figure 3.2 for an example.

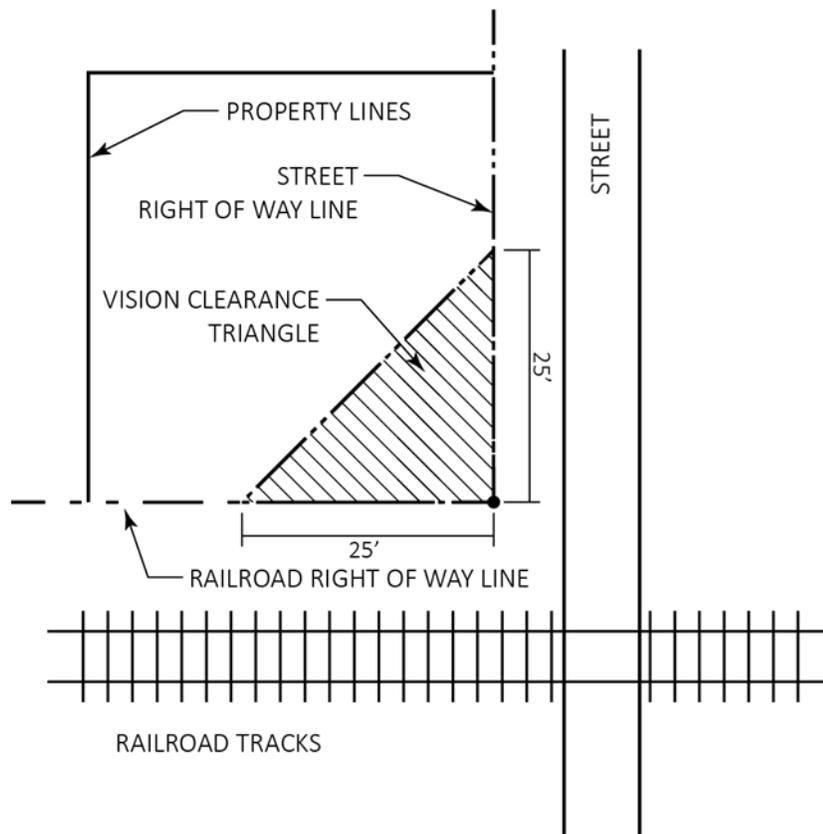
Figure 3.2 – Vision Clearance Triangle; Adjacent to A Railroad Crossing

C. Street/Road & Alley Intersections

Unless excluded elsewhere in this Ordinance, all street/road and alley intersections are subject to a vision clearance triangle. The vision clearance triangle is triangular shaped, one side of which is formed by the street right-of-way line, the second side of which is formed by the alley right-of-way line. The third side is formed by connecting the two points twenty-five (25) feet from the intersection of the two sides formed by the street/road and alley right-of-way sides.

See Figure 3.3 for an example.

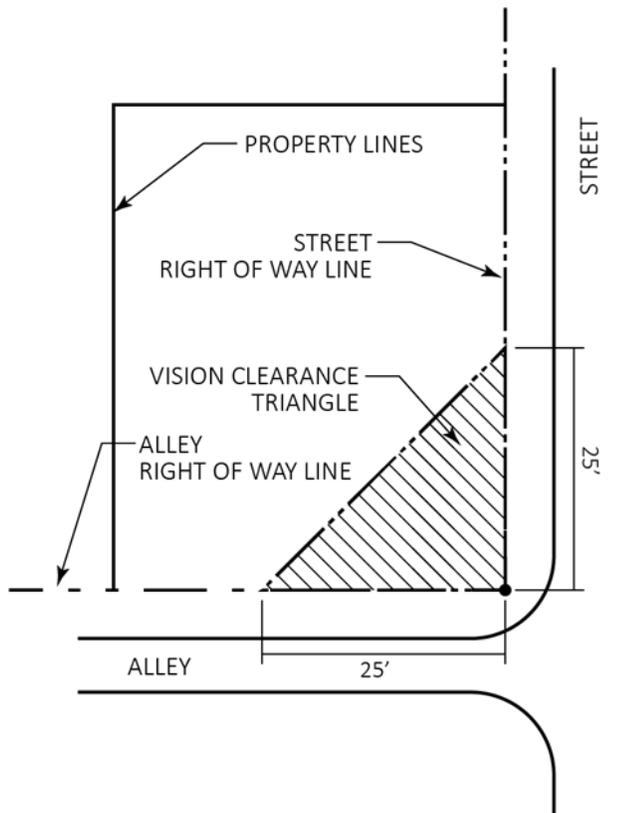
Figure 3.3 – Vision Clearance Triangle; Street or Road & Alley Intersection**D. Driveway**

Unless excluded elsewhere in this Ordinance, each driveway shall maintain a vision clearance triangle. The vision clearance triangle is triangular shaped, one side of which is formed by the edge line of the driveway, the second side of which is formed by the street/road right-of-way line. The third side is formed by connecting the two points twenty-five (25) feet from the intersection of the two sides formed by the street/road right-of-way line and the edge line of the driveway. The vision clearance triangle requirement applies to both edge lines of the driveway. In the case of vision clearance triangles for driveways, the vision clearance triangle stops at the subject property's property line.

See Figure 3.4 for an example.

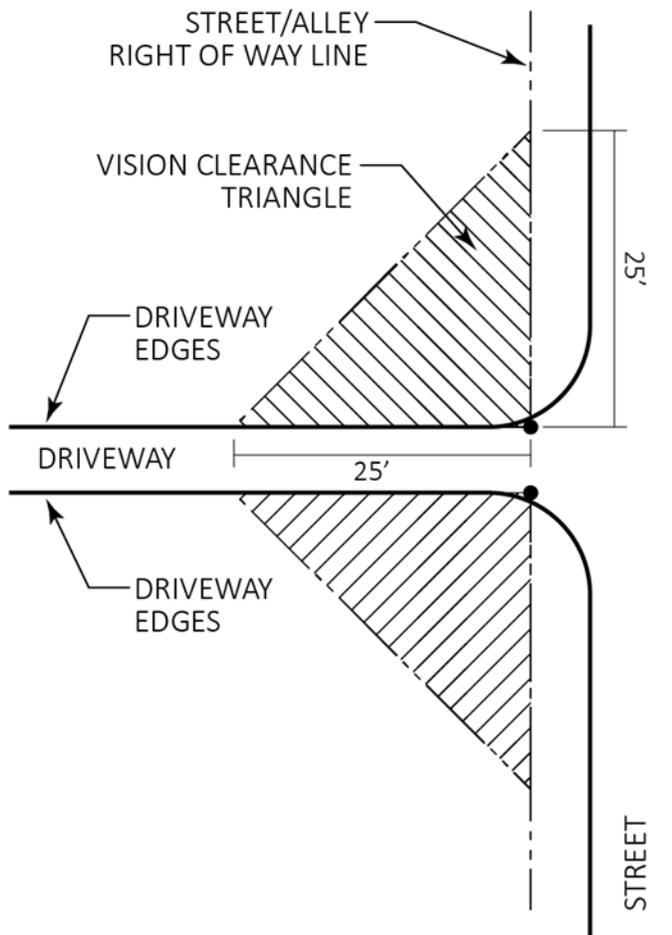
Figure 3.4 – Vision Clearance Triangle; Driveway

3.1 HOME OCCUPATIONS

All home occupations must satisfy the requirements of this Chapter in addition to any standards or regulations found elsewhere in this Ordinance.

3.1.1 Purpose and scope

It is the intent of this Section to regulate all home occupation uses. The standards of this Section are intended to ensure compatibility of home occupations with the residential character of any neighborhood establishing them as a clear secondary or incidental use to the permitted residential use of the principal structure. For the purposes of administering and enforcing this Section, a home occupation exists if an owner, lessee, or other person legally residing in a residential dwelling is also conducting a legitimate business from the home or property. Such home occupation shall be subject to the conditions and requirements of this Section.

3.1.2 Required conditions

In general, home occupations are permitted accessory uses in any residential or A-1 district, provided that said home occupation complies with the following:

- A. Such occupation shall be conducted solely by occupants residing at the residence. Upon approval of the Area Board of Zoning Appeals, a business which has employees, other than the occupants, where the primary activities are conducted at other locations (such as a building contractor) and where employees are on-site for incidental purposes only (such as being scheduled for their assignment location or to receive work orders) may be treated as a home occupation if the Area Board of Zoning Appeals determines all other home occupation criteria will be met and that the on-site activities related to the employees will not result in a detrimental effect or nuisance to the neighborhood.
- B. The use of the dwelling unit for the home occupation shall clearly be incidental and subordinate to the principal use of the structure as a residential dwelling, to the extent that no more than twenty-five (25) percent of the gross floor area of the dwelling unit, including any accessory buildings, may be used for the conduct of the home occupation.
- C. Home occupations may be located in either the dwelling unit or accessory building, but not both.
- D. No home occupation use shall require internal or external alterations or involve construction features or the use of electrical or mechanical equipment that would change the fire rating of the residential dwelling or accessory structure, or the fire district in which the structure is located;
- E. There shall be no outdoor storage of any kind which is related to the home occupation;
- F. Only one (1) nameplate sign and one (1) yard sign shall be allowed regardless of the number of streets that the property faces. The nameplate sign may display the name of the occupant and/or the name of the home occupation. The nameplate sign may be attached flat to the principal structure or placed so as to be visible from the street through a window. The nameplate sign shall be no greater than three (3) square feet in area. The yard sign shall have a face no greater than six (6) square feet and not taller than five (5) feet in overall height. No such sign shall be illuminated.
- G. No home occupation shall generate more traffic or parking capacity requirements or otherwise cause the local traffic volume to increase, than would normally be expected or appropriate in a residential neighborhood wherein no home occupation exists. All excess parking needs generated by the home occupation beyond what's readily available, shall be met by the off-street parking requirements as specified in this Ordinance, provided that in no instance shall parking for a home occupation be allowed to occur in a required front yard setback.
- H. No home occupation use shall create noise, dust, vibration, smell, smoke, glare, electrical interference, fire hazard, or any other hazard or nuisance to any greater or more frequent extent than is expected or appropriate in a residential neighborhood wherein no home occupation exists. In the case of electrical interference, no

equipment or process shall be used which creates visual or audible interference in any radio or television receivers or causes fluctuations in the line voltage off-site.

I. No home occupation shall involve the use of commercial delivery vehicles for the transport of materials to or from the premises, with the exception of delivery vehicles which are typically associated with residential home delivery, such as postal or parcel vehicles.

J. No home occupation shall cause a nuisance to the residential neighborhood in which it exists.

3.1.3 Uses that are prohibited as home occupations

The following uses by the nature of the investment or operation have a pronounced tendency once started to rapidly increase beyond the required provisions of a home occupation and thereby impair the use and value of a residentially zoned area.

Therefore, the following uses shall not be permitted as home occupations:

Auto/vehicle repairs, minor or major;

Gift shops;

Dance studio;

Dental clinic;

Freight, trucking, or shipping;

Unlicensed Massage Parlors (no Indiana State License);

Medical clinic;

Painting of vehicles, trailers, boats, etc.;

Retail photo developing;

Private schools with organized classes;

Restaurants, eating or drinking establishments;

Tattoo Parlors;

Tooling, welding or machinery shops;

Tool or equipment rental;

Veterinary clinic, kennel, or stables; or

Any other uses not meeting the conditions of this Section as determined by the Executive Director.

3.1.4 Examples of uses that frequently qualify as home occupations

Accountants;

Artists and sculptors;

Authors and composers;

Barber shop;

Beauty shop;

Dressmakers, seamstresses and tailors;

Child care limited to no more than five (5) children.

Individual tutoring;

Individual music, dancing, or singing lessons;

Office facility of a member of the clergy

Office facility of a sales person, sales representative, or manufacturer's representative provided that no exchange of retail or wholesale merchandise is made on or adjacent to the premises;

Office facility of a professional such as a plumber, electrician, appraiser, architect, engineer, lawyer, insurance agent, land surveyor, real estate agent, consultant, etc.;

Traditional full or part-time sales occupations;

Appliance, television, radio, lawn mower or bicycle repair;

Photography studio, one client at a time;

Upholstering;

Massage Therapy (Indiana State Licensed); or

Any other use that complies with all of the restrictions and conditions of this Section as determined by the Executive Director.

3.1.5 Professional offices – special restrictions

A physician, dentist, lawyer, member of the clergy, engineer, insurance agent, real estate agent, consultant, or other professional person may use his/her residence for office work, consultation, emergency treatment, or performance of religious rites, but not for the general practice of his profession and not for the installation or use of any mechanical or electrical equipment customarily incidental to the practice of any such profession.

3.1.6 Child care homes - special restrictions

The restrictions of Subsection 3.1.6 apply to Child Care Homes whether operating as a home occupation or out of a residential structure not used as a dwelling.

1. In any residential district where a Child Care Home operates, each parcel is restricted to one (1) Child Care Home license.
2. A Child Care Home and a Child Care House may not operate on the same parcel.

3. No two residential district parcels, upon which facilities are used, or are planned to be used, to operate a Child Care Home, may be located any closer than five hundred (500) feet, as measured in a straight line, without regard to intervening structures or objects, between the closest parcel lines of each parcel.
4. All residential district parcels used or intended to be used for a Child Care Home must install a 6' foot, opaque privacy fence along any property line abutting a residential district which is used for dwelling purposes.
5. A Child Care Home, as defined in Chapter 14, Definitions, when operating on the same parcel upon which a dwelling is located, shall meet all requirements of a home occupation as set forth in this Chapter with the exception of those standards which are inconsistent with state licensure requirements as contained in Indiana Code 12-7-2-33.7 and 12-7-2-33.8 as amended.
6. A Child Care Home shall meet all requirements for licensure under state law, and shall be operated in such a manner as to maintain the residential nature of the neighborhood in which it is operated.

All Child Care Homes legally operating as of January 1, 2016 and not in compliance with the standards required of this Ordinance, will be provided legal non-conforming status until such time as one of the disqualifying events listed below occurs.

Disqualifying Events:

- a. Child Care Home activities cease for a period of six (6) months or more;
- b. A Child Care Home has its license:
 - 1) revoked by the appropriate State agency;
 - 2) lapse;
 - 3) re-licensed under a person or entity name other than the name under which the license operated at the time of adoption of this Ordinance Amendment;
- c. Title of the property is transferred to another party.

Upon occurrence of one of the "Disqualifying Events", a Child Care Home shall cease operation or be brought into compliance with current Ordinance requirements. Failure to execute one of the actions above will be considered a civil zoning violation and subject the site to enforcement proceedings as provided for by Ordinance.

The Child Care Home may have such employees as required by state law or regulation, and may operate in that part of the residence necessary to meet licensure requirements.

The Child Care Home shall operate in such a fashion as not to cause abnormally unsafe or disruptive vehicular traffic congestion in the day care home neighborhood. On-street parking of employees shall be limited to two (2) parked vehicles during the child care operating hours but only for locations where the parcel of the Child Care Home abuts a street where on-street parking is allowed and where the parking allowance is not in conflict with any other standard or requirement of this Ordinance.

3.2 **BED AND BREAKFAST ESTABLISHMENTS**

In addition to all applicable requirements of the Indiana Building Code, bed and breakfast establishments, where allowed, shall adhere to the following requirements.

3.2.1 **Location**

Bed and breakfast establishments shall only be located within a single-family home occupied by the owner or a live-in manager whom is on the premises when occupied by guests.

3.2.2 **Health regulations**

Bed and breakfast establishments shall comply with all applicable local, county and state fire and health regulations.

3.2.3 **Ancillary commercial use prohibited**

No ancillary commercial use shall be operated in connection with any bed and breakfast establishment.

3.2.4 **Classification of use**

The operation of a bed and breakfast establishment shall not be considered or classified as a home occupation.

3.2.5 **Number of rooms permitted**

The number of rooms permitted in any bed and breakfast establishments shall be as prescribed by the Indiana Building Code.

3.2.6 **Length of stay**

No guest of a bed and breakfast establishment may stay longer than thirty (30) consecutive days.

3.2.7 **Operator requirement**

The operator of the establishment shall reside within the bed and breakfast establishment or within some other approved dwelling located on premises adjacent to said establishment.

3.2.8 **Parking requirement**

Parking for any bed and breakfast establishment shall be in accordance with Chapter 8, Parking and Loading Standards.

3.3 **MANUFACTURED AND MOBILE HOMES**

Any manufactured home or mobile home permitted within the jurisdiction of the White County Plan Commission shall have been constructed on or after January 1, 1981. These general manufactured home and mobile home requirements shall apply to all

zoning districts where a manufactured home or mobile home is permitted under Appendix A, Official Schedule of Uses, and to manufactured homes and mobile homes permitted under section 4.5.8 of this ordinance. The establishment, location, and use of all manufactured homes and mobile homes shall meet the installation instructions of the manufacturer, and all standards set forth in Appendix B and minimum parking requirements for single-family dwellings. They shall also meet the requirements in Sections 3.3.1 or 3.3.2, whichever shall apply.

3.3.1 Type I Manufactured Homes

Living area

All Type I Manufactured Homes shall have, in a double section or larger, multi-section unit living area no less than the minimum required for the district in which it is intended to be located.

Foundation

All Type I Manufactured Homes shall be placed on a permanent foundation which is to include an exterior perimeter block retaining wall that is consistent with those for, or planned for, other homes in the area. They shall be installed consistent with the manufacturer's installation instructions and comply with all applicable provisions of the local Building Code.

Anchoring

All Type I Manufactured Homes shall be anchored to the ground in accordance with the manufactured home's installation requirements and the local Building Code.

Travel equipment

All travel equipment; including wheels, axles, and hitch mechanisms shall be removed upon placement of any Type I Manufactured Home.

Utilities

All Type I Manufactured Homes shall meet utility connection requirements in accordance with the manufactured home's installation requirements and the local Building Code.

Siding material

All Type I Manufactured Homes shall have siding material of a type similar to, or otherwise compatible with that which is found on other dwellings in, or planned for, the area.

Roofing material

All Type I Manufactured Homes shall have roofing material of a type similar, or otherwise compatible with, that which is found on other dwellings in, or planned for, the area.

3.3.2 Type II Manufactured Homes

Living area

All Type II Manufactured Homes shall have a minimum of eight hundred and fifty (850) square feet of living area in a single, double, or multi-section unit, including those with a pullout or tag-along unit.

Foundation

All Type II Manufactured Homes located in any R-1 (single family residential) or R-2 (single and two-family residential) zoning district shall be placed on a permanent foundation which is to include an exterior perimeter block retaining wall that is consistent with those for, or planned for, other homes in the area. They shall be installed consistent with the manufacturer's installation instructions and comply with all applicable provisions of the local Building Code.

Anchoring

All Type II Manufactured Homes shall be anchored to the ground in accordance with the manufactured home's installation requirements and the local Building Code.

Travel equipment

All travel equipment; including wheels, axles, and hitch mechanisms shall be removed upon placement of any Type II Manufactured Home.

Utilities

All Type II Manufactured Homes shall meet utility connection requirements in accordance with the manufactured home's installation requirements and the local Building Code.

3.4 **TEMPORARY MANUFACTURED OR MOBILE HOMES**

The temporary use of a Type II manufactured home or a mobile home shall be permitted as prescribed by Appendix A, Official Schedule of Uses, provided that the temporary use complies with this Section.

3.4.1 **Temporary residence during home construction**

A Type II manufactured home or mobile home may be used as a temporary residence during the construction or renovation of a single-family dwelling on the lot for which a permit to construct or renovate said single-family dwelling has been obtained.

Permits required

A Special Use Permit and an Improvement Location Permit for a temporary structure shall be obtained prior to the installation of the manufactured or mobile home.

Expiration

Both permits shall expire with the approval of the Occupancy Permit for the permanent residence, or two (2) years from the issuance of the temporary Improvement Location Permit, whichever comes first.

Location and access

The temporary residence shall conform to the setback requirements for the district in which it is located. In addition, the temporary residence shall be accessible by the same driveway as the permanent residence.

Removal plan

At the time of application, the applicant shall provide a detailed plan for the subsequent removal of the temporary residence. The removal plan shall include the intended location of disposal or relocation, as well as an estimated cost for disposing or relocating said residence.

3.4.2 Temporary residence for a care-giver/dependent relative

A Type II manufactured home or mobile home may be used as a temporary residence for either an individual providing care to a dependent relative or a dependent relative in need of continuous, on-site care.

Permit required

A Special Use Permit and an Improvement Location Permit for a temporary structure shall be obtained prior to the installation of the manufactured or mobile home.

Expiration

Both permits shall expire at the time the dependent relative no longer requires continuous, on-site care.

Location and access

The temporary residence shall be located on the same lot as the permanent residence of the other individual in the dependent/care-giver circumstance. The temporary residence shall conform to the setback requirements for the district in which it is located. In addition, the temporary residence shall be accessible by the same driveway as the permanent residence.

Removal plan

At the time of application, the applicant shall provide a detailed plan for the subsequent removal of the temporary residence. The removal plan shall include the intended location of disposal or relocation, as well as an estimated cost for disposing or relocating said residence.

3.5 MOBILE HOME PARKS AND SUBDIVISIONS

It shall be unlawful for a person to keep, store, or maintain any mobile home park or subdivision within the County's jurisdiction that does not comply with the requirements of this Ordinance. All mobile home parks and subdivisions shall comply with this Section.

3.5.1 Entrances and interior roads

All interior streets shall either be dedicated to the public or be private interior drives. All interior streets, regardless of ownership, shall meet the design and construction standards of the White County Subdivision Control Ordinance. If private streets are used, street easements shall substitute for the interior street right-of-way.

3.5.2 Compliance verification

Prior to the issuance of an Improvement Location Permit and prior to the construction of the park or subdivision, the following shall be submitted to the Executive Director.

Access

A letter from the appropriate municipal or county engineer of jurisdiction, verifying the approval of the design of access point to public streets.

Sanitary Sewer Service

A letter from the appropriate sewer utility, verifying that adequate sanitary sewer service shall be available to the homes.

Board of Health

A letter from the Indiana State Board of Health verifying that all applicable requirements have been or shall be met.

3.6 CAMPGROUNDS

3.6.1 Minimum Size

The minimum size of a recreational campground shall be five (5) acres. The design, installation, and maintenance shall be as required by the Indiana State Board of Health.

3.6.2 Occupation of tents, cabins and recreational vehicles

Recreational vehicles, cabins and tents are allowed in and may be occupied in any campground. Recreational vehicles shall not be occupied in any location other than an approved mobile home park or AED zoning district except where expressly permitted by this Ordinance.

3.6.3 Campground standards

All campgrounds shall meet the following standards:

Campgrounds shall have direct access to a public street with sufficient frontage thereon for the proper construction of entrances and exits that are designed for the safe movement of recreational vehicles into and out of the campground.

The density of a campground shall not exceed thirty-six (36) recreational vehicle spaces per one (1) acre of gross site area. Gross site area shall include only the land that is designated for camping, exclusive of streets, parking areas, dedicated rights-of-way, and park service facility areas.

Recreational vehicles shall be separated from each other and from other park buildings or structures by a minimum of ten (10) feet.

Where the boundary line of a campground coincides with that of an adjacent residential district where no street or alley separates the two, a buffer shall be required. Said buffer shall be a minimum distance of twenty-five (25) feet in width which contains either a solid fence standing a minimum of eight (8) feet in height, or a solid evergreen hedge.

At least one (1) centrally located recreation area shall be provided in each campground. Said recreational area shall be equal in size to eight percent (8%) of the gross site area, exclusive of streets, parking areas, dedicated rights-of-way, and park service facility areas.

Food stores, restaurants, sporting goods, laundromats, dry cleaners, service stations, and similar convenience and service shops may be permitted in campgrounds containing fifty (50) or more camp sites, provided that such shops and the parking area required by the use shall not occupy more than ten percent (10%) of the total area of the campground.

Management offices and storage, playground and picnic equipment, sanitation and laundry facilities, informational signs and other structures customarily incidental to a campground shall be permitted as accessory uses.

3.7 RECREATIONAL VEHICLE PARK

3.7.1 Minimum size

The minimum size for Recreational Vehicle Parks shall be as follows:

One (1) acre for recreational vehicle parks designed to accommodate twenty (20) or less recreational vehicles spaces at maximum capacity;

Three (3) acres for recreational vehicle parks designed to accommodate between twenty-one (21) and seventy-five (75) recreational vehicle spaces at maximum capacity; and,

Five (5) acres for recreational vehicle parks designed to accommodate greater than seventy-five (75) recreational vehicles spaces at maximum capacity.

The density of any recreational vehicle park shall never exceed thirty-six (36) recreational vehicle spaces per one (1) acre of gross site area. Gross site area shall include only the land that is designated for recreational vehicle parking, exclusive of streets, parking areas, dedicated rights-of-way, and park service facilities.

3.7.2 Entrances and interior roads

Prior to issuance of an Improvement Location Permit and prior to construction of the recreational vehicle park, the following shall be submitted to the Executive Director:

1. Access - A letter from the appropriate municipal or county legislative body verifying the approval of the ingress-egress access design; and,
2. Sewer System - A letter from the appropriate sewer utility, local Health Department or the State Board of Health, whichever applies, verifying the sewer system design meets the requirements for the recreational park design.

3.7.3 Recreational vehicle park standards

All recreational vehicle parks shall meet the following standards:

1. Recreational vehicles shall be separated from each other and from other park buildings or none site required structures, a minimum of 10’;
2. Where the boundary line of a recreational vehicle park coincides with that of an adjacent residential district, where no street or alley separates the two, a buffer a minimum of twenty-five (25) feet is required. The buffer must contain either an eight (8) foot solid fence or a solid evergreen hedge.
3. Food, fuel and sporting goods stores, laundromats, dry cleaners and similar convenience and service shops may be permitted in recreational parks containing fifty (50) or more vehicle sites, provided that such shops and the parking area required by the use shall not occupy more than ten (10) percent of the total area of the recreational vehicle park; and,
4. Management offices and storage, playground and picnic equipment, sanitation and laundry facilities, informational signs and other structures customarily associated with a recreational vehicle park shall be considered incidental, permitted accessory uses.

3.7.4 Site plan requirements

All recreational vehicle park developments must provide a site plan as required by the Staff.

3.8 **SATELLITE DISH ANTENNA**

These regulations shall apply to satellite dish antenna and other satellite reception devices greater than two (2) feet in diameter.

3.8.1 General purposes

The regulations of this Section are designed to promote public health and safety by providing criteria for the placement of these antennas that ensures all such installations are performed in a manner that limits endangerment of life and property on the site and surrounding properties due to collapse or destruction.

These regulations are also designed to decrease the potential for urban blight in residential neighborhoods generated by guy wires, poles, cables, and other appurtenances.

These regulations are intended to allow satellite dish antenna and other satellite reception devices to be located in a manner that: (1) does not unreasonably delay or prevent the installation, maintenance or use of the antenna; (2) does not unreasonably increase the cost of installation, maintenance or use of the antenna; or (3) preclude reception of an acceptable quality signal.

3.8.2 General requirements

No person shall install a satellite dish antenna greater than two (2) feet in diameter without first obtaining an Improvement Location Permit.

All satellite dish antennas shall be installed and maintained in compliance with all applicable building and electrical codes, and shall be subject to the following standards.

1. Satellite dish antennae shall be solid in color.
2. Satellite dish antennae must be permanently mounted.
3. Not more than one (1) antenna greater than two (2) feet in diameter shall be allowed on any lot unless shown on an approved site plan.

Satellite dish antenna may be erected in any residential zoning district provided the following criteria are met.

4. The satellite dish antenna shall be ground mounted.
5. The diameter shall not exceed ten (10) feet.
6. The height of a ground-mounted antenna shall not exceed twelve (12) feet.
7. It shall be located between the rear building line of the principal structure and the required rear yard setback line.
8. In the R-3 Residential District, a satellite dish antenna may be roof mounted provided the diameter does not exceed ten (10) feet, and the height of the antenna does not exceed twelve (12) feet. A roof mounted satellite dish antenna shall be located at least ten (10) feet behind the front roofline of the structure. Notwithstanding the foregoing, a roof-mounted antenna shall not exceed the maximum building height requirement of the zoning district within which it is located.

Satellite dish antenna may be erected in any non-residential zoning district provided the following criteria are met.

9. The diameter shall not exceed twelve (12) feet.
10. The height of a ground-mounted antenna shall not exceed twenty-five (25) feet.
11. The height of a roof-mounted antenna shall not exceed fifteen (15) feet. Notwithstanding the foregoing, a roof-mounted antenna shall not exceed the maximum building height requirement of the zoning district within which it is located. Furthermore, a roof mounted satellite dish antenna shall be located at least ten (10) feet behind the front roofline of the structure.
12. A ground-mounted antenna shall comply with the yard setback requirements of the district within which it is located; however, no antenna shall be located in any required front yard or required open space.

3.9 AMATEUR RADIO ANTENNA

Amateur radio serves the community by providing emergency communications that benefit White County. The County supports these valuable community services and therefore, individual amateur transmitting and receiving antennae and associated support structures owned or operated by licensed amateur radio operators shall be permitted as accessory structures in accordance with these provisions.

Amateur Radio Club and repeater station antennae and support structures are permitted to such a height as necessary to maintain reliable communications.

Antenna structures of amateur radio operators licensed by the Federal Communication Commission (FCC) may, as of right, have a height not exceeding seventy-five (75) feet above grade. The height shall be measured vertically and shall include the height of any building upon which the antenna support structure is mounted.

Antennae may be located above the antenna support structure as reasonably necessary for effective radio communications.

Upon the Federal Communication Commission (FCC) licensed operator's cessation of ownership or leasehold rights in the subject antenna support structure, or on loss of his or her federal amateur radio license (whichever occurs first), the operator shall forthwith (but in no case more than thirty (30) days) safely remove all antenna support structures at no expense to the County. In the event that the operator fails or refuses to remove the antenna support structure, then the owner of the subject lot shall be responsible for the removal of all such structures.

On residential lots, any antenna support structure shall be located in an area between the rear building line of the principal structure and the required rear yard setback line.

Nothing in this Section shall affect any existing antenna support structure utilized by any federally licensed amateur radio operator, which has been constructed and is in place prior to the passage of this Ordinance.

3.10 WIRELESS SUPPORT STRUCTURES AND WIRELESS FACILITIES

3.10.1 Purpose, authority, and jurisdiction

A. Purpose

The purpose of this Section is to regulate the placement, construction, and modification of wireless support structures and wireless facilities in order to protect the public health, safety and general welfare of the community, while accommodating the need for telecommunication services. Regulation of the siting of wireless support structures and wireless facilities is an exercise of valid police power stipulated in the Federal Telecommunications Act of 1996 and delegated by the State of Indiana to local authority as provided for in IC 36-7 and IC 8-1-32.3-18 (1). The developer has the duty of compliance with reasonable conditions laid down by this Ordinance.

B. Written Notice

In all cases where a written notice is required for the purpose of providing an application determination, the written notice shall state clearly the basis for its decision to approve or deny an application. In the case of denial, the written notice must include substantial evidence in support of the denial. For purposes of written notification, minutes of a public meeting of a permit authority satisfies this requirement.

C. Confidentiality

Any information provided as part of an application referenced in this section which an applicant considers confidential or proprietary must be clearly marked as such. These documents will be protected under the departmental guidelines for protection of confidential or proprietary material.

D. Authority

As designated by Section 3.10, the Executive Director, Office Administrator, Area Plan Commission and Area Board of Zoning Appeals are hereby vested with the authority to review and approve/deny applications for the following as provided for in Sections 3.10.2, 3.10.3, 3.10.4 and 3.10.5 of this Chapter:

1. Construction of a new wireless support structure;
2. Collocations of wireless facilities on an existing structure;
3. Substantial modification of a wireless support structure; and,
4. Location of a small cell facility including a micro wireless facility.

For purposes of Section 3.10, the term “application” refers to an Improvement Location Permit (ILP) application and/or Building Permit (BP) application as established by the context of its use.

E. Jurisdiction

These regulations apply to all wireless support structures and wireless facilities as defined in Chapter 14, Definitions, located within the jurisdiction of the White County Area Plan Commission.

F. With the exception of non-commercial wireless facilities, no building mounted communications antennas shall be located on any single-family or two-family dwelling.

G. Approval – Other

Subject to subsection H below, an approval permit or waiver is required from the local highway or street department, whichever is appropriate, any time work is to be performed within a road buffer zone. This permit does not preclude the requirement of obtaining consent from the owner of:

- 1) private property;
- 2) a private utility pole; or,
- 3) a privately-owned wireless support structure.

H. Exclusions

A permit authority may not require an application or a permit for, or charge fees for, any of the following:

- 1) The routine maintenance of wireless facilities.
- 2) The replacement of wireless facilities with wireless facilities that are:
 - (A) Substantially similar to; or
 - (B) The same size or smaller than the wireless facilities being replaced.
- 3) The installation, placement, maintenance or replacement of micro wireless facilities that are suspended on cables strung between existing utility poles in compliance with applicable codes by a communications service provider that is authorized to use the public rights-of-way. For purposes of this subsection, "applicable codes" means uniform building, fire, electrical, plumbing or mechanical codes that are:
 - (A) Adopted by a recognized national code organization; and,
 - (B) Enacted solely to address imminent threats of destruction of property or injury to persons; including any local amendments to those codes.
- 4) The installation, location, or use of wireless service facilities on utility poles or electrical transmission towers.

I. Prohibitions

The Area Plan Department may not require an applicant to submit information about an applicant's business decision with respect to the applicant's designed service, customer demand, service quality or desired signal strength to a particular location, nor may the Area Plan Department evaluate such information.

3.10.2 NEW WIRELESS SUPPORT STRUCTURES AND WIRELESS FACILITIES

3.10.2.1 Application and Approval Procedure

A. Application Review

The Executive Director shall approve/deny completeness of all applications for any new wireless support structure and/or wireless facility. All applications shall be reviewed and determination for completeness made within ten (10) business days from its receipt. If the application is not complete, the Executive Director shall notify the applicant in writing of all defects in the application. Unless notified in writing otherwise, an applicant has thirty (30) days from receiving notice of the application status to cure the defects in the application. If the applicant cannot meet the thirty (30) day period, the applicant shall notify the Staff of the additional time the applicant requires to cure the defects. The Executive Director shall approve or deny the application within ninety (90) days after the

date of the original determination adjusted by any amount of time required by the applicant to cure defects of the application.

B. Application requirements

Any person or entity desiring to establish a new wireless support structure and/or wireless facility, whether a permitted use or a special exception use, is required to apply for and obtain an Improvement Location Permit (ILP) from the Staff. An ILP application, along with all supporting documents, including the applicable filing fee, must be submitted to the Area Plan Office for consideration. It is the responsibility of the applicant to complete the application and provide the information necessary to satisfy all application requirements. Upon determination as complete, the Staff will compile the application packet for presentation to the Area Plan Commission which will consider the application at a scheduled public hearing for approval or denial. Each application must include the following information:

1. The owner/operator's name, business address and point of contact for the applicant;
2. The location (address and parcel #) of the proposed wireless support structure and/or wireless facilities; and,
3. A construction plan that describes the proposed wireless support structure and all equipment and network components, including antennas, transmitters, receivers, base stations, power supplies, cabling and related equipment. Such construction plan shall be certified with an engineer's seal, registration number and signature and include the following information and documents:
 - a) Certification that the proposed installation will not exceed the structural capacity of the wireless support structure taking into consideration wind and other load variables associated with the construction and installation of said structure;
 - b) A layout drawing showing the wireless support structure's height, elevation and construction design;
 - c) Documentation of the steps the applicant will take to avoid interference with established public safety telecommunications;
 - d) A site development plan which meets the requirements and information listed below:
 - 1) Location and approximate size and height of all buildings and structures located within five hundred (500) feet of the proposed wireless equipment compound;
 - 2) A detailed layout of the entire development, indicating all improvements, including all proposed landscaping, screening and access points;
 - 3) Elevations illustrating all facades and indicating exterior materials and color of the proposed wireless support structure; and,
 - 4) Drawings to a scale of no smaller than one (1) inch equals fifty (50) feet;

- e) A copy of the FAA's (Federal Aviation Administration) response to the submitted "Notice of Proposed Construction or Alteration" (FAA Form 7460-1 as amended from time to time);
- f) Certification of compliance with applicable Federal Communications Commission (FCC) regulations;
- g) A Decommissioning Plan meeting the minimum standards of Chapter 3, Section 3.10, Subsection 3.10.2.3 F and satisfactory to the Area Plan Commission or one which has been approved by the governmental entity under which the subject property lies;
- h) A report from a qualified and licensed professional engineer which demonstrates the facilities' design compliance with the State's structural and electrical standards;
- i) If the applicant is not the property owner, a copy of an executed lease agreement or letter of authorization between the applicant and the property owner pertaining to the siting of a wireless support structure and/or wireless facilities on the subject property;
- j) Evidence of agreements and/or easements necessary to provide access to the wireless support structure, building, water tower or other structure on which the antennas are to be mounted so that installation and maintenance of the antennas and communications equipment and/or building can be accomplished.
- k) Certification that the wireless support structure will be built to manufacturer standards and specifications; and,
- l) Any other information requested by the Executive Director, the Area Plan Commission, and/or the Area Board of Zoning Appeals to allow proper evaluation of the request.

4. "Good Faith Certification" Evidence supporting the choice of location for the proposed wireless support structure, including a sworn statement from the individual responsible for the choice of location demonstrating that collocation of wireless facilities on an existing wireless support structure, utility pole or electrical transmission tower is not a viable option because collocation:

- a) Would not result in the same wireless service functionality, coverage and capacity;
- b) Is technically infeasible; or,
- c) Is an economic burden to the applicant.

5. If the proposed site is subject to Special Exception Use approval, evidence that the application complies with the criteria set forth in the Ordinance with respect to the special exception use via a certification from the Staff that such approval has been obtained from the Area Board of Zoning Appeals

C. Area Plan Commission (APC) Approval/Denial

Within ninety (90) days from the date the application is determined to be complete, the Area Plan Commission shall approve or deny the application request. Prior to making a determination, the APC shall:

1. Review the application to determine if it complies with all applicable laws and ordinances governing land use and zoning; and,
2. Evaluate all documents and testimony associated with the subject application.

After the Area Plan Commission's hearing and evaluation, the APC will make a determination of approval or denial of the request.

After determination, the Staff will provide notification to the applicant, in writing, whether the application request is approved or denied. In the case of denial, the applicant must be provided written notice of the denial; this notice must state clearly the basis for the decision and provide substantial evidence in support of the denial.

Note: Minutes of the public meeting which contain the causes of denial satisfy the notice requirements of this Subsection.

Upon request of the applicant, the Area Plan Commission shall continue the hearing in order to provide additional time for the applicant to provide any clarification needed or cure any defects in the application, supplemental documents, other applicant submissions, or hearing testimony. The Area Plan Commission determination of the request is extended for a period equal to the extension period requested by the applicant. The applicant is limited to no more than two such continuances.

3.10.2.2 General Approval Standards

Approval of a new wireless support structure and/or wireless facility also requires the following items/requirements be met:

- A. The location of the proposed wireless support structure and/or wireless facility is compatible with White County's Comprehensive Plan;
- B. The proposed wireless support structure and/or wireless facility shall not unreasonably interfere with the view from any public park, natural scenic vista, historic building or district, or major view corridor and may not be located in a FEMA designated Flood Hazard Area, zone "AE", without certification from the Floodplain Administrator that the facility/structure meets current standards for flood proofing and elevation;
- C. At a minimum, the wireless equipment compound shall be visually enclosed as required by Chapter 9, Landscape Standards (not required for wireless facilities or structures locating within a public rights-of-way or road buffer zone);
- D. The height and mass of the wireless support structure and/or wireless facilities do not exceed that which is essential for their intended use and to assure public safety;
- E. Except where required otherwise by the FAA, the proposed wireless facilities (excluding the wireless support structure) shall be painted silver or have a galvanized finish retained in order to reduce visual impact. The wireless equipment compound shall have a security fence with an access gate along the entire

perimeter of the lot, parcel or leased area where the wireless support structure and/or wireless facility are located (not required for wireless facilities or wireless structures locating within a public rights-of-way or road buffer zone);

- F. The wireless support structure and/or wireless facilities are in compliance with all other applicable local, state, or federal regulations; and,
- G. Any proposal to locate wireless facilities and/or a wireless support structure in a public right-of-way must provide the following:
- 1) A decommissioning plan approved by the entity that owns or controls the subject rights-of-way;
 - 2) An executed lease agreement with the entity that owns or controls the rights-of-way or a letter from said entity that they are not requiring such agreement;
 - 3) A construction plan approved by the entity that owns or controls the rights-of-way; such plan must contain assurances to protect any and all improvements within the rights-of-way and which provides guarantees to replace or repair any and all improvements effected by the construction/installation process; said improvements shall include, but are not limited to, utility infrastructure, road pavement, berms, shoulders, curbs and sidewalks;
 - 4) An installation plan approved by every utility with infrastructure or facilities located within two hundred (200) feet of the proposed wireless facilities or wireless support structure location;
 - 5) Proof of insurance satisfactory to the entity that owns the rights-of-way and annual proof that such policy remains in effect throughout the life of the wireless facilities or wireless structure; failure to maintain said policy shall trigger a requirement to decommission the wireless facilities and/or wireless structure as provided for during the approval process;
 - 6) Construction must be of monopole design;
 - 7) Any ground mounted cabinet is limited to forty (40) cubic feet in volume and forty-eight (48) inches in overall height;
 - 8) Each wireless support structure must have a permanent identification plaque mounted on the pole so that it can be seen and read from the road pavement but which does not exceed forty-five (45) square inches in size; said plaque shall contain the owner's name and owner's full address and phone number; and,
 - 9) All wiring and fiber shall be concealed within the support structure and all conduit, wiring and fiber exterior to the wireless structure and within the public rights-of-way shall be buried in their entirety.

3.10.2.3 General performance standards

A. Height and setback requirements

1. In all zoning districts, not including districts within a public rights-of-way or portion within a road buffer zone, the maximum height of any wireless support structure shall be three hundred (300) feet;
2. In all public rights-of-ways or road buffer zones, regardless of zoning district classification, the maximum height of any wireless support structure shall be fifty (50) feet as measured from grade or the height of any utility pole in place on July 1, 2017 and within five hundred (500) feet of the proposed location, plus 10 feet;
3. In all zoning districts, not including a public rights-of-way or portion within a road buffer zone, the base, including the foundation, of any wireless support structure shall be set back a distance equal to the height of the wireless support structure or its fall zone area, whichever is less restrictive, unless specifically allowed elsewhere in this Section (the wireless support structure fall zone area is established as set forth in the applicant's engineering "fall zone area" certification unless the permit authority provides evidence that the applicant's engineering certification is flawed);
4. In all public rights-of-ways, the location of the base, including the foundation, of any wireless support structure shall be established by the governmental body or department having jurisdiction over the public rights-of-way. In all road buffer zones, the closest point of the base, including the foundation, of any wireless support structure and/or facilities shall be set back a minimum of eight (8) feet from the edge of pavement or in line with the nearby utility poles, whichever provides the greatest distance from the road pavement. No wireless support structure is permitted in a road buffer zone which is part of a residential zoning district unless authorized by the Area Board of Zoning Appeals or provided for elsewhere in this Section.
5. In all cases, excluding those pertaining to a public rights-of-way or road buffer zone, where a subject site has one or more property lines in common with a property, or properties, assigned an A-1, A-2, I-2 or I-3 zoning district, the setback to that (those) specific property line(s) may be altered subject to the following conditions:
 - a) The setback is not reduced to less than fifty (50) feet; and,
 - b) At least one property owner of the abutting parcel with the common property line provides to the Staff an executed, notarized letter, which includes a written statement which provides the specific setback to be applied and that all property owners of that abutting parcel have agreed to the altered allowance; and,
 - c) The setback alteration is not applied to any property line which abuts a road;

6. In all cases, the components of all wireless facilities are subject to the accessory structure setback requirements of the site's zoning district assignment for accessory structures; and,
7. Unless specifically provided for elsewhere, all setbacks are measured from lot/parcel property lines or road rights-of-way lines, whichever are most restrictive (lease lines vs individual structures may be utilized for the purpose of demonstrating compliance to setback requirements).

B. Location

1. It is encouraged that antennas be placed upon existing structures, including, but not limited to, building rooftops, water towers, utility poles, electrical transmission towers or existing wireless support structures instead of building new structures.
2. A wireless support structure or wireless facilities may be located on a lot or parcel occupied by a principal structure and may occupy a leased area of said lot or parcel. In those instances, the required setback between the wireless support structure and the principal structure shall be no less than the equivalent of the height of the tower or the fall zone area, whichever is least restrictive.
3. Execution of a subdivision shall not be required to provide for a "leased parcel" on which a wireless support structure and/or a wireless facility is proposed to be constructed, provided the wireless facilities are unmanned.
4. There will be a minimum separation of one thousand (1,000) feet between any two wireless support structures as measured radially from the center of each structure.

C. Access to facility

Access shall be provided to the facilities by means of a public street or easement to a public street. The easement shall be a minimum of twenty (20) feet in width and shall be improved to a width of at least twelve (12) feet with gravel or pavement for its entire length.

D. Landscaping/Security

Except in the case of wireless facilities or wireless structures located in a public rights-of-way or road buffer zone, wireless structures and facilities shall be screened and secured in accordance with the provisions of Chapter 9, Section 9.3, Subsection 9.3.7 of Landscaping Standards.

E. Wireless support structure lighting and signs

No signs or lights shall be mounted on a wireless support structure, except as may be required by the Federal Communications Commission, Federal Aviation Administration or other governmental agency which has jurisdiction.

F. Abandonment

An abandoned or unused wireless support structure or wireless facilities or portions thereof must be decommissioned as approved by the Area Plan Commission at the time of application approval or, if no such decommissioning plan exists, as follows:

1. The applicant or subsequent owner/lessor shall remove all abandoned or idled wireless support structures and/or wireless facilities, or portion thereof, within one hundred and eighty (180) days of the cessation of their use at the site unless the Executive Director, in writing, approves a time extension;
2. Upon decommissioning and removal of all wireless support structures and wireless facilities, the site will be returned to its preconstruction condition, as near as possible, in the context of soil quality, topography and vegetation;
3. Any and all expenses from the decommissioning effort shall be borne by the applicant or their successor;
4. In the event that the abandoned or idled wireless support structure and/or wireless facilities, or portion thereof, are not removed within one hundred eighty (180) days of the cessation of their use at a site, the failure will be considered a civil zoning violation. The County reserves the right to remove the wireless support structure and/or wireless facilities, or portion thereof, at any time after cessation of operations with any and all costs of removal assessed against the operator and/or owner of the wireless structure(s) and/or wireless facilities.

3.10.3 EXISTING WIRELESS SUPPORT STRUCTURE AND/OR WIRELESS FACILITY (SUBSTANTIAL MODIFICATION)

3.10.3.1 Application and Approval Procedure – Modifications, Site Improvement Upgrades, Facilities Alteration/Upgrade & Equipment Revisions

A. Application Review

The Executive Director or Office Administrator shall approve/deny all applications for a wireless support structure or wireless facilities modification, substantial or otherwise, including, but not limited to, site improvement upgrades & equipment revisions. All applications shall be reviewed and determination for completeness made within ten (10) business days from its receipt. If the application is not complete, the Executive Director or Office Administrator shall notify the applicant in writing of all defects in the application. Unless notified in writing otherwise, an applicant has thirty (30) days from the date of application status notice to cure the defects in the application. If the applicant cannot meet the thirty (30) day deadline, they may request, in writing, up to, but no more than, (90) days to resolve any application defects.

B. Application Requirements

Unless exempted elsewhere in Section 3.10, any time a legally existing wireless support structure and/or wireless facilities is subject to modification, site improvement upgrades, facilities alteration/upgrade, upgrade and/or equipment revision, an Improvement Location Permit (ILP) is required. (Any building or structure new construction, remodel, alteration, expansion or modification is subject to the White County Indiana Building Code Ordinance as amended from time to time and will require a Building Permit.) An ILP application, along with all supporting documents affiliated with such application, including the applicable filing fee, must be submitted to the Area Plan Office for review and approval/denial. In addition, each application must include the following information:

1. The owner/operator's name, business address and point of contact for the applicant;

2. The location address and parcel # of the proposed or affected wireless support structure or wireless facility;
3. A construction plan that describes the proposed construction, modifications, upgrades, alterations or revisions to the wireless support structure and/or all equipment and network components, including antennas, transmitters, receivers, base stations, power supplies, cabling and related equipment. Such plan must include:
 - a) Engineer's report (if applicable) - A report from a qualified and licensed professional engineer which certifies that the proposed construction, installations, alterations, modifications, revisions or upgrades will not exceed the structural capacity of the wireless support structure to which equipment is intended to be mounted considering wind and other load variables associated with the site location and the construction design of the wireless support structure;
 - b) A certification from the installer or applicant that the site will be in compliance with the requirements of all Federal, State and Local laws, and all government department and agency rules and regulations to avoid interference with established public safety telecommunications; and,
 - c) A site plan which provides:
 - (1) The physical location on the property of any new wireless support structure or wireless facilities to be added as a part of the proposed scope of work;
 - (2) The overall height of the wireless support structure and, for each antenna to be added, the location from ground level of said antennas; and,
 - (3) Any other information requested by the Executive Director, Office Administrator, Area Plan Commission, and/or Area Board of Zoning Appeals in order to properly evaluate the application.

C. Executive Director Approval/Denial

Within ninety (90) days from the date the application is determined to be complete, the Executive Director or Office Administrator shall:

1. Review the application to determine if it complies with all applicable laws and ordinances governing land use and zoning; and,
2. Evaluate all documents and information associated with the subject application.

After evaluation, the Executive Director or Office Administrator will make a determination of approval or denial of the request.

After determination, the Staff will provide notification to the applicant, in writing, whether the application request is approved or denied. In any case of denial, this notice must state clearly the basis for the decision and provide substantial evidence in support of the denial.

Notwithstanding the ninety (90) day period set forth in Section 3.10.3.1 (C), an applicant can request additional time to cure defects in the application which will automatically extend the determination deadline by an amount equal to the extension granted.

3.10.4 Application and Approval Procedure – Collocations

A. Application Review

The Executive Director or Office Administrator shall approve/deny all applications for collocations. All applications shall be reviewed and determination for completeness made within ten (10) business days from its receipt. If the application is not complete, the Executive Director or Office Administrator shall notify the applicant in writing of all defects in the application. Unless notified in writing otherwise, an applicant has fifteen (15) days from the date of application status notice to cure the defects in the application. If the applicant cannot meet the fifteen (15) day deadline, they may request, in writing, additional time to cure any application defects. The fifteen (15) day deadline is extended for a period of time equal to the request of the extension.

B. Application requirements

All requests for collocations, whether applicable to a building, an existing wireless support structure and/or facilities or other structure, are required to obtain an Improvement Location Permit (ILP). An ILP application, along with all documents required by such application, including the applicable filing fee, must be submitted to the Area Plan Office for review and approval/denial. (Any building or structure construction, remodel, alteration, expansion or modification is subject to the White County Indiana Building Code Ordinance as amended from time to time and will require a Building Permit.) In addition, each application must include the following information:

1. The owner/operator's name, business address and point of contact for the applicant;
2. The location address and parcel # of the proposed collocation site; and,
3. If applicable, evidence of conformance with applicable building permit requirements.

An application for a permit for collocation:

- (1) is not required to comply with zoning or land use requirements; and
- (2) is not subject to a public hearing.

Note: Applicants are allowed to submit a single application and receive a single permit for multiple collocations at multiple sites as long as all sites are within the jurisdiction of the Area Plan Commission.

C. Executive Director/Office Administrator Approval/Denial

Within forty-five (45) days from the date the application is determined to be complete, the Executive Director or Office Administrator shall approve or deny the application request in writing. However, if the applicant requested additional time under subsection (e) to cure defects

in the application, the forty-five (45) day period is extended for a corresponding amount of time. Prior to making a determination, the Executive Director or Office Administrator shall:

1. Evaluate all documents and information associated with the subject application.

After evaluation, the Executive Director or Office Administrator will make a determination of approval or denial of the request.

After determination, the Staff will provide notification to the applicant, in writing, whether the application request is approved or denied. In any case of denial, the applicant must be provided written notice of the denial; this notice must state clearly the basis for the decision and provide substantial evidence in support of the denial.

3.10.5 Construction, Placement or Use of Small Cell Facilities

A. Prohibitions:

- 1) No new utility pole or new wireless support structure may be placed within rights-of-way within an area that is designated strictly for underground or buried utilities without approval of a variance from the Area Board of Zoning Appeals. The subject area must have been dedicated before May 1, 2017. This prohibition is subject to the requirements and standards provided for in IC 8-1-32.3-15 as amended from time to time.
- 2) Small cell facilities may not be collocated on any:
 - a) privately owned utility pole;
 - b) privately owned wireless support structure; or,
 - c) private property; without consent of the owner of the utility pole, wireless support structure or property, as applicable.

B. Application Review

Unless explicitly prohibited elsewhere in this Section, the Executive Director or Office Administrator shall approve/disapprove all applications for construction, placement or use of Small Cell Facilities. All applications shall be reviewed and determination for completeness made within ten (10) business days from its receipt. If the application is not complete, the Executive Director or Office Administrator shall notify the applicant in writing of all defects in the application. Unless notified in writing otherwise, an applicant has fifteen (15) days from the date of application status notice to cure the defects in the application. If the applicant cannot meet the fifteen (15) day deadline, they may request, in writing, additional time to cure any application defects.

C. Application Requirements

Any time small cell facilities are subject to department approval, an Improvement Location Permit (ILP) is required. An ILP application, along with all documents required by such application, including the applicable filing fee, must be submitted to the Area Plan Office for review and approval/denial. An applicant is allowed to submit a single consolidated application for multiple small cell facilities under issuance of a single permit for the small cell network; the fee charged in such case shall be based on the number of

small cell facilities covered under the application. In addition, each application must include the following information:

1. The owner/operator's name, business address and point of contact for the applicant;
2. A location map identifying the specific location of each small cell facility and/or structure subject of the permit application;

In the case where a permit includes the location of one or more new support structures, a development plan which includes the following:

- a) The overall height of each proposed wireless support structure and the location and height of surrounding structures (those within 500 feet of the proposed location) when applicable;
- b) The distance from the closest point of the wireless support structure to each parcel line or rights-of-way line, whichever is most restrictive; and,
- c) In cases of location on private property, a notarized letter of authorization from the property owner.

Exemption: The placement of a small cell facility and associated supporting structure in a public rights-of-way is exempt from zoning review if the total height of the supporting structure does not exceed the greater of fifty (50) feet as measured from grade or the height of any utility pole (plus ten (10) feet) in place on July 1, 2017 and within five hundred (500) feet of the proposed small cell facility.

In all cases where an application is for construction, placement or use of a small cell facility and a supporting structure at a location where a supporting structure does not exist, the Executive Director or Office Administrator may propose an alternative location for the proposed small cell facility or that the small cell facility be collocated on an existing utility pole or an existing wireless support structure as long as such pole or structure is located within fifty (50) feet of the proposed location. The applicant shall use the alternative location proposed by the Executive Director or Office Administrator if:

1. The applicant's right to use the alternative location is subject to reasonable terms and conditions; and,
2. The alternative location will not result in technical limitations or additional costs, as determined by the applicant

C. Executive Director/Office Administrator Approval/Denial

Within sixty (60) days from the date the application is determined to be complete or sixty (60) days plus the extended time granted to the applicant to cure application defects, the Executive Director shall approve or deny the application request. Prior to making a determination, the Executive Director or Office Administrator shall:

1. Review the application to determine if it complies with all applicable laws and ordinances governing land use and zoning; and,
2. Evaluate all documents and information associated with the subject application.

After evaluation, the Executive Director or Office Administrator will make a determination of approval or denial of the request.

The evaluation process may not do any of the following:

1. Limit the placement of a small cell facility by minimum separation distances or maximum height limitations;
2. Impose unreasonable requirements regarding the maintenance or appearance of the small cell facility and associated supporting structure, including requirements concerning the types of materials to be used or the screening or landscaping of the location;
3. Condition the approval on the applicant's agreement to allow other wireless facilities to be placed at, attached to, or located on the associated wireless support structure or utility pole;
4. Limit the duration of any permit granted subject to construction commencing not later than two (2) years after the date the permit is granted;
5. Prohibit an applicant from locating a small cell facility, wireless support structure or utility pole in a residential area;
6. Impose setback or fall-zone requirements for the associated wireless support structure or utility pole that are different from requirements imposed on other types of structures in a public right-of-way; or,
7. Require the removal of existing wireless support structures, wireless facilities, or utility poles as a condition for approval of the application; subject to the decommissioning rules of Section 3.10 of this Chapter.

Every application intended for location within a public right-of-way, is subject to reasonable and generally applicable safety regulations under IC 8-1-2-101 (b) as amended from time to time.

Any construction, placement or use of small cell facilities on a utility pole owned or controlled by a governmental unit is subject to the following:

- 1) The rate charged by the governmental unit may not exceed fifty dollars (\$50) per utility pole per year;
- 2) For a utility pole used to provide communications or electric service, all parties to the construction, placement or use shall comply with the process for make ready work under 47 U.S.C 224 and any associated implementing regulations (The good faith estimate of the unit owning or controlling the utility pole with respect to any make ready work necessary to enable the utility pole to support the requested replacement must include pole replacement if necessary);
- 3) For a utility pole that does not support aerial facilities used to provide communications service or electric service, the unit shall provide a good faith estimate for any make ready work necessary to enable the utility pole to support the requested construction, placement, or use, including pole replacement, if necessary, not later than sixty (60) days after the unit's receipt of a complete application from the Staff; all make ready work shall be

completed within sixty (60) days after the applicant's written acceptance of the good faith estimate;

- 4) The unit shall not require more make ready work than required to meet applicable codes or industry standards. Fees for make ready work may not include costs related to preexisting or prior damage or to noncompliance. Fees for make ready work, including any utility pole replacement, may not:
 - (a) Exceed actual costs or the amount charged to communications providers for similar work; or,
 - (b) Include any consultants' fees or expenses.
- 5) Subject to subdivision 7 below, the unit shall offer rates, fees and other terms for construction, placement or use that comply with this Chapter and Section. Not later than December 31, 2017 or three (3) months after receiving the first request under this chapter for the construction, placement or use of a small cell wireless facility on a utility pole owned or controlled by the unit; whichever occurs later, the unit shall make available by ordinance or otherwise, the rates, fees and terms that govern the construction, placement or use of small facilities on utility poles owned or controlled by the unit and that are in compliance with Section 3.10 of this Chapter.
- 6) The unit or a utility owned by the unit shall not impose a rental or other reoccurring fee for small cell facilities that are strung or located between utility poles if one (1) or more of the utility poles has an associated attachment for which a rental rate is charged.
- 7) The unit may impose additional general terms and conditions for the construction, placement or use of small cell facilities on utility poles owned or controlled by the unit if the additional general terms and conditions are:
 - (a) consistent with Chapter 3, Section 3.10;
 - (b) reasonable;
 - (c) nondiscriminatory; and,
 - (d) generally applicable to users of rights-of-way.

Additional general terms and conditions authorized by this subsection, must be included in the rates, fees and terms that the unit is required to establish and make available under subsection 5 above.

3.11 **EXTRACTIVE MANUFACTURING**

All potential Extractive Manufacturing operations require development plan approval by the Area Plan Commission and the appropriate legislative body prior to the commencement of site activities. Each Development Plan shall include, but is not limited to, the following:

- A Drainage Plan Letter of Approval from the White County Drainage Board,
- Setback distances from property lines for mining and crushing activities,
- Egress-Ingress location(s) and dimensional specifications,

Landscape plan,
Blasting parameters and schedule limitations,
Dust suppression plans,
Reclamation plan,
Berms/Fencing and other relevant perimeter safeguards,
Commitments & conditions offered,
Contingency plan for potential hazards,
Plan of protection of surrounding and adjacent properties,
Road use agreement, traffic plan & maintenance and repair bond,
Contact information for operating parties (notification of any changes required within five (5) working days of the effective change date),
Contact information for main office (if off-site), and
Any other reasonable requirements requested by the Area Plan Commission or Staff.

3.12 **DIGESTERS, AEROBIC OR ANAEROBIC**

Aerobic Digester:

1. Zoning District: Permitted: A-2 or I-2 Accessory Use: A-1, A-2, I-1, I-2
2. Minimum setback for all facilities where processing occurs and/or storage of any nature is as follows:
 - a. * Any Front Property Line: One hundred (100) feet
 - b. * Any Side Property Line: Two hundred (200) feet
 - c. * Any Rear Property Line: Two hundred (200) feet
 - d. * Any residential district boundary line or any other residence, excluding those located on the same property: One thousand (1,000) feet unless the owner of such residence or residential property waives such restriction in notarized form to the Area Plan Office.
 - e. * All other structures shall comply with the setback requirements as provided for in Appendix B Bulk Use Standards of the White County Indiana Zoning Ordinance.
 - f. * Lagoons must have no boundary closer than one thousand (1,000) feet to any property line.
3. Minimum Area: 10 Acre parcel which does not exceed a three to one ratio as determined by the shortest distance between the front and rear property lines and the shortest distance between the side property lines. A parcel shall not be

required to meet such standard should said parcel have been created prior to January 1, 2009.

4. * Applicant must provide any and all approval certificates from IDEM to demonstrate compliance with all IDEM requirements.
5. * No facilities or structures, principal or accessory, may be located within one mile from an incorporated municipality boundary line unless the appropriate legislative body waives this requirement via official notice to the Area Plan Department.
6. A transportation plan must be submitted prior to the issuance of an improvement location permit detailing the effect of the development on local roadways, including before and after construction traffic volume, impact on road maintenance, congestion and noise.
7. A general operational plan must be submitted which describes the processing steps, the waste streams intended to be used and their sources plus any additional pertinent information related to how the facility will operate.
8. * Site shall comply with the landscaping requirements of Table 9:1 and with the applicable sections of Chapter 8 of the White County Indiana Zoning Ordinance.
9. The applicant shall submit a decommissioning plan to the Area Plan Commission for approval. The plan must be in compliance with IDEM requirements for the removal of the digester facility and its supporting accessory structures for when it becomes functionally obsolete or is no longer in use.
10. * Lot coverage and any other developmental standards not listed in this section shall be established by the standards specified in the White County Indiana Zoning Ordinance.
11. Only those requirements designated with an “*” apply to a digester utilized as an accessory use to an on-site principal use.
12. No digester will be allowed within any municipality boundary unless owned and operated in conjunction with the municipality government.
13. A digester which falls within any municipality boundary which is owned and operated in conjunction with a municipality government is exempt from the requirements of this section.

Anaerobic Digester:

14. Zoning District: Permitted: A-2 or I-2 Accessory Use: A-1, A-2, I-1, I-2
15. Minimum setback for all facilities where processing occurs and/or storage of any nature is as follows:
 - a. * Any Front Property Line: One hundred (100) feet
 - b. * Any Side Property Line: Two hundred (200) feet
 - c. * Any Rear Property Line: Two hundred (200) feet

- d. * Any residential district boundary line or any other residence, excluding those located on the same property: Five hundred (500) feet unless the owner of such residence or residential property waives such restriction in notarized form to the Area Plan Office.
 - e. * All other structures shall comply with the setback requirements as provided for in Appendix B Bulk Use Standards of the White County Indiana Zoning Ordinance.
 - f. * Lagoons must have no boundary closer than five hundred (500) feet to any property line.
16. Minimum Area: Seven (7) Acre parcel which does not exceed a three to one ratio as determined by the shortest distance between the front and rear property lines and the shortest distance between the side property lines. A parcel shall not be required to meet such standard should said parcel have been created prior to January 1, 2009.
- 17.* Applicant must provide any and all approval certificates from IDEM to demonstrate compliance with all IDEM requirements.
- 18.* No facilities or structures, principal or accessory, may be located within one mile from an incorporated municipality boundary line unless the appropriate legislative body waives this requirement via official notice to the Area Plan Department.
19. A transportation plan must be submitted prior to the issuance of an improvement location permit detailing the effect of the development on local roadways, including before and after construction traffic volume, impact on road maintenance, congestion and noise.
20. A general operational plan must be submitted which describes the processing steps, the waste streams intended to be used and their sources plus any additional pertinent information related to how the facility will operate.
- 21.* Site shall comply with the landscaping requirements of Table 9:1 and with the applicable sections of Chapter 8 of the White County Indiana Zoning Ordinance.
22. The applicant shall submit a decommissioning plan to the Area Plan Commission for approval. The plan must be in compliance with IDEM requirements for the removal of the digester facility and its supporting accessory structures for when it becomes functionally obsolete or is no longer in use.
- 23.* Lot coverage and any other developmental standards not listed in this section shall be established by the standards specified in the White County Indiana Zoning Ordinance.
24. Only those requirements designated with an “*” apply to a digester utilized as an accessory use to an on-site principal use.
25. No digester will be allowed within any municipality boundary unless owned and operated in conjunction with the municipality government.

26. A digester which falls within any municipality boundary which is owned and operated in conjunction with a municipality government is exempt from the requirements of this section.

3.13 HOSPITAL AND MEDICAL, MENTAL HEALTH FACILITY (OR PSYCHIATRIC HOSPITAL)

Entrances and interior roads

1. Prior to issuance of an Improvement Location Permit and prior to construction of any Hospital or Medical, Mental Health Facility, the developer shall provide a letter from the appropriate municipal or county legislative body verifying the approval of the ingress-egress access design in addition to complying with all requirements of the White County Indiana Zoning Control Ordinance.

Thoroughfare plan

2. At the time of, or prior to, submission of development site plan, a detail thoroughfare plan must be submitted for review by the Staff. Such document will include, but is not limited to, a projection of increase passenger vehicle traffic, anticipated required road improvements, summary of expected delivery and operating vehicle traffic loads including emergency vehicles, potential impacts on surrounding sites and the community at large and anticipated frequency of hazardous material deliveries, including types of such materials. It will include accessibility impacts for taxis, busses and other public modes of transportation.

Heliport/Air service

3. A written notification of any air service to be utilized by the facility including the site details for handling such service.
4. Community impacts
5. Provide a written summary of impacts of the development on all types of pedestrian circulation in any area within two thousand five hundred (2,500) feet of all property boundaries. This shall include impacts on walking, non-motorized transportation, such as bicycles, and handicap accessibility.

3.14 I-3 ZONING DISTRICT

All I-3 Zoning Districts are subject to the standards of this Section. Where a conflict occurs between this section and any other requirement of the White County Indiana Zoning Control Ordinance, this section shall rule. These requirements are in addition to any and all other requirements provided for in this Ordinance.

A. Building Requirements

1. Prior to application for a Building Permit or Improvement Location Permit, each developer must provide a preliminary architectural plan which must include:
 - a. Elevations and/or renderings of the proposed building(s);
 - b. A conceptual floor plan;

- c. A rendering or artistic drawing of the proposed landscaping, parking, signage and any other exterior amenities planned for the site.
 2. The ground floor footprint for the principal building of each lot must be a minimum of thirty thousand (30,000) square feet.
- B. Accessory Building
 1. All accessory buildings, with the exception of a guard shack or similarly functioning type building, shall be located behind the rear building line of the principal structure. Guard shacks or similarly functioning type building must meet the front, side and rear setback requirements for an accessory structure as provided for in Appendix B: Bulk Use Standards.
 2. All non-building accessory structures shall be located behind the front building line of the principal structure.
 3. All accessory buildings shall be architecturally compatible with the principle building on the lot.
- C. Design Requirements
 1. Predominant building materials shall be naturalistic materials, such as brick and stone, decorative and/or painted pre-cast concrete panels or architectural metal panels.
 2. Any side of any building facing a highway or a road shall be constructed of precast concrete, tilt-up concrete, glass, brick, architectural metal panels, or combination thereof.
 3. Any portion of a front wall, façade or side wall of any building that is visible from the public right-of-way shall not be constructed of corrugated metal or aluminum siding, unpainted wood, wood shingles or exposed concrete or cinder blocks. Industrial grade, pre-engineered metal building siding may be utilized on walls not facing a public right-of-way.
 4. Roofs of one or two-story buildings shall have steep pitched roofs with hipped or gabled ends. Roof materials shall be traditional in composition and complement the architectural features of the building. Flat roofs are allowed provided that parapet walls or heavy cornices are utilized to screen all mechanical units.
 5. Windows, architectural detailing and the articulation of entrances shall be prominent and proportional with the building size and mass.
 6. Air conditioning units and/or equipment or other building affiliated structure, excluding rooftop equipment, which is visible on or near the exterior of the building shall be screened from the view of all streets/roads and adjoining properties.
 7. Any development required to orient their facilities facing US Highway 24 or Division Road must locate all truck docks and the dock area to the rear or side of such facility.

D. Site Requirements

1. Each principal building shall have a minimum height of 32', either at the roof line or the top of the parapet wall, excluding exclusive office areas.
2. All principal buildings north of the TP & WW RR Right-Of-Way shall be oriented toward US Hwy 24; all principal buildings north of and with lots or parcels adjacent to US Hwy 24 shall be oriented toward US Hwy 24; all principal buildings south of the TP & W RR shall be oriented toward Division Road.
3. All exterior lighting shall be directed internally upon each lot so as not to be directed on adjoining lots or streets/roads. Directly down or directly up parking lot lights are allowed. Lighting of exterior walls or signage must be direct lighting (wall packs discouraged).
4. Each site shall dedicate a minimum of fifteen percent (15%) of their total parcel area to greenspace (grass or vegetative ground cover).

E. Setbacks and Lot/Parcel Coverage

1. The perimeter of any parking lot or driveway area, excluding ingress/egress locations, shall be allowed within any front, side or rear setback as long as such perimeter is not closer than 10' to any property line or road right-of-way, whichever is most restrictive.
2. No building on a lot or parcel adjacent to a planned frontage road, right of way shall be closer than 175' from the centerline of US Hwy 24. In all other circumstances, no building on a lot or parcel shall be closer than 80' from the centerline of US Hwy 24.
3. No building shall be closer than 50' from the centerline of any other public right-of-way.
4. No building shall be closer than 30' from any side or rear property line.
5. Buildings footprint areas shall not exceed 70% of the lot or parcel area.
6. Accessory structures, excluding Accessory Buildings, shall be allowed within any rear or side setback but may not be any closer than 10' to any rear or side property line.

F. Miscellaneous Requirements

1. Headwalls for drainage pipes under driveway entrances shall be designed and constructed with a slope and flare.
2. All public utilities, with the exception of major electric transmission lines responsible for transporting power through the area rather than to the area shall be installed underground.
3. Every lot/parcel shall provide an individual storm water detention pond or be connected to an existing storm water detention pond. If a storm water district exists, compliance with the requirements and fees of such a district shall be required.

4. No on-site, non-public, individual storage tanks in excess of 500 gallons shall be allowed, including, but not limited to, those used for the storage of gasoline, diesel fuel, oil, water, or propane gas. This maximum volume limitation may be waived upon receipt by the Staff of a letter of approval from the Board of Commissioners of White County. All above ground tanks shall be enclosed by an opaque fence and gate and locked at all times other than for access or service. All such storage tanks shall fully comply with any and all applicable local, state and federal statutes and administrative regulations.
5. No outside storage, unless provided for elsewhere in this Section, is permissible. This requirement may be waived upon receipt by the Staff of a letter of approval for specific outside storage activities from the Board of Commissioners of White County.
6. In addition to the screening requirements of Chapter 9, Subsection 9.3.8, as amended from time to time, all refuse and recycling area screening must be architecturally compatible with the principal building.
7. Parking lots areas for employees, vendors, freight vehicles or company vehicles shall be exempt from any tree island requirement otherwise provided for in this ordinance.
8. Parking lot areas for visitors must meet the tree island requirements as provided for in this ordinance.
9. All signs are subject to the standards, restrictions and limitations provided for in Chapter 10 of this Ordinance as amended from time to time. Wall signage is subject to the following additional restrictions:
 - a. For any elevation facing a public right-of-way, the sign(s) must be incorporated into the building façade;
 - b. Wall signs cannot be painted directly onto the building elevation;
 - c. All signage, unless designated as “exempt” in Chapter 10, must be consistent in style and scale with its associated structure;
 - d. Individually illuminated channel letters are preferred; and,
 - e. Back-lit, internally illuminated box signs are not allowed.

Note: Infrastructure associated with connecting a facility’s operations to the railroad line running alongside Mid America Commerce Park properties are exempt from zoning developmental standards.

3.15 GENERAL PERFORMANCE STANDARDS

In the interests of protecting the public health, safety and welfare, and to lessen injury to property, all uses established or placed into operation after the effective date of this Ordinance shall comply with the following performance standards. No use shall exhibit obnoxious characteristics to the extent that it constitutes a public nuisance as further prescribed hereinafter. No use in existence on the effective date of this Ordinance shall be so altered or modified to conflict with these standards.

3.15.1 Authority

All uses shall comply with the performance standards established in this Chapter, unless any federal, state, county, or local ordinance, law or regulation establishes a more restrictive standard in which event the more restrictive standard shall apply.

3.15.2 Compliance

When tests by the Executive Director indicate a possible violation of these performance standards, the Executive Director shall require the property owner to obtain and bear the cost of the appropriate technical assistance to ascertain the exact amount of emissions of noxious effects at the lot lines of the property in questions. The results of the test or tests shall be presented to the Area Plan Commission in writing.

3.15.3 Enforcement

Enforcement of the performance standards shall be the duty of the Executive Director pursuant to Chapter 13, Enforcement.

3.15.4 Exceptions

The following exceptions to general performance standards, apply to:

Site preparation or construction, maintenance, repair, alteration, or improvement of buildings, structures, equipment, or other improvements on or within the lot lines.

The operation of motor vehicles or other facilities for the transportation of personnel, materials, or products;

Conditions beyond the control of the user such as fire, explosion, accident, failure, or breakdown;

Safety or emergency warning signals or alarms necessary for the protection of life, limb, or property;

3.15.5 General provisions

The following shall apply to all uses, unless otherwise provided for by this Ordinance.

Fire protection - Firefighting equipment and prevention measures acceptable to the local Fire Department shall be readily available and apparent when any activity involving the handling or storage of flammable or explosive materials is conducted.

Fire and explosion hazards - Materials that present potential fire and explosive hazards shall be transported, stored and used only in conformance with all applicable federal, state, or local ordinances and laws.

Toxic matter - The storage, handling, or transport of toxic substances shall comply with all federal, state, county and local laws and regulations regarding the storage, handling, and transport of toxic material. No use shall discharge across the boundaries of its lot toxic matter so as to endanger the public health, safety, or general welfare, or cause injury or damage to an abutting or adjoining property.

Electrical disturbance - No use shall cause electrical disturbance adversely affecting radio, television, or other equipment in the vicinity.

County Nuisance and Odor Ordinances; Indiana Nuisance Code – All uses, activities and developments shall be in compliance with the standards, limitations, restrictions and requirements of any County Nuisance and/or Odor Ordinance and are also subject to the Indiana State Nuisance Code, IC 32-30-6, as amended from time to time. In addition, all land uses, activities and developments are subject, but not limited to, the standards, regulations and requirements of Subsections A-F below. In any case where there is conflict between A-F below and the aforementioned Ordinances and/or Indiana State Code, the Ordinances and/or Indiana State Code shall rule.

- A. Poisonous and injurious fumes and gases - The emission of any gas or fumes across lot lines in such concentrations as to be detrimental to or endanger public health, safety, comfort, and welfare or which shall cause injury or damage to property or business is prohibited. The emission of toxic and/or injurious fumes and gases, from any source, shall not exceed ten (10) percent of the threshold limits set forth in the latest book of guidelines published by the American Conference of Governmental Industrial Hygienists (ACGIH) pertaining to Threshold Limit Values (TLV's) and Biological Exposure Indices (BEI's) for the workplace.
- B. Air pollution - No use shall discharge across the lot lines fly ash, dust, smoke, vapors, noxious, toxic or corrosive matter, or other air pollutants in such concentration as to be detrimental to health, animals, vegetation or property, or in conflict with public air quality standards established by State or Federal agencies.
- C. Smoke - The maximum amount of smoke emissions permitted shall be determined by the use of the Standard Ringleman Chart issued by the United States Bureau of Mines. No smoke darker than No. 2 shall be allowed.
- D. Heat and glare - No use shall produce heat or glare in such a manner as to create a hazard perceptible from any point beyond the lot lines.
- E. Water pollution - No use shall produce erosion or other pollutants in such quantity as to be detrimental to adjacent properties or in conflict with public water quality standards.
- F. Waste matter - No use shall accumulate within the lot or discharge beyond the lot lines any waste matter, whether liquid or solid, in conflict with applicable public health, safety and welfare standards and regulations.

3.16 SPECIAL EXCEPTION USE CRITERIA & REQUIREMENTS

The following standards and regulations are required criteria when a Special Exception Use Permit is required. These standards are to be applied by the Staff in cases where the use is a "permitted" use as provided for in Appendix A: Official Schedule of Uses.

3.16.1 Category 1: Adult Entertainment Business; Tattoo Parlor

A Category 1 use cannot be within five hundred (500) feet of any church, public, private or parochial school, library, public park, county courthouse, municipal building, licensed child care facility, museum, public swimming area or any residential zoning district as measured from the closest property line of the use to the nearest property line of the use described within this requirement.

All distances shall be measured in a straight line without regard to intervening structures or objects from the closest property line to each such use or application.

The minimum distance between any Category 1 use property line and another Category 1 use property line shall be one thousand (1,000) feet.

Should any Category 1 use be located in a multiple entity development, the exterior walls shall substitute for the property lines for that particular Category 1 business.

No Category 1 use shall be conducted in any manner that permits the observation of any material depicting, describing or relating matters or performances as defined by IC 35-49-2, as amended from time to time, by display, decorations, sign, show, window or other opening observable from any neighboring property or public right-of-way.

Each Category 1 use must meet all other ordinance requirements as provided for in the White County Indiana Zoning Ordinance and any other requirement designated by the Board of Zoning Appeals.

3.16.2 Category 2: Agricultural Industry; Agricultural Research Firm; Asphalt Plant (manufacturing); Bottled Gas Storage & Distribution Yard; Construction, Heavy Contractors; Ethanol or other similar Bio-Processing Plant; Explosives, Use or Storage; Hatchery, Commercial; Hazardous Waste Landfill/Facility; Incinerator; Industrial Waste Facility; Junkyard; Landfill; Recycling Facility; Scrap Metal Yard; Sewage Treatment Plant, Private; Slaughter House

Each Category 2 use must be located on a parcel of land at least three (3) acres in size with no more than a 3:1 ratio in parcel length to width or parcel width to length.

For a Junk Yard, Recycling Facility, Scrap Metal Yard or Solid Waste Transfer Facility use, operations shall be conducted entirely within enclosed buildings or an area bordered by opaque fence not less than 8 feet in height which bears no advertising and is constructed in such a manner that no outside storage or salvage operations shall be visible from an adjacent property or highway. The front yard fence requirement may be waived by the Area Board of Zoning Appeals should they deem the requirement unnecessary to preserve safety or aesthetic compatibility with any surrounding properties within one-quarter ($\frac{1}{4}$) mile from the nearest point of the front lot line measured in a straight line without regard to intervening structures or objects.

No processing operations (operations or activities performed in the making or treatment of a product) shall be conducted within three hundred (300) feet of any residential district.

There shall be a minimum of twenty (20) feet natural buffer between any property line and the fence location.

All distances shall be measured in a straight line without regard to intervening structures or objects from the closest property line to each such use or application.

Any signs or lighting permitted in conjunction with the use shall be appropriate to the location and in harmony with the general character of the properties in the area.

Special consideration shall be given to the size, design, location of these uses in relation to surrounding properties and reasonable assurances shall be provided that the use of these areas will not create noise, glare or other adverse effect on adjoining and nearby (within one (1) mile) properties.

The streets and roads serving the use shall handle any expected traffic and load increase with no more than minor traffic disruptions to adjoining or nearby (within one (1) mile) properties and no significant additional wear and tear on roadways.

Each Category 2 use must meet all other ordinance requirements as provided for in the White County Indiana Zoning Ordinance and any other requirement designated by the Board of Zoning Appeals.

3.16.3 **Category 3-A: Airport; Correctional/Penal Facility/Prison; Railroad Facilities**

Each Category 3-A use must be located on a parcel of land with no more than a three to one (3:1) ratio in parcel length to width or parcel width to length.

Minimum parcel sizes for each use will be as follows:

1. Airport – 20 Acres
2. Correctional/Penal Facility/Prison – 20 Acres
3. Railroad Facilities – As specified by Bulk Use Chart for applicable zoning district

All zoning district boundaries for any Category 3-A use must lay a minimum of one (1) mile or a distance established by the appropriate legislative body from any zoning district boundary in which any school, library, community center or religious institution sits. If a distance is applied which has been established by the appropriate legislative body, a resolution from that body must be provided to the Staff at the time of application for the special exception use permit.

Any proposed airport or airport expansion must be situated in such a manner as to not create any FAA airport regulation or zoning non-conformances.

Any Category 3-A use must submit site plans, permit applications, certifications and any other documents required to demonstrate compliance with all Federal, State and Local laws, statutes or regulations.

Each Category 3-A site must comply with any and all Federal, State and Local laws, statutes or regulations.

Any Category 3-A proposed district boundary line for a Category 3-A use, if located within one (1) mile of any municipality line, must obtain a resolution of approval authorized by the municipal legislative body prior and which must be submitted to the staff as part of their application for a Special Exception Use Permit.

Any signs or lighting permitted in conjunction with the use shall be appropriate to the location and in harmony with the general character of the properties in the area.

Special consideration shall be given to the size, design, location of these uses in relation to surrounding properties. The applicant shall provide documents certified by a qualified, registered, professional engineer that the intended use of these areas will not create noise, glare or other adverse effects on adjoining and nearby (within one (1) mile) properties.

The streets and roads serving the use shall handle any expected traffic and load increase with no more than minor traffic disruptions to adjoining or nearby (within one (1) mile) properties and no significant additional wear and tear on roadways.

All distances shall be measured in a straight line without regard to intervening structures or objects from the closest property line to each such use or application.

Each Category 3-A use must meet all other ordinance requirements as provided for in the White County Indiana Zoning Ordinance and any other requirement designated by the Board of Zoning Appeals.

3.16.4 Category 3-B: Heliport

All zoning district boundaries for any Category 3-B use must lie a minimum of one (1) mile from any zoning district boundary in which any school, library, community center or religious institution sits.

Each Category 3-B site must comply with any and all Federal, State or Local laws, statutes or regulations.

All distances shall be measured in a straight line without regard to intervening structures or objects from the closest property line to each such use or application.

Each Category 3-B business must meet all other ordinance requirements as provided for in the White County Indiana Zoning Ordinance and any other requirement designated by the Board of Zoning Appeals.

3.16.5 Category 4: Bed & Breakfast Establishment; Boarding House/Rooming House

The owner and operator of any Category 4 business shall live on the property.

No Category 4 business shall have no more than six (6) guest rooms and no more than twelve (12) occupants, beside the owner(s) and operator(s), staying at the establishment at any given time.

Any alterations made to the external appearance of any on-site structure shall not deviate from that of a residential nature.

All Category 4 establishments shall be limited to one non-illuminated, on-premise sign, no greater than eight (8) square feet.

Each Category 4 business must meet all other ordinance requirements as provided for in the White County Indiana Zoning Ordinance or any other requirement designated by the Board of Zoning Appeals.

Any Category 4 business abutting any differing zoning district must supply buffering along the perimeter of the rear and side property lines in the form of a fence compliant with Section 9.5 and minimum of five (5) feet tall or by sight obscuring vegetation.

No Category 4 business may be located within two hundred (200) feet of another Category 4 business measured in a direct line, closest property line to closest property line, without regard to intervening structures or objects.

Each Category 4 business use must provide a minimum one (1) parking space for each guest room plus two (2) for employees & owners if parking space requirements are not specified in the Parking Space Table 8.6 of the White County Indiana Zoning Ordinance.

Any signs or lighting permitted in conjunction with the use shall be appropriate to the location and in harmony with the general character of the properties in the area.

Special consideration shall be given to the size, design, location of these uses in relation to surrounding properties and reasonable assurances shall be provided that the use of these areas will not create noise, glare or other adverse effect on adjoining and nearby (within one (1) mile) properties.

The streets and roads serving the use shall handle any expected traffic and load increase with no more than minor traffic disruptions to adjoining or nearby (within one (1) mile) properties and no significant additional wear and tear on roadways.

All distances shall be measured in a straight line without regard to intervening structures or objects from the closest property line to each such use or application.

Each Category 4 business must meet all other ordinance requirements as provided for in the White County Indiana Zoning Ordinance and any other requirement designated by the Board of Zoning Appeals.

3.16.6 Category 5: Restaurant Drive-Thru; Retail Establishment (0-99,000 GSF)

Any Category 5 establishment which incorporates an outdoor shooting range may only be open to the public during the hours of 8:00 am to 8:00 pm.

Any part of a lot used for a Category 5 use, even if only on an occasional basis, must be a minimum of four hundred (400) feet from any dwelling structure, measured in a direct line from the nearest point of the Category 5 use to the nearest point of the dwelling structure.

Any Category 5 use which includes an accessory use of an outdoor shooting range must be one thousand two hundred fifty (1,250) feet from any dwelling structure, excluding any dwelling structure on the same lot, measured in a direct line from the nearest point of the Category 5 use to the nearest point of the dwelling structure.

Any signs or lighting permitted in conjunction with the use shall be appropriate to the location and in harmony with the general character of the properties in the area.

Special consideration shall be given to the size, design, location of these uses in relation to surrounding properties and reasonable assurances shall be provided that the use of these areas will not create noise, glare or other adverse effect on adjoining and nearby (within one (1) mile) properties.

The streets and roads serving the use shall handle any expected traffic and load increase with no more than minor traffic disruptions to adjoining or nearby (within one (1) mile) properties and no significant additional wear and tear on roadways.

All distances shall be measured in a straight line without regard to intervening structures or objects from the closest property line to each such use or application.

Each Category 5 business must meet all other ordinance requirements as provided for in the White County Indiana Zoning Ordinance and any other requirement designated by the Board of Zoning Appeals.

3.16.7 Category 6: Auction Arena or Sales Barn (For Livestock); Driving Range; Golf Course; Neighborhood Facility; Recreational Facility, Indoor; Recreational Facility, Outdoor, Commercial; Shooting Range Indoor; Shooting Range, Outdoor; Stable or Boarding, Commercial; Stadium, Coliseum, Athletic Field - Commercial; Theater, Outdoor

Any signs or lighting permitted in conjunction with the use shall be appropriate to the location and in harmony with the general character of the properties in the area.

Any Shooting Range operation shall be required to submit a design plan which meets the criteria for the range type proposed as provided in the NRA Range Resource Book and submit such plan as part of their Special Exception Use Permit application.

Any Shooting Range operation shall provide a safety plan as part of their Special Exception Use Permit application. This plan shall address, but not be limited to, the areas of Gun Handling Rules, General Range Rules, Specific Range Rules and Administrative Rules and Regulations using the Area Plan Shooting Range Safety handout as a guide to establishing a proper plan.

Special consideration shall be given to the size, design, location of these uses in relation to surrounding properties and reasonable assurances shall be provided that the use of these areas will not create noise, glare or other adverse effect on adjoining and nearby (within one (1) mile) properties.

In the case of a Neighborhood Facility, a resolution of support for the facility and the location must be obtained from the appropriate legislative body.

The streets and roads serving the use shall handle any expected traffic and load increase with no more than minor traffic disruptions to adjoining or nearby (within one (1) mile) properties and no significant additional wear and tear on roadways.

All distances shall be measured in a straight line without regard to intervening structures or objects from the closest property line to each such use or application.

Each Category 6 use must meet all other ordinance requirements as provided for in the White County Indiana Zoning Ordinance and any other requirement designated by the Board of Zoning Appeals.

3.16.8 Category 7: Boat Storage (Commercial); Bus Garage; Bus Station, Passenger; Truck Freight Terminal; Truck Stop; Truck Wash; Veterinary Clinic

Each Category 7 business must be located on a single parcel a minimum of two (2) Acres in size with at least two hundred (200) feet of road frontage.

There shall be no outside storage of disabled vehicles, boats or trailers, vehicles pending maintenance (unless staged in a specific area approved by the Area Board of Zoning Appeals) or merchandise such as, skids, tires, lubricants, parts, inventory

or any other items deemed more appropriately stored indoors as determined by the Staff.

Any signs or lighting permitted in conjunction with the use shall be appropriate to the location and in harmony with the general character of the properties in the area.

Special consideration shall be given to the size, design, location of these uses in relation to surrounding properties and reasonable assurances shall be provided that the use of these areas will not create noise, glare or other adverse effect on adjoining and nearby (within one (1) mile) properties.

The streets and roads serving the use shall handle any expected traffic and load increase with no more than minor traffic disruptions to adjoining or nearby (within one (1) mile) properties and no significant additional wear and tear on roadways.

All distances shall be measured in a straight line without regard to intervening structures or objects from the closest property line to each such use or application.

Each Category 7 use must meet all other ordinance requirements as provided for in the White County Indiana Zoning Ordinance and any other requirement designated by the Board of Zoning Appeals.

3.16.9 Category 8: Vacation Home (aka: Vacation Rental, Holiday Home, Holiday Apartment, Tourist Home (VRBO))/Cabins

Parking must comply with Chapter 8 of the White County Indiana Zoning Ordinance.

Vacation Home Rules and Regulations must be submitted to and approved by the Staff. Rules and regulations must meet the minimum requirements listed below and any other requirements established by the Staff.

1. All posted versions of Rules and Regulations must be in upper case, print lettering in legible form
2. All letters must be a minimum of one-quarter (1/4) inch tall
3. Rules and Regulations must be posted inside near (within three (3) feet) each ingress-egress door and on the outside near (within three (3) feet) main entrance door
4. Rules and Regulations shall provide for ensuring the safety of guests and neighbors and for preservation of neighborhood values. Rules and Regulations shall include, as a minimum, the following:
 - a. Phone contact numbers for police, fire, all utilities and maintenance contact plus a 24-hour contact number for property owner or manager
 - b. Maximum occupancy
 - c. Noise restrictions
 - d. Waste management
 - e. Lake safety
 - f. Trespassing

- g. Fishing
 - h. Outdoor fires or cooking
 - i. Yard Usage
 - j. Other, as required by Staff
5. Rules and Regulations shall include a diagram which makes determination of the property boundary lines easily identifiable and which includes delineation of the parking area including parking space layout

No Vacation Home principal or accessory building may be located within fifty (50) feet of any abutting residential district property line. However, any abutting neighbor may waive this requirement. Such waiver must be included as part of the applicant's application for Special Exception Use to the Area Board of Zoning Appeals. In such cases where a waiver is granted, setback requirements must be met consistent with those normally applied to the property requesting the Special Exception Use or a variance received from the Area Board of Zoning Appeals.

Maximum occupancy: Two (2) people per bedroom or sleeping room (a room where sleeping accommodations are made available) but at no time more than twelve (12) overnight guests

A smoke detector is required for each bedroom, for each room in which sleeping accommodations are available, for each kitchen and for each room in which an operating fireplace exists

A properly maintained fire extinguisher in a living or family room plus one (1) properly maintained fire extinguisher in the kitchen area or within ten (10) feet of the kitchen area perimeter

All solid waste and refuse shall be placed in appropriate refuse containers without any type of spillage outside said containers.

All solid waste containers shall prevent any unreasonable, noxious odors from escaping (unreasonable, noxious odor is an odor which can be detected from any neighboring property (one next to or across a street or alley) from the Vacation Home property

Prior to commencing Vacation Home rental use, the property owner or manager must provide to the Staff an approval certification from the sewage and water authority servicing the property. In cases where a septic serves as the sewer service, an approval from the County Health Department is required. In cases of a shared well, all property owners having rights to the well must provide a letter to the Staff expressing agreement that the well may be used to support a vacation home operation.

3.16.10 Category 9: Event Barns

These following standards and regulations must be met for Special Exception Use approval and are to be applied by the Staff in any case where an Event Barn is a permitted use by right:

- 1) Minimum parcel size: 5 acres;

- 2) Minimum road frontage: 500 feet; for a parcel with more than one road front, 500' of frontage is required for each abutting roadway;
- 3) The facility must provide a minimum driveway width of 24', maximum of 30', at the rights-of-way line.
- 4) Driveways must be located a minimum of 100' from any road intersection or driveway located on an abutting property.
- 5) The driveway construction from the rights-of-way line to the paved parking area must also be paved as required by Chapter 8: Parking and Loading of the White County Indiana Zoning Control Ordinance.
- 6) The facility must have either,
 - a) a valid septic permit for commercial activities from the White County Health Department or Indiana State Department of Health, whichever is applicable or
 - b) authorization to use portable toilet units in a quantity and under terms satisfactory to the White County Health Department.

There must be a public posting of emergency contact information in a manner approved by the Executive Director.

3.17 CFO AND CAFO ADDITIONAL DEVELOPMENTAL AND USE STANDARDS FOR ALL A-1 & I-2 DISTRICTS

IN THE INTERESTS OF PROVIDING THE APPROPRIATE PHYSICAL SEPARATION BETWEEN CFO/CAFO OPERATIONS AND RESIDENTIAL USES AND NON-RESIDENTIAL DISTRICTS WHILE ACCOMMODATING THE FUTURE NEEDS OF THESE ACTIVITIES, ALL CFO/CAFO USES PREVIOUSLY ESTABLISHED OR PLACED INTO OPERATION AFTER THIS DATE. THIS SECTION BECOMES EFFECTIVE AND SHALL COMPLY WITH THE ADDITIONAL STANDARDS PROVIDED FOR IN THIS SECTION. THESE STANDARDS ARE IN ADDITION TO ANY OTHER STANDARDS PROVIDED FOR IN THIS ORDINANCE.

- 3.17.1 Setbacks: For the purpose of satisfying setback requirements established by this Section, any building or structure used in conjunction with an existing Digester or CFO/CAFO in an A-1 or I-2 District, shall be allowed to expand or reconstruct facilities and/or operations as long as such expansion or reconstruction occurs no closer to setback points than those physically in place as of July 1, 2016 or as provided below, whichever are least restrictive.**

The setback requirements established by this Section shall not be applied to any new residential construction or rezoning occurring after July 1, 2016, excluding reconstruction on a site with existing residential use.

- 3.17.2 **A. The District cannot be located within one (1) mile of an incorporated municipality or the unincorporated town areas of Idaville and Buffalo, utilizing such boundary lines as provided for on the White County Official Zoning Map;**
- B. The District cannot be located within one and one-half (1 ½) miles from any Lake Shafer, Big Monon, Tippecanoe River or Lake Freeman shoreline boundary as provided for on the White County Official Zoning Map;**
- C. The District cannot be located within one thousand seven hundred sixty (1,760) feet from the property line of any parcel of land legally platted within a recorded subdivision and which subdivision has at least six (6) lots developed with residential dwelling units.**
- D. Those structures used in confined feeding operations, auction yards and digester operations shall have a setback of one thousand three hundred twenty (1,320) feet from any other non-agricultural district, residence or business, unless located on the same property.**
- 3.17.3 **IDEM: Confined Feeding Operations shall have Indiana Department of Environmental Management (IDEM) approval prior to issuance of an Improvement Location Permit or Building Permit. All major drainage system and water wells shall be in compliance with IDEM standards.**

3.18 3.18 ODOR CONTROL SYSTEMS AND STANDARDS

3.18.1 Persons Responsible/Liable, Authority, Scope and Exclusions & Exemptions

A. Purpose

This section is established in order to protect the public health, safety and general welfare of the community by requiring proactive steps be taken to manage odor and its potential ill effects. This section works to avoid the adverse environmental conditions created by the dispersion of non-desirable odors on the community from specific, high risk industries and business sectors.

B. Persons Liable

The property owner, operator and developer of the site have the duty of compliance with the requirements of this Section and any other requirements provided for in this Ordinance pertaining to Odor requirements and standards.

C. Authority

The Executive Director is hereby vested with the authority to review and approve or deny Odor Control Plans (OCP) when required. An initial OCP is required prior to approval of a Building Permit or Improvement Location Permit for any industry or sector included under Subsection 3.18.1 D "Scope" of this Chapter.

Where a conflict occurs between this Section and any other requirements of the White County Indiana Zoning Control Ordinance, this Section shall rule.

D. Scope

Effective January 1, 2019, all entities desiring to initiate or expand facilities or operations within the following industries or sectors are required to submit an OCP for consideration at the time of application for either an Improvement Location Permit (ILP) and/or Building Permit (BP). No ILP and/or BP shall be issued until such time as the Executive Director has approved an OCP associated with any ILP and/or BP application.

Industries or Sectors for which an approved OCP is required are as follows:

- 1) Animal Food Manufacturing (Sector)
- 2) Rendering Plant (Industry)
- 3) Asphalt Plant (Industry)
- 4) Ethanol Plant (Industry)
- 5) Bio-Processing Plant (Sector)
- 6) Slaughter House (Industry)
- 7) Agri Bio-Production (Industry/Sector)

3.18.2 OCP Submission Requirements

For purposes of this section, the term "Submission" refers to a completed Odor Control Plan which satisfies the OCP Master Guide available from the Staff. The OCP Master Guide establishes the minimum content of any Submission. The Submission shall also include any and all other documents or materials to be considered for achieving the objectives and requirements of odor management and control that are spelled out in this Ordinance. Any party required to submit an OCP must also supply any documents, information and/or certifications required by the Executive Director which, in the Director's opinion, are relevant to the OCP or Odor Management of the subject facility(ies).

3.18.3 Fees

For a submission to be considered complete and prior to review by the Staff, the OCP application fee provided for in the Official Fee Schedule must be paid to the White County Indiana Building and Planning Department.

3.18.4 Plan Compliance

Once approved, an OCP is considered compliant until such time as the complaint threshold spelled out in Subsection 3.18.5 is reached or at such time the controls, requirements, standards and processes called out in the OCP are violated.

3.18.5 Violations

Each Complaint Threshold reached and each control, requirement, standard or process of the OCP which the facility fails to properly maintain is considered a separate and unique civil zoning violation subject to the enforcement activities provided for in Chapter 13 Enforcement of this Ordinance.

3.18.6 Complaints

All complaints filed via mail, phone, in person or by electronic means shall be logged and tracked by the facility for monitoring purposes. All complaints shall be counted toward the Complaint Threshold tabulation excluding those where the party filing the complaint resides or operates more than two (2) miles away, as measured by closest property boundary of the complaining site to the closest boundary of the subject site or where said party does not provide their name, address and time & duration of the odor occurrence.

3.18.7 Complaint Threshold

The Complaint Threshold established for any entity subject to the requirement of an OCP is ten (10) independent complaints from at least five (5) different owners or tenants from different properties within any ninety (90) day rolling period.

Upon reaching the complaint threshold, the subject site shall be considered non-conforming and in violation of the White County Indiana Zoning Control Ordinance and will be subject to enforcement actions as provided for in Chapter 13: Enforcement. A report of non-conforming status shall cause the entity responsible for the non-conformance, along with the property owner(s), (if different) to immediately arrange for site testing by a qualified, independent third party, shall provide a formal, written review of the OCP with specific recommendations of changes proposed for the OCP to eliminate further threshold violations and a summary of facility odor complaints received by facility personnel for the twelve month period prior to the date the non-conforming notification issued by the Executive Director and the mitigation steps taken to address each complaint.

Site test results shall be supplied to the Area Plan Staff within ninety (90) days from the date of non-conforming notification along with the written review and summary required above.

Within thirty (30) days from receipt of the above information, the Staff will provide a written determination indicating approval, denial or conditional approval of the corrective actions taken or to be taken by the violator.

3.18.8 Responsibility – Each entity responsible for compliance to an OCP, is also responsible for the arrangements & costs related to ongoing monitoring of their odor management program as well as the arrangements and costs pertaining to a notice of violation from the Area Plan Commission Executive Director.

3.18.9 Standards – Odor measurement standards are based on a measurement of odor intensity at each property boundary line. All odor measuring shall be conducted by an inspector or firm qualified to conduct such testing. Utilization of a Field Olfactometer shall be the measuring device used to conduct the field testing. A Dilution to Threshold maximum level of 7 is hereby established as the required odor standard applicable to any entity required to submit an OCP. Alternative measuring devices and standards may only be utilized upon approval from the Area Board of Zoning Appeals.

3.18.10 Certification of Compliance - Each entity subject to an OCP must provide a Certification of Compliance within sixty (60) days from the date of issuance of the

Certificate of Occupancy (C/O). The Certification of Compliance will include, at a minimum, testing results for odor intensity levels at each property line. Should the entity require more than sixty (60) days to execute testing and to certify results, the entity shall advise, in writing to the Area Plan Executive Director, the number of additional days required to complete and certify this process. The extension period shall not exceed ninety (90) days without approval from the Area Board of Zoning Appeals. The subject entity shall bear all costs associated with testing and execution of a Certificate of Compliance.

3.18.11 Confirmation of Compliance Certificate – A Confirmation of Compliance Certificate shall be provided no later than two (2) years from the date of the original Certification of Compliance. This Confirmation of Compliance Certificate will reflect that the site and facility are in compliance with the OCP, as amended from time to time, in every respect and that the original Certification of Compliance results are still being met or exceeded. An additional Confirmation of Compliance Certificate shall be provided within every three (3) year period using the date of the most recent Confirmation of Compliance Certificate as the timeline trigger each Certificate requirement. This timeline may be waived or modified upon approval by the Area Board of Zoning Appeals. The subject entity shall bear all costs associated with testing and execution of a Confirmation of Compliance Certificate.

3.18.12 Existing Sites – Any facility or operation in a covered industry or sector as specifically provided for in Subsection 3.18.1 D of this Ordinance, and which was actively operating as of July 1, 2019 is exempted from the standards, requirements and regulations of Section 3.18 unless the operations of the facility are either abandoned or discontinued for a period of 365 consecutive days or more. In the case of a facility which does abandon or discontinue operational activity for the 365-day time period described above, Section 3.18 of this Ordinance must be met prior to re-establishing operational activity. Any expansion of an “existing site” which occurred after July 1, 2019 and which expansion area exceeds ten thousand (10,000) square feet will be required to submit an OCP and to demonstrate compliance to the threshold standard listed in Subsection 3.18.9 along with all other pertinent Subsections of Section 3.18 for the said expansion portion only. The qualified inspector or firm hired to conduct testing for the expansion should use industry “best practices” for establishing the odor allowance for the portion of operation which qualifies as an “existing site”.

Each plan shall be submitted to the Area Plan Staff for review and determination of acceptance. The Staff may approve, deny or approve with conditions any OCP submitted to it for review. In the case of denial, the Staff will provide the reasons for rejection to the submitted organization in writing within thirty (30) days after submission of a complete OCP. Any decision of the Staff may be appealed to the Area Board of Zoning Appeals by following the Appeal procedure of an administrative decision as provided for in this Ordinance.

Section 3.19: Broadband Project Application Procedure

The following procedure provides the process which an entity shall follow in order to obtain a Broadband Project Permit in White County. For purposes of this procedure and application process, a Broadband Project is defined as “The construction or deployment of wireless or wireless communications facilities to provide communications services as defined in IC 8-1-32.5-3, as amended from time to time”.

All definitions delineated in IC 5-28-28.5-8, as amended from time to time, are hereby incorporated into this procedure by reference and specific to this Section.

This procedure is applicable to both the incorporated and unincorporated areas of White County.

3.19-1: Submit a Broadband Application to the Area Plan Department (APD) for review.

3.19-2: The Application, including any required supporting documents, may be submitted in hard copy directly to the APD or submitted in electronic form under the APD’s application link on White County’s Official Web Page.

3.19-3: All applications shall be submitted on an Improvement Location Permit (ILP) application form. Any required supplemental documents shall be submitted in a form required by the ADP; although, any required supplemental document must have the ability to be submitted electronically.

3.19-4: The Department will review and approve or reject the application within 10 days from the date a properly executed application and any required supplemental documents are submitted to the APD. The APD will issue a written notification of application determination and, if rejected, the reasons for rejection.

3.19-5: The APD will issue a permit noting on the permit any required inspections.

3.19-6: The applicant or his/her representative must call-in to the APD to schedule each inspection.

3.19-7: Any required inspections will be conducted by an official of the ADP or by a representative assigned by the ADP and will be completed in a timely and expeditious manner after notification to the APD in the manner prescribed in Section 7.22-6.

3.19-8: This procedure shall not:

- A. Require an applicant to designate a final contractor to complete the project;
- B. Impose a fee to review an application or issue or Broadband Project fee;
- C. Impose a seasonal moratorium on the issuance of permits for a project; or,
- D. Discriminate among communications service providers or utilities with respect to any action described in this procedure or otherwise related to a Broadband Project, including granting access to public rights-of-way, infrastructure and poles, river and bridge crossings and any other physical assets owned or controlled by the County

CHAPTER 4 USE CLASSIFICATIONS AND PROVISIONS

4.0 PURPOSE AND INTENT

The purpose of this Chapter is to protect the health, safety and welfare of individuals as well as property values. Additionally, the standards in this Chapter are designed to preserve scarce natural resources, agricultural and sensitive environmental areas while providing for separate locations within the County for residential development and businesses and employment areas associated with economic development. In some cases, it is important to maintain and promote the separation of uses to limit incompatibility and negative impacts between uses. This Chapter is intended to establish the rules for the regulation of permitted, special exception, accessory, and temporary uses in each zoning district.

4.1 APPLICABILITY

The standards in this Chapter shall apply to each zoning district as specified.

4.2 EXPLANATION OF USE CLASSIFICATIONS

4.2.1 Official Schedule of Uses

Principal and accessory uses are permitted or prohibited in the zoning districts established by or under this Chapter, and as shown in Appendix A, Schedule of Uses. Appendix A shall determine whether or not a specific use is permitted, prohibited, or requires a special exception use in each of the zoning districts established by this Ordinance.

4.2.2 Permitted uses

A principal use may be authorized as either a permitted use or a special exception use. Permitted uses are those uses which are allowed without special permission from the Board of Zoning Appeals, provided that they comply with the provisions set forth in this Ordinance. Special exception uses are only permitted following a public hearing and approval by the Board of Zoning Appeals, as prescribed in Chapter 12, Administration, of this Ordinance.

4.2.3 Special exception uses

A special exception use is one which is generally compatible with other activities permitted within a given zoning district so long as the number, size, location and relationship to the surrounding area and site conditions are controlled. Therefore, the determination of special exception uses as appropriate shall be contingent on their meeting the standards prescribed by this Ordinance, the provisions of their respective zoning districts, and the weighing, in each case, of the public benefit and need against the local impact. All special exception uses for a parcel governed by this Ordinance shall hereby require an added level of review and approval (Refer to the special exception use permit review and approval process prescribed by Chapter 12,

Administration) to ensure compatibility with the residential, non-residential, and/or agricultural uses allowed in a given district.

4.2.4 **Accessory uses and structures**

Refer to Section 4.3 below for Accessory Use qualification and clarifications and Chapter 14 for the Accessory Structure definition.

4.2.5 **Temporary uses and structures**

Refer to Section 4.40 below.

4.2.6 **Non-conforming uses, structures, and uses and structures in combination**

Refer to Section 4.50 below.

4.3 **ACCESSORY USE PROVISIONS**

4.3.1 **General provisions**

Accessory uses shall be permitted in all zoning districts in accordance with the provisions of this Section and as provided elsewhere in this Ordinance. Accessory uses are intended to be:

- A. Incidental and subordinate to, and commonly associated with the operation of the principal use of the lot;
- B. Operated and maintained under the same ownership and on the same lot as the principal use;
- C. On a secondary lot owned by the same entity and within three hundred sixty (360) feet of the lot with the principal use; or,
- D. Located on a lot which, by deed or covenant, is designated for accessory use and structures only.

4.3.2 **Domesticated animals**

No more than five (5) domestic animals are permitted on any lot, provided that the keeping of said animals is not for profit and not construed as a kennel. Six (6) or more domestic animals shall be considered "Raising or Breeding of Non-Farm Fowl and Animals" and shall be subject to the regulations of such a use.

4.3.3 **Exotic animals**

There shall be no exotic animals permitted in any residential district unless the animal is small enough to be housed, at all times, in the primary residential structure.

4.3.4 **Livestock animals & Bees**

Livestock animals shall only be allowed within a "RR", "A-1" or "A-2 district except as provided for in this Subsection or as specifically allowed elsewhere in this Ordinance.

A. Bees

Under certain circumstances, any property owner is allowed to conduct beekeeping operations under the rules, regulations and requirements provided below: All such operations must comply with standards established by the Apiary Inspectors of America. Any conflicts between the standards listed below and those established by the Apiary Inspectors of America, the Apiary Inspectors of America standards shall prevail.

1. Exemption: Any naturally created beehive is exempt from the rules, regulations and requirements of this Ordinance Section (4.3.4). Any beekeeping operations located in an A-1 or A-2 zoning district in conjunction with an agricultural operation, whether operated as a principal or accessory use, is exempt from the rules, regulations and requirements of this Ordinance Subsection (4.3.4).
2. All beekeeping operations are subject to standards adopted by the Apiary Inspectors of America.
3. Bee, Domestic Honey: (For the purpose of this section, the term “bee” only refers to the Domestic Honey Bee as defined in Chapter 14 of this Ordinance.)
 - a. In any zoning district, a bee apiary may be kept as long as the following guidelines are adhered to:
 - 1) Lot size and colony density: parcels up to seven thousand five hundred (7,500) square feet of lot area qualify the parcel to accommodate one (1) apiary; one additional apiary may be harbored for each additional five thousand (5,000) square feet of lot size above the first seven thousand five hundred (7,500) square feet of lot size. The maximum number of apiaries allowed, regardless of lot size, is four (4);
 - 2) Setbacks: No apiary shall be allowed to be closer than ten (10) feet to any property line, right-of-way or public sidewalk. No apiary may be placed within a front yard or rear yard setback;
 - 3) Flyway barriers: A solid fence or wall of vegetation with a height of between five (5) and six (6) feet (inclusive), must be placed a minimum of five (5) feet and maximum of seven (7) feet from the front entrance of the apiary, extending outward between three and one-half (3 ½) and four and one-half (4 ½) feet in both directions from the apiary centerline;
 - 4) A clean water source must be available within the confines of the parcel, designed in a manner conducive to bee usage and which prevents any significant number of bees from using a water source on an abutting property;
 - 5) Any apiary identified as a nuisance, determined by aggressive behavior of any bees servicing the beehive or bees swarming on neighboring properties, must have its use immediately terminated on the parcel of land.
 - 6) A property owner must register all apiaries with the White County Area Plan Staff. A registration fee shall be required before establishment of any apiaries as provided for in the Area Plan Official Fee Schedule;

4. 4-H Animals

- a. Any animal, fish, fowl or insect bred or raised in conjunction with a 4-H project is permitted in any A-1, A-2 or RR District and is exempt from the limitations, restrictions and requirements of Subsection “b” and “c” below.
- b. When related to a 4-H or school project, any resident in an L-1, R-1, R-2, R-3 or R-4 district is allowed to habitat rabbits, ducks or chickens subject to the following restrictions:
 - 1) No more than two (2) of any animal per project is permitted on site at any given time;
 - 2) Upon request by the Executive Director, Area Plan Commission or Area Board of Zoning Appeals, a property owner or project participant must provide written certification from a 4-H or school official identifying the animal(s) as part of 4-H or school project; such certification must include the project’s completion date;
 - 3) All animals must be disposed of in a humane manner within thirty (30) days from the project’s completion date;
 - 4) All 4-H/school animal project sites must take all reasonable steps to prevent the site from creating a neighborhood nuisance; and,
 - 5) All animals must be restrained in a fashion which keeps them a minimum of six (6) feet from any side or rear property line; no containment area may encroach a front setback.
- c. Other
 - 1) When related to a 4-H project, a resident is allowed to habitat any animal, fish, fowl or insect, which is kept inside a building or structure at all times and confined to a cage, tank or pen.
 - 2) Any animal, fish, fowl or insect covered under this Ordinance subsection may not exceed twenty (25) pounds at adult weight.

4.3.5 **Swimming pools**

All swimming pools shall be in compliance with IAC 20-4-27.

4.3.6 **Management offices**

Management offices in multi-family dwellings and other facilities normally associated with tenants' convenience, such as vending machines and washing machines are permitted, provided there is no exterior display of such sale of goods.

4.3.7 **Use, storage or parking of recreational vehicles**

No recreational vehicle shall be maintained in White County as a permanent office or residence, nor shall a recreational vehicle be permanently affixed to a property unless it is properly located within an approved campground, approved manufactured home park or AED district.

“Permanently Affixed” shall be defined as when:

- a) electricity is hardwired to the vehicle; or
- b) the vehicle is directly attached to a well or septic; or
- c) the vehicle is secured to a concrete foundation

A recreational vehicle may be stored or parked on any property governed by this Ordinance, provided that it does not constitute a nuisance or fire hazard and provided the following conditions are also met:

A. In any district, the wheels or any similar transporting devices of any recreational vehicle shall not be removed except for repairs, nor shall such vehicle be otherwise permanently fixed to the ground in a manner that would prevent ready removal of said structure.

B. RV Parking and Storing in a Residential or A-1 district:

1. In any residential or A-1 district a recreational vehicle, not in use, may be stored or parked behind or along side a principal or accessory structure or in any driveway or designated parking area. In no instance shall any part of any such vehicle be located closer than four (4) feet to any property line.-

2. Not more than one (1) personal Recreational Vehicle and one visiting Recreational Vehicle may be parked or stored in the open at any one time. Visiting RV parking and storage is restricted to no more than fourteen (14) consecutive days or forty-five (45) days in any three hundred sixty-five (365) day period. There is no limitation to the parking or storage of a personally owned Recreational Vehicle. There is no limitation to the parking or storage of any RV as long as the RV is fully enclosed within a structure.

C. RV "Use" in a Residential or A-1 district:

1. On any lot within any incorporated municipality or within the defined limits of the Town of Buffalo or Idaville, and which is assigned with a residential or A-1 district designation, an RV is restricted to parking and storage only. Temporary, recreational use may be allowed but only with written authorization of the Executive Director and for a period not to exceed forty-five (45) days in any three hundred sixty-five (365) day rolling period.

2. On any lot in an unincorporated area of White County, excluding the town limits of Idaville and Buffalo, and which lot lies within a residential or A-1 zoning district, no more than one (1) personally owned recreational vehicle and one (1) visiting recreational vehicle shall be permitted to be used at any one time, This restriction does not apply to an approved campground or manufactured home park for which there are no restrictions. Use is restricted to the property owners, property owner family members or personal friends. Rental of the unit for any duration, non-recreational use and residential use is strictly prohibited. For purposes of this section, a recreational vehicle shall be considered to be in "use" if the recreational vehicle is connected to gas, water, electric or sewer. Any Recreational Vehicle in use must be located in the rear yard, side yard, a designated parking area or driveway. On a vacant lot, the unit can be located anywhere as long as it is no closer than ten (10) feet to the front property line or right-of-way line; whichever is most restrictive and no closer than four (4) feet to any side or rear property line. Visiting recreational vehicles shall be limited to one (1) and shall only be permitted for a maximum of fourteen (14) consecutive days, not to exceed twenty-eight (28) days in any three hundred sixty-five (365) day rolling period.

- D. In a business or industrial district, there shall be no limit to the number of recreational vehicles stored outdoors.
- E. At no time shall a parked or stored recreational vehicle in a business or industrial district be occupied or used for living, sleeping or housekeeping purposes.
- F. Notwithstanding the provisions of this Section, recreational vehicles may be parked anywhere on a residential premises for loading or unloading purposes, provided that it is not longer than twenty-four (24) hours at one time, and no more than twice per week, regardless of the number of hours spent parked on the premises.

4.4 TEMPORARY USES

Temporary Uses may be allowed in accordance with the requirements of this Chapter. Refer to Appendix A, Official Schedule of Uses, for a list of temporary uses permitted by district.

4.4.1 General provisions

- A. The duration of a temporary use permit shall be as prescribed below. An extension of any temporary use permit may be requested.
- B. Temporary Uses and/or structures shall take place or be located in a manner so as not to create a nuisance or safety hazard as determined by the Executive Director.

C. Allowed Temporary Use Provisions – Temporary Use Permit Required

The following uses are allowed subject to the established regulations:

1. Professional or Business office. Maximum time permitted: 18 months.
2. Portable concrete or cement batching plant, such use must be both incidental and necessary to construction. Maximum time permitted: 18 months.
3. Construction yard or sawmill, such use must be both incidental and necessary to construction. Maximum time permitted: 18 months.
4. Parking lot designated for a special event. Maximum time permitted: 30 days.
5. Bazaars, carnivals, circus, entertainment facility (commercial), outdoor theater, mechanical rides, petting zoo, sporting events (for profit) and similar uses, except as excluded in Section 4.4.1 D. Maximum time permitted: 30 days.
6. Flea market. Maximum time permitted: 10 days.
7. Placement of a mobile home or manufactured home as an on-site office during construction and development or for other non-construction use. Permit requirement only applies to those requests which are located outside of a local municipality, but within the jurisdiction of the White County Area Plan Commission. Maximum time permitted: 18 months.
8. A mobile or manufactured home or may be moved onto a lot and be used as a temporary residence per Section 3.4.1 of this Ordinance.

9. A recreational vehicle may be moved onto a lot and used as temporary construction housing, but may not be permanently affixed as defined in Section 4.3.7. Maximum time permitted: 18 months.
 10. Portable Storage in a non-residential zoning district. Maximum time permitted: 30 days (for residential zoning districts refer to Chapter 8, Section 8.6.3 of this Ordinance).
 11. Other similar temporary uses approved by the Executive Director and attached with such time period, conditions and safeguards as the Executive Director may deem necessary.
- D. Allowed Temporary Use Provision – Temporary Use Permit Not Required
1. Municipality, Town or County sponsored or approved festival or event.
 2. Church, school, not-for-profit or charitable organization bazaar, bake sale, garage or yard sale, retail sales or similar use. Maximum time permitted: 7 days per event.
 3. Christmas tree sales and agricultural roadside stands.
 4. Portable agricultural product sales (from truck, cart, trailer or another portable vehicle).
 5. Auction. Maximum time permitted: 3 days per auction.
- E. A Temporary Use Permit may be rescinded should the use and/or structure result in a safety hazard or not be kept in a well-maintained condition.
- F. Temporary uses excluded from this requirement:
1. Tent use
 2. On-premise retail structures utilized by a retail establishment

4.4.2 Standards

- A. Adequate access and off-street parking facilities shall be provided for each temporary use. No such access or off-street parking shall interfere with traffic movement on adjacent streets.
- B. No public address systems or other noise producing devices associated with a temporary use shall be permitted in a residential district.
- C. Any flood lights or other lighting associated with the temporary use shall be directed upon the premises and shall not adversely impact adjacent properties.
- D. No banners, pennants or unnecessary signs associated with a temporary use shall be permitted in any residential district.
- E. The lot shall be put in clean condition devoid of temporary use remnants upon expiration of the temporary use permit.

4.5 NONCONFORMING USES AND STRUCTURES

Within the districts established by this Ordinance, including any amendments hereto, there may exist lots, uses, or structures which were lawful before the effective date of the ordinance, but which would be prohibited, regulated or restricted under the terms of this Ordinance. It is the intent of this Section to allow all non-agricultural nonconforming lots, uses, or structures to continue until they are removed, but not to encourage their survival. Nothing in this Section shall be deemed to prevent the strengthening, or restoring to a safe condition, any building or part thereof which has been declared to be unsafe by any official charged with protecting the public safety. The existence of nonconforming lots, uses and structures is not to be used as grounds for adding similar lots, uses or structures which would otherwise be prohibited. It is further the intent of this Ordinance that no nonconforming use or structure shall be enlarged upon, expanded or extended, nor be used as grounds for adding other structures or uses which are prohibited elsewhere in the same district. All nonconforming situations shall be governed by this Section.

4.5.1 General provisions

A. Illegal nonconforming uses

Illegal nonconforming uses existing at the time this Ordinance is enacted shall not be validated by virtue of its enactment.

B. Incompatibility of nonconforming uses

Nonconforming uses are declared by this Ordinance to be incompatible with permitted uses in the districts in which the use is located. With the exception of legally nonconforming agricultural uses and structures, a nonconforming use of a structure and land in combination shall not be extended or enlarged after passage of this Ordinance by attachment on a building or premises of additional signs intended to be seen from off the premises, or by the addition of other uses of a nature which would be generally prohibited in the district in which the use is located.

C. Avoidance of undue hardship

To avoid undue hardship, nothing in this Ordinance shall require any change in the plans for the construction or designated use of a building for which a Building Permit or an Improvement Location Permit, provided that the permit was issued prior to the effective date of adoption of this Ordinance, as amended from time to time, and upon which actual construction has begun. Actual construction is hereby defined as work done which is beyond the preparation stage and into that stage where the changes or additions are made permanent. Where demolition or removal of an existing building has been substantially begun preparatory work shall be carried on diligently.

D. Consistent with IC 36-7-4-616, an agricultural use of land that constitutes an agricultural nonconforming use may be changed to another agricultural use of land without losing agricultural nonconforming use status. In addition, an agricultural nonconforming use shall not be restricted or required to obtain a variance or special exception so long as an agricultural nonconforming use has been maintained for three (3) years in a five (5) year period.

E. Repairs and maintenance

Legally nonconforming agricultural uses excluded, work may be done on any nonconforming structure or portion of a structure containing a nonconforming use, in any period of twelve (12) consecutive months on ordinary repairs, or on repair or replacement of non-bearing walls, fixtures, wiring or plumbing, provided that the cubic content existing when it became nonconforming shall not be increased. Nothing in this Chapter shall be deemed to prevent the strengthening or restoring to a safe condition of any building or part thereof declared to be unsafe by any official charged with protecting the public safety, upon order of the official.

F. Unsafe Buildings

If any nonconforming structure or portion of a structure containing a nonconforming use becomes physically unsafe or unlawful by reason of physical condition, it shall not thereafter be restored, repaired or rebuilt except in conformity with the regulations of the district in which it is located.

4.5.2 Single nonconforming lots of record

A nonconforming lot is a lot which does not meet the minimum requirements in Appendix B for lot size and lot width, and which otherwise lawfully existed at the time those minimum requirements became effective.

In any district in which single-family dwellings are permitted, a single-family dwelling and customary accessory building(s) may be erected on a nonconforming lot if the legally created lot was either recorded in separate ownership or included in a recorded subdivision on or before August 4, 2008, the effective date of this ordinance; provided, however, that the single-family dwelling and its accessory building(s) meet all other requirements of this ordinance, except for lot size and lot width, including, but in no way limited to, the setback requirements in Appendix B.

A nonconforming lot changed to a conforming lot shall never be changed back to a nonconforming lot.

4.5.3 Nonconforming lots of record in combination

If two (2) or more lots or a combination of lots and portions of lots with continuous frontage in single ownership, and if all or part of the lots containing no structures do not meet the requirements established for lot width and area, at the time of adoption of this Ordinance as amended from time-to-time, the lands involved shall be considered to be an undivided parcel for the purposes of this Ordinance. No portion of the parcel shall be used or sold in a manner which diminishes compliance with the lot width and area requirements established by this Ordinance, nor shall any division of a parcel be made which creates a lot with width or area below the requirements stated in this Ordinance.

4.5.4 Nonconforming uses of land

Where, at the time of adoption of this Ordinance as amended from time-to-time, a lawful use of land exists which would not be permitted by the regulations imposed by this Ordinance, the use may be continued so long as it remains otherwise lawful. Said legally nonconforming use shall be subject to the following provisions:

- A. With the exception of a legally nonconforming agricultural use, no nonconforming use shall be enlarged or increased, nor extended to occupy a greater area of land than was occupied at the effective date of adoption or amendment of this Ordinance.

- B. With the exception of a legally nonconforming agricultural use, no nonconforming use shall be moved in whole or in part to any portion of the lot or parcel other than that occupied by the use on the effective date of adoption or amendment of this Ordinance.
- C. With the exception of a legally nonconforming agricultural use, any nonconforming use of land that is discontinued or abandoned for more than one (1) year (except when government action impedes access to the premises), any subsequent use of the land shall conform to the applicable regulations of this Ordinance.

4.5.5 Nonconforming structures

Where a lawful structure exists on the effective date of adoption or amendment of this Ordinance which could no longer be built under the terms of this Ordinance, the structure may be continued so long as it remains otherwise lawful. Said legally nonconforming structure shall be subject to the following provisions:

- A. With the exception of a legally nonconforming agricultural structure, no nonconforming structure may be enlarged or altered in a way which increases its nonconformity. However, any legally nonconforming structure or portion thereof may be altered to decrease its nonconformity.
- B. No nonconforming structure or nonconforming portion of the structure having been destroyed or altered by any means to the extent of more than fifty (50) percent of the appraised value of the building as it was prior to the damage or alteration, shall be reconstructed except in conformity with the provisions of this Ordinance. In the case of a residential nonconforming structure in a business district, the structure may be reconstructed as a residential structure provided that the new structure is of the same size and dimension as the residential structure being replaced.
- C. Any legally nonconforming structure moved for any reason for any distance shall thereafter conform to the regulations for the district to which it is relocated.

4.5.6 Nonconforming uses of structures or structures and land in combination

Where legal nonconforming use status applies to a structure and land in combination, an intentional removal or alteration of the structure or its use, which made the structure or use a nonconforming structure or use shall also eliminate the legal nonconforming status of the land. Legally nonconforming uses located in structures specifically constructed or modified to suit only such use are exempt from this provision and may be resumed if the structure has not been intentionally altered to serve other uses, used to house a permitted use, or used to house another nonconforming use.

A legal nonconforming use of structure and/or land in an I-3 district shall preserve its previously legal status and all rights and privileges granted by this ordinance in common with any other legal conforming use of structure and/or land.

4.5.7 Nonconforming districts

At the time of adoption of this Ordinance, as amended from time to time, the following zoning districts shall no longer be in existence. Unless otherwise noted, property zoned under these districts will continue to be zoned as such until such time as the property is rezoned to a conforming district. These nonconforming districts, including their restrictions and permitted uses include:

A. F-1 Flood Plain District

The F-1 District was provided to protect areas that are prone to flooding. The Conservation and Flood Plain Overlay District, including the permitted uses and development standards for a C-1 District set forth in Appendices A and B respectively, is the most similar to the former F-1 District. Under this Ordinance, permitted uses in F-1 Flood District will be replaced by uses permitted, either by right or special exception, in a C-1 District, as prescribed by Appendix A, Official Schedule of Uses.

B. R-5 Rural One and Two-Family Residential District

The R-5 District was provided for the development of one and two-family residential dwellings. The L-1 Lake District and the R-2 Single and Two-Family Residential District, including the development standards and permitted uses for these Districts set forth in Appendices A and B respectively, is the most similar to the former R-5 District. Under this Ordinance, permitted uses in the R-5 District will be replaced with uses permitted, either by right or by special exception, in an L-1 District, as prescribed by Appendix A, Official Schedule of Uses, if the lot abuts a lake or river area. For lots that do not abut a lake or river area, the uses permitted in the R-5 District will be replaced with uses permitted, either by right or by special exception, in an R-2 District, as prescribed by Appendix A, Official Schedule of Uses.

C. Rural Multi-Family Residential District

The R-6 District was provided for the development of multi-family residences in rural areas. The R-4 Mobile Home and Manufactured Home Park Residential District, including the development standards and permitted uses for the R-4 District set forth in Appendices A and B respectively, is the most similar to the former R-6 District. Under this Ordinance, permitted uses in the R-6 District will be replaced with uses permitted, either by right or by special exception, in an R-4 Mobile Home and Manufactured Home Park Residential District as prescribed by Appendix A, Official Schedule of Uses.

4.5.8 **Nonconforming manufactured and mobile homes**

This provision shall apply to manufactured homes and mobile homes located within White County, outside of municipal jurisdiction. Any manufactured home or mobile home located within a municipality shall be subject to the regulations of said municipality.

Manufactured homes and mobile homes are designed to be movable rather than fixed structures. Therefore, when a manufactured home or mobile home is a nonconforming use, the requirements of this section apply, rather than those of 4.5.1, 4.5.4, 4.5.5, and 4.5.6.

A. Nonconforming manufactured homes and mobile homes permitted to remain

Nonconforming manufactured homes and nonconforming mobile homes are ones which are not permitted in Appendix A, Schedule of Uses, to be located in the zone in which it is in fact located, and which otherwise lawfully existed at the time the applicable portion of Appendix A became effective. An otherwise lawful manufactured home or mobile home made a nonconforming manufactured home or mobile home by this Ordinance or an amendment to it, may be continued under each of the following terms and conditions:

1. The dimensions and size of the manufactured home or mobile home are not increased beyond what they were at the time this Ordinance or its amendment became effective and the footprint for the manufactured home or mobile home is not changed; provided, however, that the footprint of the manufactured home or mobile home may be changed and/or the dimensions and size of the manufactured home or mobile home may be increased beyond what they were at the time this Ordinance or its amendment became effective if the standards for setbacks, maximum lot coverage, and maximum structure height set forth in Appendix B for the particular zone in which the manufactured home or mobile home is located can be met.
2. No additional structure serving the nonconforming manufactured home or nonconforming mobile home is erected; provided, however, that a permitted accessory structure may be erected if the standards for setbacks, maximum lot coverage, and maximum structure height for principal structures and accessory structures set forth in Appendix B for the particular zone in which the manufactured home or mobile home is located can be met.
3. If the nonconforming use is discontinued for a period of twelve (12) months or more, the legally nonconforming mobile home status expires, and any subsequent use of that property shall conform to the requirements of the Ordinance including, but in no way limited to, setbacks, lot width, lot size, and Appendix A.
4. If the nonconforming manufactured home or nonconforming mobile home is substantially damaged or destroyed by any means to the extent that repairs or replacement would equal or exceed fifty percent (50%) of the market value of that manufactured home or mobile home, the nonconforming manufactured home or nonconforming mobile home may be replaced in accordance with Section 4.5.8(B) below provided that substantially damaged or destroyed nonconforming manufactured home or nonconforming mobile home is replaced within one (1) year of the date substantial damage or destruction is incurred. If replacement is not made within that time frame, the legally nonconforming manufactured home or mobile home status shall expire, and any subsequent use of the property shall conform to the requirements of the Ordinance including, but in no way limited to, setbacks, lot width, lot size, and Appendix A.
5. A nonconforming manufactured home or nonconforming mobile home changed to a conforming or permitted use shall never be changed back to a nonconforming manufactured home or nonconforming mobile home.
6. A nonconforming manufactured home or nonconforming mobile home shall not be replaced by any other kind of nonconforming use.

B. Replacement of nonconforming manufactured home or mobile home

A nonconforming manufactured home or nonconforming mobile home may be replaced with a Type I or Type II manufactured home or mobile home provided that the standards set forth in section 3.3 of the Ordinance and 4.5.8 (A) above are met, and the manufactured home or mobile home replaced is removed from the subject property within thirty (30) days of its replacement.

4.5.9 Nonconforming decks – lake properties

Any deck constructed prior to March 8, 2010, shall be permitted “as built” with regards to front, side and rear yard setbacks. Nothing in this Ordinance shall conflict with this stipulation.

CHAPTER 5 PLANNED UNIT DEVELOPMENT

5.0 PURPOSE AND INTENT

5.0.1 Purpose

It is the expectation of the County and participating municipalities that rezoning a property or properties to a Planned Unit Development (PUD) District will result in higher quality developments than would otherwise be required of a development in the existing zoning district(s). More specifically, the purposes of a PUD are to:

- A. Encourage a more creative approach in land and building site planning.
- B. Promote variety in the physical development pattern of the community; including mixed-use development.
- C. Use design to provide compatibility between areas of different land uses and development intensities within the PUD.
- D. Enhance the appearance of developments by conserving areas of natural beauty and natural open space.
- E. Encourage renewal of older areas where new development and restoration and rehabilitation are needed to revitalize the areas.
- F. Promote architecture that complements the surrounding areas.
- G. Permit special consideration of property with unique features, such as historical significance, unusual topography, landscape amenities, and size and shape.
- H. Simplify processing of development proposals for developers and the appropriate legislative body by providing for concurrent review of land use, subdivisions, public improvements, and siting considerations.
- I. Encourage developments that exceed the development standards of the previous zoning district to create a high quality development.

5.0.2 Intent

The intent of the Planned Unit Development (PUD) is to provide a means of achieving innovative and creative design, and flexibility of development through an alternative zoning procedure when sufficiently justified under the provisions of this Chapter. Planned Unit Developments are intended to encourage a higher quality of design aesthetic and include more amenities while accommodating development with mixed or varied uses. The most desirable site may be unusual in their topography or unique in their setting. This may include land which exhibits difficult or costly development problems. A PUD may be developed with a variety of residential types and non-residential uses. A PUD may contain both individual building sites and common property which are planned and developed as a unit. The end result shall fulfill the objectives of the comprehensive plan and other planning policies of the County and participating municipalities while departing from the application of the district regulations. It is not

intended that the appropriate legislative body automatically grant the concept plan of a development proposed by a petitioner. The Area Plan Commission shall approve only such plans of a development that are consistent with the public benefits resulting from planned developments. Therefore, the appropriate legislative body may require as a condition of approval and subsequent amendment of the zoning map, conditions, limitations or design factors which will promote proper development of a planned unit development. The Area Plan Commission shall discourage the use of a PUD as a means of circumventing the rezoning/subdivision process or to avoid the standards and requirements of this ordinance or the Subdivision Control Ordinance.

5.1 REZONING TO A PUD

A Planned Unit Development (PUD) may be granted as a rezone in any zoning district by the appropriate legislative body, should said body determine that the Planned Unit Development is in the best interest of the community, and that it complies with the intent of the standards established in this Ordinance. The Area Plan Commission and appropriate legislative body may require conditions of approval or design considerations that will promote proper development or benefit to the community.

5.2 REQUIREMENTS FOR A PUD

5.2.1 Ownership

The area designated on the PUD map must be a tract of land under single ownership or demonstrated control at the time of application. Single control of property under multiple ownerships may be accomplished through the use of enforceable covenants and commitments, which run to the benefit of the Area Plan Commission.

5.2.2 Preliminary PUD plan

The Preliminary Plan shall indicate the land use, development standards, and other applicable specifications of this Ordinance, which shall govern the PUD. If the Preliminary Plan does not address specific land use, development standards or other specification of this Ordinance (e.g. parking, landscaping, lighting, etc.), the applicable standard or regulation of the previous zoning district shall apply. The location of a PUD shall be designated on the Zoning Map and adopted pursuant to this Chapter. Improvements made to the proposed site prior to Preliminary PUD approval shall constitute a violation of the White County Zoning Ordinance.

5.2.3 Final PUD plan

The Final Plan shall show the location of all improvements.

5.2.4 Compliance with this Ordinance

The Preliminary Plan and Final Plan must comply with all required improvements, construction standards, design standards and all other engineering standards contained within this Ordinance and other pertinent regulations, except where specifically carried through the provisions of this Chapter.

5.2.5 Permitted uses

Uses permitted in a PUD shall be subject to the approval of the Area Plan Commission and the appropriate legislative body.

5.3 PUD SUBMITTAL AND APPROVAL PROCESS

The PUD application shall be accompanied by all plans and documents.

5.3.1 Procedures for Preliminary PUD Plan

A. Pre-application meeting

The applicant shall meet with the Executive Director no less than one (1) month prior to the anticipated Area Plan Commission docket deadline.

B. Preliminary Plan PUD submittal requirements

The Preliminary Plan PUD submittal shall include the following as applicable. Failure to submit any of the following information may result in an incomplete application. Only complete applications shall be considered for placement on the Area Plan Commission docket.

1. General project information

- a. The owner, contract purchaser, or others having an economic interest, for which a PUD is sought, must file a complete application with the Executive Director.
- b. A complete application must include full sized documents and drawings. The submission may be composed of one (1) or more sheets and shall include the following.
 - 1) Name, address and telephone number of the owner. If property ownership is in trust, the name and address of each person or entity owning an interest in the property, and the extent of such ownership interest unless any of such entities is a corporation or a partnership, in which case only those persons owning an interest in excess of fifty (50) percent in such corporation or partnership need be identified by name, address and extent of interest.
 - 2) Name, address and telephone number of the applicant including the name and address of each person or entity owning an interest in the property and the extent of such ownership interest unless any of such entities is a corporation or a partnership, in which case only those persons owning an interest in excess of fifty (50) percent in such corporation or partnership need be identified by name, address and extent of interest. For purposes of this Chapter, the term ownership interest shall include any legal or equitable interest held at the time of the application in the real property which is the subject of the application. The application must include the signature of the owner(s).

- 3) All drawings shall be of an appropriate scale¹.
 - 4) North point, designated as true north.
 - 5) Date of preparation of original drawing and the date of any revisions.
 - 6) The name of the development, with the words "Preliminary PUD Plan"
- c. Payment of a non-refundable application fee as designated in the fee schedule
 - d. Every application must be accompanied by payment for a development review fee in such an amount as prescribed by the Official Fee Schedule, as amended from time to time.
2. Existing conditions and determination of best land use(s)
 - a. A site location map showing the boundary of the proposed PUD
 - b. A legal description of each parcel of property subject to the petition
 - c. Parcel ID numbers
 - d. Relative address
 - e. Existing (prior to rezoning to a PUD) zoning districts and current use of land on the site and on adjacent property within six hundred and sixty (660) feet of the subject site.
 - f. All existing or previously platted streets on the site
 - g. Existing easements, including location, width and purpose
 - h. Other rights-of-way, including railroads and utility rights-of-way, showing existing improvements, if any.
 - i. Existing permanent buildings and structures on the site
 - j. Environmental features including water courses, sinkholes, lakes, ponds, floodplains, wooded areas, and wetlands
 - k. Existing vegetation to be preserved and the locations and nature
 - l. Future land uses
 - m. Other existing conditions data as may be required by Executive Director, Area Plan Commission, the PUD Committee, or the appropriate legislative body.

¹ All drawings shall be at a scale not smaller than one inch equals fifty feet (1"=50') with a scale of one inch equals thirty feet (1"=30') being preferred. Any other scale must be approved by the Executive Director. No individual sheet or drawing shall exceed twenty-four inches by thirty-six inches (24" x 36").

3. Written description of district

The applicant shall provide written narrative description of the PUD describing the character of the development in the PUD, the intent and desired effect of the development, the manner in which the development has been planned to take advantage of the flexibility of the PUD regulations, the superior benefits that would accrue to the residents/users of the development, and all relief sought from the standard application of district requirements in conjunction with the project. The written narrative description should also include any information relative to the anticipated build-out, or completion, of the project, including any phasing of development.

- C. Preliminary Plan PUD review procedures

The review procedure for a Preliminary PUD Plan shall be consistent with the procedures described as follows.

1. Authority

The appropriate legislative body has the authority to grant a rezone for a PUD from the Area Plan Commission in accordance with the provisions of this Chapter.

2. Initiation

- a. The owner of the property, lessee, or contract purchaser of at least fifty (50) percent of the land area for which a PUD is sought may initiate a request for a rezone for a PUD.
- b. The Preliminary Plan, Draft PUD Ordinance and application for the PUD shall be submitted to the Executive Director or Area Plan Commission Office, after certifying the application to be complete, shall initiate a review by the PUD Committee and Technical Review Committee.
- c. The applicant shall attend a joint meeting of the PUD Committee and Technical Review Committee which shall make a report and recommendation to the Area Plan Commission.
- d. The application and the results shall be forwarded to the Area Plan Commission for its consideration, public hearing and recommendations together with the Executive Director's report and such other documents as may be pertinent to the PUD.
- e. The applicant shall be responsible for notice in the newspaper in accordance with IC 5-3-1 as amended.

3. Procedure for decision – Area Plan Commission and appropriate legislative body action

- a. Public hearing

The Area Plan Commission shall hold a public hearing on an application for a PUD. At the hearing, all interested parties shall have an opportunity to be heard.

- b. Area Plan Commission and appropriate legislative body action
 - 1) Within thirty (30) days after the close of the public hearing, the Area Plan Commission shall vote to recommend approval or denial, or approval with conditions on the PUD to the appropriate legislative body by a simple majority of those Area Plan Commission members present and voting. The Area Plan Commission shall provide written certification to the appropriate legislative body.
 - 2) The appropriate legislative body shall act to approve, deny, or approve with conditions the PUD District within ninety (90) days of the legislative body's first meeting following receipt of the certification of Area Plan Commission recommendation.

4. Written findings of fact

The Area Plan Commission in its recommendations with regard to an application for a PUD District must set forth specific report of determinations of fact.

5. Conditions of approval

The Area Plan Commission may recommend and the appropriate legislative body may impose conditions in authorizing a PUD District to make such use more compatible with the use, enjoyment and development of adjacent and nearby properties, to make the use more compatible with the character of the area in which it is located and to eliminate any adverse effect on adjacent and nearby properties and the neighborhood. Any such conditions must be set forth as part of the action approving the PUD District. Such written commitments shall be recorded and made part of the PUD District.

- D. Public hearing and actions on Preliminary PUD Plan

1. Review and actions on the part of the Area Plan Commission and appropriate legislative body shall take place in accordance with this Chapter. The Area Plan Commission may recommend approval, disapproval or approval with amendments, conditions or restrictions with respect to the preliminary PUD plan.
2. If the preliminary PUD plan is approved by the appropriate legislative body, it shall adopt a PUD zoning district designation approving said preliminary plan and plat, if applicable, with conditions as specified and authorizing the preparation of the final plan and plat, if applicable. If a PUD preliminary plan is approved, it shall become effective and its location shall be shown on the Zoning Map. Upon such amendment of the Zoning Map, the use and development of the site shall be governed by the PUD Preliminary Plan, subject to approval of a PUD Final Plan.
3. All conditions imposed as part of any PUD shall run with the land and shall not lapse or be waived as a result of a subsequent change in tenancy or ownership of any or all of said areas, provided, however, that nothing herein shall be construed to limit the right of the developer, his successors or assignee to sell property in said PUD, except for such conditions imposed upon said common open space areas.

4. Approval of the preliminary plan by the appropriate legislative body does not constitute final PUD plan approval, but authorizes submission of a final development plan for approval. Approval of the preliminary plan shall be valid for a period of two (2) years from the date of the appropriate legislative body approval. If a final plan approval is filed in phases, each subsequent phase shall be filed for within two (2) years of the prior phase's approval. If an application for final plan approval for all or a part of a geographic portion of the preliminary plan has not been filed within the two (2) years period, or if a developer has not requested and received approval of a one (1) year extension from the Area Plan Commission, then a resubmission of the preliminary plan shall be required, in accordance with the process of this Section, if the applicant intends to file for final plan approval. In no case shall an Improvement Location Permit or a Building Permit be issued prior to Final PUD Plan approval.

5.3.2 Amendments to an approved Preliminary PUD Plan

A. Minor changes

Minor changes in the location, sitting and height of buildings and structures may be authorized by the Area Plan Commission during the PUD final plan process without additional public hearings if required by engineering or other circumstances not foreseen at the time the concept plan was approved. No change authorized by this sub-section may cause any of the following:

1. A change in the use, intensity or character of the development;
2. A greater than ten (10) percent increase in overall coverage of structures;
3. A greater than ten (10) percent increase in the intensity of use;
4. Five (5) percent or greater reduction in approved open space;
5. Five (5) percent or greater reduction of off-street parking and loading spaces; or
6. A ten (10) percent or greater reduction in required pavement widths.

B. Major changes

All other changes in use, or rearrangement of lots, blocks, building tracts, or any changes in the provision of common open space and changes other than listed above in Section 5.302(A), may be made only if they are shown to be required by changes in conditions that have occurred since the concept plan was approved or by changes in community policy. Said changes may be approved by the appropriate legislative body after report of Executive Director and recommendation by the Area Plan Commission.

1. Any changes to the approved final plan must be recorded as amendments in accordance with the procedures and requirements of Chapter 12, Administration.
2. If there are changes to the concept plan and concept approval granted to the PUD by the Area Plan Commission, but not final approval by the appropriate legislative body, then the applicant is required to be placed back on the Area Plan Commission docket for a public hearing. Applicant shall provide public notice to residents in accordance with the requirements of IC 5-3-1 as amended.

3. If after a second recommendation from the Area Plan Commission, the legislative body denies Preliminary PUD Approval, the applicant shall be required to re-file his application subject to the requirements of this Chapter as if it was an entirely new application.

5.3.3 Procedures for Final PUD Plan

A. Pre-application meeting

The applicant shall meet with the Executive Director no less than one (1) month prior to the anticipated Area Plan Commission docket deadline.

B. Final PUD Plan submittal requirements

The final plan shall include the required information described in this Section. In addition to these submittal requirements, the following shall be submitted.

1. Final Development Plan

- a. A site location map showing the boundary of the proposed PUD
- b. A legal description of each parcel of property subject to the petition
- c. A current plat of survey prepared by a land surveyor registered in the State of Indiana.
- d. Parcel ID numbers
- e. Relative address
- f. Existing (prior to rezoning to a PUD) zoning districts and current use of land on the site and on adjacent property within six hundred and sixty (660) feet of the subject site.
- g. All existing or previously platted streets on the site
- h. Existing easements, including location, width and purpose
- i. Other rights-of-way, including railroads and utility rights-of-way, showing existing improvements, if any.
- j. Existing permanent buildings and structures on the site
- k. Utilities on the site indicating the location, size and invert elevations of storm and combined sewers; the size and location of sanitary sewers; the size and location of water mains; the location of fire hydrants; the direction and distance to the nearest usable water mains and sewers; and the location of private utilities such as gas, electric, and telephone lines and easements. The data can be summarized in a table; however the location of the utilities shall be documented on the map.
- l. Topographic data for the site consisting of existing contours at two-foot intervals.
- m. Environmental features including water courses, sinkholes, lakes, ponds, floodplains, wooded areas, and wetlands

- n. Existing vegetation to be preserved and the locations and nature
 - o. Future land uses
 - p. The location and general design of new lots, landscaping, including fencing, berming and walls, trash collection facilities, any proposed streets, major storm water drainage facilities, main utility lines and facilities, and other features deemed necessary by the Area Plan Commission and appropriate legislative body on all of the contiguous property holdings of such developer, his/her agents, trustees, beneficiaries, or owners, whether or not said contiguous land holdings are intended for immediate development;
 - q. Other existing conditions data as may be required by Executive Director, Area Plan Commission, the PUD Committee, or the appropriate legislative body.
2. Written description of district

The applicant shall provide written development standards that shall include, at a minimum, the following information that will be incorporated into a written PUD Ordinance as described in sub-section PUD Zoning Designation Ordinance:

- a. Narrative description of the PUD describing the character of the development in the PUD, the intent and desired effect of the development, the manner in which the development has been planned to take advantage of the flexibility of the PUD regulations, the superior benefits that would accrue to the residents/users of the development, and all relief sought from the standard application of district requirements in conjunction with the project;
- b. Gross and net area of tract;
- c. Total number of dwelling units proposed;
- d. Lot size for each lot summarized in a table based on project area;
- e. Height of structures;
- f. Setbacks;
- g. Floor area or lot coverage;
- h. Open space;
- i. Project density;
- j. Number of off-street parking spaces proposed;
- k. The location and distance between buildings and structures;
- l. The proposed location and general use of common ground (if any), including recreational areas, plazas, pedestrian ways and major landscape areas including buffer areas;
- m. General landscaping information including number of trees/shrubs, approximate size (at the time of planting) of all plant material by type (such as

deciduous/coniferous trees, ornamental trees, shrub masses and ground cover including grassed areas, ivies, etc.). Landscaping within parking areas shall be included;

- n. Quantification of site area by building coverage, parking, loading and driveways, and common retention/detention, floodplain and/or natural areas;
 - o. The general type and size of all retaining walls, fences and earth berms;
 - p. The general type and size of all refuse collection facilities including screening to be provided;
 - q. Design of all project signage, including project marketing signage, square footage of sign, height, type of sign;
 - r. Describe site lighting including the type of lighting and minimum and maximum light values;
 - s. Project report to include an explanation of the character of the proposed development, verification of the applicant's ownership or contractual interest in the subject site and proposed development schedule;
 - t. Proposed covenants, if any, to govern the use and maintenance of the development and ensure the continued observance of the provisions of the PUD; and
 - u. Additionally, for a proposed PUD that is of a larger size and complexity that impact on the community is not easily ascertained, the Area Plan Commission may require that the petitioner supplement the filing with an impact assessment. The factors that are impacted will be determined at the time the Area Plan Commission reviews the preliminary plan.
 - v. The applicant may be required to provide, at the applicant's expense, additional clarification and/or further detail of the site plan as determined necessary by either the Executive Director or the Area Plan Commission;
3. PUD zoning designation ordinance
- a. A written PUD Ordinance shall be adopted by reference, attached as an exhibit to the preliminary plan submittal, and made part of the PUD Zoning Designation Ordinance;
 - b. A legal metes and bounds description of the entire parcel
 - c. Incorporate the elements in sub-section Written Description of District, into the PUD Ordinance to create specific development or use standards that shall apply to the specific sections of phases. These standards may include, but are not necessarily be limited to permitted uses, prohibited uses, maximum or minimum densities of dwelling units, lot areas, floor areas, building setback lines, building separations, yard areas, structure heights, open space, preservation of natural geological features or plantings, signage, parking, landscaping, design standards, phasing or other standards or conditions deemed appropriate by the Area Plan Commission or appropriate legislative body;

- d. Other restrictions may be required by the Area Plan Commission and appropriate legislative body including, without limitations, one (1) or more or all of those basic design requirements set forth in this Section in order to carry out the intent and purpose of this Chapter.
 4. Establish specific or tentative schedule for phasing the development of the various sections of the PUD.
 5. The final landscape plan with specific location of all plant material, specifying size and species.
 6. The PUD Zoning Designation Ordinance, adopted by reference, attached as an exhibit to the submittal and statement that the master plan is in compliance with the adopted PUD Zoning Designation Ordinance.
 7. A statement placed on the plat indicating that the operation and maintenance of designated common areas, common facilities, common buildings and open spaces shall be under the control of a homeowners association in accordance with the laws of White County governing such associations as provided for in the Application and Approval Process in the Subdivision Control Ordinance.
 8. Construction Activities plan indicating how construction activity will be controlled by addressing contractor ingress/egress, construction parking, maintenance of traffic plan, and street cleaning.
 9. All streets shall be located on the plan. The streets must be placed within a Right of Way (ROW) and shall be accompanied by plans and cross sections.
 10. Finalized copy of covenants, if any, to govern the use and maintenance of the development and ensure the continued observance of the provisions of the PUD.
- C. Final plan review procedures

The applicant may submit for a review meeting by the Area Plan Commission to ensure that the final plan is consistent with the preliminary plan.

1. Procedure for review – Area Plan Commission

a. Public Hearing

The final plan and supporting data shall be filed with Executive Director and forwarded to the Area Plan Commission for determination whether the final plan is in conformity with these regulations and in agreement with the approved concept plan.

b. PUD Committee Recommendation

The PUD Committee shall review the Final PUD and make a recommendation to the Area Plan Commission

c. Area Plan Commission action

Within thirty (30) days of the date the item first appears on the Area Plan Commission agenda, the Area Plan Commission shall vote to recommend approval or denial, or approval with conditions of the PUD final plan by a simple majority of those Area Plan Commission members present and voting.

2. Written Findings of Fact

The Area Plan Commission with regard to an application for a PUD final plan must set forth specific written report of determination on each standard.

5.4 FINAL PLAN APPROVAL NOT ACCEPTANCE OF DEDICATION OFFERS

Approval of a PUD final plan does not constitute acceptance by the appropriate legislative body of the offer of dedication of any streets, utilities, sidewalks, parks or other public facilities shown on the plan. However, the appropriate legislative body may accept any such offer of dedication by resolution and may delay such acceptance until such time that the street department head or his/her designee determines that the public improvements have been completed in a satisfactory manner, and accepted or approved by the appropriate authority. Approval is contingent on the provision of as-built plans that provide a certified engineer's confirmation that the final plans were performed in their entirety.

5.5 FINANCIAL ASSURANCE REQUIREMENTS

The petitioner shall provide financial assurance for the satisfactory installation of all public facilities in the form of bonds or any other assurances as are required in the normal procedures of platting pursuant to the provision of the Application and Approval Process of the White County Subdivision Control Ordinance.

5.6 RECORDING THE FINAL PUD PLAN

All approved plans and any modifications thereof, for any PUD district shall be recorded in the office of the White County Recorder in accordance with the provisions set forth in the Application and Approval Process in the Subdivision Control Ordinance before an Improvement Location Permit or a Building Permit may be issued or any development takes place.

5.7 PROCEDURES FOR PLATTING A PUD

Final Plat approval for any development pursuant to this Section shall be issued in a manner consistent with that of any other plat under the jurisdiction of the Area Plan Commission in compliance with the procedures set forth in the Application and Approval Process of the White County Subdivision Control Ordinance and with any additional requirements or commitments entered into in connection with the approval of the final plan pursuant to this Section.

5.8 FAILURE TO INITIATE CONSTRUCTION AFTER FINAL PUD PLAN APPROVAL

5.8.1 Invalid projects

No approval of a PUD final plan shall be valid for a period longer than two (2) years from the date of approval unless within such period an Improvement Location Permit or a Building Permit is obtained and construction of a building's foundations have

commenced. If the project is determined to be invalid, zoning of the parcel shall revert back to its previous zoning prior to the rezoning to a PUD.

5.8.2 Extensions

The Area Plan Commission may grant a one (1) year extension upon written request of the original applicant if the application submitted is substantially the same as the initially-approved application. At such time as the period of validity of an approved final development plan lapses, the final development plan and all uses, terms and conditions thereof may be declared null and void.

5.8.3 Abandonment

Abandonment shall be deemed to have occurred when no improvements have been made pursuant to the approved PUD final plan for twenty four (24) consecutive months or upon the expiration of two (2) years from the date of approval of the final plan. An amendment may be initiated to the zoning map, as provided by law, so that the land will be zoned into a category or categories that most nearly approximate the prior use or other such zoning category or categories that the legislative body deems appropriate.

5.9 AS-BUILT PLANS REQUIREMENT

Where upon completion of all development, the exact measurements of the location of buildings and structures erected during the development are necessary for public record and shall therefore be recorded. The developer shall submit a copy of the approved Construction Plans (as-built plans), as amended, to the Building Inspector with the exact measurements thereon shown. The Building Inspector, after being satisfied that the measurements are substantially the same as indicated on the originally approved final plan(s), shall approve, date and sign said Construction Plans for the project, which the developer shall then record.

5.10 LIMITATION OF REZONING

Unless the project is abandoned, no amendments to the zoning map concerning PUD final plan district shall be initiated by the Area Plan Commission or the appropriate legislative body before the completion of the development provided that the development is in conformity with the approved PUD final plan and the development is proceeding in accordance with the time requirements imposed therein.

5.11 PROCEEDINGS FOR ENFORCEMENT

In case any building or structure is constructed, reconstructed, altered, repaired, converted, or maintained, or any building, structure, or land is used in violation of this Ordinance or other regulation made under the authority conferred thereby, the appropriate legislative body, in addition to other remedies, may institute any appropriate action or proceedings to: prevent the unlawful construction, reconstruction, alteration, repair, conversion, maintenance, or use; prevent any illegal act, conduct, business, or use in or about the premises; prevent the occupancy of the building, structure, or land; or restrain, correct, or abate the violation.

5.12 FEES

Any person, firm, corporation, or agent, who shall file an application for amendment or application for an appeal, variation, or special use, or for any other certificate or license required under the terms of this Ordinance, shall be charged a fee in accordance with a schedule of fees, as contained within the appropriate legislative body ordinance.

5.13 PENALTIES

Any person, firm or corporation who violates, disobeys, omits, neglects, or refuses to comply with the rules of this Chapter, shall upon conviction, be fined in accordance with Chapter 13, Enforcement. Each day that a violation continues to exist shall constitute a separate offense.

CHAPTER 6 OVERLAY DISTRICTS

6.0 PURPOSE AND INTENT

The purpose of creating Overlay Districts is to provide for development in areas that have a unique nature or needs. Thus, to facilitate the best use of these specific geographic areas, development standards, regulations, special exemptions or requirements are applied to applicable zoning districts above and beyond those developmental standards, regulations, special exemptions or requirements which have been established for the base zoning district.

6.1 ORDINANCE REPEAL

White County Ordinance #02-08-05-01 White County Ordinance For Flood Hazard Areas is hereby repealed by passage of this Ordinance.

6.2 CONSERVATION AND FLOOD PLAIN OVERLAY DISTRICT

The purpose of the Conservation and Flood Plain Overlay (CFO) District is to provide for development within a flood plain or flood hazard area while reducing the potential for: Loss of life and property; health and safety hazards; and the potential for extraordinary public expenditures for flood protection and relief. The boundaries of all CFO Districts shall coincide with those boundaries established by the countywide floodplain maps produced by the Federal Emergency Management Agency (FEMA) for the applicable jurisdiction, as amended from time to time. Specifically, a CFO District is intended to:

- A. Prevent unwise development from increasing flood or drainage hazards to others.
- B. Protect new buildings and major improvements to buildings from flood damage.
- C. Protect human life and health from the hazards of flooding.
- D. Lessen the burden on the taxpayer for flood control projects, repairs to flood damaged public facilities and utilities, and flood rescue and relief operations.
- E. Maintain property values and a stable tax base by minimizing the potential for creating flood blighted areas.
- F. Make federally subsidized flood insurance available for structures and their contents in White County by fulfilling the requirements of the National Flood Insurance Program.
- G. Minimize prolonged business interruptions and loss of employment.

6.2.2 Regulations

Regulations pertaining to the management of the CFO and Floodplain Overlay District are provided for in Appendix E. Appendix E has been constructed to comply with the requirements of the National Flood Insurance Program, the Indiana Department of Natural Resources and the Federal Emergency Management Agency.

6.2.3 District Boundaries

District boundaries are defined by the official maps issued by the Federal Emergency Management Agency or Federal Insurance Administration which pertain to areas of flood hazards and regulatory floodways and any other maps pertaining to Flood Hazard Areas and provided for in Appendix E.

CHAPTER 7 RENEWABLE ENERGY SYSTEMS WIND AND SOLAR SITING REGULATIONS

7.0 PURPOSE AND INTENT

7.0.1 Purpose

The purposes of this Chapter are to:

- A. Assure that any development and production of wind and solar generated electricity in White County is safe and effective;
- B. Facilitate economic opportunities for local residents; and
- C. Promote the supply of wind and solar clean and renewable energy sources as part of a national effort to reduce reliance on carbon-based energy production.

7.0.2 Intent

It is the intent of the Wind and Solar siting regulations to provide a regulatory scheme for the construction and operation of wind and solar energy projects in White County subject to reasonable restrictions. These regulations are intended to preserve the health, safety and general welfare of the public.

7.1 APPLICABILITY

The provisions of this Chapter are applicable to those districts which allow wind and/or solar energy developments and are intended to govern the siting and development of wind and solar energy projects in a manner compatible with the long-term safety, health and welfare of the community.

7.2 PROHIBITION

No applicant shall construct, operate, or locate a wind or solar energy project within White County without having fully complied with the provisions of this Chapter.

7.3 CONFLICT WITH OTHER REGULATIONS

Nothing in this Chapter is intended to preempt other applicable state and federal laws or regulations, including compliance with all Federal Aviation Administration rules and regulations and shall comply with the notification requirements of the Federal Aviation Administration. Nor are they intended to interfere with, abrogate, or annul any other ordinance, rule, or regulation, statute or other provision of law. In the event that any provision of these regulations imposes restrictions different from any other ordinance, rule, regulation, statute, or provision of law, the provisions that are more restrictive or that impose higher standards shall govern.

7.4 DISTRICT REGULATIONS – WECS

7.4.1 Location

Commercial, Non-commercial and Micro WECS will be permitted, or not permitted, in various districts as prescribed by the Official Schedule of Uses (Appendix A).

7.4.2 Height

A. Non-Commercial WECS or Meteorological Towers

Any Non-commercial WECS Turbine or Meteorological Tower greater than two hundred (200) feet in height shall require a variance approval from the Board of Zoning Appeals.

B. Commercial WECS or Operational Support Meteorological Towers

For Commercial WECS Turbines and Operational Support Meteorological Towers there are no limitations on height, except those height limitations imposed by Federal Aviation Administration rules and regulations.

C. Micro WECS

No Micro WECS Turbine shall exceed sixty (60) feet in height.

7.5 Setback Requirements

7.5.1 Minimum setback distances for COMMERCIAL WECS TOWERS

Distance from the vertical centerline of the WECS Tower to...	Minimum Setback Distance
Any Participating Landowner's property line	<p>The full length of one blade of the WECS Turbine being placed on such property.</p> <p>(i) The setback requirement is waived if the affected adjoining landowners sharing the common property line are Participating Landowners.</p> <p>(ii) A WECS Turbine may be placed up to the property line, if a fully executed and recorded written waiver agreement is secured from the affected adjoining Non-Participating Landowner.</p>
Any Non-Participating Landowner's property line	<p>1.1 times the total height of the WECS Turbine when the blade is at its highest point (This requirement may be waived subject to the written consent of the owner of an affected Non-Participating Landowner)</p>
The nearest point on the outer wall of a residential dwelling	<p>Two (2) times the total height of the WECS Turbine when the blade is at its highest point (This requirement may be waived subject to the written consent of the Landowner of an affected property, whether Participating or Non-Participating)¹</p>

¹ The setback for residential dwellings shall be reciprocal in that no residential dwelling shall be constructed within one thousand (1,000) feet of a COMMERCIAL WECS Turbine, measured from the vertical centerline of the WECS Tower to the nearest point on any outer wall of the dwelling.

Distance from the vertical centerline of the WECS Tower to...	Minimum Setback Distance
Any property line of a Participating Landowner	The length of one (1) blade of the WECS Turbine. This setback requirement is waived if the affected joining landowner sharing the common property line is a Participating Landowner
Any property line of a Non-Participating Landowner, that is not the property line of any undeveloped land that is zoned or platted for residential use	One and one tenth (1.1) times the total height of the WECS Turbine when the blade tip is at its highest point. A WECS Turbine may be placed up to the property line if a fully executed and recorded written waiver agreement is secured from the affected adjoining Non-Participating Landowner.
The property line of any undeveloped land that is zoned or platted for residential use	Two (2) times the total height of the WECS Turbine when the blade is at its highest point
The centerline of any public road right-of-way	One and one tenth (1.1) times the total height of the WECS Turbine when the blade tip is at its highest point ²
The centerline of any railroad or public utility easement or rights-of-way	One and one tenth (1.1) times the total height of the WECS Turbine when the blade tip is at its highest point
The closest boundary point on public conservation lands	Seven hundred and fifty (750) feet
The closest boundary point of a wetlands, as defined by the U.S. Army Corps of Engineers	As determined by a permit obtained from the Army Corps of Engineers
The Tippecanoe River shoreline as delineated on the County GIS mapping system	One-half (1/2) mile
A property line of a State Park	One (1) mile
The incorporated limits of a municipality or GIS boundary line of Idaville and Buffalo	One (1) mile. This limitation may be waived, in part or in full, with the written consent of the effected legislative body

² The setback shall be measured from a future public rights-of-way width if a planned public road improvement or expansion is known at the time of application.

Distance from the vertical centerline of the WECS Tower to...	Minimum Setback Distance
The nearest edge of any of the rights-of-way for any utility transmission or distribution line	One and two tenths (1.2) times the total height of the WECS Turbine when the blade tip is at its highest point
The centerline of any runway located on a public use airport, private use airport or municipal airport	Five (5) miles for the White County Airport; All other airports, one and one tenth (1.1) times the total height of the WECS Turbine when the blade is at its highest point

7.5.2 Commercial WECS Power Collection and Transmission System

A. WECS substation

For all Substations, setbacks from property lines are waived if the affected adjoining landowners sharing the common property line are all Participating Landowners.

B. Poles

For all poles carrying overhead wiring connecting Commercial WECS Towers to a Substation for connection to a utility's electric transmission line, there are no setback requirements from property lines as long as the poles are located within a recorded easement for such purpose.

7.5.3 Minimum Setback Distances for NON-COMMERCIAL and MICRO WECS TOWERS

Distance from...	Minimum Setback Distance
Any property line as measured from the vertical centerline of the WECS Tower	One and one tenth (1.1) times the total height of the WECS Turbine when the blade tip is at its highest point, provided that the distance is no less than the required yard setback prescribed for that district
A residential dwelling as measured from the vertical centerline of the WECS Tower to the nearest point on the outer wall surface of the residential dwelling	One and one tenth (1.1) times the total height of the WECS Turbine when the blade tip is at its highest point
A public road right-of-way as measured from the vertical centerline of the WECS Tower to the closest edge of the right-of-way	One and one tenth (1.1) times the total height of the WECS Turbine when the blade tip is at its highest point, provided that the distance is no less the required yard setback prescribed for that district ³
Other rights-of-way, such as railroads and public utility easements as measured from the vertical centerline of the WECS Tower to the closest edge of the right-of-way	One and one tenth (1.1) times the total height of the WECS Turbine when the blade tip is at its highest point, provided that the distance is no less than the required yard setback prescribed for that district
Public conservation lands as measured from the vertical centerline of the WECS Tower to the nearest point of the public conservation land in question	Seven hundred and fifty (750) feet
Wetlands, as defined by the U.S. Army Corps of Engineers, as measured from the vertical centerline of the WECS Tower to the nearest point of the subject wetland	As determined by a permit obtained from the Army Corps of Engineers
The Tippecanoe River as measured from the vertical centerline of the WECS Tower to the River shoreline as delineated on the County GIS mapping system	One half (1/2) of a mile
Above-ground electric transmission lines as measured from the vertical centerline of the WECS Tower	One and one tenth (1.1) times the total height of the WECS Turbine when the blade tip is at its highest point

³ The setback shall be measured from the closest boundary of any future public rights-of-way if a planned public road improvement or expansion is known at the time of application.

7.5.4 Horizontal extension for Non-commercial and Micro WECS

The furthest horizontal extension (including guy wires) shall not extend into a required setback of the applicable zoning district or be closer than twelve (12) feet to any primary structure or public right-of-way easement for any above-ground telephone, electric transmission or distribution line.

7.5.5 Minimum setback distances for all Meteorological Towers

Distance from a...	Minimum Setback Distance
Property line as measured from the vertical centerline of the Meteorological Tower	One and one tenth (1.1) times the total height of the Meteorological Tower, provided that the distance is no less than the required yard setback (i) The setback requirement is waived if the affected adjoining landowners sharing a common property line are Participating Landowners
Residential dwelling as measured from the vertical centerline of the Meteorological Tower to the nearest point on the outer wall surface of the residential dwelling	One and one tenth (1.1) times the total height of the Meteorological Tower
Public road right-of-way as measured from the vertical centerline of the Meteorological Tower to the closest edge of the right-of-way	One and one tenth (1.1) times the total height of the Meteorological Tower, provided that the distance is no less than the required yard setback ⁴
Other rights-of-way, such as railroads and public utility easements, as measured from the vertical centerline of the Meteorological Tower to the closest edge of the right-of-way	One and one tenth (1.1) times the total height of the Meteorological Tower, provided that the distance is no less than the required yard setback

7.5.6 Horizontal extension for all Meteorological Towers

The furthest horizontal extension for any meteorological tower (including guy wires) shall not extend into a required setback of the applicable zoning district or be closer than twelve (12) feet to any primary structure, or public right-of-way easement for any above-ground telephone, electric transmission or distribution lines.

⁴ The setback shall be measured from the closest boundary of any future public rights-of-way if a planned public road improvement or expansion is known at the time of application.

7.6 SAFETY DESIGN AND INSTALLATION STANDARDS

7.6.1 Equipment type

A. Turbines

All turbines shall be constructed of commercially available equipment.

B. Meteorological Towers

All Meteorological Towers may be guyed.

C. Experimental, or proto-type equipment

Experimental or proto-type equipment still in testing which does not fully comply with industry standards, may be approved by the Board of Zoning Appeals per the variance process established by this Ordinance.

7.6.2 Industry standards and other regulations

All WECS shall conform to applicable industry standards, as well as all local, state and federal regulations. An applicant shall submit certificate(s) of design compliance that wind turbine manufacturers have obtained from Underwriters Laboratories, Det Norske Veritas, Germanischer Lloyd Wind Energie, or an equivalent third party.

7.6.3 Controls and brakes

A. Braking system

All WECS Turbines shall be equipped with a redundant braking system. This includes both aerodynamic over speed controls (including variable pitch, tip, and other similar systems) and mechanical brakes. Stall regulation shall not be considered a sufficient braking system for over speed protection.

B. Operation mode

All mechanical brakes shall be operated in a fail-safe mode.

7.6.4 Electrical components

A. Standards

All electrical components of all WECS shall conform to applicable local, state and national codes, and any relevant national and international standards.

B. Collection cables

All electrical collection cables between each WECS Turbine shall be located underground wherever possible.

C. Transmission lines

All transmission lines that are buried should be at a depth consistent with or greater than local utility and telecommunication underground lines standards or as negotiated with the land owner or the land owner's designee until the same reach the property line or a substation adjacent to the property line.

7.6.5 Color and Finish

In addition to all applicable Federal Aviation Administration requirements, the following shall also apply:

A. WECS turbines

All WECS turbines shall be white, grey, or another non-obtrusive color.

B. Finishes

Finishes shall be matte or non-reflective.

C. Exceptions

Exception may be made for all Meteorological Towers where concerns exist relative to aerial spray applicators.

7.6.6 Warnings

A. Commercial WECS

The following notices shall be posted for all Commercial WECS

1. A sign or signs be posted on the pad-mounted transformer and the Substation(s) warning of high voltage
2. Private roads providing access to Commercial WECS shall have posted an Emergency-911 address road sign

B. Guy wires and anchor points

For all guyed towers, one of the following warning mechanisms shall be used for each anchor point

1. Visible or reflective objects

Visible and reflective objects, such as flags, plastic sleeves, reflectors, or tape placed on the anchor points of guy wires and along the innermost guy wires up to eight (8) feet above the ground

2. Visible Fencing

Visible fencing not less than four (4) feet in height installed around anchor points of guy wires.

C. Non-commercial WECS and Micro WECS

The following notices shall be clearly visible on all Non-commercial and Micro WECS Towers and accessory facilities;

1. "No Trespassing" signs shall be attached to any perimeter fence.

2. "Danger" signs shall be posted at the height of five (5) feet on WECS Towers and accessory structures.
3. A sign shall be posted on the WECS Tower showing an emergency telephone number.
4. The manual electrical and/or overspeed shutdown disconnect switch(es) shall be clearly labeled.

D. Meteorological Towers

Consideration shall be given to painting of the aviation warnings as required by the Federal Aviation Administration on all Meteorological Towers.

7.6.7 Climb Prevention

All Commercial WECS Tower designs shall include features to deter climbing or be protected by anti-climbing devices such as:

- A. Fences with locking portals at least six (6) feet in height; or
- B. Anti-climbing devices fifteen (15) feet vertically from the base of the WECS Tower; or
- C. Locked WECS Tower doors.

7.6.8 Blade Clearance

The minimum distance between the ground and any protruding blade utilized on a Commercial WECS Turbines shall be twenty-five (25) feet as measured at the lowest point of the arc of the blades. The minimum distance between the ground and any protruding blade utilized on all Non-commercial or Micro WECS Turbines shall be a minimum of fifteen (15) feet as measured at the lowest point of the arc of the blade, provided the rotor blade does not exceed 20 feet in diameter. In either instance, the minimum distance shall be increased as necessary to provide for vehicle clearance in locations where over-sized vehicles might travel.

7.6.9 Lighting

- A. Intensity and frequency

All lighting, including lighting intensity and frequency of strobe, shall adhere to but not exceed requirements established by Federal Aviation Administration permits and regulations.

- B. Shielding

Except with respect to lighting required by the Federal Aviation Administration, lighting may require shielding so that no glare extends substantially beyond any WECS Turbine.

7.6.10 Materials handling, storage and disposal

A. Solid Wastes

All solid wastes whether generated from supplies, equipment, parts, packaging, operation or maintenance of the WECS, including old parts and equipment related to the construction, operation and/or maintenance of the WECS shall be removed from the site promptly and disposed of in accordance with all federal, state, and local laws.

B. Hazardous materials

All hazardous materials or waste related to the construction, operation and/or maintenance of any WECS shall be handled, stored, transported and disposed of in accordance with all applicable local, state and federal laws.

7.7 OTHER APPLICABLE STANDARDS

7.7.1 Guyed wire anchors

No guyed wire anchors shall be allowed within any required public road right-of-way setback.

7.7.2 Sewer and water

All facilities or structures that are part of the WECS Project shall comply with the existing septic and well regulations as required by the White County Health Department and/or the State of Indiana Department of Public Health.

7.7.3 Noise and vibration

The noise level of the wind power device associated with a Non-commercial WECS shall be no greater than an average sound level of fifty (50) A-weighted decibels as modeled at the closest outer wall of the nearest principal structure on the subject lot or on an abutting lot if closer to the principal structure on that lot . All other noise and vibration levels shall be in compliance with all county, state and federal regulations.

7.7.4 Utility interconnection

The WECS, if interconnected to a utility system, shall meet the requirements for interconnection and operate as prescribed by the applicable regulations of the electrical utility, as amended from time to time.

7.7.5 Signage

All signs pertaining to a WECS Project must comply with Chapter 10, Sign Standards, with the following exceptions.

A. Surface area

No sign shall exceed sixteen (16) square feet in surface area.

B. Height

No sign shall exceed eight (8) feet in height.

C. Manufacturers or owners company name and/or logo

The manufacturers or owner's company name and/or logo may be placed upon the compartment containing the electrical equipment.

D. Other signs and logos

No other signs or logos shall be placed or painted on any structure or facility that is part of the WECS Project.

7.7.6 Feeder lines

Feeder lines installed as part of any WECS project shall not be considered an essential service. To wit, all communications and feeder lines installed as part of any WECS shall be buried underground wherever possible.

7.7.7 Other appurtenances

No appurtenances other than those associated with the WECS construction, operations, maintenance, decommissioning/removal, and permit requirements shall be connected to any WECS Tower except with express, written permission by the Board of Zoning Appeals.

7.8 OPERATION AND MAINTENANCE

7.8.1 Physical modifications

In general, any physical modification to any WECS that alters the mechanical load, mechanical load path, or major electrical components shall require re-certification. Like-kind replacements shall not require re-certification. Therefore, prior to making any physical modification, the owner or operator shall confer with the Building Inspection Department and Area Plan Staff to determine whether the physical modification requires re-certification.

7.8.2 Interference

Prior to construction, a communications study to minimize interference with public or public serving utility microwave transmissions shall be completed. If necessary, the applicant, owner and/or operator shall mitigate interference with electromagnetic communications, such as radio, telephone, microwaves, or television signals caused by any WECS. In addition, the applicant, owner, and/or operator shall comply with the following:

A. Pre-construction

The applicant shall complete a communications study prior to construction so as to minimize interference with any public or public serving utility microwave transmissions.

B. Post-construction

If, after construction of the WECS, the owner or operator receives a written complaint related to interference with the broadcast of residential television,

telecommunication, communication or microwave transmissions, the WECS owner or operator shall take reasonable steps to mitigate said interference. Interference with private telecommunications systems such as GPS shall be between the company and the complainant.

C. Failure to remedy a complaint

If an agreement to remedy a known interference is not reached within ninety (90) days, appropriate action will be taken, which may result in requiring the WECS to become inactive. This does not apply to interference with private telecommunications systems.

7.8.3 Declaration of public nuisance

Any WECS thereof declared to be unsafe by the White County Area Plan Executive Director or Building Inspector by reason of inadequate maintenance, dilapidation, obsolescence, fire hazard, damage or abandonment is hereby declared to be a public nuisance and shall be abated by repair, rehabilitation, demolition or removal in accordance with the approved Decommissioning Plan.

7.9 DECOMMISSIONING PLAN

Prior to receiving an Improvement Location Permit and Building Permit under this Ordinance, the Board of County Commissioners and the applicant, owner and/or operator shall formulate a decommissioning plan outlining the anticipated means and cost of removing a Commercial WECS project at the end of its serviceable life or upon becoming a discontinued or abandoned use to ensure that the Commercial WECS project is properly decommissioned.

7.9.1 Content

A decommissioning plan shall include, at a minimum, language to the following:

A. Assurance

Written assurance that the Commercial WECS project will be properly decommissioned upon the project life or in the event that the WECS Project is abandoned.

B. Cost estimates

The applicant shall provide a contractor cost estimate for demolition and removal of the WECS project. The cost estimates shall be made by a competent party: such as a professional engineer, a contractor capable of decommissioning or a person with suitable expertise or experience with decommissioning WECS projects.

C. Financial assurance

Applicant will provide financial assurance in an amount at least equal to said demolition and removal contractor cost estimate, through the use of a bond, letter of credit or other security acceptable to the County, for the cost of decommissioning each WECS Project and related improvements constructed under the permit. Said security will be released when each WECS Project is

properly decommissioned as determined by the White County Board of Commissioners.

D. Abandonment by the owner or operator

In the event of abandonment by the owner or operator, the applicant will provide an affidavit to the White County Board of Commissioners representing that all easements and/or leases for WECS Projects shall contain terms that provide financial assurances, including access to the salvage value of the equipment, for the property owners to ensure that the WECS Projects are properly decommissioned within one (1) year of expiration or earlier termination of the WECS Project.

7.9.2 Discontinuation and abandonment

A. Discontinuation

Any WECS or WECS Turbine shall be considered a discontinued use after one (1) year without energy production, unless a plan is developed and submitted to the White County Area Plan Department outlining the steps and schedule for returning the WECS or WECS Project to service.

7.9.3 Removal

An applicant's obligations shall include removal of all physical material pertaining to the project improvements to no less than a depth of four (4) feet below ground level within three hundred sixty-five (365) days of the discontinuation or abandonment of the WECS or WECS Project, and restoration of the project area to as near as practicable the condition of the site immediately before construction of such improvements. Removal obligations shall be completed by the owner or by White County at the owner's expense.

7.9.4 Written notices

Prior to implementation of the existing procedures for the resolution of such default(s), the appropriate County body shall first provide written notice to the owner and/or operator, setting forth the alleged default(s). Such written notice shall provide the owner and/or operator a reasonable time period not to exceed sixty (60) days, for good faith negotiations to resolve the alleged default(s).

7.9.5 Costs incurred by the County

If the County removes a WECS Turbine and appurtenant facilities, it may sell the salvage to defray the costs of removal. By approval, the permittee or grantor grants a license to White County to enter the property to remove a WECS Turbine and appurtenant facilities pursuant to the terms of an approved decommissioning plan.

7.10 LIABILITY INSURANCE – LIABILITY

The owner or operator of any WECS shall maintain a current general liability policy covering bodily injury and property damage and may be required to name White County as an additional insured with dollar amount limits per occurrence, in the aggregate, and a deductible, which is suitable to the County.

A project developer and project owner are liable for all damages to waterways, drainage ditches, filed tiles, or other drainage related infrastructure caused by the construction, installation or maintenance of any WECS and related improvements constructed under the permit and is responsible for completely repairing, to near original condition, so as to not impede the natural flow of water. All repairs must be completed within a reasonable period of time and to the satisfaction of the unit and as stated in an applicable lease or other agreement with a landowner subject to applicable federal, state and local drainage laws and regulations.

7.11 APPLICATION PROCEDURES

Permits and variances shall be applied for and reviewed under the procedures established by this Ordinance and shall include the following information:

7.11.1 Applications for All Wind Energy Conversion Systems Projects

An application for all WECS projects shall include the following information:

A. Contact information of project applicant

The name(s), address(es), and phone number(s) of the applicant(s), as well as a description of the applicant's business structure and overall role in the proposed project.

B. Contact information of project owner(s)

The name(s), address(es), and phone number(s) of the owner(s), as well as a description of the owner's business structure and overall role in the proposed project, and including documentation of land ownership or legal control of the property on which the WECS project is proposed to be located. The Area Plan Staff shall be informed of any changes in ownership.

C. Contact information of the project developer(s)

The name(s), address(es), and phone number(s) of the developer(s), as well as a description of the developer's business structure and overall role in the proposed project.

D. Contact information of the project developer(s)

The name(s), address(es), and phone number(s) of the operator(s), as well as a description of the operator's business structure and overall role in the proposed project.

E. Legal description

The legal description, address, and general location of the project.

F. Project description

A WECS Project description, including to the extent possible, information on each wind turbine proposed, including:

1. Number of turbines;
2. Type;

3. Name plate generating capacity;
 4. Tower height;
 5. Rotor diameter;
 6. Total height;
 7. Anchor base;
 8. The means of interconnecting with the electrical grid;
 9. The potential equipment manufacturer(s); and
 10. All related accessory structures
- G. A site layout plan
- A site layout plan, drawn at an appropriate scale, showing distances pertaining to all applicable setback requirements and certified by a registered land surveyor.
- H. Engineering certification
- For all WECS, the manufacturer's engineer or another qualified registered professional engineer shall certify, as part of the Improvement Location permit application, that the foundation and tower design of the WECS is within accepted professional standards, given local soil and climate conditions. An engineering analysis of the WECS Tower showing compliance with the applicable regulations and certified by a licensed professional engineer shall also be submitted. The analysis shall be accompanied by standard drawings of the WECS Tower, its base, and its footings.
- I. Proof correspondence and cooperation with wildlife agencies
- For the purposes of preventing harm to migratory birds and in compliance with the Migratory Bird Treaty Act, the applicant shall provide written documentation that he or she is in direct correspondence and cooperation with the U.S. Fish and Wildlife Service and the Indiana Department of Natural Resources.
- J. Certification that the project owner/developer has used industry standard computer modeling for each Wind Power Device to estimate the amount of shadow flicker anticipated to be caused by the wind power device and, that such modeling indicates that no wind power device will expose any dwelling on a Non-Participating Landowner's property to more than thirty (30) hours per year of shadow flicker. (The thirty (30) hours per year shadow flicker limitation may be waived subject to the written consent of the owner of each affected Non-Participating Landowner).
- K. Certification and description of the WECS Turbine light mitigation technology to be used on the project. The light mitigation technology requirement shall be waived upon written demonstration by the project owner or developer that such technology components are not readily available, that the FAA denies approval of such technology use or if such technology is not economically feasible.
- L. Any other item reasonably requested by the Area Plan Staff.

7.11.2 Applications for Non-commercial Wind Energy Conversion Systems Projects

In addition to the application requirements listed in 7.11.1, Applications for All Wind Energy Conversion Systems Projects, applications for Non-commercial WECS shall also include the following information:

A. Demonstration of energy need

The primary purpose of the production of energy from a Non-Commercial WECS project shall be to serve the energy needs of that tract. The applicant(s) shall demonstrate how much energy is needed and how the proposed size and number of the WECS Turbines fulfills this need. Net-metering may be allowed, but shall not be the primary intent of the WECS project.

B. Statement of Federal Aviation Administration compliance

The applicant shall provide a statement of compliance to all applicable Federal Aviation Administration rules and regulations, including any necessary approvals for installations within close proximity to an airport.

C. Utility notification

No Non-commercial WECS shall be installed until evidence has been given that the local utility company has been informed of the customer's intent to install an interconnected customer-owned generator. Off-grid systems shall be exempt from this requirement.

D. Compliance with National Electrical Code

A line drawing of the electrical components in sufficient detail to allow for a determination that the manner of installation conforms to the National Electrical Code. This information is frequently supplied by the manufacturer.

7.11.3 Applications for Commercial Wind Energy Conversion Systems Projects

In addition to the application requirements listed in 7.11.1, applications for all Commercial WECS Projects shall also include the following information:

A. A preliminary site layout plan

In place of the site layout plan described in 7.11.1(F), applications for all Commercial WECS Projects shall include a preliminary site layout plan with distances drawn to an appropriate scale illustrating the following;

1. Property lines, including identification of adjoining properties;
2. The latitude and longitude of each individual WECS Turbine, along with individual identification of each WECS Turbine;
3. Dimensional representation of the structural components of the WECS Turbine construction including the base and footings;
4. WECS Turbine access roads;
5. Substations;
6. Electrical cabling;

7. Ancillary equipment;
 8. Primary structures within one quarter (1/4) mile of all proposed WECS Towers;
 9. Distances from each individual WECS Tower to each setback requirement;
 10. Location of all public roads which abut, or traverse the proposed site
 11. The location of all above-ground utility lines within a distance of two (2) times the height of any proposed WECS Turbine;
 12. The location of any historic or heritage sites as recognized by the Division of Historic Preservation and Archeology of the Indiana Department of Natural Resources, within one (1) mile of a proposed WECS Tower; and
 13. The location of any wetlands based upon a delineation plan prepared in accordance with the applicable U.S. Army Corps of Engineers requirements and guidelines, within one (1) mile of a proposed WECS Tower.
- B. Topographic map
- A USGS topographical map, or map with similar data, of the property and the surrounding area, including any other WECS Tower within a ten (10) rotor distance, but no less than a one quarter (1/4) mile radius, from the proposed project site, with contours at not more than five (5) foot intervals.
- C. Noise profile
- The project owner shall provide certification that the wind power device will operate in a manner such that the sound attributable to the wind power device will not exceed an hourly average sound level of fifty (50) A-weighted decibels as modeled at the outer wall of an affected dwelling. (This requirement may be waived subject to the written consent of the owner of an affected property)
- D. A Wind Power Project developer must provide certification that each wind power device will minimize and mitigate impacts to;
1. Television signals;
 2. Microwave signals;
 3. Agricultural global positioning systems;
 4. Military defense radar;
 5. Radio reception; and;
 6. Weather and doppler radar.
- E. Location of all known WECS Towers within one (1) mile of the WECS Project Area, including a description of the potential impacts on said WECS Towers.
- F. Copy of the WECS Project Communications Study

7.11.4 Applications for all Meteorological Towers

Applications for all Meteorological Towers shall include the following information:

- A. A copy of the agreement where the landowner has authorized the placement of a Meteorological Tower on their property.
- B. Preliminary site layout plan
 - A preliminary site layout plan with distances drawn to an appropriate scale including the following:
 - 1. Property lines, including identification of adjoining properties;
 - 2. The latitude and longitude of each individual Meteorological Tower;
 - 3. Dimensional representation of the structural components of the tower construction, including the base and footings;
 - 4. Electrical cabling;
 - 5. Ancillary equipment;
 - 6. Required setback lines;
 - 7. Location of all public roads which abut, or traverse the proposed site;
 - 8. The location of all above-ground utility lines within a distance of 2 times the height of any proposed tower;
 - 9. The location of all underground utility lines; and
 - 10. Any other items reasonably requested by the Area Plan Department.
- C. Variance approval if any Non-commercial Meteorological Tower is greater than two hundred (200) feet in height.

7.11.5 Aggregated project applications

Aggregated projects may jointly submit a single application and be reviewed under joint proceedings, including notices, hearing, and reviews and as appropriate, approvals.

7.11.6 Fees

- A. Commercial, Non-commercial and Micro WECS Projects, Meteorological Towers, and any accessory buildings:
 - As prescribed by the County's Official Schedule of Fees.
- B. Aggregated WECS Projects
 - Applications will be assessed fees for each construction phase within a single WECS Project, as prescribed by the County's Official Fee Schedule.

7.11.7 Permits

A. Before any Improvement Location or Building Permit may be issued for any Commercial, Non-commercial or Micro WECS Turbines or for any WECS project accessory structure, the following must be satisfied:

1. Completion of all application requirements as provided for in this Chapter or a required elsewhere in this Ordinance;
2. A copy of all Memorandum of Agreements signed by Participating Landowners authorizing the placement of the identified WECS Turbines on the landowner's property and/or adjoining properties shall be provided; and,
3. A fully executed setback waiver agreement signed by a Non-participating Landowners for adjoining properties shall be provided, when applicable;

B. Aggregated WECS Projects

For aggregated WECS Projects, Improvement Location Permits and, when applicable, Building Permits will be issued individually for each WECS Turbine.

C. Meteorological Tower

Each meteorological tower requires issuance of an Improvement Location Permit prior to construction. Building permits are not required for meteorological towers. An ILP may be issued upon completion of all application requirements as provided for in this Chapter or as required elsewhere in this Ordinance.

7.12 PRE-CONSTRUCTION REQUIREMENTS

Prior to the issuance of any Improvement Location Permit or Building Permit, the following shall be submitted to and reviewed by the Area Plan Staff, who shall certify that the following are in compliance with all applicable regulations:

7.12.1 FAA permit application

A Federal Aviation Administration permit application and/or project approval notification.

7.12.2 Decommissioning plan

A fully executed decommissioning plan approved by the County Commissioners or proof from that body that a waiver from this requirement has been granted.

7.12.3 Economic Development, Drainage, and Road Use and Maintenance Agreements

A fully executed Economic Development Agreement, a Drainage Agreement and a fully executed Road Use and Maintenance Agreement approved by the County Commissioners a copy of which shall be provided to the Area Plan Staff. The Drainage Agreement must prescribe or reference provisions to address crop and field tile damages or proof from that body that a waiver from one or more of these requirements has been granted.

7.12.4 Erosion control plan

An erosion control plan developed in consultation with the Natural Resources Conservation Services (NRCS), and any storm water quality management plan adopted by the applicable jurisdiction.

7.12.5 Utility plan

A utility plan drawn to the same scale as the site layout plan illustrating the location of all underground utility lines associated with the total WECS Project.

7.12.6 Avoidance and mitigation of damages to public infrastructure

In addition to complying with the approved Road Use and Maintenance Agreement, an applicant, owner, developer or operator proposing to use any county road(s), for the purpose of transporting any component of a Commercial WECS Project and/or equipment for construction, operation or maintenance of a Commercial WECS Project, shall comply with the following pre-construction requirements.

A. Identification of roads and services

Provide a written delineation of all routes, roads and services to be used for construction and maintenance purposes. If the delineation includes a public road, written approval from the White County Highway Superintendent shall be provided.

B. Pre-construction survey

The applicant shall conduct a pre-construction baseline survey acceptable to the White County Highway Superintendent to determine existing road conditions for assessing potential future damage. The survey shall include photographs, or video, or a combination thereof, and a written agreement to document the condition of the public facility. Upon execution, such agreement shall be provided to the Area Plan Staff.

7.13 CONSTRUCTION REQUIREMENTS

During construction, the applicant shall demonstrate that the following requirements are being met:

7.13.1 Dust control

Reasonable dust control measures shall be required by the County during construction of a Commercial WECS Project.

7.13.2 Drainage

Reasonable storm water best management practices as required by the approved Drainage Plan/Agreement on file with the White County Surveyor.

7.14 POST-CONSTRUCTION REQUIREMENTS

Post-construction, the applicant shall comply with the following provisions:

7.14.1 Road Repairs

Any road damage caused by the construction of project equipment, the installation of the same, or the removal of the same, shall be repaired as per the Road Use and Maintenance Agreement approved by the County Commissioners. The White County Highway Superintendent may choose to require either remediation of road repairs upon completion of the project or is authorized to collect fees for oversized load permits. Further, a corporate surety bond in an amount to be fixed by a professional engineer may be required by the White County Highway Superintendent to insure the County that future repairs are completed to the satisfaction of the unit of local government. The cost of bonding is to be paid by the applicant.

7.14.2 As-Built Plans Requirement

Where upon completion of all development, the exact measurements of the location of utilities and structures erected during the development are necessary for public record and shall therefore be recorded. The applicant, owner, developer or operator shall submit a copy of the Final Construction Plans (as-built plans), as amended, to the Area Plan Department with the exact measurements thereon shown. The Area Plan Department Executive Director, after being satisfied that the measurements are substantially the same as indicated on the originally approved final plan(s), shall approve, date and sign said Construction Plans for the project, which the applicant, owner, developer or operator shall then record.

7.14.3 Change in ownership

It is the responsibility of the owner, developer or operator listed in the application to inform the Area Plan Staff of all changes in ownership and operation during the life of the project, including the sale or transfer of ownership or operation.

7.15 COMMERCIAL, INDIVIDUAL AND SHARED SOLAR ENERGY SYSTEMS ***

7.15.1 Purpose, Persons Liable, Authority, Scope and Exclusions & Exemptions

A. Purpose

This section is established in order to protect the public health, safety and general welfare of the community while accommodating the production and energy objectives associated with solar energy efforts. As such, it is necessary to regulate the use, construction and modification of Individual Solar Energy Systems (ISE), Shared Solar Energy Systems (SSE) and Commercial Solar Energy Systems (CSE). This section works to avoid the adverse impacts of such operations on the community and the area's natural and constructed resources while still accommodating the need for solar energy production.

B. Persons Liable

The property owner and developer have the duty of compliance with the requirements of this Chapter and any other requirements provided for in this Ordinance pertaining to ISE, SSE and CSE developments.

C. Authority

Area Plan Department Staff are hereby vested with the authority to review and approve or deny applications for ISE, SSE and CSE developments as well as for modifications, alterations, upgrades, maintenance (other than routine maintenance) or revisions to these developments under the direction of the Area Plan Executive Director.

D. Scope

Section 7.15 applies to all ISE, SSE and CSE developments as defined in Chapter 14, Definitions. Nothing in this Chapter or Ordinance is intended to preempt other applicable State and/or Federal Laws or regulations pertaining to solar energy development. Where a conflict occurs between this Chapter and any other requirements of the White County Indiana Zoning Control Ordinance, this Chapter shall prevail.

E. Exclusions and Exemptions

A permit is not required for the following:

1. Any ISE or SSE which does not include in excess of one hundred twenty (120) square feet of solar panel face.
2. Any work which constitutes "routine maintenance" of an ISE, SSE or CSE. Routine maintenance includes, but is not limited to, the following:
 - a. repair of ISE, SSE or CSE components and/or system infrastructure; and/or,
 - b. replacement of components and/or infrastructure with those of the same nature and the same physical size and/or power strength; and/or,
 - c. such other maintenance and/or repair work determined to be routine in nature by the Executive Director.

Also excluded from permit requirements are high-tension power lines, electrical transmission towers, transformers, utility owned substations or utility poles used to connect an ISE, SSE or CSE to a utility system's infrastructure.

F. Other

1. ISE, SSE and CSE developments are exempt from the requirements of Chapter 8 Parking and Loading.
2. ISE, SSE and CSE developments shall meet all applicable State, Local and Federal regulatory codes in addition to the requirements of this Ordinance.

3. ISE, SSE and CSE developments shall be constructed to meet or exceed National Electric Safety Codes.

7.16 APPLICATION REQUIREMENTS

For purposes of this section, the term “application” refers to an Improvement Location Permit (ILP) application along with any other documents required by this Ordinance, this Chapter or which are requested by the Area Plan Staff. Unless specifically exempted by this Chapter, no construction or development of an ISE, SSE or CSE may be initiated without first obtaining an ILP from the Staff and, if required, a Building Permit. All structures (except signage) for the proposed developments may be covered by a single application. Signage for the development must satisfy the requirements of this Chapter as well as the standards of Chapter 10 of this Ordinance and are subject to a permit application process separate from that of the ISE, SSE or CSE physical development application.

A. Application Documents – CSE

The following application documents reflect the minimum amount of information which must be provided for a CSE development:

1. An ILP Application along with the associated application filing fee. This application must be signed by the property owner or developer (if signed by the developer, the developer must provide a properly executed lease agreement or notarized letter from the property owner authorizing the proposed development);
2. A Site Plan which satisfies the content requirements of Chapter 12, Section 12.13, Subsection 12.13.5;
3. Scope of Work & Project Identification
 - a. Contact information – The names, addresses and phone number(s) of all applicants, project owner(s), project developer and project operator;
 - b. Legal description and map of the project area;
 - c. Project description including the number of arrays and their configuration, name plate generating capacity, potential equipment manufacturers, means of connecting to the electrical grid and a site layout plan drawn to appropriate scale (site requirements may be delineated on multiple pages);
4. Engineering certification that the foundation is designed within accepted professional standards given local soil and climate conditions
5. A letter from the respective legislative body certifying that an Economic Development Agreement has been approved by said legislative body
6. Presentation of a fully executed Decommissioning Plan approved by the respective legislative body

7. A letter from the respective legislative body that a Road Use and Road Maintenance Agreement has been approved or that a waiver from such has been granted
8. An approval letter or approved permit of development from the Federal Aviation Administration if any part, piece or component of the CSE penetrates navigable airspace as defined by the Federal Aviation Administration's rules, regulations and guidelines;
9. Delineation of compliance to the requirements of Appendix B Bulk Use Standards
10. Delineation of compliance to all developmental standards provided within this Chapter
11. A letter from the County Surveyor that a drainage plan has been approved or requirement waived by the County Drainage Board
12. A vegetation plan in compliance with subsection 7.17 B. 10. of this Chapter
13. Compliance to screening requirements established by subsection 7.17 B. 8. of this Chapter
14. Certification from an independent, industry, design professional or licensed engineer that the proposed development will not create undue glare or reflection so as to create a traffic hazard or cause a nuisance to neighboring properties; this Certification must clearly delineate all steps taken to mitigate such circumstances; and
15. Any other item reasonably requested by the Area Plan Staff.

B. Application Documents – ISE, SSE

The following application documents reflect the minimum amount of information which must be provided for an ISE or SSE development:

1. ILP Application along with the associated application filing fee. This application must be signed by the property owner or developer;
2. Site Plan which satisfies the content requirements of Chapter 12, Section 12.13, Subsection 12.13.5;
3. Letter of Development Approval from the Federal Aviation Administration, if any part, piece or component of an ISE or SSE penetrates navigable airspace as defined by the Federal Aviation Administration's rules, regulations and guidelines. This may come in the form of an aeronautical study approval;
4. Delineation of compliance to the requirements of Appendix B Bulk Use Standards;
5. Delineation of compliance to all developmental standards provided within this Chapter.

7.17 DISTRICT REGULATIONS AND PERFORMANCE STANDARDS

A. Location

1. ISE, SSE and CSE developments will be allowed or not allowed as prescribed by the Official Schedule of Uses (Appendix A). At no time will an ISE, SSE or CSE be allowed in a regulated floodway, flood fringe, regulated wetland or designated conservation or wildlife area without approval from the White County Floodplain Administrator or the Area Plan Executive Director.

B. Size, Height, Setbacks and Other Developmental Standards – CSE

1. All structures shall conform to the standards for principal structures as provided by the Bulk Use Chart (Appendix B) of the zoning district classification for which the development is proposed or to the more restrictive or alternate standard provided for in this Chapter;
2. Utility infrastructure, including support structures for overhead wiring connecting a CSE system to said infrastructure are exempt from the Bulk Use Standards provided for in Appendix B Bulk Use Chart as well as those standards within this Chapter;
3. Any CSE project must have a minimum project area of at least five (5) acres; a project area may consist of multiple parcels, either contiguous or separated only by a road or alley, of which individual parcels may be less than five (5) acres;
4. Any CSE project must have a minimum nameplate capacity of ten (10) megawatts;
5. All solar arrays along with their associated support structures must be ground based not to exceed twenty-five (25) feet in height when the panels are in full tilt and as measured from the surrounding average grade;
6. A CSE system compound may be located no closer than forty (40) feet to the nearest edge of any federal interstate highway, federal highway, state highway or county highway right-of-way; thirty (30) feet to the nearest edge of any collector road right-of-way or ten (10) feet to the nearest edge of any local road right-of-way (these setbacks do not apply to the infrastructure required to distribute electricity to the electrical grid or an associated substation);
7. No perimeter point of a CSE system compound may be closer to a project area property line than fifty (50) feet. This setback requirement may be waived with the written consent of the effected property owners; either Participating or Non-Participating property owners;
8. A CSE system compound may be no closer than one hundred-fifty (150) feet to the nearest point of the outer wall of a dwelling on a non-participating owner's property, subject to installation of a landscape buffer as provided for in subsection 7.17. B. 8 (a) of this Chapter. The landscape buffer requirement of this subsection is hereby waived if the outer edge of the CSE system compound is at least two hundred fifty (250) feet away

from the nearest point of the outer wall of the subject dwelling. The landscape buffer may be waived with the written consent of the non-participating property owner;

9. Screening shall be provided along any segment of a CSE project property line abutting a residential zoning district. In addition, where a residential district lies across the road from a property included in a CSE project area, the portion of the CSE project area property line directly across from the residential district property line, plus an extension of twenty (20) feet along said CSE project area property line, in each direction, shall be screened. These screening requirements are hereby waived should a CSE system compound be no closer than two hundred-fifty feet to the residential district property line. Also, these screening requirements may be waived with the written consent of the affected property owner. Required screening shall meet the following standards:
 - a. Screening may be in the form of a berm or be vegetative in nature (vegetative screenings are preferred) and located between the property line or right-of-way line (whichever is most restrictive) and the security fence (however, no screening shall violate a visual clearance area as provided for in Chapter 3, Subsection 3.07);
 1. If vegetative;
 - a. There shall be a minimum of two (2) rows of planting; the plantings in each row shall be no more than every twenty-five (25) feet apart; the rows shall be separated by no less than six (6) feet and no more than twenty-five (25) feet;
 - b. plantings must reach a minimum height of six (6) feet within two (2) years after planting;
 - c. plantings may be of any variety determined appropriate by the project owner, developer or operator.
 2. If a berm;
 - a. the berm shall have a maximum slope of 3:1;
 - b. be a minimum height of six (6) feet tall
 - c. be a maximum height of ten (10) feet tall; and,
 - d. shall be entirely vegetated with ground cover.

Note: For the purposes of Chapter 7 of this Ordinance, a private road does not include driveways, interior service roads or temporary ingress/egress drives or roads constructed and utilized only for the purpose of a solar energy development or which are intended solely for the purpose of maintaining a solar energy system.

10. Vegetation Plan or Agricultural Plan submission: Each CSE project shall provide a Vegetation Plan or an Agricultural Plan with their application. A Vegetation Plan shall include a perennial vegetated ground cover over all land, including around and under solar panels, not improved with a gravel,

concrete or paved surface. This plan is to be maintained for the life of the project and provide for the use of non-invasive and native or naturalized species. Incorporation of pollinator friendly seed mixes is encouraged but not required. The plan must include the details for site preparation and maintenance practices designed to control invasive species and noxious weeds. An Agricultural Plan shall include a narrative of the type of agricultural activities which are to take place, the area of land to be made available for such activities and the name and contact information of the party(ies) with whom an agricultural agreement has been reached along with a copy of such agreement. Any land area not captured within the Agricultural Plan must meet the Vegetation Plan requirements listed above;

11. A CSE may not produce in excess of an hourly average sound level of fifty (50) A-weighted decibels as modeled at the closest outer wall of a dwelling located on any adjacent, Non-Participating property. The sound level maximum may be waived with the written consent of the Non-Participating property owner;
12. The land area of any CSE system compound shall not be counted toward the lot coverage maximum as provided for in Appendix B Bulk Use Chart for the applicable zoning district of the subject site;
13. All CSE projects must provide security fencing around the outer edge of each CSE system compound in addition to any screening requirements stipulated in Subsection 7.17. B. 8 of this Chapter. Said fencing must provide limited and secured access to prevent entry by unauthorized personnel. Fencing and access gates shall be between six (6) and ten (10) feet tall as measured from the ground grade to the top of the fencing material (post excluded). Note: When a CSE system project area is divided into sections as a result of roads/streets, alleys, easements or similar restricted areas, each CSE system compound within each section is subject to the security fencing requirements of this subsection;
14. All cables between banks of solar panels and the CES solar collection electric substations and operations & maintenance buildings shall be buried underground at a depth of at least thirty-six (36) inches below grade;
15. A CSE system must be designed and constructed to:
 - a. Minimize glare on adjacent properties and roadways; and,
 - b. Not interfere with vehicular or air traffic; no fence or structure may be placed in a visual clearance area as provide for in Chapter 3, Section 3.0.7.
16. A CSE project owner or developer must provide certification that the CSE system will not interfere with:
 - a. Television signals
 - b. Microwave signals
 - c. Agricultural global positioning systems

- d. Military defense radar
 - e. Radio reception; or,
 - f. Weather and doppler radar.
17. A CSE project area may not be located within one-half (1/2) mile of any municipality boundary line or GIS boundary line for Buffalo or Idaville. This limitation may be waived, in part or in full, with the written consent of the effected legislative body;
 18. The solar energy project owner or developer must provide a certification of acknowledgement that they are aware and accept liability for all damages to County regulated waterways, drainage, ditches, field tiles or other drainage related infrastructure caused by the construction, installation or maintenance of a solar energy project and such infrastructure must be repaired by the project owner to near original condition so as not to impede the flow of water as it existed in its pre-damaged state. All repairs must be made in a reasonable time and to the satisfaction of the unit and as stated in an applicable lease or other agreement with the landowner subject to applicable federal, state and local drainage laws and regulations;
- C. Size, Height, Setbacks and Other Developmental Standards – ISE, SSE
1. All ISE and SSE components will be treated as Accessory Structures for the purposes of applying Bulk Use Chart (Appendix B) standards unless a more restrictive or alternative standard is provided for in this Chapter;
 2. Screening shall be provided in accordance with Subsection 7.17 B. 9a) 1. along each section of property line where any solar energy component (excluding roof-top solar installations), is located within twenty (20) feet of a property boundary line abutting a residential district. The screening requirements may be waived or modified by the effected property owner if said effected property owner submits, in writing, agreement to waive or modify the screening requirements
 3. Ground Mount Solar Installations;
 - a. All Solar Panels and/or Solar Arrays, as well as the Panel or Arrays underlying framework, shall be a minimum of three (3) feet above ground level as measured from any ground point to the closest point of any solar panel when positioned at the panels most vertical, functioning position; this requirement may be modified or waived by the Executive Director if, in the sole opinion of the Executive Director, the modification or waiver request serves the communities best interest or is unable to be met with minor design alterations; and,
 - b. All ISE/SSE Ground Mount Systems shall be located in a side or rear yard or twenty (20) feet behind a required front setback.

Note: No area of the solar energy system compound shall be counted toward the lot coverage maximum as provided for in Appendix B Bulk Use Chart for the applicable zoning district of the subject site.

4. Roof Top Installations:

Note: Installations using solar shingles designed to serve as a final roof covering are exempt from the requirements of “a” thru “e” below

- a. Solar Panels and/or Solar Arrays shall be separated above the roofing material a minimum of the distance recommended by the panel/array/equipment manufacturer. If the manufacturer does not provide a separation recommendation, then all solar panels and/or solar arrays must be a minimum of four (4) inches and a maximum of eight (8) inches above the roofing material to the bottom of the solar panel;
- b. Solar Panels, Solar Arrays and/or installation framing & bracketry must be mounted so that no edge of any Solar Panel, Solar Array and/or installation framing & bracketry extends beyond the vertical plane of the exterior walls of a building (the eave line);
- c. For roof planes with thirty-three (33) percent or less panel coverage, panels may not extend any closer than eighteen (18) inches to a roof ridge; for roof planes which exceed thirty-three (33) percent coverage, panels may not extend any closer than 36 inches to a roof ridge. For panels mounted on roof tops considered to be flat (two units vertical in twelve units horizontal or less), a thirty-six (36) inch setback from the roof perimeter is required;
- d. Maximum panel coverage for any roof plane is seventy-five (75) percent. For purposes of this Chapter, a roof plane is each continuously flat section of roof whose perimeter is defined by a roof ridge and a series of roof edges or valleys. ;
- e. Excluding a roof top defined as flat under (c) of this subsection, each roof top installation is required to include a minimum of two pathways. Pathway requirements are as follows:
 - i. Pathways must extend from the bottom roof line (roof line closest to the ground) to the ridge line;
 - ii. At least one pathway must be on the roof plane that most closely aligns with the street or driveway;
 - iii. Pathways must be thirty-six (36) inches wide on a single roof plane or, on adjacent roof planes, eighteen (18) inches wide on each side of a roof ridge or valley;
 - iv. At the time of application, the applicant must provide a certification that each pathway will be over areas able to support firefighters and be located in areas without obstructions, including, but not limited to, vent pipes, chimneys, conduit and mechanical equipment.

- f. All solar panel installations require an engineering certification provided at the time of application confirming that the structural integrity of the roof is capable of handling the additional roof load.
 - g. All solar panel installations must include a rapid shutdown disconnect switch. This must be located within two (2) feet of the main electrical meter base for the structure.
5. Tree Style Solar Arrays are allowed only with the approval of the Area Board of Zoning Appeals and the petitioner must demonstrate to the Board that the tree(s) installation will not create a safety hazard or nuisance to any near-by (within one-quarter (1/4) mile) property owner or the community at large.
6. Floating Solar Installations are allowed only with the approval of the Area Board of Zoning Appeals. It is the responsibility of the petitioner to demonstrate compliance with the White County Indiana Zoning Control Ordinance, Appendix E Regulations for Flood Hazard Areas and all Federal, State or Local laws, codes and regulations as well as demonstrate that the installation will not create any community or site safety issues or security vulnerabilities. The property owner or solar energy project developer shall provide written documentation outlining the steps taken to mitigate any potential nuisance factors.
7. For purposes of an SSE designed to provide energy to buildings on abutting properties, the SSE is not required to meet setback or screening requirements from property lines which are common to any properties included within the intended service group.

7.18 COMMERCIAL SOLAR ENERGY SYSTEM'S COLLECTION AND TRANSMISSION SYSTEM

A. CSE System's Substation

For all Substations, setbacks from property lines are waived if the affected adjoining landowners sharing the common property line are all Participating Landowners.

B. Poles

For all poles carrying overhead wiring connecting a CSE system to a Substation for connection to a utility's electric transmission line, there are no setback requirements from property lines as long as the poles are located within a recorded easement for such purpose.

7.19 BATTERY STORAGE FIELDS AND BATTERY STORAGE RETROFITS

All Utility Scale Battery Energy Storage Systems (USBESS), an energy storage system that is capable of storing and releasing more than one (1) megawatt of electrical energy for a minimum of one (1) hour using an AC inverter and DC storage, are subject to regulations under IC 22-14-8, as amended from time to time, and which are required to

follow the National Fire Protection Association (NFPA) 855. standard Those facilities must provide a copy of a permit issued by Homeland Security along with any other applications, documents or submissions required by this section.

All facilities covered under IC 22-14-8, must provide a copy of the applicant's emergency response plan for responding to a fire at or discharge or threatened discharge of environmental contaminants by the USBESS as well as the approved plan for emergency response training.

All Battery Storage Fields or Battery Storage Retrofits, regardless of whether being subject to IC 22-14-8 or not, must meet the requirements provided in this Chapter.

For either a Battery Storage Field or a Battery Storage Retrofit, an Improvement Location Permit Application, a site plan, any other documents associated with the application along with permit fees must be submitted prior to placement or incorporation of Battery Storage units.

Battery Storage units which are incorporated into the original commercial wind or solar energy project application are exempt from the requirements of this Section and are to satisfy the requirements, regulations and development standards demanded by the respective sections and subsections elsewhere in this Chapter.

Unless meeting the exemption listed earlier in this section, all Battery Storage Fields or Battery Storage Retrofit projects must meet the respective requirements, regulations and development standards detailed below as well as any other standards, regulations or requirements applicable elsewhere in this Ordinance:

A. Battery Storage Retrofits

1. Battery Retrofits to an existing wind energy or commercial solar energy system project and designed for placement and use within an approved CSE or WECS project compound must comply with the following:

- a. Submission of an approved, counter signed Economic Development Agreement from the respective legislative body or proof from that body that a waiver from this requirement has been granted;
- b. Submission of an approved, counter signed Decommissioning Plan from the respective legislative body or proof from that body that a waiver from this requirement has been granted;
- c. Submission of an approved, counter signed Road Use and Road Maintenance Agreement from the respective legislative body or proof from that body that a waiver from this requirement has been granted;

- d. A letter from the County Surveyor that a drainage plan has been approved or requirement waived by the County Drainage Board; and,
 - e. Any other item reasonably requested by the Area Plan Staff.
2. Battery Retrofits To Existing Wind Energy or Commercial Solar Energy Systems and designed for placement and use outside an approved project compound must satisfy the same application requirements and district regulations & performance standards as a Battery Storage Field.

B. Battery Storage Field (BSF)

1. The following application documents reflect the minimum amount of information which must be provided for a Battery Storage Field.
 - a. An ILP Application along with the associated application filing fee. This application must be signed by the property owner or developer (if signed by the developer, the developer must provide a properly executed lease agreement or notarized letter from the property owner authorizing the proposed development);
 - b. A Site Plan which satisfies the content requirements of Chapter 12, Section 12.13, Subsection 12.13.5 or as approved by the Executive Director;
 - c. Scope of Work & Project Identification
 - (1) Contact information – The names, addresses and phone number(s) of all applicants, project owner(s), project developer and project operator;
 - (2) Legal description and map of the project area; and,
 - (3) Project description including the number of Battery Housings and their configuration, storage capacity, means of connecting to the electrical grid and a site layout plan drawn to appropriate scale (site

requirements may be delineated on multiple pages);

- d. Submission of an approved, counter signed Economic Development Agreement from the respective legislative body or proof from that body that a waiver from this requirement has been granted;
- e. Submission of an approved, counter signed Decommissioning Plan from the respective legislative body or proof from that body that a waiver from this requirement has been granted;
- f. Submission of an approved, counter signed Road Use and Road Maintenance Agreement from the respective legislative body or proof from that body that a waiver from this requirement has been granted;
- g. Delineation of compliance to the requirements of Appendix B Bulk Use Standards;
- h. Delineation of compliance to all developmental standards provided within this Chapter;
- i. A letter from the County Surveyor that a drainage plan has been approved or requirement waived by the County Drainage Board;
- j. Compliance to screening requirements established by subsection 7.17 B. 8. of this Chapter;
- k. Any other item reasonably requested by the Area Plan Staff.

7.20 DISTRICT REGULATIONS AND PERFORMANCE STANDARDS FOR BATTERY STORAGE FIELDS (BSF)

A. Location

1. Battery Storage Fields will be allowed or not allowed as prescribed by the Official Schedule of Uses (Appendix A). At no time will BSF improvements be allowed in a regulated floodway, flood fringe, regulated wetland or designated conservation or wildlife area without approval from the White County Floodplain Administrator or the Area Plan Executive Director. If located within one-half (1/2) mile of a one hundred (100) year flood plain as determined by the most recent Federal Emergency Management Agency (FEMA) Flood Insurance Rate Maps, all of the system's equipment must be located at least two (2) feet above the one-hundred (100) year frequency flood elevation.

B. Size, Height, Setbacks and Other Developmental Standards

1. All structures shall conform to the standards for principal structures as provided by the Bulk Use Chart (Appendix B) of the zoning district classification for which the development is proposed or to the more restrictive or alternate standard provided for in this Chapter;
2. Utility infrastructure, including support structures for overhead wiring, which connect Battery Storage units to said infrastructure are exempt from the Bulk Use Standards provided for in Appendix B Bulk Use Chart as well as those standards within this Chapter;
3. Any BSF project must have a minimum project area of at least five (5) acres; the minimum five (5) acres may be a stand-alone parcel or a portion of a larger parcel of which five (5) or more acres are leased;
4. No perimeter point of a BSF compound may be closer to a project area property line than thirty (30) feet;
5. Screening shall be provided along any segment of a BSF project area property line abutting a residential zoning district. In addition, where a residential district lies across the road from a property included in a BSF project area, the portion of the BSF project area property line directly across from the residential district property line, plus an extension of twenty (20) feet along said BSF project area property line, in each direction, shall be screened. These screening requirements are hereby waived should a BSF compound be no closer than two hundred-fifty feet to the residential district property line. Also, these screening requirements may be waived with the written consent of the affected property owner(s). Required screening shall meet the following standards:
 - a. Screening may be in the form of a berm or be vegetative in nature (vegetative screenings are preferred) and located between the property line or right-of-way line (whichever is most restrictive) and

the security fence however, no screening shall violate a visual clearance area as provided for in Chapter 3, Subsection 3.07;

1. If vegetative;
 - a. There shall be a minimum of two (2) rows of plantings; the plantings in each row shall be no more than every twenty-five (25) feet apart; the rows shall be separated by no less than six (6) feet and no more than twenty-five (25) feet;
 - b. plantings must reach a minimum height of six (6) feet within two (2) years after planting;
 - c. plantings may be of any variety determined appropriate by the project owner, developer or operator.
2. If a berm;
 - a. the berm shall have a maximum slope of 3:1;
 - b. be a minimum height of six (6) feet tall
 - c. be a maximum height of ten (10) feet tall; and,
 - d. shall be entirely vegetated with ground cover.

Note: For the purposes of Chapter 7 of this Ordinance, a private road does not include driveways, interior service roads or temporary ingress/egress drives or roads constructed and utilized only for the purpose of supporting installation, servicing or monitoring of BSF unit.

6. A BSF may not produce in excess of an hourly average sound level of fifty (50) A-weighted decibels as modeled at the closest outer wall of a dwelling located on any adjacent, Non-Participating property. The sound level maximum may be waived with the written consent of the Non-Participating property owner;
7. The land area of any BSF compound shall not be counted toward the lot coverage maximum as provided for in Appendix B Bulk Use Chart for the applicable zoning district of the subject site;
8. All BSF projects must provide security fencing around the outer edge of each compound in addition to any screening requirements stipulated in Subsection 7.19. B. 5 of this Chapter. Said fencing must provide limited and secured access to prevent entry by unauthorized personnel. Fencing and access gates shall be between six (6) and ten (10) feet tall as measured from the ground grade to the top of the fencing material (post excluded). Note: When a BSF project area is divided into sections as a result of roads/streets, alleys, easements or similar restricted areas, each BSF compound within each section is subject to the security fencing requirements of this subsection;
9. All cables between Battery Storage units and the associated renewable energy development as well as the electric substation and operations &

maintenance buildings shall be buried underground at a depth of at least thirty-six (36) inches below grade. The applicant may request waiver from this requirement. Such waiver must be in writing and addressed to the Area Plan Executive Director, who, at his/her sole discretion may waive such requirement if, in his/her sole opinion, proper justification is made;

10. A BSF project area may not be located within one-half (1/2) mile of any municipality boundary line or GIS boundary line for Buffalo or Idaville. This limitation may be waived, in part or in full, with the written consent of the effected legislative body;
11. The BSF project owner or developer must provide a certification of acknowledgement that they are aware and accept liability for all damages to County regulated waterways, drainage, ditches, field tiles or other drainage related infrastructure caused by the construction, installation or maintenance of a solar energy project and such infrastructure must be repaired by the project owner to near original condition so as not to impede the flow of water as it existed in its pre-damaged state. All repairs must be made in a reasonable time frame and to the satisfaction of the unit and as stated in an applicable lease or other agreement with the landowner subject to applicable federal, state and local drainage laws and regulations.

CHAPTER 8 PARKING AND LOADING STANDARDS

8.0 PURPOSE AND INTENT

The regulations of this Chapter are designed to alleviate or prevent congestion of public streets and other traffic hazards by establishing minimum requirements for off-street parking, loading and storage of motor vehicles, trailers & recreational vehicles. An Improvement Location Permit is required for any new parking lot or any parking lot refurbishment; i.e., resurfacing, restriping, modification or expansion.

8.1 GENERAL STANDARDS

8.1.1 Minimum parking and loading requirements

In the event that the minimum parking requirements established by this Ordinance are less restrictive than what was previously required, it shall not be necessary to restore or maintain parking or loading facilities in excess of those required by this Ordinance.

8.1.2 Parking and loading for uses which have been intensified

When the intensity of an existing use of any building, structure, or premises is increased through the addition of dwelling units, floor area, beds, seating capacity, or other unit of measurement, additional parking and loading facilities shall be provided to accommodate the increase in intensity of use only and the lot shall be brought into compliance with the ADA requirements of this Chapter.

8.1.3 Parking and loading for buildings which have been converted

When the existing use of a building, structure or premises is changed or converted to a new use, parking and loading facilities shall be provided as required for the new use, provided that the new use is permitted by this Ordinance.

8.1.4 Reduction in existing parking and loading facilities

Parking and loading facilities in existence on the effective date of this Ordinance shall not be reduced below, or if already less than, shall not be further reduced below, the requirements for the existing use as prescribed by this Chapter.

8.2 APPLICABILITY

All uses of land except those used for amusement park purposes and located within an AED, Amusement and Entertainment, district or uses within a B-4, General Business Dense Development District, must include on-site parking and loading in accordance with all standards of this Chapter. All uses of land within an AED or B-4 District that provide off-street parking must comply with the ADA requirements of this Chapter, including obtaining an Improvement Location Permit.

8.2.1 On-Street Parking

On-street parking is exempt from the Parking Standards outlined in this Chapter with the exception that all on-street parking shall meet ADA requirements and general parking standards as established by the applicable legislative body; and provided that all on-street parking also meets the requirements of any Federal or State entity which prevails in jurisdiction for on-street parking standards.

8.2.2 Location of accessory off-street parking and loading facilities

Accessory off-street parking and loading spaces are expected to be provided on the same lot as the associated use, except in cases where an entity or entities qualify to utilize shared parking as provided in Section 8.4 of this Ordinance or as provided in the paragraph below.

In any non-residential use of property, any property owner may use an associated lot to help satisfy the parking requirements and needs of the principal use lot (the lot upon which the principal use activity occurs) as long as there is at least one boundary line of the associated lot within three hundred sixty (360) feet of a boundary line of the principal use lot and there are no residential district areas in-between the two. If the parent parcel and the associated parcel have a common property line, they must be combined into a single parcel before a permit shall be issued.

Parking lots may be designed and constructed in a manner which creates more than one (1) parking area (a sectionalized parking lot) as long as all ADA requirements are satisfied.

8.2.3 Off-street parking facilities - prohibition

No required parking facility shall be used for the storage, display, sale, repair, dismantling, or wrecking of any vehicle, equipment, or material.

8.2.4 Sharing of off-street parking facilities

No parking space or any portion thereof shall serve as a required space for more than one (1) use unless otherwise provided for by this Chapter or authorized by the Area Board of Zoning Appeals. Off-street parking facilities intended for separate uses may be maintained collectively so long as the total number of spaces is not less than the sum of the separate requirements for each use or as otherwise provided for in this Chapter, provided that the property complies with all other applicable regulations governing the location of parking spaces for said uses.

8.2.5 Off-street loading and unloading spaces as they relate to required off-street parking

No required off-street loading and unloading space shall be construed as being part of the required off-street parking spaces.

8.2.6 Exception for loading and unloading berths

No loading and unloading berth shall be required for a business use or industrial use which demonstrably does not receive or transmit goods or wares by semi-truck delivery.

8.3 EXISTING PARKING & LOADING AREAS

8.3.1 Use of existing parking and loading areas

No use lawfully established prior to the effective date of this Ordinance shall be required to provide and maintain the parking and loading requirements of this Section, provided that the existing parking and loading spaces are continued and maintained in good condition. However, any such parking lot resurfaced, restriped, modified or expanded must meet the ADA requirements of this Chapter.

8.3.2 Parking and loading areas damaged or destroyed

Any legal or legally nonconforming parking and/or loading area where damage or destruction occurs which is 50% or less of the total parking/loading area, may be reconstructed, re-established or repaired as was prior to the damage or construction as long as such reconstruction, re-establishment or repair occurs within one year from the initial date of damage or destruction. However, in any such instance, regardless of the level of damage or destruction, the parking/loading area must be brought into compliance with the ADA requirements of this Chapter.

Any legal or legally nonconforming parking and/or loading area where damage or destruction occurs and which incurs over 50% of the parking area damaged or destroyed, shall be reconstructed, re-established or repaired in accordance with the requirements of this Chapter.

8.3.3 Parking and loading areas servicing damaged or destroyed conforming or legally nonconforming buildings or structures

Any site where 50% or less of the total gross area for buildings and structures is damaged or destroyed, shall be allowed to retain the parking and loading areas as existed prior to the damage or destruction occurrence, subject to 8.3.2.

Any building or structures damaged or destroyed by more than 50% of the total gross area for buildings and structures located on the applicable site, shall be required to modify or reconstruct parking in compliance with the requirements of this Chapter or, if determined by the Executive Director full compliance cannot be practically achieved, shall modify or reconstruct parking as fully as practical as determined by said Director.

8.4 SHARED PARKING

8.4.1 Shared parking for uses with similar hours of operation

Cooperative provisions for off-street parking may be made by contract between two (2) or more adjacent property owners, provided that the minimum parking requirements for any participating use are not reduced to less than one-half (1/2) the number of required parking spaces for said participating use.

8.4.2 Shared parking for uses which operate at different hours of the day

To the extent that developments wish to make joint use of the same parking spaces operating at different times, up to one-half (1/2) of the parking spaces may be

Amended 03/21/2022: Ordinance No. 22-03-21-01

credited to both uses if one (1) of the uses is a church, theater, or assembly hall whose peak hours of attendance will be at night or on weekends, and the other use or uses are ones that will be closed at night or on weekends. The Executive Director may allow, at his sole discretion, the counting of parking spaces for more than one use should the uses not have an overlap in hours of operation or should a site have excess spaces in accordance to the site's use. In such instances where the volume of business or use allows, shared parking can be authorized by the Executive Director. The request and subsequent authorization, if granted, for shared parking spaces must be provided in writing.

8.4.3 Shared Parking, Temporary Uses

Any temporary use for which a temporary use permit is required may utilize a common parking lot with the principal use as long as the temporary use can demonstrate that it will not require more than ten (10) percent of the parking lot spaces available in the lot, including any spaces consumed by facilities and/or vehicles of the temporary use, and that the proposed parking for the temporary use will not create a nuisance or unsafe condition. Temporary uses may only use parking areas in compliance with this Chapter. The available parking for the temporary use must satisfy all State, Local and Federal ADA Standards.

8.5 PARKING SPACES ACCESSIBLE TO THE DISABLED

White County requires all development within its jurisdiction that serves the public to provide facilities that are accessible to people with disabilities as defined by the Americans with Disabilities Act (ADA) of 1990, as amended from time to time and in compliance with Title II of the ADA. ADA accessible parking shall be provided for any public building or use initiated after the effective date of this Ordinance or in the case where a parking lot refurbishment occurs that involves resurfacing, restriping, modification or expansion. All such development shall comply with the 2005 Guidelines for Accessible Public Rights of Way and the 2010 American with Disabilities Act Standards for Accessible Design and any standard changes or updates required by future changes to Title II of the ADA. All ADA accessible parking shall be in conformance with the following minimum requirements and any further requirements hereafter adopted by federal, state, or local law.

8.5.1 Required spaces

Accessible parking spaces shall be provided at the rate prescribed by Table 8.1, Parking Spaces Accessible to the Disabled. In addition to these requirements, uses with accessible patient parking at outpatient facilities must equal no less than ten percent (10%) of the required parking, and facilities which specialize in treatment or services for persons with mobility impairments shall provide accessible parking equaling no less than twenty percent (20%) of the required parking for patient use.

A minimum of one (1) van accessible space is required for all sites. Sites which require sixteen (16) accessible spaces or more, one (1) van accessible space shall be incorporated into the parking area for each six (6) accessible parking spaces required.

Amended 03/21/2022: Ordinance No. 22-03-21-01

For ADA parking space calculations, two (2) motorcycle half spaces equals one standard parking space, the total of which is added to the parking space total. Each golf cart space counts as a full space toward establishing the ADA parking space requirements.

8.5.2 General ADA design and layout requirements

Access aisles and accessible routes for the mobility impaired shall be provided pursuant to the requirements of this Chapter in addition to any and all ADA requirements as amended from time to time.

ADA has various access route requirements depending on the use of the site. Access routes must be provided as specified by the use in accordance with ADA standards as amended from time to time.

Any access route located in front of a Handicapped spot must install a wheel stop to keep vehicles from reducing the route width to below thirty-six (36) inches.

All access aisles must be level to a maximum of one to fifty (1:50) slope in all directions.

Any van accessible space, access aisle or vehicular route to and from a van space must provide a minimum of ninety-eight (98) inches of clearance.

Each ADA parking space shall be a minimum of nine (9) feet wide and twenty (20) feet in length.

Each ADA parking space shall include an adjacent access aisle as follows: All standard accessible aisles must be a minimum of five (5) feet in width; All van accessible aisles must be a minimum of eight (8) feet in width.

A universal parking space design may be used if applied to all ADA required parking spaces. Universal spaces measure a minimum of eleven (11) feet in width with a minimum five (5) foot access aisle.

ADA parking spaces may utilize a common access aisle.

In cases where a van accessible space and standard space are designed to share an aisle and laid out in ninety (90) degree fashion, the Van Accessible space is to be the one which puts the passenger side of the van next to the access aisle.

Access aisles must be adjacent to the designated parking space. No ramp, bollard or other object shall be placed in or occupy any portion of an access aisle.

No accessible route shall have a curb or stair and must be at least three (3) feet wide pitched no greater than 1:12 in the direction of travel. The surface must be firm, stable and slip resistant.

8.5.3 Design Deviation

Any person or entity may request a design deviation from the ADA requirements upon demonstration to the Executive Director that it is structurally impractical to comply with the requirements of this Chapter or that a Federal Standard is more applicable to site conditions. Any design deviation granted must be granted in

writing and shall only provide the minimum amount of relief necessary and require compliance to the fullest extent possible.

Any deviation granted may allow parking within a setback in order to meet the requirements of this Chapter, but never closer than five (5) feet to any property or right-of-way line.

Departures from particular requirements of this Chapter require approval in writing from the Executive Director and shall only be granted where the alternative(s) will provide substantially equivalent or greater access to and from usability of the facility.

Certain exemptions and additions to ADA requirements and this Chapter are applicable for specific uses as provided for in ADA guidelines. Reference the Americans with Disabilities Act Accessibility guidelines for identification of relief or requirements based on specific use.

8.5.4 ADA loading zones

- A. Passenger Loading: ADA passenger loading zones shall provide an access aisle a minimum of five (5) feet wide and a minimum of twenty (20) feet in length, adjacent and parallel to the vehicle pull up space. If there are curbs between the access aisle and the vehicle pull up space, then a curb ramp shall be installed and maintained in good condition.
- B. Vending Loading Areas: Any vending equipment placed with the intention of offering drive-up service, must provide one ADA accessible loading/unloading space, as well as an ADA access aisle, ADA routing path and ADA pavement markings along with one loading/unloading space for general use. Each loading/unloading space shall be nine (9) feet by twenty (20) feet.

8.5.5 Location

All ADA parking spaces must be located on the shortest accessible route of travel to an accessible facility entrance. Buildings which have multiple accessible entrances with adjacent parking must disperse and locate the spaces to the closest accessible entrances.

8.5.6 Signage and marking

- A. All ADA accessible spaces shall be designated by a sign with the international access symbol. Van accessible spaces shall include an additional sign indicating the space is "Van-Accessible" located below the sign providing the symbol of accessibility.
- B. All ADA signage, excluding the mobility impaired symbol painted on the parking space surface, shall be a minimum of five and one half (5 ½) feet above ground level so as not to be obscured by parked vehicles. The mobility impaired symbol shall also be painted on the ground to the rear of the parking space; the symbol shall be 3' square, centered in the space side to side and no more than 2 ½ feet from the rear of the space to the center of the symbol.

Table 8.1 - Parking Spaces Accessible to the Disabled

In substitution to the “Minimum Number of Accessible Spaces Required” below, uses with accessible visitor and patient parking at Hospital Outpatient Facilities must equal no less than ten percent (10%) of the required parking, and facilities which specialize in treatment or services for persons with mobility impairments shall provide accessible parking equaling no less than twenty percent (20%) of the required parking for visitor and patient use. Upon determination of the minimum number of accessible spaces required, Van Accessible spaces follow the table below.

For ADA parking space calculations, 2 motorcycle half spaces equals one standard parking space, the total of which is added to the parking space total. Each golf cart space counts as a full space toward establishing the ADA parking space requirements.

Total Number of Parking Spaces In Lot	Minimum Number of Accessible Spaces Required	Van Accessible Spaces Required
1 to 25	1	1
26 to 50	2	1
51 to 75	3	1
76 to 100	4	1
101 to 150	5	1
151 to 200	6	2
201 to 300	7	2
301 to 400	8	2
401 to 500	9	2
501 to 1000	2% of total	1 for every six required spaces or fraction of six
1001 and over	20 plus 1 for each 100 over 1000	1 for every six required spaces or fraction of six

8.6 PARKING DEVELOPMENT STANDARDS

With the exception of agricultural uses, automobile sales lots and where specifically exempted elsewhere in this Ordinance, all off-street parking areas shall be developed in accordance with the standards of this Section.

8.6.1 Dimensions

- A. Each required off-street parking space and, when required, its associated back-out aisle shall meet the dimensional standards as provided for in Table 8.2, exclusive of driveways, ramps or other amenities located within a parking area. All off-street parking spaces shall maintain a minimum of eight (8) feet of vertical clearance.
- B. With the exception of Single and Two-Family dwelling units, each off-street parking space shall open directly upon a back-out aisle at a minimum width prescribed by Table 8.2. Said opening is intended to provide safe and efficient means of vehicular access to such parking space. All back-out aisles and driveways shall be unobstructed and allow for the passage of emergency vehicles at all times.
- C. The manner for measuring the depth of a parking space shall be from the parking space front as if the space were laid out as a perpendicular space to the rear edge of the useable space measured at a ninety (90) degree angle, exclusive of any back-out aisle or driveway; see Figure 8.1 for clarification.

Figure 8.1 – Determining the length of an angle parking space

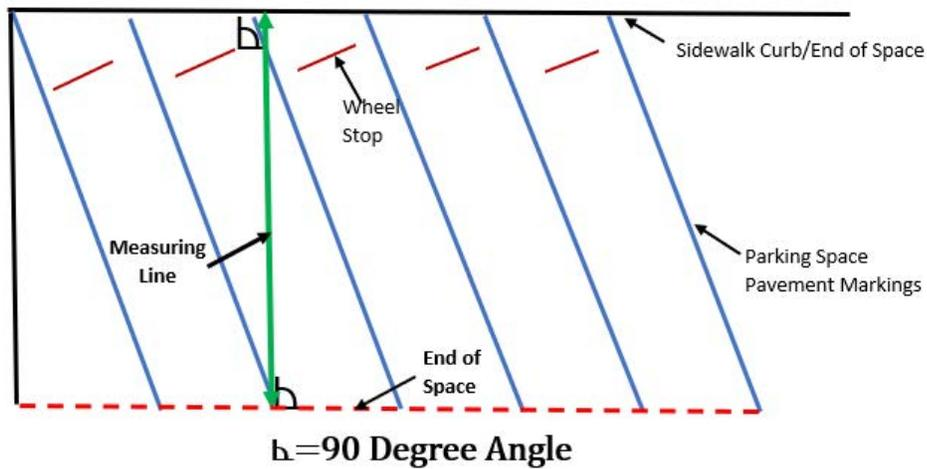

Table 8.2 - Minimum Space and Aisle Dimensions of Parking Spaces

Parking Angle¹ (in degrees)	Space Width (in feet)	Space Depth (in feet)	Back-out Aisle Width⁴ (in feet)
Parallel	9'²	22'	12'
Right Angle	9'	20'	24'
60° angle	9'	18'	18'
45° angle	9'	17'	18'
Small Car ⁽¹⁾	8'	15'	15'
Motorcycle ⁽²⁾	4 ½'	10'	8'
Golf Cart ⁽³⁾	7	10'	10'

¹ Spaces exclusive for compact or subcompact cars may be used only if specifically, designated "For Small Cars Only." A maximum of twenty-five percent (25%) of a parking area may be designated for small cars.

² Motorcycle spaces are voluntary and in addition to the minimum parking space requirements spelled out in this Chapter. The location and aisle width requirement(s) may be modified upon written authorization by the Executive Director

³ Golf cart spaces are voluntary and in addition to the minimum parking space requirements spelled out in this Chapter. The location and aisle width requirement(s) may be modified upon written authorization by the Executive Director.

⁴. Does not apply to single and two family residential units

8.6.2 Layout and design

- A. All off-street parking or loading facilities shall be designed with the appropriate means of vehicular access to a street or alley in a manner so as to lessen interference with traffic movement.
- B. The width of any driveway, as measured at the right-of-way line, shall not be exceeded for a distance of at least six (6) feet onto the subject property.
- C. No part of a parking space may encroach into a visual clearance triangle.
- D. Unless specifically authorized elsewhere in this Ordinance, a gravel area may not be used for vehicular parking.

8.6.2.1 Driveways, Parking Spaces and Back Out Aisles, Additional Standards:

A. Residential Driveways

1. No residential driveway which crosses a public street, private road or public alley right of way line shall exceed a width of thirty (30) feet at the right-of-way line; the driveway width at the right-of-way line must not be exceeded for a minimum of six (6) feet from the property line or right-of-way line whichever is most restrictive.
2. All properties utilized for residential purposes, excluding those in a B-1 or B-4 district, are allowed to have only one of the following driveway configurations:
 - a. A single driveway with a single ingress/egress point not to exceed thirty (30) feet in width at the right-of-way line;
 - b. A single driveway with two (2) driveway ingress/egress points (semi-circular drive), each access point shall be limited in width to twenty (20) feet at the right-of-way line with the closest point of the driveway openings having a minimum of ten (10) feet of separation at the right-of-way line; or,
 - c. Two (2) single point driveways as long as each driveway is under twenty (20) feet in width at the right-of-way line and the driveways maintain a minimum separation of ten (10) feet at all times.
3. All residential driveways within a municipality or the defined limits of Buffalo or Idaville must be constructed of a concrete, asphalt or gravel surface or a material equivalent in durability to concrete or asphalt; all residential driveways outside a municipality or the defined limits of Buffalo or Idaville may be constructed of any material including leaving as dirt.
4. No part of a driveway utilized in conjunction with a residential use shall be closer than two (2) feet from any adjoining side property line unless the property owner provides a waiver properly executed by the abutting property owner. The waiver must be properly executed in writing on a form provided by the Staff. This form must be recorded in the office of the White County Recorder with a copy of the recorded waiver submitted to the Staff. Note: Two properties which share a driveway are exempt from this setback requirement.
5. Within any municipality or within the limits of Idaville or Buffalo, any new/planned driveway which is to cross a sidewalk or curb within any street or road right-of-way or which is intended to enter into a street or road right-of-way must follow the guidelines below:
 - a. The property owner or developer is required to obtain written permission for the development portion within the right-of-way from the appropriate legislative body, or its delegated authority, prior to initiating the driveway improvement.

- b. The driveway design must provide for the lowering of the street curb to be level with the street surface;
- c. The driveway surface is to be level with the existing or anticipated sidewalk;
- d. The driveway must provide an asphalt or concrete surface street approach. This approach shall be a minimum of ten (10) feet in length measured from the property side of the sidewalk or right-of-way line, whichever is most restrictive.
- e. Any portion of the driveway which lies within the road right-of-way shall be constructed in a manner as directed by the local body with jurisdiction over the right-of-way.; and,
- f. All driveways must meet the construction standards of Section 8.6.3, Subsection A.

B. Residential Parking Space Design and Layout

1. Each parking space shall measure the size required by Table 8.2.
2. No part of an area dedicated as a parking space shall be closer to a front property line or right-of-way line than six (6) feet
3. Within a municipality or the limits of Idaville and Buffalo, parking spaces must be surfaced in gravel, concrete, pavement or material equivalent in strength and features to concrete or pavement; in all unincorporated areas of the County, a dirt surface is permissible.
4. Interior parking, either inside a garage or building or under a carport may be utilized to satisfy the site's off-street parking requirement.

C. Commercial, Industrial or Institutional Driveways

1. No part of a driveway utilized in conjunction with a Commercial, Industrial or Institutional use shall be closer than twenty-five (25) feet to any adjoining residential property line, or ten (10) feet to any adjoining nonresidential property line, unless, in the opinion of the Executive Director, the driveway is designed in such a manner as to mitigate interference with traffic movement and visual impairments.
2. Any property used for Commercial, Industrial or Institutional purposes is allowed to cross over a road rights-of-way line with one (1) driveway per each abutting road for access to an employee and/or customer parking lot or for human loading/unloading, whether or not the parking area or loading/unloading zone is located in one section or multiple sections. For purposes of this Chapter, a vehicular travel route utilized to access a property, which is continuous from one ingress/egress point to another, is considered a single driveway. A. Each driveway may have up to two (2) ingress/egress points as long as, at the rights-of-way line, the ingress/egress perimeters are at least ten (10) feet apart (such as would be found on a semi-circular

driveway) and the width of each access point is not greater than thirty (30) feet.

3. In addition, each facility will be allowed up to two (2) driveways to support areas dedicated to shipping and receiving, merchandise loading and unloading, outdoor storage areas or equivalent use areas to the operation.
4. Additional driveways, in a number determined by the Executive Director as necessary for efficient facility use and which he/she determines do not create a site safety condition or significantly negatively contribute to the movement of adjoining traffic, are allowed upon written authorization by said Director.
5. Commercial, Industrial or Institutional driveways may be up to forty (40) feet in width at the right-of-way line. Up to sixty (60) feet in driveway width may be granted by the Executive Director upon demonstration by the property owner or facility operator that the additional width is necessary to create safe routing of vehicles, semi-trucks and trailers and/or facility equipment.
6. Upon written approval of the Executive Director, driveway throats may be allowed up to eighty (80) feet at the right-of-way line if needed to accommodate INDOT or municipality approach requirements. The property owner or facility operator must demonstrate that the additional driveway width is a requirement of INDOT or the municipality and receive written approval of the Executive Director who is to assure such design and location will provide safer vehicle routing as well as be accommodating to safe pedestrian circulation.
7. Within any municipality or within the limits of Idaville or Buffalo, any new/planned driveway which is to cross a sidewalk or curb within any street or road right-of-way, the property owner or developer is required to obtain written permission for such development from the appropriate legislative body, or its delegated authority, prior to initiating the driveway improvement. All such improvements shall meet the following requirements.
 - a. The driveway design must provide for the lowering of the street curb to be level with the street surface
 - b. Structuring the driveway surface to be level with the existing sidewalk
 - c. Provide an asphalt or concrete surface for any portion of the driveway which abuts a sidewalk and then which extends to the Road/Street (not alleys) pavement within the Road/Street right-of-way; and
 - d. All driveways and back-out aisles must meet the construction standards of Section 8.6.3, Subsection A.

D. Commercial, Industrial or Institutional Off-street Parking Space Design & Layout

All required off-street parking spaces shall be designed, arranged and regulated so that:

1. Such concrete or paved parking areas are lined or designated to insure the most efficient use of the parking spaces.
2. Individual spaces shall be located so that no part of the parking lot perimeter, excluding driveways, or any part of a parked vehicle extends any closer than six (6) feet to any front, rear or side property line or right-of-way line, whichever is most restrictive. Parking spaces may not extend into any pedestrian circulation route.
3. Any space which has a front which is bordered by vegetated land, a sidewalk or is within five (5) feet of a building must be restricted by a wheel stop or a curb.
4. All parking spaces shall be unobstructed and have access to a back-out aisle or driveway so that any automobile may be moved without moving another, and so that no maneuvering directly incidental to entering or leaving a parking space shall be on any public right-of-way or walkway. All parking spaces must be positioned so that after backing out of the space, the driver can pull forward out of the parking lot by turning no more than ninety (90) degrees from their pull-out position. Positioning a parking space in a manner which would possibly subject the vehicle to having to reverse position by an angle greater than ninety (90) degrees to exit the parking lot shall be prohibited.
5. All parallel parking spaces shall be set back a minimum of five (5) feet from any wall of a building.
6. All wheel stops shall sit such that the closest side of the wheel stop to the building, sidewalk or vegetated area is no closer to the end of the space than twenty-four (24) inches or eighteen (18) inches for spaces dedicated to compact parking. In a case where curbing abuts a parking space, the sidewalk or vegetated area must be a minimum of five (5) feet in depth. Wheel stops that are used to separate two parking spaces shall have no setback requirement.
7. For commercial or industrial applications, no part of a parking may be closer to any building wall than five (5) feet except for parking spaces located within a building. This requirement may be waived or modified by the Executive Director, if, in his/her sole opinion, waiving or modifying this requirement will not negatively impact pedestrian circulation nor create some other type of potential unsafe condition.
 - a. Off-street parking spaces may be open to the sky or enclosed in a building. In any instance, when a building is constructed on

- a vacant lot, said building shall be treated as a principal structure and shall be subject to all requirements thereof.
- b. Parking areas may accommodate one (1) single story shelter or guard shack which shall not exceed one hundred (100) square feet of gross floor area and shall conform to all the structural requirements of the District in which it is located. The shelter/guard shake may be located no closer than 6' from front property line or right-of-way line, whichever is most restrictive, and may not encroach into visual clearance area.
 - c. When determined necessary by the Executive Director, a parking area shall provide a means of pedestrian circulation to its associated use as well as between the associated use and the street. All pedestrian circulation routes designed within the parking lot area must be so designated with appropriate markings on the pavement. Each parking space area must be accessed by a sidewalk or cross hatched pavement area. Each sidewalk or cross hatched pavement area must be a minimum of three (3) feet wide.
 - d. Any lighting used to illuminate any off-street parking area shall be so located, shielded and directed upon the parking area in such a manner that it does not reflect or cause glare onto adjacent properties or interfere with street traffic. In no instance shall bare, unshaded bulbs be used for such illumination

8.6.3 Surfacing and drainage

- A. With the exception of parking dedicated for ballfields/parks, campgrounds and amusement parks, Laydown Yards, or, unless specifically exempted elsewhere in this Chapter, all open, off-street parking areas, including but not limited to parking spaces, drives and back-out aisles, shall be surfaced with an all-weather, dust-free concrete or asphalt material. Minimum construction of all parking spaces, drives and back-out aisles developed in conjunction with commercial, industrial or institutional uses shall consist of no less than eight (8) inches of an aggregate material and four (4) inches of surface material or certified to a standard which, in the sole discretion of the Executive Director, is determined to be equal or better than the construction standard required. Upon written approval from the Executive Director, an aggregate surface may be used for a period not exceeding one (1) year after the date of granting the Certificate of Occupancy. This exception does not apply to any portion of the parking area required to satisfy ADA requirements. All open, off-street parking areas shall be maintained in good condition and free of weeds, dirt, trash and debris
- B. All aggregate parking lots must comply with ADA requirements of this Ordinance unless specifically exempted by Federal Law

- C. All open, off-street parking areas shall be graded and properly drained in such a manner that there will be no free flow of water onto either adjacent property or public sidewalks. Further, any additional run-off generated by such improved areas shall be disposed of in appropriate drainage facilities
- D. In any paved parking area that does not have wheel stops; the surface shall be painted, marked, or otherwise delineated so that each parking space is readily apparent.

8.7 PARKING AND STORAGE OF CERTAIN VEHICLES

8.7.1 Nuisance vehicles

With the exception of those located within a completely enclosed structure, automotive vehicles or trailers of any type which are without current registration or any inoperable automotive vehicle shall be prohibited in all residential zoning districts. Unless specifically authorized under the terms of this Ordinance, no automotive vehicle or trailer of any type which is without current registration, or any inoperable automotive vehicle or trailer not enclosed in a structure shall be parked or stored in any non-residential district.

8.7.2 Commercial vehicles

The parking of commercial, self-propelled vehicles, excluding semi-trucks or tractor trailers, shall be prohibited in all residential zoning districts unless the vehicle is used by the occupant of the premises. No more than one (1) semi-truck or tractor trailer, at a time, is allowed to be parked or stored on any residential lot. This requirement shall not be interpreted to prohibit commercial vehicles from temporary loading and unloading in any residential district.

8.7.3 Temporary/Portable Storage Units

Temporary/portable storage units shall be permitted in any residential district, provided that they comply with the following minimum standards:

A. Time Limitation

No temporary/portable storage unit may be located on any site, in any residential district for a period longer than ten (10) consecutive days from time of delivery to time of removal. At the end of such period, the temporary storage unit shall be moved off-site and shall not be returned for at least one (1) month from the date it was removed. This does not apply to a dumpster used in conjunction with a construction, reconstruction, remodel or refurbishment project. Dumpsters may remain for the duration of the construction activity but must be removed within seven (7) days from the day the construction activities cease.

B. Number of Units

No more than two (2) temporary/portable storage units may be located on a lot of record at one time.

C. Location

No temporary/portable storage unit may be located closer than ten (10) feet to any property line. Under no circumstances may a temporary/portable storage unit be located within a public right-of-way.

D. Removal

In the event of high winds or other adverse weather conditions in which such a structure may become a physical danger, the Executive Director or any law enforcement officer may require the immediate removal of such temporary structure. In the event that a unit has been in place longer than the time period specified in (a) above, the Executive Director shall cause said structure to be removed. In any instance, all costs associated with the removal of a temporary/portable storage unit shall be the responsibility of the landowner

E. Use

No temporary/portable storage unit shall be used to store solid waste, construction debris, demolition debris, recyclable materials, business inventory, commercial goods, or any illegal or hazardous material.

8.8 DESIGN FLEXIBILITY

8.8.1 Reduction of parking

Due to particularities of any given development, the application of the minimum parking requirements prescribed by this Chapter may result in parking spaces and loading areas which exceed the need of the associated uses. Upon written request of the applicant, the Executive Director may authorize a reduction in the minimum parking requirements, provided that the reduction is no more than fifty (50) percent of the minimum parking requirements for said use. Approval of a reduction in the number of required parking spaces by the Executive Director shall be in writing and shall include justification for allowing such reduction.

8.8.2 Phasing of minimum parking requirements

Upon written request by the applicant, up to twenty-five (25) percent of a dedicated parking area may remain unpaved greenspace until such time as the remainder of the parking area is needed. This decision and determination shall be at the discretion of the Executive Director. Such greenspace shall not be counted toward required parking landscaping or buffer yard as specified in Chapter 9, Landscaping Standards.

8.8.3 Deviation from minimum parking requirements

Applicants submitting development plans for the B-1 Neighborhood Business District, may submit an alternative plan not meeting the requirements of this Chapter if space limitations prevent compliance with this Chapter. Such plans are subject to approval, denial or revision as determined by the Executive Director.

8.9 DRIVE-THROUGH AND SERVICE POINT STACKING SPACE REQUIREMENTS

All establishments with a drive-through window or customer service point such as a fuel pump or pick-up door, shall provide a minimum number of stacking spaces for the queuing of vehicles awaiting use of such facilities. All required stacking spaces shall be in addition to the required parking spaces for the facility and in addition to the parking space for the vehicle using the drive-through window or service point. No required stacking space shall be located within a required driveway, internal circulation system, or parking aisle.

8.9.1 Stacking lane dimensions and markings

Each stacking space shall be a minimum of eighteen (18) feet long, and each lane of stacking spaces shall be a minimum of nine (9) feet wide. Lane widths should be delineated with pavement markings. Individual stacking spaces within the lane need not be marked.

8.9.2 Number of stacking spaces

Table 8.3, Minimum Required Vehicle Stacking Spaces denotes the number of stacking spaces required for common drive-through or service point uses.

Table 8.3 Minimum Required Vehicle Stacking Spaces

Activity Type	Minimum Stacking Spaces	Measured From
ATM	1	Per Machine
Bank teller lane	4	Teller or Window
Restaurant, drive-through	6	Staging for Order box
Restaurant, drive-through	4	Order box to pick-up window
Car wash, automatic	6	Each stall entrance
Car wash, full service	6	Each service entrance
Car wash, self service	3	Each stall entrance
Gasoline pump island	2	Each service side of a pump or pump island
Truck stop island	2	Each service side of a pump or pump island regardless of the number of pumps
Truck wash	2	Each wash station entrance
Other uses not specified	As prescribed by the Executive Director, but never less than two (2).	

8.10 LOADING SPACE REQUIREMENTS

Uses and buildings with a gross floor area of five thousand (5,000) square feet or more which receive or transmit goods or wares by truck delivery shall provide off-street loading spaces in accordance with Table 8.4, Loading Space Requirements. Spaces which accommodate off-street loading shall not be used to satisfy any required off-street parking requirements. External or internal loading docks may be counted to satisfy the requirements of this Section.

Table 8.4 – Loading Space Requirements

Use Description	Floor Area in Square Feet	Number of Loading Spaces Required
Manufacturing, distribution, wholesaling, industrial warehouse, commercial storage, and similar uses	5,000 - 25,000	1
	25,001 - 60,000	2
	60,001 – 100,000	3
	Each 50,000 above 100,000	1
Office Buildings, hotels and motels, retail sales, hospitals, institutions, and similar uses	5,000 – 60,000	1
	60,001 – 100,000	2
	Each 10,000 above 100,000	1
Recycling Satellite, Private		As determined by the Executive Director
Recycling Satellite, Public		2 per recycling container or recycling trailer (1/side)
Other uses not specified	As prescribed by the Executive Director	

Boat Storage facilities must provide a rectangular loading and unloading space which extends the entire length of the facility and perpendicular to the building a minimum of fifty (50) feet. This is in addition to satisfying any ADA requirements established by this Ordinance or by Federal or State law, code or regulation.

8.10.1 Location

All required off-street loading berths shall be located on the same lot as the use they are intended to serve. No portion of any off-street loading area shall cause any vehicle to project into an adjacent street or alley right-of-way. No permitted or required loading berth shall be located within twenty-five (25) feet of the nearest point of intersection of any two (2) streets, nor shall it be located in a required front yard or side yard adjoining a residential use or district.

8.10.2 Size

Each required off-street loading space shall be accessible when the off-street parking spaces are at their capacity. In addition, all off-street loading spaces shall be in conformance with the following:

- A. For local pick-up and delivery trucks: twelve (12) feet in width by thirty (30) feet in length with a forty-five (45) foot maneuvering apron, and a twelve (12) foot height clearance. The maneuvering apron must be comparable to the detailed requirements noted in "B." below.
- B. For over-the-road tractor-trailers: fourteen (14) feet in width by sixty (60) feet in length with a sixty (60) foot maneuvering apron, and a fifteen (15) foot height clearance. The maneuvering apron shall be a minimum of 60' long and 14' wide and will be an extension of the loading space requirement. This results in an area dedicated to the loading space and maneuvering apron of no smaller than 14' wide x 120' long. The 120' of length is required to be entirely on the property, none may be delineated in a right of way. The maneuvering area may coincide with a driveway or parking lot aisle as that area would not be used by the truck for anything else but maneuvering so any parking space blockage would be very short lived.
- C. An alternative to this design requirement may be submitted and if the alternative design provides safer or more efficient use of land without purposes of the parking lot impaired, restricted or altered and better accomplishes the ability of a truck to properly position itself for loading/unloading, the Executive Director may provide approval to the alternative design. Such approval must be in writing and in advance of issuing an improvement location permit for the subject development.
- D. At no time can the loading space occupy a dedicated parking space nor may it be laid out in a manner which could block or prevent ingress/egress to a vehicle parking space or other amenity of the parking lot
- E. For loading/unloading of any Class 1 vehicle, nine (9) feet in width by twenty-two (22) feet in length.

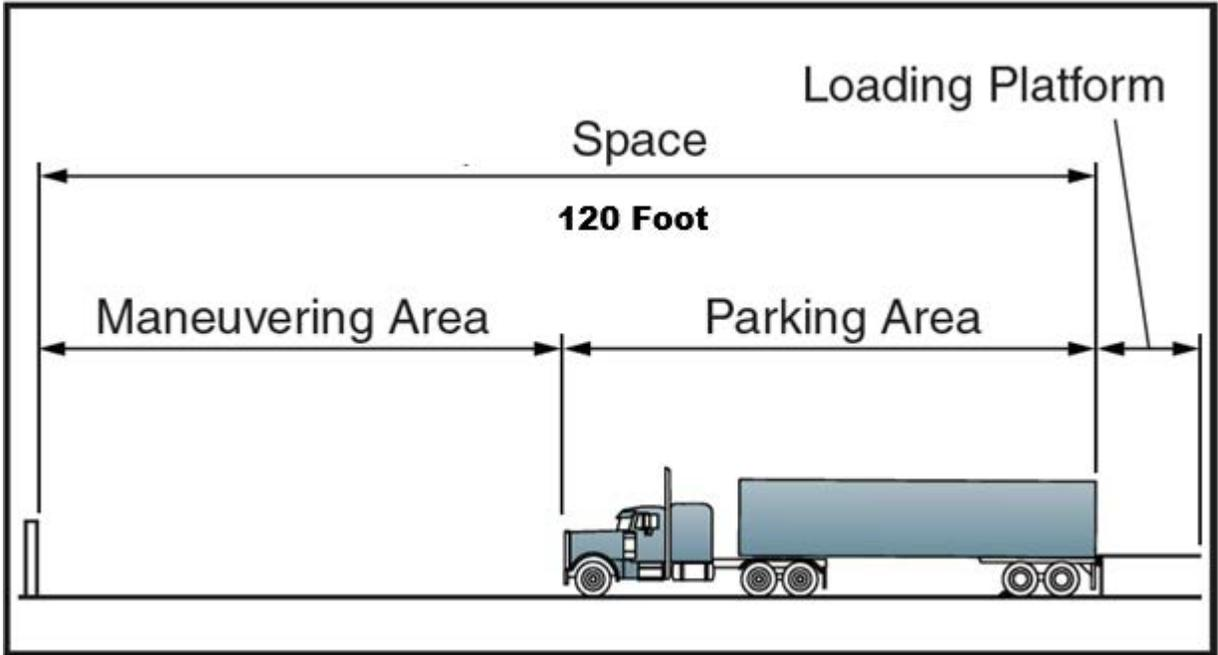

8.10.3 Surface

Unless otherwise permitted by this Ordinance, all open off-street loading spaces shall be improved with an aggregate base with a minimum thickness of six (6) inches and surfaced with not less than two (2) inches of asphaltic concrete or some comparable all-weather dustless material. In addition, paving and drainage regulations for loading areas shall be in accordance with the paving and drainage regulations for parking areas as set forth in this, or any other applicable Ordinance.

8.10.4 MINIMUM SETBACK DISTANCES FOR CERTAIN PARKING AND LOADING SPACES

A parking area or loading space for any of the following uses shall be setback from all residential zoning districts as prescribed by Table 8.5, Minimum Setback Distances for Certain Parking/Loading Areas, following.

Table 8.5 - Minimum Setback Distances for Certain Parking/Loading Areas

Use	Parking Area	Loading Area
Airport	25 feet	100 feet
Commercial facilities for raising or breeding non-farm fowl & animals	25 feet	100 feet
Commercial greenhouse	N/A	50 feet
Junk yard	1,320 feet	1,320
Outdoor commercial recreation uses	25 feet	50 feet
Penal or correctional institution	300 feet	300 feet
Private recreational development	25 feet	50 feet
Sales barn for livestock sale	50 feet	100 feet
Truck terminal	100 feet	100 feet
Wholesale produce terminal	100 feet	100 feet

8.11 ADDITIONAL REQUIREMENTS FOR OFF-STREET PARKING AND LOADING PLANS

Off-street parking facilities shall be developed in accordance with the provisions of this Section.

8.11.1 Off-street parking and loading plan

An off-street parking and loading plan shall be filed as part of any required site development plan, and shall be made part of the conditions of any approval thereof. Said off-street parking and loading plan shall demonstrate compliance with Chapter 12, Administration, of this Ordinance. Said off-street parking and loading plan shall indicate:

- A. All individual primary uses to be served, including the location of the use and number of parking spaces for each such use;
- B. lanes, parking spaces, setbacks, drainage facilities;
- C. Landscaping and buffer screening;
- D. Type of lighting and paving proposed, and,
- E. Identification of signs, including their location, size and design thereof.

- F. At the sole discretion of the Executive Director, a business location where on-street parking or public parking lots are available, the Executive Director may provide a parking space allowance in a quantity he/she determines is appropriate against that business' off-street parking space.

8.11.2 Lease or easement

Off-street parking facilities encumbered by any instrument (lease or easement) duly executed and acknowledged, which subject said accessory off-street parking facilities to parking uses in connection with the primary use served. Said instrument shall specify and bind the time period to the anticipated life of the building or use to which the parking facilities are accessory. Said instrument shall be filed in the applicable Permit files of the Office of the Executive Director, and placed on public record in the office of the White County Recorder.

8.11.3 Setbacks

Off-street parking structures, commonly referred to as a parking garage, shall be provided with setback distances equivalent to the requirements of the district for principal structures unless otherwise provided for in this Ordinance. Points of ingress and egress shall be limited to protect the function of adjoining streets.

8.11.4 Minimum number of spaces required

The minimum number of required off-street parking spaces shall be provided according to Table 8.6, Required Off-Street Parking Spaces unless otherwise specified in this Ordinance.

8.11.5 Calculating the minimum number of spaces required

In determining the minimum required number of off-street parking spaces, the following instructions shall be applicable to such computations:

- A. Any fraction of less than one-half (1/2) shall be disregarded, while a fraction one-half (1/2) or greater shall be counted as one parking space.
- B. For uses not specified in this Section or when the adequate number of spaces is unclear, the minimum number of spaces shall be determined by the Executive Director. The Executive Director shall base the minimum number of parking spaces required on the basis of similar requirements, the number of persons served or employed, and the capability of adequately serving the visiting public. Such determination may be reviewed by the Area Plan Commission or appealed to the Board of Zoning Appeals.
- C. In sports arenas, churches and other places of assembly in which patrons occupy benches, pews, or other similar seating, each twenty-two (22) inches of such seating shall be counted as one (1) seat for the purpose of determining requirements, unless otherwise stated.
- D. In the case of open floor areas used for temporary seating purposes, an area of sixteen (16) square feet usable for seating shall be counted as one (1) seat for the purposes of administering and enforcing this Chapter.

- E. For the purposes of determining off-street parking requirements under this Chapter, gross floor area shall mean the total horizontal area of each floor of all buildings excluding guard shacks and accessory buildings of three hundred square feet or less. Public floor space/area is gross floor area less areas devoted entirely and permanently to storage purposes, parking and loading facilities, or space used for restrooms, utilities, machinery rooms, stairs or elevator shafts/lifts. In the case of a restaurant, bar areas are included while the area dedicated to kitchen facilities shall be excluded.
- F. For the purposes of calculating parking requirements, each category of use on a lot shall be considered separately, unless otherwise provided for by this Chapter.
- G. Unless otherwise provided for by this Chapter, the number of required off-street parking spaces shall be considered the minimum number of spaces required for any particular use.
- H. Every company car, truck, tractor-trailer normally stored at a business site shall be provided with an off-street parking space. Such space shall be in addition to the minimum parking requirements listed in Table 8.6, Required Off-Street Parking Spaces.
- I. Event Barn, Excess Parking: Excess parking is an open area where peak parking is allowed and has either a gravel or grass surface. To calculate the number of parking spaces credited for an excess parking area, a site plan should delineate the parking configuration of the area as if the lot were to be paved utilizing the space and aisle sizes provided for in this chapter.

8.11.6 Administrative Adjustment

Any applicant may request an adjustment from the minimum parking standards. The request must be in writing and include a justification for the adjustment. If, in the sole discretion of the Executive Director, the justification allowance is quantifiable, credible and does not exceed 50% of the minimum requirement, the Executive Director may adjust the minimum parking requirements for the applicant's site to the level the Executive Director determines is warranted, which may or may not be less than the applicant requested. Any decision of the Executive Director on this matter may be appealed to the Area Board of Zoning Appeals.

8.12 ELECTRIC VEHICLE CHARGING STATIONS

All parking areas may include spaces for public or private electric vehicle charging stations. The spaces for electric vehicle charging stations may be included in the total parking space count requirement of a site. ADA accessible electric vehicle charging stations shall not count toward any ADA parking requirements applicable to the site.

8.12.1 General Requirements

- A) Setbacks: All Electric Vehicle Charging Stations (EVCS), public and private, including charging station equipment and support structures are subject to parking lot developmental standards with a height restriction of nineteen (19) feet. EVCS parking spaces and any EVCS Accessible parking space or associated component is subject to the standards, regulations and requirements of this Chapter.
- B) Private EVCS:
 - 1. Private EVCS locations are exempt from the Improvement Location Permit requirement.
 - 2. All private, EVCS locations are permitted in every zoning district when accessory to the primary, permitted use.
- C) Public EVCS:
 - 1. Each site which offers one or more Public EVCS's, must obtain an Improvement Location Permit prior to installation. Each EVCS Improvement Location Permit can cover multiple EVCS's when the EVCS installations are to be located on the same parcel and requested simultaneously under the same permit.
 - 2. Each public EVCS must be located at the head or side of a parking space. The parking space must meet the standards for parking spaces found in Chapter 8 of the White County Indiana Zoning Control Ordinance and, in addition, utilize a wheel stop, bollards, curb, concrete island or other appropriate barrier to prevent vehicular damage to the EVCS equipment and its infra-structure.
 - 3. Each public EVCS parking space must have an EVCS designated pavement marking, a minimum of two (2) foot square in size and no further than two (2) feet from the end of the space and centered accordingly. Said marking shall be painted utilizing a green background and white symbols such as that shown below. Alternative images are acceptable under the required color scheme as long as they effectively convey the message for the purpose of the parking space.



4. All public, EVCS locations, where vehicle electrical charging is one of the principal services provided at the site, shall be categorized for use as either a gasoline service station, neighborhood convenience store or regional convenience store based on the services and amenities offered and shall follow such zoning regulations as are applicable to the use assignment.
5. Each public EVCS site must comply with the following accessibility requirements:
 - (a) Provide a minimum of one (1) Van accessible EVCS space;
 - (b) Provide one (1) additional Van accessible EVCS space for each ten (10) EVCS spaces beginning with space eleven (11);
 - (c) Each accessible EVCS space must comply with all ADA standards applicable to ADA parking spaces, access aisles and routing; and,
 - (d) Each accessible EVCS space shall incorporate accessible access to EVCS equipment and connection devices.

Table 8.6 - Required Off-Street Parking Spaces*

***These are in addition to stacking and/or loading requirements defined elsewhere in this chapter.**

Use Category	Minimum Parking Requirements
Adult entertainment business	1 space per 200 square feet of building gross floor area
Agri bio production	1 space for every 400 square feet of building gross floor area.
Agricultural industry	1 space for every 400 square feet of building gross floor area.
Agricultural produce business, permanent	1 space for every 200 square feet of building gross floor area.
Agricultural produce business, seasonal	None
Agricultural produce sales, portable	None
Agricultural research firm	1 space for every 400 square feet of building gross floor area.
Agricultural roadside stand	None
Agriculture	None
Agriculture service & support	1 space for every 400 square feet of building gross floor area.
Airport	1 space per 2 employees plus 1 space per passenger based on daily transient aircraft
Amphitheater	At the Executive Director's sole discretion, to be determined by the requirements as provided in subsection 8.11.5 C or D;
Amusement park (This is used for the purposes of establishing ADA parking requirements for the operations).	1 space per three thousand (3,000) square feet of outdoor active recreation space, plus any additional spaces required for ancillary uses such as, but not limited, to game centers, theaters, restaurants, rides, amusements and billiard halls.
Amusement park offices (Located in a non-AED District); otherwise, refer to "Business Office" requirements	1 space for every 400 square feet of building gross floor area.

White County Zoning Ordinance Parking and Loading Standards

Use Category	Minimum Parking Requirements
Animal sanctuary	1 space for every 400 square feet of building gross floor area.
Animal shelter	3 spaces per 1,000 sq.ft. of gross floor area
Antennae, amateur radio; radio; television	None
Antennae, radio	None
Antennae, television	None
Apartment	2 spaces per apartment
Apartment, accessory	1 space in addition to primary dwelling requirements
Apartment, micro-unit	1 space per unit
Arcade	See Recreational Facility, Indoor
Asphalt plant (manufacturing)	1 space for every 400 square feet of building gross floor area; plus, 1 space for each vehicle company vehicle
Auction sale	None
Assisted living facility	1 space per 3 sleeping rooms; plus 1 space per employee on the largest shift
Auction arena or sales barn (for livestock)	Requirements as provided in Section 8.11.5
Auction arena or sales yard (excluding livestock)	1 space per 150 sq.ft. building gross floor area space; plus 1 space per 50 sq.ft. seating/standing area
Automated teller machine	None; but, must provide stacking space as required by Section 8.9
Automobile convenience mart	1 space for every 150 square feet of building gross floor area.
Automobile parts/supply retail establishment	1 space for every 150 square feet of building gross floor area.
Automobile rental/leasing establishment	1 space for every 400 square feet of building gross floor area.
Automobile sales	1 spaces per 600 sq.ft. of building gross floor area; plus 2 spaces per service bay.

White County Zoning Ordinance Parking and Loading Standards

Use Category	Minimum Parking Requirements
Automotive service; major	1 space per 400 square feet of building gross floor area; plus, 2 spaces per service bay
Automotive service; minor	1 space per 400 square feet of building gross floor area; plus, 2 spaces per service bay.
Bail sales	See retail establishment (0 to 99,999 gsf)
Bake sale	None
Bakery or delicatessen	See retail establishment (0 to 99,999 gsf)
Ballroom	1 space per 600 square feet of building gross floor area
Bank	1 space per 400 square feet of building gross floor area
Banquet Hall	1 space per 600 square feet of building gross floor area
Bathhouse	None
Batting Cages, Commercial	1; plus, 1 space per cage
Bazaar	None
Bed and breakfast	1 space per guest room; plus, 1 space per employee; plus, 2 spaces for owners.
Bio-medicine facility	1 space per 400 square feet of building gross floor area
Bio-processing plant	1 space per 400 square feet of building gross floor area
Boarding house/rooming house	2 spaces; plus 1 space per sleeping room
Boat sales & service	See Automobile Sales
Boat storage, commercial	Loading/Unloading paved, maneuvering area extending fifty (50) feet from all entrance/exit points along the entire entrance/exit wall of the building.
Body piercing (See personal/professional services)	
Botanical garden/botanic garden/botanical institution	1 space per 150 sq.ft. of indoor exhibit area
Bottled gas storage and distribution yard	1 space per 400 square feet of building gross floor area

White County Zoning Ordinance Parking and Loading Standards

Use Category	Minimum Parking Requirements
Bowling Alley	5 spaces per lane
Brew pub	One (1) parking space for each fifty; (50) square feet of building gross floor area; plus, one (1) space for each two hundred (200) square feet of outdoor dining and entertainment area
Brewery	One (1) parking space for each fifty; (50) square feet of building gross floor area; plus, one (1) space for each two hundred (200) square feet of outdoor dining and entertainment area.
Brewery, craft	One (1) parking space for each fifty; (50) square feet of building gross floor area; plus, one (1) space for each two hundred (200) square feet of outdoor dining and entertainment area.
Brewery, micro	One (1) parking space for each fifty; (50) square feet of building gross floor area; plus, one (1) space for each two hundred (200) square feet of outdoor dining and entertainment area.
Bunkhouse	None
Bus garage	1 space per 400 square feet of building gross floor area
Bus lot	1 space per 400 square feet of building gross floor area
Bus station (passenger)	1 space per 200 square feet of building gross floor area.
Business Office	1 space per 400 square feet of building gross floor area
Cabana	None
Cabin	2 spaces (per residential standards)
Campground	1 space per camp site plus 2 spaces per cabin (per residential standards)
Carwash	1 space per 400 square feet of building gross floor area
Caretaker home	1 space (per residential standards)
Carnival	None

White County Zoning Ordinance Parking and Loading Standards

Use Category	Minimum Parking Requirements
Carport	None
Casino	Refer to Chapter 8, 'Calculating the minimum number of spaces required' for details
Catering service	1 space per 400 square feet of building gross floor area
Cemetery	1 space per 400 square feet of building gross floor area
Child care center	1 space per employee on the largest shift; plus, 1 space per 5 children (per residential standards).
Child care home *(1)	1 space per employee on the largest shift; plus, 1 space per 5 children (per residential standards); this is in addition to the spaces required for dwellings if the site is also used as a residence.
Child care house	2 spaces (per residential standards); these spaces may be shared spaces with those satisfying the residential requirements of the site
Children's play equipment	None
Christmas tree sales	None
Circus	None
Club or lodge, private	One (1) parking space for each fifty; (50) square feet of building gross floor area; plus, one (1) space for each two hundred (200) square feet of outdoor dining and entertainment area. 1 space per 4 persons at maximum capacity
Commissary	1 space per 400 square feet of building gross floor area
Community center	1 space per 250 sq. ft. of building gross floor area
Community commons (pocket park)	None
Concessions	None
Concrete or cement batching plant, permanent	1 space for every 400 square feet of building gross floor area; plus, 1 space for each vehicle company vehicle

White County Zoning Ordinance Parking and Loading Standards

Use Category	Minimum Parking Requirements
Concrete or cement batching plant, portable	None
Condominium (per IC 36-1-6 as amended)	Refer to the requirements for Multi-family dwellings
Conference center/meeting hall	1 space per 250 sq. ft. of building gross floor area
Conference facility	1 space per 250 sq. ft. of building gross floor area
Confined feeding operation	None
Construction yard/lay down yard	1 per 300 square feet of building gross floor area; plus, 1 space per vehicle used in conjunction with the business None
Construction, heavy contractors	1 space per 400 square feet of building gross floor area
Convenience store, neighborhood	1 spaces per 400 sq.ft. of building gross floor area
Convenience store, regional	1 space per 300 sq.ft. of building gross floor area
Convention center/exhibition hall	1 space per 250 sq. ft. of building gross floor area
Correctional/penal facility/prison/jail	1 space per 400 square feet of building gross floor area
Cottage/summer home	2 spaces
Crematory	1 space per 800 square feet of building gross floor area
Day care center, adult	1 space per 400 square feet of building gross floor area
Digester, aerobic or anaerobic	1 loading space per digester
Distillery	One (1) parking space for each fifty; (50) square feet of building gross floor area; plus, one (1) space for each two hundred (200) square feet of outdoor dining and entertainment area.
Distillery, micro or boutique	One (1) parking space for each fifty; (50) square feet of building gross floor area; plus, one (1) space for each two hundred (200) square feet of outdoor dining and entertainment area.
Distribution center	1 space per 400 square feet of building gross floor area

White County Zoning Ordinance Parking and Loading Standards

Use Category	Minimum Parking Requirements
Driving range	1 space per 3 tee sites; plus 1 space per 400 square feet of building gross floor area
Dwelling, attached single-family	2 spaces per dwelling unit (per residential standards)
Dwelling, farm	2 spaces (per residential standards)
Dwelling, multi-family	1.75 per dwelling unit (per residential standards)
Dwelling, single-family	2 spaces per dwelling unit (per residential standards)
Dwelling, student/fraternity/sorority	1 space per 250 square feet of building gross floor area
Dwelling, two-family	2 spaces per dwelling unit (per residential standards)
Educational facility, college, university, public or private	1 space per classroom and 1 space per 400 square feet of building gross floor area
Educational facility, elementary, secondary (up to grade 12), public or private	(K-8) 1 space per classroom plus, one space per 400 square feet of gross floor area ; (9-12) 1 space per classroom; plus, one space per 100 square feet of institutional floor area
Educational facility, other, public or private	1 space per classroom; plus, one space per 400 square feet of building gross floor area
Entertainment facility, commercial;	1 space per 150 feet of building gross floor area
Engine Repair, Large	See Automobile Service, Major
Engine Repair, Small	See Automobile Service, Minor
Equipment sales and leasing	See Retail or Wholesale for requirements
Event Barn	1 space per 200 square feet of gross floor area. In unincorporated areas of the County, a minimum of 25% of the parking requirement must be paved in compliance with this Chapter, the balance may be developed under the Excess Parking Standard section of this Chapter. All ADA accessibility provisions must meet all ADA requirements.
Event government	None
Event, special	None

White County Zoning Ordinance Parking and Loading Standards

Use Category	Minimum Parking Requirements
Event, sporting	None
Ethanol plant	1 space per 400 square feet of building gross floor area
Explosives, use or storage	1 space per 400 square feet of building gross floor area
Fairgrounds	1 space per 400 square feet of building gross floor area
Farm chemical/fertilizer supplier	See Retail or Wholesale for requirements
Farming, micro	None
Festival	None
Fire, police (w/o jail facilities), postal stations	1 space per 400 square feet of building gross floor area
Fireworks sales	See Retail or Wholesale for requirements
Flea market	See Retail or Wholesale for requirements
Funeral home or mortuary	1 space per 400 square feet of building gross floor area
Garage, attached	1 space (per residential standards)
Garage, detached	1 space (per residential standards)
Gasoline service station	1 space per 400 square feet of building gross floor area; plus, 2 spaces per service bay
Go-kart facility	1 space per 400 square feet of building gross floor area; plus, 1 space per 400 square feet of outdoor recreational area
Golf course	4 spaces per golf holes; plus, 1 space per 400 square feet of building gross floor area
Government building	1 space per 1,000 square feet of building gross floor area other than office area; plus, 1 space for each vehicle used in conjunction with the facility's use plus 1 space per 200 square feet of general office area.
Grain elevator	1 space per 200 square feet of building gross floor area
Grandstand	1 space per 4 seats at maximum capacity

White County Zoning Ordinance Parking and Loading Standards

Use Category	Minimum Parking Requirements
Greenhouse, commercial	1 space per 400 square feet of building gross floor area
Greenhouse, non-commercial	None
Grocery store or supermarket	See Retail or Wholesale for requirements
Group home	2 spaces; plus, one space per 3 sleeping rooms
Guard shacks	1 space; plus, 1 space for every 200 square feet of building gross floor area over 100 square feet
Guest house	2 spaces (per residential standards)
Gun sales	See Retail or Wholesale for requirements
Gun smith	1 space per 500 sq.ft. of building gross floor area
Hatchery, commercial	1 space per 400 square feet of building gross floor area
Hazardous waste landfill/facility	1 space per 400 square feet of building gross floor area
Health and fitness center	1 space per 200 square feet of building gross floor area 5 spaces per 1,000 sq.ft. of gross floor area
Health center, public	1 space per 150 square feet of building gross floor area
Heliport	2 spaces per aircraft landing station
Home occupation	See respective dwelling unit requirement
Hospital	1 space per 300 square feet of building gross floor area plus 1 space per hospital vehicle
Hotel	1 space per sleeping room; plus, 1 space for every 750 square feet of main floor gross floor area
Incinerator	1 space per 400 square feet of building gross floor area
Industrial park	Refer to Chapter 8, "Calculating the minimum number of spaces required" for details

White County Zoning Ordinance Parking and Loading Standards

Use Category	Minimum Parking Requirements
Industrial waste facility	1 space per 400 square feet of building gross floor area
Information center, visitor/tourist	1 space per 400 square feet of building gross floor area
Integrated Center	1 space per 150 square feet of building gross floor area
Internet selling establishment/e-bay store	1 space; plus, 1 space per 600 sq.ft. of building gross floor area
Jail	1 space per 400 square feet of building gross floor area
Junkyard	1 space per 400 square feet of building gross floor area
Kennel, commercial	1 space per 400 square feet of building gross floor area
Kennel, private	1 space per 400 square feet of building gross floor area
Laboratory, commercial	3 spaces per 1,000 sq.ft. of building gross floor area up to 20,000 sq.ft.; plus, 2 spaces per 1,000 sq.ft. of building gross floor area greater than 20,000 sq.ft.
Laboratory, medical or dental	3 spaces per 1,000 sq.ft. of building gross floor area up to 20,000 sq.ft.; plus, 2 spaces per 1,000 sq.ft. of building gross floor area greater than 20,000 sq.ft.
Laboratory, research activity & testing	3 spaces per 1,000 sq.ft. of building gross floor area up to 20,000 sq.ft.; plus, 2 spaces per 1,000 sq.ft. of building gross floor area greater than 20,000 sq.ft.
Land use amenity	None
Landfill	1 space per 150 square feet of building gross floor area
Landfill, sanitary	1 space per 150 square feet of building gross floor area
Landscape contractor	1 space per 400 square feet of building gross floor area; plus, 1 space for each vehicle used in conjunction with the business
Laundry facility, self-service	1 space per 300 sq. ft. of building gross floor area
Laundry or dry cleaning facility	1 space per 300 sq. ft. of building gross floor area

White County Zoning Ordinance Parking and Loading Standards

Use Category	Minimum Parking Requirements
Laydown Yard	See "Construction Yard"
Library	1 space per 400 square feet of building gross floor area
Manufactured home	2 spaces (per residential standards)
Manufactured home office, permanent	1 per 400 square feet of building gross floor area
Manufactured home park or subdivision	2 spaces per mobile home or trailer stand
Manufactured home park or subdivision, existing	2 spaces per mobile home or trailer stand
Manufactured home park or subdivision, expansion	2 spaces per mobile home or trailer stand
Manufactured home/modular home sales	1 space per 400 square feet of building gross floor area
Manufactured/Mobile Home; RV Dwelling	See Dwelling, Single Family
Manufacturing, extractive, non-urban	1 per 300 square feet of building gross floor area; plus, 1 space per vehicle used in conjunction with the business
Manufacturing, extractive, urban	1 per 200 square feet of building gross floor area; plus, 1 space per vehicle used in conjunction with the business
Manufacturing, heavy	1 space per 350 square feet of office area, plus, 1 space per 1,700 square feet of other building gross floor area
Manufacturing, light	1 space per 350 square feet of office area; plus, 1 space per 1,700 square feet of other building gross floor area
Marina	1 space per 300 sq. ft. of building gross floor area
Massage parlor	1 space per 400 square feet of building gross floor area; plus, 1 space for each therapy room
Mechanical rides or attractions	1 space per three thousand (3,000) square feet of outdoor active recreation space, plus, any additional spaces required for ancillary uses such as, but not limited to, game centers, theaters and billiard halls.
Medical clinic	1 space per exam room; plus, 1 space per 400 square feet of building gross floor area

White County Zoning Ordinance Parking and Loading Standards

Use Category	Minimum Parking Requirements
Medical Emergency/Immediate Care Facility	1 space per exam room; plus, 1 space per 400 square feet of gross floor area
Medical, Mental Health Facility (or Psychiatric Hospital)	1 space per 4 beds; plus, 1 space per 400 square feet of gross floor area
Medical office	1 space per 400 square feet of building gross floor area; plus, 1 space for each exam room
Meterological tower	None
Miniature golf facility	1; plus, 1 spaces per golf hole
Model home or apartment	2 spaces (per residential standards)
Modular home	2 spaces (per residential standards)
Motel	1 space per 400 square feet of general office and maid floor area; plus, 1 space per sleeping room
Motorcycle sales	See "Automobile sales"
Museum/gallery	1 space per 250 square feet of exhibit area
Neighborhood facility	1 spaces per 200 sq.ft. of building gross floor area
Newspaper publishing	1 space per 400 square feet of building gross floor area
Newspaper stand	None
Non-profit/charitable organization	1 space per 400 square feet of building gross floor area
Nursery, horticultural	1 space per 400 square feet of building gross floor area
Nursing home	1 space per 3 sleeping rooms; plus, 1 space per 1,000 square feet of building gross floor area
Office Building	1 space per 300 square feet of building gross floor area..
Office research park	3 spaces per 1,000 sq.ft. of building gross floor area up to 20,000 sq.ft.; plus, 2 spaces per 1,000 sq.ft. of building gross floor area greater than 20,000 sq.ft.
Orchard/Vineyard	1 space per 400 square feet of building gross floor area

White County Zoning Ordinance Parking and Loading Standards

Use Category	Minimum Parking Requirements
Outdoor storage	See "Storage, Outdoor)
Park, private or public	Requirements as provided in Section 8.11.5
Parking lot	As designed
Parking lot event, special	None
Parking structure	As per the structure's site plan
Peddler	See "Sidewalk vendor"
Personal/Professional Services (includes social services)	1 space per 350 square feet of building gross floor area
Petting zoo	None
Pole barn	2 spaces per barn when it is the lone structure on the lot; otherwise none.
Printing, lithographing, publishing or photography	1 space per 400 square feet of building gross floor area
Race track	1 space per 4 seats at maximum capacity
Radio, TV, music studio/station	2 spaces; plus, 1 space per 400 square feet of building gross floor area.
Railroad facilities	1 space per 400 square feet of building gross floor area
Raising and breeding of non-farm fowl or animals, commercial	None
Recreational facility, indoor	1 space per 4 seats or 1 space per 4 people at maximum capacity (whichever is greater)
Recreational facility, outdoor	If not delineated specifically, 30 per playing field or 1 space for each 4 guests at peak capacity.
Recreational vehicle park	1 space per 150 sq ft of office space, plus, 2 loading spaces.
Recreational vehicle sales	1 spaces per 400 sq.ft. of building gross floor area; plus, 2 spaces per service bay.
Recycling facility	1 space per 400 square feet of building gross floor area; plus, 1 space for each vehicle used in the operation of the business

White County Zoning Ordinance Parking and Loading Standards

Use Category	Minimum Parking Requirements
Recycling satellite, private	1 loading/unloading space per container
Recycling satellite, public	1 loading/unloading space per container
Refinery, petroleum	1 space per 400 square feet of building gross floor area
Religious institution	1 space per 4 seats in main auditorium
Rendering plant	See "Manufacturing, Heavy)
Residential subdivision	As required by approved plat
Resort	1 space per 300 square feet of general office and maid floor area; plus, 1 space per sleeping room
Restaurant	One (1) parking space for each 50 square feet of building gross floor area; plus, one (1) space for each (100) square feet of outdoor dining and entertainment area.
Restaurant, drive-thru	1 space per 300 sq.ft. of building gross floor area
Retail establishment (0 to 99,999 gsf)	1 space per 150 sq.ft. of building gross floor area
Retail establishment (100,000 gsf or more)	1 space per 150 square feet of building gross floor area
Retail, temporary	None
Retreat	Requirements as provided in Section 8.11.5
Sales office/dwelling unit	See Home Occupation
Sawmill	1 space per employee on the largest shift
Scrap metal yard	1 space per 400 square feet of building gross floor area
Sewage treatment plant, private	1 space per 400 square feet of building gross floor area
Shooting range, indoor	1 space per 400 square feet of building gross floor area plus, 1 space per 3 shooting stalls/positions
Shooting range, outdoor	1 space per 400 square feet of building gross floor area plus, 1 space per 3 shooting stalls/positions

White County Zoning Ordinance Parking and Loading Standards

Use Category	Minimum Parking Requirements
Sidewalk vendor/peddler	None
Slaughter house	1 space per 400 square feet of building gross floor area
Solar engery system	None
Solar farm	None
Sporting event	None
Stable or boarding, commercial	1 space per 400 square feet of building gross floor area
Stable or boarding, private	1 space per 400 sqaure feet of building gross floor area
Stadium/coliseum/athletic field, commercial	1 space per 2 seats of spectator capacity
Stockyard	Requirements as provided in Section 8.11.5
Storage, commercial boat (See Boat Storage, Commercial)	
Storage, bulk	None
Storage, commercial	None.
Storage facility, self service	1 ADA space for each two required ADA accessible units
Storage, outside	None
Storage, personal	2 spaces when not associated with a residential dwelling
Storage tank, fuel (commercial)	1 space for maintenance
Storage tank, fuel (private)	none
Storage tank, gas (commercial)	1 space for maintenance
Storage tank, gas (private)	None
Storage tank, oil (commercial)	1 space for maintenance
Storage tank, oil (private)	None
Storage tank, water/water tower	1 space for maintenance

White County Zoning Ordinance Parking and Loading Standards

Use Category	Minimum Parking Requirements
Storage yard	1 space per vehicle at maximum capacity use
Subdivision, residential major	Per subdivision plat
Subdivision, business/industrial	Per subdivision plat
Swimming pools, private	None
Tattoo parlor (see personal/professional services)	
Taxicab Company	1 space per taxicab affiliated with the service; plus, 1 space per 200 square feet of general office area.
Tavern	One (1) parking space for each fifty; (50) square feet of building gross floor area; plus, one (1) space for each two hundred (200) square feet of outdoor dining and entertainment area
Theater, indoor	Requirements as provided in Sections 8.4, 8.5 and 8.11.3
Theater, outdoor	1 space per 400 square feet of building gross floor area; plus, 1 space for each 4 patrons as maximum capacity
Therapeutic horseback riding/equine-assisted activity/adaptive riding	2 spaces; plus, 1 space per animal at maximum capacity
Ticket booth	None
Transfer facility, solid waste	1 space per 400 square feet of building gross floor area
Transfer facility, other	1 space per 400 square feet of building gross floor area
Truck freight terminal	1 space per 400 square feet of building gross floor area
Truck stop	1 space per 300 sq.ft. of building gross floor area
Truck wash	1 space per 400 square feet of building gross floor area
Utility facility, public	1 space per 1,000 square feet of building gross floor area other than office area; plus, 1 space for each vehicle used in conjunction with the facility's use plus 1 space per 200 square feet of general office area.

White County Zoning Ordinance Parking and Loading Standards

Use Category	Minimum Parking Requirements
Utility facility, private	1 space per 1,000 square feet of building gross floor area other than office area; plus, 1 space for each vehicle used in conjunction with the facility's use plus 1 space per 200 square feet of general office area.
Vacation home/holiday home/holiday apartment/tourist home	1 space per bedroom; plus, 1 space for each room where sleeping accommodations are accessible or may be made
Veterinary clinic/hospital	1 space per 400 square feet of building gross floor area
Warehouse	1 space per 400 square feet of building gross floor area
Water and sewage distribution and pumping facilities (For water and treatment plants, see Utility Facility, Public)	None
Water park	1 space per three thousand (3,000) square feet of outdoor active recreation space, plus, any additional spaces required for ancillary uses such as, but not limited to, game centers, theaters, restaurants and billiard halls.
WECS - commercial	None
WECS – Micro	None
WECS – non-commercial (all heights)	None
Welding shop	1 space per 400 square feet of building gross floor area
Wholesale business	1 space per 400 square feet of building gross floor area
Winery	1 space per 300 sq. ft. of building gross floor area
Wireless facility, communications	None
Wireles facility, micro	None
Wireless facility, small cell	None

Use Category	Minimum Parking Requirements
Youth/juvenile detention center	1 space per 400 square feet of building gross floor area excluding area dedicated to holding cells or rooms; plus, 1 space per 3 holding cells or rooms designed for temporary occupancy
Zoo, petting	1 space per 50 sq.ft. of exhibition area
Zoo/zoological garden/zoological park	1 space per 3,000 sq.ft. of total land area

- (1) A facility is allowed to utilize two on-street parking spaces toward satisfying their off-street parking requirement as long as the street abutting the property allows on-street parking and this allowance does not conflict with any other standard or requirement of this Ordinance.
- (2) The following standard shall be used anytime outdoor seating is provided but not accounted for in Table 8.6 above. A parking space allowance for outdoor seating is one parking (1) space for every four (4) outdoor seating positions created by a seat or sixteen (16) inches of bench space.

CHAPTER 9 LANDSCAPING STANDARDS

9.0 PURPOSE AND INTENT

The purpose of this Chapter is to establish minimum standards for the provision, installation and maintenance of landscaping and buffering to increase the compatibility of development with the natural environment and/or physically separate and visually screen adjacent uses and zoning districts that are not fully compatible. All B-1 and B-4 District parcels are exempt from the Standards of this Chapter unless specifically provided for herein.

9.1 APPLICABILITY

Unless otherwise stated, this Chapter shall apply to all public, private, and institutional developments constructed after the adoption of this Ordinance.

9.2 LANDSCAPE PLAN REQUIREMENT

A landscape plan shall be required for proposed developments in the following situations:

- A. Commercial, new development of land;
- B. Commercial, redevelopment of land which includes a rezoning of the property and where the property abuts a non-compatible land use;
- C. Industrial, new subdivisions; or
- D. New, multi-family residential projects.

Site elements such as outdoor lighting, signage, trash receptacles and fencing shall be considered integral parts of a landscape plan. The end result should be a plan, which incorporates a pleasing appearance from both within and looking at the subject site. All landscape plans shall conform to the provisions of this Chapter.

A site shall be considered a "redevelopment" when costs of a project exceed 50% of the assessed value of all land improvements as provided for by the County Assessor's Records.

9.2.1 Preparation

When a landscape plan is required it shall be submitted by the applicant and prepared by an experienced landscape design professional unless, at the discretion of the Executive Director, the required landscape information is provided on a site plan prepared by a professional engineering firm, architect, design company or equivalent professional or professional firm.

9.2.2 Content

All landscape plans submitted for approval as a component of a required site development plan shall show the entire lot drawn to scale and shall contain the following information:

- A. Name and address of the owner, developer, and plan preparer, the date the plan was prepared, scale, and north arrow.
- B. Location and dimensions of all existing and proposed structures, parking lots and driveways, roadways and right-of-ways, sidewalks and other designated pedestrian or bicycle pathways, ground signs, refuse disposal areas, bicycle parking areas, freestanding electrical equipment, man holes, meters, recreation facilities, utility lines and easements, freestanding structural features, any existing trees or shrubs that will be retained and other landscape improvements, such as earth berms, walls, fences, screens, sculptures, fountains, street furniture, lights, and courts or paved areas.
- C. Location, quantity, size, and common name of all proposed planting materials.
- D. Location of barriers to be placed at or beyond the drip line of any trees to be preserved, and the type of material to be used for the barrier.
- E. Planting and installation details as necessary to ensure conformance with all required setbacks.
- F. All drawings shall be at a scale not smaller than one inch equals fifty feet (1"=50') with a scale of one inch equals thirty feet (1"=30') being preferred. Any other scale must be approved by the Executive Director. No individual sheet or drawing shall exceed twenty-four inches by thirty-six inches (24" x 36").

9.3 GENERAL LANDSCAPING REQUIREMENTS

9.3.1 Agricultural Districts

A. A-1 District

An A-1 District utilized for farming, R-1, single family residential use or single and two residential use, shall be considered a base zoning use and shall not be required to have a buffer yard.

B. A-2 District

In any A-2 District, a buffer shall be required for any structure proposed within two hundred (200) feet of a public right-of-way or any non-compatible zoning district. Said buffer shall be installed and planted as prescribed in Table 9.1, Landscape Requirements.

9.3.2 Placement of trees

All plantings shall be setback from the property line as determined by the anticipated drip line of the mature planting. In no instance shall a tree be placed or allowed to grow where the drip line overextends the property line of the property on which it is planted.

9.3.3 Vision clearance areas

In no instance shall a planting obstruct the sight lines between streets and access drives and parking aisles near entries and exits in accordance with the standards provided in Chapter 3, Specific Use Requirements and Performance Standards, Vision Clearance Triangle, of this Ordinance.

9.3.4 Parking lot landscaping requirements

In the event that a new development provides a parking lot section of fifty (50) spaces or more, at least four percent (4%) of the total area of the proposed parking lot shall be used for landscaping and buffering. For Industrial zoning district properties, ie. I-1, I-2 & I-3, parking lot spaces dedicated to employee parking are exempt from the requirement of this sub-section. In addition:

A. Minimum number of plantings

A minimum of one (1) tree shall be planted for every twenty-five (25) parking spaces. Said tree shall be placed in a tree island located within the parking lot. Where no additional buffer is required, there shall be one (1) additional tree, of an ornamental variety, planted every 50 linear feet of parking lot perimeter.

B. Tree islands

Tree islands shall be installed intermittently, or consecutively, to protect plantings from vehicles and foot traffic and to accommodate a tree root system. Said islands shall have a minimum length equal to that of a parking stall, and a minimum width of four (4) feet.

C. Unimproved disturbed ground

All unimproved disturbed earthen areas shall be replanted, restored, or otherwise protected from erosion.

D. Maintenance

All ongoing maintenance, including the replacement of any dead or otherwise unhealthy planting materials, shall be the responsibility of the property owner.

9.3.5 Protection of landscaped areas

All landscaped areas, including tree islands, shall be separated from vehicular traffic movement by a concrete, chair back curb or wheel stops.

A. Curbing

In instances where a curb is used, said curb shall have a minimum height of four (4) inches, measured from the finished surface grade of the parking lot. All tree islands shall be separated from vehicular traffic movement by a curb as described above. Roll curbs are hereby expressly prohibited from use in this application.

B. Wheel stops

In instances where landscaped areas are separated from vehicular traffic movement through the use of wheel stops, said wheel stops shall have a minimum height of four (4) inches, measured from the finished surface grade of the parking lot. All wheel

stops shall be properly anchored and continuously maintained in a good condition. Wheel stops shall not be placed in any location designed for pedestrian circulation.

9.3.6 Screening of outdoor activities

A. Non-residential activities

All non-residential manufacturing, assembling, construction, repairing, and maintenance which take place on a regular basis outside of a primary or accessory structure which is within fifty (50) feet of a public right-of-way or a residential district shall require an approved landscape screen as prescribed by Table 9.1, Landscape Requirements.

B. Outdoor storage

All outdoor storage shall be completely enclosed by a fence with a minimum height of six (6) feet which has an access gate that remains closed and locked except when attended by authorized personnel. With the exception of the access gate, the enclosure shall be screened by plantings on all sides. Said fence and plantings shall meet the following requirements:

1. Fence

The security fence shall be opaque and constructed of a material. Said materials shall be of a color or colors that are compatible with the natural environment.

2. Plantings

Evergreen plant materials shall be located to as to create a dense screen. Said plantings shall reach a mature height of at least six (6) feet.

9.3.7 Screening requirements for wireless communications facilities

A communications tower base and all accessory equipment shall be enclosed by a security fence of at least six (6) feet in height with an access gate that remains locked except when attended by authorized personnel. In addition, the enclosure shall be screened on all sides; and both the fence and screening shall meet the following provisions:

A. The security fence shall be opaque and shall be of a color or colors that are compatible with the natural environment.

B. The screen shall be of dense evergreen plant material with a mature height of at least six (6) feet.

9.3.8 Screening of refuse and recycling areas

Non-residential and multi-family refuse disposal dumpsters shall be screened on three (3) sides by the construction of a permanent opaque wall or fence. Said wall or fence shall be constructed of one (1) or more of the following materials: wood, vinyl, brick, or masonry. Said wall or fence shall be a minimum of six (6) feet in height and a maximum of eight (8) feet in height. The unscreened side shall provide for access to the dumpster and shall be gated. Said gate shall be opaque constructed of one (1) of the following materials: wood, vinyl, or slated chain-link gate. The access gate should be located to

minimize visibility from any public road or right-of-way and maximize accessibility by the property occupant. All access gate locations must be approved by the Executive Director to achieve this balance prior to the issuance of an Improvement Location Permit.

9.3.9 **Screening requirements for service structures**

For the purposes of administering and enforcing this Chapter, service structures in a B-2, B-3, I-1, I-2 or I-3 zoning district shall include, but are not limited to: Propane tanks, electrical transformers, utility vaults which extend above the ground, ground mounted utility equipment and any electrical or other equipment or elements providing service to a building or a site. No service structure shall be visible from an adjacent residential development or public right-of-way. Any service structure that can be seen from the first floor of a residence or from any street shall be screened. Structures may be grouped together; however, screening height requirements shall be based upon the tallest of the structures.

9.3.10 **Detention/retention basins and ponds**

Detention/retention basins and ponds shall be vegetated. While not required, developers are strongly encouraged to shape each pond so that it replicates a natural form, rather than a geometric object, such as a square, rectangle or triangle.

9.3.11 **Preservation**

The minimum number of plantings required by this Ordinance may be modified in any situation where existing trees and vegetation are preserved. A credit for the preservation of desirable undergrowth, shrubs and trees may be awarded on a case-by-case basis at the discretion of the Executive Director or the Area Plan Commission. Such allowance shall be in writing and included as part of the Improvement Location Permit file for the site.

9.4 **APPROVED LANDSCAPING MATERIALS**

Appendix C, Table of Recommended Plant Materials, contains tables that specify the approved trees, shrubs, and ground cover to be used to meet the landscaping and buffering requirements of this Chapter. Plant materials not listed on the tables will be assigned a classification based on height, spread, and/or crown at maturity, using the best available resources to determine mature characteristics. Appendix C should be interpreted as follows:

9.4.1 **Trees**

Trees are grouped into three (3) categories: shade trees, ornamental trees; and evergreens. Trees proposed to meet the requirements of this Chapter may be selected from Appendix C: Table C-1 and Table C-2.

9.4.2 Shrubs and vines

Shrubs are grouped by height: small shrubs (<2'), medium shrubs (2'-6'), and large shrubs (>6'). Shrubs and vines proposed to meet the requirements of this Chapter may be selected from Appendix C: Tables C-3 and C-4.

9.4.3 Ground cover

Except where occupied by planting beds or mulch trails, all buffer areas shall be planted with grass, sod or another comparable ground cover.

9.4.4 Screening materials

Materials used for screening may consist of both natural and man-made objects, provided that said materials create a continuous visual screen. The following screening types may be used:

A. Plant materials

Plant materials shall be characterized by dense growth and shall form an effective year-round screen within three (3) years of the time of planting.

B. Fences and walls

Fences and walls used for screening shall be one hundred percent (100%) opaque (solid) and made of wood, vinyl, or masonry materials. Refer also to Table 9.1, Landscape Requirements.

C. Earthen berms

Earthen berms shall have a maximum slope of 3:1 and a maximum height of ten (10) feet in all zoning districts except I-1, I-2, I-3, A-2 or on any property where extractive manufacturing is conducted, in which case berms shall be allowed to a height of twenty (20) feet. With the exception of a mulch trail, all earthen berms shall be entirely vegetated with an appropriate ground cover within two (2) years of the time of planting.

9.5 **INSTALLATION AND MAINTENANCE**

All plant materials shall be nursery grown and conform to the requirements described in the latest edition of the American Standard for Nursery Stock, as amended from time to time by the American Association of Nurserymen.

9.5.1 **Trees**

All trees planted as part of a required landscaping plan shall conform to the following standards and provisions at the time of planting:

- A. Caliper measurements shall be taken six (6) inches above grade for trees under four (4) inches in diameter and twelve (12) inches above grade for trees four (4) inches or larger in diameter.
- B. Minimum branching height for all shade trees shall be four (4) feet.
- C. Minimum size for shade trees shall be two and a half (2 1/2) inches in caliper.
- D. Minimum size for ornamental trees shall be one and one half (1 1/2) inches in caliper
- E. Minimum size for evergreen trees shall be four (4) feet in height.

9.5.2 **Responsible party**

For the purposes of administering and enforcing this Ordinance, the owner of the property shall be responsible for the maintenance, repair, and replacement of all landscaping materials on the premises. The owner shall further be responsible for ensuring that all landscaped areas are kept free of refuse and debris, and that any fence, wall or barrier that is required by this Ordinance is maintained in good repair.

9.5.3 **Dead, dying or damaged plant materials**

All plant materials that die shall be replaced with plant materials which conform to the standards of this Chapter within thirty (30) days of the plant material's death. If weather conditions inhibit installation of new plant materials the required landscaping shall be replaced with plant materials which conform to the standards of this Chapter within six (6) months of the plant material's death. Extensions of time may be granted by the Executive Director on a case-by-case basis.

9.6 **FENCING**

Anyone with the intentions to install a fence whose property is located in a Flood Hazard Area, regardless of zoning district or use, must obtain a permit from the Department of Natural Resources in addition to complying with the requirements of this Section.

Fences are allowed within any zoning district, provided that they are in conformance with the provisions of this Section. When not located in a Flood Hazard Area, fences used in conjunction with farming activities, parks or utilities shall be exempt from these regulations.

9.6.1 Construction materials

Unless otherwise specified by this Ordinance, all fences shall be constructed of wood, vinyl, wrought iron, chain link, stone/rock or masonry materials. In no instance shall a barb wire or electric fence be allowed in a residential district.

9.6.2 Height

Unless otherwise specified in this Ordinance, no fence shall exceed six (6) feet six (6) inches in height as measured from any grade point to the top of the fence or fence structure at that point.

9.6.3 Front yard limitations for residential uses

No fence taller than three and one half (3 ½) feet may be placed between the front of the primary structure, (the side where the address is required to be posted), and the road right-of-way. No fence that is more than fifty percent (50%) opaque may be placed within a front setback buffer. In the case of a lake area property, this front yard limitation applies only to the property lines which abut a road.

9.6.4 Decorative fences for residential uses

Fencing which is intended for decorative purposes only may be allowed on any part of a parcel, provided that it does not exceed three (3) feet in height.

9.6.5 Non-residential fences

1) Fences intended for use in conjunction with a business or industrial operation or for use by a branch of government and not exempted elsewhere in this Section, shall comply with Subsections 9.6.1, 9.6.2 & 9.6.3 of this section except that the fence must not encroach a front setback requirement.

2) Security Fences: Fences in a business (B-1, B-2, B-3 and B-4), industrial (I-1 and I-3) district or used by a branch of government, that are intended for security purposes shall only be allowed under the following conditions:

A. Such fences shall be allowed within a side or rear yard area, but shall be prohibited in a front yard setback;

B. The property owner or occupant must provide to the Executive Director, in writing, a justification of the need for a Security fence;

D. Security fences shall be of common chain link construction and may not be more than fifty (50) percent opaque (other materials may be used upon written approval by the Executive Director if, in the opinion of the Director, such materials are needed to accomplish the security objectives of the property owner or occupant and do not create an unsafe or nuisance condition);

E. Security fences shall not exceed eight (8) foot four (4) inches in height; and,

F. Barbed wire use shall not be allowed.

3) Fences for security purposes in an I-2 district may be placed in a rear, side or required front yard area subject to the following provisions:

- A. The fence is a minimum of fifteen (15) feet from the front property line;
- B. In no instance shall the fence exceed eight (8) feet four (4) inches in height, with the exception of fences with barbed wire. Fences with barbed wire may add up to three (3) strands of barbed wire on top of the fence for a total maximum fence height of eleven (11) feet; and,
- C. Security fences shall be of common chain link construction (other materials may be used upon written approval by the Executive Director if, in the opinion of the Director, such materials are needed to accomplish the security or nuisance objectives of the property owner or occupant) and may not be more than fifty (50) percent opaque

Security fences shall not be allowed in any R-1, R-2, R-3, R-4 or L-1 zoning district except in cases where the property is used by a branch of government.

9.6.6 Municipal Regulations

Any fence constructed on a property located within a City or Town boundary or within the defined limits of Buffalo or Idaville is, in addition to the requirements provided for elsewhere in this Section, required to comply with the following:

- A. Prior to initiating construction of any fence, other than those exempted in Section 9.6, a property owner or contractor must obtain an improvement location permit from the Area Plan Department;
- B. If your property all or partially lies within a Special Flood Hazard Area, you are required to obtain a permit from the Indiana Department of Natural Resources in addition to the local permit required by Subsection 9.6.6 A;
- C. Any fence on a property used for any purpose, other than single or two-family residential purposes, may not place any portion of the fence within a front yard setback unless specifically provided for elsewhere in this Chapter;
- D. Any fence or portion of a fence extending into a front yard setback may not be taller than three and one-half (3 ½) feet tall; and,
- E. No fence or portion of a fence extending into a front yard setback may be more than fifty (50) percent opaque.

Table 9.1: Landscaping Requirements

SUBJECT PROPERTY	MINIMUM WIDTH	LOCATION	REQUIRED PLANTINGS	DISTANCE FOR REQUIRED PLANTINGS
L-1	None	None	None	None
A-1	None	None	None	None
A-2 Applies to confined feeding operations only	20'	Along all lot lines excluding those lot lines abutting an Agricultural or Industrial district and excluding areas designed for ingress/egress access	Two (2) rows of staggered evergreens	One (1) tree every 20' along required property line(s)
RR	None	None	None	None
R-1	None	None	None	None
R-2	None	None	None	None
R-3	Option 1: 30'	Options 1, 2 or 3: Along all side and rear yard lot lines	Option 1: One (1) tree and three (3) large shrubs	Option 1: Every fifty (50) linear feet along required property line(s)
	Option 2: 10'		Option 2: Solid screening at least six (6) tall from Appendix C-3	Option 2: Entire length along required property line(s)
	Option 3: 5'		Option 3: Solid Fence at least six (6)' tall, no more than eight (8)' tall	Option 3: Entire length along required property line(s)
R-4	Option 1: 30'	Options 1, 2 or 3: Along all side and rear yard lot lines	Option 1: One (1) tree and three (3) large shrubs	Option 1: Every fifty (50) linear feet along required property line(s)
	Option 2: 10'		Option 2: Solid screening at least six (6)' tall from Appendix C-3	Option 2: Entire length along required property line(s)
	Option 3: 5'		Option 3: Solid Fence at least six (6) tall, no more than eight (8)' tall	Option 3: Entire length along required property line(s)
PUD	As prescribed by an approved PUD Ordinance			
B-1	As required by the Governing Jurisdiction			
B-2	10'	Along the side and rear property lines, with the exception of lot lines immediately adjacent to a Business, Industrial or Agricultural district, wherein no buffer is required	One (1) ornamental or evergreen tree & three (3) large shrubs; <i>plus</i> a solid eight (8)' privacy fence at the lot line of the rear and side yards when adjoining an "R" or "L" zoning district	Specified plantings: Every fifty (50) linear feet along required property line(s)
B-3	10'	Along the side and rear property lines entire perimeter, with the exception of lot line immediately adjacent to a Business, Industrial or Agricultural district, wherein no buffer is required	One (1) ornamental or evergreen tree & three (3) large shrubs; <i>plus, when adjoining an "R" or "L" zoning district, a solid eight (8)' privacy fence at the rear of the buffer area.</i>	Specified plantings: Every fifty (50) linear feet along required property line(s)
B-4	None			
	Option 1: 20'	Option 1 or 2: Along all side and rear yard lot lines, with the exception of lot lines immediately adjacent to another Industrial or	Option 1: Minimum eight (8) evergreen trees, and five (5) large shrubs; <i>plus, when adjoining an "R" or "L" zoning district, a solid eight (8)' privacy fence at the rear of the buffer area.</i>	Specified plantings: Every fifty (50) linear feet along required property line(s)

I-1	Option 2: 40'	Agricultural district, wherein no buffer is required	Option 2: Minimum four (4)' berm with one (1) shade tree, two (2) evergreen trees and ten (10) large shrubs; <i>plus, when adjoining an "R" or "L" zoning district, a solid eight (8)' privacy fence at the rear of the buffer area.</i>	
I-2	Option 1: 20'	Option 1 or 2: Along all side and rear yard lot lines, with the exception of lot lines immediately adjacent to an Industrial or Agricultural Industry (A-2) district, wherein no buffer is required	Option 1: Minimum eight (8) evergreen trees, and five (5) large shrubs; <i>plus, when adjoining an "R" or "L" zoning district, a solid eight (8)' privacy fence at the rear of the buffer area.</i>	Specified plantings: Every fifty (50) linear feet along required property line(s)
	Option 2: 40'		Option 2: Minimum four (4)' berm with one (1) shade tree, two (2) evergreen trees and ten (10) large shrubs; <i>plus, when adjoining an "R" or "L" zoning district, a solid eight (8)' privacy fence at the rear of the buffer area.</i>	
I-3	Option 1: 20'	Option 1 or 2: Along all side and rear yard lot lines, with the exception of lot lines immediately adjacent to an Industrial or Agricultural Industry (A-2) district, wherein no buffer is required	Option 1: Minimum eight (8) evergreen trees and five (5) large shrubs; <i>plus, when adjoining an "R" or "L" zoning district, a solid eight (8)' privacy fence at the rear of the buffer area.</i>	Specified plantings: Every fifty (50) linear feet along required property line(s)
	Option 2: 40'		Option 2: Minimum four (4)' berm with one (1) shade tree, two (2) evergreen trees and ten (10) large shrubs; <i>plus, when adjoining an "R" or "L" zoning district, a solid eight (8)' privacy fence at the rear of the buffer area.</i>	

No Principal or Accessory structures shall be allowed in a required buffer zone, other than fences.

CHAPTER 10 SIGN STANDARDS

10.0 PURPOSE AND INTENT

10.0.1 Purpose

The purpose of this Chapter is to regulate the size, height, construction, maintenance, limitations, restrictions and permit status of all outdoor signage. These regulations are required to assure the health, safety, convenience and general welfare of the public; to create an attractive and harmonious community; to protect property values; and to further the community's economic development objectives. All signs required by a compelling governmental interest are exempt from these standards. In an AED district, only a sign classified as a Ground Sign, Pole Sign, Electronic Messaging Sign, Multiple Entity Sign or ADA sign are subject to the regulations and permitting requirements of this Chapter.

10.0.2 Intent

It is the intent of these regulations to promote signs that are:

- A. Legible and appropriate to the activity to which they pertain;
- B. Not distracting to motorists or boaters so as to create a safety hazard;
- C. Constructed and maintained in a structurally sound and attractive condition; and,
- D. Preserving and enhancing the character and visual appearance of White County.

10.1 SIGN PERMITS

10.1.1 Sign permit requirement

Except as otherwise provided herein, all signs regulated by this Ordinance shall require a permit issued by the Staff. A sign permit shall not be required for a change in the face of a sign as long the new sign face is the same size or smaller than that of the replaced sign, located within the envelope of the replaced sign and is of comparable construction type.

10.1.2 Information required for sign permit

All applications shall be submitted to the Staff and shall be accompanied by any information the Staff determines is necessary to assure compliance with this Ordinance. This includes, but is not necessarily limited to, the following:

- A. A site plan, with descriptions showing the location of the sign which is the subject of the permit. The site plan shall also show the location of all existing and anticipated free-standing signs on the same property;
- B. Where applicable, certification that the proposed sign meets the standards specified in the National Electrical Code adopted by the State of Indiana, Underwriters Laboratory or equivalent lab or code standard. This

requirement may be waived by the Executive Director for signs which are pre-manufactured for promotional purposes, designed for wall mounting and are less than four (4) square feet in size (such as those used by bars and taverns);

- C. A drawing, sketch or picture showing the size and dimensions of the sign face, the sign content, the overall height and width of the sign including the sign structure. along with installation details both of the sign to it's supporting structure and the sign structure to the ground (if applicable).
- D. A description of the sign material;
- E. Method and type of illumination, when applicable;
- F. Mounting details, which must include the method and installation details of mounting the sign to its supporting structure along with installation details and how the structure will be secured in the ground (if applicable).

10.1.3 **Permit fees**

When required, all application fees shall be filed with the Area Plan Commission Staff as specified by the Official Fee Schedule. If any sign is hereafter erected, placed, installed or otherwise established on any property before obtaining a permit as required herein, it shall be considered a civil zoning violation of this Ordinance and subject to enforcement by the Staff.

10.1.4 **Expiration of permit**

A sign permit shall become null and void if installation of the sign has not been completed within six (6) months from the date the permit is issued. Any applicant who fails to complete their sign installation within the time period specified above must apply for a new permit. The permit tag must be properly mounted within seven (7) days from the date the sign installation is complete. Failure to properly mount the permit tag will be considered a civil zoning violation.

10.1.5 **Effect of sign permit issuance**

No permit for a sign issued hereunder shall be deemed to constitute permission or authorization to erect or maintain an unlawful sign, nor shall a permit issued hereunder constitute a defense in an action to abate an unlawful sign.

10.1.6 **Permit revocation**

The Executive Director is empowered to revoke a sign permit in the event that any of the following circumstances exist:

- A. A sign is being constructed or installed without any other permit required by this Ordinance; and/or,
- B. A sign is being constructed in violation of:
 - 1. The terms, conditions, or provisions of this Ordinance;
 - 2. The terms, provisions conditions, or commitments of a variance; and/or,

3. The terms, provisions, conditions, or commitments of a special exception use permit.

The stop work order shall be posted in a conspicuous place on the property on which the violation is located or occurring, or personally delivered to the owner, occupant, tenant or person in charge of the property.

10.2 GENERAL REQUIREMENTS FOR ALL SIGNS

The regulations of this Section are in addition to the district regulations imposed on individual sign types in a given district.

10.2.1 Display of permit

Each sign permit tag shall be permanently attached to the sign or mounting structure so as to be visible from the road unless an alternate location has been approved by the Staff.

10.2.2 Responsibility

The owner and/or tenant of the premises and the owner and/or erector of the sign shall be held responsible for any violation of these regulations.

10.2.3 Maintenance

All signs shall be maintained in good condition and appearance as determined by the Executive Director or Office Administrator. Lights for illuminated signs shall be maintained in good working order.

10.2.4 Removal

The Executive Director shall remove or cause to be removed, at the owners' expense, any sign erected or maintained in conflict with these regulations. Removal of a sign by the Executive Director shall not affect any proceedings instituted prior to removal of such sign. See Section 10.5.2 of this Chapter for removal details.

10.3 GENERAL SIGN REGULATIONS

The regulations of this section apply to all signs whether or not a permit is required and may not be deviated from without approval from the Area Board of Zoning Appeals or else as expressly allowed in this section.

10.3.1 Location

- A. No sign or sign structure shall be placed on private property without the written consent of the owner or agent thereof;
- B. No sign shall be placed on a utility easement or drainage easement, highway right-of-way or railroad right-of-way unless expressly allowed in this Chapter or by State or Federal law, rule or regulation;
- C. No sign or sign structure, other than official street or highway signs, shall be placed upon, over, or in any public right-of-way, unless expressly allowed in this Chapter;

- D. No sign or sign structure shall be erected at any location where it may interfere with, obstruct the view of, or be confused with any authorized traffic sign, signal or device. No sign or sign structure shall be located in such a manner as to materially impede the view of any street or highway intersection, or in such a manner as to materially impede the view of the intersection of a street or highway with a railroad grade crossing. See Chapter 3, Specific Use Requirements and Performance Standards, for requirements for visibility clearance areas at all intersections;
- E. No sign shall be permitted which is placed on any curb, sidewalk, post, pole, bollard, electrolier, hydrant, bridge, tree or other surface located on public property or in a public right-of-way, unless expressly allowed in this Chapter;
- F. No sign shall be attached to any utility pole or any other unapproved supporting structure unless expressly allowed in this Chapter;
- G. No sign structure shall be allowed to provide more than two sign faces unless specifically provided for elsewhere in this Ordinance or unless authorized by the Area Board of Zoning Appeals.

10.3.2 Sign projection

- A. All projection signs require a sign permit from the Area Plan Department;
- B. With the exception of wall signs, no sign shall project over a public right-of-way without express written permission of the County Commissioners, appropriate legislative body or unless expressly allowed in this Chapter. All such signs shall meet the developmental standards required for projection signs and require a permit unless expressly exempted from the permit requirement elsewhere in this Chapter;
- C. Awnings, canopies, marquees and projection signs shall be a minimum of eight (8) feet above any walkway and may not project more than two (2) feet above any roofline. No sign that is affixed to or painted upon the surface of an awning, canopy or marquee shall extend vertically or horizontally beyond the limits of the awning, canopy or marquee.

10.3.3 Movement or simulated motion

- A. No rotating beam, beacon or flashing illumination resembling any emergency light shall be used in connection with any exterior sign display;
- B. No utilization of any motion picture, laser or visual projection of moving images or copy unless expressly allowed elsewhere in this Chapter (for electronic messaging, see the Electronic Messaging subsection under Section 10.4);
- C. Changeable copy elements may be allowed as a component of any sign.

10.3.4 Prohibitions

- A. No sign shall make use of words, phrases, symbols or characters in such a manner as to interfere with, mislead or confuse motorists;

- B. No sign shall bear or contain statements, words or pictures which would violate the standards and definitions provided in IC 35-49-2-1, as amended from time to time;
- C. No sign shall contain advertising matter that is untruthful or misleading.

10.3.5 Emmissions

Signs which emit audible sound or visible matter are prohibited unless authorized by the Area Board of Zoning Appeals or elsewhere in this Chapter.

10.3.6 Visual impairment

Signs shall not hide or block any traffic or roadway sign, signal or device from view except in those circumstances where the Indiana Department of Transportation, county highway, a municipality street department, a public utility or a public emergency services organization authorize such blockage or hiding.

10.3.7 Obstruction

Signs shall not obstruct any door, fire escape, stairway or any opening intended to provide ingress or egress to any structure.

10.3.8 Prohibitions – State or Federal law or regulation

No sign shall be allowed which is in violation of any Federal or State law or regulation.

10.3.9 Sign Components

Any sign subject to a permit may be divided into two components or sections; one component/section which is fixed in face design and one which is variable to allow timely community notices or promotional messages. Each component must be defined at the time the application for permit is submitted.

10.4 ILLUMINATION

All illuminated signs shall comply with the illumination provisions of this Section.

10.4.1 National standards

All illuminated signs must meet the standards specified in the National Electrical Code adopted by the State of Indiana, as amended from time to time, or be certified by UL or equivalent lab certification.

10.4.2 Condition

The total number of illuminating elements shall be kept in satisfactory working condition or immediately repaired or replaced.

10.4.3 Reflection

The direct, non-reflected light from a primary light source shall not create a safety or traffic hazard.

10.4.4 Shielding

- A. The light from any illuminated sign shall be so shaded, shielded or directed that the light intensity or brightness will not be objectionable to the surrounding areas. No light shall shine directly onto adjacent property.
- B. No sign within fifty (50) feet of a residential district shall be illuminated unless the sign is visibly obstructed from view from said residential district. This restriction shall not apply to signs identifying residential subdivisions or multi-family developments. Signs for institutional uses in residential districts may be illuminated if they meet all the standards, regulations and conditions provided for in this Chapter.

10.4.5 Electronic Messaging (EM)

Portable and temporary electronic messaging signs are prohibited except in cases of utilization by a government agency or utility where safety, warnings or hazardous conditions are being conveyed.

Signs in commercial or industrial districts, where not prohibited elsewhere in this Chapter, may utilize electronic messaging, either alone or as a component of a larger sign as long as the sign meets all other standards, regulations and provisions of this Chapter as well as the standards below:

- A. Electronic messaging is not permitted in any residential district unless used for institutional or government purposes or unless authorized by the Area Board of Zoning Appeals.
- B. No flashing, strobing, scintillating or variance of light intensity effects is allowed if the effect takes place more than two (2) times per second.
- C. The design of the copy cannot be created in such a way as to be a distraction to motorist.
- D. Each message on the sign must be displayed a minimum of five (5) seconds.
- E. No electronic messaging may exceed a brightness level of three (3) foot candles above ambient light as measured using a foot candle meter or one hundred (100) feet from the sign face, whichever is least restrictive.
- F. The leading edge of any sign or portion of a sign using electronic messaging shall be a distance of one hundred (100) feet from any abutting residential zoning district.
- G. Any sign within five hundred (500) feet of a residential district or property used in any other district for residential purposes (does not apply to residences in a B-1 or B-4 districts) must be oriented so that the face of the sign runs parallel to the road.
- H. Any change of message must be accomplished immediately (point five (.5) seconds or less).

- I. The face of the sign shall be limited to one advertising message per duration of the display.
- J. No two EM signs may be any closer than one hundred (100) feet as measured from the centerline of each sign. Signs may be placed closer than one hundred (100) feet, if in the sole discretion of the Executive Director, such proximity will not create a nuisance, safety hazard or be distracting to pedestrians or the general neighborhood.
- K. No EM sign may be any closer than one hundred fifty (150) feet to any traffic signal as measured in a straight from the center line of the sign to the centerline of the closest traffic signal fixture.
- L. No EM shall be placed closer than three hundred (300) feet to the closest corner of any residential dwelling unit (excluding those in a B-1 or B-4 district).
- M. Operational limitation: Sign message displays shall be limited to static displays. Apparent motion of the visual message, caused by, but not limited to, the illusion of moving objects, moving patterns or bands of light, expanding, contracting or rotating shapes or similar animation effects shall be prohibited. Such restrictions apply to “traveling”, “scrolling” or “running” messages. No message may appear/disappear via a fade or dissolve effect. Full motion video or film display via an electronic file imported into the EM sign software or streamed in real time to the EM sign is prohibited. All EM Signs shall have automatic dimming controls either by photocell or via software settings, in order to bring the EM sign lighting level appropriate for usage. Each EM sign that is malfunctioning shall be turned off until such time that the sign is properly functioning. The design of the copy cannot be created in such a way as to be a distraction to motorists.

10.5 MAINTENANCE AND REMOVAL

10.5.1 Inspection

Signs may be inspected periodically by the Executive Director and/or his or her agent to ensure compliance with this and other ordinances of the County.

10.5.2 Removal of signs

The Executive Director may order the immediate removal of any sign erected or maintained in violation of this Chapter. The Executive Director may remove a sign immediately and without notice if, in his or her opinion, the condition of the sign is such as to present an immediate threat to the safety of the public. The owner shall pay all costs incurred by the County for removal and storage. Any sign removed by the Executive Director and/or his or her agent pursuant to the provisions of this Chapter shall be held by the County for redemption by the Owner for a period of ten (10) days, at which time the County shall dispose of it in any manner deemed necessary.

Any yard or disposable sign not having obtained proper permitting and which does not include an entity name, phone number and address maybe removed

immediately and without notice. Such signs will be held at the Area Plan Office for seven (7) days and available for pick-up by the sign owner or any other person associated with the signs advertising activity. After seven (7) days all such signs shall be disposed of in an appropriate manner.

10.5.3 **Maintenance**

All signs and components thereof shall be kept in good repair and in a safe, neat, clean and attractive condition. Failure to comply as determined by the Executive Director shall cause the sign to be subject to appropriate enforcement provisions.

10.5.4 **Abandoned signs**

Abandoned signs shall be removed in a time frame and as directed by the Executive Director at the sign and/or property owners' expense.

10.6 **DETERMINING THE MEASUREMENTS OF A SIGN**

The following standards and provisions shall apply to the measurement of any sign.

10.6.1 **Sign area**

The sign area shall be that area which is enclosed by the smallest circle, triangle, or rectangle that can be used to enclose all sign elements, excluding the supporting structure if said structure does not form a part of the sign face or the display. See an example in Figure 10.1, Determining the Measurement of a Sign. Where matter is displayed in a random manner without organized relationship of elements, or where there is reasonable doubt about the relationship of elements, each element shall be considered to be a single sign.

10.6.2 **Back-to-back signs**

Sign faces placed back-to-back, on a single structure, at an angle of fifteen (15) degrees or less, and not more than forty-two (42) inches apart, qualify as back-to-back signs. The sign area for back-to-back signs shall be computed by the greatest sign area of the largest sign face. Back to back signs shall be considered a single sign.

10.6.3 **Sign height**

The height of a sign shall be the distance measured from the average surface grade surrounding the base of a sign to the top of the highest element of the sign. If, at the discretion of the Executive Director, there is a significant difference between road grade and ground grade, the Executive Director may deviate by up to 20% of the allowable sign height.

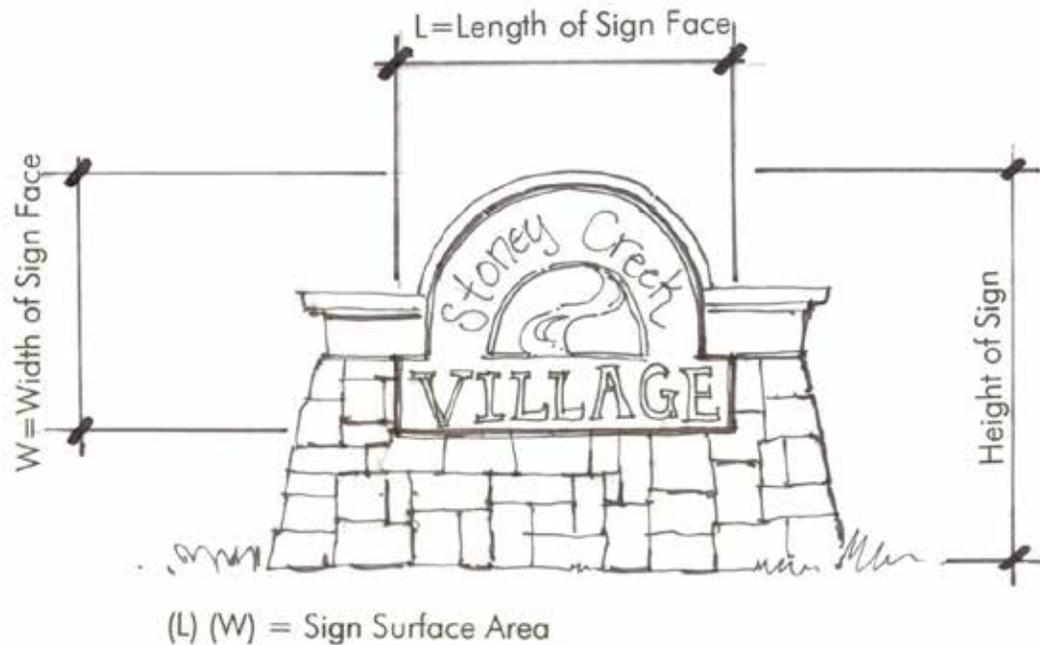

10.7 SIGN STANDARDS FOR RESIDENTIAL ZONING DISTRICTS

10.7.1 Applicable districts

The sign standards of this Section shall apply to all residential zones designated by this Ordinance.

10.7.2 L-1, R-1, R-2 & R-4 Residential Districts Used For Single Family Dwelling or Two Family Dwelling Purposes

A. General Sign Allowance

Each property meeting the criteria of 10.7.2 shall be provided a general sign allowance of forty-eight (48) feet, accumulative, subject to the following conditions and restrictions:

- 1) No individual sign may exceed six (6) square feet;
- 2) No sign may be placed in a legal rights-of-way;
- 3) No sign structure or sign-sign structure in combination may exceed six (6) feet in height;
- 4) No sign shall be illuminated, internally or externally;
- 5) No sign may be placed in a visual clearance area; and,
- 6) Each sign complies with the general sign regulations of this Ordinance and the specific sign regulations applicable to the sign type utilized.

Permanent or non-permanent off-premise signs are not permitted in these residential district & use combinations unless expressly allowed elsewhere in this chapter.

B. Permanent Identification Signs (Gateway Signage)

Any Major Subdivision or Manufactured Home Park is entitled to place no more than two (2) Permanent Identification Signs; also known as Gateway Signage, for any Subdivision or Manufactured Home Park subject to the following restrictions and conditions:

- 1) Each sign must meet all general sign regulations of this Ordinance and the specific sign regulations applicable to the sign type utilized as provided for in Table 10.1;
- 2) No sign may be illuminated in any fashion with the exception of exterior illumination directed at the sign face and in a manner which does not create a nuisance for pedestrian or vehicular traffic or an abutting property owner; and,
- 3) No sign may be placed in a visual clearance area.

10.7.3 R-3 & R-4 Residential Districts Used For Multi-Family Dwelling Units or Manufactured Home Park Purposes

General

A. General Sign Allowance

Each unit on a property meeting the criteria described in 10.7.3 shall be provided a general sign allowance of forty-two (42) feet subject to the following conditions and restrictions:

- 1) No individual sign may exceed six (6) square feet, unless expressly allowed elsewhere in this Ordinance;
- 2) No sign may be placed in a legal rights-of-way;
- 3) No sign structure or sign/sign structure in combination may exceed six (6) feet in height;
- 4) No sign shall be illuminated, internally or externally;
- 5) No sign may be placed in a visual clearance area; and,
- 6) Each sign complies with the general sign regulations of this Ordinance and the specific sign regulations applicable to the sign type utilized.

Permanent or non-permanent off-premise signs are not permitted in these residential districts & use combinations unless expressly allowed elsewhere in this chapter.

The sign allowance provided for in Subsection 10.7.3 B. following, is in addition to the signage allowance provided for in Subsection 10.7.3 A. above.

10.7.4 All Residential Districts Used For Institutional Purposes

In all residential districts used for institutional purposes, sign allowances, regulations and standards will be commensurated with those provided for Commercial and Industrial purposes but which must also meet any additional restrictions, regulations and standards expressly provided for elsewhere in this Chapter.

Table 10.1 – Permanent Identification Sign Regulations for All Residential Districts

Sign Type	Standards			
	Maximum Number of Signs	Maximum Sign Area (square feet)	Maximum Height (feet)	Setback From Right of Way to leading edge of sign (feet)
Ground Signs	2 per 20,000 square feet of parcel area	150	6	10
Wall Signs	1 per building per entrance	40; for home occupations see restrictions in Zoning Ordinance Section 3.1.2 F	Shall not exceed beyond the roofline	N/A
Pole Signs	1 per 20,000 square feet of parcel area	90	25	10

10.8 STANDARDS FOR COMMERCIAL AND INDUSTRIAL ZONING DISTRICTS

10.8.1 Applicable districts

The sign standards of this Section shall apply to all commercial and industrial zoning districts designated by this Ordinance for the specified sign types. Other sign types may be used when provided for elsewhere in this Chapter.

Table 10.2 – Sign Regulations for Commercial and Industrial Districts

Permitted Signs	Maximum Number of Signs	Maximum Sign Area (square feet)	Maximum Height (feet)	Setback From Right of Way to leading edge of sign or sign structure , whichever is most restrictive (feet)	Other Limitations
<p>Wall Signs Including Awning, Canopy and Marquee Signs</p> <p>NOTE: See below for requirements specific to I-3 Districts</p>	Not Applicable	Not Applicable	Shall not exceed 2 feet beyond the roofline or extend past any side or bottom wall perimeter	Not Applicable	No sign shall be allowed if, at the discretion of the Executive Director, it would create a nuisance to a residential district. If the sign extends more than 3” from the mounting surface it must be placed a minimum of 8’ above grade.
Ground Signs	1 per parcel plus one additional sign per each 200’ of parcel road frontage	150	8	10	See above

Pole Signs *	1 per parcel plus one additional sign per each 200' of parcel road frontage	90	25	10	See above
Electronic Messaging Signs	1 per parcel plus 1 additional sign per each 200' of parcel road frontage	100	Maximum height shall be restricted based on the sign type.	Setbacks shall be applied based on the sign type.	Must satisfy all requirements applicable to Electronic Messaging Signs found elsewhere in this Ordinance
Vehicle or Trailer Signs	1 on each hood, trunk or roof or side vehicle surface; 1 on each trailer surface other than the under surface	16 per sign	No more than 2 feet above the roof surface	Not Applicable	Applies only in cases not exempted in Section 10.12
Multiple Entities	1/300 feet Measured radially	60 per sign face; 1 sign face per Entity	40	10	See above
Roof Signs	Per BZA Approval	Per BZA Approval	Per BZA Approval	Per BZA Approval	Only permitted with approval from the Area Board of Zoning Appeals

NOTE: All commercial and industrial signs can be divided into two sections to allow accommodation of one permanent sign component and one replaceable sign component as long as the construction and sign type meet the standards, regulations and provisions of this Chapter and the replaceable component is utilized to promote or make the public aware of community activities or achievements.

* Poles signs may be placed within a vision clearance triangle and long as the sign meets the setback provisions listed in Table 10.2, no part of the physical sign falls within the visual clearance area, each pole would fit within a six (6) inch diameter envelope and, in the sole opinion of the Executive Director, neither the sign nor the sign structure will create a nuisance or safety hazard.

Limitations:

- A. Any sign which is illuminated or which uses accessory illumination must comply with all lighting and illumination standards found elsewhere in this Chapter.
- B. Multiple entity signs may only advertise, promote or identify entities which are located on the common parcel of land as that of the sign.

10.8.2 I-3

- A. In any I-3 District, wall signs must meet the following requirements:
 1. All Wall signage, excluding incidental signage necessary for the customer, visitor, vendor or traffic management of the site, must be incorporated into the building façade and are restricted to the portion of the building which faces a public right-of-way;
 2. Wall signage may not be painted directly onto the building elevation;
 3. Wall sign designs shall be consistent in style and scale with its associated structure; and
 4. Individually illuminated channel letters are preferred, back-lit internally illuminated box signs are not allowed.

10.8.3 Shared advertising signs

- A. Shared advertising signs (see Figure 10.2) shall comply with the State of Indiana Advertising Control Manual, as amended from time to time.

Figure 10.2 - Shared Advertising Sign

10.8.4 Roof Signs

A. Standards

Roof signs are allowed only upon the applicant's demonstration to the Board of Zoning Appeals that:

1. The roof signage is necessary due to alternative signage not being adequate to serve the advertising needs of the establishment requesting the sign;
2. The applicant provides sign installation and mounting details which the Board deems to be reasonably safe and secure (engineering certification may be required); and,
3. The applicant provides convincing evidence that the sign will not create a visual nuisance or distraction to neighboring properties or passing vehicular or pedestrian traffic.

B. Limitations & Restrictions

1. Roof signs may not be electrical nor utilize any electronic, LED or similar type components;
2. May not be lighted by any internal or external source; and,
3. May not be located so that any edge or component of the sign is any closer than one foot to any roof peak, valley or edge.

10.9 OFF-PREMISE SIGNS

10.9.1 State permitting compliance

Off-premise signs and billboards located along an Interstate, Federal-aid Primary Highway as it existed on June 1, 1991, or any other highways that are on the National Highway System, must meet the regulations specified in the "State of Indiana Outdoor Advertising Control Manual" as amended from time to time (See IAC 7-3-5 Territory to which article applies), **in addition to** the requirements provided for in this Ordinance.

10.9.2 Billboards, Location

A. Prohibitions

Traditional billboards are expressly prohibited in the following locations:

1. Within the corporate limits of the City of Monticello;
2. In any I-3 zoning district;
3. On any parcel abutting US Hwy 24 between County Road 1200 W and 1000 W in Princeton Township, White County, Indiana; and,
4. Within one thousand (1,000) feet of the US Hwy 24 ROW between County Road 1200 W and 1000 W in Princeton Township, White County, Indiana.

Digital billboards are expressly prohibited in the following locations:

1. Within the corporate limits of any White County Municipality or within one thousand (1,000) feet of any corporate municipality line;
2. Within the defined limits of Buffalo or Idaville as delineated on the County GIS mapping system or within one thousand (1,000) feet of their defined limits;
3. On any parcel abutting US Hwy 24 between County Road 1200 W and 1000 W in Princeton Township, White County, Indiana; and,
4. Within one thousand (1,000) feet of the US Hwy 24 ROW between County Road 1200 W and 1000 W in Princeton Township, White County, Indiana.

Billboards may be allowed in any A-1, A-2, B-2, B-3, I-1 or I-2 zoning district, provided they meet the specifications and requirements of this Chapter and are outside the boundary of any of the prohibited areas described above.

10.9.3 Billboards, Spacing and Size, Lighting

A. Sign spacing

No billboard shall be placed closer than one thousand (1,000) feet to any other billboard. This distance is to be measured radially from the center of the sign.

B. Total sign area

The area for any billboard shall be a minimum of three hundred (300) square feet and a maximum of four hundred fifty (450) square feet per advertising sign face. All extensions to the sign or any advertising message or copy on the sign structure shall be included as part of the sign's total area.

C. Sign height

The maximum height of any billboard shall be forty-five (45) feet as measured from grade to the top of the sign or sign structure, whichever provides the greatest height.

D. Separation from other uses

The minimum distance between any billboard and any residential district, public institution, school or church shall be one thousand (1,000) feet measured radially from the center of the sign.

E. Illumination

Lighting for all billboards shall be internal or external and directed against the sign surface only.

F. Visual clearance

All billboards shall comply with the visibility clearance area provisions in Chapter 3, Specific Use Requirements and Performance Standards.

10.9.4 Billboards, Digital

Any digital billboard or billboard using LED or similar technology or any billboard depicting or using motion lighting must receive approval from the Area Board of Zoning Appeals prior to a sign permit being issued or initiation of construction.

10.9.5 Yard signs (off-premise only)

- A. A sign permit is required for all off-premise yard signs (a group of signs may be authorized under a single permit if they are identical in size and face). Fee will be based on volume.
- B. Yard signs shall not exceed six (6) square feet in sign area and five (5) feet in sign height and shall not be placed closer than fifty (50) feet to any other off-premise yard sign on the same parcel.
- C. All yard signs must display the permit number, the date the permit is issued, name of the business, the physical address of the business and a valid phone number for each sign attaching this information utilizing a permanent method of attachment. Date characters are to be a minimum of one-half (1/2) inch in height and a minimum of one-sixteenth (1/16) inch in character width.

- D. Yard signs shall be located in a reasonable and safe manner as determined by the Executive Director;
- E. Yard signs must be maintained and kept in good repair and must meet the construction/design standards provided in this section.
- F. Yard signs which do not comply with this section of the ordinance or any other requirement of this Chapter may be immediately removed by the Staff without notification to the sign owner or the property owner upon which the sign is placed and will subject the sign owner and the property owner to the Fine Schedule as provided for in Chapter 13 of this Ordinance. Removed signs shall be held at the Area Plan Office for seven (7) days before being destroyed if not collected by the sign owner or representative.

10.9.6 Disposable signs (off-premise only)

- A. A sign permit is required for all off-premise disposable signs (a group of signs may be authorized under a single permit if they are identical in size and face). Fee will be based on volume.
- B. Disposable signs shall not exceed four (4) square feet in sign area and three (3) feet in sign height and shall not be placed closer than fifty (50) feet to any other off-premise disposable sign on the same parcel.
- C. All disposable signs must display the permit number, the date the permit is issued, name of the business, the physical address of the business and a valid phone number for each sign attaching this information utilizing a permanent method of attachment. Characters are to be a minimum of one-half (1/2) inch in height and a minimum of one-sixteenth (1/16) inch in character width.
- D. Disposable signs may be displayed for a period not to exceed one hundred twenty (120) days unless expressly allowed in writing by the Executive Director.
- E. Disposable signs may not be utilized to identify a home occupation.
- F. Disposable signs shall be located in a reasonable and safe manner as determined by the Executive Director;
- G. Disposable signs must be maintained and kept in good repair and must meet the construction/design standards provided for in this section; and,
- H. Disposable signs which do not comply with this section of the ordinance or any other requirement of this Chapter may be immediately removed by the Staff without notification to the sign owner or the property owner upon which the sign is placed and will subject the sign owner and the property owner to the Fine Schedule as provided for in Chapter 13 of this Ordinance. Removed signs shall be held at the Area Plan Office for seven (7) days before being destroyed if not collected by the sign owner or representative.

10.9.7 Signs on farm property

- A. Farms shall be allowed to place one (1) permanent off-premise sign, regardless of parcel size, in addition to any billboard allowance, on its premises as long as such signage is in compliance with this Chapter.
- B. Each farm shall be allowed additional, permanent off-premise signs on each farm property as long as they are no closer than three hundred (300) feet from any other off-premise sign on the same parcel. This distance is to be measured radially from the center of the sign.
- C. Size and setbacks will be applied by sign type as provided elsewhere in this Chapter.

10.9.8 Other Off-Premise Signs

Off-premise wall, ground and pole signs are allowed in commercial and industrial districts, excluding I-3 districts, as long as they meet the limitations, regulations and restrictions of Table 10.2 and any other standards or regulations of this Chapter. Any quantity limitations delineated in Table 10.2 are applicable to off-premise and on-premise signs in total.

10.10 LEGAL NONCONFORMING SIGNS

Permanent signs which were lawful prior to the time this Chapter was passed or amended, but which would be prohibited, regulated, or restricted under the terms of this Chapter shall be deemed legal nonconforming signs. Any such sign shall be allowed to continue (be grandfathered) until such time a major change is made to the sign, at which time a sign permit is required and the sign must be brought into compliance with this Ordinance unless, in the sole opinion of the Executive Director, the change qualifies under Subsection 10.10.1. Major changes include changing the size, adding lights, reconstruction and/or relocation. For the purposes of administering and enforcing this Ordinance, signs of historic significance, as determined by the Executive Director, shall not be subject to the regulations of this Section.

Non-permanent signs shall not be granted grandfather status and shall be subject to current Ordinance requirements as amended from time to time.

10.10.1 Exception

A permanent sign undergoing a major change may be allowed to continue, if in the sole opinion of the Executive Director, the change results in a reasonable and appropriate reduction in nonconformance and the allowance would not be detrimental to the health, safety, welfare and common good of the community.

10.10.2 Maintenance and repair

Nothing herein shall prevent maintenance, repainting or normal repair of legally established nonconforming signs.

10.10.3 Improvements

Legally nonconforming signs may not be enlarged, extended, moved, modified, reconstructed or structurally altered except in accordance with this Chapter.

10.10.4 Destroyed or damaged

A legally nonconforming sign which is destroyed or damaged to an extent exceeding fifty (50) percent of its sign area, may not be altered, replaced, or reinstalled unless it is in conformance with this Chapter or qualifies for an exception under subsection 10.10.1 of this Chapter. If the damage or destruction is fifty (50) percent or less of the sign area, the sign may be restored to its original condition within a time frame established by the Executive Director.

10.11 PROHIBITED SIGNS

10.11.1 Search lights

Search lights shall be prohibited.

10.11.2 Tower & WECS signs

No sign shall be placed on any communication, radio or cell tower without the approval of the owner and the Staff. Signs on any Wind Energy Conversion System (WECS) shall not be permitted except those in compliance to the standards of Chapter 7 of this Ordinance.

10.11.3 Signs similar to emergency or traffic functions

Signs which, by reason of their size, location, movement, content, coloring or manner of illumination, may be confused with or constructed as a traffic control sign, signal or device, or the light of an emergency or road equipment vehicle, or which hide from view any traffic or roadway sign, signal or device are prohibited.

10.11.4 Signs which obstruct

Signs which obstruct any door, fire escape, stairway, sidewalk or any opening intended to provide air, egress or ingress for any building or structure shall be prohibited unless expressly allowed elsewhere in this Ordinance.

10.11.5 Other signs

Signs which are not included under the types of signs allowed in this Chapter are prohibited unless, in the sole discretion of the Executive Director, the prohibited sign is comparable to an allowed sign type and where such sign meets all standards and regulations of this Ordinance applicable to such sign type. Any decision of the Executive Director may be appealed to the Area Board of Zoning Appeals under the appeal provisions located in Chapter 12, Section 12.6 and upon payment of any appeal fees listed in the Area Plan Official Fee Schedule.

10.12 EXEMPT SIGNS

The following signs shall be exempt from the permit requirements of this Chapter unless specifically required below and as long as they comply with the restrictions and limitations contained in this Section and with any other applicable standards, restrictions, rules or regulations of this Chapter. No exempt sign may impede upon an ADA access route or, in the sole opinion of the Executive Director, create an

unreasonable circulation obstacle to those covered by ADA law, create a visual impairment or create a public nuisance.

Address identification regulations and standards can be found in Chapter 12, Section 12.16.

All exempt signs are restricted by the Visual Clearance Triangle regulations found in Chapter 3, Section 3.0.7 unless specifically exempted elsewhere in this Section.

INDEX:

<u>Sign Type</u>	<u>Section #</u>
A-frame and T-frame signs.....	10.12.15
Agricultural Land Signs.....	10.12.2
Barn Quilt Signs.....	10.12.21
Bench signs.....	10.12.18
Changeable Copy Signs, Portable.....	10.12.19
Community service central displays/Community Adoption Signs.....	10.12.17
Cylindrical Poles.....	10.12.1
Decorative Signs(Banners, lights, balloons, pennants and streamers).....	10.12.16
Disposable signs – on premise.....	10.12.12
Drive-through boards.....	10.12.3
Feather Flag Banners.....	10.12.4
Flags.....	10.12.5
Government signs.....	10.12.7
Historical location signs.....	10.12.6
Incidental Parking Lot Signs.....	10.12.9
Incidental Signage, Other.....	10.12.10
Integral Signs.....	10.12.8
Murals, Wall Graphics And Works Of Art.....	10.12.26
Natural Composit Signs.....	10.12.24
Neighborhood watch and similar community awareness signs.....	10.12.20
Park or athletic field fence signage, wall signage and scoreboard signage...	10.12.29
Public Signs.....	10.12.27
Retail Signage.....	10.12.23
Suspended signs.....	10.12.13
Utility Marker Signs.....	10.12.28
Vehicle Signs.....	10.12.25
Water Tower Signs.....	10.12.22
Window signs and signs viewable through a window.....	10.12.14
Yard Signs – on premise.....	10.12.11

10.12.1 Cylindrical Poles

Rotating or stationary cylindrical poles are exempt providing they meet the following standards:

- A. No cylindrical pole shall exceed fifty (50) inches in length;
- B. No cylindrical pole shall exceed six (6) inches in diameter;
- C. All cylindrical poles shall be attached by brackets to a building wall of the business for which the sign is representing;

- D. The top of the pole shall not extend above the roof line of the building to which it is attached;
- E. Such signs may move or rotate; and,
- F. May be illuminated as long as the illumination is, in the sole opinion of the Executive Director, adequately subdued to prevent a nuisance to neighboring properties.

10.12.2 Agricultural signs

Signs located on agricultural land (land used for Agricultural purposes) are exempt provided they are less than two (2) square feet in area and each sign maintains fifty (50) feet of separation between agricultural land signs. All other signs allowed on agricultural land must comply with the Standards and Regulations of Chapter 10 of this Ordinance.

10.12.3 Drive-through boards

Each drive-through establishment shall be allowed one (1) free-standing or wall mounted board per drive-through lane which shall not exceed forty-eight(48) square feet in area or eight (8) feet in height and shall be located adjacent to and oriented toward the drive-through lane. In addition, each drive through lane shall be allowed a separate speaker post in the drive-through area.

10.12.4 Feather Flag Banners

Feather Flag Banners (FFB) may be utilized in any zoning district designated as Commercial or Industrial as long as no two FFB's are located within any fifty (50) foot radius. The banners may be placed up to the right-of-way line or property line as long as the edge of the flag, when fully extended, does not cross any right-of-way or property line or into a Visual Clearance Triangle as defined in Section 3.0.7.

10.12.5 Flags

Flags that are not country, state or a unit of local government shall not exceed sixty (60) square feet. Flagpoles accompanying all flags shall meet all setback requirements and shall be limited to a height of thirty (30) feet in residential districts and forty (40) feet in non-residential districts. Government entities are expressly excluded from the limitations of this Section.

10.12.6 Historical location signs

Signs for property designated by the Federal, State or Local government as a historic location, site or landmark and which meet the definition of a Historical Sign as provided for in Chapter 14 of this Ordinance. Such signs are limited to the size restrictions and developmental standards for each sign type as specified in this Chapter and must remain outside a visual clearance triangle unless otherwise authorized in writing by the Executive Director.

10.12.7 Government signs

Signs utilized to fulfill essential functions of a governmental entity or department to promote safety, health and the general welfare of the community shall be allowed without regard to Appendix B: Bulk Use developmental standards or other

regulations contained within this Chapter due to the essential nature of their content. Signs placed by a government entity or department indicating a direction to a place, entity or activity or which identifies or memorializes a location or structure and which do not exceed four square feet in sign area are exempt from all regulations of this Chapter; otherwise, must be in compliance with the standards and regulations for the sign type utilized.

10.12.8 Integral signs

Signs carved into stone, concrete or similar material or made of bronze, aluminum, or other permanent type construction and made an integral part of a building

10.12.9 Incidental parking lot signs

Incidental parking lot signs are signs which are placed or displayed within a parking lot, near an ingress/egress route, along a driveway lane/maneuvering aisle or within a six (6) foot buffer area bordering the perimeter of a parking lot, driveway or facility loading/unloading area and which are intended to supply information to people using such lots including, but not limited to, liability, entering, exiting, entrance identifications and/or directional information to facilitate the safe movement of vehicles and pedestrians served by the parking area and the pedestrian circulation routes. Handicap parking and routing provision signs are also covered under this sub-section. Incidental parking lot signs shall not contain or display any advertising or commercial message other than an entities name or logo.

A. Location

These signs shall be installed in a mannuer which does not, in the sole opinion of the Executive Director, present a hazard to traffic entering or leaving the premises. No sign or part of a sign may extend into or over a right-of-way, ADA travel route, area utilized for parking or any other vehicle or pedestrian travel route.

B. Maximum Area

Incidental parking lot signs shall not exceed four (4) square feet in area.

C. Maximum Height

No incidental sign shall be exceed fifteen (15) feet in sign height.

D. Setbacks

Incidental parking lot signs shall be allowed without regard to setbacks but shall remain free of visual clearance triangle requirements and shall not be placed in a location which, in the sole opinion of the Executive Director, create a safety impairment.

E. Sign allowance

Incidental parking lot signs shall not count toward the total allowable signage for any parcel. Incidental parking lot signs may be internally illuminated but such lighting shall be subdued in a manner which does not create a light intensity nuisance.

F. Waiver

A property occupant may request, in writing, a waiver from the size and location limitations of this section which, at the sole discretion of the Executive Director, may be granted or denied. Any decision made by the Executive Director must be in writing. Any decision of the Executive Director may be appealed to the Area Board of Zoning Appeals.

10.12.10 Incidental Signage, Other

Each property used for commercial, industrial, institutional or government purposes is entitled to an accumulation of incidental signage up to sixty (60) square feet of sign face as long as no individual sign exceeds sixteen (16) square feet of sign area. All incidental signage covered under this subsection may be placed up to the property line or right-of-way line, whichever is most restrictive, as long as it does not infringe into the vision clearance triangle as provided for in Section 3.0.7 of this Ordinance or create what, in the sole opinion of the Executive Director, is a safety hazard or nuisance. Any decision of the Executive Director may be appealed to the Area Board of Zoning Appeals. In the case of a facility which includes refueling pumps or recharging stations, the signage included on or attached to the pumps or recharging stations is allowed in addition to the incidental signage provided for above or any other sign limitations provided in the Chapter.

10.12.11 Yard signs – on premise

- A. Shall not exceed six (6) square feet in sign area and five (5) feet in sign height;
- B. Must be separated by no less than twenty (20) feet; and,
- C. Shall be located in a reasonable and safe manner as determined by the Executive Director.

10.12.12 Disposable signs – on premise

- A. Shall not exceed four (4) square feet in sign area and three (3) feet in sign height;
- B. May not be located in a right-of-way;
- C. Shall not be located closer than twenty (20) feet to any other on-premise, disposable sign; and,
- D. Shall be located in a reasonable and safe manner as determined by the Executive Director.

10.12.13 Suspended Signs

Signs suspended above a walkway or road/street right-of-way shall be allowed, provided such signs meet the following criteria:

- A. No suspended sign face shall exceed twelve (12) square feet in sign area;
- B. No part of a suspended sign shall extend closer than eight (8) feet above the area over which it is suspended;
- C. Only one (1) suspended sign per building entrance shall be allowed; and,
- D. Suspended signs may extend above a right-of-way without requiring authorization from the respective legislative body.

10.12.14 Window signs and signs viewable through a window

All windows shall be allowed to contain signs or advertising information as long as the signs or information are mounted on the glass pane only; regardless of whether or not mounted from the inside or the outside of the window.

Any interior signage or promotional displays visible from the outside through a window are exempt.

All window signs or signs viewable from a window must meet the illumination standards of Section 10.4 of this Chapter.

10.12.15 A-frame and T-frame signs

A-frame or T-frame supported signs are allowed. A-frame or T-frame signs may be placed on a sidewalk provided that such placement is in a reasonable manner and, in the sole opinion of the Executive Director, does not create an unsafe condition for pedestrians or vehicular travel. Off premise A-frame and T-frame signs are not allowed unless authorized by variance from the Area Board of Zoning Appeals. For purposes of this Subsection, an A-frame or T-frame sign placed on a sidewalk in a right-of-way is not considered an off-premise sign if the section of right-of-way in which the sign is located abuts the sign owners property.

10.12.16 Decorative Signs (Banners, lights, balloons, pennants and streamers)

Decorative signs are allowed as long as they are kept in good repair and in a neat, clean and attractive condition and do not create a general nuisance for the public or a near-by property owner. Failure to maintain such signs or utilizing such signs in a way that creates a nuisance may be removed or caused to be removed at the discretion of the Executive Director and will be at the expense of the sign and/or property owner. Property owners and/or sign owners can be assessed a fine for failure to remove a sign upon written notification from the Staff. All such signs must be positioned in a manner which does not create a safety hazard, nuisance or motorist distraction nor shall they interfere with pedestrian or vehicular circulation. Decorative signs are limited to sixty (60) consecutive days at a time. Each parcel, lot or tract of land is limited to no more than two (2) Decorative signs at a time and limited to two (2) such usages in any twelve (12) month period unless authorized in writing by the Executive Director. Any Decorative sign utilized for sixty-one (61) days or more in any twelve month rolling period requires a sign permit. Decorative signs must not infringe on the the vision clearance triangle as provided for in Section 3.0.7 of this Ordinance, or create what is, in the sole opinion of the Executive Director, a safety hazard or nuisance. The standards and limitations of this subsection may be modified upon written authorization of the Executive Director or with variance approval from the Area Board of Zoning Appeals.

10.12.17 Community service central displays/Community Adoption Signs

Identification signs incorporated in central displays of community service shall be allowed provided each sign:

- 1) meets the developmental standards for the sign type used;
- 2) the signage is authorized in writing by the property owner;

- 3) complies with the visual clearance triangle regulations found in Section 3.0.7 of this Ordinance ; and,
- 4) is set back at least ten (10) feet from the road right-of-way or property line, whichever is most restrictive.

Such signs are limited to non-profit organizations only. Such signs shall contain no entity promotional attributes or create what is, in the sole opinion of the Executive Director, a safety hazard or nuisance.

Signs placed to note a person or entities responsibility for maintenance of a public right-of-way area, such as “adopt a highway”, or financial support for landscaping and/or cleanliness of a road area shall be allowed provided each sign is:

- 5) Authorized in writing by the property owner;
- 6) no closer than one (1) foot to any road travel surface and/or shoulder;
- 7) meets the developmental standards for the sign type used;
- 8) complies with the visual clearance triangle regulations found in Section 3.0.7 of this Ordinance;
- 9) contains no entity promotional attributes other than an entity or companies name and/or logo; or,
- 10) create what is, in the sole opinion of the Executive Director, a safety hazard or nuisance.

10.12.18 Bench signs

Bench signs are allowed provided they do not create a safety hazard, as determined by the Executive Director. There is no setback requirement for a bench sign but they may not violate the vision clearance triangle standards, nor impede an ADA routing requirement or allowance. Any bench sign intended for placement in a right-of-way, must have written approval from the regulating legislative body.

10.12.19 Changeable Copy Signs, Portable

Portable, changeable copy signs are exempt if utilized for sixty (60) days or less; otherwise, they require a sign permit. Portable changeable copy signs must meet the standards for ground signs but are not counted toward a properties ground sign count allowance. These signs may not utilize either exterior or interior lighting; nor may they be placed within a vision clearance triangle area or be placed in a manner which, at the sole discretion of the Executive Director, create a safety hazard or nuisance. This subsection does not apply to portable, Changeable Copy signs utilized by a department of a governmental body.

10.12.20 Neighborhood watch and similar community awareness signs

- A. Are allowed on utility poles or road sign structures, excluding stop signs, as long as permission from the respective agency has been acquired. . Such signs are otherwise allowable subject to the regulations as required by the sign type;

- B. Shall be located in a reasonable and safe manner as determined by the Executive Director; and,
- C. Shall not exceed two (2) square feet in sign area.

10.12.21 Barn Quilt Signs

Barn Quilt signs are visual replicas of quilt, quilt patterns or quilt sections which are painted on a substrate for the viewing pleasure of the general public with no intended or actual economic benefit for any enterprise, organization or entity. All Barn Quilt Signs shall meet the following standards:

- A. There may be multiple Barn Quilt (BQ) Signs per Barn or Barn Crib with a maximum of 200 square foot of signage face per Barn side;
- B. An individual BQ Signs shall not exceed a face size of 8' square;
- C. All BQ Signs shall be surface mounted to a barn subject to Wall Sign Standards;
- D. All BQ Signs shall display a quilt pattern only (no verbiage);
- E. All BQ Signs shall be painted on an aluminum or wood based substrate (or equivalent);
- F. A BQ Signs shall be repaired when paint chipping, surface fading or any other effect to the sign creates a significant discontinuity or negative impact to the image;
- G. All BQ Signs shall be positioned to be completely visible from the road rights-of-way; and,
- H. BQ Signs may be mounted to a structure other than a barn or barn crib with written permission for the Area Plan Executive Director.

10.12.22 Water Tower Signs

Signs placed on any surface of a water tower tank which identify a municipality, utility, location, industrial park or other information. Those which advertise the name, products, services or other aspects of an industrial or commercial enterprise are not exempt from the permit requirements of this Chapter and shall be subject to the standards of a wall sign.

10.12.23 Retail Signage

On-premise signs on a property used for retail purposes which satisfy the following standards are exempt:

- A. The sign face is less than two (2) square feet;
- B. The sign does not utilize electronic features of any kind, whether interior or exterior;
- C. The sign is not located within a rights-of-ways;
- D. The sign does not impair visibility or distract drivers of motor vehicles;and,
- E. The sign does not interfere or disrupt any pedestrian or motor vehicle circulation route.

10.12.24 Natural Composite Signs

Information placed on or incorporated into the face of a natural substrate, such as, but not limited to, a stone, rock, marble or wood, are limited to use only to identify a street address or family name. They may not be placed in a right-of-way or in any manner, which in the sole opinion of the Executive Director, shall create a safety or nuisance to the community.

10.12.25 Vehicle Signs

Signs on vehicles or trailers of any type, upon which someone has painted, inscribed, written or mounted a sign unless the vehicle or trailer is inoperable, unregistered or stationary for a period of ten (10) business days or more, then a sign permit must be obtained.

10.12.26 Murals, Wall Graphics And Works Of Art

Murals, Wall Graphics and Works of Art with no commercial message or intent and which contain no name of any entity except the community, creator or those historically related to the mural, wall graphic or work of art.

Murals, Wall Graphics and Works of Art must comply with the standards, restrictions and regulations for the particular sign type. In cases of Works of Art, they shall be subject to accessory structure developmental standards.

10.12.27 Public Signs

Public signs erected by or on the order of a public official in the performance of a public duty, such as signs to promote safety, no trespassing, no skate boarding or vehicle/pedestrian routing management or similar such sign.

10.12.28 Utility Marker Signs

Signs for the purpose of marking utility cables and/or lines for public or private utilities or to provide safety or hazard notice. These signs must be located in a manner which, in the sole opinion of the Executive Director, does not create a safety hazard.

10.12.29 Park or athletic field fence signage, wall signage and scoreboard signage, subject to the standards listed below:

- A. Fence signage must not extend more than three (3) inches beyond the fence perimeter;
- B. All fence signage must have written authorization from the property owner;
- C. Any illuminated or electronic messaging sign must meet all standards for such signage as provide for in this Ordinance.

10.13 TEMPORARY SIGNS

Temporary signs do not require a permit. Temporary signs may be allowed at any non-residential location within the County, in accordance with the provisions of this Chapter. For residential districts, all signs must comply with Section 10.7 of this chapter. Temporary signs may not be placed to infringe the provisions of a visual clearance triangle as provided for in Chapter 3, Subsection 3.0.7, nor be placed in a manner, which, at the sole discretion of the Executive Director, creates a safety hazard or nuisance. Temporary signs are not allowed in a road or street rights-of-

way and must meet the regulations, development standards and setbacks for the particular sign type used.

Temporary signs used in conjunction with a temporary use permit shall be allowed for the duration of time the temporary use permit is valid.

In addition, all temporary signs must satisfy the following:

- A. Be located in a reasonable and safe manner as determined by the Executive Director;
- B. Be displayed for a period not to exceed twelve (12) months or as provided elsewhere in this Section. The twelve (12) months may be extended by a period not to exceed six (6) months if the extension is approved in writing by the Executive Director or his/her appointee. The display time limitations apply to any thirty-six (36) consecutive month rolling period;
- C. Be no greater than eight (8) feet in sign height;
- D. Be located in such a way that they do not obstruct the flow or sight pattern of vehicular or pedestrian traffic traveling on any established road/street right-of-way;
- E. Be at least twenty (20) feet from any adjacent residential district;
- F. Shall not exceed thirty-two (32) square feet in sign area;
- G. Be free of blinking lights;
- H. In compliance with all electrical installation building codes;
- I. Be in compliance with all other applicable regulations of this Chapter.

CHAPTER 11

ADMINISTRATIVE BODIES AND OFFICIALS

11.0 SUMMARY OF AUTHORITY

The county and municipal bodies and officials listed in this Chapter, without limitation upon such authority as each may possess by law, have responsibility for implementing and administering this Ordinance in the manner described herein.

11.1 BODIES AND OFFICIALS

11.1.1 County Commissioners

The County Commissioners hereby reserves to itself the following powers and duties in connection with the implementation of this Ordinance for the unincorporated areas of White County:

- A. To initiate amendments to this Ordinance and to adopt, reject, or amend proposals to amend or partially repeal the text of the Ordinance.
- B. To adopt, reject, or amend proposals to amend the zoning map pursuant to the procedures and standards for amendments set forth in Chapter 12, Administration.
- C. To adopt, reject, or amend a Planned Unit Development pursuant to the procedures and standards for amendments set forth in Chapter 12, Administration.
- D. To take such other actions not delegated to other bodies, which may be desirable and necessary to implement the provisions of this Ordinance.

11.1.2 Municipal legislative bodies

The legislative body of each of the participating municipalities hereby reserves to itself the following powers and duties in connection with the implementation of this Ordinance for the area within its jurisdiction:

- A. To initiate amendments to this Ordinance and to adopt, reject, or amend proposals to amend or partially repeal the text of this Ordinance.
- B. To adopt, reject, or amend proposals to amend the zoning map pursuant to the procedures and standards for amendments set forth in Chapter 12, Administration.
- C. To adopt, reject, or amend a Planned Unit Development pursuant to the procedures and standards for amendments set forth in Chapter 12, Administration.
- D. To take such other actions not delegated to other bodies which may be desirable and necessary to implement the provisions of this Ordinance.

11.1.3 Area Plan Commission

A. Establishment

There is established the Area Plan Commission, to be known as the White County Area Plan Commission. The Area Plan Commission shall be a continuation of the present Area Plan Commission established under plan law, IC 36-7-4-200 Series: Commission Establishment and Membership, as amended from time to time.

B. Composition

The Area Plan Commission shall consist of membership as authorized by IC 36-7-4-211 as amended from time to time and shall be prescribed as follows:

1. Two (2) representatives from each city having a population of less than ten thousand (10,000)
 - a. One (1) member appointed by the municipality legislative body from its membership
 - b. One citizen member appointed by the municipal executive
2. One (1) representative from each town having a population of two thousand one hundred (2,100) or less that had a representative before January 1, 1979
3. Such representatives from towns having a population of not more than two thousand one hundred (2,100) as are provided for in IC 36-7-4-210 as amended from time to time
4. One (1) member appointed by the county executive from its membership or the county executive's designee
5. One (1) member appointed by the county fiscal body from its membership
6. One (1) representative appointed by the school corporation superintendents within the jurisdiction of the Area Plan Commission
7. One (1) of the following appointed by the County Executive:
 - a. The county agricultural extension educator
 - b. The county surveyor or the county surveyor's designee
8. One (1) citizen member appointed by the County Executive who is:
 - a. A resident of the unincorporated area of the county; or
 - b. A resident of the county who is also an owner of real property located in whole or in part in the unincorporated area of the county
9. One (1) citizen member appointed by the county fiscal body who is:
 - a. A resident of the unincorporated area of the county; or
 - b. A resident of the county who is also and owner of real property located in whole or in part in the unincorporated area of the county

C. Terms of office

1. Each citizen member shall be appointed for a four (4) year term expiring on the first Monday of January of the fourth year after the year of the member's appointment.

2. Advisory council members shall be elected for one (1) year terms, terminating at the end of the year.
3. Any member who is appointed from the membership of a legislative body or a park board is coextensive with the member's term of office on that body, board, or council, unless the body, board, or council appoints, at its first regular meeting in any year, another to serve as its representative.
4. All other members shall serve a four (4) year term expiring on the first Monday of January of the fourth year after the year of the member's appointment.

D. Conflict of interest

Pursuant to IC 36-7-4-223, no member of the Area Plan Commission or appropriate legislative body may participate in a hearing or decision of that Commission or body concerning a zoning matter in which he or she has a direct or indirect financial interest. The Commission or body shall enter in its records the fact that its member has a disqualification.

E. Territorial jurisdiction

The Area Plan Commission shall have jurisdiction over all the land subject to this Ordinance.

F. Duties

For the purpose of this Chapter, the Area Plan Commission shall have the following duties:

1. Initiate and review all proposed amendments to the text of this Ordinance and the Zoning Map pursuant to the procedures and standards set forth in Chapter 12, Administration.
2. Review and make Findings of Fact on subdivision plats, site development plans, planned unit developments, and other similar plans for proposed land developments within the Commission's jurisdiction.
3. Initiate, perform, administer and enforce the Comprehensive Plan, Zoning Ordinance, and Subdivision Control Ordinance.
4. To initiate amendments to the White County Subdivision Control Ordinance and to adopt, reject, or amend proposals to amend or partially repeal the text of this White County Subdivision Control Ordinance.
5. To approve, approve with modifications, or deny all applications for waivers from the Subdivision Control Ordinance pursuant to the procedures and standards for plat approval set forth in the Subdivision Control Ordinance.
6. To supervise and adopt rules for the administration of the affairs of the Area Plan Commission.
7. Record and file all bonds and contracts and assume responsibility for the custody and preservation of all papers and documents of the Area Plan Commission.

8. To prepare, publish, and distribute reports, ordinances, and other material related to the Area Plan Commission activities as authorized by this Ordinance or any other applicable law.
9. To invoke any legal, equitable, or special remedy available by law or this Ordinance for the enforcement of the provisions of this Ordinance or actions taken there under.
10. To exercise all powers conferred on it by law, local ordinance or rule in the manner so prescribed. This Section shall not be construed as a limitation on such powers.

G. Staff

The staff of the Area Plan Commission shall consist of the Executive Director, as defined in Chapter 14, Definitions, and any other persons employed or otherwise hired by the Area Plan Commission from time to time to assist the Executive Director or the Area Plan Commission.

H. Rules and procedures

The following rules and procedures shall apply:

1. The Area Plan Commission shall have sole authority to adopt any and all rules under IC 36-7-4-401 and any and all procedures concerning organization, selection of officers, forms for applications, filing requirements, other than as to place of filing as herein provided for, procedures, notices for and conduct of meetings and public hearings
2. Facilities and funding

The County shall provide suitable facilities and security for the holding of Area Plan Commission meetings and hearings and the storage of its records, documents, and accounts, and in its annual budget to provide sufficient funds for the functioning of the Commission and its staff

3. Prescribed filing forms

All applications for subdivision plats, site development plans, Zoning Ordinance amendments, improvement location permits, or other petitions coming before the Commission or its staff shall be filed in the form and quantities prescribed by the Commission.

11.1.4 Board of Zoning Appeals

A. Establishment

The Board of Zoning Appeals is hereby established under the planning law, being IC 36-7-4-900, as added by Acts 1981, Pub. L. 309 Sec. 23., and is to be known as the White County Board of Zoning Appeals and shall be a continuation of the present Board of Zoning Appeals.

B. Composition

The Board of Zoning Appeals shall consist of the following five (5) members.

1. One (1) citizen member appointed by the Area Plan Commission, from its membership.
2. One (1) citizen member appointed by the Mayor of Monticello provided said citizen member is not a member of any Plan Commission.
3. Two (2) citizen members, one who must be a member of the Plan Commission and one who is not a member of any Plan Commission, appointed by the County Commissioners.
4. One (1) citizen member, who may not be a member of any plan commission, appointed by the executive of the second largest municipality in the county participating in the commission.

C. Terms of office

Following adoption of this Ordinance, each member of the BZA shall be reappointed for the balance of the term being served on the present Board of Zoning Appeals. Thereafter, each member shall be for a term of four (4) years. Each term shall expire on the first Monday of January of the fourth year of the four-year (4-yr.) term. Following the term expiration, a member shall be considered a temporary appointee until such time as a replacement is named or the member is reappointed. All votes taken during the interim appointment shall reflect the status of the temporary appointee.

1. The member selected by the Area Plan Commission shall hold office for a term of four (4) years.
2. The member appointed by the Monon Town Council shall serve for a term of three (3) years.
3. One member appointed by the County Commissioners shall hold office for a term of three (3) years and the other shall hold office for a term of two (2) years.
4. The member appointed by the Mayor of Monticello shall serve for a period of two (2) years.

D. Conflict of interest

Pursuant to IC 36-7-4-909, a member of the Board of Zoning Appeals may not participate in a hearing or decision of that Board concerning a zoning matter in which he or she has a direct or indirect financial interest. The Board shall enter in its records the fact that its member has such a disqualification.

E. Jurisdiction

1. Territorial jurisdiction

The Board of Zoning Appeals shall have jurisdiction over all the land subject to the Zoning Ordinance.

2. Subject matter jurisdiction

The Board of Zoning Appeals shall have exclusive subject matter jurisdiction for the following

- a. Development standards variance

- b. Special exception uses
- c. Administrative appeals

F. Staff

The staff of the Board of Zoning Appeals shall consist of the Executive Director as defined in this Ordinance, and other persons employed or otherwise hired by the Board of Zoning Appeals to assist the Executive Director.

G. Rules and Procedures

1. Rules and procedures

The Board of Zoning Appeals shall have sole authority to adopt any and all rules under IC 36-7-4-916 and any and all procedures concerning organization, selection of officers, forms for applications, filing requirements, other than as to place of filing as herein provided for, procedures, notices for and conduct of meetings and public hearings.

2. Facilities and funding

The County shall provide suitable facilities for the holding and security of Board of Zoning Appeals meetings and hearings and the storage of its records, documents, and accounts, and in its annual budget to provide sufficient funds for the functioning of the Board and its staff

3. Filing

All applications for variances, special exception uses, and requests for appeal shall be filed by the applicant with the staff of the Board of Zoning Appeals and in the form prescribed by the Board.

H. Prescribed filing forms

All applications for special exception uses, variances, or appeals or other petitions coming before the Board of Zoning Appeals or its staff shall be filed in the form and quantities prescribed by the Board.

11.1.5 Technical Review Committee

The Area Plan Commission shall establish a Technical Review Committee for the purpose of providing detailed reviews and recommendations to the Area Plan Commission concerning proposed development plans or subdivision plats as prescribed in the White County Indiana Zoning Control Ordinance or as prescribed in the White County Indiana Subdivision Control Ordinance as amended from time to time.

A. Composition

Membership of the Technical Review Committee will consist of five (5) members and assigned as follows:

- 1) The Area Plan Executive Director or his/her designee; appointing authority, Area Plan Executive Director;
- 2) The County Surveyor or his/her designee; appointing authority, County Surveyor;

- 3) Three members of the Area Plan Commission, other than the Surveyor; appointing authority, Area Plan Commission.

Ex Officio members of the Technical Review Committee consist of the following:

- 1) County Health Department; Health Department
- 2) County Surveyor;
- 3) A representative and/or designee of the County Soil and Water Conservation District;
- 4) County Highway Engineer and/or Superintendent from the appropriate jurisdiction;
- 5) Wastewater Superintendent from the appropriate jurisdiction;
- 6) Water Superintendent from the appropriate jurisdiction;
- 7) A Fire District Representative from the appropriate jurisdiction;
- 8) Building Department;
- 9) Clerk-Treasurer of the body with jurisdictional authority over the geographic area in which the development is proposed; in the case of an area in the unincorporated area of the County, the County Executive; and
- 10) Any other persons deemed appropriate by the Executive Director.

B. Duties

The Technical Review Committee shall limit its attention and recommendations to the design and construction aspects of the proposed development or subdivision with emphasis placed on public improvements, utilities, drainage, landscaping, parking, and other development standards. Projects shall be reviewed for compliance with the Zoning Ordinance and compatibility with the Comprehensive Plan, including, when applicable, the aspects of design within an adopted Historic Preservation District.

1. The purpose of the Technical Review Committee is to provide written recommendations pertaining to technical aspects of the design and construction plans; approval or disapproval of a development or subdivision is clearly the responsibility of the Area Plan Commission
2. The Technical Review Committee shall have the authority to request that a docket be continued by the Area Plan Commission until the Committee has reviewed revised plans submitted by the petitioner(s).

C. Coordination between zoning and subdivision ordinances

The Committee is established under both the Zoning Ordinance and the Subdivision Control Ordinance to serve the differing needs of these two (2) ordinances. The Committee shall be made up of the same members under both ordinances in order to facilitate coordination of the decision-making by the Area Plan Commission with respect to the design and construction aspects of these two (2) ordinances.

D. Committee meetings

Because the Technical Review Committee is strictly a committee and does not have the authority to take any official action, the Committee shall not be bound to holding

public meetings. The Committee shall meet as necessary. After each meeting, the Committee shall then submit its review comments and recommendations in writing to the Area Plan Commission.

Notification of Tech Committee meetings shall go to all Tech Committee members and to all Ex Officio members determined by the Executive Director to be pertinent to the submitted application.

11.1.6 Hearing Examiner

The Area Plan Commission may delegate to a Hearing Examiner the authority to conduct any public hearing required to be held by the Commission or make any decision required to be made by the Commission, or both, excluding any authority or decisions provided for in the Subdivision Control Ordinance or the 700 Series, Subdivision Control of State Statute IC 36-7-4.

Such hearings must be held upon the same notice and under the same rules as a hearing before the entire Commission, including providing a Written Findings of Fact and Decision, as is required by law for the Commission.

A decision made under the authority of this subsection may not be a basis for judicial review, but may be appealed to the Area Plan Commission. Any interested party who wishes to appeal a decision made by the Hearing Examiner, must file the appeal not later than five (5) days after the date of the decision. The Area Plan Commission will then hold the prescribed hearing and render its decision.

11.1.7 Hearing Officer

The Area Plan Commission, by its Rules and Procedures, or if provided for by Ordinance, may authorize a Hearing Officer to conduct hearings to disposition certain matters under an Alternate Procedure established in Chapter 12, Section 12.15 of this Ordinance.

11.1.8 Plat Committee

The Area Plan Commission shall establish a Plat Review Committee for the purpose of reviewing and approving/denying subdivision plats and replats when prescribed for in the White County Indiana Subdivision Control Ordinance.

A. Composition

The Plat Committee shall consist of five (5) members appointed by the Area Plan Commission. Membership of the Plat Committee must include at least one member from the Area Plan Commission; (reference IC 36-7-4-701 (e)). Representatives of the Tech Review Committee may attend as Ex Officio members of the Plat Committee.

B. Term

Each member of the Plat Committee will have a term of one (1) year which will begin January 1 and end December 31 of each respective year. The terms shall automatically renew for consecutive one (1) year terms until such time as:

- 1) The member resigns; or,
- 2) The member is terminated by the Area Plan Commission.

C. Duties

Review and approval/denial of subdivision plats and replats when prescribed for in the White County Indiana Subdivision Control Ordinance

D. Powers/Authority

Plat Committee shall have all the powers of the Plan Commission as they pertain to subdivision plats

E. Committee meetings

The Plat Committee shall each year, prior to the first day of December, establish a meeting calendar for the following year. The Committee calendar shall consist of at least eight (8) scheduled meetings for each calendar year. Due to the nature of the hearings slated for Plat Committee review, the Plat Committee meetings are not required to be heard in a public venue nor are they required to give public notice of their meetings. However, within ten (10) days after the Plat Committee gives primary approval of a subdivision plat, the Staff shall provide written notice to interested parties of their right to appeal a decision of the Plat Committee to the Area Plan Commission. (Reference IC 36-7-4-701 (d))

Any party wishing to file an appeal of a Plat Committee decision must file the appeal with the Staff not more than five (5) days after a copy of the Plat Committees action is mailed to the interested party

F. Official action

The Plat Committee may take action only by a majority (quorum) vote. (Reference IC 36-7-4-701 (e))

CHAPTER 12 ADMINISTRATION

12.0 APPLICATION AND PERMIT TYPES

12.0.1 Petition applications required

An application shall be submitted for each of the following types of petitions:

- A. Development Standard Variance
- B. Special Exception Use
- C. Appeal of an Administrative Decision
- D. Zoning Map Amendment (Rezoning)
- E. Interpretations of the White County Zoning Ordinance
- F. An Improvement Location Permit in accordance with this Chapter, including sign permits (see also Chapter 10, Sign Standards, for additional application and permit provisions).
- G. Planned Unit Development, as prescribed by Chapter 5, Planned Unit Development

12.0.2 Applications, general

A. Location

All applications shall be made on forms provided by the Office of the Area Plan Commission. All applicants shall submit original application form(s), completed in its/their entirety. All applications shall be accompanied with their associated fee(s), and all other required documents as prescribed by this Ordinance.

B. Determination of a Complete Application

No application shall be considered complete until (a) the petitioner has provided a completed application form, (b) the application form is filed in the number of duplicate copies as directed by the Executive Director, (c) the form contains all owner and applicant signatures, and (d) the required fee or fees have been paid.

C. Drawing form, scale and size

All drawings shall be at a scale not smaller than one inch equals fifty feet (1" = 50") with a scale of one inch equals thirty feet (1" = 30') being preferred. Any other scale must be approved by the Executive Director. No individual sheet or drawing shall exceed twenty-four inches by thirty-six inches (24" x 36"). In addition, one (1) set of reduced copies sized at eleven inches by seventeen inches (11" x 17") shall be submitted. All sets of drawings submitted must be folded and collated.

D. Filing Deadlines and Meeting Schedule

1. Applications requiring a public hearing or meeting

An application requiring a public hearing or meeting will not be scheduled for such hearing or meeting unless filed in proper form and number and containing all required information. All public hearings and meetings to consider applications filed pursuant to the White County Zoning Ordinance shall be scheduled at the same time as the regular meetings of such body, unless otherwise provided by order of the appropriate body. A public hearing for an application so filed will be scheduled pursuant to the Calendar of Meetings and Filings Dates published by the relevant body each year.

2. Applications not requiring a public hearing

An application that does not require a public hearing shall be filed in proper form and number and contain all required information. An application so filed will be processed on a first-filed, first processed basis.

3. Supplemental data for previously filed applications

Whenever supplemental data in connection with a previously filed application is required by the County, appropriate legislative body or offered by the applicant, it shall be submitted no later than the revised submittal deadline published in the Calendar of Meeting and Filing Deadlines and shall be considered at a hearing or a meeting or acted upon in connection with such application. The filing of such data may, at the discretion of the Executive Director and/or the body entertaining the application, be cause to delay a requested or scheduled hearing or decision date.

E. Additional information required

Every applicant shall submit such other data, information, or documentation as the Executive Director, the Area Plan Commission, the Area Board of Zoning Appeals or any appropriate legislative body before which its application is pending may deem necessary or appropriate to achieve a full and proper consideration and disposition of the particular application. The Area Plan Commission further reserves the right to require an impact statement explaining the impacts of a project on the County. This includes the use of an interpreter when necessary.

12.1 OFFICIAL FEE SCHEDULE

A separate ordinance, as amended from time to time, shall establish a schedule of fees, charges, and expenses and a collection procedure for zoning permits, sign permits, certificates of zoning compliance, special exception use permits, development standards variances, appeals, applications to amend this ordinance, rezonings, and other matters pertaining to this Ordinance or the operation of the Area Plan Department.

12.1.1 Maintenance

The Area Plan Staff shall maintain the Official Fee Schedule, charges, and expenses, as set forth periodically by the County Commissioners, and also a collection procedure for permits, appeals, and other petitions pertaining to the White County Zoning Ordinance and the White County Subdivision Control Ordinance.

12.1.2 Availability

The Official Fee Schedule shall be available to the public in the office of the Area Plan Commission and may be altered or amended only by ordinance of the County Commissioners.

12.1.3 Responsibility of payment

The owner of the property which is the subject of an application shall be liable for the payment of the fee. In the event that the applicant is different than the owner, the owner and the applicant shall be jointly and severally liable for the payment of the fee.

12.1.4 Payment in full

All applicable fees, charges, and expenses shall be paid in full by the applicant or owner, at the time of application. Failure to fully pay any such fee or required deposit at application shall be grounds for refusing to process an application and for denying or revoking any permit or approval sought or issued with respect to the land or development to which the unpaid fee or required deposit relates. Only the Area Plan Commission, Area Board of Zoning Appeals, and/or the County Commissioners have the ability to waive fees prescribed by the Official Fee Schedule.

12.1.5 Contracting of independent professionals

Payment to defray the costs of contracting with independent professionals to provide services required for consideration of an Area Plan Department matter shall be set by the County Commissioners. Such professional costs may include, but are not limited to: planning, engineering, legal, traffic analyses, environmental impact or other similar studies; development plan review; or inspections.

12.2 PUBLIC HEARINGS AND MEETINGS

12.2.1 Setting a hearing or meeting

When the provisions of this Ordinance require a public hearing or public meeting in connection with any application filed pursuant to this Ordinance, it shall be heard in accordance with the published schedule of the official or body charged with conducting the hearing or meeting.

A. Time of meeting

The exact time for hearings or meetings held before the Board of Zoning Appeals or Area Plan Commission, as the case may be, shall be determined by the official filing deadline adopted annually. Applications shall be filed in the Office of the Area Plan Commission no later than the deadline published in the Calendar of Filing and Meeting Dates.

B. Notice to adjoining property owners

For all public hearings, the notice shall be provided to the public consistent with the requirements of this Chapter and the requirements of IC 5-3-1 as amended. A public notice required by this Ordinance shall meet the following requirements:

1. Preparation

The Staff shall prepare and provide a legal notice consistent with the requirements of IC 5-3-1 and the applicable Area Plan Commission, Board of Zoning Appeals, and/or appropriate legislative body's Rules of Procedure.

2. Content of public notice

In addition to stating the name of the applicant, the notice shall state the physical address of the subject property. In the event that the subject property does not have a physical address, a general description shall be given. The content of the notice shall also state the date, time and location of the hearing and the name of the presiding Board (White County Area Plan Commission/Area Board of Zoning Appeals/Hearing Officer/Hearing Examiner). The notice shall also include a legal description of the subject property.

3. Distribution

Staff of the Area Plan Commission Office shall distribute, by first class mail, written notice of the application to all interested parties in accordance with IC 5-3-1 as amended.

4. Certificate of issuance

Prior to the public hearing a certificate of issuance shall be prepared by the Staff of the Area Plan Commission Office and include such certification in the file of record to which it applies.

C. Newspaper notice

The Staff shall arrange for the publication of a public notice to be placed in a newspaper of general circulation in the jurisdictional area. Said notice shall include the same information as described in the notice to adjoining property owners subsection 12.21(B), Notice to adjoining property owners. The notice shall run at least one (1) time in the paper at least ten (10) days before the date of the meeting or hearing, in accordance with IC 5-3-1 as amended.

12.2.2 Review of Application Materials

All materials related to any application for which the White County Zoning Ordinance requires a hearing shall first be reviewed by the Staff to determine if the application is complete. The Staff shall also refer the application to other County bodies or officials for their comments as necessary. Each body and official to which an application is referred shall review such application and submit its comments thereon to the Staff for transmittal to the specific body or Official hearing the application.

12.2.3 Conduct of hearings

All other matters pertaining to the conduct of hearings shall be governed by the provisions of the White County Zoning Ordinance pertaining to, and the rules promulgated by, the official or body conducting the hearing.

12.2.4 Examination and copying of application and other documents

At any time following the giving of notice as required per IC 5-3-1-2 et seq. in this Chapter and upon reasonable request, any person may examine the application and, subject to the exceptions set forth in the Indiana Freedom of Information Act, all other

documents on file pertaining to the application. In addition, any person shall be entitled to copies of such application and documents upon reasonable request and payment of a fee prescribed by the Staff to cover the cost of such copies.

12.3 SUCCESSIVE APPLICATIONS (PETITIONS), APPEALS

12.3.1 Second applications barred without new grounds

Whenever any application (petition) or appeal filed pursuant to the White County Zoning Ordinance has been denied, a second application seeking essentially the same relief, whether or not in the same form or on the same theory shall not be brought before the County for one (1) year unless in a majority vote of the board or commission before which it is brought determines to reconsider the vote because there is substantially new evidence available, or a mistake of law or fact significantly affected the prior denial.

12.3.2 New grounds to be stated

A second application submitted on new grounds may be brought before the County in the same manner as a new application for the type of request made. Any such second application shall include a detailed statement of the grounds justifying a second consideration of such application, and place in the record all evidence available concerning changes of conditions or new facts that have developed since the denial of the first application.

12.3.3 Summary denial with or without hearing

Any such second application may be denied by the Executive Director summarily, and without hearing, on a finding that no grounds appear that warrants a new hearing. In any case where such application is set for a hearing, the applicant shall be required to establish grounds warranting reconsideration of the merits of the application prior to being allowed to offer any evidence. Unless such grounds are established, the application may be summarily dismissed for such failure.

12.3.4 Exception

Whether or not new grounds are stated, any such second application filed more than one (1) year after the denial of a prior application shall be heard on the merits as though no prior application had been filed. The applicant shall, however, be required to place in the record all evidence available concerning changes of conditions or new facts that have developed since the denial of the first application. In the absence of such evidence, it shall be presumed that no new facts exist to support the new petition that did not exist at the time of the denial of the first application.

12.4 DEVELOPMENT STANDARDS VARIANCE

A Development Standards Variance is designed to adjust the regulations (such as bulk, height, area, etc) of the White County Zoning Ordinance to the land for which the variance is granted. The primary basis for granting a development standard variance is the showing by the applicant that a practical difficulty exists if the letter of the law is strictly applied. In no case shall any variance to the terms of the White County Zoning Ordinance be authorized without the approval of the Area Board of Zoning Appeals (BZA) or the Area Plan Hearing Officer. All applications for a Development Standards

Variance will be heard utilizing the following procedures or, where applicable, the Alternate Procedure outlined in Section 12.16.

12.4.1 Authority

The Area Board of Zoning Appeals may upon petition authorize the granting of a variance from the development standards (such as height, bulk, or area) of the White County Zoning Ordinance, pursuant to IC 35-7-4-918.5 as amended. Additionally, the Area Board of Zoning Appeals may authorize the granting of a variance for a parcel in a recorded subdivision but only in those cases where the County Zoning Ordinance developmental standards are applied.

12.4.2 Burden of proof

The burden of demonstrating a need for the development standard variance falls upon the applicant seeking the variance. The burden of demonstrating that the terms of a development standard variance granted by the Area Board of Zoning Appeals have been met rests on the applicant granted the variance.

12.4.3 Application

The applicant shall submit a completed development standard variance application, the required filing fee, and required supporting information to the Executive Director. Supporting information shall include, but shall not be limited to, the following:

A. Dimensional Survey

The applicant shall obtain a dimensional survey of the subject property, prepared by a registered land surveyor, showing the property lines, distances from the property lines to the improvements and any structures on adjacent properties within 50' of the subject property's property lines, easements, existing and proposed structures complete with dimensions, parking, wells, grinders, and septic systems. Any costs associated in the completion of said survey shall be the responsibility of the applicant. The survey requirement may be waived or modified by the Executive Director in cases where he/she determines a scaled down survey or site plan will suffice.

B. Site Plan

A site plan as prescribed by this Chapter.

C. Written Commitments (if applicable)

Documentation of any written commitments as prescribed by this Chapter

12.4.4 Notification

Notification of public hearing as prescribed by this Chapter.

12.4.5 Action by Executive Director

Upon receipt of a properly completed application for variance, the Executive Director shall transmit the application to the Area Board of Zoning Appeals together with all the other administrative reports and recommendations regarding the proposed application.

The application shall be scheduled for a public hearing in accordance with the requirements of this Chapter.

12.4.6 Public hearing

The Area Board of Zoning Appeals shall, in a public hearing scheduled consistent with the adopted Calendar of Meetings and Filings Dates, review the variance application and required supporting information. The presentation of reports and testimony and all other aspects of the public hearing shall be consistent with the By-Laws of the Board.

12.4.7 Decision criteria prescribed by state law

In taking action on all development standard variance requests, the Area Board of Zoning Appeals shall use the following decision criteria, which are consistent with the requirements of Indiana Code.

A. General welfare

The approval will not be injurious to the public health, safety, morals, and general welfare of the community.

B. Adjacent property

The use and value of the area adjacent to the property included in the development standard variance request will not be affected in a substantially adverse manner.

C. Practical difficulty

The strict application of the terms of the White County Zoning Ordinance would result in practical difficulties in the use of the property.

12.4.8 Additional decision criteria

Additional decision criteria to be considered include the following:

A. Preservation and enjoyment of property

The granting of a variance is necessary for the preservation and enjoyment of a common property right possessed by other property owners in the same vicinity and district.

B. Minimum departure from the development standard

The granting of a variance would be a minimal departure from the strict application of the provisions of the White County Zoning Ordinance. In other words, the variance will be the minimum necessary to permit a reasonable use of the land and building.

C. Preserving the character of the area

The variance being sought does not essentially alter the character of the surrounding area.

1. Self-imposed causation

The variance request is not the result of an act or action, or lack thereof, of the applicant, property owner, contractor or any other party affiliated with the property to which the variance is being sought.

2. Economic gain

The need for the developmental standard variance is not based on a perceived reduction of, or restriction on, economic gain.

12.4.8 Possible action by Area Board of Zoning Appeals

Either at the public hearing or within thirty (30) days after the conclusion thereof, the Area Board of Zoning Appeals shall approve, conditionally approve, disapprove, or continue the request.

A. Approval

The application shall be approved if the Area Board of Zoning Appeals makes Findings of Fact which are consistent with this Chapter and IC 36-7-4-918.5 as amended.

B. Approval with Conditions

The application shall be approved with conditions if the Area Board of Zoning Appeals determines that the required Findings of Fact may be met if the applicant enters into written commitments which are then applied to the development standard variance.

C. Denial

The application shall be denied if Findings of Fact are inconsistent with this Chapter and/or IC 36-7-4-918.5 as amended.

D. Continued

The application may be continued by the Area Board of Zoning Appeals based on a request by the Executive Director, the applicant, a remonstrator, an interested party, by an indecisive vote of the Board, or a determination by the Board that additional information is required prior to taking further action on the request.

12.4.9 Written Findings of Fact

The Area Board of Zoning Appeals shall make a determination in writing of its findings for each application. The Board's findings shall be based upon the decision criteria identified in sub-sections 12.4.7 and 12.4.8 and consistent with IC 36-7-4-918.5. Findings of Fact shall be documented in written form by the Staff, and then signed by the Executive Director and Secretary of the Board at or before the following regularly scheduled meeting. Same Findings shall be provided to the Board for approval as an attachment to the meeting minutes.

12.4.10 Conditions and/or commitments

The Area Board of Zoning Appeals may impose conditions and limitations concerning bulk, height, area, and other matters relating to the purposes and objectives of the White County Zoning Ordinance. Such conditions shall be expressly set forth in the order granting the development standard variance. In addition to prescribing conditions, the Area Board of Zoning Appeals may require the owner of the subject property to make written commitments concerning the use or development of the property in accordance with this Chapter. Violation of any such condition or commitment shall be a violation of the White County Zoning Ordinance and constitutes a civil zoning violation subject to the provisions of Chapter 13, Enforcement.

A. Conditions

In granting any variance, the Area Board of Zoning Appeals may prescribe appropriate and reasonable conditions and safeguards which shall be in conformity with all of the following requirements. Violation of any conditions and safeguards, when made a part of the terms under which the variance is granted, shall be deemed a violation of the White County Zoning Ordinance and grounds for revoking the variance and punishable under the White County Zoning Ordinance.

1. The condition or safeguard must be designed to protect natural resources, the health, safety, and welfare and the social and economic well being of those who will use the land or activity under consideration, residents and landowners immediately adjacent to the proposed land use or activity, and the community as a whole.
2. The condition or safeguard must be related to the valid exercise of the police power, and purposes, which are affected, by the proposed use or activity.
3. The condition or safeguard must be necessary to meet the intent and purposes of the White County Zoning Ordinance, be related to the standards established in the White County Zoning Ordinance for the land use or activity under consideration, and be necessary to insure compliance with those standards.

B. Commitments

The Area Board of Zoning Appeals may accept written commitments concerning the use or development of the property as specified under IC 36-7-4-1015 as amended.

C. Recording conditions and commitments

After review of any conditions or commitments by the Executive Director, or his or her designee, the conditions or commitments shall be recorded, by the applicant, in the White County Records office within ninety (90) days of approval. A copy of the recorded document shall be provided to the Executive Director for inclusion in the petition file prior to the issuance of any Improvement Location Permit.

D. Compliance with conditions and commitments

No Improvement Location Permit shall be issued for any permit application which does not comply with the recorded conditions and/or commitments.

12.4.11 Limitation

Once granted, a development standard variance shall run with the land, unless specifically stated otherwise in the conditions or commitments of the Board's final determination, or until such time as: (1) the property comes into compliance with the White County Ordinance as written, or (2) the variance is terminated, in a public hearing, by the Area Board of Zoning Appeals.

12.4.12 Termination

A development standard variance may be terminated by the Area Board of Zoning Appeals, upon filing of a complaint by an interested person or the Executive Director, and upon finding at public hearing, with notice to the property owner and any other interested parties pursuant to Area Board of Zoning Appeal rules, that the terms of this Chapter or conditions of approval or commitments, have not been complied with. A development standard variance may be terminated by the Area Board of Zoning Appeals under the following procedures.

A. Determination by the Executive Director

In the event that the Executive Director determines that possible grounds exist for the termination of a development standard variance, the Executive Director shall notify the property owner, via Certified Mail, a minimum of ten (10) days, before the public hearing.

B. Public hearing

The Area Board of Zoning Appeals may, in a public hearing, determine if grounds for termination exist. The presentation of reports and testimony and all other aspects of the public hearing shall be consistent with the By-Laws of the Board.

C. Grounds for termination

At the public hearing the development standard variance shall be revoked if a finding is made by the Area Board of Zoning Appeals that one or more of the following is true:

1. Inconsistency with the White County Zoning Ordinance

The execution of the approval is not consistent with a requirement of the White County Zoning Ordinance.

2. Inconsistency with a condition of approval

The execution of the approval is not consistent with any condition of approval.

3. Inconsistency with a written commitment

The execution of the approval is not consistent with any written commitment.

4. Fraud or misrepresentation of facts

The approval was the result of fraud or the misrepresentation of facts.

12.4.13 Revocation of a variance

A development standard variance may be revoked by the Board of Zoning Appeals. A development standards variance shall be deemed automatically null and void if the

property, building, or structure for which the development standard variance was granted is for any reason demolished or destroyed. Thus, a new replacement building or structure shall be required to conform to regulations in effect at that time.

12.4.14 Appeals

Final decisions of the Area Board of Zoning Appeals under the 900 Series of IC 36-7-4 and section 1015 may be subject to judicial review as provided for in the 1600 Series of IC 36-7-4 as amended from time to time. A person must have standing to submit a petition for judicial review of a zoning decision of the Area Board of Zoning Appeals to the appropriate court. The petition shall be presented to the court not later than thirty (30) days after the date of the zoning decision that is the subject of the petition for judicial review. A person who fails to timely object to a zoning decision or timely petition for review a zoning decision within the thirty (30) day period prescribed in this section waives the right to judicial review under this subsection. For purposes of this subsection, the following is applied:

1. "Standing" is determined as provided for in IC 36-7-4-1603 of the 1600 Series as amended from time to time.
2. "Zoning Decision" is defined in IC 36-7-4-1016 of the 1000 Series as amended from time to time.

A person may file a petition for judicial review under this section only after exhausting all administrative remedies available within the Area Board of Zoning Appeals.

12.5 SPECIAL EXCEPTION USE PERMIT

Special Exception Use Permits are intended for those uses that, because of their unique characteristics and potentially adverse impact upon the immediate area, or the County as a whole, require a greater degree of scrutiny. In no case shall any special exception use be authorized without the approval of the Area Board of Zoning Appeals or the Area Plan Hearing Officer. All applications for a Special Exception Use Permit will be heard utilizing the following procedures or, where applicable, the Alternate Procedure outlined in Section 12.16.

12.5.1 Authority

The Area Board of Zoning Appeals may upon petition authorize the granting of a special exception use permit, pursuant to IC 35-7-4-918.2 as amended. A use must be listed as a special exception use in the Official Schedule of Uses, as amended from time to time, in order to be considered for a special exception use permit.

12.5.2 No presumption of approval

The listing of a special exception use within each zoning district shall not constitute an assurance or presumption that such special exception use will be approved. Rather, each proposed special exception use shall be evaluated on an individual basis, in relation to its compliance with the standards and conditions set forth herein and with the development standards for the district in which it is to be located.

12.5.3 Application

The applicant shall submit a special exception use permit application, the required filing fee, and required supporting information to the Executive Director. Supporting information shall include, but shall not be limited to, the following:

A. Dimensional Survey

An applicant shall obtain a dimensional survey of the subject property, prepared by a registered land surveyor, showing the property lines, distances from the property lines to the improvements, easements, existing and proposed structures complete with dimensions, parking, wells, grinders, and septic systems. The dimensional survey shall also include a general description of the land uses within fifty (50) feet of the subject property. Any costs associated in the completion of said survey shall be the responsibility of the applicant. The survey requirement may be waived or modified by the Executive Director.

B. Site plan

A site plan as prescribed by the Executive Director.

C. Written Commitments

Documentation of any written commitments as prescribed by this Chapter, if applicable.

12.5.4 Notification

Notification of public hearing as prescribed by this Chapter.

12.5.5 Action by the Executive Director

Upon receipt of a properly completed application for a special exception use permit, the Executive Director shall transmit to the Area Board of Zoning Appeals all administrative reports and recommendations regarding the proposed application. The application shall be scheduled for a public hearing in accordance with the requirements of this Chapter.

12.5.6 Public hearing

The Area Board of Zoning Appeals shall, in a public hearing scheduled consistent with the adopted Calendar of Filing and Meeting Dates, review the special exception use application and required supporting information. The presentation of reports and testimony and all other aspects of the public hearing shall be consistent with the By-Laws of the Board.

12.5.7 Decision criteria

In taking action on all special exception use permit requests, the Area Board of Zoning Appeals shall use the following decision criteria.

A. Consistency with the Official Schedule of Uses

The proposed special exception use is permitted in the proposed zoning district per the Official Schedule of Uses.

B. Consistency with all applicable development standards

The proposed development, if applicable, conforms to the development standards of the White County Zoning Ordinance.

C. Consistency with the intent of the White County Zoning Ordinance

Granting the special exception use will not be contrary to the general purposes served by the White County Zoning Ordinance, and will not significantly injure other property or uses in the same zoning district.

D. Consistency with the Comprehensive Plan

The proposed use will be consistent with the Comprehensive Plan and the character of the zoning district in which it is located.

12.5.8 Additional decision criteria

The Area Board of Zoning Appeals shall review the particular facts and circumstances of each proposed special exception use application in terms of the following standards and shall find adequate evidence that the proposed special exception use will:

- A. Be designed, constructed, operated, and maintained so as to be harmonious and appropriate in appearance with the existing or intended nature of the general vicinity and will not change the essential character of the same area;
- B. Not be hazardous or disturbing to existing neighboring uses;
- C. Be served adequately by essential public facilities and services such as highways, streets, police and fire protection, drainage structures, refuse disposal, water and sewer, and schools; or that the persons or agencies responsible for the establishment of the proposed use shall be able to provide adequately any such services;
- D. Not create excessive additional requirements at public expense for public facilities and services and will not be detrimental to the economic welfare of the community;
- E. Not involve uses, activities, processes, materials, equipment and conditions of operation that will be significantly detrimental to any persons of interest, property, or the general welfare by reason of excessive production of traffic, noise, smoke, fumes, glare, odors or other related factors;
- F. Have vehicular approaches to the property which shall be so designed as not to create an interference with traffic on surrounding public thoroughfares; and
- G. Not result in the destruction, loss, or damage of a natural, scenic, or historic feature of major importance.

12.5.9 Possible action by the Area Board of Zoning Appeals

At the public hearing, the Area Board of Zoning Appeals shall approve, conditionally approve, disapprove, or continue the request.

A. Approval

The application shall be approved if the Area Board of Zoning Appeals makes Findings of Fact which are consistent with this Chapter and IC 36-7-4-918.5 as amended.

B. Approval with conditions

The application shall be approved with conditions if the Area Board of Zoning Appeals determines that the required Findings of Fact may be met if the applicant enters into written commitments which are then applied to the special exception use permit

C. Denial

The application shall be denied if Findings of Fact are inconsistent with this Chapter and/or IC 36-7-4-918.5 as amended.

D. Continued

The application may be continued by the Area Board of Zoning Appeals based on a request by the Executive Director, the applicant, a remonstrator, an interested party, by an indecisive vote of the Board, or a determination by the Board that additional information is required prior to taking further action on the request.

12.5.10 Written Findings of Fact

The Area Board of Zoning Appeals shall make a determination in writing of its findings for each application. The Board's findings shall be based upon the decision criteria identified in sub-sections 12.5.7 and 12.5.8 above, and consistent with IC 36-7-4-918.2. Findings of fact shall be documented in written form by the staff, and then signed by the Executive Director and Secretary of the Board at or before the following regularly scheduled meeting. Same findings shall be provided to the Board for approval as an attachment to the meeting minutes.

12.5.11 Conditions and/or commitments

The Area Board of Zoning Appeals may impose conditions and limitations concerning use, construction, character, location, landscaping, screening, and other matters relating to the purposes and objectives of the White County Zoning Ordinance. Such conditions shall be expressly set forth in the order granting the special exception. In addition to prescribing conditions, the Area Board of Zoning Appeals may require the owner of the subject property to make written commitments concerning the use or development of the property in accordance with this Chapter. Violation of any such condition or commitment shall be a violation of the White County Zoning Ordinance and subject to the provisions of Chapter 13, Enforcement.

A. Conditions

In granting any special exception use, the Area Board of Zoning Appeals may impose appropriate and reasonable conditions. Violation of any condition, when made a part of the terms under which the special exception use permit is granted, shall be deemed a violation of the White County Zoning Ordinance and grounds for revoking the special exception use permit and punishable under the White County Zoning Ordinance.

1. The condition must be designed to protect natural resources, the health, safety, or welfare and the social or economic well being of those who will use the land or activity under consideration, residents and landowners immediately adjacent to the proposed land use or activity, and the community as a whole.

2. The condition must be related to the valid exercise of the police power, and purposes, which are affected, by the proposed use or activity.
3. The condition must be necessary to meet the intent and purposes of the White County Zoning Ordinance, be related to the standards established in the White County Zoning Ordinance for the land use or activity under consideration, and be necessary to insure compliance with those standards.

B. Commitments

The Area Board of Zoning Appeals may accept written commitments concerning the use or development of the property as specified under IC 36-7-4-1015 as amended from time to time.

C. Recording conditions and commitments

After review of any conditions or commitments by the Executive Director, or his or her designee, the conditions or commitments shall be recorded, by the applicant, in the White County Recorders office within ninety (90) days of approval. A copy of the recorded document shall be provided to the Executive Director for inclusion in the petition file prior to the issuance of any Improvement Location Permit.

D. Compliance with conditions and commitments

No Improvement Location Permit shall be issued for any permit application which does not comply with the recorded conditions and/or commitments.

12.5.12 Limitation

The approval of a proposed special exception use shall not authorize the development, construction, reconstruction, alteration or moving of any building or structure, but shall merely authorize the preparation, filing and processing of applications for such permits or approvals as may be required by the regulations of the County. A special exception use permit shall be deemed to authorize only the particular use at the particular location for which the special exception use was granted. Once granted, a special exception use shall run with the land, unless specifically stated otherwise in the conditions or commitments of the Board's final determination, or until such time as:

- A. The use comes into compliance with the White County Ordinance as written; or
- B. The use is terminated, in a public hearing, by the Area Board of Zoning Appeals.
- C. In addition, a special exception use approved by the Board may not be expanded, extended, or enlarged unless it is:
- D. Re-approved by the Board under the procedures set forth in this Chapter; OR
- E. Incidental as determined by the Executive director; OR
- F. Increasing the total area of structures and buildings by less than 50% of the most recently Area Board of Zoning Appeals-approved site development plan. Such authorization shall be in writing from the Executive Director.

12.5.13 Termination

A special exception use may be terminated by the Area Board of Zoning Appeals, upon filing of a complaint by an interested person or the Executive Director, and upon finding at a public hearing, with notice to the property owner and any other interested parties pursuant to Area Board of Zoning Appeal rules or By-Laws, that the terms of this Chapter or conditions of approval or commitments, have not been complied with. A special exception use permit may be terminated by the Area Board of Zoning Appeals under the following procedures.

A. Determination by the Executive Director

In the event that the Executive Director determines that possible grounds exist for the termination of a special exception use, the Executive Director shall notify the applicant, via Certified Mail, a minimum of ten (10) days, before the public hearing.

B. Public Hearing

The Area Board of Zoning Appeals may, in a public hearing, determine if grounds for termination exist. The presentation of reports and testimony and all other aspects of the public hearing shall be consistent with the By-Laws of the Board.

C. Grounds for Termination

At the public hearing the special exception use shall be revoked if a finding is made by the Area Board of Zoning Appeals that one or more of the following is true:

1. Inconsistency with the White County Zoning Ordinance

The execution of the approval is not consistent with a requirement of the White County Zoning Ordinance.

2. Inconsistency with a condition of approval

The execution of the approval is not consistent with any condition of approval

3. Inconsistency with a written commitment

The execution of the approval is not consistent with any written commitment

4. Fraud or misrepresentation of facts

The approval was the result of fraud or the misrepresentation of facts.

5. Discontinued or abandoned use

The special exception use is discontinued or abandoned for a period of twelve (12) months.

12.5.14 Appeals

Final decisions of the Area Board of Zoning Appeals under the 900 Series of IC 36-7-4 and section 1015 may be subject to judicial review as provided for in the 1600 Series of IC 36-7-4 as amended from time to time. A person must have standing to submit a petition for judicial review of a zoning decision of the Area Board of Zoning Appeals to the appropriate court. The petition shall be presented to the court not later than thirty (30) days after the date of the zoning decision that is the subject of the petition for

judicial review. A person who fails to timely object to a zoning decision or timely petition for review a zoning decision within the thirty (30) day period prescribed in this section waives the right to judicial review under this subsection. For purposes of this subsection, the following is applied:

1. "Standing" is determined as provided for in IC 36-7-4-1603 of the 1600 Series as amended from time to time.
2. "Zoning Decision" is defined in IC 36-7-4-1016 of the 1000 Series as amended from time to time.

A person may file a petition for judicial review under this section only after exhausting all administrative remedies available within the Area Board of Zoning Appeals. APPEAL of an Administrative decision

12.6 APPEAL OF AN ADMINISTRATIVE DECISION

12.6.1 Purpose

- A. The appeal procedure is provided as a safeguard against arbitrary or erroneous administrative decisions. It is intended to avoid the need for legal action by establishing local procedures to review and correct administrative errors. It is not, however, intended as a means to subvert the clear purposes, meanings, or intent of the White County Zoning Ordinance or the rightful authority of the Executive Director to enforce the requirements of the White County Zoning Ordinance. To these ends, the reviewing body shall give all proper deference to the spirit and intent embodied in the language of the White County Zoning Ordinance and to the reasonable interpretations of that language by those charged with the administration of the White County Zoning Ordinance.
- B. The filing of an appeal shall stay all proceedings in furtherance of the action appealed from, unless the Executive Director certifies to the Area Board of Zoning Appeals, after the notice of appeal has been filed, that by reason of facts stated in the certificate, a stay would cause, in his or her opinion, imminent peril to life or property, in which case the proceedings shall not be stayed otherwise than by a restraining order that may be granted by the Area Board of Zoning Appeals or by a court of record, on application, of notice to the Executive Director and on due cause shown.
- C. The Area Board of Zoning Appeals may reverse or affirm, wholly or partly, or may modify the interpretation order or final decision as in its opinion ought to be made. To that end the Area Board of Zoning Appeals has all the powers of the officer from whom the appeal is taken.

12.6.2 Authority

The Area Board of Zoning Appeals may grant an appeal of any decision, interpretation, or determination made by the Executive Director or any other administrative official or board charged with the duty of enforcing and interpreting the White County Zoning Ordinance.

12.6.3 Parties entitled to appeal

Appeals to the Area Board of Zoning Appeals concerning the interpretation or administration of the White County Zoning Ordinance may be taken by any persons aggrieved or affected by any decision of the Executive Director or any other administrative official or board charged with the duty of enforcing and interpreting the White County Zoning Ordinance.

12.6.4 Application

A person shall submit an administrative appeal application and required supporting information to the staff no later than thirty (30) days of the decision in question. The application shall be in accordance with the requirements of this Chapter. Supporting information shall include, but is not limited to, the following:

- A. Original Submittals
Copies of all materials upon which the decision being appealed was based.
- B. Written Decisions
Copies of any written decisions that are the subject of the appeal.
- C. Appeal Basis
A letter describing the reasons for the appeal noting specific situations of the White County Ordinance or other requirements upon which the appeal is based.

12.6.5 Action by the Executive Director

The Executive Director shall provide to the Board all documentation constituting the record from which the action appealed was taken.

12.6.6 Notification

Notification of public hearing as prescribed by this Chapter.

12.6.7 Possible action by the Board of Zoning Appeals

The Area Board of Zoning Appeals shall hold a public hearing in which it reviews all applicable documentation. The Area Board of Zoning Appeals shall render a written decision on the appeal. Such decision may reverse, modify (in whole or in part), affirm, or continue the appeal of the administrative action.

- A. Reverse
The administrative decision shall be reversed if Findings of Fact are made that the applicant is in compliance with the requirements of the White County Zoning Ordinance and Indiana State Code.
- B. Modify
The administrative decision shall be modified if the Area Board of Zoning Appeals determines that the proper interpretation of the provision(s) identified in the appeal is/are inconsistent with either the administrative decision or the requested interpretation of the ordinance.

C. Affirm

The administrative decision shall be affirmed if Findings of Fact are made supporting the administrative decision.

D. Continue

The appeal shall be continued based on: a request by the Executive Director or the applicant; an indecisive vote; or a determination by the Board that additional information is required prior to action being taken on the request. The continuing of all applications shall be consistent with the adopted By-Laws for the Area Board of Zoning Appeals.

12.6.8 Review by Judicial Review

Final decisions of the Area Board of Zoning Appeals under the 900 Series of IC 36-7-4 and section 1015 may be subject to judicial review as provided for in the 1600 Series of IC 36-7-4 as amended from time to time. A person must have standing to submit a petition for judicial review of a zoning decision of the Area Board of Zoning Appeals to the appropriate court. The petition shall be presented to the court not later than thirty (30) days after the date of the zoning decision that is the subject of the petition for judicial review. A person who fails to timely object to a zoning decision or timely petition for review a zoning decision within the thirty (30) day period prescribed in this section waives the right to judicial review under this subsection. For purposes of this subsection, the following is applied:

1. "Standing" is determined as provided for in IC 36-7-4-1603 of the 1600 Series as amended from time to time.
2. "Zoning Decision" is defined in IC 36-7-4-1016 of the 1000 Series as amended from time to time.

A person may file a petition for judicial review under this section only after exhausting all administrative remedies available within the Area Board of Zoning Appeals.

12.6.9 Right to grant variance in deciding appeals

In any case where the application for appeal is accompanied by an application for a variance in accordance with the White County Zoning Ordinance, the Area Board of Zoning Appeals shall notice, hear, and decide to grant or deny, such variance in compliance with the provisions of this Chapter.

12.6.10 Conditions and limitations on rights granted by appeal

In any case where the White County Zoning Ordinance imposes conditions and limitations upon any right, any such right granted by appeal shall be subject to such conditions and limitations in the same manner and to the same extent as if secured without the necessity of an appeal.

12.7 ZONING ORDINANCE AMENDMENT

12.7.1 Purpose

The purpose of this Section is to provide standards and procedures for making amendments to the text of the White County Zoning Ordinance that are of general

significance or application. This amendment process is not intended to relieve particular hardships nor to confer special privileges or rights upon any person, but only to make adjustments necessary in light of changing community conditions, changes in public policy, fact of law or cultural changes recognized by the Board.

12.7.2 Authority

The text of the White County Zoning Ordinance may be amended from time to time by the passage of an Ordinance duly adopted by the appropriate legislative body in accordance with the Rules of Procedure of the White County Area Plan Commission and the appropriate legislative body.

12.7.3 Parties entitled to initiate amendments

Amendments to the White County Zoning Ordinance may be initiated by the Staff, the Area Plan Commission or a legislative body.

12.7.4 Approval

Regardless of whether an amendment is initiated by the Executive Director, Area Plan Commission or legislative body, the application must first go to the Area Plan commission for consideration before any action can be taken by the legislative body.

Any amendment initiated will be heard at a public meeting within sixty (60) days of the proposed amendment being filed with the Staff.

Within ten (10) business days after the Area Plan Commission determines its recommendation, if any, the Staff shall certify the proposal to each participating legislative body with a favorable, unfavorable or no recommendation.

The legislative body shall vote on the proposal within ninety (90) days after the Plan Commission certifies the proposal to said body.

A. Proposals which receive a favorable recommendation

1. At the first regular meeting of the legislative body after the proposal is certified (or at any subsequent meeting with the ninety (90) day period), the legislative body may adopt, reject or amend the proposal. The legislative body shall give notice under IC 5-14-1.5-5 of its intention to consider the proposal at that meeting.
 - a. If the legislative body adopts the proposal as certified, it takes effect as other ordinances of the legislative body.
 - b. If the legislative body fails to act on the proposal within ninety (90) days after certification, it takes effect as if it had been adopted as certified.
 - c. If the legislative body rejects or amends the proposal, it shall be returned to the Plan Commission for its consideration with a written statement of the reasons for the rejection or amendment. The Commission has forty-five (45) days in which to consider the rejection or amendment and report to the legislative body as follows:
 1. If the Commission approves the amendment or fails to act within the forty-five (45) day period, the ordinance stands as passed by the

legislative body and it takes effect on the date of approval or the end of the forty-five (45) day period.

2. If the Commission disapproves the rejection or amendment, the action of the legislative body on the original rejection or amendment stands only if confirmed by another vote of the legislative body within forty-five (45) days after certification of its disapproval. If the legislative body fails to act within the forty-five (45) days after the Commission certifies its disapproval, the amendment passes as originally certified.

B. Proposals which receive an unfavorable or no recommendation

1. At the first regular meeting of the legislative body after the proposal is certified (or at any subsequent meeting within the ninety (90) day period), the legislative body may adopt, reject or amend the proposal. The legislative body shall give notice under IC 5-14-1.5-5 of its intention to consider the proposal at that meeting.
 - a. If the legislative body adopts the proposal as certified, it takes effect as other ordinances of the legislative body.
 - b. If the legislative body fails to act on the proposal within ninety (90) days after certification, it takes effect as if it had been adopted as certified.
 - c. If the legislative body rejects the proposal or fails to act on it within ninety (90) days after certification, it is defeated.
 - d. If the legislative body amends the proposal, it shall be returned to the Plan Commission for its consideration, with a written statement of the reasons for the amendment. The Commission has forty-five (45) days in which to consider the rejection or amendment and report to the legislative body as follows:
 1. If the commission approves the amendment or fails to act within forty-five (45) day period, the ordinance stands as passed by the legislative body and it takes effect on the date of approval or the end of the forty-five (45) day period.
 2. If the Commission disapproves the rejection or amendment, the action of the legislative body on the original rejection or amendment stands only if confirmed by another vote of the legislative body within forty-five (45) days after certification of its disapproval. If the legislative body fails to act within the forty-five (45) days after the Commission certifies its disapproval, the amendment passes as originally certified.

Once adopted, the amendment must be signed and attested. The Staff will see that the County Commissioners adoption is recorded.

12.8 ZONING MAP AMENDMENT (REZONING)

12.8.1 Purpose

The purpose of this Section is to provide standards and procedures for making amendments to the Zoning Map that are of general significance or application. This amendment process is not intended to relieve particular hardships nor to confer special

privileges or rights upon any person, but only to make necessary adjustments in light of changes in community conditions, fact of law or public policy.

12.8.2 Authority

The Zoning Map may be amended from time to time by the passage of an Ordinance duly adopted by the appropriate legislative body in accordance with the procedures set forth in this Chapter.

Any parcel legally rezoned for a specific use and which has lost its conformance status due to a zoning ordinance change, may be reclassified to the proper current zoning district for that use at the discretion of the Executive Director.

12.8.3 Parties entitled to initiate amendments

Amendments to the Zoning Map, which is otherwise referred to as a rezoning, may be initiated by adoption of a motion of the Area Plan Commission, by adoption of a motion by the appropriate legislative body; or by the filing of a petition by at least fifty (50) percent of the owners of property within the area proposed to be changed or affected by said amendment, in accordance with IC 36-7-4-602(c)(1)(B).

A. Rezoning initiated by the Area Plan Commission or appropriate legislative body
The Executive Director shall prepare the application and be the hearing representative for a zoning map amendment if either the Area Plan Commission or the legislative body initiates the rezone request. The Executive Director shall serve as the applicant’s representative.

B. Rezoning initiated by property owner(s) or designee
Any property owner(s) requesting a zoning map amendment shall assume responsibility of preparing, submitting and representing the application or authorize an agent to execute the actions necessary to prepare, submit and present the rezone application to the Area Plan Staff, Area Plan Commission and appropriate legislative body.

In a case where a property owner(s) desires to have their property(ies) rezoned but wish to have an agent act on their behalf, the property owner(s) must provide a notarized letter to the Staff identifying who the acting agent is to be and the substance of the request. Such letter must include the following verbiage in the content of said letter:

“(I/We), _____, desire to have our property(ies) rezoned from

Property Owner’s Name(s)

_____ to _____. (My/Our) property(ies) are identified as

Zoning District

Zoning District

_____, more commonly known as _____.

Parcel Identification Number(s)

Full Address

(I/We) are authorizing _____ -- _____ to act on (my/our)

(Name – Relationship/Title)

behalf in all phases of executing the rezone request.”

The letter must be signed by at least one of the property owners, dated and notarized by a licensed notary. This letter will become a part of the official record and stands until such time as the rezone request has received final action by the appropriate legislative body.

12.8.4 Application

The applicant shall submit a rezoning application, a legal description for the property or properties, the required filing fee, and any supporting documentation to the office of the Area Plan Commission. Supporting documentation includes, but is not limited to the following:

A. Site Plan

A conceptual site plan showing all features relevant to the application.

B. Letter of Intent

A letter of intent to the Plan Commission stating the reasons for the rezoning, including a detailed description of any proposed development for which the rezoning is sought. The letter should include any written commitments being made by the applicant.

12.8.5 Notification

Notification of public hearing will be as prescribed by this Chapter.

12.8.6 Public hearing

The Area Plan Commission shall hold a public hearing on the application in accordance with the Commission's Rules of Procedure and as prescribed by the White County Zoning Ordinance. The public meeting shall be held on a date consistent with the published Calendar of Filing and Meeting Dates, provided that the meeting is no later than 60 days upon receipt of a complete application packet and filing fee. The presentation of reports and testimony and all other aspects of the public hearing shall be consistent with the Area Plan Commission's Rules of Procedure.

12.8.7 Decision criteria

The wisdom of amending the Zoning Map is a matter committed to the sound legislative discretion of the appropriate legislative body and is not controlled by any one (1) standard or district. The Area Plan Commission should, in determining whether to favorably recommend, unfavorably recommend, or forward with no recommendation consider the following:

A. Planning efforts

Whether the proposed rezoning is consistent with the goals, objectives, and policies of the White County Strategic Plan and any other applicable planning studies and reports, as adopted and amended from time to time;

B. Current conditions

Whether the proposed rezoning is compatible with current conditions (e.g. existing lots, structures and uses) and the overall character of existing development in the immediate vicinity of the subject property;

C. Desired use

Whether the proposed rezoning is the most desirable use for which the land in the subject property is adapted;

D. Property values

Whether the proposed rezoning will have an adverse effect on the value of properties throughout the jurisdiction; and

E. Responsible growth

Whether the proposed rezoning reflects responsible standards for growth and development.

Regardless of whether a rezone request is initiated by the property owner, the Area Plan Commission or the legislative body, the proposal must be referred to the Area Plan Commission for consideration and recommendation before any final action is taken by the legislative body.

12.8.8 Possible action by the Area Plan Commission

Within sixty (60) days after receipt of the rezoning application, the Area Plan Commission shall hold a hearing at which they will determine a favorable recommendation, an unfavorable recommendation, or no recommendation, or the Commission may continue the request.

A. Favorable recommendation

The application shall be forwarded with a favorable recommendation if it is found to be consistent with the decision criteria listed sub-section 12.8.7 above. The recommendation may include written commitments proposed by the applicant and/or requested by the Plan Commission.

B. Unfavorable recommendation

The application shall be forwarded with an unfavorable recommendation if it is found to be inconsistent with the decision criteria listed in sub-section 12.8.7above.

C. No recommendation

The application may be forwarded with no recommendation if, by a majority vote of the Commission, it is determined that the application includes aspects that the Commission is not able to evaluate.

D. Continued

The application may be continued by the Commission based on a request by the Executive Director, an applicant, a remonstrator, or other interested party; an indecisive vote; or a determination by the Commission that additional information is required prior to action being taken on the request. An applicant or

remonstrator may request only one (1) continuance; petitions may be continued as needed by the Executive Director, or the Area Plan Commission.

12.8.9 Certification by the Area Plan Commission

Within ten (10) business days of its determination, the Staff shall certify the Commission's recommendation (including no recommendation) to the appropriate legislative body, by resolution in accordance with IC 36-7-4-608 as amended.

12.8.10 Possible action by the appropriate legislative body

The legislative body shall vote on the proposal within ninety (90) days after the recommendation of the Area Plan Commission has been certified to the legislative body.

- A. Proposals certified with a favorable recommendation
 - 1. If the legislative body adopts the proposal as certified, it takes effect as other ordinances of the legislative body.
 - 2. If the legislative body rejects the proposal, it is defeated,
 - 3. If the legislative body fails to act on the proposal within ninety (90) days after certification, the ordinance takes effect as if it had been adopted as certified ninety (90) days after certification.
- B. Proposals certified with either an unfavorable recommendation or no recommendation
 - 1. If the legislative body adopts the proposal as certified, the rezone is defeated.
 - 2. If the legislative body rejects the proposal, the rezone is granted.
 - 3. If the legislative body fails to act on the proposal within ninety (90) days after certification, the rezone is defeated.

12.8.11 Effective date

An amendment to the zoning map shall become effective immediately upon adoption by the appropriate legislative body, provided that there are no written commitments. Zoning map amendments with commitments shall become effective as provided for in Section 12.8.12 (B) of this Chapter.

12.8.12 Written commitments

Consistent with IC 36-7-4-1015 as amended, the applicant in any rezoning application may make written commitments regarding the use or development of that parcel. Written commitments may also be initiated by the Plan Commission or appropriate legislative body.

A. Consideration of Commitments

All commitments shall be considered by the Area Plan Commission and the appropriate legislative body in the review of the rezoning application. Any deletion or modification of the written commitments by the appropriate legislative body shall be referred back to the Area Plan Commission for ratification only if such deletion or modification makes the commitment less stringent.

1. Area Plan Commission Ratifies

If the Commission ratifies the modification(s) to the commitments, the rezoning ordinance adoption is complete.

2. Area Plan Commission Disagrees

If the Commission disagrees with the modification(s) to the commitments, the Commission shall forward its reasoning, in writing, to the appropriate legislative body. The rezoning, including the modified commitments, shall take effect if the appropriate legislative body again votes for its adoption.

- B. Documentation of Commitments

The rezoning ordinance shall not become effective until the written commitments are recorded. The written commitments shall be recorded along with the rezoning ordinance, by the applicant, in the office of the White County Recorder within ninety (90) days of the adoption of the rezoning ordinance. A recorded copy of the commitments shall be provided to the Executive Director for inclusion in the application file within that same ninety (90) day time period. The adoption of the rezoning ordinance shall not take effect and shall be void if the commitments and rezoning ordinance are not recorded in the ninety (90) day time period.

- C. Enforcement of Commitments

The written commitments shall be binding on the property owner making the commitment. The written commitments, once recorded, shall be binding on the owner of the subject property, any subsequent owners of the subject property, and any person or entity that acquires an interest in the subject property, or portion thereof. The written commitments shall be enforceable by the Area Plan Commission or Executive Director consistent with the provisions of the White County Zoning Ordinance.

- D. Modification of the adopted written commitments

Except for a commitment that expires or automatically terminates as provided for within the commitment, a commitment may be modified or terminated only by a decision of the Area Plan Commission or Area Board of Zoning Appeals, to whichever the commitment was made.

12.9 ZONING ORDINANCE INTERPRETATION

The interpretation authority established by this Chapter is intended to recognize that the provisions of the White County Zoning Ordinance, though detailed and extensive, cannot, as a practical matter, address every specific situation to which they may have to be applied. Many such situations can be readily addressed by an interpretation of the specific provisions of the White County Zoning Ordinance in light of the general and specific purposes for which those provisions have been enacted. Because the interpretation authority established is an administrative rather than a legislative authority, it is not intended to add to or change the essential content of the White County Zoning Ordinance, but is intended only to allow authoritative application of that content to specific cases.

12.9.1 Authority

The Executive Director or his/her designee, subject to the procedures, standards, and limitations of this Chapter may, by written order, render interpretations, including use interpretations, of the provisions of the White County Zoning Ordinance and of any rule or regulation issued pursuant to it.

12.9.2 Parties entitled to seek interpretations

Applications for interpretations may be filed by any person having a legal or equitable interest in a property that gives rise to the need for an interpretation, provided that interpretations shall not be sought by any person based solely on hypothetical circumstances or where the interpretation would have no effect other than as an advisory opinion.

12.9.3 Application Requests

Requests for Interpretations of the White County Zoning Ordinance shall be filed with the Executive Director of the Area Plan Department.

12.9.4 Decision criteria

In taking action on all ordinance interpretation requests, the Executive Director shall use the following decision criteria.

- A. Any use defined in Chapter 14, Definitions, of the White County Zoning Ordinance shall be interpreted as therein defined;
- B. No use interpretation shall permit any use in any district unless evidence shall be presented that demonstrates that it will comply with the general district regulations established for that particular district;
- C. No use interpretation shall permit any use in a district unless such use is similar to other uses permitted in the district and is more similar to those uses than to uses permitted in a less restrictive district;
- D. If the proposed use is most similar to a use permitted only as a special exception in the district in which it is proposed to be located, then any use interpretation permitting such use shall be conditioned on the issuance of a special exception use permit, pursuant to this Chapter, for such use;
- E. No use interpretation shall permit the establishment of any use that would be inconsistent with the statement of purpose of the district in question.

12.9.5 Possible action by the Executive Director

Within ten (10) working days following the receipt of a written ordinance interpretation request, or within a longer period of time mutually acceptable to both parties, the Executive Director shall inform the applicant, in writing, of his/her interpretation, stating the specific precedent, reasons, and analysis upon which the determination is based. Failure of the Executive Director to act within ten (10) working days, or the mutually agreed upon time, shall be deemed to be a decision denying the request.

12.9.6 Recording

A record of all requests for interpretations, and the interpretation itself shall be kept on file in the office of the Area Plan Commission.

12.9.7 Limitations on use interpretations

Subject to an extension of time granted by the Executive Director, no use interpretation shall be valid for a period longer than twelve (12) months from the date of issuance. An interpretation finding a use to be permitted, or permitted as a special exception use in a particular district, shall be deemed to authorize only the particular use for which it was issued and such permit shall not be deemed to authorize any allegedly similar use for which a separate use interpretation has not been issued.

12.9.8 Appeals

Appeals of interpretations rendered by the Executive Director may be taken to the Board of Zoning Appeals as prescribed by this Chapter.

12.10 PLANNED UNIT DEVELOPMENT

As prescribed by Chapter 5, Planned Unit Development of the White County Zoning Ordinance.

12.11 IMPROVEMENT LOCATION PERMIT

No structure shall be erected, moved, added to, or structurally altered without an Improvement Location Permit issued by the Area Plan Staff unless specifically exempted elsewhere in this Ordinance. No Improvement Location Permit shall be issued by Staff except in conformance with the provisions of this Chapter, unless by written order from the Board of Zoning Appeals or Hearing Officer in the form of an administrative appeal, Special Exception Use, or Variance as provided by the White County Zoning Ordinance.

12.11.1 Improvement Location Permit required

An Improvement Location Permit shall be obtained for any of the following actions. A single Improvement Location Permit may be issued for a combination of these actions, if they are applied for simultaneously:

A. New construction – Principal Structure

Construction of, additions to, alterations of, placement of or re-location of any principal structure excluding normal & routine maintenance

B. Construction of towers, turbines, antennas, dishes, similar structures

Construction or modification of any wind turbine, communication, meteorological or WECS tower, antenna (excluding antennas for residential uses), flag poles, poles to which sirens or other similar devices are attached, or satellite dish (with a diameter greater than two (2) feet).

C. Remodel

Remodel of any existing structure which affects any development standard specified in Appendix B.

- D. Alteration of required landscaping
Removal of required trees and plants within buffer yards and landscaping areas required by the White County Zoning Ordinance
- E. Alteration of off-street parking
Construction and/or redesign of an off-street parking area, excluding agricultural uses and single and two-family residential uses
- F. Placement of a manufactured or mobile home other than in an Indiana State Regulated Mobile Home Park.

12.11.2 Improvement Location Permit not required

No Improvement Location Permit shall be required for the following types of improvements. Such improvements shall comply with any applicable requirements of the White County Zoning Ordinance, the White County Subdivision Control Ordinance, and any other applicable regulations of White County or the appropriate legislative body unless specifically exempted in this Ordinance:

- A. Accessory structures 120 square feet or less;
- B. Sidewalks, steps/stairs, retaining walls and patios (exempt from setback specifications provided for in Appendix B, Bulk Use Standards);
- C. Non-structural, cosmetic changes to any structure including the replacement of windows in existing openings, re-roofing without a roof-line change, the installation of siding material, and repainting.
- D. Tents, temporary commercial structures, non-permanent or portable concession stands (exempt from setback specifications provided for in Appendix B, Bulk Use Standards);
- E. Piers, boat docks and boat houses (exempt from setback specifications provided for in Appendix B, Bulk Use Standards);
- F. Grain legs and portable grain dryers (exempt from setback specifications provided for in Appendix B, Bulk Use Standards);
- G. Mailbox and Newspaper holders and structures (exempt from setback specifications provided for in Appendix B, Bulk Use Standards);
- H. Seasonal ornaments (exempt from setback specifications provided for in Appendix B, Bulk Use Standards);
- I. Yard ornaments and landscaping (exempt from setback specifications provided for in Appendix B, Bulk Use Standards);
- J. Children's playground equipment (exempt from setback specifications provided for in Appendix B, Bulk Use Standards);
- K. Air conditioning, heating and power generators utilized as an attached accessory to a principal structure and which is a minimum of 2' from any property line (exempt from setback specifications provided for in Appendix B, Bulk Use Standards), and,

- L. Satellite Dish Antennas (Two (2) feet or less in diameter) (exempt from setback specifications provided for in Appendix B, Bulk Use Standards);

12.11.3 Application

Each application for an Improvement Location Permit shall be accompanied by these supporting documents as required by the Executive Director to be deemed a complete application.

- A. Site Plan
As prescribed by the White County Zoning Ordinance or as required by the Staff
- B. Waste disposal verification (if applicable)
Health department approval for any sewage disposal or water supply, where applicable
- C. Use description
A description of any existing and proposed uses of the property
- D. Dwelling units/tenant spaces (if applicable)
An indication of the number of dwelling units, or tenant spaces, the building(s) are intended to accommodate.
- E. Other
Such other information, as may be required by the Area Plan Commission's Executive Director for proper enforcement of the White County Zoning Ordinance.

12.11.4 Action by the Executive Director (and/or his or her designee)

The Executive Director, and/or his or her designee, shall approve, conditionally approve, or disapprove the application based on the following criteria.

- A. Approved
If the application is approved, the Staff shall issue a placard to the applicant. The placard is to be posted in a conspicuous place on the property in question and will attest to the fact that the plans for construction or alteration are in compliance with the provisions of the White County Zoning Ordinance.
- B. Conditionally approve
If after receipt of a complete application for an Improvement Location permit, the Staff finds that the applicant has not fully met the standards set in the White County Zoning Ordinance, and the changes or additional actions needed are deemed by the Staff to be relatively minor or simple, the Staff may issue a conditional approval stating the conditions which must be met prior to the issuance of an Improvement Location Permit, and the reasons for such changes clearly stated in writing. If the applicant agrees, in writing, to the conditions of approval,

the application is amended accordingly. If the applicant does not agree to the conditions, the application is denied.

C. Disapproved

If the application is disapproved, the Staff shall notify the applicant indicating the reasons for the disapproval.

12.11.5 Expiration of an Improvement Location Permit

A. Initiation of work

If the work described in any Improvement Location Permit has not begun within three (3) years from the date which the first application related to the project was filed, the permit shall expire; and shall be canceled by the Area Plan Commission or its Staff.

B. Completion of work

If the work described in any Improvement Location Permit has not been completed within ten (10) years of the date in which the first application related to the project was filed, the permit shall expire and be canceled by the Area Planning Commission or its Staff and written notice thereof shall be given to the persons affected, together with notice that future work as described in the canceled permit or an extension shall not proceed unless and until a new Improvement Location Permit has been obtained.

12.11.6 Failure to obtain an Improvement Location Permit

The failure to obtain an Improvement Location Permit as required by the White County Zoning Ordinance shall be deemed a violation of the White County Zoning Ordinance and subject to the provisions of Chapter 13, Enforcement. Where an Improvement Location Permit is required, any person or persons who initiate location, construction or alteration of a structure prior to obtaining an Improvement Location Permit or any other required permit shall be subject to the fines and penalties of the White County Zoning Ordinance.

12.11.7 Limitations

Improvement Location Permits issued on the basis of plans and applications approved by the Staff authorize only the use or arrangement set forth in such approved application or amendments, and no other use, arrangements, or construction is permitted. Any use, arrangement, or construction contrary to that authorized shall be deemed a violation of the White County Zoning Ordinance and subject to the provisions of Chapter 13, Enforcement.

12.11.8 Recording

Every Improvement Location Permit issued pursuant to this Chapter shall be kept on file in the office of the Area Plan Commission for the period as specified by Indiana State Code and shall be available as public record.

12.12 CERTIFICATE OF OCCUPANCY PERMIT

It shall be unlawful to use or occupy, or to permit the use or occupancy of any building or premises, or both, or part thereof hereafter created, erected, changed, converted, or wholly or partly altered or enlarged in its use or structure until a Certificate of Occupancy has been issued by the Building Inspector. The Certificate of Occupancy shall state that the proposed use of the building and/or land conforms to the requirements of the White County Zoning Ordinance and that the Building Inspector or his/her representative has inspected the property and attested to that fact.

12.12.1 Issuance and recording

The issuance and recording of a Change of Occupancy Permit shall be in conformance with the White County Building Code administered by the White County Building Department.

12.12.2 Failure to obtain a Certificate of Occupancy Permit

It shall hereby be declared unlawful and in violation of the provisions of this Chapter for any builder or property owner to allow any structure to become occupied prior to the following:

- A. Obtaining a building permit from the Building Department
- B. Obtaining an Improvement Location Permit from the Staff
- C. Passing a final inspection by the Building Inspector
- D. Receiving a Certificate of Occupancy Permit from the Building Inspector or his/her representative

12.13 SITE DEVELOPMENT PLAN REVIEW

12.13.1 Purpose

Site development plan review is required to promote orderly development and redevelopment in the County and to ensure that such development is in harmony with surrounding properties and consistent with the general welfare and the policies in the Comprehensive Plan. The procedures set forth in this Chapter are used for determining whether new development or redevelopment is in compliance with the standards of the White County Zoning Ordinance. This Section provides standards by which submission and approval of site plans, for access control, lighting, signage, and landscaping of a lot or parcel of land are submitted in a manner which achieves the following purposes:

- A. Compatibility of land uses, buildings and structures;
- B. Protection and enhancement of property values;
- C. Efficient use of land;
- D. Minimization of traffic to promote safety; and
- E. Minimization of environmental problems.

12.13.2 Applicability and authority

- A. Site development plan review shall be required for any agricultural, commercial, industrial, multi-family, amusement and entertainment park developments, and condominiums prior to the issuance of an Improvement Location Permit or a Building Permit for the following development situations:
1. Any new principal structures;
 2. An existing principal structure is proposed to be expanded more than twenty-five (25) percent of the gross area of the existing structure;
 3. Any new or modified building and/or site improvements for a zoning lot that has previously received site development plan approval under the White County Zoning Ordinance. Re-approval of the plan is required for components of the plan, which depart from the approved site development plan. The extent of required documentation of any proposed changes to be incorporated in the submittal for re-approval shall be determined by the Executive Director;
 4. Any new or modified off-street parking or loading area improvements;
 5. A site development plan shall not be required solely because of a change in the use except where such change of use results in increased off-street parking requirements that cannot currently be met on the site.
 6. In accordance with Chapter 2, District Boundaries and Standards, of the White County Zoning Ordinance no building or structure which has been damaged by fire, explosion, or act of God to the extent of more than fifty (50) percent of its assessed value, shall be restored except in conformity with the regulations of the District in which it is located.
- B. Site development plans may be approved by the Staff in accordance with the procedural provisions of this Section. Any site development plan requiring a variance shall not receive an Improvement Location Permit until approval of the variance is granted by the Area Board of Zoning Appeals.

12.13.3 Initiation

A request for site development plan approval may be made by the owner or owners representative intending to request an Improvement Location Permit under the requirements of this Section.

12.13.4 Submission

The owner of the property or a duly authorized representative of the owner shall file a site development plan for approval with the Staff.

12.13.5 Content Requirements

All documents and information submitted as part of an application for site development plan approval constitute a statement by the applicant, property owner and developer/contractor that he or she intends and agrees to be bound to develop in accordance with such information upon approval. Site development plans shall include the following information unless waived or modified by the Executive Director:

- A. Contact information for the applicant and owners
- Name, address and telephone number of the applicant, including the name and address of each person or entity owning an interest in the applicant or owner and the extent of such ownership interest unless any of such entities is a corporation or a partnership, in which case only those persons owning an interest in excess of ten (10) percent in such corporation or partnership need to be identified by name, address and extent of interest. For purposes of this Section the term ownership interest shall include any legal or equitable interest held at the time of application in the real property which is the subject of the application. The application shall include the signatures of the owner(s). Completed application form provided by the Office of the Area Plan Commission, the property owner and the developer/contractor. In the case where an applicant or owner is a corporation or non-profit group, a contact name, address and phone number must be included.
- B. Each application shall include the required number of full sized documents and drawings as prescribed by this Chapter, to the Office of the Area Plan Commission at the time the application is filed.
- C. The names and addresses of persons and/or firm responsible for preparing the plan.
- D. A site plan drawing including the following:
1. Date, north point and scale;
 2. The dimensions of all lot and property lines, showing the relationship of the subject property to abutting properties and buildings within fifty (50) feet or one property owner deep, whichever is less;
 3. Boundary lines of adjacent tracts of land, showing owners of record;
 4. Legal description of the parcel;
 5. Existing and proposed easements;
 6. The location of existing and/or proposed fire hydrants;
 7. For a site which includes existing structures or improvements, an indication of those improvements that are to remain and those which will be removed;
 8. Underground storage tanks, if any;
 9. General alignment and lengths of all streets and all property lines;
 10. All building restriction lines, highway setback lines, easements, covenants, reservations and rights-of-way;
 11. Streets, using the classification in the Subdivision Control Ordinance: alleys; easements and utilities, including street lighting and underground conduits for street lighting;
 12. Driveways, entrances, exits, parking areas and sidewalks;
 13. Calculations of the following, as applicable:

- a. Number of dwelling units or square footage of non-residential uses;
 - b. Number of parking spaces; and
 - c. Number of loading spaces.
14. Project name by which the project shall be legally or commonly known.
 15. Location, widths, and type of construction of all existing and proposed streets, street names, alleys, or other public ways and easements, railroad and utility rights-of way or easements, parks, wooded areas, cemeteries, water courses, drainage ditches, swamps, low areas subject to flooding, permanent buildings, bridges, and other data considered pertinent by the Area Plan Commission or the Executive Director for the subject land, and within fifty (50) feet or one property owner deep of the proposed project, whichever is less;
 16. Existing and proposed water mains, storm sewers, sanitary sewers, culverts, bridges, and other utility structures or facilities within, adjacent to, or serving the subject land, including pipe sizes, grades, and exact locations, as can best be obtained from public or private records;
 17. Existing zoning of the land and all adjacent lands;
 18. Existing and proposed contours based on United States Geological Survey (USGS) datum with intervals of not more than five (5) feet where the slope is greater than ten percent (10%) and not more than two (2) feet where the slope is less than ten percent (10%). Elevations shall be based on sea level datum;
 19. The water elevation at the date of the survey of lakes, streams, or swamps within the project affecting it, as well as the approximate high and low water elevation of such lakes, streams, or swamps. The plan shall also show the contour line of the regulatory flood (100-year flood) elevation. All elevations shall be based on sea level datum;
 20. A statement of the proposed uses, stating the type and size of buildings, and the type of business, commercial or industry, so as to reveal the effect of the project on traffic, fire hazards, or congestion of population;
 21. Statement of proposed starting and completion dates for the project, including any proposed phasing and sequencing;
 22. Radii, internal angles, points of curvature, tangent bearings and lengths of all arcs, chords and chord bearings;
 23. Accurate location of all survey monuments erected, corners, and other points established in the field in their proper places; and
 24. Supplementary explanation of the specific type(s) of activities proposed on the site. Such information shall include, but is not limited to:
 - a. Estimated number of employees, resident shoppers, residents, etc;
 - b. Hours of operation;

- c. Any changes anticipated in terms of dust, odor, smoke, fumes, noise, light, hazardous or noxious fumes, wellhead protection, etc;
 - d. Modifications to vegetative cover, drainage patterns, earth work, problem areas;
 - e. Any ancillary improvements that the applicant proposed to remedy or prevent problems created by the development; and
 - f. Draft version of any design guidelines, if applicable.
- E. Landscaping shall be in accordance with the requirements in Chapter 9, Landscaping Standards.
- F. Other information that may reasonably be required by the Executive Director to adequately assess the proposal which may include:
- 1. A report examining the estimated impacts of the proposed development on the school district or a letter from the school district outlining its estimates of the impacts of the proposed development;
 - 2. Estimated impacts on and capabilities of emergency services, including but not limited to, fire, police and emergency medical services, and their respective response time;
 - 3. An examination of the impacts of the proposed development on available recreational facilities, as well as any proposed mitigation measures;
 - 4. An examination of impacts to utilities servicing the facilities, such as water, sewer, gas, electrical, communication, and other utilities.
 - 5. A report examining the fiscal impacts of the project, both positive and negative.
 - 6. A traffic study examining the impacts of development of the highest acceptable use, as well as any new roads/intersections on current and projected traffic flow and level-of-service.
 - 7. IDEM permit application materials.

12.13.6 Administrative procedures

- A. Applications
- Applications shall be filed with the Staff in conformance with the regulations set forth in this Chapter.
- B. Special requests
- In addition to the minimum data and information required by this Section, every applicant shall submit such other additional data, information, or documentation as the Executive Director or any body before which its application is pending may deem necessary or appropriate to achieve a full and proper consideration of that application.
- C. Supplemental data

Whenever supplemental data in connection with a previously filed application is required by the County or offered by the applicant, it shall be submitted as prescribed by the Calendar of Meetings and Filing Dates. The filing of such data shall, at the discretion of the Executive Director and of the body hearing the application, be cause to delay a requested or scheduled hearing or decision date.

D. Fees

Every application must be accompanied by a fee, as prescribed by the Official Fee Schedule.

12.13.7 Notice

To be provided in accordance with this Chapter.

12.13.8 Action on site development plans

If the site development plan meets all the requirements of this Chapter, the application shall be approved.

If the development plan does not meet all the requirements of this Chapter, the County's Zoning Ordinance, Subdivision Ordinance, other applicable County Ordinances and special items raised during the review of the application, the application may be denied.

If minor corrections to the site development plan are necessary for it to meet the standards set for approval, and such minor corrections can be clearly noted, then such conditions may be noted and approval of the application may be given. Revised drawings shall be submitted to the Executive Director prior to issuance of an Improvement Location Permit.

If the Area Plan Commission finds the site development plan to be incomplete with respect to necessary information, the Area Plan Commission may continue action on the site development plan until the required additional information is provided.

12.13.9 Standards for site development plan review

In reviewing and determining whether to approve or disapprove a site development plan, the Executive Director shall consider any of the following criteria applicable to development of the site:

- A. The application shall comply with the provisions of the White County Zoning Ordinance and other ordinances of the County.
- B. The plan shall be in reasonable conformity with the Comprehensive Plan.
- C. Reasonable provision shall be made to ensure that development will be served by essential public facilities and services such as highways, streets, parking spaces, police and fire protection, drainage structures, refuse disposal, water, sewers or septic, and schools.
- D. Any building or structure shall be reasonably accessible to fire, police, emergency and service vehicles. When deemed necessary for access, emergency vehicle easements shall be provided. The access for fire, police and emergency vehicles shall be unobstructed at all times.

- E. Adequate provision shall be made to ensure the compatibility of the proposed development, including mass, scale, site layout, and site design with the character of the surrounding property and the neighborhood, including:
 - 1. Relationships of buildings to sites
 - a. The site shall be planned to achieve a desirable transition to the street, provide for adequate planting, safe pedestrian movement and off-street parking areas.
 - b. Parking areas should include innovative ways to significantly screen the parking areas from views from public ways in accordance with Chapter 9, Landscaping Standards.
 - c. Without restricting the permissible limits of the applicable zoning district, the height and scale of each building shall be compatible with its site and existing (or anticipated) adjoining buildings.
 - 2. Signs
 - a. All signs shall be in conformance with the provisions of Chapter 10, Sign Standards.
- F. Open space provided is configured to make that open space usable, functional, and appropriate to the development proposed.
- G. Streets and sidewalks shall, insofar as reasonably practical, provide access and good traffic circulation to and from adjacent lands, existing streets and sidewalks.
- H. Provision shall be made to ensure that adequate access roads or entrance or exit drives will be provided and will be designed and improved so as to prevent traffic hazards or problems and to minimize traffic congestion in public streets.
- I. Adequate provision shall be made to ensure that the vehicular circulation elements of the proposed development will not create hazards to the safety of vehicular or pedestrian traffic on or off the site, disjointed vehicular or pedestrian circulation paths on or off the site, or undue interference and inconvenience to vehicular and pedestrian travel.
- J. Adequate water mains and fire hydrants shall be provided in accessible places in accordance with good fire fighting and fire prevention practice.
- K. Adequate provision shall be made for the collection and disposition of all on- and off-site storm water and natural water, including but not limited to on-site drainage retention facilities.
- L. Adequate provision shall be made for the collection and disposition of sanitary sewage.
- M. Adequate provision shall be made to avoid an increase in hazard to adjacent property from flood, increased run-off or water damage.
- N. Adequate provision shall be made to avoid glare of vehicular and stationary lights that would affect the established character of the neighborhood, and to the extent

such lights will be visible across from any property line, the performance standards for illumination shall be met.

- O. Adequate provision shall be made to ensure that the location, lighting and type of signs and the relationship of signs to traffic-control is appropriate for the site and will not have an adverse affect on any adjacent properties.

12.13.10 Conditions on plans

In considering any site development plan, the Area Plan Commission and/or Executive Director may establish reasonable and appropriate conditions upon the approval of a site development plan.

12.13.11 Public improvement performance guarantees

To ensure compliance with any condition(s) imposed under this Chapter, the Area Plan Commission may require that a cash, certified check, irrevocable bank letter of credit, or surety bond acceptable to the County, equaling one hundred ten (110) percent of the estimated cost of completion of the required public improvements, be deposited with the County to ensure faithful completion of the improvements and also be subject to the following:

- A. The performance guarantee shall be deposited prior to the onset of any construction, clearing of land or earth moving related to the site development plan. The County may establish procedures whereby a rebate of any cash deposits in reasonable proportion to the ratio of work completed on the required improvements will be made as work progresses. Any partial release of funds shall be less than ten (10) percent which shall be retained by the County until all work has been completed and subsequently inspected and approved by the County or its agents. This does not relieve the applicant from satisfying all applicable maintenance warranties and/or guarantees necessary to ensure the proper functioning of said public improvements.
- B. For the purposes of administering and enforcing this Section, "improvements" shall mean those features and actions associated with a project which are considered necessary by the County Commissioners, to protect natural resources, or the health, safety, and welfare of the residents of the County and future users or inhabitants of the proposed project or project area, including roadways, lighting, utilities, sidewalks, screening, landscaping, and surface drainage. Improvements do not include the entire project, which is the subject of development plan approval.

12.14 WRITTEN COMMITMENTS

12.14.1 Purpose, intent, and authority

1. This Section grants authority to the Area Plan Commission and the Area Board of Zoning Appeals to allow or require specific development commitments in compliance with IC 36-7-4-1015. .

12.14.2 Commitments for rezoning or PUD proposal

- A. The Area Plan Commission may require or allow a written commitment either for a proposal for a zoning map change or proposal for a PUD district ordinance, or for both of these proposals, to the extent allowed by applicable law.
- B. If the appropriate legislative body adopts (as certified) the proposal for PUD district ordinance for which the Area Plan Commission required or allowed the written commitment, then the owner of the parcel shall record or cause the commitment to be recorded before the rezoning or PUD district ordinance can become effective.
- C. Once the commitment is recorded, the commitment may be modified or terminated only by a decision of the Area Plan Commission made at a public hearing after notice as provided by this Chapter. The request for modification or termination may be initiated by the property owner or by the Area Plan Commission. The Area Plan Commission may approve or disapprove modification or termination to the extent allowed by applicable law. However, pursuant to IC 36-7-4-615(b) as amended, a commitment required or allowed for a rezoning or PUD district ordinance terminates if the zoning for the parcel changes in the future.
- D. The enforcement provisions set forth in Chapter 13, Enforcement, apply to commitments for proposals for zoning map change and PUD district ordinances.
- E. The form of commitments for proposals for zoning map change and PUD district ordinances shall be as determined by the Area Plan Commission.

12.14.3 Standard forms

- A. The Area Plan Commission may adopt written commitment forms as the standard forms for written commitments which are permitted or required by the Area Plan Commission, including written commitments for site development plans, zoning map changes, and PUD district ordinances.
- B. The Board of Zoning Appeals may adopt written commitment forms as the standard forms for written commitments, which are permitted or required by the Board of Zoning Appeals.
- C. If adopted, the appropriate standard form shall be used whenever a written commitment is permitted or required by the Area Plan Commission or Area Board of Zoning Appeals. When necessary, the standard forms may be modified in order to form the type of commitment needed and not already provided for in one of the standard forms. However, the basis of the standard forms shall be used, with the content modified only as needed to conform to the type of commitment permitted or required. An otherwise modified form may be rejected by a majority vote of the Area Plan Commission or Board of Zoning Appeals (whichever body permitted or required the commitment).

12.14.4 Binding effect

- A. Unless modified or terminated as described in this Chapter, a written commitment that is permitted or required by the Area Plan Commission or Area Board of Zoning Appeals and recorded is binding on:

1. The owner of the parcel;
 2. A subsequent owner of the parcel; and
 3. A person who acquires an interest in the parcel.
- B. A written commitment that is permitted or required by the Area Plan Commission or Board of Zoning Appeals is binding on the owner of the parcel even if the commitment is unrecorded. However, an unrecorded commitment is binding on a subsequent owner or other person acquiring an interest in the parcel only if that subsequent owner or other person has actual notice of the commitment.

12.14.5 Effective date of commitment

- A. A written commitment permitted or required by the Area Plan Commission in connection with a site development plan or a written commitment permitted or required by the Board of Zoning Appeals shall take effect upon the approval of the site development plan, special exception use, or zoning variance related to the commitment.
- B. A written commitment for a zoning map change or a Planned Unit Development shall take effect upon the later of the adoption of the rezoning or Planned Unit Development or the recording of the commitment. However, the rezoning ordinance will not become effective until the commitment has been recorded and all necessary legal requirements have been met.

12.14.6 Covenant running with the land

A written commitment that is permitted or required by the Area Plan Commission or Board of Zoning Appeals shall be considered a covenant running with the land and shall bind all subsequent owners to its terms and conditions and any subsequent modification thereto made pursuant to this instrument, statutes of the State of Indiana, or ordinance of White County.

12.14.7 Enforcement

Written Commitments permitted or required by the Area Plan Commission or Board of Zoning Appeals may be enforced jointly and severally by:

- A. The Area Plan Commission or Board of Zoning Appeals (whichever body permitted or required the commitment); and
- B. All persons with a legal interest in the property to be rezoned and all persons with real property abutting the property subject to a rezoning petition, all owners of real property adjacent to property or adjoining to property, are interested parties. The identity of such owners shall be determined from the records of the Office of the White County Auditor which list the current owners of record. For purposes of this paragraph, the cutoff date for such determinations shall be 12:00 noon on the date of filing for enforcement.

12.14.8 Recording

- A. Commitments shall be signed by the Executive Director, and shall be recorded in the office of the White County Recorder.

- B. The Area Plan Commission or Board of Zoning Appeals shall require the owner of the parcel given a written commitment to either record the commitment or authorize White County to record the commitment at the owner's expense.
- C. Commitments in connection with site development plans, special exception uses, or variances shall be recorded upon the granting of the approval. Commitments in connection with zoning map changes or Planned Unit Development shall be recorded as soon as possible after such approval by the appropriate legislative body of the rezoning or Planned Unit Development. Such development will not take effect until the commitment has been recorded.

12.14.9 Modification and termination

A written commitment that is permitted or required by the Area Plan Commission or Board of Zoning Appeals may be modified or terminated only by a decision of the Area Plan Commission or Board of Zoning Appeals (whichever body permitted or required the commitment) made at a public hearing after notice as provided by this Chapter. The request for modification or termination may be initiated by the property owner or by the body that permitted or required the commitment. The body that permitted or required the commitment may approve or disapprove modification or termination to the extent allowed by applicable law. However, pursuant to IC 36-7-4-1015 (4) as amended, a commitment may provide terms providing for its own expiration and/or terms for automatic termination.

12.14.10 Public notice

When the Area Plan Commission or Board of Zoning Appeals is going to consider modification or termination of an existing written commitment, notice of a public hearing shall be given in allowance to the requirements of this Chapter.

12.14.11 Validity of other land use restrictions

This Chapter does not affect the validity of any covenant, easement, equitable servitude, or other land use restriction created in accordance with law.

12.15 ZONING HEARING OFFICER AND ALTERNATE PROCEDURE

This section, established by the Area Plan Commission, provides for an Alternate Procedure by which a Development Standards Variance or Special Exception Use Permit may be approved

12.15.1 Authorization of the Area Plan Hearing Officer

There is hereby established by the Area Plan Commission, the position of Area Plan Hearing Officer, who shall have such powers and duties as are prescribed in the following section and by rule duly adopted by the Area Plan Commission.

12.15.2 Recommendation of the Area Plan Hearing Officer and Alternate

Recommendation for the assignment of the person to serve as the Area Plan Hearing Officer or Alternate, along with recommendation to remove such person, shall be by the Area Plan Commission. The Area Plan Commission may recommend approval, removal

or replacement of any Area Plan Hearing Officer or Alternate at any time, with or without cause.

12.15.3 Approval of the Area Plan Hearing Officer and Alternate Recommendations

Approval of all recommendations addressed in Section 12.16.2 of this Ordinance shall require approval by the White County Commissioners to become effective.

12.15.4 Powers and Duties of Zoning Hearing Officer

The Area Plan Hearing Officer shall have the same powers and duties as the Board of Zoning Appeals to approve or deny applications through the Alternate Procedure.

12.15.5 Alternate Procedure

The Area Plan Commission shall, by rule duly adopted;

- A. Establish the circumstances, if any, in which it would be appropriate for the Area Plan Hearing Officer to hear or transfer proceedings for applications submitted for Development Standards Variance or Special Exception Use Permits.
- B. Designate requirements for the conduct of proceedings before the Area Plan Hearing Officer including, but not limited to, the creation and filing of minutes and records, regulation of conflicts of interest and criteria for segregating applications between the Area Plan Hearing Officer and the Board of Zoning Appeals.

12.16 ADDRESSING, ROAD/STREET/ALLEY NAMING & BRIDGE DEDICATIONS

12.16.1 Purpose and Intent

The purpose of this Chapter is to establish uniform standards for house and building numbering in White County, Indiana and establish processes for naming or renaming roads/streets/alleys and dedicating bridges within White County. It is intended to provide continuity, avoid duplication and prevent general confusion regarding the location of developed parcels of land within the county.

12.16.2 Applicability

Unless otherwise stated, this Chapter shall apply to all roads and streets within White County with the exception of Interstate highways and portions of US Highways and State Roads outside of Municipality Corporation Limits. Addressing requirements apply to all structures as defined in Subsection 12.17.6 of this Chapter.

12.16.3 Definitions

For the purposes of this Chapter, the following definitions shall apply. Any other terminology utilized herein shall revert to common Area Plan definition procedures.

- A. Base Lines – Existing recognizable lines which divide the county into quadrants or sectors. The intersection of base lines establishes the starting point for the numbering system.

- B. Block Interval – The hundred number interval is the distance between grid lines, or the point where the next highest block number designation is used.
- C. Customer (Addressee) – A family, individual, residence, business or industry.
- D. Frontage Interval – The distance in foot frontage along a street, highway or county road which is used to assign consecutive property numbers, beginning from the nearest grid or base line. The address system used by White County assumes a frontage interval of five and twenty-eight hundredths (5.28) feet.
- E. Grid Lines – Imaginary lines or actual county roads which are located a specific distance from and perpendicular or parallel to base lines. These lines indicate the point where block numbers change from one hundred to the next higher hundred. Grid lines are used to standardize the numbering of parallel blocks at the same distance from the base lines.
- F. Primary Address Number (City-type Address) – The numeric or alphanumeric component of a city-type address which precedes the street name.
- G. Structure – A residential home, apartment building, business or commercial building, industrial or manufacturing building, town home, condominium, wind turbine, communications tower, meteorological tower, publicly owned building, or other similar improvement which fronts onto a public or private street or road or is accessed via an easement.

12.16.4 Ordinance Repeal

White County Ordinance #COMM-91-12-16, Road Numbering and Naming in White County and Ordinance Amendment #05-10-03-02 Road Numbering and Naming in White County are repealed by this Ordinance.

12.16.5 Bridge Dedications

Any bridge located within White County may be dedicated by:

- A. Submitting, in writing, the proposed name of dedication to the Staff for review. The Staff shall approve or deny the request. The Staff shall deny the request only under the condition that the name can be confused with a street, community or other dedicated location.

Upon approval, the request will be forwarded to the appropriate legislative body for final approval or denial.

12.16.6 Addressing

This Section provides the street numbering system in order to provide an exact geographic location for all structures in the County.

- A. Assignment Authority
 - 1. The Staff shall serve as the coordinating body in White County with the responsibility for assigning street addresses within the jurisdiction of the White County Area Plan Commission. The Staff shall coordinate its addressing efforts with the White County E 9-1-1 Communications Director, local Postmasters and large mailers into the county such as utilities and government.

2. Staff shall send out address assignments or address changes on the first business day of each month to all parties listed above.

B. The Grid Coordinate System

For White County, the naming of the road system and the issuance of structure addresses is based on the Lyman/Purdue Street Numbering System. The system is better known as the Grid Coordinate System. The system utilizes two base lines which run at approximate right angles to each other to divide the county into quadrants. Most of the county roads are numbered based on their distance from the north-south or east-west base lines. The center point of the county is at the intersection of Main Street and Logan Street in Reynolds. The north-south and the east-west section lines from that point are the established base lines from which all county addresses originate (excluding municipality addresses which shall be established from a center point within the municipality).

C. Measurements

All address measurements will be taken from the middle of an intersection.

D. Assignment of Official, Permanent Property Addresses

1. Structures located in White County shall be assigned a permanent city-type street address. Structures located on the south side of an east-west street/road and those located on the west side of a north-south street/road shall have an even numbered property address. Structures located on the north side of an east-west street/road and those located on the east side of a north-south street/road shall have an odd number. Municipalities in which addressing was originally set up in reverse, shall have addresses assigned in the manner in which they were originally set up.
2. When possible, a structure shall be addressed to the street/road in which the front entrance faces.

E. Determining a Property Address

1. Rural Addresses

An official street address shall contain no more than five digits with the first digit, or the first two digits if the structure is located ten (10) or more miles from the baseline, indicating the miles from the relative base line. The last three digits indicate the additional distance in thousandths of a mile to the structure or entry to the structure from the relative baseline. A rural address of less than four digits indicates the structure or entrance to the structure is less than one mile from the relative baseline. In the case of most rural addresses, the address should be assigned from where the entry to the structure meets the road as this is how the Emergency 9-1-1 service will locate the property in the most expedient manner, which is the main focus of the address assignment.

2. Municipality Addresses

An official street address is established by the system set up within each municipality with the first digit of a three-digit address and the first two digits in a four digit address indicating the number of blocks from the relative baseline.

3. Diagonal Street Addresses

Addresses on diagonal streets shall be assigned in the general direction in which the street runs.

4. Loops & Circles

Loop addresses shall be assigned as any other street address with the exception that the numbers will run consecutively from one end of the loop to the other with no regard to the rounded part of the loop that runs in an opposite direction. If the outside numbering of the loop is odd numbers, the inside of the loop will be even numbers and vice versa. Loop addressing will not follow the general north/east odd numbers and south/west even numbers. A Circle begins and ends on the same street with consecutive odd numbering on the outside of the circle and consecutive even numbering on the inside as described in the American Planning Association Report No. 332 Planning Advisory Service "Street-Naming and Property-Numbering Systems" by Margaret A. Corwin.

F. Placement and Size of Address Numbers

1. Once a property address has been assigned to a specific structure, it shall be the responsibility of the property owner or resident to provide the address number on the structure and the mailbox or mailbox post in rural areas.
2. Numerical components are to be placed on structures in a location which faces or is visible from the street upon which it is addressed except where the entrance does not front a street or road, then the structure shall be addressed in reference to its location as to a street or road or by a sign visible from the road.
3. Numerical components shall be a minimum of one (1) inch in height on a mailbox or mailbox post and minimum of two (2) inches in height on a structure or sign.
4. The numerical components placed upon a structure should be placed near a main entry door or on a cornice, porch, etc., located above the main entry door. The numbers should be located at least five (5) feet above the threshold near the entrance door. Numerical components on the structure shall contrast in color with the background of the structure upon which they are posted.
5. Numerical components placed on the mailbox or mailbox post must be located so as to face the postal carrier route. Numbers and lettering may be placed on both sides of the mailbox or mailbox post if so desired by the property owner or resident.

Street address numbers and lettering must be placed in a visible location on all structures by January 1, 1992 or, in cases of structures built after January 1, 1992, prior to issuance of an occupancy permit.

12.16.7 Street/Road/Alley Name Assignments or Changes

For purposes of this Section, when the term "street" is used, it shall include road and alley.

- A. Original Street Name Assignments for Public Streets to lie within a Subdivision.

1. All street names to lie within a platted, recorded subdivision shall be assigned as required by the White County Indiana Subdivision Control Ordinance.
- B. Street Name Assignments for Public Streets outside a Recorded Subdivision.
1. Naming of new streets or existing streets without names
 - a. Petitioner shall submit in writing a name or list of names and their location as shown on the White County GIS mapping system to the Staff. The maps shall show the full extent of the proposed or existing street area. Multiple maps should be submitted if required.
 - b. There shall be no re-use of former or discontinued street names. With the exception of street extensions, there shall be no duplication of street names by sound or spelling. No street name shall duplicate or too closely resemble, phonetically or in spelling, the name of any existing street anywhere else within the jurisdiction of the White County Area Plan Commission. Differentiation shall not be by the addition of suffixes such as road, street, land, trail, way or any other such suffix.
 - c. Staff shall check proposed names and certify the names submitted as acceptable or not acceptable according to the rules of this Chapter. The Staff shall check for duplicates, previously rejected names, names reserved for subdivisions not yet completed and phonemes.
 - d. Staff shall submit the proposed name to the United States Postal Service, Emergency 9-1-1 and the Monticello Fire Department for approval. Each Agency shall provide an opinion of acceptability to the Staff which shall be provided to the determining authority.
 - e. In the event that the proposed street name is acceptable to all parties, the Staff shall prepare a verified petition and submit such petition to the appropriate legislative body for consideration at the body's public meeting for adoption. If the street being named is both in a municipality and outside the municipality, the petition will be submitted to the legislative body wherein the majority of the street lies.
- C. Renaming of Streets
1. A petitioner desiring to have a street renamed shall provide a written justification for the request (maximum 300 words) including the reason or reasons for the request.
 2. The petitioner shall submit in writing a proposed name or list of names including cross reference to the street's current name.
 3. The renaming of streets shall be subject to the same standards as the naming of new streets. In addition, the petitioner shall provide the Staff with the following:
 - a. A map showing the entire street in question, including the names and complete address of each property owner abutting the street petitioned to be changed. Vacant lots shall be identified as such on the map.

- b. A second map shall show all alleys, and streets within one quarter (1/4) mile of any portion of the street petitioned to be changed.
- c. A petition calling out the existing street name and the signatures of all parties as identified above, or an affidavit authorizing an agent to act on behalf of said parties, signifying their agreement with the proposed name change.
- d. Any additional information reasonably required by the Staff.
- e. Any applicable fee as prescribed by the Official Fee Schedule.

D. Private Streets

Private streets may be named or renamed by the Staff. Private streets shall be subject to the same street name standards as spelled out in Section 12.17.7 B 1b and Section 12.17.7 B 1c of this Ordinance.

CHAPTER 13 ENFORCEMENT

13.0 GENERAL PROVISIONS

13.0.1 Authority

The Executive Director is hereby designated to enforce the terms and provisions of the Zoning and Subdivision Control Ordinances, herein after referred to as “the Ordinances” in this Chapter, in accordance with the provisions of this Chapter. For purposes of this Chapter, the term “Executive Director” shall also refer to his/her authorized designee.

13.0.2 County

The County, by its authorized official, may, by suit in the Circuit or Superior Court(s) of White County, enjoin violations of the Ordinances.

13.0.3 Area Plan Commission

The Area Plan Commission by and through its duly authorized agent may, by suit in the Circuit or Superior Court(s) of White County seek to enjoin violations of the Ordinances.

13.0.4 Persons Liable

Any structure, land, building, or premises used in violation of this Ordinance shall constitute a civil zoning violation. The owner, possessor, tenant, occupant or contract vendee of any structure, land, building, or part thereof who keeps, maintains, creates, causes, assists, directs, or participates in any use or situation thereon that is contrary to the requirements of the Ordinances shall be responsible and liable for the violation and all penalties, fines or other damages connected with or caused by the violation.

13.0.5 Right of Entry

The Executive Director may enter upon any premises at any reasonable time to make inspections of all buildings, structures, and premises located within the jurisdiction of the Ordinances to determine their compliance with the Ordinances. Upon entry, the Executive Director shall furnish sufficient identification and information advising the owner, tenant, or occupant that the Executive Director is a representative of White County and the reason for the inspection. If the Executive Director is denied access to or entry upon the premises, the Area Plan Commission by and through its duly authorized agent may apply to any court of competent jurisdiction for permission for the Executive Director to access and enter the premises.

13.0.6 Stop Work Order

The Executive Director and The Area Plan Commission, by and through its duly authorized agent, are empowered to issue a stop work order and/or revoke an Improvement Location Permit requiring the suspension of land improvement of any kind, if, and in the event that, any of the following circumstances exist:

- A. A site is being improved without an Improvement Location Permit or any other permit required by the Ordinances; and/or
- B. A site is being improved in violation of:

1. The terms, conditions, or provisions of the Ordinances;
2. The terms, provisions, conditions, or commitments of a variance;
3. The terms, provisions, conditions, or commitments of a special exception use permit;
4. The terms, provisions, or commitments of a Planned Unit Development plan;
5. A commitment made in connection with a petition for a zone map amendment; and/or
6. Any other development approval granted under the Ordinances.

The stop work order shall be posted in a conspicuous place on the property on which the violation is located or occurring, or personally delivered to the owner, occupant, tenant, or person in charge of the property.

The Area Plan Commission, by and through its duly authorized agent, may bring a cause of action in a court of competent jurisdiction in White County, Indiana to enforce the provisions of a stop work order.

Remediation

The Executive Director shall determine whether a violation has been properly remediated. If the Executive Director determines it appropriate or necessary, he/she shall determine a dead line for remediation completion. If the Executive Director determines it is desirable for achieving compliance to the Ordinances, he/she may provide remediation alternative(s) to a violator.

13.1 CIVIL ZONING VIOLATIONS

13.1.1 Enforcement Procedures

Nothing in this Chapter precludes the Executive Director from making contact in verbal, written or electronic format, with any person in violation or potentially in violation of the Ordinances prior to the issuance of a warning ticket or citation.

13.1.2 Enforcement Without Prior Notice

Prior enforcement notice is not required where a violation is determined by the Executive Director to be a threat to public health or safety or where elsewhere provided in the Ordinances, the Area Plan Commission, by or through its duly authorized agent, may seek abatement or cessation of the violation by invoking any penalties or remedies authorized by the Ordinances or by law.

13.1.3 Warning Ticket

- A. Any person who violates the Ordinances shall be deemed to have committed a civil zoning violation. Upon a finding by the Executive Director that a person has committed a civil zoning violation, the Executive Director shall issue a written warning ticket to, but in no way limited to, the legal owner, tenant, contract vendee, or any person or entity with a possessory interest in the property upon which the violation occurs.
- B. The warning ticket shall be served by personal service, by certified mail, or by placement in a conspicuous place on the property where the violation occurs and shall serve as notice of the civil zoning violation. The warning ticket shall be in the form prescribed by the Executive Director

- C. Unless otherwise provided in the warning ticket, the violator shall have thirty (30) days to abate the violation.
- D. A person who receives a warning ticket may:
 - 1. Correct the violation;
 - 2. File a petition for a variance, special exception use, or rezone;
 - 3. Negotiate an acceptable compliance plan with the Executive Director;
 - 4. Utilize other means provided by the Ordinances to correct the violation.
- E. The Executive Director's finding of a violation of the Ordinances may be appealed to the Area Board of Zoning Appeals by the filing of a proper application which meets the requirements of Section 12.6.4 of the Zoning Ordinance with the Area Plan Office within thirty (30) days from the date the warning ticket was issued. Upon receipt of a completed application and all other required information and documents, the Staff will schedule the appeal for the next applicable meeting of the Area Board of Zoning Appeals. The Staff will provide the Board with all of the necessary documentation creating the record of appeal.
- F. If the Area Board of Zoning Appeals upholds the Executive Director's finding of a violation, the violator may file for Judicial Review as provided for in the 1600 Series of IC 36-7-4 as amended from time to time. A person must have standing to submit a petition for judicial review of a zoning decision of the Area Board of Zoning Appeals to the appropriate court. The petition shall be presented to the court not later than thirty (30) days after the date of the zoning decision that is the subject of the petition for judicial review. A person who fails to timely object to a zoning decision or timely petition for review a zoning decision within the thirty (30) day period prescribed in this section waives the right to judicial review under this subsection. For purposes of this subsection, the following is applied:
 - 1. "Standing" is determined as provided for in IC 36-7-4-1603 of the 1600 Series as amended from time to time.
 - 2. "Zoning Decision" is defined in IC 36-7-4-1016 of the 1000 Series as amended from time to time.A person may file a petition for judicial review under this section only after exhausting all administrative remedies available within the Area Board of Zoning Appeals.
- G. The Executive Director's finding of a violation of the Ordinances may only be appealed one time to the Area Board of Zoning Appeals. Such appeal shall be made before a citation is issued for the violation.

13.1.4 Citations

- A. In the event that a person fails to act in the time stipulated upon the warning ticket issued under section 13.1.2, the Executive Director may issue a citation for the continuing civil zoning violation and assess a fine according to the Fine Schedule.
- B. For the purposes of this Chapter, the term "Fine Schedule" shall mean the Fine Schedule for civil zoning violations, officially adopted by the White County Board of

Commissioners. The citation shall be in the form prescribed by the Executive Director.

- C. Once a citation is issued, each day a violation remains uncorrected shall be considered a distinct and separate civil zoning violation, and may be subject to a daily fine in an amount prescribed by the Fine Schedule and indicated in the respective citation or fine assessment notice.
- D. All fines shall be paid to the Area Plan Office within thirty (30) days from the date the citation was issued or within a time frame and schedule as agreed to by the Executive Director. The Staff shall render to the person making the payment a receipt stating the amount and purpose for which the fine has been paid and a duplicate of which shall be made a part of the records of the Area Plan Office.
- E. A person who receives a citation may elect to abate the violation and pay the assessed fine, negotiate an acceptable settlement and compliance plan with the Executive Director or appeal the amount of the fine in accordance with Section 13.1.5 of this Chapter within thirty (30) days from the date the citation was issued. Any additional monetary fine, as prescribed by the Fine Schedule, shall be stayed upon application for appeal. Upon receipt of an application to appeal the fine, the person will be scheduled to be heard by The Area Board of Zoning Appeals at the next applicable meeting. The person will be notified by mail of the time, date and location of the scheduled meeting. The Area Plan Staff will provide the Board with all of the necessary documentation creating the record of the appeal.
- F. The Area Board of Zoning Appeals' decision regarding the amount of the fine assessed may be appealed by filing for Judicial Review as provided for in the 1600 Series of IC 36-7-4 as amended from time to time. A person must have standing to submit a petition for judicial review of a zoning decision of the Area Board of Zoning Appeals to the appropriate court. The petition shall be presented to the court not later than thirty (30) days after the date of the zoning decision that is the subject of the petition for judicial review. A person who fails to timely object to a zoning decision or timely petition for review a zoning decision within the thirty (30) day period prescribed in this section waives the right to Judicial Review under this subsection. For purposes of this subsection, the following is applied:
 - 1. "Standing" is determined as provided for in IC 36-7-4-1603 of the 1600 Series as amended from time to time.
 - 2. "Zoning Decision" is defined in IC 36-7-4-1016 of the 1000 Series as amended from time to time.A person may file a petition for Judicial Review under this section only after exhausting all administrative remedies available within the Area Board of Zoning Appeals.
- G. If a person fails to pay the assessed fine as required, the Area Plan Commission or Executive Director on behalf of the Area Plan Commission, may authorize the Area Plan Commission Attorney to file a civil lawsuit or to pursue any other remedy available under the law.
- H. A person adjudged to have committed a zoning violation is liable to the Area Plan Commission for court costs and attorney fees incurred in connection with enforcing the Ordinances and collecting assessed fines.

- I. Seeking a civil penalty as authorized by this Chapter shall not preclude the Area Plan Commission, or Executive Director, on behalf of the Area Plan Commission, from seeking alternative relief from the court in the same action, or from seeking injunctive relief or other remedy in a separate action for the enforcement of the Ordinances.
- J. A change of venue from White County shall not be granted in such a case, as provided in Indiana Code 36-7-4-1014, as amended from time to time.

13.1.5 Appeals

A. General Provisions

1. A person who receives a warning ticket, a citation or a fine assessment may choose to file an appeal to the Area Board of Zoning Appeals in accordance with the procedures set out in this section. In addition to the requirements of this Section, all appeals must be filed in compliance with Section 12.6.4 of the Zoning Ordinance.
2. An appeal of the Executive Director's issuance of a warning ticket and determination that a violation exists, may only be appealed one time to the Area Board of Zoning Appeals. Such appeal shall be made before a citation is issued for the violation.
3. An appeal of a fine and late fees issued by the Executive Director may only be appealed one time to the Area Board of Zoning Appeals. Such appeal shall be made within thirty (30) days from the date of the initial fine issuance. Any additional monetary fine, as prescribed by the Fine Schedule, shall be stayed upon the filing of an appeal.
4. A person who files the appeal within the time period set forth above shall pursue the petition in an expeditious fashion.
5. Upon receipt of a completed application and all other required information, documents and filing fees, the Area Plan Staff will schedule the appeal for the next applicable meeting of the Area Board of Zoning Appeals.
6. The Area Plan Office will provide the Board with all of the necessary documentation creating the record of the appeal.
7. Any person aggrieved by a decision of the Board may file for judicial review as provided for in the 1600 Series of IC 36-7-4 as amended from time to time. A person must have standing to submit a petition for judicial review of a zoning decision of the Area Board of Zoning Appeals to the appropriate court. The petition shall be presented to the court not later than thirty (30) days after the date of the zoning decision that is the subject of the petition for judicial review. A person who fails to timely object to a zoning decision or timely petition for review a zoning decision within the thirty (30) day period prescribed in this section waives the right to judicial review under this subsection. For purposes of this subsection, the following is applied:
 - a. "Standing" is determined as provided for in IC 36-7-4-1603 of the 1600 Series as amended from time to time.
 - b. "Zoning Decision" is defined in IC 36-7-4-1016 of the 1000 Series as amended from time to time.

8. A person may file a petition for Judicial Review under this section only after exhausting all administrative remedies available within the Area Board of Zoning Appeals.
- B. The violator may appeal the finding of a violation by the Executive Director.
1. If the Board denies the Executive Director's finding of a violation, all enforcement action(s) related to the appeal shall be dismissed.
 2. If the Board upholds the Executive Director's finding of a violation, the enforcement process moves forward.
 3. The violator may file for a Judicial Review of the Area Board of Zoning Appeals' decision as provided for in this Chapter. The filing must be filed within thirty (30) days of the Area Board of Zoning Appeals' decision.
 4. The violator may appeal the fine assessed by the Executive Director;
 5. The Board may determine the fines assessment is appropriate and leave stand;
 6. The Board may reduce the fine assessment if it sees fit;
 7. The Board may increase the fine assessment if it sees fit.
- C. Upon receipt of a completed application and all other required information and documents, the Staff will schedule the appeal for the next applicable meeting of the Area Board of Zoning Appeals.
- D. Staff will provide the Board with all of the necessary documentation creating the record of the appeal.
- E. If the Board upholds the determination of a violation(s) of the Ordinances which led to issuance of the warning ticket or citation, and the civil zoning violation continues at the real estate, then the warning ticket or citation will move forward as required in 13.1.1 or 13.1.2, whichever applies. The applicant can conform to the Ordinances, correct the violation and pay the fine(s), file for Judicial Review or request a trial on the citation for determination by a court of competent jurisdiction in White County, Indiana.

13.1.6 Trial

- A. Upon receipt by the Staff of the notice of intention to stand trial, a lawsuit will be commenced by the Area Plan Commission Attorney in a White County, Indiana court. The matter shall be scheduled for trial, and a Summons and Order to Appear shall be served upon the Defendant.
- B. If a person who receives a citation fails to pay the assessed fine within the time limit as established by the citation and/or fails to correct or abate the citation, the Area Plan Commission or Executive Director may direct the Area Plan Commission Attorney to file a civil lawsuit as prescribed by applicable laws and ordinances, and seek penalties as prescribed in this Chapter or by law.
- C. A person adjudged to have committed a zoning violation is liable for the court costs and fees. No costs shall be assessed against the enforcement agency in any such action.

- D. In proceedings before the court for a zoning violation, the Indiana Rules of Trial Procedure shall govern. The designated enforcement entity has the burden of proving the civil zoning violation by a preponderance of the evidence.
- E. Seeking a civil penalty as authorized by this section does not preclude the County or Area Plan Commission from seeking alternative relief from the court in the same action, or from seeking injunctive relief or other remedy in a separate action for the enforcement of the Ordinances.

CHAPTER 14 DEFINITIONS

14.0 PURPOSE AND INTENT

For the purpose of this Ordinance, certain terms or words used herein shall be interpreted according to the rules and definitions of this Section, except when the context clearly indicates otherwise.

Whenever any words and phrases used herein are not defined but are defined in the State laws regulating the creation and function of various planning activities, any such definition therein shall be deemed to apply to such words and phrases used herein except when the context otherwise requires. All other words or phrases not herein defined shall be defined from the following resources in the order as listed below. The first resource to provide an appropriate definition for a word or phrase shall have supremacy over subsequent definitions.

Resource order for definitions:

- First, definitions as established and amended within the 2008 White County Zoning Ordinance definition section;
- Second, definitions as established and amended within the 1995 White County Zoning Ordinance definition section;
- Third, definitions as established and amended within the 1970-72 White County Zoning Ordinance definition section;
- Fourth, definitions found in any recent edition of Webster's dictionary, and;
- Finally, definitions for any words, terms or phrases not found in any resource identified above, the Staff shall use any resource available to them and shall determine the definition which will be utilized for zoning regulation purposes.

14.1 RULES

14.1.1 Word tense

Words used in the present tense include the future tense; words used in the future tense include the present tense; words used in the singular include the plural; and words used in the plural include words used in the singular.

14.1.2 Persons and other responsible parties

The word "person" includes an individual, firm, association, organization, partnership, trust, company, corporation, or any legal entity.

14.1.3 Masculine vs. feminine

Words used in the masculine include the feminine; words used in the feminine include the masculine.

14.1.4 Distinguishing between what is mandatory, permissive and preferred

The word “shall” is mandatory; the word “may” is permissive, and the word “should” is a preferred requirement.

14.1.5 Using and occupying a space

The words “used” or “occupied” include the words “intended, designed, or arranged to be used or occupied.”

14.1.6 Lot, plot or parcel

The word “lot” includes the words plot or parcel.

14.1.7 Time

The time within which any act required by this Ordinance is to be performed shall be computed by excluding the first day and including the last day, unless the last day is a Saturday or Sunday or a holiday declared by the United States Congress or the Indiana General Assembly, in which event it shall also be excluded. The word “day” shall mean a calendar day, unless otherwise indicated.

14.1.8 Captions, illustrations, and tables

In case of any difference of meaning or implication between the text of this ordinance and any caption, illustration or table, the text shall control and no caption, illustration or table shall be construed to limit the scope or intent of the text of this ordinance.

14.2 WORDS & PHRASES DEFINED

ABANDONMENT – The relinquishment of property or a cessation of the use of the property by the owner with the intention neither of transferring rights to the property to another owner nor resuming the use of the property.

ABUTTING – To physically touch or border upon; or to share a common property line.

ACCESS – A way or means of approach to provide physical entry to a property.

ACCESS ROAD – A street designed to provide vehicular access to abutting property and to discourage through traffic.

ACCESSORY STRUCTURE - A structure that is subordinate to a principal structure, and which does not change or alter the character of the premises. No mobile home, manufactured home, vehicle, tractor, semitrailer, hauling trailer, construction trailer, railroad boxcar, storage pod, shipping container or any other similar type unit may be used as an accessory structure in any residential or commercial district.

ACCESSORY USE – A use subordinate in area, extent and purpose to a principal use, that contributes to the comfort, convenience or necessity of a principal use, and that is located on the same or near-by (within 360 feet) lot; “near-by” meaning the closest points of each lot perimeter are not separated by more than three hundred sixty (360) feet.

ACCESSORY PORT - A temporary tubular, steel or wood framed structure not completely enclosed by walls or doors and which is open on at least two sides. An accessory port is similar to a car port but is not used for automobile parking.

ACRE – A measure of land area containing forty-three thousand five hundred and sixty (43,560) square feet.

ADDITION – Any construction that increases the size of a building or structure in terms of site coverage, height, length, width, or gross floor area.

ADMINISTRATOR - The official appointed and/or delegated the responsibility for the administration of these regulations of this Ordinance.

ADULT ENTERTAINMENT BUSINESS - Any adult bookstore, adult hotel or motel, adult motion picture arcade, adult motion picture theater, cabaret, sexual encounter center, or any other business or establishment that offers its patrons services or entertainment characterized by an emphasis on matter depicting, describing, or relating to specified sexual activities or specified anatomical areas, but not including those uses or activities, the regulation of which is preempted by state law. Access is restricted by age.

AGGREGATED PROJECTS – Projects which are developed or operated in a coordinated fashion, but which have multiple entities separately owning one or more of the individual WECS within the larger project. For the purpose of administering and enforcing this Chapter, all associated infrastructure, such as power lines or transformers or other components that service the WECS facility, while being owned by a separate entity or entities are included as part of an aggregated project.

AGRI-ANIMAL PRODUCTION – An operation or facility that uses small animal by-products or components for production of medical devices, food supplements or additives or other scientific or commercial purpose. Agri-Animal Production does not include aerobic or anaerobic digesters whether used as a principle use or an accessory use.

AGRI BIO PRODUCTION – An operation or facility that uses animal by-products, members, materials or component parts for production of medical devices, food supplements, food additives or other scientific or commercial purpose.

AGRICULTURAL INDUSTRY – Facilities where materials, used for the production of fuel alcohol and fertilizers are raised, grown, produced or processed for refinement. Sources may be plants grown especially for that purpose or waste products from livestock, harvesting, milling, or from agricultural production or processing.

AGRICULTURAL PRODUCE BUSINESS, PERMANENT - A permanently sited retail business engaged in the display and sale of agricultural produce and products.

AGRICULTURAL PRODUCE BUSINESS, SEASONAL - A temporary retail business in a permanent structure, engaged in the display and sale of agricultural produce and products, which are primarily grown in the season in which they are being sold.

AGRICULTURAL PRODUCE PRODUCTS – Nutritional food items or plant/seed items utilized in a cooking process such as fresh fruits, vegetables, meats and eggs grown on-site or locally, homemade food products, products made at facilities on-site, food products created by a limited or simplified process such as nuts, jams, jellies, popcorns, ciders, honey, syrups, flours, spices, etc., locally harvested plant and plant components. Complex food products such as mass-marketed products normally found in a grocery or convenience store are not included.

AGRICULTURAL PRODUCE SALES, PORTABLE – A portable structure or vehicle such as a truck, wagon, tent, or table, temporarily located at or adjacent to a site not owned by the owner of the portable structure or vehicle from which produce is sold, sometimes in conjunction with a Farmer’s Market.

AGRICULTURAL RESEARCH FIRM – A business that conducts research on agricultural or horticultural produce including, but not limited to, crops, vegetables, fruits, livestock, fish and poultry. Research work may be conducted in the field, greenhouse, and laboratory or enclosed housing facility.

AGRICULTURAL ROADSIDE STAND - A removable structure used or intended to be used solely by the owner or the tenant of a property on which it is located for the sale of seasonable agricultural products produced on the premises and to be removed and stored back of the building line on the property at the conclusion of the seasonal sales.

AGRICULTURE SERVICE & SUPPORT – A business which provides a direct service or product in support of farming activities or which manufactures or produces a product to be utilized by the farming industry and which has not been specifically delineated elsewhere.

AGRICULTURE – The use of land for agricultural purposes, including necessary buildings and structures which shall be used for such uses, but not limited to, farming, seed production and processing, dairying, pasturage, horticulture, floriculture, an animal and poultry husbandry and the necessary accessory uses for packing, treating or storing produce; provided, however, that the operation of any such accessory uses shall be secondary to that of the normal agriculture activities.

AIRPORT – Any area of land or water designated, set aside, used, or intended for use, for the landing and take-off of aircraft, and any appurtenant areas designated, set aside, used, or intended for use, for airport buildings or other airport facilities, rights-of-way, or approach zones, together with all airport buildings and facilities located thereon.

AISLE – The traveled way by which cars enter and depart parking spaces.

ALLEY – An unnamed public or private right-of-way that is primarily designed to serve as secondary access to the rear or side of those properties whose principal frontage is on some other street.

ALTERATION – Any change, addition, or modification in construction, other than cosmetic or decorative, or any change in the structural members of buildings such as bearing walls, columns, beams, or girders.

AMENITIES - Aesthetic or other characteristics of a development that increase its desirability to a community or its marketability to the public. Amenities may differ from development to development but may include such things as a unified building design, recreational facilities (e.g., a swimming pool or tennis courts), security systems, views, landscaping and tree preservation, or attractive site design.

AMPHITHEATER - A building or large open outdoor area or structure specifically designed and used as a place of assembly for band concerts, theatrical performances, games or other methods of entertainment, and partly or completely surrounded by tiers of seats for spectators.

AMUSEMENT PARK - An area of land which operates eight or more mechanical rides, games, concessions, various attractions, band concerts, theatrical performances or other methods of entertainment. These facilities are stationary and built for long-lasting operations and may require payment of a fee for entrance or entertainment activities. Excluded are municipally owned public parks.

AMUSEMENT PARK OFFICES – Offices used to conduct the daily activities of an amusement park.

ANIMAL - Any live or dead dog, cat, non-human primate, guinea pig, hamster, rabbit, or any other warm-blooded or cold-blooded animal, which is being used, or is intended for use for research, teaching, testing, experimentation, exhibition purposes, sale or as a pet. This term excludes: birds, rats of the genus *Rattus* and mice of the genus *Mus* bred for use in research, and horses and other farm animals, such as, but not limited to livestock or poultry, used or intended for use as food or fiber, or livestock or poultry used or intended for use for improving animal nutrition, breeding, management, or production efficiency, or for improving the quality of food or fiber. With respect to a dog, the term means all dogs including those used for hunting, security, or breeding purposes.

ANIMAL, DOMESTIC - An animal that is tame or domesticated and which is not normally found in the wild state and which is not classified or considered wildlife, livestock, or exotic animal. Hybrids of animals normally found in the wild state are not included within the meaning of domestic animal.

ANIMAL, EXOTIC - Means any animal that is not normally domesticated in the United States or is wild by nature. Exotic animals include but are not limited to, any of the following orders and families, whether bred in the wild or captivity, and also any of their hybrids with domestic species. The animals listed in parentheses are intended to act as examples and are not to be construed as an exhaustive list or limit the generality of each group of animals, unless otherwise specified: Non - human primates and prosimians (monkeys, chimpanzees, baboons); Felidae (lions, tigers, bobcats, lynx, cougars, leopards, jaguars, not domesticated cats); Canidae (wolves, coyotes, foxes, jackals, not domesticated dogs); Ursidae (all bears); Reptilia (all venomous snakes, all constricting snakes); Crocodilia (alligators, crocodiles); Proboscidae (elephants); Hyänenidae (hyenas); Artiodatyla (hippotamuses, giraffes, camels, not cattle or swine or sheep or goats); Procyonidae (raccoons, coatis); Marsupialia (kangaroos, opossums); Perissodactylea (rhinoceroses, tapirs, not horses or donkeys or mules); Edentara (anteaters, sloths, armadillos); Viverridae (mongooses, civets, and genets).

ANIMAL FOOD MANUFACTURING – A facility or operation which utilizes plant or animal materials to process and prepare in a manner intended for consumption by non-human animals.

ANIMAL SANCTUARY – A facility where animals are brought and provided a safe haven, normally for the rest of their lives. The animals are brought to the facility to live and be protected. These facilities do not seek to place animals with individuals or groups.

ANIMAL SHELTER – An establishment which provides temporary housing and care for dogs, cats and other small pets while offering such animals for adoption.

ANTENNA - Any system of wires, poles, rods, reflecting discs, or similar devices used for the transmission or reception of electromagnetic waves external to or attached to the exterior of any building or, for the purpose of wireless communication service, any communications equipment that transmits or receives electromagnetic radio signals used in the provision of wireless communications service.

ANTENNA, AMATEUR RADIO - An apparatus used to transmit radio signals as a pastime rather than as a profession.

ANTENNA, RADIO – An apparatus used to transmit and/or receive radio signals.

ANTENNA, TELEVISION – An apparatus used to transmit and/or receive television and/or satellite signals.

APARTMENT – A unit of one or more rooms within a residence, building or business which is dedicated to serve as a dwelling unit and which provides accommodations for sleeping, living, lavatory and kitchen facilities. The unit is designed for occupancy by only one (1) family.

APARTMENT, ACCESSORY - A subordinate dwelling unit contained on the same lot as the primary dwelling unit or a business, but located separate from the principal structure. The dwelling unit must be incorporated within an accessory structure and not utilize more than fifty (50) percent of the total square footage of floor space of the accessory structure. If the accessory structure has more than one floor, the total square footage is calculated by totaling up the square footage of each floor.

APARTMENT, BUILDING – A building which provides three (3) or more dwelling units.

APARTMENT, MICRO-UNIT – A studio or efficiency apartment defined primarily by its size and occupancy. Micro-units consist of a kitchen or built-in kitchenette, bathroom and with combined living room/sleeping quarters. The units are limited to no more than 325 square feet and are restricted in occupancy to a maximum of two people. Micro-unit apartments may only be located within a municipality, require approval of the local legislative body and are restricted to B-1 & B-4 zoning districts. These units are exempt from the dwelling unit size requirements of Appendix B: Bulk Use Standards.

APIARY – A place where a colony or colonies of domestic honey bees are kept such as, but not limited to, a beehive(s) or bee house(s) (a small, wall-less, roofed structure), where domestic honey bees are raised to produce honey or to promote plant life pollination.

APPLICANT - The owner of land, engineer or contractor who makes application to the White County Area Plan Commission or Board of Zoning Appeals for action by said Commission or Board, affecting that land.

ARCADE - A building or part of a building containing four or more game machines, instruments or apparatuses operated by coin, slug or similar medium, but not including automatic machines for vending food, soft drinks or tobacco, and outside service vending machines.

AREA, GROSS – All areas (whether covered by land or water or rights-of-way) contained within the perimeter property boundaries of a proposed project.

AREA, NET – The land area of a parcel excluding those areas that contain structures, parking or other impervious surfaces, and non-buildable natural features such as wetlands, woodlands, natural habitats, and the like as specifically described.

AREA PLAN COMMISSION – A County Plan Commission serving multiple local government jurisdictions established as defined under the IC 36-7-4-200, etc. al, as amended. The White County Plan Commission is an Area Plan Commission.

ASPHALT PLANT (MANUFACTURING) – An operation for the manufacture of asphalt, macadam and other forms of coated road stone, sometimes collectively known as blacktop.

ASSISTED LIVING FACILITY - A multiple family structure, controlled either by a public body, institutional body, or nonprofit corporation, a majority of whose occupants shall be 65 years of age or over, or a multiple family structure where each unit is occupied by at least one (1) person who is 55 years of age or over and is retired, and where the rental arrangement includes primarily non-medical services to deal with the activities and instrumental activities of daily living.

AUCTION – A sale of goods or services where prices are established through a process of competitive and open bidding.

AUCTION, SALE – An auction which takes place as a sporadic event to dispose of either personal or real property or as a fund-raising event for a non-profit organization.

AUCTION ARENA OR SALES BARN FOR LIVESTOCK – A barn or other accessory building or area on agricultural land designed, constructed, and used to house livestock and related uses for the purpose of selling livestock to buyers.

AUCTION ARENA OR SALES YARD (EXCLUDING LIVESTOCK) - A building, area, or areas within a building used for the public sale of goods, wares, merchandise, or equipment to the highest bidder through open public bidding.

AUTOMATED TELLER MACHINE (ATM) - A mechanized device that performs financial functions, whether outside or in an access-controlled facility.

AUTOMOBILE CONVENIENCE MART – A place where gasoline, motor oil, lubricants, or other minor accessories are retailed directly to the public on the premises in combination with the retailing of items typically found in a convenience market or supermarket.

AUTOMOBILE PARTS/SUPPLY RETAIL ESTABLISHMENT – A store that displays and sells new or used automobile parts, tires, and accessories. May also include minor installation.

AUTOMOBILE RENTAL/LEASING ESTABLISHMENT - Leasing or renting of automobiles, motorcycles, and light load vehicles.

AUTOMOBILE SALES – The use of any building or portion thereof, or other premises or portion thereof, for the display, sale, rental, or lease of new motor vehicles, or used motor vehicles as an ancillary use of a zoning lot, and any warranty repair work and other repair service conducted as an accessory use.

AUTOMOBILE SALES LOT – That area dedicated to the display of vehicles which are for sale or lease. This area is exclusive of any area utilized for off-street parking.

AUTOMOTIVE SERVICE, MAJOR - The replacement of any part or general repair, rebuilding or reconditioning of engines, passenger cars, commercial vehicles or trailers, including body work, framework, welding and major painting service. Above stated is applied to passenger vehicle(s).

AUTOMOTIVE SERVICE, MINOR - The service and maintenance of equipment and parts, including oil change and lubrication, muffler shops, tire sales and installation, wheel and brake shops, automobile detailing, or installation of CB radios, cellular phones, car stereos, or car alarms. Above stated is applied to passenger vehicle(s), and is typically accomplished without keeping vehicle overnight.

AUTOMOBILE/TRAILER SALES AREA - An open area, other than a street, used for the display, sale or rental of new or used motor vehicles or trailers to be displayed, sold or rented on the premises.

AWNING - Any structure made of cloth or metal with a frame attached to a building, when the same is so erected as to permit its being raised to a position flat against the building when not in use.

B

BACK-OUT AISLE - The area behind a parking space for the purpose of providing maneuvering room for a vehicle to pull in and out of a parking space.

BAIT SALES – An establishment that sells bait such as minnows, crickets, worms, and other similar bait and other fishing gear used for recreational fishing.

BAKE SALE – A fundraising activity where baked goods such as doughnuts, cupcakes, cookies, & ethnic foods are sold.

BAKERY OR DELICATESSEN - An establishment primarily engaged in the retail sale of baked products for consumption off site. The products may be prepared either on or off-site. Such use may include incidental food service.

BALCONY - A stick-built platform which is a horizontal extension from an upper-level floor and which is generally enclosed on three sides by a parapet or railing and is utilized in a manner similar to a deck or terrace.

BALLROOM – A large room used for dances.

BANK – An establishment for the custody, loan, exchange, or issue of money, for the extension of credit, and for facilitating the transmission of funds.

BANNER – A sign of lightweight, flexible, and temporary material such as cloth or plastic that is attached to a building, structure, or other support in such a manner as to allow movement caused by the atmosphere.

BANNER, FIXED – A sign of lightweight fabric or similar material that is permanently mounted to a pole or building by a permanent frame at two or more edges.

BANQUET HALL - A facility or hall available for lease by private parties.

BARRIER, FLYWAY – Fencing, dense hedging or obstacle, or combination thereof, which provides a shield or protective barrier from the direction in which honey bees fly when approaching or leaving a apiary; i.e., a man made or man placed item which causes an alteration in a bees flight pattern.

BASE STATION – A station located at a specific site that is authorized to communicate with mobile stations. The term includes all radio transceivers, antennas, coaxial cables, power supplies, and other electronics associated with a station.

BASEMENT – The portion of a building with more than half of its height below the ground. For the purposes of this Ordinance, a basement shall not be considered a story unless it has been subdivided into rooms and used for tenant purpose.

BATHHOUSE – A use or business that provides the services of baths of all kinds, including all forms and methods of hydrotherapy, unless operated or supervised by a medical or chiropractic practitioner or professional physical therapist licensed by the state.

BATTERY STORAGE, COMPOUND – The fenced area which encloses the land upon which battery storage units are to or have been placed. Land area used for the infrastructure required to connect the battery storage units to a utility service is not included.

BATTERY STORAGE, FIELD – An area of land dedicated primarily for the purpose of locating multiple (more than 3) large, commercial battery storage units which are intended to capture power from an energy production source for future release to the electrical grid.

BATTERY STORAGE, RETROFIT – The placement of large, commercial battery storage units within an established (permit approved) energy production project area.

BATTERY STORAGE, PROJECT AREA – The area defined by the perimeter property lines, (those property lines not shared with another participating property owner) of all parcels/lots of land identified as participating property owners in a common battery storage field, including any abutting rights-of ways captured within two or more participating properties.

BATTING CAGES, COMMERCIAL – A structure in which a batter practices, typically consisting of three sides and a top in utilizing netting or fence material to contain missed or fouled pitches and are available for use for at a set fee.

BAZAAR – A fair for the sale of articles or goods generally for charitable purposes.

BEACON – Any light with one or more beams directed into the atmosphere or directed at one or more points not on the same zone lot as the light source; also, any light with one or more beams that rotate or move.

BED AND BREAKFAST - A short term rental unit operating out of a residential structure, other than a boarding house, where the operator of the establishment resides on the premises or adjacent premise. A Bed & Breakfast offers short-term rentals which last less than 30 days and which includes sleeping accommodations and a morning meal. A B&B consists of no more than six (6) sleeping rooms and may have shared bathroom facilities. The facility offers a common kitchen and dining area. Use is restricted to a single-family dwelling unit with additional rooms utilized for short term rentals. If approved by the Area Board of Zoning Appeals, such a facility may facilitate large group activities such as weddings, anniversaries, retirement celebrations, bachelor/bachelorette parties, etc. In these cases, the owner must demonstrate to the Board that the facility provides adequate parking, individual capacity, safe pedestrian circulation and any facility needs deemed appropriate by the Board of Zoning Appeals.

BEE, COLONY – An entire honey bee family or social unit living together including the queen, workers and drones.

BEE, DOMESTIC HONEY – A classification of bee limited to the Apis mellifera species and specifically excludes the African honey bee, Apis mellifera scutellata or any hybrid thereof.

BEEKEEPER – A person(s) who owns or controls a Beehive(s) or bee house(s), or combination thereof, or a person(s) responsible for the keeping of Domestic Honey Bees.

BEEHIVE (HIVE) – Any naturally created domicile for honey bees.

BEEHIVE, ASSISTED – An enclosed frame or structure, erected with the assistance of humans and used or employed as a domicile for honey bees.

BIO-MEDICINE – A facility or operation which applies biology and physical sciences to clinical medicine.

BIO-PROCESSING, PLANT – A facility where processes or techniques utilizing biological agents, microorganisms, biologically derived macromolecule, living cells or their components, carry out enzymatic reactions or to manufacture products or produce a desired end product.

BLIGHTED AREA - An area in which normal development and occupancy are undesirable or impossible because of: lack of development; cessation of growth; deterioration of improvements; character of occupancy; age; obsolescence; substandard buildings; or other factors that impair value or prevent a normal use or development of property. Refer to IC 36-7-1-3, as amended.

BLOCK - A tract of land bounded by streets, or by a combination of streets and railroad rights-of-way, waterways, boundary lines of municipalities, or other barriers.

BLOCK FACE - The properties abutting on one side of a street and lying between the two nearest intersecting streets.

BOARD - The White County Board of Zoning Appeals (BZA).

BOARDING HOUSE/ROOMING HOUSE – An owner occupied, single family dwelling other than a motel, hotel or lodge, where for compensation and by arrangement, lodging is provided. Meals may or may not be provided, but there is one (1) common kitchen facility. No meals are served to outside guests.

BOAT SALES AND SERVICE – A marine retail sales and service use in which boats or personal water craft are rented or sold. The sale or rental of smaller boats shall be defined as a major durables sales and service use.

BOAT STORAGE, COMMERCIAL – A facility or area where boats are stored for a fee.

BOAT, WATERCRAFT – Any vehicle designed for travel on water that uses an outboard motor, inboard motor or a water jet pump as its sole source of power.

BODY PIERCING – The piercing of holes in parts of the body, other than the ear, in order to insert jewelry or other decorative objects.

BOND - A form of security including a surety bond, in an amount and form satisfactory to the Area Plan Commission.

BOTANICAL GARDEN/BOTANIC GARDEN/ BOTANICAL INSTITUTION – A garden for the culture of plants collected for scientific, educational and ornamental purposes which may include an outdoor garden area(s), one or more greenhouse, herbarium and arboretum areas, library and research laboratory.

BOTTLED GAS STORAGE AND DISTRIBUTION YARD – A commercial operation in which the primary business is a storage yard where bottled gas is stored, distributed, or sold, wholesale or retail. Not included are storage, distribution and use as part of a farm operation.

BOWLING ALLEY - An indoor facility for the sport of ten-pin or duck-pin- bowling, with customary accessory uses such as snack bars.

BREEZEWAY - A roofed structure which is open on two sides and which connects a home to a second structure via a roofline (normally a garage).

BREW PUB – A producer of beers and malt beers with annual production levels less than 15,000 barrels (1 barrel = 31 gallons) which brews and sells its production on-site in packaged or unpackaged form where 25% or less of its production is sold off-site. The establishment may or may not sell signature and/or gift items, complimentary products and/or food within the confines of their retail floor space; however, food sales may not exceed 50% of total sales (having annual food sales in excess of 50% establishes a restaurant for purposes of this Ordinance). No outside storage of finished products, raw materials or process related items (such as barrels, bottles, cases, etc.) takes place. The business and its site must comply with any federal, state or local laws, statutes or regulations in addition to Zoning Ordinance requirements.

BREWERY – A business which manufactures beers and malt beers at a level of 6,000,000 US barrels (1 barrel = 31 gallons) or more for distribution and does not offer on-premise, retail sales of its beverages; although, it may provide a tasting room and have retail space where signature and gift items are made available for sale. There are no beer sales conducted on-site in either packaged or unpackaged form. The business will generally have outside storage of materials and supplies related to the production or distribution of their products. The business and its site must comply with and federal, state or local laws, statutes or regulations in addition to Zoning Ordinance requirements.

BREWERY, CRAFT – A small, independent producer of beer and malt beers with annual production levels not exceeding 6,000,000 US barrels (1 barrel = 31 gallons) and does not offer on-premise, retail sales of its beverages; although, it may provide a tasting room and have retail space where signature and gift items are made available for sale. There are no beer sales conducted on-site in either packaged or unpackaged form. The business will generally have outside storage of materials and supplies related to the production or distribution of their products. A craft brewery cannot be more than 24% owned by another alcoholic beverage company that is not itself a craft brewery. The business and its site must comply with any federal, state or local laws, statutes or regulations in addition to Zoning Ordinance requirements.

BREWERY, MICRO – A producer of beers and malt beers with annual production levels less than 15, 000 barrels (1 barrel = 31 gallons) where on-premise, retail beer and malt beer sales in packaged and unpackaged form occur but do not exceed 25% of the location's annual production. The establishment may or may not sell signature and/or gift items, complimentary products and food within the confines of their retail floor space; however, food sales may not exceed 50% of total sales (having annual food sales in excess of 50% establishes a restaurant for purposes of this Ordinance). No outside storage of finished products, raw materials or process related items (such as barrels, bottles, cases, etc.) takes place. The business and its site must comply with any federal, state or local laws, statutes or regulations in addition to Zoning Ordinance requirements.

BUFFER AREA – Land area used to visibly separate one use from another or to shield or block noise, lights, or other nuisances.

BUILDER – A person, firm, company, or entity who is responsible for the construction related to an issued Building Permit(s).

BUILDING - A structure having a roof supported by columns, extended joists or walls, for the enclosure, support or protection of persons, animals, chattels or other property.

BUILDING AREA - The maximum horizontal projected area of the principal and accessory building, excluding open steps or terraces, unenclosed porches not exceeding basements, or architectural appurtenances.

BUILDING, AGENCY OR DEPARTMENT – A building which houses one or more departments or agencies of a branch of government and which does not utilize outside storage, heavy truck traffic, industrial type of but not be limited to, Highway or Street Department, Fire Department, Police Department or Ambulance Service.

BUILDING, ATTACHED - A building that is structurally connected to another building by foundation, common wall, or roofline. Future expansion of a building shall be connected by foundation, common wall, Roofline, or breezeway.

BUILDING CODE - The County ordinance establishing and controlling the standard for constructing buildings, utilities, mechanical equipment and all forms of structures and permanent installations and related matters, within the County. It also referred to herein as the Building Code of the County of White, Indiana, Ordinance No. 01-03-05-01 and amendments thereto.

BUILDING COMMISSIONER - Building Commissioner shall be synonymous with the term Building Inspector, and shall refer to the person employed and delegated the primary responsibility of issuing building permits and conducting inspections of same.

BUILDING, DETACHED - A building having no structural connection with another building.

BUILDING, GOVERNMENT – A building that houses a branch of government.

BUILDING, HEIGHT OF - The vertical distance from the finished ground level at the wall of the building nearest and most parallel to the front lot line (measured as an average of the ground level at its two furthest corners). Chimneys, spires, towers, elevator penthouses, tanks and similar projections other than signs shall not be included in calculating the height.

BUILDING PERMIT – A certificate issued by the Administrative Officer, permitting a person, firm or corporation to erect, construct, enlarge, alter, repair, move, improve, remove, convert, or demolish any building or structure within its jurisdiction, or cause the same to be done.

BUILDING, PRINCIPAL - A building in which the primary use of the lot on which the building is located is conducted.

ACCESSORY STRUCTURE AND PRINCIPAL BUILDING DEFINITION

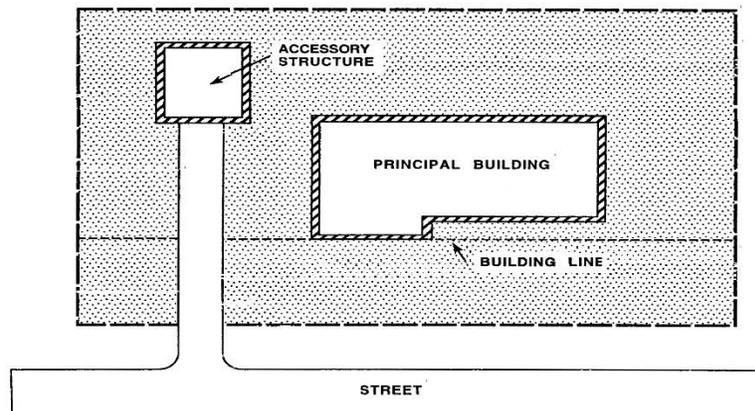

BUILDING SETBACK - A line parallel to and equidistant from the relevant lot line (front, back, side) measured from the property line, defining the limits of a yard in which no building, other than a permitted accessory building or structure, may be located above ground, except as may be provided by the Development Standards in this Ordinance. The setback is measured to the foundation of the building unless the structure has an overhang greater than sixteen (16) inches, in which case the setback is measured to the overhang.

BUILDING SITE – An area proposed or provided by grading, filling, excavating or other means for erecting pads, slabs, or foundations for buildings.

BUILDING SIZE - The gross, horizontal area within the perimeter of the exterior walls of the building located on the first or nearest ground level floor excluding open areas or terraces; unenclosed porches, decks and/or protruding architectural features.

BUILD-TO-LINE - An alignment established a certain distance from the right-of-way line to a line along which the building shall be built.

BUNKHOUSE - An accessory structure, or portion thereof, which provides temporary sleeping quarters for the sole use of persons employed on the premises. Such quarters shall not be rented or otherwise used as a separate dwelling unit. Such quarters may have plumbing facilities such as a sink, toilet and/or shower but are not allowed to have kitchen facilities.

BUS - A vehicle with capacity of eight (8) or more passengers which charges a fare to transport people from one point to another, usually along a pre-determined route, or is chartered by a large group to go from one point to another. The driver is an employee or volunteer of a company or organization

BUS LOT - Any lot or land area used for the storage or layover of passenger buses or motor coaches.

BUS GARAGE - A building or portion thereof, privately owned and operated, used for the storage, maintenance or service of commercial buses.

BUS STATION, PASSENGER – Any premises for the transient housing or parking of motor driven buses, and the loading and unloading of passengers.

BUSINESS - The engaging in the purchase, sale, barter or exchange of goods, wares, merchandise or services; or the maintenance or operation of offices; or the maintenance or operation of recreational and amusement enterprises for profit.

C

CABANA – A shelter resembling a cabin or hut usually with an open side facing a beach or swimming pool. Usually used as a beach or pool accessory structure.

CABIN (Mini Vacation Home) – A building with minimum living space of 300 square feet usually containing only sleeping rooms, a small gathering room, lavatory and a kitchenette or small kitchen and which is available for rent on a short-term basis (less than 30 days). A cabin will be treated as a permitted (allowed) use in any State Regulated Camp Ground or Mobile and Manufactured Home Park regardless of the zoning district in which the Camp Ground or Park is located and permitted (allowed) in any AED District; otherwise is subject to Special Exception Use approval from the Area Board of Zoning Appeals and must meet the Special Exception Use Standards of a Vacation Home.

CAMPGROUND- A primitive and/or improved parcel of land used or intended to be used for temporary occupancy by campers, through the use of recreational vehicles, travel trailers, mobile homes, tents, cabins, or other temporary accommodations.

CANOPY – Any structure, other than an awning, made of cloth, metal or wood with frames attached to a building, projecting over a sidewalk.

CAR WASH - An area of land and/or a structure with machine or hand operated facilities used principally for the cleaning, washing, polishing, and/or waxing of motor vehicles.

CARETAKER HOME – A permanent residence, secondary and accessory to an existing main dwelling for persons employed principally on-site for purposes of care and protection of persons, property, plants, animals, equipment or other circumstances on-site or on contiguous lots under the same ownership.

CARNIVAL – A traveling amusement establishment usually including rides, games, and sideshows.

CARPORIT - A covered automobile parking space not completely enclosed by walls or doors and is open on at least two sides.

CASINO – A building in which one or more gaming tables, wagering devices or machines, or other games of chance are present and available for persons to wager money or something of value on an uncertain outcome, with an unassured prospect of winning money or other stakes, prizes, or something of value, including by way of illustration, but not limitation: bingo, keno, raffles, video poker, roulette, pari-mutuels, blackjack and other card games; excluding those gambling or gaming establishments whose location and/ or right to operate is preempted by state law.

CATERING SERVICE – An establishment that serves and supplies food to be consumed off premises.

CEMETERY - Land used for the burial of the dead and dedicated for cemetery purposes, including columbariums, crematories, mausoleums and mortuaries when operated in conjunction with and within the boundary of such cemetery.

CERTIFICATION OF OCCUPANCY - A certificate signed by the Building Commissioner stating that the occupancy and use of land or a building or structure referred to therein complies with the provisions of this Ordinance and other applicable County Ordinances.

CHICKEN – A domestic fowl (*gallus domesticus*), a subspecies of the red junglefowl.

CHICKEN COOP (HEN HOUSE) – A structure for the sheltering of chickens.

CHICKEN HEN – A common, female chicken or its young up to 12 weeks of age.

CHICKEN PEN – A contained area that is connected to and/or surrounding a chicken coop for the purpose of allowing chickens to leave a chicken coop while remaining in an enclosed, predator safe environment.

CHILD CARE CENTER – A non-residential building where at least one (1) child receives child care from a provider;

- (1) While unattended by a parent, legal guardian, or custodian;
- (2) For regular compensation; and
- (3) for more than four (4) hours but less than twenty-four (24) hours in each of ten (10) consecutive days per year, excluding intervening Saturdays, Sundays, and holidays; as defined in IC 12-7-2-28.4 as amended.

CHILD CARE HOME – A residential structure that serves any combination of full-time and part-time children in accordance with IC 12-7-2-33.7 (Class I) and IC 12-7-2-33.8 (Class II)

CHILD CARE HOUSE – A residence in which no more than five (5) children at any time receive child care from a provider, not including the children for whom the provider is a parent, step-parent, guardian, custodian, or other relative or any child who is at least fourteen (14) years of age and does not require child care.

CHILDREN’S PLAY EQUIPMENT – Age-appropriate recreational equipment that enables children to develop physical coordination, strength and flexibility as well as providing recreation and enjoyment.

CHRISTMAS TREE SALES - A retail sales operation generally conducted wholly out-of-doors, that offers for sale on a temporary, limited basis Christmas trees and related holiday items such as wreaths and Christmas tree stands.

CIRCUS – A form of entertainment typically presented in one or more very large tents or an outdoor and/or indoor area featuring exhibitions of pageantry, feats of skill and daring with a variety of performances by acrobats, trapeze artists, clowns and trained animals.

CLUB OR LODGE, PRIVATE - Building and facilities owned or operated by a person or organization for a social, educational, or recreational purpose, but not primarily for profit or to render a service which is customarily carried on as a business.

COLLOCATION – The placement or installation of a wireless facility on existing structures that include a wireless facility or a wireless support structure, including water towers and other buildings or structures.

COMMERCIAL SOLAR ENERGY SYSTEM (See SOLAR ENERGY SYSTEM, COMMERCIAL)

COMMISSARY – An establishment where food is stored, prepared, portioned, or packaged or any combination of these, where such food is intended for consumption at another establishment or place. It is also the place which is used as the base operations for one or more mobile food service vehicles or push carts, where such unit or units are serviced, cleaned, supplied, maintained, and where equipment, utensils and facilities are serviced, cleaned and sanitized.

COMMISSION - The White County Area Plan Commission.

COMMISSIONERS, COUNTY - Whenever the term “Commissioners” is used in this Ordinance, it shall mean the Board of County Commissioners of White County, Indiana, unless otherwise designated.

COMMUNICATIONS EQUIPMENT BUILDING - An unmanned building or cabinet containing communications equipment required for the operation of communications antennas.

COMMUNICATIONS SERVICE PROVIDER – A person or entity that offers communications service to customers in Indiana, without regard to the technology or medium used by the person or entity to provide the communications service. This term includes a provider of commercial mobile service as defined in 47 U.S.C. 332.

COMMUNICATIONS TOWER, HEIGHT OF - revised and moved to “W’s”

COMMUNICATIONS TOWER, MONOPOLE - revised and moved to “W’s”

COMMUNITY CENTER – A building utilized by members of a community for social or cultural activity which may include facilities for recreational purposes.

COMMUNITY COMMONS - An area of land not more than 20,000 square feet, normally located within an urban area and along a pedestrian corridor, committed to providing a public place for short term rest and relaxation and which does not include recreational facilities but which might include various types of seating arrangements and other low-key amenities.

COMPACT HOUSE - A free standing light framed or masonry constructed home which is utilized as a primary dwelling and which has not less than 300 square feet or more than 600 square feet of living space.

COMPREHENSIVE PLAN - The official policy document which establishes development goals and objectives to guide growth within and around White County in a coordinated manner, prepared by the White County Area Plan Commission and adopted in accordance IC 37-7-4 500 Series.

CONCESSION STAND – An accessory structure or portion of a principal structure utilized for the sale of concessions.

CONCESSIONAIRE – A person, firm, business or other entity that sells concessions from a concession stand.

CONCESSIONS – The sale of confections, snacks, or other light meals and providing no inside seating nor drive-in service for the customers.

CONCRETE OR CEMENT BATCHING PLANT, PERMANENT – A manufacturing plant, utilizing at least some permanently secured pieces of equipment, where concrete is mixed before being transported to a construction site ready to be poured.

CONCRETE OR CEMENT BATCHING PLANT, PORTABLE – A manufacturing plant where the equipment is installed on a temporary basis and concrete is mixed at or next to the construction site with capacities limited to 2,000 yards or less per day.

CONDOMINIUMS - A form of property ownership where a multiple dwelling or development containing individually owned dwelling units and jointly owned and shared areas and facilities, which dwelling or development is subject to the provisions of Indiana and other applicable local laws.

CONFERENCE CENTER/MEETING HALL – A building or large room used for meetings, conferences, public or social gatherings or entertainment activities which may allow catering services or provide a kitchen for use by event sponsors.

CONFERENCE FACILITY - A facility used for service organizations, business and professional conferences and seminars limited to accommodations for conference attendees. The accommodations can include sleeping, eating and recreation.

CONFINED FEEDING OPERATION- The confined feeding of animals for food, fur, or pleasure purposes in lots, pens, ponds, sheds, or buildings where, animals are confined, fed, and maintained, excluding a livestock market where animals are assembled to be publicly auctioned or privately sold on a commission basis and that is under state or federal supervision; or as otherwise defined by the Indiana Department of Environmental Management.

CONSERVATION LANDS, PUBLIC – Land owned in fee title by any city, county, state, or federal agency, or non-profit conservation organizations, and managed specifically for conservation purposes.

CONSERVATORY - A room with a glass roof and walls, attached to a house or other building at one side and used as a greenhouse or a sun parlor.

CONSTRUCTION BUILDING – A mobile home, travel trailer, truck trailer, or other structure used as an office in conjunction with a construction project.

CONSTRUCTION, HEAVY CONTRACTORS - The process of adding infrastructure to our built environment. Owners of these projects are usually government agencies, either at the national, state or local level. Unlike building construction, heavy/civil construction projects are not typically undertaken for-profit. Rather, the projects are intended to service the public interest.

CONSTRUCTION YARD - An area on or immediately adjacent to a major construction or demolition site used on a temporary basis for the parking and storage of equipment used in the project, and the storage and preparation of materials and other items used in the project. Such yard may include construction offices and such shops as are necessary for work on the immediate site.

CONVENIENCE STORE, NEIGHBORHOOD - A retail store that sells groceries and household items, but does not have restaurant seating or gasoline sales.

CONVENIENCE STORE, REGIONAL - A retail store that sells groceries and household items, and which may also provide other convenience services such as restaurant, laundromat or vehicular fuel sales for class I or II commercial vehicles. Such uses are considered to be accessory uses and not a separate business.

CONVENTION CENTER/EXHIBITION HALL – A building or group of buildings which are designed for the primary use of housing conventions, industrial shows, exhibitions and the like where individuals and groups gather to promote and share common interests. These facilities make available large, unobstructed exhibit areas and also may include conference rooms, hotel accommodations, restaurants and other amenities for the benefit of attendees and/or exhibitors and may be used to accommodate sporting events, circus type activities, rodeos, entertainment events or other uses requiring a large venue.

CONVERSION - A change in the use of land or structure.

CORRECTIONAL/PENAL FACILITY - Public or privately-operated facilities housing persons awaiting trial or persons serving a sentence after being found guilty of a criminal offense.

COTTAGE/SUMMER HOME – A building with minimum living space of 300 square feet, utilized by its owner as temporary housing for vacationing or rest and relaxation, but not utilized as a primary or year-round dwelling or for rental purposes.

COUNTY - White County, Indiana.

COURT - An open, unoccupied and unobstructed space other than a yard on the same lot with a building or group of buildings.

COVENANT - A private legal restriction on the use of land contained in the deed to the property and otherwise formally recorded.

CREMATORY - A furnace or establishment for the incineration of corpses.

CULVERT - A drainpipe that channels water under a bridge, street, or driveway.

CUT - The material removed in excavation. The difference between a point on the original ground and a designated point of lower elevation on the final grade.

D

DAY CARE CENTER, ADULT - A facility providing care for the elderly and/or functionally impaired adults in a protective setting for a portion of a twenty-four (24) hour day.

DECK - 1) A stick-built platform which is located adjacent to a building or structure and is constructed at or above the first (main) floor level of the building, but not at an elevation beyond the height of the first floor level of a building; 2) A stick built platform which is located away from a building, typically adjacent or near a water source and which is located no more than six feet above grade.

DEDICATION – The transfer of private property to public ownership upon written acceptance.

DENSITY - The number of dwelling units permitted per gross acre of land.

DEPARTMENT STORE – A retail store that sells a wide variety of goods arranged in several departments.

DETENTION AREA - An area that is designed to capture specific quantities of storm water and to gradually release the storm water at a sufficiently slow rate to avert flooding.

DEVELOPER - The owner of land or his representative proposing changes to a parcel or parcels of land, including development, lot improvement or subdivision of land.

DEVELOPMENT - Any man-made change to improved or unimproved real estate including but not limited to construction, reconstruction, or placement of a building or any addition to a building which increase its usable space. The term “development” does not include activities such as the maintenance of existing buildings and facilities such as painting, re-roofing, resurfacing roads, or gardening, plowing, and similar agricultural practices that do not involve filling, grading, excavation, or the construction of permanent buildings.

DEVELOPMENT STANDARDS - Regulations such as bulk, height, area, or open space requirements set forth by ordinance approving the proposed development.

DIGESTER - A vessel or tank in which organic or chemical reactions take place for the decomposition of human or animal waste and other organic waste products. A digester is considered an accessory use when the electricity and/or gas produced by the digester is used entirely on site. A digester is considered a commercial use when some or all of the electricity and/or gas produced by the digester is sold to an off-site party.

DIGESTER, AEROBIC – A process by which microorganisms access free gaseous oxygen from the surrounding atmosphere and, thereby, are able to convert, suspend or dissolve waste products into alternative forms.

DIGESTER, ANAEROBIC – A process by which microorganisms, in the absence of gaseous oxygen, convert waste products into a biogas which is then burned to produce heat, electricity and water.

DISTILLERY - A processing facility where distilling of alcoholic liquors takes place in large volume (annual production greater than 1700 cases or 4,041 gallons of finished product). All products are distributed to off-site, unrelated, commercial entities with no on-site retail sales of their products. The business may have a tasting room and offer signature or other gift items for sale. The business will typically have outside storage of product and supplies affiliated to production and distribution of their products. The business and its site must comply with any federal, state or local laws, statutes or regulations in addition to Zoning Ordinance requirements.

DISTILLERY, MICRO OR BOUTIQUE – A small processing facility where distilling of alcoholic liquors takes place and which is limited in production to no more than 1700 cases or 4,041 gallons of finished product a year. A micro or boutique distillery may also operate a tasting room, provide retail sales of their packaged product, retail sales of signature and gift items and provide food service where food service is limited to no more than 50% of total sales (having annual food sales in excess of 50% establishes a restaurant for purposes of this Ordinance). No outside storage of finished products, raw materials or process related items (such as barrels, bottles, cases, etc.) takes place. The business and its site must comply with any federal, state or local laws, statutes or regulations in addition to Zoning Ordinance requirements.

DISTRIBUTION CENTER - A use where goods are received and/or stored for delivery to the ultimate customer at remote locations.

DRAINAGE SYSTEM - All facilities, channels, and areas, which serve to convey, filter, store, and/or receive storm water, either on a temporary or permanent basis.

DRAKE – A male aquatic bird or waterfowl with a broad blunt bill, short neck and legs, webbed feet and a waddling gait in the family Anatidae. The word does not include swans and geese.

DRIP LIINE - The imaginary circle drawn on the soil around a tree directly under its outermost branch tips; the boundary of a tree's canopy.

DRIVE-UP WINDOW – Any establishment providing service from a building directly to a customer in an automobile or other vehicle.

DRIVEWAY – A paved, concrete, graveled or dirt access strip of land which has not been dedicated to the public and which is used for vehicular access between a public way or private road and the improvements on one or more lots, parcels or tracts of land.

DRIVING RANGE – An area equipped with distance markers, clubs, balls, and tees for practicing golf drives.

DRUG STORE - A retail store where medicines and miscellaneous articles are sold.

DUCK – A female aquatic bird or waterfowl with a broad blunt bill, short neck and legs, webbed feet and a waddling gait in the family Anatidae. The word does not include swans and geese.

DWELLING - A building or portion thereof, used as a place of residence for one or more human beings, but not including mobile homes, hotels or motels, lodging or boarding houses.

DWELLING, ATTACHED SINGLE-FAMILY - Single-family dwelling units attached by a common wall or walls, and legally platted so that each unit sits on an individual lot providing for fee simple ownership of each lot. This type of dwelling may or may not have additional common grounds owned by a homeowner's association.

DWELLING, FARM - A dwelling, located on a farm, for the purpose of housing an owner or employee of that farm or agricultural operation and his/her family.

DWELLING, MULTI-FAMILY - A single, residential structure consisting of three (3) or more dwelling units. These units are to be occupied by one family each. The dwelling units may or may not be located in a single structure.

DWELLING, SINGLE FAMILY - A free-standing, detached residential structure which consists of one (1) dwelling unit per lot to be occupied by one (1) family.

DWELLING, STUDENT/FRATERNITY/SORORITY – A building or buildings with the primary use of providing temporary housing for students, fraternity or sorority members or for people with temporary educational needs, but not including hotels, motels, resorts, boarding or rooming houses.

DWELLING, TWO FAMILY (DUPLICATE) – Dwelling, Two Family, or Duplex: A single, free-standing, detached residential structure which consists of two (2) dwelling units where each dwelling unit is occupied by one family and has direct access to the outside.

DWELLING UNIT - A dwelling or part of a dwelling used by one family as a place of abode, physically separated from any other dwelling units which may be in the same structure and containing independent cooking, bathroom and sleeping facilities.

DWELLING UNIT, SUBORDINATE: A free-standing, single-family dwelling unit which does not exceed 75% of the gross floor area of the primary dwelling unit. Subordinate dwelling units may not be used for short-term rental purposes. A property which includes a principal dwelling unit may not also include an apartment or accessory apartment on the property.

E

EASEMENT - The right of a person, government agency, or public utility company to use, for a specific purpose, the public or private land owned by another.

EDUCATIONAL FACILITY, OTHER – A facility, outside an elementary, secondary or collegiate institution, where individuals are taught specific skills in areas such as manufacturing or construction trades, dancing, singing, arts, business or where specialized technical training is provided.

EDUCATIONAL FACILITY, PRIVATE - Any building or group of buildings, the use of which meets state requirements for primary, secondary, or higher education and which does not secure the major parts of its funding from any governmental agency. This includes any and all related uses, such as ball fields, batting cages, tennis courts, concessions, etc.

EDUCATIONAL FACILITY, PUBLIC - Any building or group of buildings, the use of which meets state requirements for primary, secondary, or higher education and which secures the major parts of its funding from governmental agencies. This includes any and all related uses, such as ball fields, batting cages, tennis courts, concessions, etc.

EDUCATIONAL INSTITUTION - A pre-primary, primary, grade, junior high, high, or preparatory school or academy; or a junior college, college or university, whether public or founded or conducted by or under the sponsorship of a religious or charitable organization.

EGRESS – An exit.

ELECTRIC FOOT SCOOTER – A device:

- 1) Weighing not more than one hundred (100) pounds;
- 2) Designed to travel on not more than three (3) wheels in contact with the ground;
- 3) With handlebars and a floorboard that the rider uses to stand on the device during operation; and,
- 4) Powered by an electric motor that is capable of powering the device with or without human propulsion at a speed not more than twenty (20) miles per hour on a paved level surface.

The term does not include a motor driven cycle, motor vehicle or motorcycle.

ELECTRIC VEHICLE CHARGING STATION (EVCS) – Equipment that connects an electric vehicle to a source of electricity for the purpose of recharging the vehicles battery(ies). Such charging stations may be utilized for, but not limited to, electric cars, hybrid vehicles, electric trucks, electric buses, golf carts and other neighborhood electric vehicles.

ELECTRIC VEHICLE CHARGING STATION, ACCESSIBLE – An EVCS which provides site features which facilitate service and equipment access by ADA qualified individuals.

ELECTRIC VEHICLE CHARGING STATION, PRIVATE – A charging station where access is restricted to a property owner, including family, friends and relatives, or to individuals with direct affiliation to a site's operations (such as executives and employees, but not to customers, visitors or general membership such as in a co-op, club or lodge). Each Private EVCS is exempt from the requirement to obtain an Improvement Location Permit

ELECTRIC VEHICLE CHARGING STATION, PUBLIC – A charging station which is available to the general public, whether free or for a fee. Each Public EVCS requires an Improvement Location Permit.

ENGINE REPAIR, SMALL - A facility where the primary business activity is the repair, maintenance and replacement of small engines, motors and other power components as well as service, repair, maintenance and reconstruction of small power devices such as, but not limited to, hand mowers, riding mowers, weed eaters, house hold generators, small appliances, hedge trimmers, electric heaters, and similar types and sized items. The facility will typically offer retail sales as a complimentary service secondary to the repair operations.

ENGINEER, PROFESSIONAL - Any person who is licensed by the State of Indiana to practice professional engineering.

ENTERTAINMENT FACILITY, COMMERCIAL – A building, structure or use of land utilized to provide for profit entertainment venues such as concerts, movies, theatrical productions, etc.

ENTRANCE DRIVE - Portion of a driveway which immediately abuts the public right-of-way or a private street.

EQUIPMENT SALES AND LEASING - The retail or wholesale sale or rental of heavy motorized vehicles or equipment, along with incidental service or maintenance such as, but not limited to construction equipment rental yards, tractor-trailers, semi-trailers, boats, buses, recreational vehicles, farm equipment and moving trailer rental.

EROSION - The removal of surface materials by the action of natural elements.

ESSENTIAL SERVICES – Services that have been viewed to be necessary to a basic standard of living and the general welfare of society, and therefore have traditionally been supplied publicly in order to ensure the broadest level of access for citizens. These services may include water, sanitation, electricity, cable, phone and fiber optics. For the purposes of the administration and enforcement of the White County Zoning Ordinance, the term essential services shall not include feeder lines installed as part of any Wind Energy Conversion System.

ETHANOL PLANT – A facility that produces ethanol.

EVENT, BARN - A building, either with or without an outdoor component, dedicated to providing a venue for weddings, anniversaries, family reunions or other large gatherings of people. Attendance is by invitation or reservation only. The facility may include a multi-use area for eating, dancing, music, entertainment or other festivities associated with celebratory or official gatherings and may also include a kitchen, bar or other amenities utilized for these types of occasions. Events open to the public without the requirement of invitation or reservation are only allowed under a Temporary Use Permit issued by the Staff and shall not be valid for more than three days; such permits may be granted no more than four (4) times per calendar year.

EVENT, GOVERNMENT – Any coordinated activity approved by any Local or State legislative body.

EVENT, SPECIAL – A one-time or infrequently occurring activity held by a private group of persons, firm, organization, association, non-profit entity or business which occurs unrelated to the principal use of the property.

EVENT, SPORTING - An athletic activity requiring skill or physical prowess and often of a competitive nature such as, but not limited to, baseball, tennis, bowling, horseshoes, hunting, bean bag and fishing.

EXCAVATION - Any act by which earth, sand, gravel, rock or any other similar material is dug into, cut, quarried, uncovered, removed, displaced, relocated or bulldozed. Shall also include the conditions resulting there from.

EXECUTIVE DIRECTOR – The individual appointed by the Area Plan Commission or his designee to direct the activities of the planning department and whose duties are established in IC 36-7-4-312.

EXPLOSIVE MANUFACTURING – The manufacturing of any chemical compound mixture or device, the primary and common purpose of which is to function by explosion with substantially simultaneous release of gas and heat, the resulting pressure being capable of producing destructive effects.

EXPLOSIVES, USE OR STORAGE – The use or storage of any chemical compound mixture or device, the primary and common purpose of which is to function by explosion with substantially simultaneous release of gas and heat, the resulting pressure being capable of producing destructive effects.

F

FACILITY, WIRELESS - A set of equipment and network components necessary to provide wireless communications service. The term does not include a wireless support structure.

FAIRGROUNDS – An outdoor area where fairs or exhibitions are held.

FAMILY - One or more persons occupying a single dwelling unit, living together as a single housekeeping unit, and sharing common living, sleeping, eating and cooking facilities. Family does not include any group living in a boarding house, hotel, club, fraternity, sorority, or rooming house.

FARM - A tract of agricultural zoned land which is devoted to agricultural operations such as forestry; the growing of crops; pasturage; the production of livestock and poultry; the growing of trees, shrubs and plants; and other recognized agricultural pursuits; and including accessory buildings essential to the operation of the farm. Accessory buildings may include barns; equipment and animal sheds; farm residences for the owner, operator or farm assistants; roadside sales structure for the sale of products of the farm; and signs displaying subject matter directly related to the name of the products of the particular farm. “Farms” shall not include industrial or commercial operations or structures, which are not directly related to agricultural production.

FARM CHEMICAL/FERTILIZER SUPPLIER – Any legal entity which stores, processes or prepares chemicals or fertilizers for the farm or agricultural community.

FARMING, MICRO – Any category of livestock; also, honey bees, which have been determined, under restricted conditions and within certain attributes as defined by Ordinance, to be suitable for raising, breeding or for personal use, in residential districts.

FEDERAL EMERGENCY MANAGEMENT AGENCY (FEMA) – An independent agency of the United States government that provides a single point of accountability for all federal emergency preparedness and mitigation and response activities

FENCE - An upright structure used to identify a boundary or to provide a means of protection, personal privacy screening or confinement, but not including hedges, shrubs, trees or other natural growth. A fence does not qualify as an enclosure.

FESTIVAL – An organized event which consists of, but is not limited to, entertainment, the sale of packaged and unpackaged food items, temporary retail vendors, sporting events, and other activities associated with carnival, bazaar or flea market operations and conducted with the approval of any local legislative body.

FILL - Any act by which earth, sand, gravel, rock or any other material is placed, pushed, dumped, pulled, transported or moved to a new location above the natural surface of the ground or on top of the stripped surface, including the conditions resulting there from. Also, the difference in elevation between a point on the original ground and a designated point of higher elevation on the final grade, or the material used to make a fill.

FIRE STATION (FIREHOUSE) – A location where fire fighting vehicles and equipment are housed and where fire fighters are on duty or called to on an as needed basis.

FIREWORKS SALES - An establishment, temporary or permanent, that sells any substance or combination of substances or articles prepared for the purpose of producing a visible or an audible effect by combustion, explosion, deflagration, or detonation, and includes blank cartridges, toy pistols, toy cannons, toy canes, or toy guns in which explosives other than toy paper caps are used, firecrackers, torpedoes, sky rockets, Roman candles, Daygo bombs, sparklers, or other fireworks of like construction, any fireworks containing any explosive or flammable compound, or any tablet or other device containing any explosive substance.

FIXTURE - The assembly that holds the lamp (bulb) in a lighting system. It includes the elements designed to give light output control, such as a reflector (mirror) or refractor (lens), the ballast, housing, and the attachment parts.

FLEA MARKET (SWAP MEET) - A market, usually held outdoors, where antiques, used/new household goods, curious, crafts, collectibles or other miscellaneous goods are sold and/or bartered.

FLOOD -- A general and temporary condition of partial or complete inundation of normally dry land areas from the overflow, the unusual and rapid accumulation, or the runoff of surface waters from any source.

FLOOD BOUNDARY AND FLOODWAY MAP (FBFM) – The official map on which the Federal Emergency Management Agency or Federal Insurance Administration has delineated both the areas of flood hazard and the floodway.

FLOOD HAZARD AREA -- A flood plain, or portion thereof, which is not adequately protected from floodwater by means of dikes, levees, reservoirs, or other works approved by the Indiana Department of Natural Resources and Federal Energy Regulation Commission (FERC).

FLOOD HAZARD BOUNDARY MAP (FHBM) -- An official map of a community, issued by the administrator, where the boundaries of the flood, mudslide (i.e., mudflow) related erosion areas having special hazards have been designated as Zones A, M, and/or E.

FLOOD INSURANCE RATE MAP (FIRM) -- The official map on which the Federal Emergency Management Agency has delineated both the areas of special flood hazards and the risk premium zones applicable to the County.

FLOOD PROFILE, REGULATORY - A longitudinal profile along the thread of a stream showing the maximum water surface elevation attained by the regulatory flood. The intent of this definition is to be consistent with the definition derived by the Indiana Department of Natural Resources.

FLOOD PROTECTION GRADE (FPG) – The elevation of the regulatory flood plus two feet at any given location in the Special Flood Hazard Area (SFHA).

FLOOD, REGULATORY – The flood having a one (1) percent probability of being equaled or exceeded in any given year, as calculated by a method and procedure which is acceptable to and approved by the Indiana Department of Natural Resources and the Federal Emergency Management Agency.

FLOODPLAIN – The channel proper and the areas adjoining any wetland, lake or watercourse, which have been or hereafter may be covered by the regulatory flood. The floodplain includes both the floodway and the floodway fringe districts.

FLOODWAY – The channel of a river or stream and those portions of the floodplains adjoining the channel which are reasonably required to efficiently carry and discharge the peak flood flow of the regulatory flood of any river or stream.

FLOODWAY FRINGE – Those portions of the floodplain lying outside the floodway.

FLOOR AREA, GROSS (GSF) - The total horizontal areas of the one (1) or several floors of a building or portion thereof devoted to a particular use, including accessory storage areas located within selling or working space such as counters, racks, or closets and any basement floor area devoted to retailing activities, to the production or processing of goods or to offices; provided, however, gross floor area shall not include that area devoted entirely and permanently to storage purposes, parking and loading facilities, or space used for restrooms, utilities, stairwells or elevator shafts.

FLOOR AREA, NET - The total area, computed on a horizontal plane, used for a particular business category; exclusive of entrances, hallways, stairs and other accessory areas used for ingress or egress.

FOOT-CANDLE – A unit of illumination equal to the illumination at all points that are one (1) foot from a uniform point source of one (1) candle of power.

FOUNDATION - The supporting member of a wall or structure.

FOUNDATION SIDING or SKIRTING – A type of wainscoting constructed of fire and weather resistant material, such as aluminum, treated pressed wood or other approved materials, enclosing the entire undercarriage of the manufactured or mobile home.

FOUNDRY PLANT – A facility where the molding, casting and/or shaping of metals occurs using heat and/or compression.

FULL CUTOFF - A light fixture, which prevents distribution of light above a horizontal plane passing through the lowest point of the bulb or lens, diffuser, reflective enclosure, or other parts intended to distribute light.

FUNERAL HOME OR MORTUARY - An establishment engaged in undertaking services such as preparing the human dead for burial, and arranging and managing funeral services before burial or cremation.

G

GARAGE - A structure, building or part thereof used for the storage, parking, or servicing/repair of Class I and Class II motor vehicles owned by and registered to the property owner or occupant of the lot on which it is situated, including carports. Such use may include storage of non-commercial, personal effects or items.

GARAGE, ATTACHED - A portion of the principal building, used or designed to be used for a garage.

GARAGE, DETACHED An accessory building, or part thereof, used or designed to be used for a garage.

GARAGE/YARD SALE - Also called Rummage Sale, Lawn Sale, Attic Sale, Moving Sale, Garbage Sale, Thrift Sale or Junk Sale. A private or public sale of six (6) or more items of personal property, the sale of which is conducted within a residence, garage, or other accessory building, or immediately outside of such building, and which the owner or occupier of such structure conducts. The sale may include one or more families.

Also, a sale conducted by a non-profit organization of miscellaneous goods, personal property or other articles generally contributed by donors in an effort to raise money for a cause, program, another organization or the organization itself.

GASOLINE SERVICE STATION - An establishment where gasoline and other petroleum products are sold as the principal use of the property. Retail items typically found in a convenience market including prepackaged food items and tangible consumer goods, primarily for self-service by the consumer can be sold. Hot beverages, fountain-type beverages, and pastries may be included in the food items offered for sale, but food items that are prepared or individually proportioned on the premises shall be prohibited. Light maintenance activities such as lubrication, and minor repairs may also be provided if incidental to such principal use.

GO-KART FACILITY – An entertainment facility that uses a small low motor vehicle with four wheels and an open framework for recreational racing on a track.

GOLF COURSE - A tract of land laid out with at least nine (9) holes for playing a game of golf and improved with tees, greens, fairways and hazards. A golf course may include a driving range, pitch and putt area, a clubhouse and shelters as accessory uses.

GOVERNMENT BUILDING – See Building, Government

GOVERNMENT BUILDING DEPARTMENT OR AGENCY – See Building, Department or Agency

GRADE – The elevation established for the purpose of regulating the number of stories and the height of buildings. Grade shall be the mean level of the finished surface of the ground adjacent to the exterior walls of the building.

GRAIN ELEVATOR – A building(s) for elevating, storing, discharging, and sometimes processing grain including related uses or structures.

GRANDSTAND - A usually roofed stand for spectators at a stadium or racetrack.

GREENHOUSE, COMMERCIAL - A greenhouse used for the growing of plants, all or part of which are sold at retail or wholesale.

GREENHOUSE, NON-COMMERCIAL – A small structure where residents grow flowers, shrubs, vegetables and the like for their own private use.

GREENSPACE AREA – That portion of the front yard of a lot that is immediately adjacent and parallel to the right-of-way of US 24 and all county roads within the identified boundaries and from the right-of-way line.

GROCERY STORE OR SUPERMARKET – Stores where most of the floor area is devoted to the sale of food products for home preparation and consumption, which typically also offer other home care and personal care products, and which are substantially larger and carry a broader range of merchandise than convenience stores.

GROUP HOME – A facility for persons who are handicapped, mentally retarded or developmentally disabled, or who because of age or other physical, psychological, or social disabilities, or by reason of relational circumstances may require the protection of a group home setting to care for themselves or to facilitate the transition to a functioning member of society. Refer also to IC 12-7-2-166 and 167.

GUARD SHACKS - A structure built in compliance with all building codes of White County and located on private property for the purpose of manually or electronically monitoring pedestrian or vehicular traffic and promoting security substantially impeding or restricting ingress or egress; provided, however, a guard shack shall not be designed or used for sleeping or living purposes.

GUEST HOUSE – A use of room or rooms within an “accessory building” used for the occasional housing of non-paying guests or occupants of the principal building and not for permanent occupancy by others.

GUN SALES – A place where general retail sales of gun and firearm associated items are bought and sold. All developmental standards for retail sales must be met. A gun smith may be active on-site and perform gun-smith activities. The business and its site must comply with any federal, state or local laws, statutes or regulations in addition to Zoning Ordinance requirements. A shooting range is not included as a permissible use without a Special Exception having been granted.

GUN SMITH – A place where a person provides small firearms related services such as repairs, modifications, designs and building of small firearms along with firearm testing. Sales derived from providing services or selling of firearms individually designed and built by the person on-site are permissible. General retail sales, a retail establishment or a retail sales floor where general gun and firearms sales occur is not permitted. The business and its site must comply with any federal, state or local laws, statutes, and regulations in addition to Zoning Ordinance requirements. A shooting range is not included as a permissible use without a Special Exception having been granted.

H

HARDSHIP - A perceived difficulty with regard to one's ability to improve land as a result of the application of the development standards of this Ordinance.

HATCHERY – A place where eggs, especially those of fish or poultry, are hatched.

HATCHERY, COMMERCIAL – A business which conducts egg hatching, typically of fish and poultry, and which does not conduct retail sales as part of its business

HAZARDOUS WASTE – A waste with properties that make it dangerous or potentially harmful to human health or the environment.

HAZARDOUS WASTE LANDFILL/FACILITY – All structures, other appurtenances, and improvements on the land used for treating, storing, or disposing of hazardous waste, including all operations or storage areas, diked overflow, or emergency spillway areas. A hazardous waste disposal facility may consist of several treatment, storage, or disposal operational units; it includes all areas where hazardous waste may be received, stored, handled, or processed.

HEALTH AND FITNESS CENTER – A facility which provides exercise and wellness opportunities for the general public.

HEALTH CENTER, PUBLIC - A facility primarily utilized by a health unit for providing public health services including related facilities such as laboratories, clinics and administrative offices operated in connection therewith.

HEIGHT, MAXIMUM - Maximum height is measured from grade level to the highest point of the structure.

HELIPORT - A place for helicopters to land and take off.

HOME OCCUPATION – Any activity performed for monetary gain in or directed from a dwelling unit by one (1) or more residents of that dwelling unit which is located in a residential zone or on a property with a dwelling unit as its primary use, provided that such activity meets the requirements set forth in Chapter 3, Specific Use Requirements and Performance Standards, Section 3.1, Home Occupations.

HOSPITAL - An institution licensed by the State Department of Health to provide health services for the sick or injured, and which may include related facilities such as laboratories, out-patient departments, training facilities, central service facilities, and staff offices which are an integral part of the facility; provided such institution is operated by, or treatment is given under direct supervision of a licensed physician. Types of hospitals include general, mental, chronic disease and allied special hospitals such as cardiac, contagious disease, maternity, orthopedic, cancer, and the like.

HOTEL - A commercial building or buildings which, for compensation, offer transient lodging to the public consisting of a bedroom, bathroom and closet space, often times including a work area or small meeting room. The facility may provide additional services, such as a restaurant, lounge, meeting room(s), convention room(s) and/or common recreation facilities. A hotel offers short-term rentals which last less than 30 days. The majority of rooms have access directly to a hallway. Use as an apartment or other type dwelling unit is prohibited.

HUMANE – An action which minimizes the infliction of pain and discomfort and is characterized by compassion, kindness and respect.



IMPROVEMENT - Any alteration to the land or other physical constructions associated with subdivision and building site development.

IMPROVEMENT LOCATION PERMIT – A permit issued for zoning and land use compliance verification purposes.

IMPROVEMENT, PUBLIC - Any drainage ditch, roadway, sidewalk, curb, tree, lawn, off-street parking area, main, or other facility for which the local or state government may ultimately assume the responsibility for maintenance and/or operation, or which may affect an improvement for which local or state government responsibility is established. All such improvements shall require performance guarantee.

IMPROVEMENT, TEMPORARY - Improvements built and maintained by a sub divider during construction of the subdivision and which may become permanent prior to release of the performance guarantee.

INCINERATOR - A furnace or a container for burning waste materials.

INDIVIDUAL SEWAGE DISPOSAL SYSTEM - A septic tank, seepage tile, sewage disposal system, or any other approved sewage treatment device designed for use in a limited area as approved by the White County Health Department.

INDUSTRIAL PARK - A planned, coordinated development of a tract of land with two (2) or more separate industrial buildings. Such development is planned, designed, constructed, and managed on an integrated and coordinated basis with special attention given to on-site vehicular circulation, parking, utility needs, building design, orientation and open space.

INDUSTRIAL USE - A use involving the manufacture, procession, assembly, or storage of equipment, raw materials, or manufactured products which require an industrial zoning classification of I-1 or I-2 as stipulated by Appendix A: Official Schedule of Uses.

INDUSTRIAL WASTE FACILITY – A facility used for the storage, transportation, reclamation or disposal of any waste classified as hazardous or toxic by the United States Environmental Protection Agency.

INDUSTRIALIZED RESIDENTIAL STRUCTURE – See Modular Home.

INFORMATION CENTER, VISITOR/TOURIST – A physical location, often simply called an “Information Center”, that provides visitors and tourists with information, maps, flyers, brochures or other similar materials for the purposes of advancing local places of interest or businesses which provide unique services or products which tourists or visitors might find desirable. Identification and information on lodging, camp sites, landmarks and parks are commonly available. Guided tours are often coordinated at these locations and the sites frequently use film or other electronic media formats to present the community and its unique offerings. Educational exhibits and artifact displays are common.

INFRASTRUCTURE - The services and facilities necessary in a community, including but not limited to sewers, water systems, streets, utilities and drainage services.

INGRESS - Access or entry point.

INSTITUTION - Any facility maintained or conducted by a group of persons, a firm, association, non-profit entity, corporation, or government body (i.e. buildings and land designed to aid individuals in need of mental, therapeutic and rehabilitative counseling or buildings and land designed to aid individuals in educational, religious, charitable or other such pursuits).

INTEGRATED CENTER - One or more buildings occupying a site under one ownership or management, containing a number of individual, unrelated and separately operated uses each with their own outside entrance opening to the outdoors or a common concourse. The building or buildings of an integrated center share common site facilities and services such as driveway entrances and exits, parking areas, truck loading, maintenance, sewer and water utilities and similar common facilities and services. A building on an out lot, which is physically separated from the other uses in an integrated center, by curbs and/or landscaping, and which contains its full requirement of parking, but which shares

driveway entrances and exits with other uses, is not part of that integrated center. An office building is not an integrated center. Shopping Centers, Malls, Shopping Malls, Outlets Malls and Strip Malls are retail types of Integrated Centers

INTERESTED PERSON - Someone having an interest in land affected by a given zoning decision as determined by the written rules of either the Area Plan Commission or the Board of Zoning Appeals.

INTERNET SELLING ESTABLISHMENT/E-BAY STORE – A business which purchases items from businesses and/or individuals and/or accepts consignment of items (either physically or not) and sells them through marketing channels available on the internet as their primary function. There may or may not be on-site retail operations. There will normally be stocking and storage of merchandise available for sale.

J

JAIL – A place for the confinement of persons in lawful detention, especially persons awaiting trial under local jurisdiction.

JUNKYARD - Any place at which personal property is or may be salvaged for reuse, resale or reduction or similar disposition and is owned, possessed, collected, accumulated, dismantled, or assorted. Including but not limited to, used or salvaged base metal or metals, their compounds or combinations, used or salvaged rope, bags, paper, rags, glass, rubber, lumber, millwork, brick and similar property except animal matter; and used motor vehicles, machinery or equipment which is used, owned or possessed for the purpose of wrecking or salvaging parts there from.

K

KENNEL, COMMERCIAL – An establishment whose primary purpose is to breed, board or train domestic animals not owned by the owner or occupant of the property.

KENNEL, PRIVATE - Any lot or premises where the care of six (6) or more domestic animals over six (6) months of age belonging to the owner of the principal use, are kept for purposes of show, hunting, or personal enjoyment as pets.

L

LABORATORY, COMMERCIAL – A facility devoted to experimental study, testing or analysis. Manufacturing, assembly or packaging of products shall not be conducted within this facility.

LABORATORY, MEDICAL OR DENTAL - A facility for scientific laboratory analysis of medical or dental resources. The scientific analysis is generally performed for an outside customer. This category includes medical or veterinary laboratories for the analysis of blood, tissue, or other human medical or animal products. Forensic laboratories for analysis of evidence in support of law enforcement agencies would also be included in this category.

LABORATORY, RESEARCH ACTIVITY AND TESTING - Research, development and testing related to such fields as chemicals, pharmaceutical, medical, electrical, transportation and engineering. All research, testing and development, whether conducted within or outside of buildings shall create no noise, smoke, glare, vibration or odor which can be detected outside of the buildings or property line. A research and testing laboratory shall mean a building in which scientific research, investigation, testing or experimentation is conducted, but not including the manufacturing or sale of products, except as incidental and accessory to the main purpose of the laboratory.

LAND USE AMENITY - Incidental structures such as, but not limited to, gazebos, picnic tables, benches, patio furniture, decks, pergolas or other similar structures used to increase the function and desirability of a principal use and not included elsewhere.

LANDFILL - The burial of non-hazardous, non-radioactive and non-medical farm, residential, institutional, commercial, or industrial waste, usually after the waste has been compacted.

LANDFILL, SANITARY - An engineered land burial facility for the disposal of solid waste which is so located, designed, constructed, and operated to contain and isolate the solid waste so that it does not pose a substantial present or potential hazard to human health or the environment.

LANDOWNER - The legal or beneficial owner or owners of land.

LANDOWNER, NON-PARTICIPATING (See “NON-PARTICIPATING LANDOWNER”)

LANDOWNER, PARTICIPATING (See “PARTICIPATING LANDOWNER”)

LANDSCAPE CONTRACTOR - Any person, firm, association, syndicate, partnership, realtor or corporation engaged in the business of accepting orders or contracts, either as a general contractor or subcontractor for the planning, design and installation of landscaping for uses. A landscape contractor may provide a retail establishment for the sale of products used for landscaping or yard decorating or home decorating purposes in conjunction with their landscape services.

LANDSCAPING – Any act whose purpose is to modify the visible features of an area of land.

LAUNDRY FACILITY, SELF-SERVICE – A facility where patrons wash, dry, or dry clean clothing or other fabrics in machines operated by the patron.

LAUNDRY OR DRY-CLEANING FACILITY - An establishment or business maintained for the pickup and delivery of dry cleaning and/or laundry with or without the maintenance or operation of any laundry or dry-cleaning equipment or machinery on the premises.

LAYDOWN YARD, TEMPORARY – An outside area used to support construction activity where tools, materials, equipment, parking, storage units, construction trailers or other similar items are temporarily stored or placed for a period of 12 months or less.

LAYDOWN YARD, PERMANENT - An outside area used to support construction activity where tools, materials, equipment, parking, storage units, construction trailers or other similar items are temporarily stored or placed for a period of more than 12 months.

LEASE LINE - Any perimeter boundary line of an area which is a portion of a legal parcel, lot or tract of land, which area is leased to a third party and which boundaries are defined by a legal instrument.

LIBRARY – A place in which literary, musical, artistic or reference materials (such as books, manuscripts, recordings, films, etc.) are kept for use, but generally not for sale.

LICENSE TO ENTER - A right held by a public or private utility or government entity for temporary access on privately owned property to perform maintenance or upgrades to utility infra-structure or road/street bordering amenities.

LIVESTOCK - Generally accepted outdoor farm animals (i.e., cows, goats, horses, pigs, barnyard fowl, etc.) or any animal that is commonly used as a protein source. Livestock does not include domestic animals..

LIVING SPACE - That portion of the floor area constructed, completed and usable for living purposes with normal living facilities which includes sleeping, dining, cooking, working, entertainment, common space linking rooms, areas for personal hygiene or combination thereof. Floor area or portion thereof used only for storage purposes and not equipped for the facilities mentioned above shall not be considered living space. No area in an attached garage shall be considered living space (for the purpose of meeting minimum living space requirements)

LOADING SPACES/BERTHS - The off-street area required for the receipt or distribution by vehicles of material or merchandise.

LOT - A single recorded tract or plot, which is the smallest unit of a residential, commercial or industrial subdivision or other parcel of land. A lot serves as a unit for the purpose, whether immediate or future, of transfer of ownership, or lease. This also includes an area of land created by a subdivision in accordance with this Ordinance or any prior subdivision ordinance.

LOT AREA – The area of the horizontal plane of a lot bounded by the vertical planes of the front, side and rear lot lines. Easements are considered to be part of the lot area. The lot area is exclusive of right-of-way and may not be covered by water.

LOT, CORNER – A lot which has street fronts on two or more adjoining lot lines.

**ILLUSTRATION OF THE BASIC
TYPES OF LOTS**

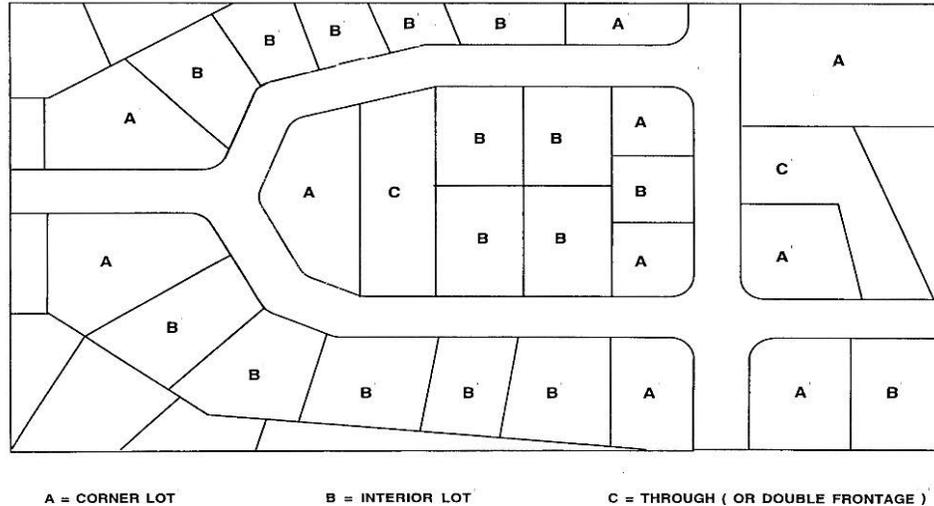

LOT COVERAGE - The total ground area of a lot usually expressed as a percentage of the lot area that is covered, occupied or enclosed by principal and accessory buildings and structures.

LOT, DEPTH OF - The mean horizontal distance between the front lot line and the rear lot line of a lot, measured in the general direction of the side lot line.

LOT, FLAG - A lot not fronting or abutting a public roadway and where access to the public roadway is limited to a narrow private right-of-way.

LOT FRONTAGE - The front of a lot shall be construed to be the portion nearest the street right-of-way. For the purposes of determining yard requirements on corner lots and through lots, all sides of a lot adjacent to street right-of-way shall be considered frontage, and yards shall be provided under "yards" in this Section.

LOT, INTERIOR - A lot other than a corner lot or a through lot.

LOT LINE, FRONT - A line separating a lot from a street. Any lot line, which abuts a street, shall be considered a front lot line; provided, however, for lots located in a lake or river area, the only front lot lines for the lot shall be the lot lines marking the boundary between the lot and the lake or river area. Lake or river area shall be determined at the discretion of the Executive Director.

LOT LINE, OPPOSITE – The side property line on the opposite side of the dwelling from the zero lot line.

LOT LINE, REAR - A lot line which is opposite and most distant from the front lot line and, in the case of an irregular or triangular-shaped lot, a line within the lot, parallel to and at the maximum distance from the front lot line.

LOT LINE, SIDE - Any lot boundary line not a front lot line or a rear lot line.

LOT, MINIMUM AREA OF - The smallest lot area established by this Ordinance on which a use or structure may be located in a particular district, and which does not include any street right-of-way.

LOT, NONCONFORMING - A lot, the area, dimension or location of which was lawful prior to the adoption, revision or amendment of this zoning Ordinance but which fails by reason of the adoption, revision or amendment to conform to the present requirement of the zoning district.

LOT OF RECORD - A lot which is part of a subdivision, the map of which has been recorded in the Office of the County Recorder of White County, Indiana; or a parcel of land, the deed to which has been recorded in the Office of the County Recorder of White County, Indiana, prior to the date of passage of this Section of the Ordinance.

LOT, SALES - Premises on which new or used passenger cars, recreational vehicles, boats, commercial vehicles, farm implements, trailers or other vehicles, or manufactured homes are displayed in the open for sale or trade. All vehicles must be in operable condition.

LOT, THROUGH (DOUBLE FRONTAGE) – A lot which has more than one street front on opposite ends of the parcel.

LOT WIDTH - The dimension of a lot, measured between side lot lines on the building line.

M

MANEUVERING AISLE - A maneuvering space, which serves two or more parking spaces, such as the area between two rows of parking spaces and/or the driveway leading to those spaces.

MANEUVERING SPACE - An open space in a parking area, which is immediately adjacent to a parking space; is used for and/or is necessary for turning, backing or driving forward a motor vehicle into said parking space; but is not used for the parking or storage of motor vehicles.

MANUFACTURED HOME – As defined in IC 9-13-2-96, a manufactured home is assembled in a factory; bears a seal certifying that it was built in compliance with the federal manufactured housing construction and safety standards law (42 U.S.C. 5401 et seq.); is designed to be transported from the factory to another site in one (1) or more units; is suitable for use as a dwelling in any season; and is more than thirty-five (35) feet long. All manufactured homes shall be in compliance with the federal manufactured Housing Construction and Safety Standards Law of 1974 (42 U.S.C. 5401 et seq).

MANUFACTURED HOME PARK OR SUBDIVISION – A manufactured home park or subdivision for which the construction of facilities for servicing the lots on which the manufactured homes are to be affixed (including at a minimum, the installation of utilities, the construction of streets, and either final site grading or the pouring of concrete pads) is completed on or after the effective date of this ordinance.

MANUFACTURED HOME PARK OR SUBDIVISION, EXISTING – A manufactured home park or subdivision for which the construction of facilities for servicing the lots upon which the manufactured homes are to be affixed (at a minimum, the installation of utilities, the construction of streets, and either final site grading or the pouring of concrete pads) is completed before the effective date of this ordinance.

MANUFACTURED HOME PARK OR SUBDIVISION, EXPANSION – The preparation of additional sites by the construction of new facilities for servicing the lots on which manufacturing homes are to be affixed (including the installation of utilities, the construction of streets, and either final site grading or the pouring of concrete pads).

MANUFACTURED HOME SALES – The sale of dwelling units designed and built in a factory and installed as a permanent residence, which bears a seal certifying that it was built in compliance with the National Manufactured Home Construction and Safety Standards Act (1974 U.S.C. 5401 et seq.).

MANUFACTURED HOME, SECTION - A unit of a manufactured home at least ten (10) feet in width and thirty (30) feet in length.

MANUFACTURED/MOBILE HOME DWELLING – A Type II Manufactured or Mobile Home which is used in accordance to Subsection 3.4.1 of the White County Indiana Zoning and Subdivision Control Ordinances.

MANUFACTURED/MOBILE HOME OFFICE – A Manufactured or Mobile Home which is used in accordance to Subsection 4.4.1 C. of the White County Indiana Zoning and Subdivision Control Ordinances.

MANUFACTURED/MOBILE HOME OFFICE, PERMANENT – A manufactured or mobile home utilized as a permanent office by a public or private enterprise.

MANUFACTURED HOUSING CONSTRUCTION AND SAFETY STANDARDS CODES -- Title VI of the 1974 Housing and Community Development Act (42 U.S.C 5401 et sequential), as amended (previously known as the federal Mobile Home Construction and Safety Act), rules and regulations adopted there under (including information supplied by the home manufacturer, which has been stamped and approved by a Design Approval Primary Inspection Agency, an agent of the U.S. Department of Housing and Urban Development pursuant to HUD rules), and regulations and interpretations of said code by the Indiana Administrative Building Council; all of which became effective for mobile/manufactured home construction on June 15, 1976.

MANUFACTURING – The process of making, assembling, adding improvements to, or fabricating raw materials by hand, machinery or the combination thereof into finished or semi-finished parts or products.

MANUFACTURING, EXTRACTIVE NON-URBAN - Any mining, quarrying, processing, storing, separating, cleaning or marketing of any material natural resource, excluding gas and oil, outside an urban area.

MANUFACTURING, EXTRACTIVE URBAN – Any mining, quarrying, processing, storing, separating, cleaning or marketing of any material natural resource, excluding gas and oil, within an urban area.

MANUFACTURING, HEAVY - A use engaged in the processing and manufacturing of materials or products predominately from extracted or raw materials, or a use engaged in storage of, or manufacturing processes using flammable or explosive materials, or storage or manufacturing processes that potentially involve hazardous or commonly recognized offensive conditions which would generate objectionable or hazardous elements such as: heat, smoke, odor, vibration, water pollution, electromagnetic disturbances, radiation or dust. Such uses will often have outside storage of materials, equipment and products and will commonly have on-site OEM or retail sales staff and facilities and/or showroom to support the promotion of their products and services.

MANUFACTURING, LIGHT - Manufacturing or other industrial uses which are controlled operations; relatively clean, quiet and free of objectionable or hazardous elements such as smoke, noise, odor, or dust; operating and storing entirely within enclosed structures; and generating little industrial traffic and no nuisance. Such uses will commonly have on-site OEM or retail sales staff and facilities and/or showroom to support the promotion of their products and services.

MARINA – Waterfront establishments whose business is offering the sale or rental of boats and marine sporting equipment and the servicing, repair, or storage of same. Such establishments may also provide travel lift services, slip rental, gasoline, sanitary pump out service and food, drink and transient lodging accommodations.

MASSAGE – The rubbing or kneading of muscles and joints of the body with hands, arms, elbows or feet for the purpose of relieving stress, increasing circulation, relieving muscle and/or joint stiffness and/or pain or relaxing muscles without the result of sexual arousal or the purpose of sexual stimulation of any kind. The process sometimes includes the use of mechanical or electrical devices and may utilize supplementary aids such as oils, lotions, ointments, liniments, creams, rubbing alcohol or other similar preparatory products.

MASSAGE PARLOR – An establishment whose primary purpose is to provide massage services as defined herein and whose employees are state licensed to provide such services. The establishment must generate at least 75% of its revenue from massage services.

MECHANICAL RIDES OR ATTRACTIONS – A device ridden or operated for amusement or excitement driven by some type of machine or tool.

MEDICAL CLINIC – An establishment where patients, who are not lodged over-night, are admitted for examination, testing, and/or treatment by a group of physicians, dentists, optometrists, chiropractors or other health care professionals.

MEDICAL EMERGENCY/IMMEDIATE CARE FACILITY - A facility for the examination and outpatient treatment of “walk-in” human patients, which may be open 24 hours per day.

MEDICAL, MENTAL HEALTH FACILITY (OR PSYCHIATRIC HOSPITAL) - A facility or institution for diagnosing, treating, caring for, or counseling people requiring mental health services in confinement.

MEDICAL OFFICE – An entity or establishment where patients, who are not lodged over-night, are admitted for examination, testing, and/or treatment by a single physician, dentist, optometrist, chiropractor or other health care professional.

METAL FORGING PLANT – See Foundry Plant.

METEOROLOGICAL TOWER – Towers which are erected primarily to measure wind speed and direction plus other data, excluding towers and equipment used by airports, the Indiana Department of Transportation, or other similar applications to monitor weather conditions.

METEOROLOGICAL TOWER, OPERATIONAL SUPPORT – Towers which are erected primarily to measure wind speed and direction plus other data in support of an operating WECS, excluding towers and equipment used by airports, the Indiana Department of Transportation, or other similar applications to monitor weather conditions.

MINERAL EXTRACTION - Mining or quarrying; and removal of earth materials.

MINIATURE GOLF FACILITY - Typically a theme-oriented recreational facility, usually comprised of nine or 18 putting greens, each with a “cup” or “hole”, where patrons in groups of one to four pay a fee to move in consecutive order from the first hole to the last.

MINI-BARN – See the definition for SHED.

MIXED USE - A single building containing more than one (1) type of land use or a single development of more than one (1) building and use, where the different types of land uses are in close proximity, planned as a unified complementary whole, and functionally integrated to the use of shared vehicular and pedestrian access and parking areas.

MOBILE HOME - Any vehicle more than thirty-two (32) feet in length designed by the manufacturer or maker with hitch and undercarriage to permit its being used as a conveyance upon public streets and highways and so designed, constructed or reconstructed as will permit the vehicle to be used as a dwelling and not qualifying under the definition of manufactured home or recreational vehicle.

MOBILE HOME, OFFICE – A mobile home used temporarily during a period of construction and development.

MODEL HOME OR APARTMENT- A dwelling unit used temporarily for display purposes which typifies the type of units that will be constructed in the subdivision in which the dwelling unit is located, and may contain a temporary sales office for the residential development in which the dwelling unit is located.

MOBILE HOME PARK - An area of land upon which two or more Mobile Homes are harbored for the purpose of being occupied either free charge or in consideration of the payment of rental for the Mobile Home or the site upon which it rests; and within which area a Mobile Home may be supported either by its wheels or by a foundation of any sort.

MOBILE HOME SPACE -- A plot of ground within a mobile home park designated for the accommodation of one mobile home.

MOBILE HOME STAND -- That part of an individual mobile home space which has been reserved for the placement of the mobile home, appurtenant structures, or additions.

MOBILE HOME SUBDIVISION – A “subdivision” as defined by the state Subdivision Control Act, being Act 288 of the Public Acts of 1967, as amended, which has been expressly established for the sole purpose of selling lots on which mobile homes may be used and occupied for residential purposes, and which has been established in full compliance with all applicable provisions of the aforementioned Act and of all other applicable state and county regulations.

MODULAR HOME - A factory-built home, other than a manufactured home, which meets all of the following requirements: is designed only for erection or installation on a site-built permanent foundation; is not designed to be moved once so erected or installed; is designed and manufactured to comply with a nationally recognized model building code or an equivalent local code, or with a state or local modular building code recognized as generally equivalent to building codes for site-built housing; or to the manufacturer’s knowledge, is not intended to be used other than on a site-built permanent foundation.

MONUMENT, SURVEY - Any permanent marker either of stone, concrete, galvanized iron pipe, or iron or steel rods, used to identify the boundary lines of any tract, parcel, lot or street lines.

MONUMENT WORKS AND STONE CUTTING – A sculpture created by using power tools such as compressed-air chisels, abrasive spinners and angle grinders on stone from the earth.

MOTEL - A commercial building or buildings devoted to the provision of sleeping accommodations for automobile transients consisting of a bedroom, bathroom, closet space, and convenient access to a parking space. Motels may include other accessory uses such as a restaurant, lounge, swimming pool, meeting room and the like. A motel offers short-term rentals which last less than 30 days. The majority of rooms have access directly to the outdoors with the facility designed for motorists. Use as an apartment or other type dwelling unit is prohibited.

MOTOR VEHICLE - An automobile, truck, motorcycle and any other vehicle propelled or driven otherwise than by muscular power, but does not include the cars of electric or steam railways, or other motor vehicles running only upon rails, or a motorized snow vehicle, traction engine, farm tractor, self-propelled implement of husbandry or road building machine.

MOTOR VEHICLE, INOPERABLE - A vehicle from which the engine, transmission, or differential has been removed or that is otherwise partially dismantled or inoperable and left on public property, or; a vehicle that is at least three (3) model years old, is mechanically inoperable, and is left on private property continuously in a location visible from public property for more than twenty (20) days.

MOTORCYCLE SALES - The use of any building or portion thereof, or other premises or portion thereof, for the display, sale, rental, or lease of new motorcycles, or used motorcycles as an ancillary use of a zoning lot, and any warranty repair work and other repair service conducted as an accessory use.

MUSEUM/GALLERY – A building in which objects of historical, scientific, artistic or cultural interest are stored and exhibited and which may include retail, food service or other offerings complimentary to promoting the museum activities. In no case may the museum floor space be less than 50% of the total floor space of the facility/facilities including accessory structures.

N

NAMEPLATE: A flat piece of wood, plastic or metal used solely for the purpose of identifying the name of a person, company or activity (such as occupation) or to identify a particular building. Name plates may be no larger than three (3) square feet. Larger nameplates, if warranted due to the number of name characters or which are remotely located (such as at the top of a building or on a building a significant distance from a typical, public viewing point, may be installed upon written authorization from the Executive Director or upon approval from the Area Board of Zoning Appeals.

NATURAL RESOURCES, DEPARTMENT OF -- The Department of Natural Resources of the State of Indiana.

NEIGHBORHOOD FACILITY – A building utilized for multiple purposes and created for the general benefit and welfare of the local community. This facility will utilize portions of the facility for multiple uses such as office rentals, museum type exhibitions, theatrical and musical performances, recreational purposes, banquet facilities and as a location for minor conventions, small trade shows, community meetings, social or cultural events, local festivities such as parades, festivals, carnivals, bazaars, etc. These locations would also be suitable for YMCA, YWCA, Boy Scout or Girl Scout facilities.

NEON - Irregularly bent or shaped glass tubing containing gaseous neon, which glows when an electrical current is applied.

NET-METERING - Net-metered customers are credited for net excess generation, wherein no cash is given to the owner of the wind turbine.

NEWSPAPER PUBLISHING - The trade, profession, or activity of preparing and producing news material in printed or electronic form for distribution to the public

NEWSPAPER STAND - A temporary structure, manned by a vendor that sells newspapers, magazines, other periodicals. Can also include a permanent stand where money is deposited into a machine to receive a paper.

NON-PARTICIPATING LANDOWNER – A person(s) or entity who has NOT entered into any final contractual agreement with a Wind Energy Conversion System (WECS) or Commercial Solar Energy System (CES) company, entity or person(s) (i) for the purposes of developing a WECS and/or CES Project on or near such person(s) or entity's land and/or (ii) to receive certain economic benefits to accrue from the operation of the WECS or CES Project.

NON-PARTICIPATING PROPERTY – A lot or parcel of real property that is not owned by a project owner and, with respect to which:

- 1) the project owner does not seek to install or locate one (1) or more CSE systems or other facilities related to a CSE system project (including power lines, temporary or permanent access roads, or other temporary or permanent infrastructure); or,
- 2) the owner of the property does not consent to having one (1) or more CSE systems or other facilities related to a CSE system project (including power lines, temporary or permanent access roads, or other temporary or permanent infrastructure) installed or located; or, to otherwise enter into a lease or any other agreement with the project owner of use of all or part of the property in connection to a CSE systems project.

NON-PROFIT/CHARITABLE ORGANIZATION – A tax-exempt organization which uses money earned from fundraising activities or donations to further a charitable, scientific, religious, literary, educational or public safety purpose or other activity serving the public interest or common good.

NOXIOUS MATTER OR MATERIALS -- That which is capable of causing injury to living organisms by chemical reaction or is capable of causing detrimental effects upon the physical or economic well-being of individuals.

NURSERY, HORTICULTURE – Land, building(s), structure(s), or any combination thereof used for the storage, cultivation, transplanting of live trees, shrubs, flowers and other plants including products used for gardening or landscaping. The business may operate as a wholesale or retail business or both.

NURSING HOME – Any institution, whether operated for profit or not, including a place operated by a county or municipality, which undertakes through its ownership or management to provide for a period exceeding 24 hours, nursing care, personal care, or custodial care for three or more persons not related to the owner or manager by blood or marriage, who by reason of illness, physical infirmity, or advanced age require such services, but, in contradistinction to a hospital, does not include any place providing care or treatment primarily for the acutely ill.



OCCUPANCY - The residing of an individual overnight in a dwelling unit, or the installation, storage or use of equipment, merchandise or machinery on the premises or in any public, commercial or industrial building and/or the use of land, building or structures. A change in occupancy is not intended to include a change of tenants or proprietors.

OCCUPANCY PERMIT - A required permit allowing occupancy of a building or structure after it has been determined that the building or structure meets all the requirements of applicable Ordinances.

OFFICE BUILDING - A building in which the majority of gross leasable area is devoted to conducting a mix use of professional, institutional, government or administrative services or affairs and compartmentalized in a manner so that each such activity or entity has public entrances in the interior of the building

OFFICE RESEARCH PARK - A large tract of land that has been planned, developed and operated as an integrated facility for a number of separate office buildings and supporting ancillary uses with special attention to circulation, parking, utility needs, aesthetics, and compatibility.

OFF-SITE (OFF-PREMISES) - Outside the limits of the area encompassed by the tract area or the parcel of record on which the activity is conducted.

ONE AND TWO-FAMILY DWELLING ORDINANCE, INDIANA - The nationally recognized model building Ordinance adopted by the Indiana Department of Fire Prevention and Building Safety as mandated by Public Law 360, Act of 1971, and which includes those supplements and amendments promulgated by this agency.

ON-SITE - Located inside the property lines of the parcel in question.

OPEN SPACE - The total horizontal area of a lot excluding the building area but including parking areas and recreational areas, provided, however, in Residential Districts, said open space may include the usable roof area within the project which has been improved for outdoor use of occupants, plus one-half of that space, such as balconies, which may be open on its sides but not open above to the sky.

OPEN SPACE, COMMON - Land within or related to a development, not individually owned or dedicated for public use, that is designed and intended for the common use or enjoyment of the residents of the development and may include such complementary structures and improvements as necessary and appropriate.

ORCHARD/VINEYARD - A group of fruit or nut trees, either small and diverse and grown for home use, or large and uniform (i.e., of one variety) and cultivated for revenue. Such a collection must be planted, managed, and renewed by the householder or farmer and should not be confused with a naturally occurring grove. Orchards include vineyards.

ORDINANCE – A law or regulation set forth and adopted by a governmental authority, usually a city or county.

OUTDOOR LIGHT (FIXTURE) - A light fixture located outside or intended to be viewed from the outside.

OUTDOOR STORAGE - The keeping, in an unroofed area, of any goods, material, merchandise, or vehicles in the same place for more than twenty-four (24) hours.

OVERLAY DISTRICT – A district established by ordinance to prescribe special regulations to be applied to a site in combination with the underlying or base district.

OWNER - A, person, firm, association, syndicate, partnership, corporation, or any other legal entity recorded as such on official records, and including a duly authorized agent or notary, a purchaser, a devisee, judiciary, and person having a vested or contingent interest in the property in question as long as written proof of such can be produced upon request.

P

PARCEL – Any legally described piece of land that may or may not be subdivided. Also known as a tract of land. This also includes any area of land created by an exempt division of land as provided by this Ordinance.

PARK, PRIVATE – A facility or location, owned by one or more individuals and/or businesses designed to service the owner’s recreational needs, used at the discretion of the owner and may or may not be open to the general public.

PARK, PUBLIC – A noncommercial, not-for-profit facility designed to serve the recreation needs of the residents of White County or any of its municipalities. Such facilities include subdivision recreation facilities, community parks, regional parks and special use facilities. Such facilities may also include but shall not be limited to school and religious institution ball fields, playgrounds, tracks or other outside activity areas; if they meet the above definition. Commercial amusement facilities such as water slides, go-cart tracks and miniature golf courses shall not be considered parks.

PARKING, EXCESS - An area of ground committed to accommodating peak capacity parking requirements which occur on a sporadic basis. These areas are only allowed in unincorporated areas of the County and outside the defined boundaries of Idaville and Buffalo. These areas are not required to be paved. They may be grass or gravel covered. Each excess parking space requires the same space and aisle measurements as a right-angle parking space as defined in Table 8.2 of Chapter 8: Parking and Loading Standards, of the White County Indiana Zoning Control Ordinance.

PARKING LOT - An off-street, ground level, unenclosed area of land intended to be used for periodic storage of operable passenger automobiles, commercial vehicles, trailers or other units designed for use on public or private roads. A parking lot may be available to the public as an accommodation to clients or customers, whether for free of charge or for compensation.

PARKING LOT, SPECIAL EVENT – An off-street, ground level, open area to be used temporarily for the storage of passenger vehicles during a special event.

PARKING SPACE - A space designated for the temporary parking of a motor vehicle, trailer or other unit designed for use on public or private roads.

PARKING STRUCTURE: A structure or portion thereof, either privately or publicly owned, composed of one or more levels or floors used exclusively for the parking or storage of Class I and Class II motor vehicles. A parking structure may be totally below grade, as in an underground parking garage, or either partially or totally above grade with those levels being either open or enclosed.

PARTICIPATING LANDOWNER – A person(s) who owns land and has entered into a fully executed contractual agreement associated with a renewable energy project (commercial wind power project or commercial solar energy system project).

PARTICULATE MATTER - Finely divided liquid or solid material, which is discharged and carried along in the air. This shall not include water droplets, commonly called steam.

PASSENGER VEHICLE – Every vehicle, except motorcycles, designed for carrying twelve (12) passengers or less and used for the transportation of persons, including all vehicles within Classes 1 and 2, as categorized by the Motor Vehicle Manufacturers Association of the United States, Inc.

PATIO –A paved, concrete, stone, composite material or concrete block outdoor space or inner courtyard that is used for dining, relaxation or recreation which may or may not be adjacent to a building.

PEDDLER – An individual, company or other entity which sells or solicits door-to-door to residences. Peddlers operate under a transient merchant’s peddler’s permit. For other temporary sales type activities see Street Vendor.

PENNANT – Any lightweight plastic, fabric, or other material, whether or not containing a message of any kind, suspended from a rope, wire, or string, usually in series, designed to move in the wind.

PERFORMANCE GUARANTEE – An amount of money or other negotiable security paid by the applicant or the applicant’s surety to White County, which guarantees that the applicant will perform all actions required by White County regarding an approved plat, and provides that if the applicant defaults and fails to comply with the provisions of any approved plat, the applicant or the applicant’s surety will pay damages up to the limit of the performance guarantee bond, or the surety will itself complete the requirements of the approved plat.

PERFORMANCE STANDARDS – A set of criteria or limits relating to nuisance elements that a particular use or process may not exceed.

PERIMETER RETAINING WALL – A perimeter non-load-bearing structural system completely enclosing the space between the floor joists of a manufactured or mobile home and the ground.

PERMANENT FOUNDATION – A structural system for transposing to the earth at a depth below the established frost line without exceeding the safe bearing capacity of the supporting soil.

PERMITTED STRUCTURE OR USE – Any structure authorized or permitted alone or in conjunction with another structure in a specific district and subject to the limitations of the regulations of such district.

PERMITTED USE - Any use authorized or permitted alone or in conjunction with another use in a specific district and subject to the limitations of the regulations of such use district.

PERSON - A corporation, firm, partnership, association, cooperative organization or any other group acting as a unit, as well as a natural person.

PERSONAL/PROFESSIONAL SERVICES – Any business entity or enterprise whose primary purpose is to offer service(s) to the general public excluding medical or any personal or professional service type listed individually in Appendix A, Official Schedule of Uses.

PET GROOMING, DOMESTIC (PET SPA) - A facility which provides pet grooming services such as, but not limited to, teeth cleaning, hair cutting, shampoos, nail clipping and such similar type activities. These short-term facilities are not allowed to accommodate overnight pet stays or utilize outdoor kennels (a fenced yard is permissible). The operating hours of this facility would be allowed between 6:00 am and 8:00 pm.

PLAN COMMISSION – The White County Area Plan Commission.

PLAN, CONCEPT – Written and graphic documents submitted for subdivision plats, development plans, Planned Unit Developments, annexation, and rezoning petitions that indicate in a conceptual form the proposed land uses and their overall impact on the subject lot and surrounding area.

PLAN, PRELIMINARY - An initial map of a subdivision of land or development plan that is presented to the proper review authority for preliminary approval

PLANNED UNIT DEVELOPMENT (PUD) - A large-scale unified development meeting the requirements for zoning approval under the provisions of Chapter 6, Planned Unit Development of this Ordinance.

PLAT - A Map or Chart indicating the subdivision or re-subdivision of land, intended to be filed for record.

PLAT, FINAL – The final map of all or a portion of a subdivision or development plan that is presented to the proper review authority for final approval.

PLAT, PRELIMINARY -- The preliminary drawing or drawings, described in these regulations, indicating the proposed manner or layout of the subdivision to be submitted to the Commission for approval.

POLE BARN (POST & FRAME BARN) – A building utilizing a frame system of wood roof trusses connected to treated poles that are anchored into the ground, generally with cement and/or rocks. The system includes structural members such as wall headers, roof pulins and wall girts to support the exterior cladding (siding & roofing). Boards and metal are used for the sides and roof and attached with screws and/or nails.

POLICE STATION – A location that serves as headquarters for police which serves as a place from which police officers are dispatched and to which arrested persons are initially brought.

PORCH - A roofed-over structure, other than a stoop, projecting out from the wall or walls of a main structure which may be open or enclosed but which does not provide facilities for heat or air conditioning.

PORTABLE POTTY aka PORT-a-POT, PORTABLE TOILET, PORTA POTTIE AND PORTA LOOS: A portable structure designed for the receipt of human waste containing a chemical toilet used as a temporary toilet for construction sites, festivals and large gatherings. Any other use for which a Portable Potty is intended is required to obtain a temporary use permit and limited to on-site location for no more than thirty (30) days.

POST OFFICE – A building where the primary purpose is receiving, sorting and distributing United States mail and where various postal materials are sold and where postal services are provided.

PREMISES - A lot or plot of land, including any buildings thereon.

PRINCIPAL STRUCTURE – The primary structure on a property.

PRINCIPAL USE - The primary use to which a property is devoted and as the main purpose for which the property exists.

PRINTING, LITHOGRAPHING, PUBLISHING OR PHOTOGRAPHY ESTABLISHMENTS – A commercial printing operation involving a process that is considered printing, imprinting, reproducing, or duplicating images and using printing methods including but not limited to offset printing, lithography, web offset, flexographic, and screen process printing.

PROPERTY LINE – A line, established by survey, including its vertical extension which: (1) separates real property owned or controlled by another person; and (2) separates real property from the public right-of-way.

PROPERTY, NON-PARTICIPATING (See “NON-PARTICIPATING PROPERTY”)

PUBLIC WAY – An alley, avenue, boulevard, bridge, channel, ditch, easement, expressway, freeway, highway, land, parkway, right-of-way, road, sidewalk, street, subway, tunnel, viaduct, walk or other ways in which the general public or a public entity have a right, or which are dedicated, whether improved or not.

R

RABBIT – A burrowing, gregarious, plant eating mammal with long ears, long hind legs and a short tail. The mammal is in the family Leporidae of the order Lagomorpha.

RACE TRACK – A specially surfaced course upon which races are held.

RADIO, TV, MUSIC STUDIO/STATION – A facility utilized for sound recording and mixing or for the transmission of content, either digital or analog, over terrestrial television or for the transmission of signals through free space by electromagnetic waves with frequencies below visible light.

RAILROAD FACILITIES – The occupation and use of land, buildings, and structures for purposes directly connected with rail transportation of articles, goods, and passengers, including such facilities as tracks, sidings, signal devices and structures, shops and yards for maintenance and storage of rail machinery, loading platforms, and passenger and freight terminals, but excluding freight terminals and yards, and similar facilities, which are maintained and operated by the owning railroad or by a lessee for the purposes auxiliary to rail transportation, or by a lessee for the purposes auxiliary to rail transportation; provided, however, that the operation of such facilities as a hobby or as part of an amusement business shall not be considered a railroad facility.

RAILROAD RIGHT-OF-WAY - A strip of land with tracks and auxiliary facilities for track operation, but not including depots, loading platforms, stations, train sheds, warehouses, car shops, car yards, locomotive shops or water towers.

RAISING AND BREEDING OF NON-FARM FOWL OR ANIMALS, COMMERCIAL - The keeping of domesticated animals which are kept for personal or agricultural use, or raised for sale and profit. Does not include commercial kennels or exceptions made under the area of Micro-Farming.

RECREATION, CAMPGROUND – A primitive and/or improved parcel of land used or intended to be used for temporary occupancy by campers, through the use of recreational vehicles, travel trailers, mobile homes, tents, cabins, or other temporary accommodations.

RECREATION FACILITY, COMMERCIAL - Recreation facilities which are operated by a private entity, individual or otherwise.

RECREATION FACILITY, NON-COMMERCIAL - - Recreation facilities which are operated by a non-profit organization.

RECREATIONAL FACILITY, INDOOR - A place primarily designed and equipped for the conduct of sports and leisure-time activities indoors. Such facility may be either public or private and open only to members or to the general public. Activities may include, but are not limited to swimming pool, tennis, racquetball, basketball, bowling, children's play equipment, weight training, ice-skating, pool/billiards, and roller-skating, etc.

RECREATIONAL FACILITY, OUTDOOR - A place primarily designed and equipped for the conduct of sports and leisure-time activities outdoors. Such facility may be either public or private and open only to members or to the general public in exchange for an admission fee. Activities may include, but are not limited to, golf courses, game courts, swimming facilities, etc.

RECREATIONAL VEHICLE -- A vehicle designed to provide temporary living quarters for travel recreation or camping which is either self-propelled or mounted on or toward by another powered vehicle. The term includes but is not limited to travel trailers, collapsible trailers, truck mounted campers, motor homes, tent trailers and converted buses and trucks. An RV is not a dwelling.

RECREATIONAL VEHICLE PARK - Any lot or parcel of land used or intended to be used for the accommodation of two or more motor homes or other recreational vehicles for recreational use or transient dwelling purposes. There is no minimum required stay in a recreational vehicle park. Uses where unoccupied for sale or lease, or are stored, are not included.

RECREATIONAL VEHICLE SALES – The use of any building, land area, or other premises or portion thereof, for the display, sale, or lease of new recreational vehicles and related accessory uses.

RECREATIONAL VEHICLE STORAGE, OUTDOOR – An outdoor area that is used for the storage of recreational vehicles

RECYCLABLE MATERIAL - Any material that can be converted into a raw material for use in a manufacturing process. Recyclable materials include but are not limited to glass, metal and plastic containers and paper products.

RECYCLING FACILITY - A building or area where recyclable material only is collected, sorted, and processed, prior to shipment for remanufacture into new materials at a separate facility.

RECYCLING SATELLITE, PRIVATE - Portable or permanent collection containers or vehicles utilized for the collection of recyclable materials from the general public and located at sites separate from a Recycling or Solid Waste Transfer Facility. Collection containers or vehicles are periodically emptied or taken to a location where collected materials are incorporated into a facility's recycling or re-utilization processes. The collection units are operated or managed by a private party, organization or institution and do not include on-site recycling containers or vehicles which are utilized by a property owner, tenant or other interested party for the purposes of on-site waste management efforts. These collection units are part of a community recycling effort sponsored and supported by a legislative body and do not include on-site recycling containers or vehicles which are utilized by a property owner, tenant or other interested party for the purposes of their own waste management efforts.

RECYCLING SATELLITE, PUBLIC - Portable or permanent collection containers or vehicles utilized for the collection of recyclable materials from the general public and located at sites separate from a Recycling or Solid Waste Transfer Facility. Collection containers or vehicles are periodically emptied or taken to a Recycling or Solid Waste Transfer Facility where collected materials are incorporated into a facility's recycling processes. These collection units are part of a community recycling effort sponsored and supported by a legislative body and do not include on-site recycling containers or vehicles which are utilized by a property owner, tenant or other interested party for the purposes of on-site waste management efforts.

REFINERY, PETROLEUM - Oil-related industrial activities involving the processing or manufacture of substances such as: asphalt and tar paving mixtures; asphalt and other saturated felts (including shingles); fuels; lubricating oils and greases; paving blocks made of asphalt, creosoted wood, and other compositions of asphalt and tar with other materials; and roofing cements and coatings.

RELIGIOUS INSTITUTION - A building wherein persons regularly assemble for religious worship and which is maintained and controlled by a non-profit religious body organized to sustain public worship, together with all accessory buildings and uses customarily associated with such primary purpose. This includes synagogue, temple, mosque, church or other such place for worship and religious activities. Also included would be accessory facilities utilized to support activities sponsored by the on-site organization.

RENDERING PLANT -- A processing operation where dead animals, supermarket rejects and/or slaughterhouse waste/remains are recycled into products from human food to biodiesel.

RENTAL, SHORT TERM: A rental period of less than 30 days; typically associated with rentals for visitors, transient travelers, tourists, etc..

RESORT - A hotel or motel containing a total of more than three (3) dwelling units and/or guest rooms and which provides outdoor recreational activities that may include golf, horseback riding, swimming pool, shuffleboard, tennis or similar activities. A resort may furnish services customarily furnished by a hotel, including a restaurant, cocktail lounge, and convention facilities. A resort offers short-term rentals which last less than 30 days. Use as an apartment or other type dwelling unit is prohibited.

RESTAURANT - An establishment with or without table service whose principal business is the selling of unpackaged food and beverages to the customer in a ready-to-consume state, in individual servings or in non-disposable containers regardless of whether consumption is on or off the premises.

RESTAURANT, DRIVE THROUGH – A restaurant with a window designed to accommodate automobile traffic.

RESTRICTIVE COVENANTS - Limitations of various kinds of the usage of lots within a subdivision which are proposed by the subdivider, and, in the case of public health, safety and welfare, by the Commission, that are recorded with the plat and run with the land.

RETAIL ESTABLISHMENT: A commercial enterprise that provides goods and/or services in small quantities directly to the consumer, where such goods are available for immediate purchase and removal from the premises by the purchaser.

RETAIL SHOPPING CENTER - A group of commercial establishments planned, constructed, and managed as a total entity with customer and employee parking provided on-site, provision for goods delivery separated from customer access, aesthetic considerations, and protection from the elements.

RETAIL, TEMPORARY – Retail sales conducted out of a location, structure or business not related to the current use of the site and in operation for no longer than 30 consecutive days at a time.

RETAINING WALL – That portion of a wall or structure that holds back soil or rock to prevent down slope movement or erosion and provide support for vertical or near-vertical grade changes.

RETENTION AREA - An area that is designed to capture and hold specific quantities of storm water indefinitely.

RETREAT – A remote location, with or without religious affiliation, where individuals or groups go to withdraw from normal day to day activities for the purposes of achieving greater inner strength, physical improvement or both. Activities such as prayer, meditation, contemplation or intellectual study or activities to rekindle or deepen one's relationship with God may be utilized. This may take place in either an individual or group setting. Various types of exercise, recreational or worship formats may be offered which may be independent of, or in conjunction with, activities designed to reach mental balance and/or enlightenment.

RIGHT-OF-WAY - A public right-of-way that is dedicated or deeded to the public for public use and under the control of a public agency and is a public or private strip of land acquired that allows for the passage of people or goods. Right-of-way includes passage ways such as freeways, streets, bike paths, alleys, walk ways, trails, water lines, sanitary sewers, and/or other public utilities or facilities. Typically, right-of-way is acquired by reservation, dedication, prescription, or condemnation.

RIGHTS-OF-WAY, APPARENT – A prescriptive easement where the boundaries of the easement are established by the public use of travel, excluding the berm, ditch or shoulder. The easement limits are normally identified by the edge of the paved or graveled portion of the easement necessary to accomplish such use.

RIGHTS-OF-WAY, PUBLIC (ROW) - A strip of land that is dedicated or deeded to the public or a governmental entity which provides for the passage of people or goods. Rights-of ways fall within a defined or legally recognized boundary line. Rights-of-ways are generally found in conjunction with freeways, streets, bike paths, alleys, walk ways, trails, bridges, water lines, sanitary sewers and/or other public utility facilities when rights are conveyed by instrument, prescription or condemnation. Rights-of-way do not include land which is subject to a "license to enter" for a public or private utility or government entity.

RINGELMANN NUMBER - The number of the area on the Ringelmann Chart that most nearly matches the light-obscuring capacity of smoke. The Ringelmann Chart is published by the U. S. Bureau of Mines, and it illustrates graduated shades of gray for use in estimating smoke density. Smoke below the density of Ringelmann No. 1 shall be considered no smoke, or Ringelmann "0".

ROAD BUFFER ZONE - That area of land which lies within twenty (20) feet of any apparent rights-of-way and which is not itself a public right-of-way.

ROOF - The cover of any building, including the eaves and similar projections.

ROOFLINE - The outline or contour of the roof of a building; or the profile of a roof.

ROOSTER – An adult male domestic chicken.

ROTOR DIAMETER – The diameter of the circle described by the moving rotor blades

RUMMAGE SALE – See Garage Sale

S

SALE or LEASE - Any immediate or future transfer of ownership, or any possessory interest in land, including contract of sale, lease, devise, intestate succession, or transfer of an interest in a subdivision or part thereof, whether by metes and bounds, deed, contract, plat, map, lease, devise, intestate, succession, or other written instrument.

SAME OWNERSHIP - Ownership by the same person, corporation, firm, entity, partnership, or unincorporated association, or ownership by different corporations, firms, partnership, entities, or unincorporated associations, in which a stockholder, partner, or associate, or a member of his family owns an interest in each corporation, firm, partnership, entity, or unincorporated association.

SAWMILL – A facility where logs or partially processed cants are sawn, split, shaved, stripped, chipped, or otherwise processed to produce wood products, not including the processing of timber for use on the same lot by the owner or resident of that lot.

SCHOOL, HOME - As regulated by IC 20 and seq., the State of Indiana allows for children to be home educated. The law requires that children be in school from 7-17 years of age and that they attend school for 180 days each year

SCHOOL, TRADE OR BUSINESS - A school conducted as a commercial enterprise for teaching business or secretarial skills, instrumental music, dancing, barbering or hair dressing, drafting, and the like; or for teaching industrial or technical arts.

SCRAP METAL YARD - A general industrial use established independent or ancillary to and connected with another general industrial use, which is concerned exclusively in new and salvaged metal pipes, wire, beams, angles, rods, machinery, parts, filings, clippings, and all other metal items of every type, and which acquires the items incidental to its connection with the other general industrial use or by purchase, consignment or bailment, and which stores, grades, processes, melts, cuts, dismantles, compresses, cleans, or in any way prepares the items for reuse by the connected other general industrial use or for sale and shipment and use in other industries or businesses, including open hearth, electric furnaces and foundry operations. Shall not include junkyards, dumps, or automobile graveyards.

SETBACK – A line indicating the minimum horizontal distance between the right-of-way of any street or property line (whichever is closer) and the foundation (or eave if over 16”). If no foundation is involved, the setback would be measured to the edge of the structure nearest the associated property line or right-of-way.

SEWAGE TREATMENT PLANT, PRIVATE – A facility that will handle all effluent from a building or buildings on-site constructed on-site which is maintained by the private homeowner or an association.

SEWER, PRIVATE - A disposal system, which is not constructed, installed, maintained, operated or owned by a municipality, taxing district established for that purpose or a utility under the jurisdiction of the Indiana Utility Regulatory Commission.

SEWER, PUBLIC - A sewage disposal system which is constructed, installed, maintained, operated and owned by a municipality or taxing district established for that purpose.

SHOOTING RANGE, INDOOR – The use of a structure for archery and/or the discharging of firearms for the purposes of target practice or temporary competitions.

SHOOTING RANGE, OUTDOOR - The use of land for archery and/or the discharging of firearms for the purposes of target practice, skeet and trap shooting, mock war games, or temporary competitions, such as turkey shoots. Excluded from this use type shall be general hunting and unstructured and nonrecurring discharging of firearms on private property with the property owner's permission.

SIDEWALK - A paved surfaced or leveled area, usually parallel to and separate from the street, used as a pedestrian walkway.

SIGN - Any communication device, structure or fixture (including but not limited to letters, words, numerals, figures, emblems, pictures or any part or combination thereof), used for visual communication intended to attract the attention of the public and visible to the public right-of-way or other property. The term "sign" shall not include any flag, badge or insignia of any governmental unit, any item of merchandise displayed within a show window of a business or any graphic display mounted or placed within a building or on the inside of a window even if visible to the public when outside of the building. A sign may have multiple elements if, in the sole opinion of the Executive Director, those elements are related and critical to a sign's single message.

SIGN, ABANDONED – A sign that no longer correctly identifies or advertises a bona fide business, lease or, owner, product or activity.

SIGN, A-FRAME: A sign which bears the resemblance of an "A" in shape and is generally designed to sit unsecured on the ground or placement surface.

SIGN, AGRICULTURAL – A sign related to the sale or use of products related to farming activity and placed on the grounds of farm property.

SIGN, ANIMATED – Any sign that uses movement or change of lighting to depict action or create a special effect or scene.

SIGN AREA - The two-dimensional space utilizing the smallest circle, triangle or rectangle which encloses all elements, excluding the structure unless said structure is a part of the sign proper or display. (See Subsection 10.6.1 for further clarification).

SIGN, AWNING – A sign located on the surface of a structure extending from a building where the structure is utilized to help protect persons or building from outdoor weather conditions.

SIGN, BACK TO BACK (DOUBLE FACED) – See Subsection 10.6.2 Back-to-back signs.

SIGN, BANNER - A temporary sign composed of lightweight, flexible material either enclosed or not enclosed in a rigid frame.

SIGN, BANNER SEASONAL – A banner that displays seasonal themes.

SIGN, BENCH – A sign printed on or mounted to a bench.

SIGN, BILLBOARD – An outdoor advertising sign with a sign area of no less than three hundred (300) square feet and no more than four hundred-fifty (450) square feet.

SIGN BILLBOARD, DIGITAL - Billboards which are electronic image displays, generally computer controlled, using LED or other lighting technology, to present images which may be stationary, moving or a combination thereof. Images and/or ads may rotate or change frequently in slide show fashion. They generally display multiple advertisements or a rotating basis or in slide show fashion. Larger outdoor billboards usually appear alongside roadways, while smaller billboards appear in entertainment venues, such as sports arenas.

SIGN BILLBOARD, TRADITIONAL - Billboards which have a printed face which can be developed on a variety of substrates or in various manners and which have a static message for an agreed upon amount of time, normally measured in day or weeks. Other than exterior illumination features, traditional billboards have no electronic components.

SIGN, CANOPY – A sign located on the surface of a structure extending from a building where the structure is utilized to help protect persons or building from outdoor weather conditions.

SIGN, CHANGEABLE COPY – A sign or portion thereof with characters, letters, or illustrations that can be changed or rearranged without altering the face of the sign.

SIGN COPY (Permanent or Temporary) – The wording or any graphic illustrations on a sign surface either in permanent or removable letter form.

SIGN, DISPOSABLE – A sign intended to be displayed just above the ground which is not permanently affixed and does not use a durable framing material such as metal or wood in its construction.

SIGN, ELECTRONIC MESSAGING; ELECTRONIC MESSAGING CENTER – A sign that is capable of displaying words, symbols, figures or images in an electronic format that can be changed by manual, remote or automatic means.

SIGN FACE - The surface of the sign upon, against or through which the message of the sign is exhibited.

SIGN, GATEWAY - Any permanent, freestanding sign marking the location at which a public street enters a city, town, subdivision, office park or similar unified development which provides only the name of that development. Gateway signs are subject to the same standards, regulations and restrictions as a “Ground” sign.

SIGN, GROUND - A sign supported by one or more uprights or bases in the ground with a sign height of six (6) feet or less.

SIGN, HEIGHT – The distance measured from the average surface grade surrounding the base of a sign to the top of the highest element of the sign. See figure 10.1

SIGN, HISTORICAL - A sign issued by a Federal, State or Local governmental agency/department or to which such agency provides specific design and/or construction standards and which are intended to designate an historic location, site or landmark. Such signs may not be placed in any public right-of-way unless authorized by the appropriate local, legislative body and/or the controlling State or Federal agency/department issuing the sign and/or standard. Nor may the sign be placed in any manner which, in the sole opinion of the Executive Director, would create a nuisance or unsafe condition.

SIGN, HOME OCCUPATION – A sign pertaining to an occupation which is conducted out of a dwelling or one of its accessory structures.

SIGN, ILLEGAL - Signs that do not comply with the Zoning Ordinance.

SIGN, INCIDENTAL - A sign, generally informational with no advertising or promotional message, that has a purpose secondary to the use of the lot on which it is located, such as “no parking”, “Employee of the Month”, “Reserved”, “Entrance”, “Loading Only”, “Keep off the Grass”, and other similar directives.

SIGN, LED – A sign utilizing LED or similar technology to convey its message or advertisement.

SIGN, MARQUEE - A sign located on the surface of a structure extending from a building where the structure is utilized to help protect persons or building from outdoor weather conditions.

SIGN, MONUMENT A monument sign is a permanent, exterior freestanding sign that is not affixed to a building. This kind of sign either sits directly on the ground, on a concrete foundation or is on a low base that makes the sign highly visible and easy to read from the street level. These type signs are classified as “Ground Signs”.

SIGN, MULTI-FACED - Any sign with two (2) or more display or advertising surfaces.

SIGN, MULTIPLE ENTITIES – An on-premise sign or family of signs which includes advertising, messages and/ or identities of more than one business, organization, governmental entity or combination thereof, mounted to a single structure and promotes or identifies entities located on the same parcel/lot as the sign. This category does not include Shared Advertising Signs.

SIGN, NATURAL COMPOSITE - Any sign whose base material is stone, rock, marble, wood or any other natural mineral and is independent of any building or structure.

SIGN, NON-CONFORMING – A sign lawfully erected and maintained prior to the adopting of this ordinance that does not conform with the requirements of this ordinance.

SIGN, NON-PERMANENT – A sign which can be moved or removed without impacting its structure.

SIGN, OFF-PREMISE - A sign that directs attention to a business, commodity, service, organization, activity or entertainment conducted, sold or offered elsewhere than upon the premises where such sign is located or to which it is affixed. This includes billboards.

SIGN, ON-PREMISE - A sign which occupies the same parcel of ground as the business, institution, facility, service or activity of the site.

SIGN, OUTDOOR ADVERTISING – See Billboard.

SIGN, PENNANT – See Banner.

SIGN, PERMANENT – A sign which utilizes footings, a foundation and/or securely attached mounting fixtures as part of its structure.

SIGN, PERMANENT, IDENTIFICATION – A sign in a residential district that provides information regarding ownership, location, use and/or name of a complex used for dwelling purposes; a sign which provides, but is not limited to, information on ownership, location, use and/or name of an institution.

SIGN, POLE - A free-standing sign, usually double-faced, mounted on one or more round poles, square tubes or other fabricated members without any type of secondary support with a sign height greater than six (6) feet.

SIGN, PROJECTION - Any sign supported by a building or other structure and extending outward more than twelve (12) inches or where the face of the sign is perpendicular to surface of the building or structure to which it is mounted.

SIGN, PUBLIC - - A sign authorized by a governmental body or agency or department thereof, limited to providing public safety notices or general information pertinent to the health, safety and welfare of the general public. For purposes of this Ordinance, these signs are treated as public notices and exempt from zoning ordinance regulations and standards.

SIGN, REAL ESTATE – A sign promoting the sale and/or lease of a parcel and/or structure

SIGN, RECONSTRUCTION – Replacement of any sign structure component, excluding mounting or assembly hardware.

SIGN, ROOF - A sign located on or above a roof and which is either directly or indirectly attached to the roof via some type of hardware, framework, brackets or similar device(s) or method(s). Supplemental support or attachment mechanisms and methods secured to a wall or some other structure other than the roof is sometimes required for safety and security reasons.

SIGN, SEARCHLIGHT – A sign projecting a powerful beam of light, either rotating or not, into the atmosphere.

SIGN, SHARED ADVERTISING – Pole signs that are adjacent to an Interstate highway and advertise multiple businesses located near an exit.

SIGN STRUCTURE - The supports, uprights, bracing and frame work for the sign, other than integrated framework on a prefabricated sign. In the case of a sign structure consisting of two or more sides, where the angle formed between any of the sides (or the projection thereof) exceeds fifteen (15) degrees, each side shall be considered a separate sign structure.

SIGN, SUSPENDED – A sign that is suspended from the underside of a horizontal plane surface and is supported by such surface.

SIGN, TEMPORARY – A sign not intended to be permanently affixed.

SIGN, T-FRAME: A sign which bears the resemblance of a “T” in shape and is generally designed to sit unsecured on the ground or placement surface.

SIGN, TOWER – A sign placed on any communication, radio, cell tower or on a wind turbine.

SIGN, VEHICLE - Any motor vehicle or trailer, not regularly used for commercial purposes or is not part of a company’s product inventory which has painted or mounted on it, any sign and which is located in any parking lot, driveway or yard for more than five (5) consecutive business days.

SIGN, WALL – Any sign attached parallel to a wall or painted on the wall surface and supported by such wall or building. Wall signs shall not project more than twelve (12) inches from the building.

SIGN, WINDOW – A sign which utilizes the glass of a window as the surface for placing or constructing of a sign or advertising information and placed entirely within the frame of a window. Any window sign utilizing internal or external illumination must comply with the illumination standards provided in Section 10.4.

SIGN, YARD – A sign designed to be displayed just above the ground which is not permanently affixed, but which uses durable material such as metal or wood for framing.

SITE DEVELOPMENT PLAN – Also referred to as development plan or site plan. A detailed plan, prepared in accordance with the rules and regulations of the appropriate jurisdiction, and submitted to the Plan Commission or other designated body or authority for review and approval. The plan shall illustrate the proposed development or alterations of a site.

SLAUGHTER HOUSE – An independent, commercial facility where animals are killed or where animal carcasses are imported and, in each case, used to be processed for consumption as food products or other commercial purposes. Slaughter House does not include a grocery store, supermarket or other retail food products store which provides butchering as a supplemental service secondary to their other store offerings. A Slaughter House located on a site also

used for a Confined Feeding operation, Digester Operation or other Agricultural Use is considered an accessory use to those activities and exempt from the requirements of Chapter 3, Section 3.19 of the White County Indiana Zoning Control Ordinance.

SLOPE - The face of an embankment or cut section. Any ground whose surface makes an angle with the plane of the horizon. Slopes are usually expressed in a percentage based upon vertical difference in feet per 100 feet of horizontal distance.

SMELTING PLANT – A facility which uses heat, a chemical reducing agent or some other technological method to extract a base metal from a hosting ore. These facilities are classified as “Heavy Manufacturing” plants.

SOCIAL SERVICES - A wide variety of professional activities or methods concerned with providing assistance in various forms to disadvantaged, distressed or vulnerable persons or groups. Social services may serve the needs of children and families, the poor or homeless, immigrants, veterans, the mentally ill, the handicapped, victims of rape or domestic violence or persons dependent on alcohol or drugs. Many such services are often referred to as welfare. For ordinance purposes, refer to the category of Personal/Professional Services.

SOLAR ARAY (aka PHOTOVOLTAIC ARRAY) - Two or more solar panels linked or connected together for the purpose of generating electricity.

SOLAR ARRAY, STEM STYLE - A solar array construction where each solar panel is attached to a support frame, bracket, stand or other apparatus or which utilizes a ballasted footer for panel stabilization. Tree style solar arrays are excluded from this category.

SOLAR ARRAY, TREE STYLE (aka SOLAR TREE) - A solar array construction utilizing a common, vertical “trunk” frame to which extending panel support framework is constructed. This design often mimics the trunk and limb visual image of a natural tree. Tree style solar array units extend vertically a minimum of six feet (6’) from ground or trunk support foundation level. Framework and panel attaching mechanisms may be designed to rotate to maximize a panel or array’s conversion efficiency.

SOLAR CELL (aka PHOTOVOLTAIC or PHOTOELECTRIC CELL) - An electrical device that converts sunlight, or other form of visible light, directly into electricity and is a building block of Solar Panels or used on their own as a power supply for calculators, lights, clocks or individual devices.

SOLAR ENERGY PROJECT – Any development of energy generation involving devices or components which utilize the sun’s rays and/or heat as fuel source.

SOLAR ENERGY PROJECT DEVELOPER – The primary person or entity responsible for development of a solar energy project.

SOLAR ENERGY PROJECT OPERATOR – The primary person or entity responsible for a solar energy systems on-going operations.

SOLAR ENERGY PROJECT OWNER – The person(s) or entity/entities who owns or will own one (1) or more solar energy systems proposed to be located in a site development.

SOLAR ENERGY SYSTEM (SES) - Solar cells, panels and/or arrays, converters and solar infrastructure used to generate thermal heat or electricity.

SOLAR ENERGY SYSTEM, COMMERCIAL (CSE or CSE System) - A system that captures and converts solar energy into electricity that is generated primarily for (1) the purpose of selling electricity at wholesale and (2) for use in locations other than where it is generated and which has a nameplate capacity of at least ten (10) megawatts. The term includes collection and feeder lines, substations, ancillary buildings, solar monitoring stations and accessory equipment or structures. Accessory equipment or structures shall include, but is not limited to, a configuration of solar arrays, converters, transformers, switch cabinets and energy storage devices/housings.

SOLAR ENERGY SYSTEM, COMMERCIAL, PROJECT AREA (Solar Project Boundary) – The area defined by the perimeter property lines, (those property lines not shared with another participating property owner) of all parcels/lots of land identified as participating property owners in a common solar energy project, including any abutting rights-of ways captured within two or more participating properties.

SOLAR ENERGY SYSTEM, COMMUNITY - A Solar Energy System for use with single, two-family or multi-family private dwellings or with business, industrial or commercial applications where the electricity or thermal energy is consumed by individuals or businesses which may or may not be on the parcel upon which the system is located. Energy is not sold for wholesale purposes. This solar system is an accessory use designed to supply electricity or

thermal energy to a community of properties. Solar energy components may be roof top mounted, ground mounted or building integrated.

SOLAR ENERGY SYSTEM COMPOUND/SOLAR ENERGY SYSTEM “OUTER EDGE” – The smallest square, circle, triangle or rectangle which captures the area of land upon which is placed the solar panels, solar arrays, inverters, solar panel/array support and connecting brackets, structures and wiring, transformers, switch cabinets, electricity storage devices, housing as well as any other equipment or facilities associated with a solar energy project. Land used for the infrastructure required to connect to a utility service is not included.

SOLAR ENERGY SYSTEM, CONCENTRATED (CSP) - A Solar Energy System which incorporates mirrors and/or lenses to concentrate sunlight as a component of their operation.

SOLAR ENERGY SYSTEM, INDIVIDUAL (ISE) - A Solar Energy System for use with single, two-family or multi-family private dwellings or with business, industrial or commercial applications where the electricity or thermal energy is consumed on-site and not sold for commercial purposes. This solar energy system is an accessory use designed only to supply electricity or thermal energy to the principal and accessory uses of the site. Solar energy components may be roof top mounted, ground mounted or building integrated.

SOLAR ENERGY SYSTEM, SHARED (SSE) - A Solar Energy System for use with single, two-family or multi-family private dwellings or with business, industrial or commercial applications where the electricity or thermal energy is consumed by individuals or businesses which may or may not be on the parcel upon which the system is located. Energy is not sold for wholesale purposes. This solar system is an accessory use designed to supply electricity or thermal energy to a community of properties. Solar energy components may be roof top mounted, ground mounted or building integrated.

SOLAR FARM (SF): (aka PHOTOVOLTAIC POWER STATION, SOLAR PARK, SOLAR RANCH, SOLAR STATION or UTILITY-SCALE SOLAR STATION, CONCENTRATED SOLAR FACILITY) - A commercial facility constructed with a configuration of Solar Arrays for which the principal purpose is to generate electricity to be sold on a wholesale basis for ultimate placement on the Nation’s electrical grid. This is the principal use for the parcel on which it is located.

SOLAR FARM, PHOTOVOLTAIC POWER STATION, SOLAR PARK, SOLAR RANCH, SOLAR STATION or UTILITY-SCALE SOLAR STATION, CONCENTRATED SOLAR FACILITY – See Commercial Solar Energy System (CSE):

SOLAR FARM COMPOUND - The area of land upon which is placed the solar panels, solar arrays, inverters, solar panel/array support and connecting brackets, structures and wiring as well as any other equipment associated with a Solar Farm installation. Land used for the infrastructure required to connect to the utility service is not included.

SOLAR FARM, CONCENTRATED (CSP) - A Solar Farm which incorporates mirrors and/or lenses to concentrate sunlight as a component of their operation.

SOLAR INSTALLATION, FLOATING - A solar energy system which is constructed on floaters or raft type structures designed to be placed on water surfaces or in areas prone to flooding where the system is designed to deal with the movement and changes in water levels associated with the subject site.

SOLAR INSTALLATION, GROUND MOUNT - A solar energy system which uses stem style solar arrays where no point of the solar array exceeds 10 feet (10’) in height. In stem style solar arrays, panels are mounted essentially parallel to the earth’s surface in a horizontal configuration. In a stem style solar array, the tallest point of the array extends no higher than ten feet (10’) from the ground or base support level. Framework and panel attaching mechanisms may be designed to rotate to maximize a panel or array’s conversion efficiency.

SOLAR INSTALLATION, INTEGRATED - A solar energy system where solar panels and/or arrays are integrated within the design of the exterior components of any building or structure, excludes Roof Top Installations.

SOLAR INSTALLATION, ROOF TOP - A solar energy system where all solar panels or arrays are mounted via some type of framing or bracketry directly to the roof of a primary or accessory buildings or structures. Also included are systems utilizing Solar Shingles.

SOLAR PANEL (aka PHOTOVOLTAIC MODULE) - A bank of interconnected solar cells combined into the form of a panel normally contained by a metal or plastic perimeter frame.

SOLAR SHINGLE (PHOTOVOLTAIC SHINGLE) - Solar panels or solar modules designed to look like and function as conventional roofing materials, such as asphalt or slate, while also producing electricity. These shingles are

constructed with the same durability and flexibility as regular shingles and are designed to withstand rain, wind and hail. Solar shingle installations can also be known as building-integrated photovoltaics.

SPECIAL EVENT – A one-time or infrequently occurring activity held by a private group of persons, firm, organization, association, non-profit entity or business which occurs unrelated to the principal use of the property.

SPORTING EVENT (FOR PROFIT) – An organized activity involving physical exertion and skill that is governed by a set of rules, normally in a competitive environment, operated for the profit of an organization, institution, private party or group of individuals and taking place in a single day or over a period not to exceed seven (7) days. Excluded are sporting events which constitute extra-curricular activities of public or religious institutions.

SPECIAL EXCEPTION USE – A special exception is a use that would not be appropriate generally or without restrictions throughout the zoning division or district but which, if controlled as to number, area, location, or relation to the neighborhood, would promote the public health, safety, welfare, morals, order, comfort, convenience, appearance, prosperity, or general welfare. Such uses may be permitted in such zoning division or district as special exceptions, if specific provisions for such special exceptions are made in this ordinance.

SPECIAL FLOOD HAZARD AREA (SFHA) – Those lands within White County that are subject to inundation by the regulatory flood. The SFHA's of White County are generally identified as such on the Flood Insurance Rate Map of the County as prepared by the Federal Emergency Management Agency and dated September 1, 1988.

STABLE OR BOARDING, COMMERCIAL - Any stable for the housing of horses, mules, donkeys or ponies, operated for remuneration, hire, sale, or stabling; or any stable, not related to the ordinary operation of a farm, with a capacity of more than four (4) horses, mules, donkeys or ponies, whether or not the stable is operated for remuneration, hire, sale or stabling. All stables or boarding outside this definition are considered stables or boarding facilities for private use.

STABLE OR BOARDING, PRIVATE – Any non-commercial stable or boarding operation.

STADIUM, COLISEUM, ATHLETIC FIELD (COMMERCIAL) – A large building with tiers of seats for spectators at sporting or other recreational events.

STAFF – The staff of the Area Plan Commission of White County.

STATE AGENCY - As used in this Ordinance, the term state agency shall mean and include all state agencies, boards, commissions, departments, and institutions, including state educational institutions of the State of Indiana.

STOCKYARD – A large enclosed yard, usually with pens or stables, in which livestock, such as cattle or pigs, are temporarily kept until slaughtered, sold, or shipped elsewhere.

STOOP - A flat area at the front door of a house intended to facilitate entrance to a home; it may or may not be roofed and does not exceed four feet by six feet in size.

STORAGE, BULK - On-site storage of any soil, sand, gravel, clay, mud, debris, vegetation, refuse or any other material, organic or inorganic, in a concentrated state. Storage or parking of motor vehicles but not for the repair or servicing thereof.

STORAGE, COMMERCIAL – A structure whose main use is housing non-agricultural items related to a commercial enterprise. This type of facility is only staffed with employees on an intermittent basis.

STORAGE FACILITY, SELF SERVICE – A building or group of buildings divided into separate compartments used to meet the temporary storage needs of small businesses, apartment dwellers, and other residential uses; and may include refrigerated facilities. A Self Service Storage Facility does not include the keeping of goods, vehicles, materials, equipment or similar such items in any completely unenclosed area.

STORAGE GARAGE – See Garage. A structure or part thereof used for the storage, parking, or servicing/repair of motor vehicles owned by and registered to the property owner or occupant.

STORAGE, OUTSIDE – The keeping of goods, materials, equipment or other property in a location not completely enclosed by walls and a roof.

STORAGE, PERSONAL – A structure whose main use is housing non-commercial items belonging to the property owner or occupant.

STORAGE, PORTABLE – A container, shed, trailer or similar structure, temporarily positioned and not permanently affixed and readily movable upon demand; in which personal items, inventory or equipment are stored.

STORAGE SHED or MINI-BARN - An accessory structure used primarily for storage purposes.

STORAGE TANK, FUEL (COMMERCIAL) – A container or vessel designed and constructed to hold large quantities of fuels (more than five hundred (500) gallons) and is stored pending distribution to points of consumption or redistribution or which is utilized for on-site use.

STORAGE TANK, FUEL (PRIVATE) – A container or vessel limited to holding five hundred (500) US gallons or less of gasoline, kerosene, fuel oil or some other liquid fuel used on-site by the owner or tenant of the property.

STORAGE TANK, GAS (COMMERCIAL) – A container or vessel designed and constructed to hold large quantities (more than five hundred (500) US gallons) of some type of hydrocarbon gas mixture from a source of supply which is then stored pending distribution to points of consumption or for on-site use.

STORAGE TANK, GAS (PRIVATE) – A container or vessel limited to holding five hundred (500) US gallons or less of some type of hydrocarbon gas mixture, normally propane, which is then utilized on-site for personal use such as heating, clothes drying, hot water heating or other personal use.

STORAGE TANK, OIL – A container or vessel designed and constructed to hold oil or other petroleum products pending on-site processing or distribution to processing sites at other locations.

STORAGE TANK, WATER/WATER TOWER – A container or vessel, which may or may not be completely enclosed, which is designed and constructed to hold water, accumulated on-site or from an outside source, which is then stored pending distribution to points of consumption or for on-site usage.

STORAGE YARD - A parcel of ground where the primary use, in whole or part, is for the storage of materials, refuse or equipment (not including junk) which is clean, quiet and free of any objectionable or hazardous element.

STORY - That portion of a building included between the surface of any floor and the surface of the floor next above it. If there is no floor above it, then the space between such floor and the ceiling next above it shall be the Story. For the purpose of this ordinance, a basement shall not be considered a story unless it has been subdivided into rooms and used for tenant purpose.

STORY, HALF - That portion of a building under a sloping, gable, hip, or gambrel roof, the wall plates on at least two opposite exterior walls of which are not more than three (3) feet above the floor level of such half-story.

STREET – A right-of-way that is established for public or private use to provide the principal means of access by the motoring public to abutting property. Types of streets include the following:

ALLEY - A public or private street primarily designed to serve as a secondary access to the side or rear of those properties.

ARTERIAL - Either a boulevard, primary arterial or secondary arterial as defined in this section.

BOULEVARD - A divided arterial street or portion thereof which has a landscaped median strip dividing the lanes carrying traffic in opposite directions.

PRIMARY ARTERIAL - A street intended to move through traffic to and from such major attractors as central business districts, regional shopping center, colleges or universities, military installations, major industrial areas and similar traffic generators within the county, and/or as a route for traffic between communities; a major intra- or inter-city thoroughfare as designated by and shown on the Thoroughfare plan.

SECONDARY ARTERIAL - A street intended to collect and distribute traffic in a manner similar to primary arterials, except that these streets service minor traffic-generating areas such as community-commercial areas, primary and secondary educational facilities, hospitals, recreational areas, churches, and offices, and/or designed to carry traffic from collector streets to the system of primary arterials as designated by and shown on the Thoroughfare Plan.

STREET, DEAD-END - A local street with only one (1) outlet and not having an appropriate terminus (turnaround) for the safe and convenient reversal of traffic including public safety vehicles.

STREET, FRONTAGE - A street intended to move traffic from either a residential neighborhood or a commercial or industrial area to an arterial street, with the purpose of controlling the location and spacing of access points to the arterial street and thereby protecting the integrity of the arterial street as a major mover of traffic. A frontage street usually runs parallel to the related arterial street and may have development only along one (1) side.

STREETS, NONRESIDENTIAL. May be either of the following:

COLLECTOR - A road intended to move traffic from local roads to secondary arterials. A collector road serves a neighborhood or large subdivision.

LOCAL SERVICE - A street intended to provide access to other streets from individual properties in nonresidential areas.

STREET, MAJOR - Any arterial or collector street.

STREET, PERIMETER - Any existing street to which the parcel of land to be subdivided abuts on only one (1) side.

STREET, PLACE - A short residential local service street, cul-de-sac, or court with a maximum development potential of ten (10) residential units.

STREET, PRIVATE - A right-of-way or easement for the public use for vehicular and pedestrian traffic, which is owned and maintained by a private person or entity and not by a governmental body. Use of a private street may be limited by its owner or owners. Private streets may serve residential or nonresidential properties.

STREET, PUBLIC - A right-of-way dedicated for the public use for vehicular and pedestrian traffic to be owned and maintained by the governmental body having jurisdiction. Other ancillary uses such as drainage and/or utility facilities may also be included within public rights-of-way.

STREETS, RESIDENTIAL - Any of the streets defined as follows:

COLLECTOR - A street intended to move traffic from local streets and cul-de-sacs in residential neighborhoods to primary or secondary arterials as designated and shown on the Thoroughfare Plan.

CUL-DE-SAC - A local street with only one (1) outlet and having an appropriate terminus (turnaround) for the safe and convenient reversal of traffic movement, including public safety vehicles, and intended to provide access to other streets from individual properties in residential neighborhoods.

LOCAL SERVICE - A street intended to provide access to other streets from individual properties in residential neighborhoods.

STREET VENDOR - Any person or entity engaged in the sale of food, beverages, merchandise, or services for immediate or timed delivery from a vendor stand, table, vehicle, trailer or other readily movable structure or from his or her person. These activities are not located in a building nor operate under the same registered retail merchant's certificate as any other business on the same lot. For door-to-door sales to residences, see Peddler.

STRUCTURAL ALTERATION - Any change in the supporting members of a building, such as bearing walls or partitions, columns, beams or girders, or any substantial change in the exterior walls or the roof.

STRUCTURE - Anything constructed or erected which requires location on or in the ground or attachment to something having a location on or in the ground. The term also includes a gas or liquid storage tank, a manufactured home, or a prefabricated building. The term also includes recreational vehicles to be installed on a site for more than 180 days.

STRUCTURE, NON CONFORMING (LEGALLY ESTABLISHED) - Any continuous, lawfully established building or structure erected or structurally altered prior to the time of adoption, revision, or amendment of this Ordinance or granted a variance from this Ordinance, but which fails, by reason of such adoption, revision, amendment, or variance, to conform to the present requirements of the zoning district in which it is located.

STRUCTURE, PRIMARY - A structure which is the main or principal structure on the lot on which said structure is situated.

STRUCTURE, TEMPORARY - A structure without any foundation or footings and which is removed when the designated time period, activity or use for which the temporary structure was erected has ceased.

SUBDIVIDER - Any person having an interest in land that is the subject of an application for subdivision. Also, a person submitting an application for a subdivision.

SUBDIVISION - The division of land as defined in The White County Subdivision Control Ordinance.

SUBDIVISION, AMENDED - A change in a recorded subdivision plat if the change affects any street layout or area reserved thereon for public use of any lot line; or if it affects any map or plan legally recorded prior to the adoption of any regulations controlling subdivisions.

SUBDIVISION, MAJOR –The process of laying out a parcel of raw land into lots, blocks, streets, and public areas for residential development.

SUBSTANTIAL DAMAGE - Damage of any origin sustained by a structure whereby the cost of restoring the structure to its before-damaged condition would equal or exceed 50 percent of the market value of the structure before the damage occurred.

SUBSTANTIAL IMPROVEMENT – Any reconstruction, rehabilitation, addition, or other improvement of a structure, the cost of which equals or exceeds fifty (50) percent of the market value of the structure before the start of construction of the improvement. This term includes structures which have incurred “substantial damage” regardless of the actual repair work performed. The term does not include improvements of structures to correct existing violations of state or local health, sanitary, or safety code requirements or any alteration of a “historic structure”, provided that the alteration with not preclude the structures continued designation as a “historic structure.”

“Substantial” Modification (as it pertains to a wireless support structure) – a modification of a wireless support structure by the greater of: 1) ten percent (10%) of the original height of the wireless support structure or 2) twenty (20) feet; or, addition of an appurtenance to the wireless support structure that protrudes horizontally from the wireless support structure more than the greater of: 1) twenty feet or 2) the width of the wireless support structure at the location of the appurtenance or 3) increases the square footage of the equipment compound in which the wireless facility is located by more than two thousand five hundred (2,500) feet. The term does not include increasing the height of a wireless support structure to avoid interfering with an existing antenna or increasing the diameter or area of a wireless support structure to shelter an antenna from inclement weather or connect an antenna to a wireless support structure by cable.

SUBSTATION (WECS) – A structure containing apparatus that connects the below- or above-ground electrical collection lines of the WECS to the electric utility grid, with or without increasing the voltage.

SUPPORT SYSTEM (FOUNDATION) - A combination of footings, piers, caps, plates, and shims, which, when properly installed, support the manufactured or mobile home; footings being the part of the support system which transmit loads to the soil at or below the surface and the frost line; piers and caps being the part of the support system between the footing and the home, exclusive of plates and shims; plates and shims being the cushion of wood or other approved material, which are used to fill the gap between the top of the pier caps and the frame of the home.

SWIMMING POOL, PRIVATE - A swimming pool used only by the owner of the pool and the owner’s invited guests, and which is an accessory use at a private residence or private commercial operation.

T

TABLED – The Plan Commission has determined by motion and vote to carry over an agenda item for discussion at the next regularly scheduled meeting.

TATTOO PARLOR - A commercial business where tattooing is performed for compensation.

TATTOOING – A placement in human tissue of any indelible design, letter, scroll, figure, symbol, or other mark placed with the aid of needles or other instruments; or any design, letter, scroll, figure, or symbol done by scarring upon or under the skin.

TAVERN - An establishment where alcoholic beverages are sold to be drunk on the premises. Includes bars, night clubs, and cocktail lounges.

TAXICAB - A vehicle for hire which includes a provided driver which conveys passengers between locations of their choice which charges a fare, historically determined by a taximeter. A Taxicab is limited to no more than seven (7) passengers.

TAXICAB COMPANY – A private enterprise which offers Taxicab services to the general public.

TECHNICAL REVIEW COMMITTEE - A panel established by the County to provide technical knowledge and services to the Area Plan Commission in the administration of the zoning and subdivision control ordinances.

TEMPORARY STRUCTURE - A structure without any foundation or footing and removed when the designated time period, activity, or use for which the temporary structure was erected has ceased.

TEMPORARY USE – Those land uses and structures that are needed or are in place for only short periods of time.

TENT - A tent is a portable, collapsible shelter which utilizes a fabric covering supported by one or more poles and secured by ropes or rope equivalents fastened to pegs in the ground. A carport or accessory port, even if one utilizes a canvas covering is not a tent.

TERRACE (VERANDA) - A deck which is raised more than six (6) feet above grade.

THEATER, INDOOR - A building or part of a building devoted to showing motion pictures, or for dramatic, dance, musical, or other live performances.

THEATER, OUTDOOR – An outdoor area, building, part of a building, structure, or defined area utilized primarily for the presentation of film, television, music video, multimedia, performing arts or other related activities. Also, includes a drive-in theater.

THERAPEUTIC HORSEBACK RIDING/EQUINE-ASSISTED ACTIVITY/ADAPTIVE RIDING – A facility at which disabled individuals ride horses to relax, to develop muscle tone and coordination as well as build individual confidence and well-being.

THOROUGHFARE PLAN - The part of the Comprehensive Plan, now or hereafter adopted, which includes a major street and highway plan and sets forth the location, alignment, dimensions, identification, and classification of existing and proposed streets, highways, and other thoroughfares.

TICKET BOOTH - A temporary building and located on private property for the purpose of manually or electronically charging pedestrian or vehicular traffic a fee in association with entertainment associated with Indiana Beach without impeding or restricting ingress or egress.

TOWNHOUSE - A single-family dwelling unit constructed in a row of attached units that are separated by property lines with open space on at least two (2) sides.

TRACT - Any area of land that has not been subdivided by this Ordinance or any prior subdivision ordinance or that area of a larger property that remains after a subdivision or exempt division and is typically described by metes and bounds or aliquot part.

TRAFFIC CONTROL DEVICES - All signs, signals, markings and devices placed or erected by authority of the Governing Body, complying with the State Statute Manual of Uniform Traffic Control Devices.

TRANSFER STATION, OTHER – A place or facility where non-hazardous materials or products are taken from a transport vehicle (railway, plane, trailer, automobile, truck, van or any other similar unit used for transporting materials from one location to another) with the intent of transferring that material or product to another transport vehicle for conveyance to another site and where any on-site storage of materials or products does not exceed seven (7) days.

TRANSFER FACILITY, SOLID WASTE -A place or facility where nonhazardous solid waste materials are taken from a collection vehicle, temporarily stored or stockpiled, and ultimately placed in a transportation unit for movement to another facility.

TRAVEL TRAILER - A vehicular, portable structure designed or used as a recreational dwelling, no more than thirty-five (35) feet in length built on a chassis, having a body width not exceeding eight feet and designed to move on the highway, not under its own power.

TRUCK FREIGHT TERMINAL – A building or area in which freight brought by motor truck is assembled and/or stored for routing in intrastate shipment by motor truck.

TRUCK STOP - A site providing specialized facilities for retail fueling services for Class I, II, III and higher commercial and personal vehicles; the site may include related facilities including but not limited to retail sales of groceries and household items, restaurants, showers and overnight parking.

TRUCK WASH - An activity conducted for the purposes of cleaning Class III or higher commercial vehicles, whether performed automatically, semi-automatically or manually.

U

URBAN AREA – Land within a city or town’s corporate boundaries or any area where the residential density is such that there are 8 residences with a quarter-mile-square area extending beyond the city or town’s corporate boundaries or if the land surrounding the corporate boundaries has already been approved for residential development and the minimum density of the proposed development is 8 residences within a quarter-mile-square area.

USE - The purpose for which a lot, building or other structure or tract of land may be designated, arranged, intended, maintained or occupied; or any activity, occupation, business, or operation carried on or intended to be carried on in a building or other structure on a tract of land.

USE, CONFORMING - A use or activity of a structure or land that is permitted or approved as a special exception use in the district where it is situated and which lawfully conforms to the regulations of that district in which it is located and all other regulations of this Ordinance.

USE, EXISTING - The use of a lot or structure at the time of the enactment of this Ordinance.

USE, INCOMPATIBLE – A use or service that is capable of direct association with certain other uses because it is contradictory or incongruous.

USE, NON-CONFORMING - A use or activity of structure or land which lawfully existed prior to the adoption, revision, or amendment of this Ordinance, but which fails by reason of such adoption, revision or amendment to conform to the use district in which it is located.

USE, PERMITTED -- A use which may be lawfully established in a particular district or districts (provided it conforms with all requirements, regulations, and performance standards, if any of such district).

USE, PRINCIPAL - The primary use to which a property is devoted and as the main purpose for which the property exists. A principal use may be authorized as either a permitted use or a special exception use.

USE, SPECIAL EXCEPTION – The authorization of a use that is so designated as being permitted in the district if it meets special conditions, and upon application, is specifically authorized by the Board of Zoning Appeals.

USE, TEMPORARY - A prospective use, intended for limited duration, to be located in a zoning district not permitting such use, and not continuing a nonconforming use or building.

UTILITIES - Infrastructure services, including those basic utilities, and the structures necessary to deliver those services. Those services may be provided by a public or private agency. Examples include water, sanitary sewer, electricity, natural gas, and telephone.

UTILITY FACILITY, PUBLIC A building or structure used or intended to be used by any public utility, including but not limited to any wastewater treatment plant reservoir, tank, or other storage facility; water treatment plant, well, reservoir, tank, or other storage facility; electric generating plant, distribution, or transmission substation; telephone switching or other communications plant, earth station, or other receiving or transmission facility; any storage yard for utility equipment or vehicles; gas line; and any parking lot for parking vehicles or automobiles to serve the utility.

UTILITY FACILITY, PRIVATE - A building or structure used or intended to be used by any private utility, including but not limited to any wastewater treatment plant reservoir, tank, or other storage facility; water treatment plant, well, reservoir, tank, or other storage facility; electric generating plant, distribution, or transmission substation; telephone switching or other communications plant, earth station, or other receiving or transmission facility; any storage yard for utility equipment or vehicles; gas line; and any parking lot for parking vehicles or automobiles to serve the utility.

UTILITY INSTALLATIONS, PUBLIC - The erection, construction, alteration, or maintenance by public utilities, municipal departments, commissions or common carriers of underground, surface or overhead gas, oil, electrical, steam, pipes, conduits, cables, fire alarm boxes, police call boxes, traffic signals, hydrants, towers and other similar equipment and accessories in connection therewith, by public utility or municipal departments, commissions, or common carriers, for the public health or safety or general welfare.

UTILITY POLE - A structure that:

1) is owned or operated by:

- A. A public utility;
- B. A communications service provider;
- C. A municipality;
- D. An electric membership corporation; or
- E. A rural electric cooperative; and,

2) is designed or used to:

- A. Carry lines, cables, or wires for telephony, cable television or electricity; or,
- B. Provide lighting; or,
- C. Provide signage.

The term does not include a wireless support structure or an electrical transmission tower.

UTILITY, PUBLIC (“UTILITY”) – Every corporation, company, partnership, limited liability company, individual, association of individuals, their lessees, trustees, or receivers appointed by court, that may own, operate, manager or control any plant or equipment within the state for the (1) conveyance of telegraph or telephone messages; (2) production, transmission, delivery, or furnishing of heat, light, water, or power; or (3) collection, treatment, purification, and disposal in a sanitary manner of liquid and solid waste, sewage, night soil, and industrial waste. The term does not include any of the foregoing facilities that a municipality may acquire, own or operate.

UTILITY POLE – A structure that:

1) is owned or operated by:

- A. A public utility;
- B. A communications service provider;
- C. A municipality;
- D. An electric membership corporation; or
- E. A rural electric cooperative; and,

2) is designed and used to:

- A. Carry lines, cables, or wires for telephony, cable television or electricity; or,
- B. Provide lighting.

The term does not include a wireless support structure or an electrical transmission tower.

V

VACATION HOME/VACATION RENTAL/HOLIDAY HOME/HOLIDAY APARTMENT/TOURIST HOME – The renting of a single-family home, duplex, apartment, cottage, condominium, villa, townhome or other similar dwelling on a short-term basis (less than 30 days), normally, nightly or weekly, to tourists and/or transients as an alternative to a hotel, motel bed & breakfast or resort. The property is generally fully furnished. The owner/operator does not utilize the facility as their primary residence.

VARIANCE - A modification of the specific requirements of this Ordinance granted by the Board in accordance with the terms of this Ordinance for the purpose of assuring that no property, because of special circumstances applicable to it, shall be deprived of privileges commonly enjoyed by other properties in the same vicinity and District.

VARIANCE, DEVELOPMENT STANDARDS - A specific approval granted by the Board of Zoning Appeals in the manner prescribed by this Ordinance, to deviate from the development standards (such as height, bulk, area) that this Ordinance otherwise prescribes.

VEHICLE – Anything or unit designed for transporting people or goods, over land or roads; vehicles shall include, but are not limited to, Class I and Class II vehicles, trailers, carts and recreational vehicles.

VEHICLE, CLASS I - Any non-commercial vehicle under 26,000 pounds primarily designed and used for private passenger use. These vehicles include passenger cars, light trucks, SUV, etc.

VEHICLE, CLASS II - Any other type of non-commercial vehicle under 26,000 pounds not covered by a Class I Vehicle. These vehicles could include trailers, boats, medium trucks, small box van, etc.

VEHICLE, COMMERCIAL - Any motor vehicle used or designed: (a) for use in pulling, towing, hauling, transporting, or (b) as a temporary or permanent base, platform, or support for equipment, machinery, materials or other goods (including but not limited to stake body trucks, dump trucks, trucks or trailers having dual rear wheels or more than two (2) axles, semi-trailer tractors, semi-trailers and trailers having dual rear wheels or more than one (1) axle or having an overall length of more than twelve (12) feet; (c) passenger vehicles marked by signage, logos or commercial messages. This definition does not apply to motor vehicles which serve as a source of transportation for an individual residing at the premises where the vehicle is stored or parked on a regular basis and is not used in any commercial activity.

VEHICLE, DISABLED – A Class I or II vehicle that is not operable.

VETERINARY CLINIC/ HOSPITAL - A place used for the care, grooming, diagnosis and treatment of sick, ailing, infirm or injured animals, and those who are in need of medical or surgical attention, and may include overnight accommodations on the premises for treatment, observation and recuperation.

VIBRATION - Oscillatory motion transmitted through the ground.

VICINITY MAP - A drawing located on a plat which shows by dimensions or other means, the relationship of the proposed subdivision or use to other nearby developments or landmarks and community facilities and services within County in order to better locate and orient the area in question.

VISION CLEARANCE AREA - A triangular space at the intersection of any two right-of-way lines (street and street, street and alley) or street and driveway, which is free of any kind of obstruction of vision between certain heights above the established grade, determined by a diagonal line connecting two points measured at a certain distance from the intersection along each right-of-way line.

W

WAIVER - A specific approval granted by the Area Plan Commission in the manner prescribed by the Subdivision Control Ordinance, to deviate from the standards that that Ordinance otherwise prescribes.

WALKWAY/BIKEWAY - A dedicated public way for pedestrian or bike use, whether along the side of a road or not.

WAREHOUSE - A building specially designed for receipt, storage, shipping and handling of goods. These facilities are regularly staffed with employees to manage a company's inventory.

WATER AND SEWAGE DISTRIBUTION AND PUMPING FACILITIES – Infrastructure solely intended for the purpose of supplying potable water and fire protection. This includes the water service pipe, the water distribution pipes and the necessary connecting pipes, fittings, control valves, and all appurtenances in or adjacent to the building or premises.

WATER PARK -An amusement park whose attractions include slides, fountains, and other recreational settings involving water.

WATER, PRIVATE - A water supply system, which is not constructed, installed, maintained, operated or owned by a municipality, taxing district established for the purpose or a utility under the jurisdiction of the Indiana Utility Regulatory Commission.

WATER, PUBLIC - A water supply system, which is constructed, installed, maintained, operated and owned by a municipality, taxing district established for that purpose or a utility under the jurisdiction of the Utility Regulatory Commission of Indiana.

WATERCOURSE - A permanent stream, intermittent stream, river, brook, creek, channel or ditch for water, whether natural or man-made.

WECS PROJECT – A collection of multiple WECS (as defined) as specified in the application for an Improvement Location Permit pursuant to Chapter 7.11 of this Ordinance.

WECS TOWER – The support structure to which the nacelle and rotor are attached, free standing or guyed structure that supports a wind turbine generator.

“WECS” WIND ENERGY CONVERSION SYSTEM – All necessary devices that together convert wind energy into electricity and deliver that electricity to a utility’s transmission lines, including but not limited to the rotor, nacelle, generator, WECS Tower, electrical components, WECS foundation, transformer, and electrical cabling from the WECS Tower, Substation, meteorological towers, communications facilities and other required facilities and equipment, as related to the WECS Project.

- A.) **COMMERCIAL WECS** – A Wind Energy Conversion System constructed on the property of another by a company or corporation or other entity, whose general intent is to capture wind energy and place it on the electrical grid for resale to a public utility. Any WECS designed to generate 40KW in total name plate generating capacity regardless of tower height.
- B.) **MICRO WECS** – a very small Wind Energy Conversion System designed to provide electric power to a home or other local site for use by the owner.
- C.) **NON-COMMERCIAL WECS** – A Wind Energy Conversion System that is generally smaller than a Commercial WECS and the primary purpose is to collect wind energy for the purpose of supplying energy to the owners, such as a business, school or factory.

WELDING SHOP – A facility where metals are joined by applying heat, sometimes with pressure and sometimes with an intermediate or filler metal having a high melting point.

WETLAND - Those areas that are inundated or saturated by surface or ground water at a frequency and duration sufficient to support, and that under normal circumstances do support, a prevalence of vegetation typically adapted for life in saturated soil conditions, or as otherwise defined by the U.S. Army Corps of Engineers.

WHOLESALE BUSINESS – An establishment or place of business primarily engaged in selling and/or distributing merchandise to retailers; to industrial, commercial, institutional, or professional business users, or to other wholesalers; or acting as agents or brokers and buying merchandise for, or selling merchandise to, such individuals or companies.

WILDLIFE PRESERVE - An area maintained in a natural state for the preservation of both animal and plant life.

WIND ENERGY CONVERSIONS SYSTEM (WECS) PROJECT – An individual or multiple WECS covered under a single Improvement Location Permit application pursuant to Chapter 7, Section 7.11 of this Ordinance including all other facilities, equipment and infrastructure supporting WECS installations.

WIND ENERGY CONVERSIONS SYSTEM (WECS) PROJECT DEVELOPER – The primary entity responsible for development of a WECS Project’s plans, installation and launch.

WIND ENERGY CONVERSIONS SYSTEM (WECS) PROJECT OPERATOR – The primary entity responsible for a WECS Projects ongoing operations.

WIND ENERGY CONVERSIONS SYSTEM (WECS) PROJECT OWNER – The entity(ies) which have ownership or legal control of any property within a WECS project area.

WIND ENERGY CONVERSION SYSTEM TOWER (WECS TOWER) – The support structure to which the nacelle and rotor are attached, it can be a free standing or guyed structure that supports a wind turbine generator.

WIND ENERGY CONVERSION SYSTEM TURBINE (WECS TURBINE) – A WEC Tower and Wind Power Device used in combination to produce electricity or mechanical energy from moving air.

WIND ENERGY CONVERSION TURBINE HEIGHT – The vertical distance measured from the average grade at the base of the WEC Tower to the peak of the WPD when the WPD Blade is at its highest point.

WIND ENERGY CONVERSION SYSTEM (WECS) – All necessary devices, equipment and facilities that together convert wind energy into electricity and which have the means to transport the generated electricity to a targeted source. These systems may include, but also are not limited to, the rotor, nacelle, generator, WEC Turbine, electrical components, WEC Tower foundation, transformer, electrical cabling from the WEC Turbine, to any utility substation,

meteorological tower, communication's facility or other required facilities and equipment directly related to the process of converting and moving the electricity converted from wind.

- A.) COMMERCIAL WECS – A WECS project constructed on the property of another by a company or corporation or other entity, whose primary purpose is to capture wind energy and place it on the electrical grid for resale to a public utility; also, any WECS designed to generate 40KW in total name plate generating capacity regardless of tower height.
- B.) MICRO WECS – A Wind Energy Conversion System designed to provide electric power to a home or other local site for use by the owner and which utilizes a WECS Turbine with a height of sixty (60) feet or less.
- C.) NON-COMMERCIAL WECS – An on-site Wind Energy Conversion System designed to provide electric power to a commercial, institutional, industrial or governmental facility or complex and which utilizes a WECS Turbine of more than sixty (60) feet but less than two hundred (200) feet in height.

WIND ENERGY (POWER) PROJECT, COMMERCIAL: A system of related wind energy conversion devices constructed by a company, corporation or other entity, whose general intent is to capture wind energy and place it on the electrical grid for resale to a public or government owned utility.

WIND POWER DEVICE (WPD) – A device, including a windmill or a wind turbine, that is designed to use the kinetic energy of moving air to provide mechanical energy or to produce electricity.

WINERY – An agricultural processing facility for the commercial purpose of processing grapes, other fruit products, or vegetables to produce wine or similar spirits. Processing includes wholesale sales, crushing, fermenting, blending, aging, storage, bottling, administrative office functions, for the winery, and warehousing. Retail sales and tasting facilities of wine and related promotional items may be permitted as part of the winery operations.

WIRELESS COMMUNICATIONS SERVICE – Services, whether mobile or at a fixed location, that are provided using wireless facilities through a licensed or unlicensed spectrum.

WIRELESS EQUIPMENT COMPOUND (when applied to a wireless communication site) - The area that surrounds or is near the base of a wireless support structure and encloses a wireless facility.

WIRELESS FACILITY - A set of equipment and network components that are owned & operated by a communication service provider; and, necessary to provide wireless communications service. The term does not include a wireless support structure.

WIRELESS FACILITY, COMMUNICATIONS – A wireless support structure and wireless equipment compound other than small cell or micro facilities.

WIRELESS FACILITY, MICRO – A small cell facility to which both of the following apply:

- 1) The small cell facility is not larger in dimension than:
 - A. Twenty-four (24) inches in length;
 - B. Fifteen (15) inches in width; and,
 - C. Twelve (12) inches in height.
- 2) If the small cell facility has an exterior antenna, the exterior antenna is no longer than eleven (11) inches.

WIRELESS FACILITY, SMALL CELL – A Small Cell Facility is defined as:

- 1) A personal wireless service facility (as defined by the Federal Telecommunications Act of 1996 as in effect on July 1, 2015); or,
- 2) A wireless facility that satisfies the following requirements:
 - A. Each antenna, including exposed elements, has a volume of six (6) cubic feet or less; and,
 - B. The primary equipment enclosure located with the facility has a volume of twenty-eight (28) cubic feet or less.

Note: The volume of the primary equipment enclosure does not include the following equipment that is located outside the primary equipment enclosure:

- 1) Electric meters
- 2) Concealment equipment
- 3) Telecommunications demarcation boxes
- 4) Ground based enclosures
- 5) Back-up power systems
- 6) Grounding equipment
- 7) Power transfer switches
- 8) Cut-off switches

WIRELESS SUPPORT STRUCTURE - A freestanding structure designed to support components of a wireless facility. The term does not include a utility pole or an electrical transmission tower.

WIRELESS SUPPORT STRUCTURE – A free standing structure designed to support or capable of supporting wireless facilities. The term does not include a utility pole or an electrical transmission tower.

WIRELESS SUPPORT STRUCTURE, HEIGHT OF - The vertical distance measured from the average ground level of the area within the base of the tower, to the highest point on a communications support structure, excluding antennas mounted on the tower.

WIRELESS SUPPORT STRUCTURE, MONOPOLE - A communication support structure consisting of a single pole, constructed without guy wires and ground anchors.

WIRELESS SUPPORT STRUCTURE, SUBSTANTIAL MODIFICATION – Modification of a wireless support structure in a manner that:

- 1) Increases the height of the structure by the greater of:
 - A. Ten percent (10%) of the original height of the wireless support structure; or
 - B. Twenty (20) feet;
- 2) Adds an appurtenance to the wireless support structure that protrudes horizontally from the wireless support structure more than the greater of:
 - A. Twenty (20) feet; or,
 - B. The width of the wireless support structure at the location of the appurtenance; or
- 3) Increases the square footage of the equipment compound in which the wireless facility is located by more than two thousand five hundred (2,500) square feet.

Note: The term does not include:

- 1) Increasing the height of a wireless support structure to avoid interfering with an existing antenna
- 2) Increasing the diameter or area of a wireless support structure to:
 - A. Shelter an antenna from inclement weather; or,
 - B. Connect an antenna to the wireless support structure by cable.

Y

YARD - A space on the same lot with a principal building, open, unoccupied and unobstructed by structures, except as otherwise provided in this Ordinance.

YARD, FRONT - A yard extending across the full width of the lot unoccupied other than by steps, walks, terraces, driveways, lamp posts and similar structures, the depth of which is the least distance between the front lot line and the building line.

YARD, REAR - A yard extending across the full width of the lot between the rear of the principal building and the rear lot line and unoccupied other than by accessory buildings which do not occupy any required space, and/or by steps, walks, terraces, driveways, lamp posts and similar structures, the depth of which is the least distance between the rear lot line and the rear of such principal building.

YARD, SIDE A yard between the principal building and the side lot line, extending from the front yard or from the front lot line where no front yard is required, to the rear yard. The width of the required side yard is measured horizontally at 90° with the side lot line, from the nearest part of the principal building, except in cases where irregular or pie shaped lots are located, then the width of the required side yard shall be an average of the width of the area between the side lot line and the principal building measured horizontally at 90° with the side lot line.

YOUTH/JUVENILE DETENTION CENTER – A secure residential facility for young people, often termed juvenile delinquents, awaiting court hearings and/or placement in long-term care facilities and/or programs.

Z

ZONING - A police power measure, enacted by the legislative body of the County and the local governments, in which the County and incorporated towns are divided into districts or zones within which permitted and special uses are established as are regulations governing lot size, building bulk, placement, and other development standards. White County has an Area Plan Commission zoning designation.

ZONING DISTRICT - A section of the territory within the Jurisdiction of the White County Area Plan Commission for which uniform regulations governing the use, height, area, size, and intensity of use of buildings and land, and open spaces about buildings, are herein established in this ordinance.

ZONING INSPECTOR - The Administrator or the duly appointed administrative officer designated to administer this zoning Ordinance.

ZONING MAP, OFFICIAL - The legally adopted map showing the legally established boundaries or the zoning districts within the County as adopted by the County Commissioners.

ZONING PERMIT - A document issued by the Administrator authorizing the use of lots, structures, uses of land and structures, and the characteristics of the use.

ZOO, PETTING – A location which features a collection of farm animals, docile wild animals and gentle exotic animals, or some combination thereof, designed to allow people, primarily children, the opportunity to hold, pet and/or feed animals in a safe environment.

ZOO/ZOOLOGICAL GARDEN/ZOOLOGICAL PARK –A place where animals are kept in some type of confined manner and exhibited to the public. Animal study and breeding may also be active at the site.

DEFINITION APPENDIX A: WIRELESS COMMUNICATION SITE AND ACTIVITY CONSOLIDATED DEFINITIONS (this section is not intended to be all inclusive and has been included for ease of reference only). Any contradictions between this Appendix and the Definition's main body, the Definition's main body rules.

ANTENNA - Any system of wires, poles, rods, reflecting discs, or similar devices used for the transmission or reception of electromagnetic waves external to or attached to the exterior of any building or, for the purpose of wireless communication service, any communications equipment that transmits or receives electromagnetic radio signals used in the provision of wireless communications service.

BASE STATION - A station located at a specific site that is authorized to communicate with mobile stations. The term includes all radio transceivers, antennas, coaxial cables, power supplies, and other electronics associated with a station.

COLLOCATION – The placement or installation of a wireless facility on existing structures that include a wireless facility or a wireless support structure, including water towers and other buildings or structures.

COMMUNICATIONS SERVICE PROVIDER – A person or entity that offers communications service to customers in Indiana, without regard to the technology or medium used by the person or entity to provide the communications service. This term includes a provider of commercial mobile service as defined in 47 U.S.C. 332.

FACILITY, WIRELESS - A set of equipment and network components necessary to provide wireless communications service. The term does not include a wireless support structure.

“SUBSTANTIAL” MODIFICATION (as it pertains to a wireless support structure) – A modification of a wireless support structure by the greater of: 1) ten percent (10%) of the original height of the wireless support structure or 2) twenty (20) feet; or, addition of an appurtenance to the wireless support structure that protrudes horizontally from the wireless support structure more than the greater of: 1) twenty feet or 2) the width of the wireless support structure at the location of the appurtenance or 3) increases the square footage of the equipment compound in which the wireless facility is located by more than two thousand five hundred (2,500) feet. The term does not include increasing the height of a wireless support structure to avoid interfering with an existing antenna or increasing the diameter or area of a wireless support structure to shelter an antenna from inclement weather or connect an antenna to a wireless support structure by cable.

UTILITY, MUNICIPAL – Every utility owned or operated by a municipality

UTILITY, PUBLIC (“UTILITY”) – every corporation, company, partnership, limited liability company, individual, association of individuals, their lessees, trustees, or receivers appointed by court, that may own, operate, manager or control any plant or equipment within the state for the (1) conveyance of telegraph or telephone messages; (2) production, transmission, delivery, or furnishing of heat, light, water, or power; or (3) collection, treatment, purification, and disposal in a sanitary manner of liquid and solid waste, sewage, night soil, and industrial waste. The term does not include any of the foregoing facilities that a municipality may acquire, own or operate.

UTILITY POLE – a structure that:

1) is owned or operated by:

- A. A public utility
- B. A communications service provider;
- C. A municipality;
- D. An electric membership corporation; or
- E. A rural electric cooperative; and,

2) is designed and used to:

- A. Carry lines, cables, or wires for telephony, cable television or electricity; or,
- B. Provide lighting.

The term does not include a wireless support structure or an electrical transmission tower.

WIRELESS EQUIPMENT COMPOUND (when applied to a wireless communication site) - The area that surrounds or is near the base of a wireless support structure and encloses a wireless facility.

WIRELESS FACILITY - A set of equipment and network components necessary to provide wireless communications service. The term does not include a wireless support structure.

WIRELESS SUPPORT STRUCTURE - a freestanding structure designed to support components of a wireless facility. The term does not include a utility pole or an electrical transmission tower.

WIRELESS SUPPORT STRUCTURE, HEIGHT OF - The vertical distance measured from the average ground level of the area within the base of the tower, to the highest point on a communications support structure, excluding antennas mounted on the tower.

WIRELESS SUPPORT STRUCTURE, MONOPOLE - A communication support structure consisting of a single pole, constructed without guy wires and ground anchors.

APPENDIX A: OFFICIAL SCHEDULE OF USES

USE	CFO	L-1	A-1	A-2	RR	R-1	R-2	R-3	R-4	B-1	B-2	B-3	B-4	B-5	I-1	I-2	I-3	AED
Adult Entertainment Business											S							
Agri Bio Production				P												P	P	
Agricultural Industry			S	P													P	
Agricultural Produce Business, Permanent			P	S	P					P	P	P	P					
Agricultural Produce Business, Seasonal	P		P	A	P					P	P	P	P					
Agricultural Produce Sales, Portable			T		T					T	T	T	T		T	T		P
Agricultural Research Firm			S	P											P		P	
Agricultural Roadside Stand	A	A	A	A	A	A	A			A	A	A	A					A
Agriculture	P		P	P	P													
Agriculture Service & Support			P	P											P	P		
Airport			S	S											S	S		
Amphitheater																		P
Amusement Park																		P
Amusement Park Offices										P	P	P	P	P	P			P
Animal Sanctuary				P														P
Animal Shelter			P	P														
Antennae, Amateur Radio	A	A	A	A	A	A	A	A	A	A	A	A	A	A	A	A		A
Antennae, Radio			A	A								A			A	A		A
Antennae, Television	A	A	A	A	A	A	A	A	A	A	A	A	A	A	A	A		A
Apartment		A	A		A		A	A		A			P					
Apartment, Accessory		A	A			A	A	A										
Apartment, Micro-Unit										P			P					

Pb-Permitted on property abutting RR ROW

Legend:

Ai-Accessory Use-Institutions Only

LP – Permitted on any floor level excluding the ground floor

P-Allowed Use
S-Special Exception Use
A-Accessory Use

T-Temporary Use
Ti-Temporary Use-Institutions Only
Blank-Prohibited Use

USE	CFO	L-1	A-1	A-2	RR	R-1	R-2	R-3	R-4	B-1	B-2	B-3	B-4	B-5	I-1	I-2	I-3	AED
Arcade			A							P	P	P	P					P
Asphalt Plant (manufacturing)			S													S		
Assisted Living Facility	P				P	P	P	P										
Auction, Sale	T	T	T	T	T	T	T	T	T	T	T	T	T	T	T	T		T
Auction Arena or Sales Barn (for livestock)			S	P														
Auction Arena or Sales Yard (excluding livestock)			P								P	P			P			
Automated Teller Machine (ATM)			A							P	P	P	P	P	P	P		P
Automobile Convenience Mart										P	P	P	P		P	P		
Automobile Parts/Supply Retail Establishment										P	P	P	P		P			
Automobile Rental/Leasing Establishment											P	P	P		P			
Automobile Sales			T								P	P	P					
Automobile Service, Major											P	P			P			
Automobile Service, Minor			P							P	P	P	P		P			
Bait Sales	P									P	P	P	P					P
Bake Sale	T	T	T	T	T	T	T	T	T	T	T	T	T	T	T	T		T
Bakery or Delicatessen										P	P	P	P	P				P
Ballroom																		P
Bank										P	P	P	P	P				
Banquet Hall			P							P	P	P	P	P				P
Bathhouse	A	A	A	A	A	A	A	A	A									A
Battery, Storage Field, Wind or Solar			P													P		
Battery, Storage Retrofit, Wind or Solar			P													P		
Batting Cages, Commercial											P	P						P

Pb-Permitted on property abutting RR ROW

Legend:

Ai-Accessory Use-Institutions Only

LP - Permitted on any floor level excluding the ground floor

P-Allowed Use

S-Special Exception Use

A-Accessory Use

T-Temporary Use

Ti-Temporary Use-Institutions Only

Blank-Prohibited Use

USE	CFO	L-1	A-1	A-2	RR	R-1	R-2	R-3	R-4	B-1	B-2	B-3	B-4	B-5	I-1	I-2	I-3	AED
Bazaar	T	T	T		T	T	T	T	T	T	T	T	T	T				T
Bed and Breakfast	P	P	S		S	S	P	P										P
Bio-Medicine Facility				P												P	P	
Boarding House/Rooming House			S		S	S	P	P										
Boat Sales and Service											P	P						P
Boat Storage, Commercial		S	P	P							P	P			P	P		P
Body Piercing										P	P	P	P					P
Botanical Garden/Botanic Garden/Botanical Institution			P															P
Bottled Gas Storage and Distribution Yard											S	S			S	S		
Bowling Alley										P	P	P	P					P
Brew Pub										P	P	P	P					
Brewery																P		
Brewery, Craft																P		
Brewery, Micro											P	P	P		P	P		
Building, Agency or Department		P	P		P	P	P	P	P	P	P	P	P	P	P			
Bunkhouse			A	A														
Bus Garage			S							S	P	P	S		P			
Bus Station, Passenger										S	P	P	S		P			
Cabana	P	P	P		P	P	P	P	P									P
Cabin	P	P	P															P
Campground	S	S	S									S			S			P
Car Wash										P	P	P	P	P				
Caretaker Home	A	A	A	A	A		A	A	A									

Pb-Permitted on property abutting RR ROW

Legend:

Ai-Accessory Use-Institutions Only

LP – Permitted on any floor level excluding the ground floor

P-Allowed Use

S-Special Exception Use

A-Accessory Use

T-Temporary Use

Ti-Temporary Use-Institutions Only

Blank-Prohibited Use

USE	CFO	L-1	A-1	A-2	RR	R-1	R-2	R-3	R-4	B-1	B-2	B-3	B-4	B-5	I-1	I-2	I-3	AED
Carnival	T	T	T		T	T	T	T		T	T	T	T					P
Carport	A	A	A	A	A	A	A	A	A				A					A
Casino																		P
Catering Service			P		P					P	P	P	P	P				P
Cemetery			P							-	P		-	P				
Child Care Center		P	P							P	P	P	P	P				
Child Care Home	P	P	P	P		P	P	P	P									
Child Care House	A	A	A	A	A	A	A	A	A									
Children's Play Equipment	A	A	A	A	A	A	A	A	A	A	A	A	A	A				A
Christmas Tree Sales	Ti	Ti	T	T	Ti	Ti	Ti	Ti	Ti	T	T	T	T		T	T		T
Circus	Ti	Ti	T		Ti	Ti	Ti	Ti	Ti	T	T	T	T					P
Club or Lodge, Private			P							P	P	P	P					
Commissary										P	P	P	P					
Community Center			P			P	P	P	P	P	P	P	P	P				
Community Commons	P	P				P	P	P	P	P	P		P					P
Concessionaire (See Street Vendor and Peddler for similar uses)	A	A	A		Ai	Ai	Ai	Ai	Ai	A	A	A	A					P
Concrete or Cement Batching Plant, Permanent															P	P		
Concrete or Cement Batching Plant, Portable	T	T	T	T	T	T	T	T	T	T	T	T	T	T	T	T		T
Conference Center/Meeting Hall		P	P		A	P	P	P		P	P	P	P	P	A	A		P
Conference Facility										P	P	P	P					P
Confined Feeding Operation				P														
Construction Yard	T	T	T	T	T	T	T	T	T	T	T	T	T	T	T	T		T
Construction, Heavy Contractors			S	S							S	S			P	P		

Pb-Permitted on property abutting RR ROW

Legend:

Ai-Accessory Use-Institutions Only

LP - Permitted on any floor level excluding the ground floor

P-Allowed Use
S-Special Exception Use
A-Accessory Use

T-Temporary Use
Ti-Temporary Use-Institutions Only
Blank-Prohibited Use

USE	CFO	L-1	A-1	A-2	RR	R-1	R-2	R-3	R-4	B-1	B-2	B-3	B-4	B-5	I-1	I-2	I-3	AED
Convenience Store, Neighborhood								P		P	P	P	P					
Convenience Store, Regional											P	P			P			
Convention Center/Exhibition Hall											P	P			P			
Correctional/Penal Facility			S												S			
Cottage/Summer Home		P	P			P	P		P									
Crematory											P	P	P		P			
Day Care Center, Adult	P	P	P	P	P	P	P	P		P	P		P	P				
Digester, Aerobic or Anaerobic			A	P											A	P	P	
Distillery																P		
Distillery, Micro or Boutique											P	P	P		P	P		
Distribution Center			A								S	P			P	P	P	
Driving Range			S		S		S				S	S						P
Dwelling, Farm			P	P	P													
Dwelling, Multi-Family								P										
Dwelling, Single-Family	P	P	P	P	P	P	P	P	P				LP					
Dwelling, Student/Fraternity/Sorority								P										
Dwelling, Two-Family	P	P					P	P					LP					
Educational Facility, Other			P			P	P	P		P	P	P	P	P				
Educational Facility, Private			P			P	P	P		P	P	P	P	P				
Educational Facility, Public			P			P	P	P		P	P	P	P	P				
Electric Vehicle Charging Station, Private (EVCS Private)	A	A	A	A	A	A	A	A	A	A	A	A	A	A	A	A	A	A
Electric Vehicle Charging Station, Public (EVCS Public)		S	S							P	P	P	P	P	P	P	P	P
Engine Repair, Large (See Automobile Service, Major)																		

Pb-Permitted on property abutting RR ROW

Legend:

Ai-Accessory Use-Institutions Only

LP – Permitted on any floor level excluding the ground floor

P-Allowed Use

T-Temporary Use

S-Special Exception Use

Ti-Temporary Use-Institutions Only

A-Accessory Use

Blank-Prohibited Use

USE	CFO	L-1	A-1	A-2	RR	R-1	R-2	R-3	R-4	B-1	B-2	B-3	B-4	B-5	I-1	I-2	I-3	AED
Engine Repair, Small		P									P				P			
Entertainment Facility, Commercial										P	P	P	P					P
Equipment Sales and Leasing											P	P			P			
Ethanol or other similar Bio-processing Plant				S												S		
Event, Barn			S															P
Event, Government		T	T	T	T	T	T	T	T	T	T	T	T		T	T		P
Event, Special	T	Ti	T	T	Ti	Ti	Ti	Ti	Ti	T	T	T	T		T	T		T
Event, Sporting	T	Ti	T	T	Ti	Ti	Ti	Ti	Ti	T	T	T	T		T	T		T
Explosives, Use or Storage																S		
Fairgrounds			P															P
Farm Chemical/Fertilizer Supplier			P	P											P			
Farming, Micro		P				P	P	P	P									
Festival	T	T	T		T	T	T	T	T	T	T	T	T	T	T	T		T
Fire, Police, Postal Stations										P	P	P	P		P			
Fireworks Sales										P	P	P	P		P	P		
Flea Market	Ti	Ti	T		Ti	Ti	Ti	Ti	Ti	P	P	P	P		P			P
Funeral Home or Mortuary										P	P	P	P					
Garage, Attached	A	A	A	A	A	A	A	A	A	A			A					A
Garage, Detached	P	P	P	P	P	P	P	P	P									P
Gasoline Service Station										P	P	P	P		P			P
Go-Kart Facility																		P
Golf Course			P		P		P											P
Government Building		P	P		P	P	P	P	P	P	P	P	P	P	P			

Pb-Permitted on property abutting RR ROW

Legend:

Ai-Accessory Use-Institutions Only

LP - Permitted on any floor level excluding the ground floor

P-Allowed Use
S-Special Exception Use
A-Accessory Use

T-Temporary Use
Ti-Temporary Use-Institutions Only
Blank-Prohibited Use

USE	CFO	L-1	A-1	A-2	RR	R-1	R-2	R-3	R-4	B-1	B-2	B-3	B-4	B-5	I-1	I-2	I-3	AED
Grain Elevator			P	P												P		
Grandstand			A		A	A	A	A	A		A	A			A			A
Greenhouse, Commercial			P	P							P	P		P	P			
Greenhouse, Non-Commercial	A	A	A	A	A	A	A	A	A									A
Grocery Store or Supermarket										P	P	P	P					
Group Home								P		P	P		P	P				
Guard Shacks	A	A	A	A	A	A	A	A	A		A	A			A	A		A
Guest House		P																
Gun Sales			P							P	P		P					
Gun Smith			P							P	P		P					
Hatchery, Commercial	S		P	P														
Hazardous Waste Landfill/Facility																S		
Health and Fitness Center								P		P	P	P	P	P				P
Health Center, Public										P	P	P	P	P				A
Heliport			S	S							S	S			S	S	S	
Home Occupation	A	A	A	A	A	A	A	A	A	A			A					A
Hospital										S	P	P			P			
Hotel										P	P	P	P					P
Incinerator			S	P											S	P		
Industrial Waste Facility																S	Pb	
Information Center, Visitor/Tourist	P	P						P		P	P	P	P	P				P
Integrated Center		S									P	P						
Internet Selling Establishment/E-bay Store										P	P	P	P	P				

Pb-Permitted on property abutting RR ROW

Legend:

Ai-Accessory Use-Institutions Only

LP – Permitted on any floor level excluding the ground floor

P-Allowed Use

T-Temporary Use

S-Special Exception Use

Ti-Temporary Use-Institutions Only

A-Accessory Use

Blank-Prohibited Use

USE	CFO	L-1	A-1	A-2	RR	R-1	R-2	R-3	R-4	B-1	B-2	B-3	B-4	B-5	I-1	I-2	I-3	AED
Jail			P								P				P			
Junkyard			S													S		
Kennel, Commercial			P	P														
Kennel, Private			P	P														
Laboratory, Commercial			P								P	P		P	P			
Laboratory, Medical or Dental											P	P		P	P			
Laboratory, Research Activity and Testing											P	P		P	P	P	P	
Land Use Amenity	A	A	A	A	A	A	A	A	A	A	A	A	A	A	A	A	A	A
Landfill																S		
Landfill, Sanitary																S		
Landscape Contractor			P								P	P			P	P		
Laundry Facility, Self Service			A					A	A	P	P	P	P	P				A
Laundry or Dry Cleaning Facility										P	P		P					
Library		P	P		P	P	P	P	P	P	P	P	P	P	P			
Manufactured Home	P	P	P	P	P	P	P	P	P				S					
Manufactured Home Office, Permanent			A	A							S	S		S	P	P		
Manufactured Home Park or Subdivision									P									
Manufactured Home Park or Subdivision, Existing									P									
Manufactured Home Park or Subdivision, Expansion									P									
Manufactured/Mobile Home/RV Dwelling	T	T	T	T	T	T	T	T	T	T			T					
Manufacturing, Extractive – Non-Urban	P	P	P	P	P	P	P	P	P	P	P	P	P	P	P	P	P	P
Manufacturing, Extractive – Urban																S		

Pb-Permitted on property abutting RR ROW

Legend:

Ai-Accessory Use-Institutions Only

LP – Permitted on any floor level excluding the ground floor

P-Allowed Use

T-Temporary Use

S-Special Exception Use

Ti-Temporary Use-Institutions Only

A-Accessory Use

Blank-Prohibited Use

USE	CFO	L-1	A-1	A-2	RR	R-1	R-2	R-3	R-4	B-1	B-2	B-3	B-4	B-5	I-1	I-2	I-3	AED
Manufacturing, Heavy																P	Pb	
Manufacturing, Light															P	P	P	
Marina											P							P
Massage Parlor										P	P	P	P	P				
Mechanical Rides or Attractions	Ti	Ti	T		Ti	Ti	Ti	Ti	Ti	P	P	P	P					P
Medical Clinic							P	P		P	P	P	P	P				
Medical Emergency/Immediate Care Facility										P	P	P	P					
Medical Office										P	P		P	P				
Medical, Mental Health Facility (or Psychiatric Hospital)										S	P	P	S		P			
Meteorological Tower			P	P							S	S			S	S		
Miniature Golf Facility											P	P		P				P
Model Home or Apartment	P	P	P		P	P	P	P	P									
Modular Home	P	P	P	P	P	P	P		P									
Motel											P	P						P
Motorcycle Sales										P	P	P	P		P			
Museum/Gallery		P	P		P	P	P	P	P	P	P	P	P	P	P			
Neighborhood Facility			S			S	S	S		S	S	S	S	S				
Newspaper Publishing										P	P	P	P		P			
Newspaper Stand										P	P	P	P	P	P	P		P
Non-profit/Charitable Organization	A	A	A		A	A	A	A	A	P	P		P	P				
Nursery, Horticultural			P	P							P	P		P	P			
Nursing Home								P		P	P		P	P				
Office Building										P	P	P	P	P			P	

Pb-Permitted on property abutting RR ROW

Legend:

Ai-Accessory Use-Institutions Only

LP – Permitted on any floor level excluding the ground floor

P-Allowed Use
S-Special Exception Use
A-Accessory Use

T-Temporary Use
Ti-Temporary Use-Institutions Only
Blank-Prohibited Use

USE	CFO	L-1	A-1	A-2	RR	R-1	R-2	R-3	R-4	B-1	B-2	B-3	B-4	B-5	I-1	I-2	I-3	AED
Office Research Park											P	P			P		P	
Orchard/Vineyard			P	P	P													
Park, Private	P	P	P		P	P	P	P	P	P	P	P	P	P	P	P		P
Park, Public	P	P	P		P	P	P	P	P		P	P		P				P
Parking Lot	A	A	P	P	A	A	A	P	P	P	P	P	P	P	P	P		P
Parking Lot, Event, Special	T	T	T	T	T	T	T	T	T	T	T	T	T	T	T	T		T
Parking Structure										P	P	P	P		P	P		P
Peddler (See Street Vendor and Concessionaire for similar uses)		T			T	T	T	T	T									
Personal/Professional Services (see definition for exclusions)										P	P	P	P	P				P
Pet Grooming, domestic (Pet Spa)			S								P	P		P	P			
Printing, lithographing, publishing, or photography										P	P	P	P		P			P
Race Track			P															P
Radio, TV, Music Studio/Station	P	A	A		A	A	A	A	A	P	P	P	P	P				
Railroad Facilities			S							S	S	P	S		P	P	Pb	
Raising and Breeding of Non-Farm Fowl or Animals, Commercial			P	P	P													
Recreational Facility, Indoor			A				S	S		P	P	P	P		P			P
Recreational Facility, Outdoor,			A				S	S		P	P	P	P		P			P
Recreational Vehicle Park	S	S	S									P			S			P
Recreational Vehicle Sales											P	P			P			
Recycling Facility																S		
Recycling Satellite, Private			P								P	P			P	P		P
Recycling Satellite, Public			P								P	P			P	P		P
Religious Institution		P	P		P	P	P	P		P	P	P	P	P				

Pb-Permitted on property abutting RR ROW

Legend:

Ai-Accessory Use-Institutions Only

LP – Permitted on any floor level excluding the ground floor

P-Allowed Use

S-Special Exception Use

A-Accessory Use

T-Temporary Use

Ti-Temporary Use-Institutions Only

Blank-Prohibited Use

USE	CFO	L-1	A-1	A-2	RR	R-1	R-2	R-3	R-4	B-1	B-2	B-3	B-4	B-5	I-1	I-2	I-3	AED
Rendering Plant				P												P	P	
Residential Subdivision		P			P	P	P	P	P									
Resort											P							P
Restaurant										P	P	P	P					P
Restaurant, Drive-Through										P	P	P	P					P
Retail Establishment (0 to 99,999 GSF)								S		P	P	P	P					P
Retail Establishment (100,000 GSF or more)											P	P						P
Retail, Shopping Center/Shopping Mall/Strip Mall (See Integrated Center)																		
Retail, Temporary	Ti	Ti	Ti		Ti	Ti	Ti	Ti		T	T	T	T		T	T		T
Retreat			P															
Sales Office/Dwelling Unit	T	T	T		T	T	T	T	T									
Sawmill			T	T													P	
Scrap Metal Yard																	S	
Sewage Treatment Plant, Private		S	S		S	S	S	S	S									
Shooting Range, Indoor											S	S			S	S		
Shooting Range, Outdoor			S	S												S		
Street Vendor (See Concessionaire and Peddler for similar uses)		Ti	Ti		Ti	Ti	Ti	Ti	Ti	T	T	T	T	T	T	T	T	T
Slaughter House			A	A											S	S		
Social Services										P	P		P	P				
Solar Energy System, Commercial (CSE)			P	P											P	P		
Solar Energy System, Individual (ISE)	A	A	A	A	A	A	A	A	A	A	A	A	A	A	A	A	A	A
Solar Energy System, Shared (SSE)	P/A	P/A	P/A	P/A	P/A	P/A	P/A	P/A	P/A	P/A	P/A	P/A	P/A	P/A	P/A	P/A	P/A	P/A
Sporting Event (for profit)	Ti	Ti	T		Ti	Ti	Ti	Ti		T	T	T	T		T	T		T

Pb-Permitted on property abutting RR ROW

Legend:

Ai-Accessory Use-Institutions Only

LP - Permitted on any floor level excluding the ground floor

P-Allowed Use
S-Special Exception Use
A-Accessory Use

T-Temporary Use
Ti-Temporary Use-Institutions Only
Blank-Prohibited Use

USE	CFO	L-1	A-1	A-2	RR	R-1	R-2	R-3	R-4	B-1	B-2	B-3	B-4	B-5	I-1	I-2	I-3	AED
Stable or Boarding, Commercial			P	P	S													
Stable or Boarding, Private			P	P	P													
Stadium, Coliseum, Athletic Field - Commercial											S				P			P
Stockyard			P	P														
Storage Facility, Self Service											P	P			P	P		
Storage Tank, Fuel (Commercial)			A	A							A	A			A	P		A
Storage Tank, Fuel (Private)		A	A	A	A	A	A	A	A		A	A			A	A		A
Storage Tank, Gas (Commercial)			A	A							A	A			A	P		A
Storage Tank, Gas (Private)		A	A	A	A	A	A	A	A									A
Storage Tank, Oil																P		
Storage Tank, Water/Water Tower		P	P	A	P	P	P	P	P	P	P	P	P	P	P	A		A
Storage Yard			A	A								P			P	P		
Storage, Bulk															P	P		
Storage, Commercial										P	P	P	P	P	P	P		P
Storage, Outside/Outdoor											P	P				P		P
Storage, Personal	P	P	P	P	P	P	P	P	P									
Subdivision, Residential Major		P			P	P	P	P	P									
Subdivision, Business/Industrial										P	P	P	P		P	P		
Swimming Pool, Private	A	A	A	A	A	A	A	A	A									P
Tattoo Parlor										S	S	S						S
Tavern										P	P	P	P					P
Taxi Cab Company											P	P						

Pb-Permitted on property abutting RR ROW

Legend:

Ai-Accessory Use-Institutions Only

LP - Permitted on any floor level excluding the ground floor

P-Allowed Use
S-Special Exception Use
A-Accessory Use

T-Temporary Use
Ti-Temporary Use-Institutions Only
Blank-Prohibited Use

USE	CFO	L-1	A-1	A-2	RR	R-1	R-2	R-3	R-4	B-1	B-2	B-3	B-4	B-5	I-1	I-2	I-3	AED
Theater, Indoor											P	P	P					P
Theater, Outdoor	T	T	T		T	T	T	T	T	T	T	P/T	T		S/T	T		P/T
Therapeutic Horseback Riding/Equine-Assisted Activity/Adaptive Riding			P		P													
Ticket Booth																		P
Transfer Facility, Other															P	P	P	
Transfer Facility, Solid Waste																P		
Truck Freight Terminal															S		P	
Truck Stop											S	P			S	P		
Truck Wash			A	A							S	P			S	P		
Utility Facility, Public	P	P	P	P	P	P	P	P	P	P	P	P	P	P	P	P	P	P
Vacation Home/Vacation Rental/Holiday Home/Holiday Apartment/Tourist Home (VRBO)		S	S				S											P
Veterinary Clinic/Hospital			S								P	P		P	P			
Warehouse			A	A											P	P	P	
Water and Sewage Distribution and Pumping Facilities	P	P	P	P	P	P	P	P	P	P	P	P	P	P	P	P	P	P
Water Park	A	A	A		A	A	A	A	A	A	A	A	A	A	A	A		P
WECS – Commercial			P	P							S	S			S	S		
WECS – Micro	P	P	P	P	P	P	P	P	P	P	P	P	P	P	P	P		P
WECS – Non-commercial equal or less than 200 feet in height			P	P	P						S	S			S	S		S
WECS – Non-commercial greater than 200' in height			S	S	S						S	S			S	S		S
Welding Shop			A	A							P	P			P	P		A
Wholesale Business												P			P	P	P	
Winery			P								P	P			P			
Wireless Facility, Communications			P	P	Ai	Ai	Ai	Ai			P	P		P	P	P	P	P

Pb-Permitted on property abutting RR ROW

Legend:

Ai-Accessory Use-Institutions Only

LP – Permitted on any floor level excluding the ground floor

P-Allowed Use
S-Special Exception Use
A-Accessory Use

T-Temporary Use
Ti-Temporary Use-Institutions Only
Blank-Prohibited Use

USE	CFO	L-1	A-1	A-2	RR	R-1	R-2	R-3	R-4	B-1	B-2	B-3	B-4	B-5	I-1	I-2	I-3	AED
Wireless Facility, Micro	A	A	A	A	A	A	A	A	A	A	A	A	A	A	A	A	A	A
Wireless Facility, Small Cell	A	A	A	A	A	A	A	A	A	A	A	A	A	A	A	A	A	A
Youth/Juvenile Detention Center								P							P			
Zoo, Petting (Permanent)											P	P						P
Zoo, Petting (Temporary)			T							T	T	T	T		T	T		P
Zoo/Zoological Garden/Zoological Park																		P

Legend:

P-Allowed Use
 S-Special Exception Use
 A-Accessory Use

Ai-Accessory Use-Institutions Only

T-Temporary Use
 Ti-Temporary Use-Institutions Only
 Blank-Prohibited Use

Pb-Permitted on property
 abutting RR ROW

LP – Permitted on any floor level
 excluding the ground floor

Appendix B: Bulk Use Standards - Residential & Agricultural

Bulk Use Standards		Zoning District								
		CFO	L-1	A-1	A-2	RR	R-1	R-2	R-3	R-4
Minimum Lot Size (SQ FT)	Lot/Parcel Minimum w/sewer	65340	10000	43560	217800	21780	10000	10000	10000	10000 (B)
	Lot/Parcel Minimum w/o sewer	65340	43560	43560	217800	43560	43560	43560	43560	43560
Minimum Living Space (SQ FT)	Compact House/Dwelling Unit (First Floor)	Not Allowed	300	Not Allowed	Not Allowed	Not Allowed	300	300	Not Allowed	Not Allowed
Minimum Building Size (SQ FT)	Standard House/Dwelling Unit	900	900	900	900	900	900	900	900	900
Minimum Living Space (SQ FT)	Standard House/Dwelling Unit (First Floor)	600	600	600	600	600	600	600	600	20
Minimum Lot Width (FT)	Width (At Building Line)	150	60	150	500	150	80	60	60	0
Minimum Front Setback (FT)	Adjacent To A Public or Private Road	30	30	30	30	30	30	30	30	30
	Within A Subdivision	C	C	C	C	C	C	C	C	C
	From Waterside	30	30	30	30	30	30	30	30	30
Minimum Rear Setback (FT)	Principal Structure	20	20	20	20	20	20	20	20	20
	Accessory Structure	4	20	4	4	4	4	4	4	4
Minimum Side Setback (FT)	Principal or Accessory Structure	4	4	4	4	4	4	4	4	4
Maximum Structure Height (FT)	Principal Structure	35	35	35	35	35	35	35	75	35
	Accessory Structure	25	25	B	B	B	25	25	25	25
Maximum Lot Coverage	Principal & Accessory Structures (% of gross lot area)	None	60	None	None	60	60	60	60	60

Foot Notes:

- A For Manufactured Home Parks, As Required By The Area Plan Commission
- B There shall be no height limit provided that for every foot in height the structure is over 19', the side and rear setbacks shall increase one foot
- C In any major or minor, residential, business or industrial subdivision, any valid setbacks or other developmental standards incorporated on the recorded plat or within the covenants and restrictions apply. In all other cases, county setbacks and developmental standards apply

Additional Foot Notes:

- 1 In the case of a legally nonconforming dwelling, the front setback requirement for the parcel shall be established by the distance from the property line or road rights-of-way, whichever is most restrictive, to the foundation of the building
- 2 Within any municipality or any recorded subdivision, each dwelling shall be allowed to add, modify or alter the dwelling utilizing a front setback equivalent to the closest front setback of the dwelling unit on any abutting lot, or one separated only by an alley, which would have a common front property line if extended, however, for any corner lot, the visibility clearance area must be honored
- 3 Any deck built on a property which has the waterside as its front lot line shall be allowed a zero front setback for a deck only
- 4 Any lot determined to be in a lake area which has a property line abutting a road shall require the applicable property line meet a 20' foot minimum setback
- 5 Compact Houses are only permitted on parcels of 5,000 square feet or less
- 6 Any lot or parcel impacted by a transfer of land related to a government taking or purchase or rights-of-way, shall retain conforming status and will have the developments standards applied to that lot or parcel, as configures at the time of the rights-of-way land transfer, adjusted to the level of the taking. Only those specific standards impacted the taking are subject to this adjustment.
- 7 In any residential or agricultural district, the property owner may utilize accessory structure setbacks for a garage, shed, personal storage building or other incidental structure in order that such structure be located in a manner which will preserve the maximum amount of lot area for future lot development.

Appendix B: Bulk Use Standards - Commercial & Industrial

Bulk Use Standard		Zoning District								
		B-1	B-2	B-3	B-4	B-5	I-1	I-2	I-3	AED
Minimum Lot Size (SQ FT)	Lot/Parcel Minimum w/sewer	5000	10000	25000	None	10000	25000	25000	130680	7500
	Lot/Parcel Minimum w/o sewer	130680	130680	130680	None	130680	130680	130680	130680	43560
Minimum Building Size (SQ FT)		None	None	None	None	None	None	None	30,000 (F)	None
Minimum Lot Width (FT)	Width (At Building Line)	50	70	125	0	70	250	250	250	50
Minimum Front Setback (FT)	Adjacent To A Public or Private Road	30	30	30	0	30	30	30	E	20
	Within A Subdivision	D	D	D	D	D	D	D	D	D
	From Waterside	30	30	30	0	30	30	30	E	0
Minimum Rear Setback (FT)	Principal Structure	20	20	20	0	20	20	20	E	20, A & G
	Accessory Structure	20	20	20	0	20	20	20	E	20, A & G
Minimum Side Setback (FT)	Principal or Accessory Structure	B	5	5	0	5	10	10	E	5, A & G
Maximum Structure Height (FT)	Principal Structure	45	45	45	45	45	55	55	55	45
	Accessory Structure	19	19	19	19	19	C	C	55	None
Maximum Lot Coverage	Principal & Accessory Structures (% of gross lot area)	90	80	80	100	80	None	None	None	None

Foot Notes:

- A There shall be no less than ten (10) feet between any structures
- B When adjoining a business or industrial district, the minimum setback shall be zero. When adjoining any other district, the minimum setback shall be equal to that of the adjoining district
- C There shall be no height limit provided that for every foot in height the structure is over 19', the side and rear setbacks shall increase one foot
- D In any major or minor, residential, business or industrial subdivision, any valid setbacks or other developmental standards incorporated on the recorded plat or within the covenants and restrictions apply. In all other cases, county setbacks and developmental standards apply
- E For additional setback requirements, refer to the White County Zoning Ordinance, Section 3.14
- F Applies to the ground floor level of the principal structure
- G Setback is waived in situations where a rear or side property line are subject to common ownership or which abutt an SFLECC property line.

Additional Foot Notes:

- 1 Any deck built on a property which has the waterside as its front lot line shall be allowed a zero front setback for a deck only
- 2 Any lot determined to be in a lake area which has a property line abutting a road shall require the applicable property line meet a 20' foot minimum setback

Amended: 03/21/2022 Ordinance #22-03-21-01

Table C.1: Trees approved for planting along public rights-of-way and in locations where low maintenance, hardy species with high canopies are required

Botanic Name	Common Name	Height	Tree Category
<i>Acer campestre</i>	Hedge Maple	30'-40'	Ornamental
<i>Acer Freemanii</i>	Freeman Maple	50-60'	Shade
<i>Acer rubrum</i>	Red Maple	50-60'	Shade
<i>Acer saccharum</i>	Sugar Maple	50-70'	Shade
<i>Acer tataricum</i>	Tatarian Maple	20-25'	Ornamental
<i>Acer truncatum x acer platanoides</i>	Sunset Shantung Hybrid Maple	30-40'	Shade
<i>Carpinus betulus 'Fastigiata'</i>	Upright European Hornbeam	30-40'	Ornamental
<i>Carpinus caroliniana</i>	American Hornbeam	25-30'	Ornamental
<i>Celtis occidentalis</i>	Hackberry	50-75'	Shade
<i>Cercis canadensis</i>	Eastern Redbud	20-25'	Ornamental
<i>Cladrastis lutea</i>	Yellowwood	35-55'	Shade
<i>Crataegus crus-galli var. inermis</i>	Thornless Cockspur Hawthorn	15-25'	Ornamental
<i>Crataegus phaenopyrum</i>	Washington Hawthorn	20-25'	Ornamental
<i>Crataegus viridis 'Winter King'</i>	Winter King Hawthorn	15-25'	Ornamental
<i>Eucommia ulmoides</i>	Hardy Rubber Tree	40-60'	Shade
<i>Fraxinus americana</i>	White Ash	45-65'	Shade
<i>Fraxinus pennsylvanica</i>	Green Ash	40-50'	Shade
<i>Ginkgo biloba</i>	Ginkgo	40-60'	Shade
<i>Gleditzia tricanthos inermis</i>	Thornless Honeylocust	40-45'	Shade
<i>Koelreuteria paniculata</i>	Golden Rain Tree	20-35'	Ornamental
<i>Liquidambar styraciflua</i>	American Sweet Gum	40-60'	Shade
<i>Malus hybrids</i>	Flowering Crabapple	15-30'	Ornamental
<i>Metasequois glyptostroboides</i>	Dawn Redwood	50-70'	Shade
<i>Nyssa sylvatica</i>	Black Gum	40-70'	Shade
<i>Platanus x acerfolia 'Bloodgood'</i>	Bloodgood London Planetree	50-70'	Shade
<i>Prunus 'Accolade'</i>	Accolade Flowering Cherry	30-40'	Ornamental
<i>Prunus 'Newport'</i>	Newport Plum	15-20'	Ornamental
<i>Prunus maackii</i>	Amur Chokecherry	25-30'	Ornamental
<i>Prunus sargentii 'Columnaris'</i>	Columnar Sargent Cherry	30-40'	Ornamental
<i>Prunus virginiana</i>	Chokecherry	20-25'	Ornamental
<i>Pyrus calleryana</i>	Ornamental Pear	20-25'	Ornamental
<i>Quercus acutissima</i>	Sawtooth Oak	40-50'	Shade
<i>Quercus coccinea</i>	Scarlet Oak	60-80'	Shade
<i>Quercus imbricaria</i>	Shingle Oak	40-65'	Shade
<i>Quercus macrocarpa</i>	Bur Oak	50-80'	Shade
<i>Quercus palustris</i>	Pin Oak	50-80'	Shade
<i>Quercus phellos</i>	Willow Oak	50-70'	Shade
<i>Quercus robur</i>	English Oak	50-70'	Shade
<i>Quercus rubra</i>	Red Oak	40-60'	Shade
<i>Quercus shumardii</i>	Shumard Oak	50-70'	Shade
<i>Tilia americana</i>	American Linden	40-60'	Shade
<i>Tilia cordata</i>	Little-Leaf Linden	40-50'	Shade
<i>Tilia tomentosa</i>	Silver Linden	40-50'	Shade
<i>Zelkova serrata 'Village Green'</i>	Village Green Zelkova	40-60'	Shade

Table C.2: Trees approved for use within the interior of a site

Botanic Name	Common Name	Height	Tree Category
Acer ginalla	Amur Maple	15-20'	Ornamental
Acer griseum	Paperbark Maple	20-30'	Ornamental
Acer palmatum	Japanese Maple	15-20'	Ornamental
Acer platanoides	Norway Maple	40'-70'	Shade
Amelachier canadensis	Serviceberry	30-35'	Ornamental
Amelachier x grandiflora	Serviceberry	25-30'	Ornamental
Amelchier laevis	Allegheny Serviceberry	25-30'	Ornamental
Betula nigra	River Birch	30-40'	Ornamental
Betula papyrifera	Paper Birch	30-40'	Ornamental
Cercidyphyllum japonicum	Katsura Tree	25-40'	Ornamental
Cornus kousa	Japanese Dogwood	20-25'	Ornamental
Cotinus coggyria	Smoke Tree	15-20'	Ornamental
Corataegus laevigata	English Hawthorn	15-20'	Ornamental
Gymnocladus dioicus	Kentucky Coffee Tree	40-50'	Shade
Liriodendron tulipifera	Tulip Tree	60-80'	Shade
Magnolia acuminata	Cucumbertree Magnolia	50-70'	Shade
Magnolia x loebneri	Magnolia	20-30'	Ornamental
Magnolia soulangiana	Saucer Magnolia	15-20'	Ornamental
Magnolia stellata	Star Magnolia	10-15'	Ornamental
Ostrya virginiana	American Hophornbeam	30-40'	Shade
Phellodendron amurense	Amur Corktree	35-45'	Shade
Picea abies	Norway Spruce	50-60'	Evergreen
Picea glauca densata	Black Hills Spruce	50-60'	Evergreen
Picea pungens	Colorado Spruce	60-75'	Evergreen
Picea pungens 'Glauca'	Colorada Blue Spruce	60-75'	Evergreen
Pinus nigra	Austrian Pine	30-60'	Evergreen
Pinus ponderosa	Ponderosa Pine	40-50'	Evergreen
Pinus strobus	Eastern White Pine	50-100'	Evergreen
Prunus serrulata	Oriental Cherry	25-35'	Ornamental
Quercus alba	White Oak	60-80'	Shade
Quercus bicolor	Swamp White Oak	40-50'	Shade
Salix Species	Weeping Willow	25-50'	Shade
Taxodium distichum	Baldcypress	60-80'	Shade
Tsuga canadensis	Canada Hemlock	60-75'	Evergreen

Note: Ash species should be planted in moderation and should not be planted in monocultures, due to the risks of the emerald ash borer infestation.

Table C.3: Upright shrubs approved for screening, hedges, and other plantings

Botanic Name	Common Name	Height
<i>Aronia melanocarpa</i>	Black Chokeberry	4-6'
<i>Berberis thunbergii</i> Hybrids	Japanese Barberry	3-5'
<i>Buddleia davidii</i>	Butterfly Bush	5-8'
<i>Buxus microphylla</i>	Littleleaf Boxwood	2-3'
<i>Buxus x koreana</i> hybrids	Sheridan Hybrid Boxwood	2-4'
<i>Caryopteris x clandonensis</i>	Blue Mist Spirea	3'
<i>Chaenomeles</i> species	Flowering Quince	2-6'
<i>Clethra alnifolia</i>	Summersweet	3-6'
<i>Cornus alba</i>	Variegated Red Twig Dogwood	6-10'
<i>Cornus alternifolia</i>	Pagoda Dogwood	15-20'
<i>Cornus sericea</i>	Redtwig Dogwood	8-10'
<i>Cotinus coggygia</i>	Smoke Tree	8-10'
<i>Cotoneaster apiculata</i>	Cranberry Cotoneaster	4-8'
<i>Cotoneaster divaricata</i>	Spreading Cotoneaster	5-6'
<i>Euonymus alatus</i>	Burning Bush	7-10'
<i>Euonymus fortunei</i>	Euonymous	4-6'
<i>Forsythia intermedia</i> Hybrids	Hybrid Forsythia	7-10'
<i>Hamamelis virginiana</i>	Common Witch Hazel	10-15'
<i>Hibiscus syriacus</i>	Rose of Sharon	4-12'
<i>Hydrangea arborescens</i> 'Annabelle'	Annabelle Hydrangea	4-15'
<i>Hydrangea macrophylla</i> hybrids	Bigleaf Hydrangea	3-5'
<i>Hydrangea paniculata</i> hybrids	Panicle Hydrangea	6-10'
<i>Hydrangea quercifolia</i>	Oakleaf Hydrangea	5-10'
<i>Ilex crenata</i>	Japanese Holly	3-5'
<i>Ilex glabra</i>	Inkberry	3-6'
<i>Ilex meserveae</i>	Blue Holly	6-8'
<i>Ilex verticillata</i>	Winterberry	6-9'
<i>Itea virginica</i>	Sweetspire	3-5'
<i>Juniperus chinensis</i>	Chinese Juniper	6-15'
<i>Juniperus scopulorum</i>	Rocky Mountain Juniper	6-15'
<i>Ligustrum amurense</i>	Amur Privet	4-8'
<i>Ligustrum 'Vicary'</i>	Golden Vicary Privet	4-12'
<i>Mahonia aquifolium</i>	Oregon Grape Holly	3-6'
<i>Myrica pennsylvanica</i>	Northern Bayberry	8-10'
<i>Philadelphus coronarius</i>	Sweet Mockorange	8-10'
<i>Physocarpus opulifolius</i> <i>intermedius</i>	Dwarf Ninebark	4-5'
<i>Picea abies</i>	Dwarf varieties of Norway Spruce	2-5'
<i>Picea glauca conica</i>	Dwarf Alberta Spruce	6-10'
<i>Pinus mugo</i>	Mugho Pine	3-6'
<i>Potentilla fruticosa</i>	Potentilla	2-3'
<i>Prunus cistena</i>	Cistena Plum	6-8'
<i>Prunus glandulosa</i>	Dwarf Flowering Almond	4-6'
<i>Prunus triloba</i>	Flowering Almond	8-10'
<i>Pyracantha</i>	Scarlet Firethorn	5-15'
<i>Rhamnus frangula</i>	Alder Buckthorn	12-15'
<i>Rhus aromatica</i>	Fragment Sumac	4-6'

Botanic Name	Common Name	Height
<i>Rhus glabra</i>	Smooth Sumac	8-10'
<i>Rhus typhina</i>	Staghorn Sumac	8-12'
<i>Salix caprea</i>	French Pussy Willow	15-20'
<i>Sambucus nigra</i>	European Elderberry	6-12'
<i>Spiraea hybrids</i>	Spirea	2-8'
<i>Syringa chinensis</i>	Chinese Lilac	6-8'
<i>Syringa meyeri</i> 'Palibin'	Dwarf Korean Lilac	5'
<i>Syringa patula</i> 'Miss Kim'	Miss Kim Lilac	4-6'
<i>Syringa vulgaris</i>	Common Lilac	8-12'
<i>Syringa vulgaris</i> Hybrids	Hybrid French Lilac	8-12'
<i>Taxus cuspidata</i>	Upright or Columnar Japanese Yew	10-25'
<i>Taxus x media</i>	Spreading and Upright Yew	2-12'
<i>Taxus</i> 'Hicksi'	Hick's Yew	10-12'
<i>Thuja occidentalis</i> Hybrids	American Arborvitae	4-15'
<i>Viburnum carlesii</i>	Korean spice Viburnum	4-6'
<i>Viburnum dentatum</i>	Arrowwood Viburnum	10-15'
<i>Viburnum lantana</i>	Wayfaring Tree	8-15'
<i>Viburnum lantago</i>	Nannyberry	8-15'
<i>Viburnum opulus</i>	European Cranberry Bush	10-12'
<i>Viburnum plicatum tomentosum</i>	Doublefile Viburnum	8-10'
<i>Viburnum prunifolium</i>	Black Haw Viburnum	10-12'
<i>Viburnum x rhytidophylloides</i>	Leatherleaf Viburnum	6-15'
<i>Viburnum trilobum</i>	American Cranberry Bush	8-12'
<i>Weigela florida</i>	Flowering Weigela	4-5'
<i>Weigela vaniceki</i>	Cardinal Shrub	4-5'

Table C.4: Spreading shrubs approved for low borders and ground covers

Botanic Name	Common Name	Height
Ajuga	Bugleweed	6-8"
Berberis mentorensis	Mentor Barberry	3-4'
Berberis thunbergii Hybrids	Japanese Barberry	2-4'
Buxus x koreana hybrids	Sheridan Hybrid Boxwood	2-4'
Caryopteris x clandonensis	Blue Mist Spirea	3'
Clethera alnifolia 'Hummingbird'	Hummingbird Summersweet	3-5'
Cotoneaster apiculata	Cranberry Cotoneaster	2-3'
Cotoneaster horizontalis	Rockspray Cotoneaster D	1-3'
Daphne burkwoodii	Burkwood Daphne	3-4'
Duetzia gracilis	Slender Duetzia	2-3'
Euonymus fortunei 'Coloratus'	Purpleleaf wintercreeper	6-8"
Forsythia viridissima 'Bronxensis'	Dwarf Forsythia	1-2'
Hedera helix	English Ivy	6-8"
Hypericon patulum	St. John's Wort	2-3'
Ilex glabra 'Shamrock'	Shamrock Compact inkberry	
Juniperus (spreading varieties)	Juniper	1-3'
Mohonia aquifolium 'Compacta'	Dwarf Oregon Grape	2'
Microbiota decussata	Siberian Cypress	1'
Pacchysandra terminalis	Japanese Spurge	6-8"
Picea abies 'Elegans'	Elegans Dwarf Norway Spruce	3'
Picea abies 'Little Gem'	Little /Gem Spruce	3'
Picea abies 'Nidformis'	Birdnest Spruce	2'
Picea abies 'Pumila'	Dwarf Norway Spruce	2-3'
Picea pungens glauca 'Globosa'	Blue Globe Spruce	3-4'
Picea mariana 'Nana'	Blue Newt Spruce	3'
Pinus mugo	Mugho Pine	3-4'
Potentilla fruticosa Hybrids	Bush Cinqufoil	2-3'
Rhus aromatica 'Low Grow'	Low Grow Fragrant Sumac	1-2'
Ribes alpinum	Alpine Currant	3-5'
Spirea x bumalda	Spirea	2-3'
Spirea japonica	Japanese Spirea	2-3'
Spirea nipponica	Nippon Spirea	2-3'
Syringa patula 'Miss Kim'	Dwarf Korean Lilac	3-5'
Taxus cupidata 'Nana'	Dwarf Japanese Yew	2-3'
Taxus media (spreading)	Spreading Yew	2-4'
Thuja occidentalis 'Hetzil Midget'	Hetz Midget Arborvitae	2-3'
Thuja occidentalis 'Rheingold'	Rheingold Arborvitae	3'
Viburnum opulus 'Nana'	European Cranberry Bush	1-2'
Vinca minor	Periwinkle	6"

Table C.5: Vines for Walls and Fences

Botanic Name	Common Name
Aristolochia durior	Dutchmans's Pipe
Campsis radicans	Trumpet Creeper
Clematis	Clematis Hybrids
Hydrangea anomola	Climbing Hydrangeas
Lonicera x brownii	Dropmore Scarlet Honeysuckle
Lonicera x heckrottii	Goldflame Honeysuckle
Parthenocissus quinquefolia	Virginia Creeper
Parthenocissus tricuspidata	Boston Ivy
Wisteria floribunda	Japanese Wisteria

APPENDIX D PROCESS CHARTS

Appendix E
REGULATIONS FOR FLOOD HAZARD AREAS
FOR WHITE COUNTY

Article 1. Statutory Authorization, Findings of Fact, Purpose, and Objectives.

Section A. Statutory Authorization.

The Indiana Legislature has in IC 36-7-4 and IC 14-28-4 granted the power to local government units to control land use within their jurisdictions.

Section B. Findings of Fact.

- (1) The flood hazard areas of White County, City of Monticello, Town of Monon, Town of Chalmers, Town of Reynolds, Town of Wolcott and Town of Brookston, hereinafter referred to as the County, are subject to periodic inundation which results in loss of life and property, health and safety hazards, disruption of commerce and governmental services, extraordinary public expenditures for flood protection and relief, and impairment of the tax base, all of which adversely affect the public health, safety, and general welfare.
- (2) These flood losses are caused by the cumulative effect of obstructions in floodplains causing increases in flood heights and velocities, and by the occupancy in flood hazard areas by uses vulnerable to floods or hazardous to other lands which are inadequately elevated, flood-proofed, or otherwise unprotected from flood damages.

Section C. Statement of Purpose.

It is the purpose of these regulations to promote the public health, safety, and general welfare and to minimize public and private losses due to flood conditions in specific areas by provisions designed to:

- (1) Restrict or prohibit uses which are dangerous to health, safety, and property due to water or erosion hazards, which result in damaging increases in erosion or in flood heights or velocities.
- (2) Require that uses vulnerable to floods, including facilities which serve such uses, be protected against flood damage at the time of initial construction.
- (3) Control the alteration of natural floodplains, stream channels, and natural protective barriers which are involved in the accommodation of flood waters.
- (4) Control filling, grading, dredging, and other development which may increase erosion or flood damage.
- (5) Prevent or regulate the construction of flood barriers which will unnaturally divert floodwaters or which may increase flood hazards to other lands.
- (6) Make federally subsidized flood insurance available for structures and their contents in the County by fulfilling the requirements of the National Flood Insurance Program.

Section D. Objectives.

The objectives of these regulations are:

- (1) To protect human life and health.
- (2) To minimize expenditure of public money for costly flood control projects.
- (3) To minimize the need for rescue and relief efforts associated with flooding and generally undertaken at the expense of the general public.
- (4) To minimize prolonged business interruptions.
- (5) To minimize damage to public facilities and utilities such as water and gas mains, electric, telephone, and sewer lines, streets, and bridges located in floodplains.
- (6) To help maintain a stable tax base by providing for the sound use and development of flood prone areas in such a manner as to minimize flood blight areas.
- (7) To ensure that potential homebuyers are notified that property is in a flood area.

Article 2. Definitions.

Unless specifically defined below, words or phrases used in these regulations shall be interpreted so as to give them the meaning they have in the White County Indiana Zoning and Subdivision Control Ordinances and to give these regulations their most reasonable application.

A zone means portions of the SFHA in which the principal source of flooding is runoff from rainfall, snowmelt, or a combination of both. In A zones, floodwaters may move slowly or rapidly, but waves are usually not a significant threat to buildings. These areas are labeled as Zone A, Zone AE, Zones A1-A30, Zone AO, Zone AH, Zone AR and Zone A99 on a FIRM or FHBM. The definitions are presented below:

Zone A: Areas subject to inundation by the one-percent annual chance flood event. Because detailed hydraulic analyses have not been performed, no base flood elevation or depths are shown. Mandatory flood insurance purchase requirements apply.

Zone AE and A1-A30: Areas subject to inundation by the one-percent annual chance flood event determined by detailed methods. Base flood elevations are shown within these zones. Mandatory flood insurance purchase requirements apply. (Zone AE is on new and revised maps in place of Zones A1-A30.)

Zone AO: Areas subject to inundation by one-percent annual chance shallow flooding (usually sheet flow on sloping terrain) where average depths are between one and three feet. Average flood depths derived from detailed hydraulic analyses are shown within this zone. Mandatory flood insurance purchase requirements apply.

Zone AH: Areas subject to inundation by one-percent annual chance shallow flooding (usually areas of ponding) where average depths are between one and three feet. Average flood depths derived from detailed hydraulic analyses are shown within this zone. Mandatory flood insurance purchase requirements apply.

Zone AR: Areas that result from the decertification of a previously accredited flood protection system that is determined to be in the process of being restored to provide base flood protection. Mandatory flood insurance purchase requirements apply.

Zone A99: Areas subject to inundation by the one-percent annual chance flood event, but which will ultimately be protected upon completion of an under-construction Federal flood protection system. These are areas of special flood hazard where enough progress has been made on the construction of a protection system, such as dikes, dams, and levees, to consider it complete for insurance rating purposes. Zone A99 may only be used when the flood protection system has reached specified statutory progress toward completion. No base flood elevations or depths are shown. Mandatory flood insurance purchase requirements apply.

Accessory structure (appurtenant structure) means a structure that is located on the same parcel of property as the principal structure and the use of which is incidental to the use of the principal structure. Accessory structures should constitute a minimal initial investment, may not be used for human habitation, and be designed to have minimal flood damage potential. Examples of accessory structures are detached garages, carports, storage sheds, pole barns, and hay sheds.

Addition (to an existing structure) means any walled and roofed expansion to the perimeter of a structure in which the addition is connected by a common load-bearing wall other than a firewall. Any walled and roofed addition, which is connected by a firewall or is separated by independent perimeter load-bearing walls, is new construction.

Appeal means a request for a review of the floodplain administrator's interpretation of any provision of these regulations or a request for a variance.

Area of shallow flooding means a designated AO or AH Zone on the community's Flood Insurance Rate Map (FIRM) with base flood depths from one to three feet where a clearly defined channel does not exist, where the path of flooding is unpredictable and indeterminate, and where velocity flow may be evident. Such flooding is characterized by ponding or sheet flow.

Base Flood Elevation (BFE) means the elevation of the one-percent annual chance flood.

Basement means that portion of a structure having its floor sub-grade (below ground level) on all sides.

Building - see "Structure."

Community means a political entity that has the authority to adopt and enforce floodplain ordinances for the area under its jurisdiction.

Community Rating System (CRS) means a program developed by the Federal Insurance Administration to provide incentives for those communities in the Regular Program that have gone beyond the minimum floodplain management requirements to develop extra measures to provide protection from flooding.

Critical facility means a facility for which even a slight chance of flooding might be too great. Critical facilities include, but are not limited to, schools, nursing homes, hospitals, police, fire, and emergency response installations, installations which produce, use or store hazardous materials or hazardous waste.

Development means any man-made change to improved or unimproved real estate including but not limited to:

- (1) construction, reconstruction, or placement of a structure or any addition to a structure;
- (2) installing a manufactured home on a site, preparing a site for a manufactured home or installing a recreational vehicle on a site for more than 180 days;
- (3) installing utilities, erection of walls and fences, construction of roads, or similar projects;

- (4) construction of flood control structures such as levees, dikes, dams, channel improvements, etc.;
- (5) mining, dredging, filling, grading, excavation, or drilling operations;
- (6) construction and/or reconstruction of bridges or culverts;
- (7) storage of materials; or
- (8) any other activity that might change the direction, height, or velocity of flood or surface waters.

"Development" does not include activities such as the maintenance of existing structures and facilities such as painting, re-roofing; resurfacing roads; or gardening, plowing, and similar agricultural practices that do not involve filling, grading, excavation, or the construction of permanent structures.

Elevated structure means a non-basement structure built to have the lowest floor elevated above the ground level by means of fill, solid foundation perimeter walls, filled stem wall foundations (also called chain walls), pilings, or columns (posts and piers).

Elevation Certificate is a certified statement that verifies a structure's elevation information.

Emergency Program means the first phase under which a community participates in the NFIP. It is intended to provide a first layer amount of insurance at subsidized rates on all insurable structures in that community before the effective date of the initial FIRM.

Encroachment means the advance or infringement of uses, fill, excavation, buildings, permanent structures or development into a floodplain, which may impede or alter the flow capacity of a floodplain.

Existing Construction means any structure for which the "start of construction" commenced before the effective date of the community's first floodplain ordinance.

Existing manufactured home park or subdivision means a manufactured home park or subdivision for which the construction of facilities for servicing the lots on which the manufactured homes are to be affixed (including, at a minimum, the installation of utilities, the construction of streets, and either final site grading or the pouring of concrete pads) is completed before the effective date of the community's first floodplain ordinance.

Expansion to an existing manufactured home park or subdivision means the preparation of additional sites by the construction of facilities for servicing the lots on which the manufactured homes are to be affixed (including the installation of utilities, the construction of streets, and either final site grading or the pouring of concrete pads).

FEMA means the Federal Emergency Management Agency.

Five-hundred year flood (500-year flood) means the flood that has a 0.2 percent chance of being equaled or exceeded in any year.

Flood means a general and temporary condition of partial or complete inundation of normally dry land areas from the overflow, the unusual and rapid accumulation, or the runoff of surface waters from any source.

Flood Boundary and Floodway Map (FBFM) means an official map on which the Federal Emergency Management Agency (FEMA) or Federal Insurance Administration (FIA) has delineated the areas of flood hazards and regulatory floodway.

Flood Hazard Boundary Map (FHBM) means an official map of a community, issued by FEMA, where the boundaries of the areas of special flood hazard have been identified as Zone A.

Flood Insurance Rate Map (FIRM) means an official map of a community, on which FEMA has delineated both the areas of special flood hazard and the risk premium zones applicable to the community.

Flood Insurance Study (FIS) is the official hydraulic and hydrologic report provided by FEMA. The report contains flood profiles, as well as the FIRM, FBFM (where applicable), and the water surface elevation of the base flood.

Flood Prone Area means any land area acknowledged by a community as being susceptible to inundation by water from any source. (See "Flood")

Flood Protection Grade (FPG) is the elevation of the regulatory flood plus two feet at any given location in the SFHA (see "Freeboard").

Floodplain means the channel proper and the areas adjoining any wetland, lake, or watercourse which have been or hereafter may be covered by the regulatory flood. The floodplain includes both the floodway and the fringe districts.

Floodplain management means the operation of an overall program of corrective and preventive measures for reducing flood damage and preserving and enhancing, where possible, natural resources in the floodplain, including but not limited to emergency preparedness plans, flood control works, floodplain management regulations, and open space plans.

Floodplain management regulations means these regulations and other zoning ordinances, subdivision regulations, building codes, health regulations, special purpose ordinances, and other applications of police power which control development in flood-prone areas. This term describes federal, state, or local regulations in any combination thereof, which provide standards for preventing and reducing flood loss and damage. Floodplain management regulations are also referred to as floodplain regulations, floodplain ordinance, flood damage prevention ordinance, and floodplain management requirements.

Floodproofing (dry floodproofing) is a method of protecting a structure that ensures that the structure, together with attendant utilities and sanitary facilities, is watertight to the floodproofed design elevation with walls that are substantially impermeable to the passage of water. All structural components of these walls are capable of resisting hydrostatic and hydrodynamic flood forces, including the effects of buoyancy, and anticipated debris impact forces.

Floodproofing certificate is a form used to certify compliance for non-residential structures as an alternative to elevating structures to or above the FPG. This certification must be by a Registered Professional Engineer or Architect.

Floodway is the channel of a river or stream and those portions of the floodplains adjoining the channel which are reasonably required to efficiently carry and discharge the peak flood flow of the regulatory flood of any river or stream.

Freeboard means a factor of safety, usually expressed in feet above the BFE, which is applied for the purposes of floodplain management. It is used to compensate for the many unknown factors that could contribute to flood heights greater than those calculated for the base flood.

Fringe is those portions of the floodplain lying outside the floodway.

Functionally dependent facility means a facility which cannot be used for its intended purpose unless it is located or carried out in close proximity to water, such as a docking or port facility necessary for the

loading and unloading of cargo or passengers, shipbuilding, ship repair, or seafood processing facilities. The term does not include long-term storage, manufacture, sales, or service facilities.

Hardship (as related to variances of these regulations) means the exceptional hardship that would result from a failure to grant the requested variance. The White County Area Board of Commissioners requires that the variance is exceptional, unusual, and peculiar to the property involved. Mere economic or financial hardship alone is NOT exceptional. Inconvenience, aesthetic considerations, physical handicaps, personal preferences, or the disapproval of one's neighbors likewise cannot, as a rule, qualify as an exceptional hardship. All of these problems can be resolved through other means without granting a variance, even if the alternative is more expensive, or requires the property owner to build elsewhere or put the parcel to a different use than originally intended.

Highest adjacent grade means the highest natural elevation of the ground surface, prior to the start of construction, next to the proposed walls of a structure.

Historic structure means any structure individually listed on the National Register of Historic Places or the Indiana State Register of Historic Sites and Structures.

Increased Cost of Compliance (ICC) means the cost to repair a substantially damaged structure that exceeds the minimal repair cost and that is required to bring a substantially damaged structure into compliance with the local flood damage prevention ordinance. Acceptable mitigation measures are elevation, relocation, demolition, or any combination thereof. All renewal and new business flood insurance policies with effective dates on or after June 1, 1997, will include ICC coverage.

Letter of Map Amendment (LOMA) means an amendment to the currently effective FEMA map that establishes that a property is not located in a SFHA. A LOMA is only issued by FEMA.

Letter of Map Revision (LOMR) means an official revision to the currently effective FEMA map. It is issued by FEMA and changes flood zones, delineations, and elevations.

Letter of Map Revision Based on Fill (LOMR-F) means an official revision by letter to an effective NFIP map. A LOMR-F provides FEMA's determination concerning whether a structure or parcel has been elevated on fill above the BFE and excluded from the SFHA.

Lowest adjacent grade means the lowest elevation, after completion of construction, of the ground, sidewalk, patio, deck support, or basement entryway immediately next to the structure.

Lowest floor means the lowest of the following:

- (1) the top of the lowest level of the structure;
- (2) the top of the basement floor;
- (3) the top of the garage floor, if the garage is the lowest level of the structure;
- (4) the top of the first floor of a structure elevated on pilings or pillars;
- (5) the top of the floor level of any enclosure, other than a basement, below an elevated structure where the walls of the enclosure provide any resistance to the flow of flood waters unless:
 - a. the walls are designed to automatically equalize the hydrostatic flood forces on the walls by allowing for the entry and exit of flood waters by providing a minimum of two openings (in addition to doorways and windows) in a minimum of two exterior walls having a total net area of one (1) square inch for every one square foot of enclosed area. The bottom of all such openings shall be no higher than one (1) foot above the exterior grade or the interior grade immediately beneath each opening, whichever is higher; and,

- b. such enclosed space shall be usable solely for the parking of vehicles and building access.

Manufactured home means a structure, transportable in one or more sections, which is built on a permanent chassis and is designed for use with or without a permanent foundation when attached to the required utilities. The term "manufactured home" does not include a "recreational vehicle."

Manufactured home park or subdivision means a parcel (or contiguous parcels) of land divided into two or more manufactured home lots for rent or sale.

Map amendment means a change to an effective NFIP map that results in the exclusion from the SFHA of an individual structure or a legally described parcel of land that has been inadvertently included in the SFHA (i.e., no alterations of topography have occurred since the date of the first NFIP map that showed the structure or parcel to be within the SFHA).

Map panel number is the four-digit number followed by a letter suffix assigned by FEMA on a flood map. The first four digits represent the map panel, and the letter suffix represents the number of times the map panel has been revised. (The letter "A" is not used by FEMA, the letter "B" is the first revision.)

Market value means the building value, excluding the land (as agreed to between a willing buyer and seller), as established by what the local real estate market will bear. Market value can be established by independent certified appraisal, replacement cost depreciated by age of building (actual cash value), or adjusted assessed values.

Mitigation means sustained actions taken to reduce or eliminate long-term risk to people and property from hazards and their effects. The purpose of mitigation is two fold: to protect people and structures, and to minimize the cost of disaster response and recovery.

National Flood Insurance Program (NFIP) is the federal program that makes flood insurance available to owners of property in participating communities nationwide through the cooperative efforts of the Federal Government and the private insurance industry.

National Geodetic Vertical Datum (NGVD) of 1929 as corrected in 1929 is a vertical control used as a reference for establishing varying elevations within the floodplain.

New construction means any structure for which the "start of construction" commenced after the effective date of the community's first floodplain ordinance.

New manufactured home park or subdivision means a manufactured home park or subdivision for which the construction of facilities for servicing the lots on which the manufactured homes are to be affixed (including at a minimum, the installation of utilities, the construction of streets, and either final site grading or the pouring of concrete pads) is completed on or after the effective date of the community's first floodplain ordinance.

North American Vertical Datum of 1988 (NAVD 88) as adopted in 1993 is a vertical control datum used as a reference for establishing varying elevations within the floodplain.

Obstruction includes, but is not limited to, any dam, wall, wharf, embankment, levee, dike, pile, abutment, protection, excavation, canalization, bridge, conduit, culvert, building, wire, fence, rock, gravel, refuse, fill, structure, vegetation, or other material in, along, across or projecting into any watercourse which may alter, impede, retard or change the direction and/or velocity of the flow of water; or due to its location, its propensity to snare or collect debris carried by the flow of water, or its likelihood of being carried downstream.

One-hundred year flood (100-year flood) is the flood that has a one percent (1%) chance of being equaled or exceeded in any given year. Any flood zone that begins with the letter A is subject to the one-percent annual chance flood. See "Regulatory Flood".

One-percent annual chance flood is the flood that has a one percent (1%) chance of being equaled or exceeded in any given year. Any flood zone that begins with the letter A is subject to the one-percent annual chance flood. See "Regulatory Flood".

Participating community is any community that voluntarily elects to participate in the NFIP by adopting and enforcing floodplain management regulations that are consistent with the standards of the NFIP.

Physical Map Revision (PMR) is an official republication of a community's FEMA map to effect changes to base (1-percent annual chance) flood elevations, floodplain boundary delineations, regulatory floodways, and planimetric features. These changes typically occur as a result of structural works or improvements, annexations resulting in additional flood hazard areas, or correction to base flood elevations or SFHAs.

Post-FIRM construction means construction or substantial improvement that started on or after the effective date of the initial FIRM of the community or after December 31, 1974, whichever is later.

Pre-FIRM construction means construction or substantial improvement, which started on or before December 31, 1974, or before the effective date of the initial FIRM of the community, whichever is later.

Probation is a means of formally notifying participating communities of violations and deficiencies in the administration and enforcement of the local floodplain management regulations.

Public safety and nuisance means anything which is injurious to the safety or health of an entire community, neighborhood or any considerable number of persons, or unlawfully obstructs the free passage or use, in the customary manner, of any navigable lake, or river, bay, stream, canal, or basin.

Recreational vehicle means a vehicle which is (1) built on a single chassis; (2) 400 square feet or less when measured at the largest horizontal projections; (3) designed to be self-propelled or permanently towable by a light duty truck; and (4) designed primarily not for use as a permanent dwelling, but as quarters for recreational camping, travel, or seasonal use.

Regular program means the phase of the community's participation in the NFIP where more comprehensive floodplain management requirements are imposed and higher amounts of insurance are available based upon risk zones and elevations determined in a FIS.

Regulatory flood means the flood having a one percent (1%) chance of being equaled or exceeded in any given year, as calculated by a method and procedure that is acceptable to and approved by the Indiana Department of Natural Resources and the Federal Emergency Management Agency. The regulatory flood elevation at any location is as defined in Article 3 (B) of these regulations. The "Regulatory Flood" is also known by the term "Base Flood", "One-Percent Annual Chance Flood", and "100-Year Flood".

Repetitive loss means flood-related damages sustained by a structure on two separate occasions during a 10-year period ending on the date of the event for which the second claim is made, in which the cost of repairing the flood damage, on the average, equaled or exceeded 25% of the market value of the structure at the time of each such flood event.

Section 1316 is that section of the National Flood Insurance Act of 1968, as amended, which states that no new flood insurance coverage shall be provided for any property that the Administrator finds has been declared by a duly constituted state or local zoning authority or other authorized public body to be in violation of state or local laws, regulations, or ordinances that intended to discourage or otherwise restrict land development or occupancy in flood-prone areas.

Special Flood Hazard Area (SFHA) means those lands within the jurisdictions of the County subject to inundation by the regulatory flood. The SFHAs of the County are generally identified as such on the White County, Indiana and Incorporated Areas Flood Insurance Rate Map prepared by the Federal Emergency Management Agency, dated January 8, 2014 as well as any future updates, amendments, or revisions, prepared by the Federal Emergency Management Agency with the most recent date. The SFHAs of those parts of unincorporated White County that are within the extraterritorial jurisdiction of the City of Monticello, Town of Brookston, Town of Chalmers, Town of Reynolds, Town of Monon or the Town of Wolcott or that may be annexed into the City of Monticello, Town of Brookston, Town of Chalmers, Town of Reynolds, Town of Monon or the Town of Wolcott are generally identified as such on the White County, Indiana and Incorporated Areas Flood Insurance Rate Map prepared by the Federal Emergency Management Agency, dated January 8, 2014 prepared by the Federal Emergency Management Agency and dated January 8, 2014 as well as any future updates, amendments, or revisions, prepared by the Federal Emergency Management Agency with the most recent date. (These areas are shown on a FHBM or FIRM as Zone A, AE, A1- A30, AH, AR, A99, or AO).

Start of construction includes substantial improvement, and means the date the building permit was issued, provided the actual start of construction, repair, reconstruction, or improvement was within 180 days of the permit date. The actual start means either the first placement of permanent construction of a structure on a site, such as the pouring of a slab or footings, the installation of piles, the construction of columns, or any work beyond the stage of excavation; or the placement of a manufactured home on a foundation. Permanent construction does not include land preparation, such as clearing, grading and filling; nor does it include the installation of streets and/or walkways; nor does it include excavation for a basement, footings, piers, foundations, or the erection of temporary forms; nor does it include the installation on the property of accessory buildings, such as garages or sheds not occupied as dwelling units or not part of the main structure. For a substantial improvement, the actual start of construction means the first alteration of any wall, ceiling, floor, or other structural part of a building, whether or not that alteration affects the external dimensions of the building.

Structure means a structure that is principally above ground and is enclosed by walls and a roof. The term includes a gas or liquid storage tank, a manufactured home, or a prefabricated building. The term also includes recreational vehicles to be installed on a site for more than 180 days.

Substantial damage means damage of any origin sustained by a structure whereby the cost of restoring the structure to its before damaged condition would equal or exceed 50 percent of the market value of the structure before the damage occurred.

Substantial improvement means any reconstruction, rehabilitation, addition, or other improvement of a structure, the cost of which equals or exceeds 50 percent of the market value of the structure before the "start of construction" of the improvement. This term includes structures that have incurred "repetitive loss" or "substantial damage" regardless of the actual repair work performed. The term does not include improvements of structures to correct existing violations of state or local health, sanitary, or safety code requirements or any alteration of a "historic structure", provided that the alteration will not preclude the structures continued designation as a "historic structure".

Suspension means the removal of a participating community from the NFIP because the community has not enacted and/or enforced the proper floodplain management regulations required for participation in the NFIP.

Variance is a grant of relief from the requirements of these regulations, which permits construction in a manner otherwise prohibited by these regulations where specific enforcement would result in unnecessary hardship.

Violation means the failure of a structure or other development to be fully compliant with these regulations. A structure or other development without the elevation, other certification, or other

evidence of compliance required in these regulations is presumed to be in violation until such time as that documentation is provided.

Watercourse means a lake, river, creek, stream, wash, channel or other topographic feature on or over which waters flow at least periodically. Watercourse includes specifically designated areas in which substantial flood damage may occur.

Water surface elevation means the height, in relation to the North American Vertical Datum of 1988 (NAVD 88) or National Geodetic Vertical Datum of 1929 (NGVD) (other datum where specified) of floods of various magnitudes and frequencies in the floodplains of riverine areas.

X zone means the area where the flood hazard is less than that in the SFHA. Shaded X zones shown on recent FIRMs (B zones on older FIRMs) designate areas subject to inundation by the flood with a 0.2 percent chance of being equaled or exceeded (the 500-year flood). Unshaded X zones (C zones on older FIRMs) designate areas where the annual exceedance probability of flooding is less than 0.2 percent.

Zone means a geographical area shown on a FHBM or FIRM that reflects the severity or type of flooding in the area.

Zone A (see definition for A zone)

Zone B, C, and X means areas identified in the community as areas of moderate or minimal hazard from the principal source of flood in the area. However, buildings in these zones could be flooded by severe, concentrated rainfall coupled with inadequate local drainage systems. Flood insurance is available in participating communities but is not required by regulation in these zones. (Zone X is used on new and revised maps in place of Zones B and C.)

Article 3. General Provisions.

Section A. Lands to Which These Regulations Apply.

These regulations shall apply to all SFHAs and known flood prone areas within the jurisdiction of the County.

Section B. Basis for Establishing Regulatory Flood Data.

These regulations' protection standard is the regulatory flood. The best available regulatory flood data is listed below. Whenever a party disagrees with the best available data, the party submitting the detailed engineering study needs to replace existing data with better data and submit it to the Indiana Department of Natural Resources for review and approval.

- (1) The regulatory flood elevation, floodway, and fringe limits for the studied SFHAs within the jurisdiction of the County shall be as delineated on the one-percent annual chance flood profiles in the Flood Insurance Study of White County, Indiana and Incorporated Areas dated January 8, 2014 and the corresponding Flood Insurance Rate Map prepared by the Federal Emergency Management Agency and dated January 8, 2014 as well as any future updates, amendments, or revisions, prepared by the Federal Emergency Management Agency with the most recent date.
- (2) The regulatory flood elevation, floodway, and fringe limits for each of the SFHAs within the jurisdiction of the County, delineated as an "A Zone" on the White County, Indiana and Incorporated Areas Flood Insurance Rate Map prepared by the Federal Emergency

Management Agency and dated January 8, 2014 as well as any future updates, amendments, or revisions, prepared by the Federal Emergency Management Agency with the most recent date shall be according to the best data available as provided by the Indiana Department of Natural Resources; provided the upstream drainage area from the subject site is greater than one square mile.

- (3) In the absence of a published FEMA map, or absence of identification on a FEMA map, the regulatory flood elevation, floodway, and fringe limits of any watercourse in the community's known flood prone areas shall be according to the best data available as provided by the Indiana Department of Natural Resources; provided the upstream drainage area from the subject site is greater than one square mile.

Section C. Establishment of Floodplain Development Permit.

A Floodplain Development Permit shall be required in conformance with the provisions of these regulations prior to the commencement of any development activities in areas of special flood hazard.

Section D. Compliance.

No structure shall hereafter be located, extended, converted or structurally altered within the SFHA without full compliance with the terms of these regulations and other applicable regulations. No land or stream within the SFHA shall hereafter be altered without full compliance with the terms of these regulations and other applicable regulations.

Section E. Abrogation and Greater Restrictions.

These regulations are not intended to repeal, abrogate, or impair any existing easements, covenants, or deed restrictions. However, where these regulations and another conflict or overlap, whichever imposes the more stringent restrictions shall prevail.

Section F. Discrepancy between Mapped Floodplain and Actual Ground Elevations.

- (1) In cases where there is a discrepancy between the mapped floodplain (SFHA) on the FIRM and the actual ground elevations, the elevation provided on the profiles shall govern.
- (2) If the elevation of the site in question is below the base flood elevation, that site shall be included in the SFHA and regulated accordingly.
- (3) If the elevation (natural grade) of the site in question is above the base flood elevation, that site shall be considered outside the SFHA and the floodplain regulations will not be applied. The property owner should be advised to apply for a LOMA.

Section G. Interpretation.

In the interpretation and application of these regulations all provisions shall be:

- (1) Considered as minimum requirements.
- (2) Liberally construed in favor of the governing body.
- (3) Deemed neither to limit nor repeal any other powers granted under state statutes.

Section H. Warning and Disclaimer of Liability.

The degree of flood protection required by these regulations is considered reasonable for regulatory purposes and is based on available information derived from engineering and scientific methods of study. Larger floods can and will occur on rare occasions. Therefore, these regulations do not create any liability on the part of the County, the Indiana Department of Natural Resources, or the State of Indiana, for any flood damage that results from reliance on these regulations or any administrative decision made lawfully thereunder.

Section I. Penalties for Violation.

Failure to obtain a Floodplain Development Permit in the SFHA or failure to comply with the requirements of a Floodplain Development Permit or conditions of a variance shall be deemed to be a violation of these regulations. All violations shall be considered a common nuisance and be treated as such in accordance with the provisions of the Zoning Code for White County. All violations shall be punishable by a fine not exceeding three hundred dollars (\$300.00).

- (1) A separate offense shall be deemed to occur for each day the violation continues to exist.
- (2) The Floodplain Administrator shall inform the owner that any such violation is considered a willful act to increase flood damages and therefore may cause coverage by a Standard Flood Insurance Policy to be suspended.

- (3) Nothing herein shall prevent the County from taking such other lawful action to prevent or remedy any violations. All costs connected therewith shall accrue to the person or persons responsible.

Section J. Increased Cost of Compliance (ICC).

In order for buildings to qualify for a claim payment under ICC coverage as a “repetitive loss structure”, the National Reform Act of 1994 requires that the building be covered by a contract for flood insurance and incur flood-related damages on two occasions during a 10-year period ending on the date of the event for which the second claim is made, in which the cost of repairing the flood damage, on the average, equaled or exceeded 25 percent of the market value of the building at the time of each such flood event.

Article 4. Administration.

Section A. Designation of Administrator.

The White County Area Plan Commission hereby appoints the Building Commissioner to administer and implement the provisions of these regulations and is herein referred to as the Floodplain Administrator.

Section B. Permit Procedures.

Application for a Floodplain Development Permit shall be made to the Floodplain Administrator on forms furnished by him or her prior to any development activities, and may include, but not be limited to, the following: plans in duplicate drawn to scale showing the nature, location, dimensions, and elevations of the area in question; existing or proposed structures, earthen fill, storage of materials or equipment, drainage facilities, and the location of the foregoing. Specifically the following information is required:

- (1) Application stage.
 - a). A description of the proposed development.
 - b). Location of the proposed development sufficient to accurately locate property and structure in relation to existing roads and streams.
 - c). A legal description of the property site.
 - d). A site development plan showing existing and proposed development locations and existing and proposed land grades.
 - e). Elevation of the top of the lowest floor (including basement) of all proposed buildings. Elevation should be in NAVD 88 or NGVD.
 - f). Elevation (in NAVD 88 or NGVD) to which any non-residential structure will be floodproofed.
 - g). Description of the extent to which any watercourse will be altered or relocated as a result of proposed development.

- (2) Construction stage.

Upon placement of the lowest floor; or floodproofing, it shall be the duty of the permit holder to submit to the Floodplain Administrator a certification of the NAVD 88 or NGVD elevation of the lowest floor or floodproofed elevation, as built. Said certification shall be prepared by or under

the direct supervision of a registered land surveyor or professional engineer and certified by the same. When floodproofing is utilized for a particular structure said certification shall be prepared by or under the direct supervision of a professional engineer or architect and certified by same. Any work undertaken prior to submission of the certification shall be at the permit holders' risk. (The Floodplain Administrator shall review the lowest floor and floodproofing elevation survey data submitted.) The permit holder shall correct deficiencies detected by such review before any further work is allowed to proceed. Failure to submit the survey or failure to make said corrections required hereby shall be cause to issue a stop-work order for the project.

Section C. Duties and Responsibilities of the Floodplain Administrator.

The Floodplain Administrator and/or designated staff is hereby authorized and directed to enforce the provisions of these regulations. The administrator is further authorized to render interpretations of these regulations, which are consistent with its spirit and purpose.

Duties and Responsibilities of the Floodplain Administrator shall include, but not be limited to:

- (1) Review all floodplain development permits to assure that the permit requirements of these regulations have been satisfied.
- (2) Inspect and inventory damaged structures in the SFHA and complete substantial damage determinations.
- (3) Ensure that construction authorization has been granted by the Indiana Department of Natural Resources for all development projects subject to Article 5, Section E and G (1) of these regulations, and maintain a record of such authorization (either copy of actual permit or floodplain analysis/regulatory assessment).
- (4) Ensure that all necessary federal or state permits have been received prior to issuance of the local floodplain development permit. Copies of such permits are to be maintained on file with the floodplain development permit.
- (5) Notify adjacent communities and the State Floodplain Coordinator prior to any alteration or relocation of a watercourse, and submit copies of such notifications to FEMA.
- (6) Maintain for public inspection and furnish upon request local permit documents, damaged structure inventories, substantial damage determinations, regulatory flood data, SFHA maps, Letters of Map Amendment (LOMA), Letters of Map Revision (LOMR), copies of DNR permits and floodplain analysis and regulatory assessments (letters of recommendation), federal permit documents, and "as-built" elevation and floodproofing data for all buildings constructed subject to these regulations.
- (7) Utilize and enforce all Letters of Map Revision (LOMR) or Physical Map Revisions (PMR) issued by FEMA for the currently effective SFHA maps of the community.
- (8) Assure that maintenance is provided within the altered or relocated portion of said watercourse so that the flood-carrying capacity is not diminished.
- (9) Verify and record the actual elevation of the lowest floor (including basement) of all new or substantially improved structures, in accordance with Article 4 Section B.
- (10) Verify and record the actual elevation to which any new or substantially improved structures have been floodproofed in accordance with Article 4, Section B.

- (11) Review certified plans and specifications for compliance.
- (12) Stop Work Orders
 - a). Upon notice from the floodplain administrator, work on any building, structure or premises that is being done contrary to the provisions of these regulations shall immediately cease.
 - b). Such notice shall be in writing and shall be given to the owner of the property, or to his agent, or to the person doing the work, and shall state the conditions under which work may be resumed.
- (13) Revocation of Permits
 - a). The floodplain administrator may revoke a permit or approval, issued under the provisions of the ordinance, in cases where there has been any false statement or misrepresentation as to the material fact in the application or plans on which the permit or approval was based.
 - b). The floodplain administrator may revoke a permit upon determination by the floodplain administrator that the construction, erection, alteration, repair, moving, demolition, installation, or replacement of the structure for which the permit was issued is in violation of, or not in conformity with, the provisions of these regulations.
- (14) Inspect sites for compliance. For all new and/or substantially improved buildings constructed in the SFHA, inspect before, during and after construction. Authorized County officials shall have the right to enter and inspect properties located in the SFHA.

Article 5. Provisions for Flood Hazard Reduction.

Section A. General Standards.

In all SFHAs and known flood prone areas the following provisions are required:

- (1) New construction and substantial improvements shall be anchored to prevent flotation, collapse or lateral movement of the structure.
- (2) Manufactured homes shall be anchored to prevent flotation, collapse, or lateral movement. Methods of anchoring may include, but are not limited to, use of over-the-top or frame ties to ground anchors. This standard shall be in addition to and consistent with applicable state requirements for resisting wind forces.
- (3) New construction and substantial improvements shall be constructed with materials and utility equipment resistant to flood damage below the FPG.
- (4) New construction and substantial improvements shall be constructed by methods and practices that minimize flood damage.
- (5) Electrical, heating, ventilation, plumbing, air conditioning equipment, utility meters, and other service facilities shall be located at/above the FPG or designed so as to prevent water from entering or accumulating within the components below the FPG. Water and sewer pipes, electrical and telephone lines, submersible pumps, and other waterproofed service facilities may be located below the FPG.

- (6) New and replacement water supply systems shall be designed to minimize or eliminate infiltration of flood waters into the system.
- (7) New and replacement sanitary sewage systems shall be designed to minimize or eliminate infiltration of flood waters into the system.
- (8) On-site waste disposal systems shall be located and constructed to avoid impairment to them or contamination from them during flooding.
- (9) Any alteration, repair, reconstruction or improvements to a structure that is in compliance with the provisions of these regulations shall meet the requirements of "new construction" as contained in these regulations.
- (10) Any alteration, repair, reconstruction or improvement to a structure that is not in compliance with the provisions of these regulations, shall be undertaken only if said non-conformity is not further extended, or replaced.
- (11) Whenever any portion of the SFHA is authorized for use, the volume of space which will be occupied by the authorized fill or structure below the BFE shall be compensated for and balanced by an equivalent volume of excavation taken below the BFE. The excavation volume shall be at least equal to the volume of storage lost (replacement ratio of 1 to 1) due to the fill or structure.
 - a). The excavation shall take place in the floodplain and in the same property in which the authorized fill or structure is located.
 - b). Under certain circumstances, the excavation may be allowed to take place outside of but adjacent to the floodplain provided that the excavated volume will be below the regulatory flood elevation, will be in the same property in which the authorized fill or structure is located, will be accessible to the regulatory flood water, will not be subject to ponding when not inundated by flood water, and that it shall not be refilled.
 - c). The excavation shall provide for true storage of floodwater but shall not be subject to ponding when not inundated by flood water.
 - d). The fill or structure shall not obstruct a drainage way leading to the floodplain.
 - e). The grading around the excavation shall be such that the excavated area is accessible to the regulatory flood water.
 - f). The fill or structure shall be of a material deemed stable enough to remain firm and in place during periods of flooding and shall include provisions to protect adjacent property owners against any increased runoff or drainage resulting from its placement.
 - g). Plans depicting the areas to be excavated and filled shall be submitted prior to the actual start of construction or any site work; once site work is complete, but before the actual start of construction, the applicant shall provide to the Floodplain Administrator a certified survey of the excavation and fill sites demonstrating the fill and excavation comply with this article.

Section B. Specific Standards.

In all SFHAs, the following provisions are required:

- (1) In addition to the requirements of Article 5, Section A, all structures to be located in the SFHA shall be protected from flood damage below the FPG. This building protection requirement applies to the following situations:
 - a). Construction or placement of any new structure having a floor area greater than 400 square feet.
 - b). Addition or improvement made to any existing structure:
 - (i) where the cost of the addition or improvement equals or exceeds 50% of the value of the existing structure (excluding the value of the land).
 - (ii) with a previous addition or improvement constructed since the community's first floodplain ordinance.
 - c). Reconstruction or repairs made to a damaged structure where the costs of restoring the structure to its before damaged condition equals or exceeds 50% of the market value of the structure (excluding the value of the land) before damage occurred.
 - d). Installing a travel trailer or recreational vehicle on a site for more than 180 days.
 - e). Installing a manufactured home on a new site or a new manufactured home on an existing site. These regulations do not apply to returning the existing manufactured home to the same site it lawfully occupied before it was removed to avoid flood damage.
 - f). Reconstruction or repairs made to a repetitive loss structure.
- (2) **Residential Construction.** New construction or substantial improvement of any residential structure (or manufactured home) shall have the lowest floor, including basement, at or above the FPG (two feet above the base flood elevation). Should solid foundation perimeter walls be used to elevate a structure, openings sufficient to facilitate the unimpeded movements of floodwaters shall be provided in accordance with the standards of Article 5, Section B (4).
- (3) **Non-Residential Construction.** New construction or substantial improvement of any commercial, industrial, or non-residential structure (or manufactured home) shall either have the lowest floor, including basement, elevated to or above the FPG (two feet above the base flood elevation) or be floodproofed to or above the FPG. Should solid foundation perimeter walls be used to elevate a structure, openings sufficient to facilitate the unimpeded movements of floodwaters shall be provided in accordance with the standards of Article 5, Section B (4). Structures located in all "A Zones" may be floodproofed in lieu of being elevated if done in accordance with the following:
 - a). A Registered Professional Engineer or Architect shall certify that the structure has been designed so that below the FPG, the structure and attendant utility facilities are watertight and capable of resisting the effects of the regulatory flood. The structure design shall take into account flood velocities, duration, rate of rise, hydrostatic pressures, and impacts from debris or ice. Such certification shall be provided to the official as set forth in Article 4, Section C (10).
 - b). Floodproofing measures shall be operable without human intervention and without an outside source of electricity.
- (4) **Elevated Structures.** New construction or substantial improvements of elevated structures shall have the lowest floor at or above the FPG.

Elevated structures with fully enclosed areas formed by foundation and other exterior walls below the flood protection grade shall be designed to preclude finished living space and designed to allow for the entry and exit of floodwaters to automatically equalize hydrostatic flood forces on exterior walls. Designs must meet the following minimum criteria:

- a). Provide a minimum of two openings located in a minimum of two exterior walls (having a total net area of not less than one square inch for every one square foot of enclosed area).
 - b). The bottom of all openings shall be no more than one foot above the exterior grade or the interior grade immediately beneath each opening, whichever is higher.
 - c). Openings may be equipped with screens, louvers, valves or other coverings or devices provided they permit the automatic flow of floodwaters in both directions.
 - e). Access to the enclosed area shall be the minimum necessary to allow for parking for vehicles (garage door) or limited storage of maintenance equipment used in connection with the premises (standard exterior door) or entry to the living area (stairway or elevator).
 - f). The interior portion of such enclosed area shall not be partitioned or finished into separate rooms.
 - g). The interior grade of such enclosed area shall be at an elevation at or higher than the exterior grade.
- (5) **Structures Constructed on Fill.** A residential or nonresidential structure may be constructed on a permanent land fill in accordance with the following:
- a). The fill shall be placed in layers no greater than 1 foot deep before compacting to 95% of the maximum density obtainable with either the Standard or Modified Proctor Test method.
 - b). The fill should extend at least ten feet beyond the foundation of the structure before sloping below the FPG.
 - c). The fill shall be protected against erosion and scour during flooding by vegetative cover, riprap, or bulkheading. If vegetative cover is used, the slopes shall be no steeper than 3 horizontal to 1 vertical.
 - d). The fill shall not adversely affect the flow of surface drainage from or onto neighboring properties.
 - e). The top of the lowest floor including basements shall be at or above the FPG.
- (6) **Standards for Manufactured Homes and Recreational Vehicles.** Manufactured homes and recreational vehicles to be installed or substantially improved on a site for more than 180 days must meet one of the following requirements:
- a). The manufactured home shall be elevated on a permanent foundation such that the lowest floor shall be at or above the FPG and securely anchored to an adequately anchored foundation system to resist flotation, collapse, and lateral movement. This requirement applies to all manufactured homes to be placed on a site;
 - (i) outside a manufactured home park or subdivision;

- (ii) in a new manufactured home park or subdivision;
 - (iii) in an expansion to an existing manufactured home park or subdivision; or
 - (iv) in an existing manufactured home park or subdivision on which a manufactured home has incurred "substantial damage" as a result of a flood.
- b). The manufactured home shall be elevated so that the lowest floor of the manufactured home chassis is supported by reinforced piers or other foundation elevations that are no less than 36 inches in height above grade and be securely anchored to an adequately anchored foundation system to resist flotation, collapse, and lateral movement. This requirement applies to all manufactured homes to be placed on a site in an existing manufactured home park or subdivision that has not been substantially damaged by a flood.
- c). Manufactured homes with fully enclosed areas formed by foundation and other exterior walls below the flood protection grade shall be designed to preclude finished living space and designed to allow for the entry and exit of floodwaters to automatically equalize hydrostatic flood forces on exterior walls as required for elevated structures in Article 5, Section B. 4.
- d). Flexible skirting and rigid skirting not attached to the frame or foundation of a manufactured home are not required to have openings.
- e). Recreational vehicles placed on a site shall either:
- (i) be on site for less than 180 days; and,
 - (ii) be fully licensed and ready for highway use (defined as being on its wheels or jacking system, is attached to the site only by quick disconnect type utilities and security devices, and has no permanently attached additions); or
 - (iii) meet the requirements for "manufactured homes" as stated earlier in this section.

Section C. Standards for Subdivision Proposals.

- (1) All subdivision proposals shall be consistent with the need to minimize flood damage.
- (2) All subdivision proposals shall have public utilities and facilities such as sewer, gas, electrical, and water systems located and constructed to minimize flood damage.
- (3) All subdivision proposals shall have adequate drainage provided to reduce exposure to flood hazards.
- (4) Base flood elevation data shall be provided for subdivision proposals and other proposed development (including manufactured home parks and subdivisions), which is greater than the lesser of fifty lots or five acres.

Section D. Critical Facility.

Construction of new critical facilities shall be, to the extent possible, located outside the limits of the SFHA. Construction of new critical facilities shall be permissible within the SFHA if no feasible alternative site is available. Critical facilities constructed within the SFHA shall have the lowest floor elevated to or above the FPG at the site. Floodproofing and sealing measures must be taken to ensure that toxic

substances will not be displaced by or released into floodwaters. Access routes elevated to or above the FPG shall be provided to all critical facilities to the extent possible.

Section E. Standards for Identified Floodways.

Located within SFHAs, established in Article 3, Section B, are areas designated as floodways. The floodway is an extremely hazardous area due to the velocity of floodwaters, which carry debris, potential projectiles, and has erosion potential. If the site is in an identified floodway, the Floodplain Administrator shall require the applicant to forward the application, along with all pertinent plans and specifications, to the Indiana Department of Natural Resources and apply for a permit for construction in a floodway. Under the provisions of IC 14-28-1 a permit for construction in a floodway from the Indiana Department of Natural Resources is required prior to the issuance of a local building permit for any excavation, deposit, construction, or obstruction activity located in the floodway. This includes land preparation activities such as filling, grading, clearing and paving etc. undertaken before the actual start of construction of the structure. However, it does exclude non-substantial additions/improvements to existing (lawful) residences in a non-boundary river floodway. (IC 14-28-1-26 allows construction of non-substantial additions/ improvements to residences in a non-boundary river floodway without obtaining a permit for construction in the floodway from the Indiana Department of Natural Resources. Please note that if fill is needed to elevate an addition above the existing grade, prior approval (construction in a floodway permit) for the fill is required from the Indiana Department of Natural Resources.)

No action shall be taken by the Floodplain Administrator until a permit (when applicable) has been issued by the Indiana Department of Natural Resources granting approval for construction in the floodway. Once a permit for construction in a floodway has been issued by the Indiana Department of Natural Resources, the Floodplain Administrator may issue the local Floodplain Development Permit, provided the provisions contained in Article 5 of these regulations have been met. The Floodplain Development Permit cannot be less restrictive than the permit for construction in a floodway issued by the Indiana Department of Natural Resources. However, a community's more restrictive regulations (if any) shall take precedence.

No development shall be allowed which acting alone or in combination with existing or future development, will increase the regulatory flood more than 0.14 of one foot.

For all projects involving channel modifications or fill (including levees) the **County** shall submit the data and request that the Federal Emergency Management Agency revise the regulatory flood data.

Section F. Standards for Identified Fringe.

If the site is located in an identified fringe, then the Floodplain Administrator may issue the local Floodplain Development Permit provided the provisions contained in Article 5 of these regulations have been met. The key provision is that the top of the lowest floor of any new or substantially improved structure shall be at or above the FPG.

Section G. Standards for SFHAs Without Established Base Flood Elevation and/or Floodways/Fringes.

- (1) Drainage area upstream of the site is greater than one square mile:

If the site is in an identified floodplain where the limits of the floodway and fringe have not yet been determined, and the drainage area upstream of the site is greater than one square mile, the Floodplain Administrator shall require the applicant to forward the application, along with all pertinent plans and specifications, to the Indiana Department of Natural Resources for review and comment.

No action shall be taken by the Floodplain Administrator until either a permit for construction in a floodway or a floodplain analysis/regulatory assessment citing the one-percent annual chance flood elevation and the recommended Flood Protection Grade has been received from the Indiana Department of Natural Resources.

Once the Floodplain Administrator has received the proper permit for construction in a floodway or floodplain analysis/regulatory assessment approving the proposed development, a Floodplain Development Permit may be issued provided the conditions of the Floodplain Development Permit are not less restrictive than the conditions received from the Indiana Department of Natural Resources and the provisions contained in Article 5 of these regulations have been met.

- (2) Drainage area upstream of the site is less than one square mile:

If the site is in an identified floodplain where the limits of the floodway and fringe have not yet been determined and the drainage area upstream of the site is less than one square mile, the Floodplain Administrator shall require the applicant to provide an engineering analysis showing the limits of the floodplain and one-percent annual chance flood elevation for the site.

Upon receipt, the Floodplain Administrator may issue the local Floodplain Development Permit, provided the provisions contained in Article 5 of these regulations have been met.

- (3) The total cumulative effect of the proposed development, when combined with all other existing and anticipated development, will not increase the regulatory flood more than 0.14 of one foot and will not increase flood damages or potential flood damages.

Section H. Standards for Flood Prone Areas.

All development in known flood prone areas not identified on FEMA maps, or where no FEMA published map is available, shall meet applicable standards as required per Article 5.

Article 6. Variance Procedures.

Section A. Designation of Variance and Appeals Board.

The White County Board of Zoning Appeals shall hear and decide appeals and requests for variances from requirements of these regulations.

Section B. Duties of Variance and Appeals Board.

The board shall hear and decide appeals when it is alleged an error in any requirement, decision, or determination is made by the Floodplain Administrator in the enforcement or administration of these regulations. Any person aggrieved by the decision of the board may appeal such decision to the Judicial review as provided for in Chapter 13 of the White County Indiana Zoning Control Ordinance.

Section C. Variance Procedures.

In passing upon such applications, the Board of Zoning Appeals shall consider all technical evaluations, all relevant factors, all standards specified in other sections of these regulations, and;

- (1) The danger of life and property due to flooding or erosion damage.
- (2) The susceptibility of the proposed facility and its contents to flood damage and the effect of such damage on the individual owner.

- (3) The importance of the services provided by the proposed facility to the community.
- (4) The necessity to the facility of a waterfront location, where applicable.
- (5) The availability of alternative locations for the proposed use which are not subject to flooding or erosion damage.
- (6) The compatibility of the proposed use with existing and anticipated development,
- (7) The relationship of the proposed use to the comprehensive plan and floodplain management program for that area.
- (8) The safety of access to the property in times of flood for ordinary and emergency vehicles.
- (9) The expected height, velocity, duration, rate of rise, and sediment of transport of the floodwaters at the site.
- (10) The costs of providing governmental services during and after flood conditions, including maintenance and repair of public utilities and facilities such as sewer, gas, electrical, and water systems, and streets and bridges.

Section D. Conditions for Variances.

- (1) Variances shall only be issued when there is:
 - a). A showing of good and sufficient cause.
 - b). A determination that failure to grant the variance would result in exceptional hardship.
 - c). A determination that the granting of a variance will not result in increased flood heights, additional threats to public safety, extraordinary public expense, create nuisances, cause fraud or victimization of the public, or conflict with existing laws or ordinances.
- (2) No variance for a residential use within a floodway subject to Article 5, Section E or Section G (1) of these regulations may be granted.
- (3) Any variance granted in a floodway subject to Article 5, Section E or Section G (1) of these regulations will require a permit from the Indiana Department of Natural Resources.
- (4) Variances to the Provisions for Flood Hazard Reduction of Article 5, Section B, may be granted only when a new structure is to be located on a lot of one-half acre or less in size, contiguous to and surrounded by lots with existing structures constructed below the flood protection grade.
- (5) Variances shall only be issued upon a determination that the variance is the minimum necessary, considering the flood hazard, to afford relief.
- (6) Variances may be granted for the reconstruction or restoration of any structure individually listed on the National Register of Historic Places or the Indiana State Register of Historic Sites and Structures.
- (7) Any applicant to whom a variance is granted shall be given written notice specifying the difference between the base flood elevation and the elevation to which the lowest floor is to be built and stating that the cost of the flood insurance will be commensurate with the increased risk resulting from the reduced lowest floor elevation (See Article 6, Section E).
- (8) The Area Plan Commission Staff shall maintain the records of variances and the Floodplain Administrator shall report any variances to the Federal Emergency Management Agency or the Indiana Department of Natural Resources upon request (See Article 6, Section E).

Section E. Variance Notification.

Any applicant to whom a variance is granted shall be given written notice over the signature of a community official that:

- (1) The issuance of a variance to construct a structure below the base flood elevation will result in increased premium rates for flood insurance up to amounts as high as \$25 for \$100 of insurance coverage; and;
- (2) Such construction below the base flood level increases risks to life and property.

The Area Plan Commission Staff will maintain a record of all variance actions, including justification for their issuance. The Floodplain Administrator will report such variances issued in the community's biennial report submission to the Federal Emergency Management Agency.

Section F. Historic Structure.

Variations may be issued for the repair or rehabilitation of “historic structures” upon a determination that the proposed repair or rehabilitation will not preclude the structure’s continued designation as an “historic structure” and the variance is the minimum to preserve the historic character and design of the structure.

Section G. Special Conditions.

Upon the consideration of the factors listed in Article 6, and the purposes of these regulations, the **White** County Board of Zoning Appeals may attach such conditions to the granting of variances as it deems necessary to further the purposes of these regulations.

Article 7. Severability.

If any section, clause, sentence, or phrase of these Regulations is held to be invalid or unconstitutional by any court of competent jurisdiction, then said holding shall in no way effect the validity of the remaining portions of these Regulations.

Article 8. Effective Date.

These regulations shall take effect upon its passage by the White County Commissioners.

Passed and enacted by the White County Commissioners, Indiana on the
[Click here and type day of month] day of**[Click here and type month]**, 2013.

[Click here and type name of governing body]
[Click here and type name of Community], Indiana

[Click here and type name of individual approving]

[Click here and type name of individual approving]

[Click here and type name of individual approving]

Attest: _____
[Click here and type name of individual attesting]