

NOTICE OF PUBLIC HEARING

Description of Proposed Docket:

The applicant _____ is seeking a:

- Zoning Map Change (Standard or Planned Unit Development)
- Minor Subdivision (Five Lots or less)
- Major Subdivision (Five Lots or more as a Traditional Design)
- Conservation Subdivision (Five Lots or more with an Open Space Design)
- Planned Unit Development (PUD)
- Development Review (Site Review for new Structure)
- Administrative Appeal

From the **Floyd County Plan Commission.**

Street Address (see enclosed map):
Description of Project:

This is a notice that a public hearing regarding the proposed docket item will be on _____ located in **Suite 104 at the Pineview Government Center, 2524 Corydon Pike New Albany, IN 47150.**

Please note that information about the proposed docket item can be found at the following:

Floyd County Building and Development Services

2524 Corydon Pike Suite 203

New Albany, IN 47150

Monday- Friday 8AM to 4PM

812.981.7611

Building@floydcounty.in.gov

Floyd County Government Website www.floydcounty.in.gov

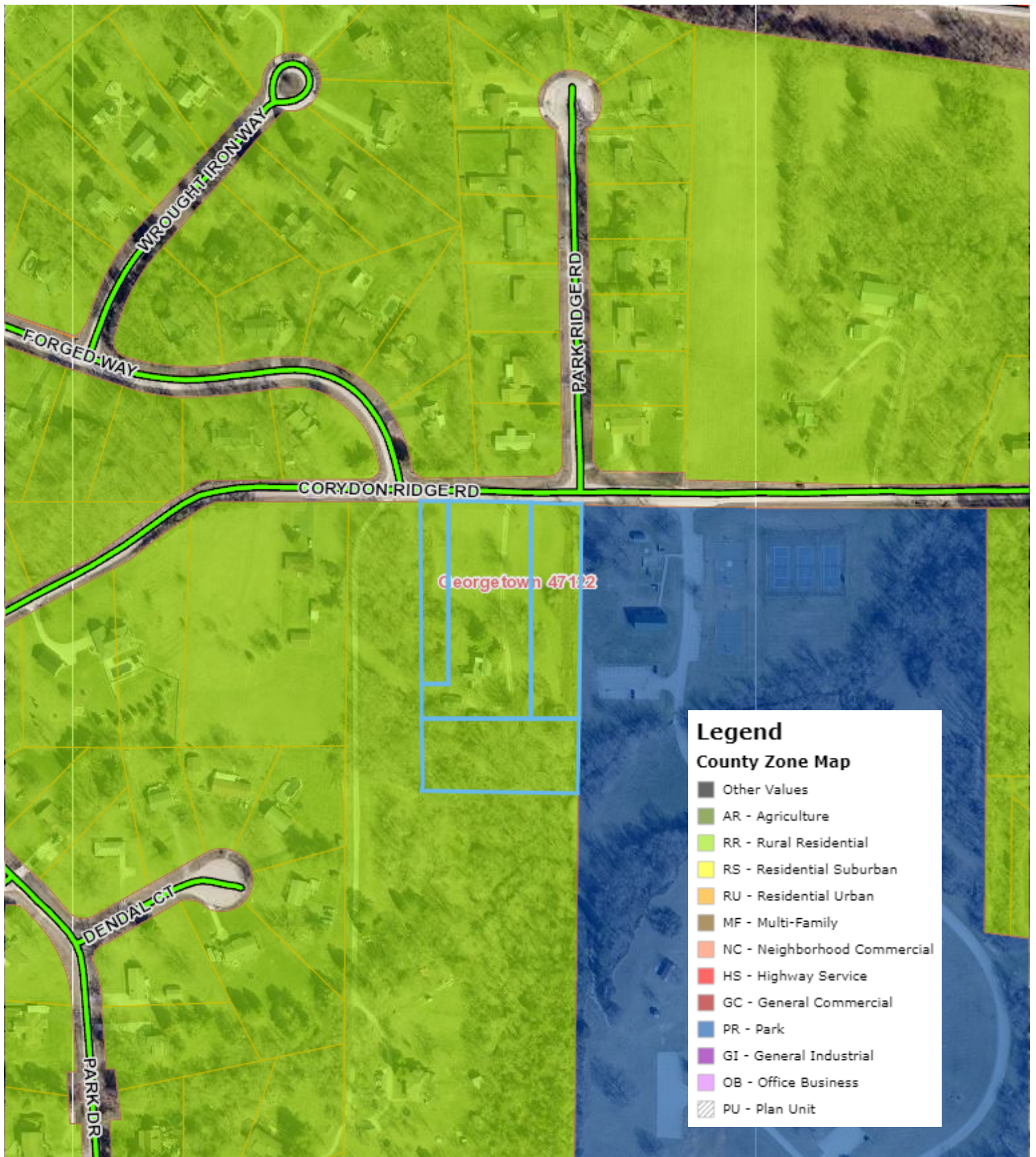

Floyd County Plan Commission Frequently Asked Questions

1. How can I find out more about this docket?

You can either visit the Floyd County Building and Development Services Office and review the file between the hours of 8AM to 4PM Monday through Friday or you can review the proposed application on-line at www.floydcounty.in.gov on the Plan Commission page.

2. How does this process work?

Depending on the docket, there are several different processes. The Plan Commission will take public comments on each proposal and values public comment in their decision-making process. The Plan Commission is required to follow state statute when considering each application. Below is a brief description of each application that may come before the commission. Please note the check marked application on the notification form to the corresponding process listed below:

- **Zoning** – The applicant is seeking to change the land use associated with the property in the proposed application. Per Indiana State statute, the Plan Commission holds a public hearing and determines a recommendation to the County Commissioners. The recommendation may be favorable, unfavorable or no recommendation. The recommendation is non-binding on the decision of the commissioners

The application is sent to the County Commissioners Office to place on their agenda following the Plan Commission hearing. The Commissioners have 90 days to make a decision on the application. They can approve, disapprove, or take no action. If no action is taken within 90 days, the recommendation of the Plan Commission then becomes binding.

- **Subdivision** – The applicant is seeking to subdivide the land. There are three types of subdivisions (Minor, Major and Conservation). The County has a set of rules regarding the subdivision of land. These rules include the placement and specifications of any new road, drainage, and sidewalks. It also has rules regarding utility and public safety services to the proposed application. The number of lots and their configuration are also part of the process. Additionally, studies of impacts on drainage, traffic, and the environment are reviewed if required.

If an applicant has demonstrated through its application that the County rules have been met, then the Plan Commission must approve the subdivision per Indiana State Statue. The Plan Commission does have the ability to place reasonable conditions on the applicant regarding their proposal.

- **Development Review** – The applicant is seeking approval to place a building on a site that must meet County standards. The County sets standards as it relates to building size, façade, sidewalks, parking, lighting, drainage, signage and landscaping. If an applicant has demonstrated through its application that the County rules have been met, then the Plan Commission must approve the plan per Indiana State Statue. The Plan Commission does have the ability to place reasonable conditions on the applicant regarding their proposal.



April 5, 2024

Floyd County Department of
Building & Development Services
c/o Plan Commission
2524 Corydon Pike Suite 202
New Albany, IN 47150

*** Sent via email to: Building@floydcounty.in.gov ***

Re: Petition for rezoning of 6527 Corydon Ridge Rd.

Dear Plan Commission:

I write this letter as part of our application to seek a rezoning of 6527 Corydon Ridge Road (the "Property") from Residential Rural to Residential Urban. The Property is approximately 5.06 +/- acres and is adjacent to Garry E. Caven Park. The Property also has access to sanitary sewers, which is somewhat rare for property in Floyd County.

If successful with the rezoning process, we intend on building a luxury garden-style patio home community. There will be no vinyl siding on the homes. The homes will be a mixture of both brick and hardie board, with black framed windows. In addition, they will have open floor plans with at least 9 feet high ceilings and include high end finishes.

This small pocket neighborhood will have no more than 18 lots and will help provide additional housing options to Floyd County. The zoning ordinance states that the plan commission should try and maintain no more than 6 homes per acres in a Residential Urban zoning designation, which would technically allow for up to 30 but we have no objection to placing a condition on the development to 18 lots if approved. From a density standpoint this development falls more in line with the zoning designation Residential Suburban (i.e. 3 homes per acres), but smaller lots are preferred in these types of developments to limit the amount of maintenance, which is why we are seeking a Residential Urban zoning.

We believe this proposed development will be a great addition to Floyd County and we look forward to presenting our thoughts to you at the meeting.

Sincerely,

Jacob C. Elder

Jacob C. Elder



Floyd County
Department of Building & Development Services
2524 Corydon Pike Suite 202
New Albany, IN 47150
Phone: (812) 981-7611
Fax: (812) 948-4744
Building@floydcounty.in.gov

Zoning Map Amendment Application

Please Note:

This Application is a document of public record. Any information disclosed on this application is available for review by the public. Incomplete applications will not be accepted. A pre-submission meeting with Building and Development Staff is strongly encouraged. Please contact the office at 812-981-7611 to schedule a meeting.

1. General Information:

Applicant:	The Elder Co., LLC
Applicant Address:	501 E. Pearl St. New Albany, IN
Applicant Phone:	502-938-8115
Applicant Email:	jelder@theelderco.com

Applicant's Interest in Property:

Owner Option Holder Purchase Agreement Legal Representative Other

Owner(s) of Property: (complete this section if *owner* is different than applicant)

Owner Name:	
Owner Address:	
Owner Phone:	
Owner Email:	

Applicant's Representative:

Representative Name:	Jason Copperwaite
Representative Address:	301 E. Chestnut Corydon, IN 47112
Representative Phone:	(812) 738-4124
Representative Email:	jcopperwaite@ppa-eng.com

2. Site Information:

Parcel ID Number:	22-02-00-200-124.000-002
Total Acreage:	5.06 +/-
Address of Property/Location:	6527 Corydon Ridge Rd.
Current Use of Property:	Single Family Home
Current Zoning District:	Rural Residential

3. Zoning Map Amendment Request:

Detail the zoning map amendment request:

We are requesting a zoning map amendment to allow for a small pocket neighborhood which will be a garden-style patio home community.

Requested Zoning District: Residential Urban

4. Zoning Map Amendment Justification:

Indiana Code and the Floyd County Zoning Ordinance establish specific criteria to which both the Plan Commission and County Commissioners must "pay reasonable regard" when considering a zoning map amendment request. Explain how this request addresses each criterion.

1. The rezoning of the subject property is consistent with the Floyd County Comprehensive Plan and any other applicable, adopted planning studies or reports:

The proposed rezoning and garden-style patio home development is consistent with the Comprehensive Plan and Purdue Housing Report. The development is Smart Growth as defined by the Plan. "Smart Growth is a proposed development pattern that makes efficient use of...infrastructure, promotes...housing options...serves a significant portion of the future population growth, protects the...character of the County through compatible, high quality, and environmentally sensitive development practices." While open to people of all ages, this development will allow people to "age in place."

2. The rezoning of the subject property is consistent with the current conditions and the character of current structures and uses in the area:

The rezoning and future development would be consistent with the surrounding conditions and character of the homes. There are (4) neighborhoods within a .25mile radius of this property with an almost identical pocket neighborhood directly across the street.

3. The rezoning of the subject property is necessary for the most desirable use of the land:

The most desirable use of this land is a small pocket neighborhood development. Due to the lack of sanitary sewers, Floyd County does not have many opportunities for developments like this. This property borders the second largest park in the County and has access to sewers. A slight increase in density will allow for much needed additional housing options for the community.

4. The rezoning of the subject property will not be injurious to the value of other properties in the area:

This development will not be injurious to the value of the other properties in the area. The average home price in the .25 radius is approximately \$300,000. The average price for a home in this development will be approximately \$450,000 - \$550,000.

5. The rezoning of the subject property will support responsible growth and development:

The rezoning will support responsible growth and development as set forth in the Comprehensive Plan. While we are requesting a rezone to Residential Urban, our density request is more in line with Residential Suburban (i.e. a recommendation of 3.0 homes per acres as opposed to 6.0).

5. Required Documents:

- \$500.00 Filing Fee
- Deed for subject property
- Affidavit of Ownership (if applicable)
- A conceptual site plan drawn to scale showing all existing and any proposed structures, setbacks, easements, rights-of way, floodplains, and any other feature relevant to the petition.
- A vicinity map showing the use and zoning of all properties within 1,000 feet of the property subject to the re-zoning request.
- A letter of intent to the Plan Commission stating the reasons for the Zoning Map Amendment, including a detailed description of any proposed development for which the re-zoning is sought. The letter should include any written commitments being made by the petitioner.
- For proposals using septic systems, a letter from the Floyd County Health Department shall be provided verifying that any proposed development makes appropriate use of the septic system.
- For proposals using sanitary sewer systems, a letter from the service provider shall be included verifying that any proposed new development will be served.

6. Signature:

The undersigned states that the above information is true and correct.

Name: Jacob C. Ekker

Signature: [Handwritten Signature]

Date: 4/16/24

SUBSCRIBED AND SWORN BEFORE ME

THIS 16 DAY OF Apr, 2024.

Laura Biros Casey

NOTARY PUBLIC COUNTY OF Floyd

MY COMMISSION EXPIRES 6-11-2028



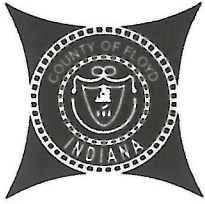

Floyd County Plan Commission
Floyd County Board of Zoning Appeals

AFFIDAVIT OF OWNERSHIP

If the owner(s) of the subject property are giving authorization for someone else to apply for this request, this attached attachment is to be completed and submitted at the time of the application.

I (We), Marilu Linderman, do hereby certify that I am (we are)
(Owners of subject property)

the owner(s) of the property legally described as 22-02-00-200-124.000-002,
(Parcel ID Number)

And hereby certify that I (we) have given authorization to The Elder Co, LLC,
(Applicant/Petitioner/Representative)

To apply for the included application on this subject property.

Name of Owner(s):	Parcel I.D. No:	Signature:	Date:
Marilu Linderman	0020610068	DocuSigned by: <u>Marilu Linderman</u> FFD8AD2F43544A2...	4/9/2024 3:10 EDT
		<u>Marilu Linderman</u>	4/10/2024

STATE OF IN)
) SS:
COUNTY OF FLOYD)

Subscribed and sworn to before me, a Notary Public within and for said County and State, this 10th day of April, 2024.

MY COMMISSION EXPIRES:
05/02/2031

MY COUNTY OF RESIDENCE:
Floyd

Samuel Cain
Notary Public

Samuel Cain
Printed Signature

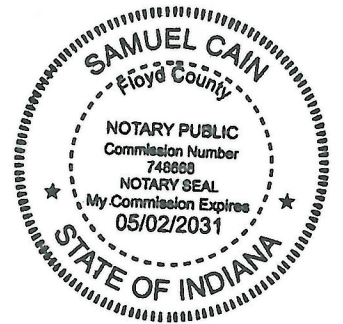

FLOYD COUNTY
ASSESSOR

Duly Entered For Taxation
Subject To Final Acceptance
For Transfer

E-RECORDED
202208948
FLOYD CO. IN RECORDER
LOIS ENDRIS
07/27/2022 08:01 AM
202208948 Pages: 4
Transaction # 4062515

Jul/26/2022

Send tax bill to:

Marilu Linderman
6527 Corydon Ridge Road
Georgetown, IN 47122

Parcel No. 22-02-00-200-124.000-002

Tax ID No. 002-06100-68

Jul 26 2022 - TDB

Jaqueline Weening
AUDITOR FLOYD CO. IND.

QUITCLAIM DEED

THIS INDENTURE WITNESSETH that Marilu Linderman and Chester D. Linderman (a/k/a Chester Linderman), wife and husband, Grantors, for and in consideration of the sum of One Dollar (\$1.00) and other good and valuable consideration, receipt of which is hereby acknowledged,

CONVEY and QUITCLAIM

Unto Marilu Linderman, in fee simple, all of the Grantors' rights, title and interest in and to the real estate in Floyd County, Indiana, commonly referred to as 6527 Corydon Ridge Rd., and more particularly described as follows:

See "Exhibit A".

Subject to any and all easements and/or restrictions of public record, which may apply to the above-described real estate.

No title exam has been performed prior to preparing this deed.

IN WITNESS WHEREOF, the Grantors have executed this deed on this July 18, 2022.

Marilu Linderman
Marilu Linderman, Grantor

Marilu Linderman, POA
Chester D. Linderman (a/k/a Chester Linderman), Grantor, by Marilu Linderman, pursuant to General Durable Power of Attorney dated September 7, 2021 and recorded as Instr. No. 202208911 in the Office of the Recorder of Floyd County, Indiana

STATE OF INDIANA)
)
COUNTY OF FLOYD) SS.

Before me, a Notary Public in and for the State and County aforesaid, personally appeared **Marilyn Linderman**, Grantor, and as attorney-in-fact for **Chester D. Linderman (a/k/a Chester Linderman)**, Grantor, and acknowledged the execution of the foregoing deed.

WITNESS my hand and Notarial Seal this July 18, 2022.

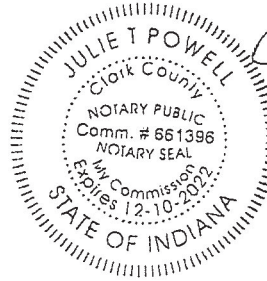

Julie T. Powell

Julie T. Powell
Notary Public, State of Indiana
Appointed in Clark County
Notary No. NP0661396
My commission expires: 12/10/2022

Prepared by:

Margaret F. Timmel

TIMMEL ASSOCIATES, LLC
Margaret F. Timmel (24546-22)
Jessica Richards (32844-22)
2733 Charlestown Rd.
New Albany, IN 47150
Telephone: (812)590-2771
Fax: (812)590-3634

Return recorded deed to:
TIMMEL ASSOCIATES, LLC
2733 Charlestown Rd.
New Albany, IN 47150

I affirm, under the penalties for perjury, that I have taken reasonable care to redact each Social Security number in this document, unless required by law. -Jessica Richards

EXHIBIT "A"

PARCEL NO. 1:

BEING A 1.1068 ACRE PART OF A 3.2403 ACRE TRACT OF LAND HERETOFORE CONVEYED TO MARYTRUE MULLINEAUX BY DEED AS RECORDED IN DRAWER 6, INSTRUMENT NO. 2580 OF THE FLOYD COUNTY, INDIANA RECORD OF DEEDS AND BEING A PART OF THE SOUTHWEST QUARTER OF SECTION 2, TOWNSHIP 3 SOUTH, RANGE 5 EAST, SITUATED IN GEORGETOWN TOWNSHIP, FLOYD COUNTY, INDIANA, AND BEING MORE FULLY DESCRIBED AS FOLLOWS, TO-WIT: COMMENCING AT AN IRON PIN AT THE NORTHEAST CORNER OF THE SOUTHWEST QUARTER OF SECTION 2, TOWNSHIP 3 SOUTH, RANGE 5 EAST, AND RUNNING THENCE NORTH 89 DEGREES 49' 55" WEST ALONG THE NORTH LINE OF SAID SOUTHWEST QUARTER, 110.80 FEET TO THE TRUE PLACE OF BEGINNING OF LAND TO BE HEREIN DESCRIBED: THENCE SOUTH 00 DEG. 36' 44" WEST, 415.15 FEET TO AN IRON PIN; THENCE NORTH 89 DEG. 49' 55" WEST, 150.00 FEET TO AN IRON PIN; THENCE NORTH 00 DEG. 36' 44" EAST 45.15 FEET TO AN IRON PIN; THENCE SOUTH 80 DEG. 49' 55" EAST, 38.00 FEET TO AN IRON PIN; THENCE NORTH 00 DEG. 36' 44" EAST, 37.00 FEET TO AN IRON PIN ON THE NORTH LINE OF SAID SOUTHWEST QUARTER; THENCE SOUTH 89 DEG. 49' 55" EAST ALONG SAID NORTH LINE, 112.00 FEET TO THE PLACE OF BEGINNING AND CONTAINING 1.1068 ACRES OF LAND. SUBJECT, HOWEVER, TO ALL THAT PART OF THE OLD CORYDON ROAD, A COUNTY ROAD, LIVING ON THE NORTH END OF THE ABOVE DESCRIBED 1.1068 ACRE PARCEL OF LAND.

PARCEL NO. 2

BEING A 16.8168 ACRE PART OF A 20 ACRE MORE OR LESS TRACT OF LAND HERETOFORE CONVEYED TO THOMAS L. MULLINEAUX AND MARYTRUE MULLINEAUX BY DEED AS RECORDED IN DEED RECORD 189 PAGE 471 OF THE FLOYD COUNTY, INDIANA RECORD OF DEEDS AND BEING A PART OF THE SOUTHWEST QUARTER OF SECTION NO. 2, TOWNSHIP 3 SOUTH, RANGE 5 EAST, SITUATED IN GEORGETOWN TOWNSHIP, FLOYD COUNTY, INDIANA, AND BEING MORE FULLY DESCRIBED AS FOLLOWS, TO-WIT: COMMENCING AT AN IRON PIN AT THE NORTHEAST CORNER OF THE SOUTHWEST QUARTER OF SECTION NO. 2, TOWNSHIP 3 SOUTH, RANGE 5 EAST AND RUNNING THENCE SOUTH 0 DEG. 36' 44" WEST ALONG THE EAST LINE OF SAID SOUTHWEST QUARTER, 415.15 FEET TO AN IRON PIN THE TRUE PLACE OF BEGINNING OF LAND TO BE HEREIN DESCRIBED: THENCE CONTINUING SOUTH 0 DEG. 36' 44" WEST ALONG SAID EAST LINE, 1570.56 FEET TO AN IRON PIN; THENCE NORTH 89 DEG. 49' 55" WEST, 440.00 FEET TO AN IRON PIN; THENCE NORTH 0 DEG. 36' 44" EAST, 1985.71 FEET TO AN IRON PIN ON THE NORTH LINE OF SAID SOUTHWEST QUARTER; THENCE SOUTH 89 DEG. 49' 55" EAST ALONG SAID NORTH LINE, 100.00 FEET TO AN IRON PIN; THENCE SOUTH 0 DEG. 36' 44" WEST, 415.15 FEET TO AN IRON PIN; THENCE SOUTH 89 DEG. 49' 55" EAST, 340.00 FEET TO THE PLACE OF BEGINNING AND CONTAINING 16.8168 ACRES OF LAND. SUBJECT, HOWEVER, TO ALL THAT PART OF THE OLD CORYDON ROAD, A COUNTY ROAD, LYING ON THE NORTH END OF THE ABOVE DESCRIBED 16.8168 ACRE PARCEL OF LAND. EXCEPTING THE FOLLOWING DESCRIBED REAL ESTATE: BEING A 15.0000 ACRE PART OF A 16.8168 ACRE TRACT OF LAND HERETOFORE CONVEYED TO MARYTRUE MULLINEAUX BY DEED AS RECORDED IN DEED DRAWER NO. 7, INSTRUMENT NO. 5867 OF THE FLOYD COUNTY, INDIANA RECORD OF DEEDS AND BEING A PART OF THE SOUTHWEST QUARTER OF SECTION NO. 2, TOWNSHIP 3 SOUTH, RANGE 5 EAST, SITUATED IN GEORGETOWN TOWNSHIP, FLOYD COUNTY, INDIANA AND BEING MORE FULLY DESCRIBED AS FOLLOWS, TO-WIT: COMMENCING AT AN IRON PIN AT THE NORTHEAST CORNER OF THE SOUTHWEST QUARTER OF SECTION NO. 2, TOWNSHIP 3 SOUTH, RANGE 5 EAST AND RUNNING THENCE SOUTH 00 DEGREES, 36 MINUTES, 44 SECONDS WEST ALONG THE EAST LINE OF SAID SOUTHWEST QUARTER, 647.91 FEET TO A POINT, THE TRUE PLACE OF BEGINNING OF LAND TO BE HEREIN DESCRIBED: THENCE CONTINUING SOUTH 00 DEGREES, 36 MINUTES, 44 SECONDS WEST ALONG SAID EAST LINE, 1337.80 FEET TO AN IRON PIN; THENCE NORTH 89 DEGREES, 49 MINUTES, 55 SECONDS WEST, 440.00 FEET TO AN IRON PIN; THENCE NORTH 00 DEGREES, 36 MINUTES, 44 SECONDS EAST, 1985.71 FEET TO AN IRON PIN ON THE NORTH LINE OF SAID SOUTHWEST QUARTER; THENCE SOUTH 89 DEGREES, 49 MINUTES, 55 SECONDS EAST ALONG THE NORTH LINE, 100.00 FEET TO AN IRON PIN; THENCE SOUTH 00 DEGREES, 36 MINUTES, 44 SECONDS WEST, 647.91 FEET TO A POINT; THENCE SOUTH 89 DEGREES, 49 MINUTES, 55 SECONDS EAST, 340.00 FEET TO THE PLACE OF BEGINNING AND CONTAINING 15.0000 ACRES OF LAND. SUBJECT, HOWEVER, TO ALL THAT PART OF THE OLD CORYDON ROAD, A COUNTY ROAD, LYING ON THE NORTH END OF THE ABOVE DESCRIBED 15.0000 ACRE PARCEL OF LAND. LEAVING 1.8168 ACRES.

ALSO: BEING A 3.2403 ACRE PART OF A 20 ACRE MORE OR LESS TRACT OF LAND HERETOFORE CONVEYED TO THOMAS L. MULLINEAUX AND MARYTRUE MULLINEAUX BY DEED AS RECORDED IN DEED RECORD 189 PAGE 471 OF THE FLOYD COUNTY, INDIANA RECORD OF DEEDS AND BEING A PART OF THE SOUTHWEST QUARTER OF SECTION NO. 2, TOWNSHIP 3 SOUTH, RANGE 5 EAST, SITUATED IN GEORGETOWN TOWNSHIP, FLOYD COUNTY, INDIANA AND BEING MORE FULLY DESCRIBED AS FOLLOWS, TO-WIT: BEGINNING AT AN IRON PIN AT THE NORTHEAST CORNER OF THE SOUTHWEST QUARTER OF

SECTION NO. 2, TOWNSHIP 3 SOUTH, RANGE 5 EAST AND RUNNING .THENCE SOUTH 0° 36' 44" WEST ALONG THE EAST LINE OF SAID SOUTHWEST QUARTER, 415.15 FEET TO AN IRON PIN; THENCE NORTH 89° 49' 55" WEST, 340.00 FEET TO AN IRON PIN; THENCE NORTH 0° 36' 44" EAST, 415.15 FEET TO AN IRON PIN ON THE NORTH LINE OF SAID SOUTHWEST QUARTER; THENCE SOUTH 89° 49' 55" EAST ALONG SAID NORTH LINE, 340.00 FEET TO THE PLACE OF BEGINNING AND CONTAINING 3.2403 ACRES OF LAND. SUBJECT, HOWEVER, TO ALL THAT PART OF THE OLD CORYDON ROAD, A COUNTY ROAD, LYING ON THE NORTH END OF THE ABOVE DESCRIBED 3.2403 ACRE PARCEL OF LAND. **EXCEPTING THE FOLLOWING DESCRIBED REAL ESTATE: BEING A 1.1068 ACRE PART OF A 3.2403 ACRE TRACT OF LAND HERETOFORE CONVEYED TO MARYTRUE MULLINEAUX BY DEED AS RECORDED IN DRAWER 6, INSTRUMENT NO. 2580 OF THE FLOYD COUNTY, INDIANA RECORD OF DEEDS AND BEING A PART OF THE SOUTHWEST QUARTER OF SECTION 2, TOWNSHIP 3 SOUTH, RANGE 5 EAST, SITUATED IN GEORGETOWN TOWNSHIP, FLOYD COUNTY, INDIANA, AND BEING MORE FULLY DESCRIBED AS FOLLOWS, TO-WIT: COMMENCING AT AN IRON PIN AT THE NORTHEAST CORNER OF THE SOUTHWEST QUARTER OF SECTION 2, TOWNSHIP 3 SOUTH, RANGE 5 EAST, AND RUNNING THENCE NORTH 89 DEGREES 49' 55" WEST ALONG THE NORTH LINE OF SAID SOUTHWEST QUARTER, 110.80 FEET TO THE TRUE PLACE OF BEGINNING OF LAND TO BE HEREIN DESCRIBED: THENCE SOUTH 00 DEG. 36' 44" WEST, 415.15 FEET TO AN IRON PIN; THENCE NORTH 89 DEG. 49' 55" WEST, 150.00 FEET TO AN IRON PIN; THENCE NORTH 00 DEG. 36' 44" EAST 45.15 FEET TO AN IRON PIN; THENCE SOUTH 80 DEG. 49' 55" EAST, 38.00 FEET TO AN IRON PIN; THENCE NORTH 00 DEG. 38' 44" EAST, 37.00 FEET TO AN IRON PIN ON THE NORTH LINE OF SAID SOUTHWEST QUARTER; THENCE SOUTH 89 DEG. 49' 55" EAST ALONG SAID NORTH LINE, 112.00 FEET TO THE PLACE OF BEGINNING AND CONTAINING 1.1068 ACRES OF LAND. SUBJECT, HOWEVER, TO ALL THAT PART OF THE OLD CORYDON ROAD, A COUNTY ROAD, LYING ON THE NORTH END OF THE ABOVE DESCRIBED 1.1068 ACRE PARCEL OF LAND. LEAVING 2.1385 ACRES**

Being the same property conveyed to Marilu Linderman and Chester D. Linderman as wife and husband, in a deed dated June 30, 2011, and recorded on July 7, 2011 as Instrument No. 201108900, in the Floyd County Recorder's Office.

**GENERAL DURABLE POWER OF ATTORNEY
OF
CHESTER LINDERMAN**

E-RECORDED
202208911
FLOYD CO. IN RECORDER
LOIS ENDRIS
07/26/2022 09:29 AM
202208911 Pages: 4
Transaction # 4062482

BY THIS POWER OF ATTORNEY, I name my Attorney-in-Fact with power to act on my behalf pursuant to Indiana Code 30-5, as it exists now and is amended in the future.

ATTORNEY-IN-FACT. As my Attorney-in-Fact, I name my wife, **Marilu Linderman**, and my son, **Edward Adam Linderman**, to serve concurrently, each individually with the authority to act on my behalf.

LIABILITY LIMITED. My Attorney-in-Fact shall only be liable for actions undertaken in bad faith.

FEE. My Attorney-in-Fact shall be entitled to no fee for services provided as my Attorney-in-Fact, but shall be entitled to recover expenses.

EFFECTIVE IMMEDIATELY. This power of attorney shall be effective as of the day it is signed.

POWERS. I give to my Attorney-in-Fact the powers specified in this section to be used on my behalf, provided that my Attorney-in-Fact shall not have any power which would cause my Attorney-in-Fact to be treated as the owners of any interest in my property:

1. **REAL PROPERTY.** Authority with respect to real property transactions pursuant to Indiana Code 30-5-5-2.
2. **TANGIBLE PERSONAL PROPERTY.** Authority with respect to tangible personal property pursuant to Indiana Code 30-5-5-3.
3. **BOND, SHARE AND COMMODITY.** Authority with respect to bond, share, and commodity transactions pursuant to Indiana Code 30-5-5-4.
4. **BANKING.** Authority with respect to banking transactions pursuant to Indiana Code 30-5-5-5.
5. **RETIREMENT PLANS.** Authority with respect to Retirement Plans pursuant to Indiana Code 30-5-5-4.5.
6. **BUSINESS.** Authority with respect to business operating transactions pursuant to Indiana Code 30-5-5-6.
7. **INSURANCE.** Authority with respect to insurance transactions pursuant to Indiana Code 30-5-5-7 provided that references in Indiana Code 30-5-5-7(a)(2) and (3) to "section 8" are changed to "section 9". I specifically grant to my Attorney-in-Fact authority to change the beneficiary on any policy of insurance, including life insurance.
8. **BENEFICIARY.** Authority with respect to beneficiary transactions pursuant to Indiana Code 30-5-5-8.
9. **GIFTS.** Authority with respect to gift transactions pursuant to Indiana Code 30-5-5-9, except that the limitations set forth in Indiana Code 30-5-5-9(a)(2) are hereby waived. Said power shall include the unlimited power to make gifts, outright or in trust, to benefit those I have provided for in any will, trust, beneficiary designation, payable on death, in trust for or jointly held with rights of survivorship accounts or heirs at law, for probate avoidance, asset protection, tax reduction, or to qualify me for resource-based

General Durable Power of Attorney
Chester Linderman
Page 1 of 4

government benefits, if, in the opinion of my Attorney-in-Fact after consultation with a qualified professional, such action is in my best interests. The authority conferred with respect to gift transaction shall also include the power to alter the beneficiaries of a revocable trust of which I am Settlor to effectuate, in substance, a gift of my beneficial interest to my spouse in whole or in part; and this authority also includes the power to direct the Trustee of a revocable trust of which I am Settlor to transfer the assets to be gifted out of the trust to my Attorney-in-Fact for the purpose of making gift(s) or to make such gifts directly from the trust. In all exercises of gift transaction powers, my Attorney-in-Fact shall take into account the potential effect of gift or bargain transfers on my existing or future eligibility for Medicaid and other public benefits programs.

10. FIDUCIARY. Authority with respect to fiduciary transactions pursuant to Indiana Code 30-5-5-10.
11. CLAIMS AND LITIGATION. Authority with respect to claims and litigation pursuant to Indiana Code 30-5-5-11.
12. FAMILY MAINTENANCE. Authority with respect to family maintenance pursuant to Indiana Code 30-5-5-12.
13. MILITARY SERVICE. Authority with respect to benefits from military service pursuant to Indiana Code 30-5-5-13, including authority to act on behalf of the principal with regard to application, acceptance, receipt, or any other matter associated with the Veterans' Administration.
14. RECORDS, REPORTS AND STATEMENTS. Authority with respect to records reports and statements pursuant to Indiana Code 30-5-5-14, including the power to execute on my behalf any specific power of attorney required by any taxing authority to allow my Attorney-in-Fact to act on my behalf before any taxing authority on any return or issue.
15. ESTATE TRANSACTIONS. Authority with respect to estate transactions pursuant to Indiana Code 30-5-5-15, including the authority to exercise all powers with respect to estates and trusts, including but not limited to the authority to create, fund, amend, revoke, or terminate a revocable or irrevocable inter vivos trust.
16. HEALTH CARE. I have executed or will later execute an Appointment of Health Care Representative pursuant to Indiana Code 16-36-1 et seq., and it is my intention that the designee named therein shall have authority with respect to health care pursuant to Indiana Code 30-5-5-16 and 30-5-5-17.
17. DELEGATE. Authority with respect to delegating authority pursuant to Indiana Code 30-5-5-18.
18. ALL OTHER MATTERS. Authority with respect to all other matters pursuant to Indiana Code 30-5-5-19.

GUARDIANSHIP. If it becomes necessary to secure the appointment of a guardian of my person or estate, or if protective proceedings are filed on my behalf, I hereby request that the appropriate probate court appoint my wife, **Marilu Linderman**, or my son, **Edward Adam Linderman**, in order of preference, as my guardian or as the person to act on my behalf.

SUPERSEDES PRIOR POWERS OF ATTORNEY. This Power of Attorney supersedes all other powers of attorney I have executed prior to the date of this Power of Attorney.

General Durable Power of Attorney
Chester Linderman
Page 2 of 4

RELIANCE BY THIRD PARTIES ON AGENT. Those to whom this Power of Attorney is presented may rely upon the following:

1. a copy of the original document;
2. a signed notarized statement of the Agent that this Power of Attorney has not been revoked and that it is otherwise in effect;
3. a written notarized statement of my successor Agent that the original Agent is unable or unwilling to serve.

As consideration for this reliance, I agree to defend, indemnify, and hold harmless anyone whose reliance is reasonable and who is without actual knowledge that the copy is not valid or that the statement is not true.

REVOCAION OF POWER. This Power of Attorney may be revoked by me only by a written instrument of revocation that (1) identifies this Power of Attorney and (2) is signed by me in the presence of a notary. This revocation is not effective unless my Attorney-in-Fact has actual knowledge of the revocation. If this Power of Attorney was recorded, the revocation must be (1) recorded in the county where the Power of Attorney was recorded and (2) reference the book and page or instrument number where this Power of Attorney was recorded.

TERMINATION AT DEATH. Without regard to my mental or physical condition, this Power of Attorney shall continue in effect until revoked or until my death, whichever occurs first.

I have executed this instrument on this 7th day of September, 2021.



Chester Linderman

STATE OF INDIANA)
) ss.
COUNTY OF FLOYD)

The undersigned, a Notary Public, in and for said Floyd County, Indiana, certifies and witnesses that the above signed, personally known to me to be the same person whose name is subscribed to this instrument, appeared before me in person and acknowledged the signature and delivered the instrument as a free and voluntary act, for the uses and purposes named in the instrument.

My Commission Expires:

December 10, 2022

County of Residence:

Clark County

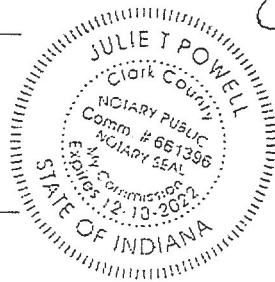

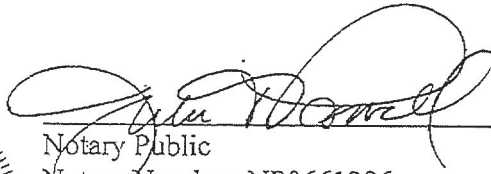

Notary Public
Notary Number: NP0661396

Julie T. Powell
Printed

Document prepared by:

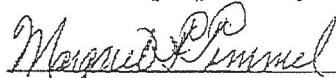

Margaret F. Timmel, Esq. (24546-22)
Jessica A. Richards, Esq. (32844-22)
TIMMEL LAW LLC
2733 Charlestown Rd.
New Albany, Indiana 47150
Phone: (812) 590-2771, Fax: (812) 590-3634

I affirm, under the penalties for perjury, that I have taken reasonable care to redact each Social Security number in this document, unless required by law. -Jessica Richards

General Durable Power of Attorney
Chester Linderman
Page 4 of 4

JUL 07 2011



* 2 0 1 1 0 8 9 0 0 4 *
FLOYD CO. IN RECORDER - LOIS ENDRIS
07/07/2011 09:16:25AM
201108900 Pages:4
Transaction # 16589
Fee Amount: \$22.00

Parcel No. 002-06100-68 (1.1068 Acres)
State No. 22-02-00-200-124.000-002
Parcel No. 002-06100-66 (2.1385 Acres)
State No. 22-02-00-200-122.000-002
Parcel No. 002-06100-67 (1.8168 Acres)
State No. 22-02-00-200-123.000-002

QUITCLAIM DEED

THIS INDENTURE WITNESSETH, this deed is made this 30th day of June, 2011, by and between Marilu Linderman and Chester D. Linderman, wife and husband, whose mailing address is 6527 Corydon Ridge Road, Georgetown, Indiana 47122, Grantors; and Marilu Linderman and Chester D. Linderman, wife and husband, whose tax mailing address is 6527 Corydon Ridge Road, Georgetown, Indiana 47122, Grantees;

WITNESSETH: That for the VALUABLE CONSIDERATION in the amount of One Dollar (\$1.00), and other good and valuable consideration, the receipt and sufficiency of which are hereby acknowledged, the Grantor conveys and quitclaims to the Grantees a fee simple estate, to hold as tenants by the entireties, in and to the following described real property, together with all improvements, located in Floyd County, Indiana, being more particularly described as follows (the "Property"):

SEE THE ATTACHED EXHIBIT "A" FOR THE LEGAL DESCRIPTION AND CONVEYANCE INFORMATION FOR THE SUBJECT PROPERTY WHICH IS INCORPORATED HEREIN BY REFERENCE AND MADE A PART OF THIS DOCUMENT.

IN TESTIMONY WHEREOF, witness the signatures of Marilu Linderman and Chester D. Linderman, Grantors, and Marilu Linderman and Chester D. Linderman, Grantees.

Duly Entered For Taxation
Subject To Final Acceptance
For Transfer

JUL 07 2011

AUDITOR FLOYD CO. IND.

Grantors:

Grantees:

Marilu Linderman
Marilu Linderman

Marilu Linderman
Marilu Linderman

Chester D. Linderman
Chester D. Linderman

Chester D. Linderman
Chester D. Linderman

State of Indiana)
County of Floyd) SS:

This deed was acknowledged, subscribed and sworn to before me, a notary public, this 30th day of June, 2011, by Marilu Linderman and Chester D. Linderman, Grantors, and Marilu Linderman and Chester D. Linderman, Grantees.

My commission expires: 1/16/2016

Kristin A. Nolot
Notary Public, State at Large, Indiana

County of Residence: Harrison

Name Printed: Kristin A. Nolot

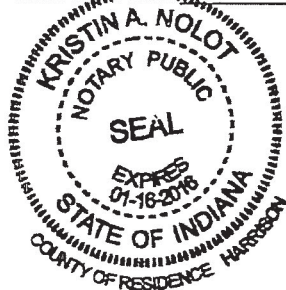

Certification: I affirm, under the penalties of perjury, that I have taken reasonable care to redact each social security number in this document, unless required by law. James M. Kemp, Esq.

Pursuant to I.C. 32-21-2-3(b), the mailing address for the Grantees' property tax statements is: 6527 Corydon Ridge Rd., Georgetown, Indiana 47122

When Recorded, Return To: Kemp Title Agency, LLC, 4206 Charlestown Road, Suite 100, New Albany, Indiana 47150, 812-941-8980, File #201106035

This instrument was prepared without title examination or other legal services by: Kemp Law Office, LLC, By: James M. Kemp, Esq., 4206 Charlestown Road, Suite 100, New Albany, Indiana 47150.

EXHIBIT "A"

PARCEL NO. 1:

BEING A 1.1068 ACRE PART OF A 3.2403 ACRE TRACT OF LAND HERETOFORE CONVEYED TO MARYTRUE MULLINEAUX BY DEED AS RECORDED IN DRAWER 6, INSTRUMENT NO. 2580 OF THE FLOYD COUNTY, INDIANA RECORD OF DEEDS AND BEING A PART OF THE SOUTHWEST QUARTER OF SECTION 2, TOWNSHIP 3 SOUTH, RANGE 5 EAST, SITUATED IN GEORGETOWN TOWNSHIP, FLOYD COUNTY, INDIANA, AND BEING MORE FULLY DESCRIBED AS FOLLOWS, TO-WIT: COMMENCING AT AN IRON PIN AT THE NORTHEAST CORNER OF THE SOUTHWEST QUARTER OF SECTION 2, TOWNSHIP 3 SOUTH, RANGE 5 EAST, AND RUNNING THENCE NORTH 89 DEGREES 49' 55" WEST ALONG THE NORTH LINE OF SAID SOUTHWEST QUARTER, 110.80 FEET TO THE TRUE PLACE OF BEGINNING OF LAND TO BE HEREIN DESCRIBED: THENCE SOUTH 00 DEG. 36' 44" WEST, 415.15 FEET TO AN IRON PIN; THENCE NORTH 89 DEG. 49' 55" WEST, 150.00 FEET TO AN IRON PIN; THENCE NORTH 00 DEG. 36' 44" EAST 45.15 FEET TO AN IRON PIN; THENCE SOUTH 80 DEG. 49' 55" EAST, 38.00 FEET TO AN IRON PIN; THENCE NORTH 00 DEG. 36' 44" EAST, 37.00 FEET TO AN IRON PIN ON THE NORTH LINE OF SAID SOUTHWEST QUARTER; THENCE SOUTH 89 DEG. 49' 55" EAST ALONG SAID NORTH LINE, 112.00 FEET TO THE PLACE OF BEGINNING AND **CONTAINING 1.1068 ACRES OF LAND.** SUBJECT, HOWEVER, TO ALL THAT PART OF THE OLD CORYDON ROAD, A COUNTY ROAD, LIVING ON THE NORTH END OF THE ABOVE DESCRIBED 1.1068 ACRE PARCEL OF LAND.

PARCEL NO. 2

BEING A 16.8168 ACRE PART OF A 20 ACRE MORE OR LESS TRACT OF LAND HERETOFORE CONVEYED TO THOMAS L. MULLINEAUX AND MARYTRUE MULLINEAUX BY DEED AS RECORDED IN DEED RECORD 189 PAGE 471 OF THE FLOYD COUNTY, INDIANA RECORD OF DEEDS AND BEING A PART OF THE SOUTHWEST QUARTER OF SECTION NO. 2, TOWNSHIP 3 SOUTH, RANGE 5 EAST, SITUATED IN GEORGETOWN TOWNSHIP, FLOYD COUNTY, INDIANA, AND BEING MORE FULLY DESCRIBED AS FOLLOWS, TO-WIT: COMMENCING AT AN IRON PIN AT THE NORTHEAST CORNER OF THE SOUTHWEST QUARTER OF SECTION NO. 2, TOWNSHIP 3 SOUTH, RANGE 5 EAST AND RUNNING THENCE SOUTH 0 DEG. 36' 44" WEST ALONG THE EAST LINE OF SAID SOUTHWEST QUARTER, 415.15 FEET TO AN IRON PIN THE TRUE PLACE OF BEGINNING OF LAND TO BE HEREIN DESCRIBED: THENCE CONTINUING SOUTH 0 DEG. 36' 44" WEST ALONG SAID EAST LINE, 1570.56 FEET TO AN IRON PIN; THENCE NORTH 89 DEG. 49' 55" WEST, 440.00 FEET TO AN IRON PIN; THENCE NORTH 0 DEG. 36' 44" EAST, 1985.71 FEET TO AN IRON PIN ON THE NORTH LINE OF SAID SOUTHWEST QUARTER; THENCE SOUTH 89 DEG. 49' 55" EAST ALONG SAID NORTH LINE, 100.00 FEET TO AN IRON PIN; THENCE SOUTH 0 DEG. 36' 44" WEST, 415.15 FEET TO AN IRON PIN; THENCE SOUTH 89 DEG. 49' 55" EAST, 340.00 FEET TO THE PLACE OF BEGINNING AND CONTAINING 16.8168 ACRES OF LAND. SUBJECT, HOWEVER, TO ALL THAT PART OF THE OLD CORYDON ROAD, A COUNTY ROAD, LYING ON THE NORTH END OF THE ABOVE DESCRIBED 16.8168 ACRE PARCEL OF LAND. **EXCEPTING THE FOLLOWING DESCRIBED REAL ESTATE:** BEING A 15.0000 ACRE PART OF A 16.8168 ACRE TRACT OF LAND HERETOFORE CONVEYED TO MARYTRUE MULLINEAUX BY DEED AS RECORDED IN DEED DRAWER NO. 7, INSTRUMENT NO. 5867 OF THE FLOYD COUNTY, INDIANA RECORD OF DEEDS AND BEING A PART OF THE SOUTHWEST QUARTER OF SECTION NO. 2, TOWNSHIP 3 SOUTH, RANGE 5 EAST, SITUATED IN GEORGETOWN TOWNSHIP, FLOYD COUNTY, INDIANA AND BEING MORE FULLY DESCRIBED AS FOLLOWS, TO-WIT: COMMENCING AT AN IRON PIN AT THE NORTHEAST CORNER OF THE SOUTHWEST QUARTER OF SECTION NO. 2, TOWNSHIP 3 SOUTH, RANGE 5 EAST AND RUNNING THENCE SOUTH 00 DEGREES, 36 MINUTES, 44 SECONDS WEST ALONG THE EAST LINE OF SAID SOUTHWEST QUARTER, 647.91 FEET TO A POINT, THE TRUE PLACE OF BEGINNING OF LAND TO BE HEREIN DESCRIBED: THENCE CONTINUING SOUTH 00 DEGREES, 36 MINUTES, 44 SECONDS WEST ALONG SAID EAST LINE, 1337.80 FEET TO AN IRON PIN; THENCE NORTH 89 DEGREES, 49 MINUTES, 55 SECONDS WEST, 440.00 FEET TO AN IRON PIN; THENCE NORTH 00 DEGREES, 36 MINUTES, 44 SECONDS EAST, 1985.71 FEET TO AN IRON PIN ON THE NORTH LINE OF SAID SOUTHWEST QUARTER; THENCE SOUTH 89 DEGREES, 49 MINUTES, 55 SECONDS EAST ALONG THE NORTH LINE, 100.00 FEET TO AN IRON PIN; THENCE SOUTH 00 DEGREES, 36 MINUTES, 44 SECONDS WEST, 647.91 FEET TO A POINT; THENCE SOUTH 89 DEGREES, 49 MINUTES, 55 SECONDS EAST, 340.00 FEET TO THE PLACE OF BEGINNING AND CONTAINING 15.0000 ACRES OF LAND. SUBJECT, HOWEVER, TO ALL THAT PART OF THE OLD CORYDON ROAD, A COUNTY ROAD, LYING ON THE NORTH END OF THE ABOVE DESCRIBED 15.0000 ACRE PARCEL OF LAND. **LEAVING 1.8168 ACRES.**

ALSO: BEING A 3.2403 ACRE PART OF A 20 ACRE MORE OR LESS TRACT OF LAND HERETOFORE CONVEYED TO THOMAS L. MULLINEAUX AND MARYTRUE MULLINEAUX BY DEED AS RECORDED IN DEED RECORD 189 PAGE 471 OF THE FLOYD COUNTY, INDIANA RECORD OF DEEDS AND BEING A PART OF THE SOUTHWEST QUARTER OF SECTION NO. 2, TOWNSHIP 3 SOUTH, RANGE 5 EAST, SITUATED IN GEORGETOWN TOWNSHIP, FLOYD COUNTY, INDIANA AND BEING MORE FULLY DESCRIBED AS FOLLOWS, TO-WIT: BEGINNING AT AN IRON PIN AT THE NORTHEAST CORNER OF THE SOUTHWEST QUARTER OF

SECTION NO. 2, TOWNSHIP 3 SOUTH, RANGE 5 EAST AND RUNNING THENCE SOUTH 0° 36' 44" WEST ALONG THE EAST LINE OF SAID SOUTHWEST QUARTER, 415.15 FEET TO AN IRON PIN; THENCE NORTH 89° 49' 55" WEST, 340.00 FEET TO AN IRON PIN; THENCE NORTH 0° 36' 44" EAST, 415.15 FEET TO AN IRON PIN ON THE NORTH LINE OF SAID SOUTHWEST QUARTER; THENCE SOUTH 89° 49' 55" EAST ALONG SAID NORTH LINE, 340.00 FEET TO THE PLACE OF BEGINNING AND CONTAINING 3.2403 ACRES OF LAND. SUBJECT, HOWEVER, TO ALL THAT PART OF THE OLD CORYDON ROAD, A COUNTY ROAD, LYING ON THE NORTH END OF THE ABOVE DESCRIBED 3.2403 ACRE PARCEL OF LAND. **EXCEPTING THE FOLLOWING DESCRIBED REAL ESTATE:** BEING A 1.1068 ACRE PART OF A 3.2403 ACRE TRACT OF LAND HERETOFORE CONVEYED TO MARYTRUE MULLINEAUX BY DEED AS RECORDED IN DRAWER 6, INSTRUMENT NO. 2580 OF THE FLOYD COUNTY, INDIANA RECORD OF DEEDS AND BEING A PART OF THE SOUTHWEST QUARTER OF SECTION 2, TOWNSHIP 3 SOUTH, RANGE 5 EAST, SITUATED IN GEORGETOWN TOWNSHIP, FLOYD COUNTY, INDIANA, AND BEING MORE FULLY DESCRIBED AS FOLLOWS, TO-WIT: COMMENCING AT AN IRON PIN AT THE NORTHEAST CORNER OF THE SOUTHWEST QUARTER OF SECTION 2, TOWNSHIP 3 SOUTH, RANGE 5 EAST, AND RUNNING THENCE NORTH 89 DEGREES 49' 55" WEST ALONG THE NORTH LINE OF SAID SOUTHWEST QUARTER, 110.80 FEET TO THE TRUE PLACE OF BEGINNING OF LAND TO BE HEREIN DESCRIBED: THENCE SOUTH 00 DEG. 36' 44" WEST, 415.15 FEET TO AN IRON PIN; THENCE NORTH 89 DEG. 49' 55" WEST, 150.00 FEET TO AN IRON PIN; THENCE NORTH 00 DEG. 36' 44" EAST 45.15 FEET TO AN IRON PIN; THENCE SOUTH 80 DEG. 49' 55" EAST, 38.00 FEET TO AN IRON PIN; THENCE NORTH 00 DEG. 36' 44" EAST, 37.00 FEET TO AN IRON PIN ON THE NORTH LINE OF SAID SOUTHWEST QUARTER; THENCE SOUTH 89 DEG. 49' 55" EAST ALONG SAID NORTH LINE, 112.00 FEET TO THE PLACE OF BEGINNING AND CONTAINING 1.1068 ACRES OF LAND. SUBJECT, HOWEVER, TO ALL THAT PART OF THE OLD CORYDON ROAD, A COUNTY ROAD, LYING ON THE NORTH END OF THE ABOVE DESCRIBED 1.1068 ACRE PARCEL OF LAND. LEAVING 2.1385 ACRES

Being the same property conveyed to Chester D. Linderman and Marilu Linderman, by deed dated 2/20/92 and recorded 2/21/92, of record in Deed Drawer 19, Instrument Number 2018, and by deed dated 2/24/92 and recorded 2/25/92, of record in Deed Drawer 19, Instrument Number 2179, in the Office of the recorder of Floyd County, Indiana.

Certification: I affirm, under the penalties of perjury, that I have taken reasonable care to redact each social security number in this document, unless required by law. James M. Kemp; Esq.

Pursuant to I.C. 32-21-2-3(b), the mailing address for the Grantees' property tax statements is: 6527 Corydon Ridge Rd., Georgetown, Indiana 47122

When Recorded, Return To: Kemp Title Agency, LLC, 4206 Charlestown Road, Suite 100, New Albany, Indiana 47150, 812-941-8980, File #201106035

This instrument was prepared without title examination or other legal services by: Kemp Law Office, LLC, By: James M. Kemp, Esq., 4206 Charlestown Road, Suite 100, New Albany, Indiana 47150.



Revision	Date	By
4:		
3:		
2:		
1:		

SITE SKETCH
 ELDER COMPANY
 CORYDON RIDGE ROAD
 GEORGETOWN, IN
 FLOYD COUNTY

301 E. CHESTNUT ST.
 CORYDON, IN 47112
 TEL: (812) 738-4124
 FAX: (812) 738-6740

PAUL PRIMAVERA & ASSOCIATES

Date: 04/03/2024
 Drafted By: JMC
 Checked By: DAS
 Directory:
 T: \2024\24890\
 File: 24890SKETCH.D
 Job No.: 24-24890
 Drawing No.
1 OF 1

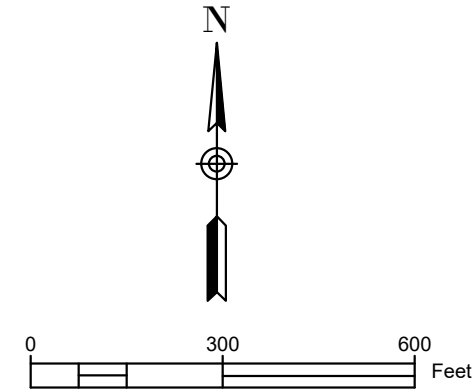
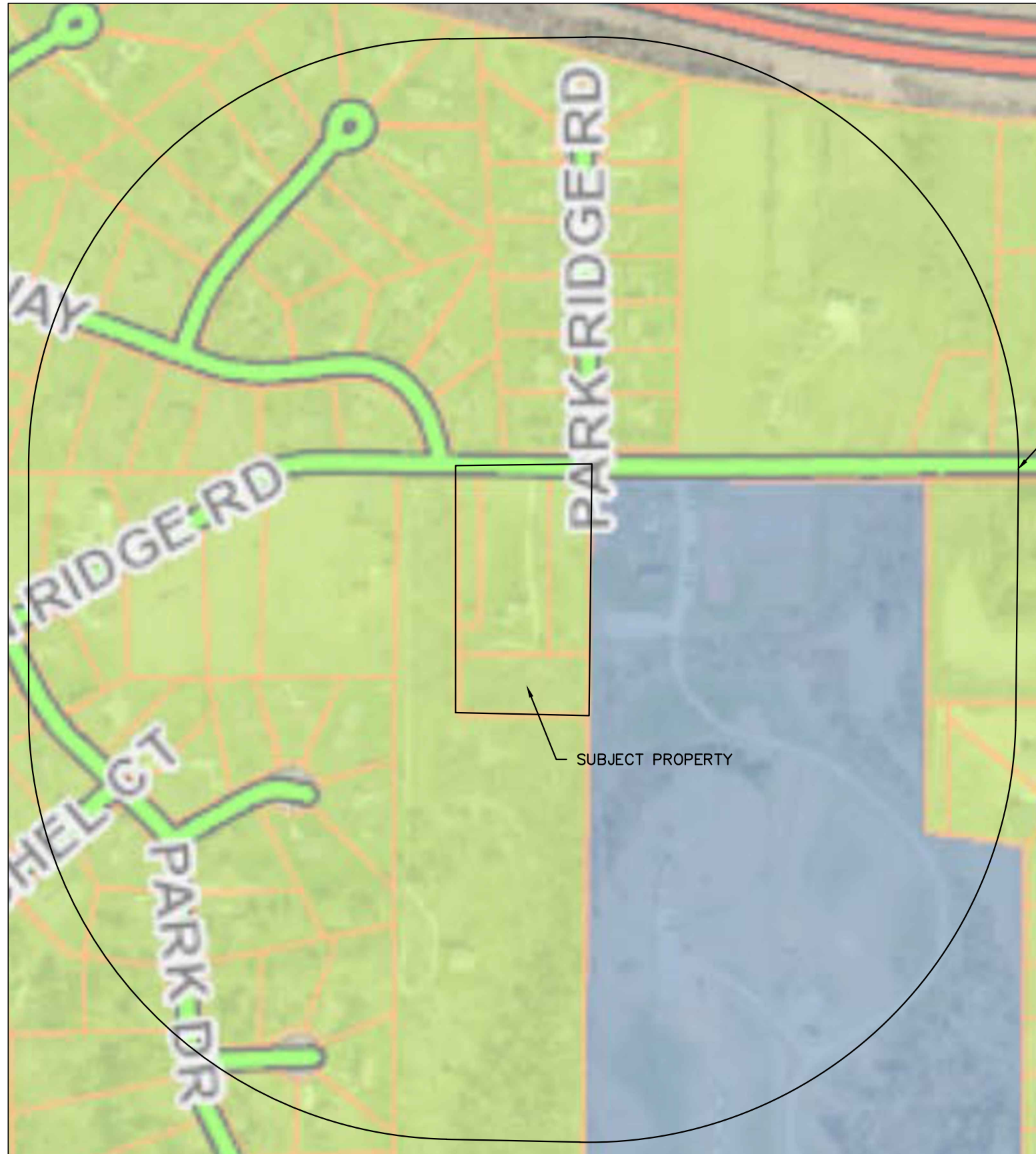

LEGEND

- AR - Agriculture
- RR - Rural Residential
- RS - Residential Suburban
- RU - Residential Urban
- MF - Multi-Family
- NC - Neighborhood Commercial
- HS - Highway Service
- GC - General Commercial
- PR - Park
- GI - General Industrial
- OB - Office Business
- PU - Plan Unit

Revision	Date	By
4:		
3:		
2:		
1:		

ZONE MAP
 ELDER COMPANY
 CORYDON RIDGE ROAD
 GEORGETOWN, IN
 FLOYD COUNTY

6527

301 E. CHESTNUT ST.
 CORYDON, IN 47112
 TEL: (812) 738-4124
 FAX: (812) 738-6740

PAUL PRIMAVERA
& ASSOCIATES

Date:	04/16/2024
Drafted By:	JMC
Checked By:	DAS
Directory:	T:\2024\24890\
File:	24890ZONEMAP
Job No.:	24-24890
Drawing No.	1 OF 1

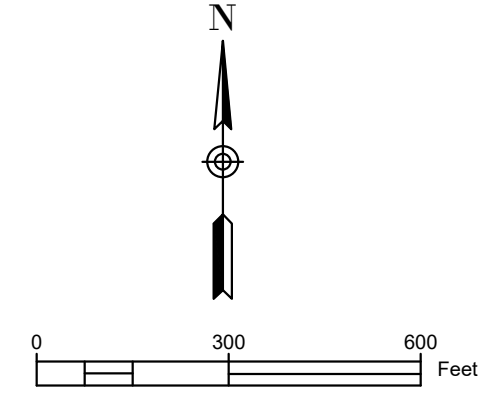

1000' FROM PROPERTY

Revision	Date	By
4:		
3:		
2:		
1:		

USE MAP
 ELDER COMPANY
 CORYDON RIDGE ROAD
 GEORGETOWN, IN
 FLOYD COUNTY
 6527

301 E. CHESTNUT ST.
 CORYDON, IN 47112
 TEL: (812) 738-4124
 FAX: (812) 738-6740

PAUL PRIMAVERA
& ASSOCIATES

Date: 04/16/2024

Drafted By: JMC

Checked By: DAS

Directory:
 T:\2024\24890\

File: 24890ZONEMAP

Job No.: 24-24890

Drawing No.

1 OF 1



February 21, 2024

Mr. Jake Elder
The Elder Company
501 E. Pearl Street
New Albany, IN 47150

Re: Sanitary Sewer Service and Capacity – 6527 Corydon Ridge Road (Proposed Development)

Dear Mr. Elder:

The Town is in receipt of your request for sanitary sewer service at 6527 Corydon Ridge Road (Parcel No. 22-02-00-200-124.000-002). Please accept this letter as verification the Town of Georgetown currently provides sanitary sewer service to this area. It is our understanding this development will consist roughly of the following:

Single Family Units 20 @ 310 gpd/unit = 6,200 gpd

As discussed with you on the phone (and via emails), the nearest Town facilities to this parcel are existing dual 4-inch force mains running within the right of way of Corydon Ridge Road. Connection to these mains will require a low pressure sewer system. The Town is acceptable to allowing a low pressure sewer system to be installed to serve your proposed development.

A summary of the Town’s known future developments with the total lots remaining to be developed:

Brookstone 4	15 lots	4,650 gpd	Under construction
Knob Hill Future Phases	155 lots	48,050 gpd	Construction has not yet begun.
Grove Apartments	32 units	8,320 gpd	Units now being leased.
Gateway Village Apts	120 units	31,200 gpd	Under construction
Henriott Meadows	40 lots	12,400 gpd	Under construction
Poplar Woods	45 lots	13,950 gpd	Under construction
Springs of Old Gtwn	30 lots	9,300 gpd	Under construction
Westfield Springs	20 lots	<u>6,200 gpd</u>	Under construction
		134,070 gpd	

WWTP Available and Future Capacity Summary

Current WWTP Rated Capacity	7000,000 gpd	
Current Average Daily Flow (2023)	<u>278,000 gpd</u>	40% capacity of WWTP
Current Available Capacity	422,000 gpd	
Future Flows (Current + Future)	418,270 gpd	

The Town’s WWTP currently has sufficient capacity available to serve the full buildout of your proposed residential development and the other proposed/active developments.

Please contact my office should you require additional information.

Sincerely,

Robert L. Woosley Jr., P.E.
Town Engineer