

724-B-147d 1

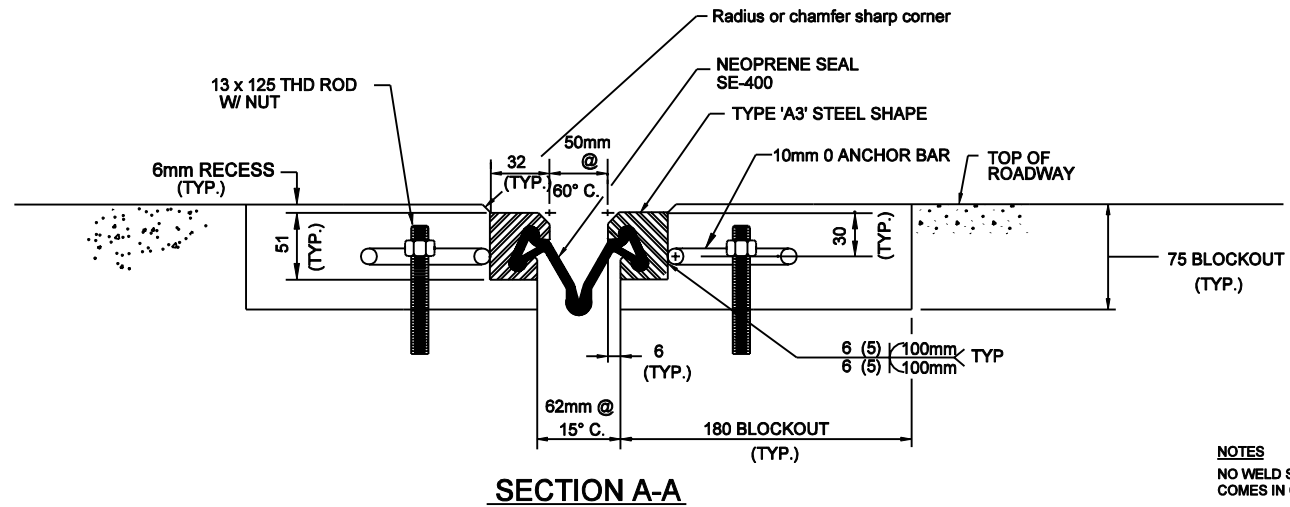
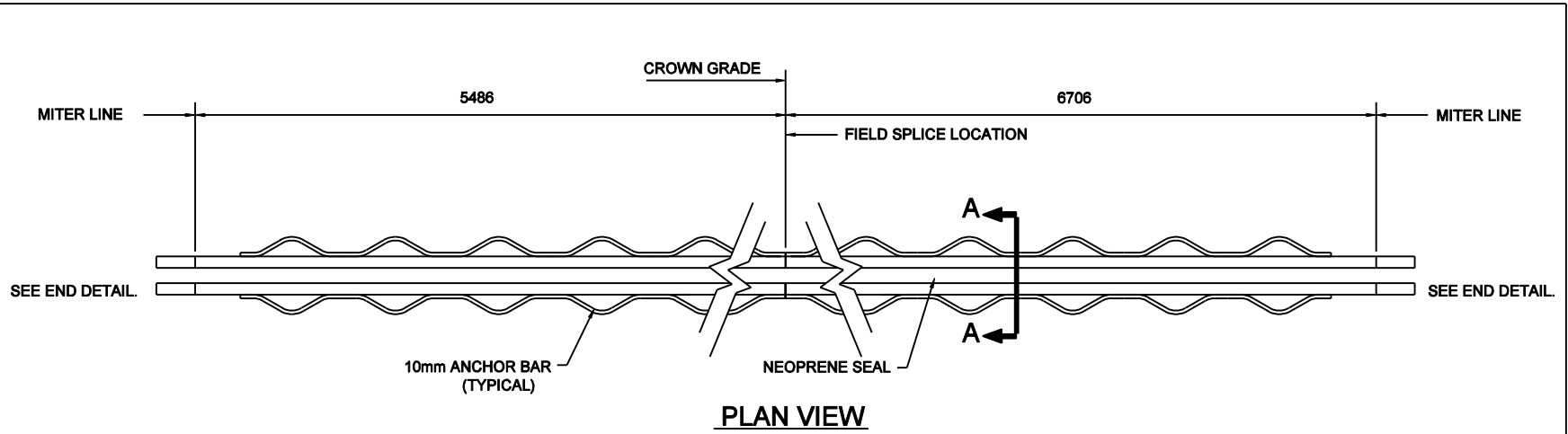

NOTES
 NO WELD SHALL BE PERMITTED WHERE STEEL SHAPE COMES IN CONTACT WITH THE NEOPRENE SEAL.
 ALL WELDING SHALL BE IN ACCORDANCE WITH THE CURRENT STRUCTURAL WELDING CODE ANSI/AASHTO/AWS D1.5-88 AND THE CONTRACT SPECIFICATIONS.

All Dimension are in mm unless otherwise specified
 INDIANA DEPARTMENT OF TRANSPORTATION
 ALTERNATE SS JOINT
 1-22-01

724-B-147d 2

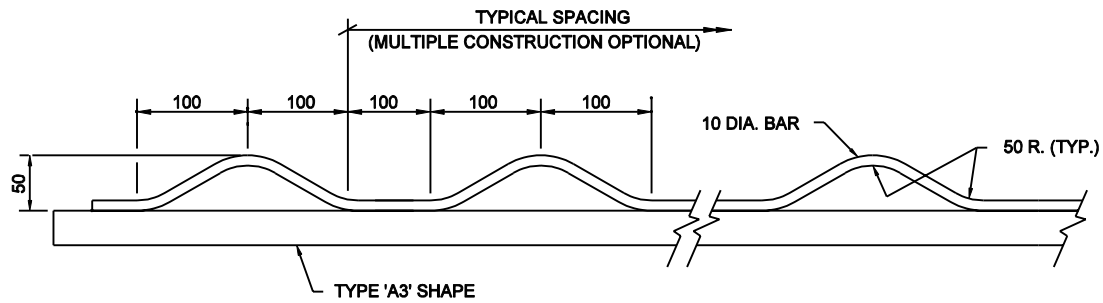

ANCHOR BAR DETAIL

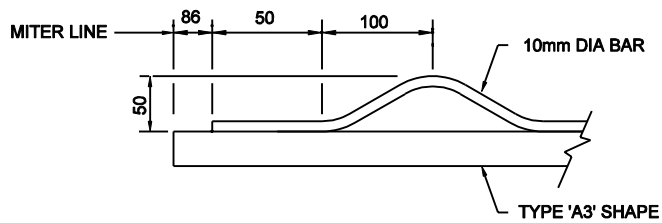

END DETAIL

NOTES

NO WELD SHALL BE PERMITTED WHERE STEEL SHAPE COMES IN CONTACT WITH THE NEOPRENE SEAL.

ALL WELDING SHALL BE IN ACCORDANCE WITH THE CURRENT STRUCTURAL WELDING CODE ANSI/AASHTO/AWS D1.5-88 AND THE CONTRACT SPECIFICATIONS.

All Dimension are in mm unless otherwise specified

INDIANA DEPARTMENT OF TRANSPORTATION

ALTERNATE SS JOINT

1-22-01

E 724-B-147d 1

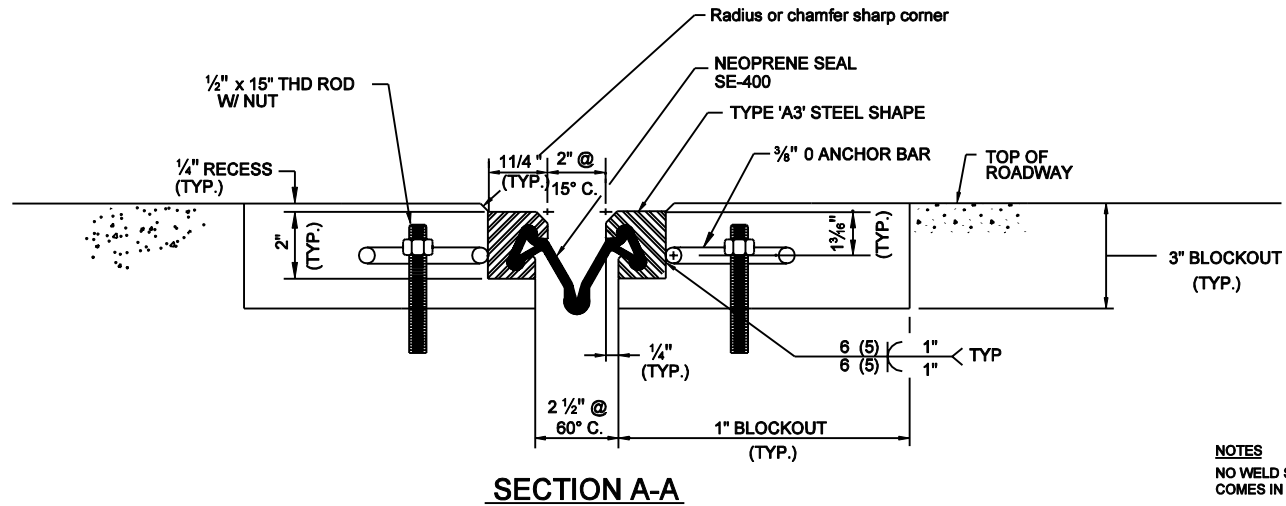
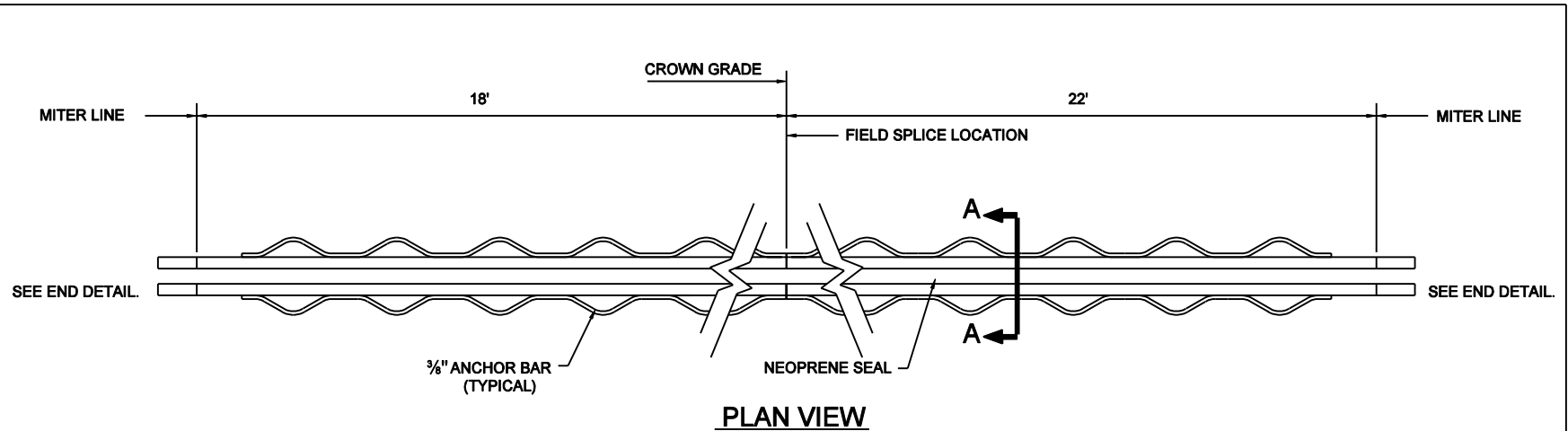

NOTES

NO WELD SHALL BE PERMITTED WHERE STEEL SHAPE COMES IN CONTACT WITH THE NEOPRENE SEAL.

ALL WELDING SHALL BE IN ACCORDANCE WITH THE CURRENT STRUCTURAL WELDING CODE ANSI/AASHTO/AWS D1.5-88 AND THE CONTRACT SPECIFICATIONS.

INDIANA DEPARTMENT OF TRANSPORTATION
ALTERNATE SS JOINT

1-22-01

E 724-B-147D 2

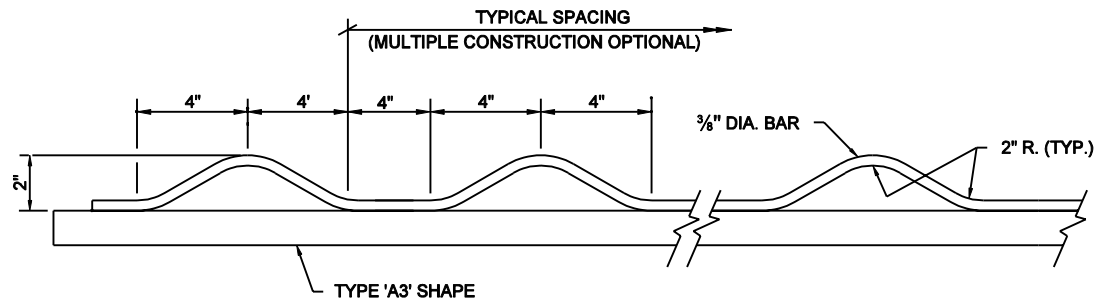

ANCHOR BAR DETAIL

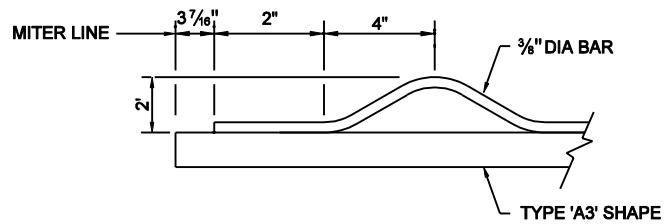

END DETAIL

NOTES

NO WELD SHALL BE PERMITTED WHERE STEEL SHAPE COMES IN CONTACT WITH THE NEOPRENE SEAL.

ALL WELDING SHALL BE IN ACCORDANCE WITH THE CURRENT STRUCTURAL WELDING CODE ANSI/AASHTO/AWS D1.5-88 AND THE CONTRACT SPECIFICATIONS.

INDIANA DEPARTMENT OF TRANSPORTATION

ALTERNATE SS JOINT

1-22-01