

PAY LIMITS FOR HMA FOR APPROACHES

**PUBLIC ROAD APPROACH TYPE A**

**NOTES :**

- ① 90 kg/m<sup>2</sup> HMA Surface Type A on  
150 kg/m<sup>2</sup> HMA Intermediate Type A on  
200 mm compacted aggregate base #53
2. See General Notes on Standard  
Drawing 610-PRAP-04.
3. See Table on Standard Drawing  
610-PRAP-05 for computed values.
4. G.N. - See General Notes

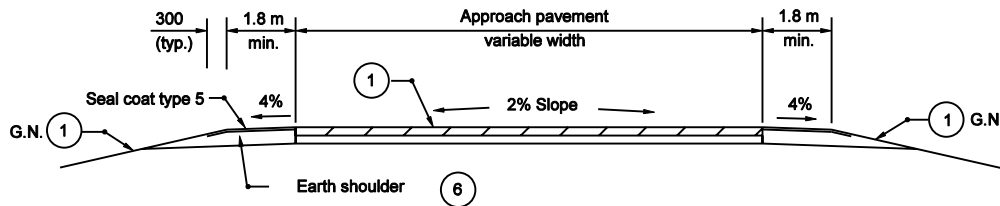

**SECTION A-A MINIMUM PAVEMENT SECTION**

For ADT ≤ 1000 ⑦

All Dimension are in mm unless otherwise specified

INDIANA DEPARTMENT OF TRANSPORTATION

**PUBLIC ROAD APPROACH  
TYPE A**

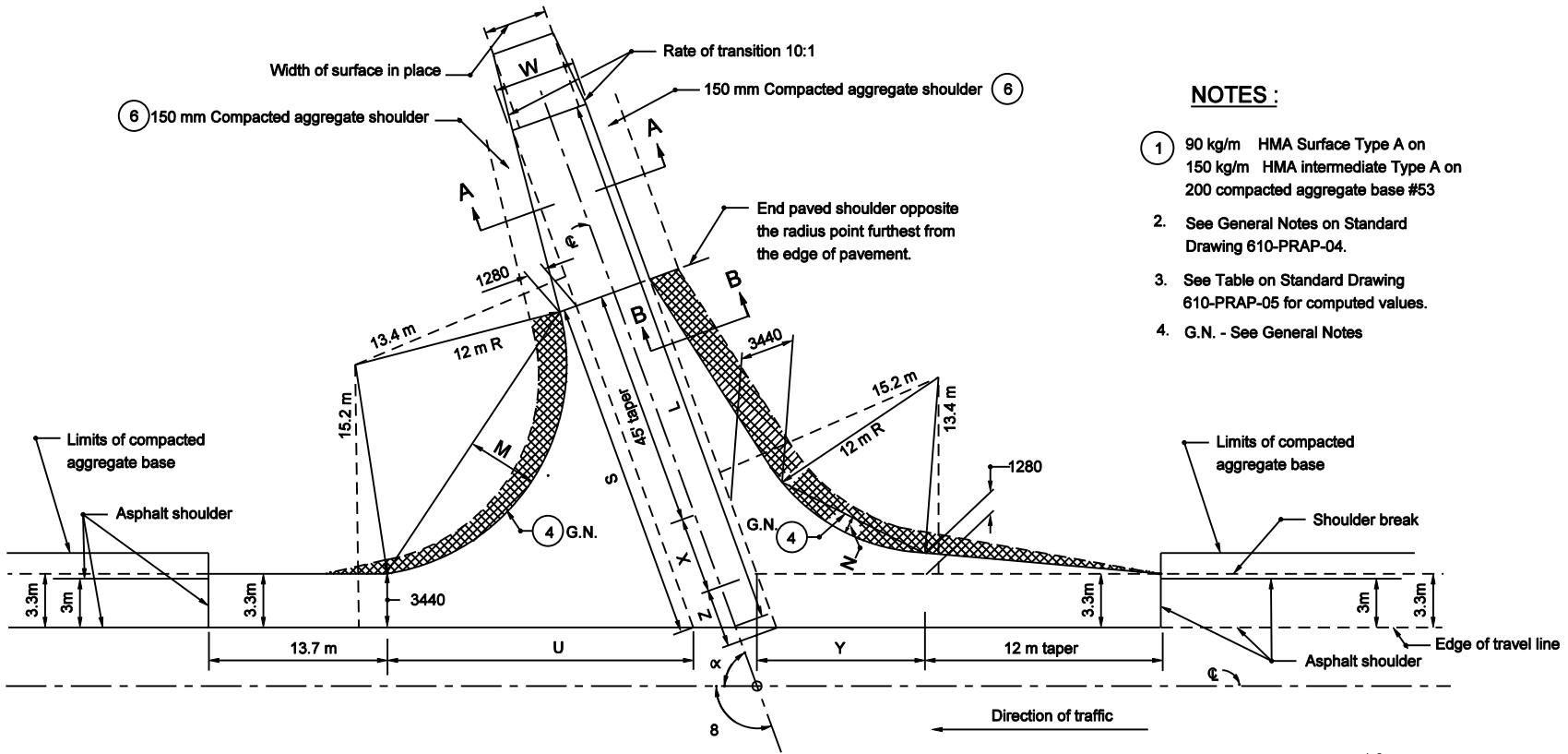

**NOTES :**

- 1 90 kg/m HMA Surface Type A on 150 kg/m HMA intermediate Type A on 200 compacted aggregate base #53
2. See General Notes on Standard Drawing 610-PRAP-04.
3. See Table on Standard Drawing 610-PRAP-05 for computed values.
4. G.N. - See General Notes

**PUBLIC ROAD APPROACH TYPE "B"**

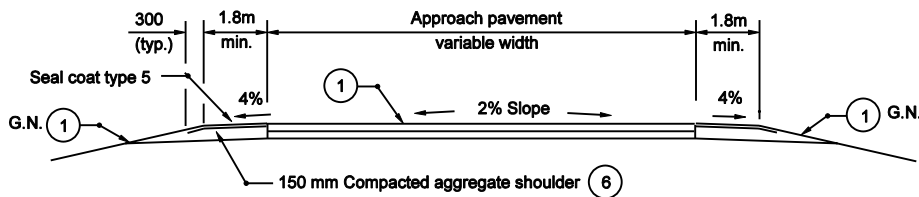
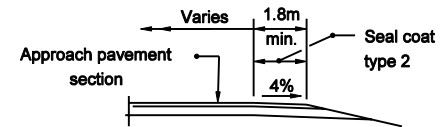

**SECTION A-A MINIMUM PAVEMENT SECTION**

For ADT  $\leq$  1000 (7)

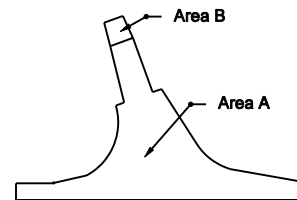

All Dimension are in mm unless otherwise specified  
 INDIANA DEPARTMENT OF TRANSPORTATION  
**PUBLIC ROAD APPROACH TYPE B**



EXAMPLE FOR TYPE D, W = 7.2 m  
 Intersection control angle  $\delta = 100^\circ$   
 L = 33.90 m  
 S = 16.32 m  
 U = 16.08 m  
 X = 10.17 m  
 Y = 10.95 m  
 V = 7.43 m  
 Total area = 649.81 m  
 (Area excludes partial auxiliary lane)

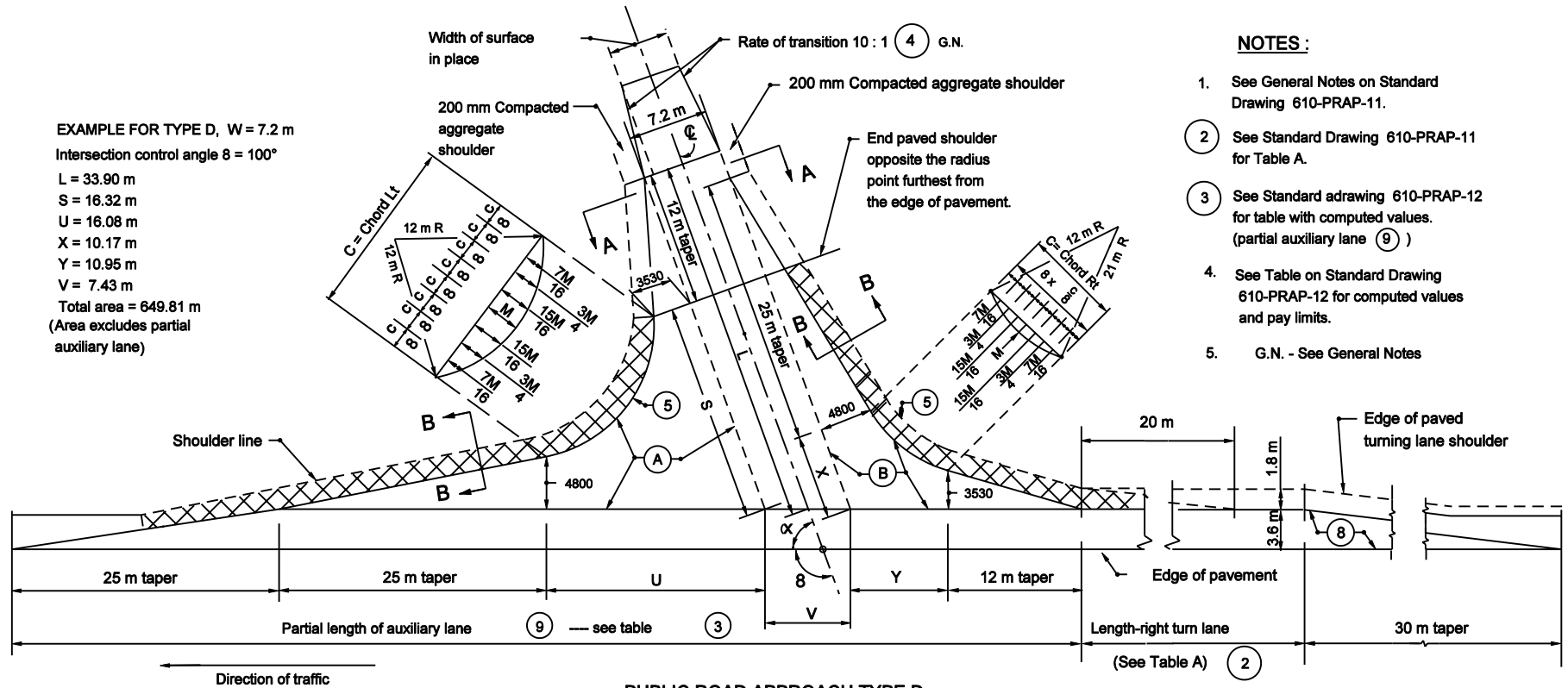

**NOTES :**

1. See General Notes on Standard Drawing 610-PRAP-11.
2. See Standard Drawing 610-PRAP-11 for Table A.
3. See Standard drawing 610-PRAP-12 for table with computed values. (partial auxiliary lane (9) )
4. See Table on Standard Drawing 610-PRAP-12 for computed values and pay limits.
5. G.N. - See General Notes

**PUBLIC ROAD APPROACH TYPE D**

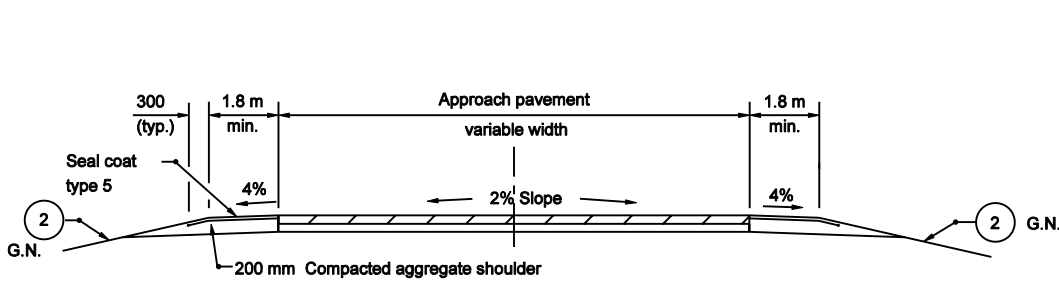

**SECTION A-A MINIMUM PAVEMENT SECTION**

FOR  $\leq 50$ : 50 TRUCKS, CLASS V OR ABOVE, TRUCKS PER DAY

90 kg/m HMA Surface Type A on  
 270 kg/m HMA Intermediate Type A on  
 200 mm compacted aggregate base #53

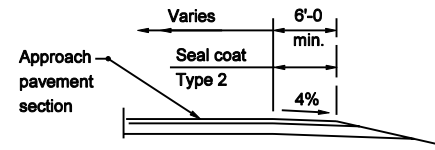

**SECTION B-B**

All Dimension are in mm unless otherwise specified

INDIANA DEPARTMENT OF TRANSPORTATION

**PUBLIC ROAD APPROACH  
 TYPE D**

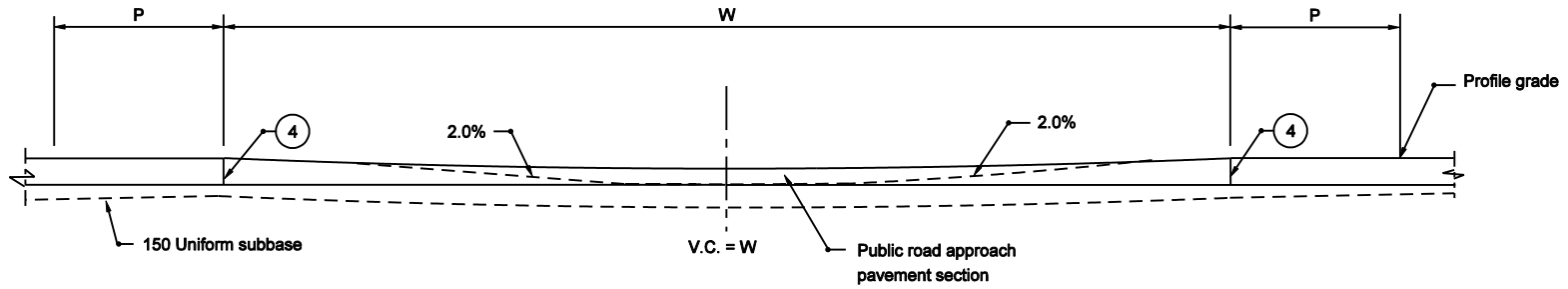

**SECTION A-A**

**LEGEND**

- ③ Construction joint type D-1. See Standard Drawing 503-CCPJ-01 for details.
  - ④ Longitudinal keyway joint, if pavement is PCCP. See Standard Drawing 503-CCPJ-04 for details.
  - ⑧ Longitudinal contraction joint. See Standard Drawings 503-CCPJ-07 AND -08 for details.
  - ⑨ 25 mm preformed joint filler
  - ⑩ Ear construction type A. See Standard Drawing 605-ERCN-01 for details.
  - ⑪ Ear construction type B. See Standard Drawing 605-ERCN-02 for details.
  - ⑭ Integral concrete curb
- L = Minimum longitudinal length of crossover  
P = Travel lane or turn lane width  
W = Width of median  
V.C. = Vertical curve length
-  = Stabilized shoulder

**GENERAL NOTES :**

1. The crossover length L is based on a 90° road intersection.
2. PCCP crossover shall be constructed if the cross road approach is concrete HMA crossover shall be constructed if the cross road approach asphalt.
3. See Standard Drawings 610-PRCO-01A through -07 for crossover plans.

All Dimension are in mm unless otherwise specified

INDIANA DEPARTMENT OF TRANSPORTATION  
**PUBLIC ROAD CROSSOVER  
SECTION**

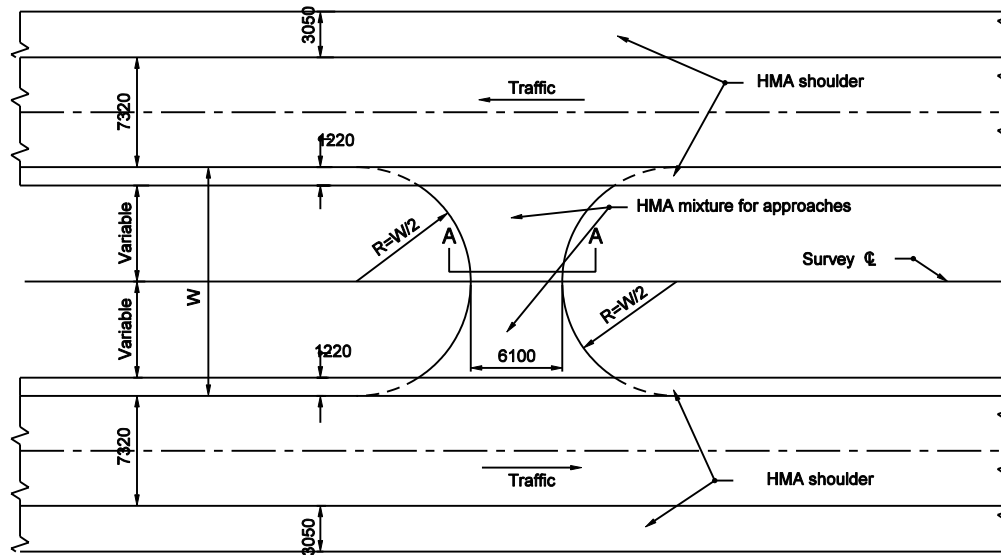

**U-TURN MEDIAN OPENING**

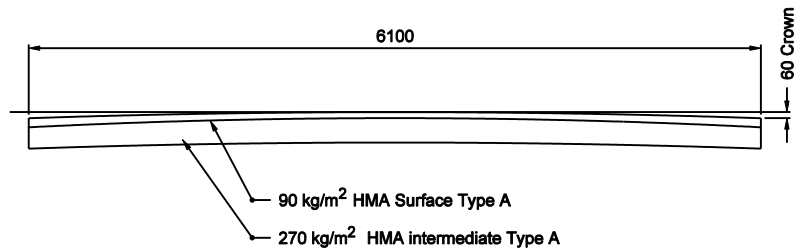

**SECTION A-A**

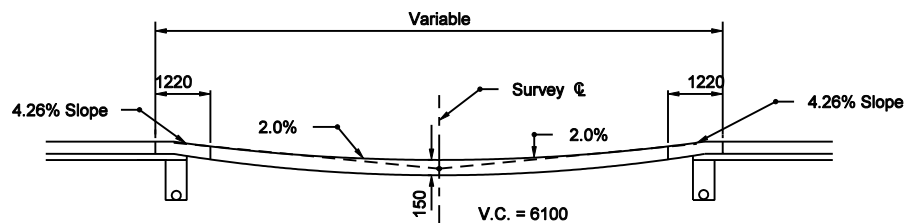

**GRADE OF U-TURN MEDIAN OPENING**

All Dimension are in mm unless otherwise specified  
INDIANA DEPARTMENT OF TRANSPORTATION  
**U-TURN MEDIAN OPENING**