



Indiana Department of Environmental Management Office of Water Quality Wetlands Section

Publication Date:
March 26, 2024

Closing Date:
April 16, 2024

IDEM ID Number:
2024-239-45-MTM-A

Corps of Engineers ID Number:

PUBLIC NOTICE

To all interested parties:

This letter shall serve as a formal notice of the receipt of an application for **Section 401 Water Quality Certification** by the Indiana Department of Environmental Management (IDEM). The purpose of the notice is to inform the public of active applications submitted for water quality certification under Section 401 of the Clean Water Act (33 U.S.C. § 1341) and to solicit comments and information on any impacts to water quality related to the proposed project. IDEM will evaluate whether the project complies with Indiana's water quality standards as set forth at 327 IAC 2.

1. Applicant: U.S. Army Corps of Engineers
Chicago District
231 LaSalle St. Suite 1500
Chicago, IL 60604

2. Agent:

3. Project location: Michigan City Harbor
The attached breakwater at Michigan City Harbor, Latitude: 41.729076, Longitude: -86.911765
The detached breakwater at Michigan City Harbor, Latitude: 41.728209, Longitude: -86.915373

4. Affected waterbody: Lake Michigan

5. Project Description: The applicant proposes to repair the attached breakwater and detached breakwater of Michigan City Harbor by placing no more than 15 cy of grout, 700 tons of 2.5"-0.5" stone, and 5,750 tons of 16.5-27.5 ton stone within existing footprints. Some of the stone will go below the water line, however none is going on the lakebed. Stone will only be used to fill voids on the slopes of the existing breakwater. The existing east pier is damaged, including significant voids in the timber crib structure risking damage to the lighthouse and pier itself. Steel sheet pile will encapsulate the end of the pier, voids in the timber crib will be filled, and the concrete cap will be replaced. To complete the work, the existing armor stone will be temporarily moved from approximately 30 feet of the east pier, starting at the northernmost end. Once the sheet pile has been installed, the armor stone will be reset. All armor stone will be placed within the existing footprint of the structure.

Comment period: Any person or entity who wishes to submit comments or information relevant to the aforementioned project may do so by the closing date noted above. Only comments or information related to water quality or potential impacts of the project on water quality can be considered by IDEM in the water quality certification review process.

Public Hearing: Any person may submit a written request that a public hearing be held to consider issues related to water quality in connection with the project detailed in this notice. The request for a hearing should be submitted within the comment period to be considered timely. The request should also state the reason for the public hearing as specifically as possible to assist IDEM in determining whether a public hearing is warranted.

Questions?

Additional information may be obtained from Marty Maupin, Project Manager, by phone at 317-233-2471 or by e-mail at mmaupin@idem.in.gov. Please address all correspondence to the project manager and reference the IDEM project identification number listed on this notice. Indicate if you wish to receive a copy of IDEM's final decision. Written comments and inquiries may be forwarded to -

Indiana Department of Environmental Management
100 North Senate Avenue
MC65-42 WQS IGCN 1255
Indianapolis, Indiana 46204-2251 FAX: 317/232-8406

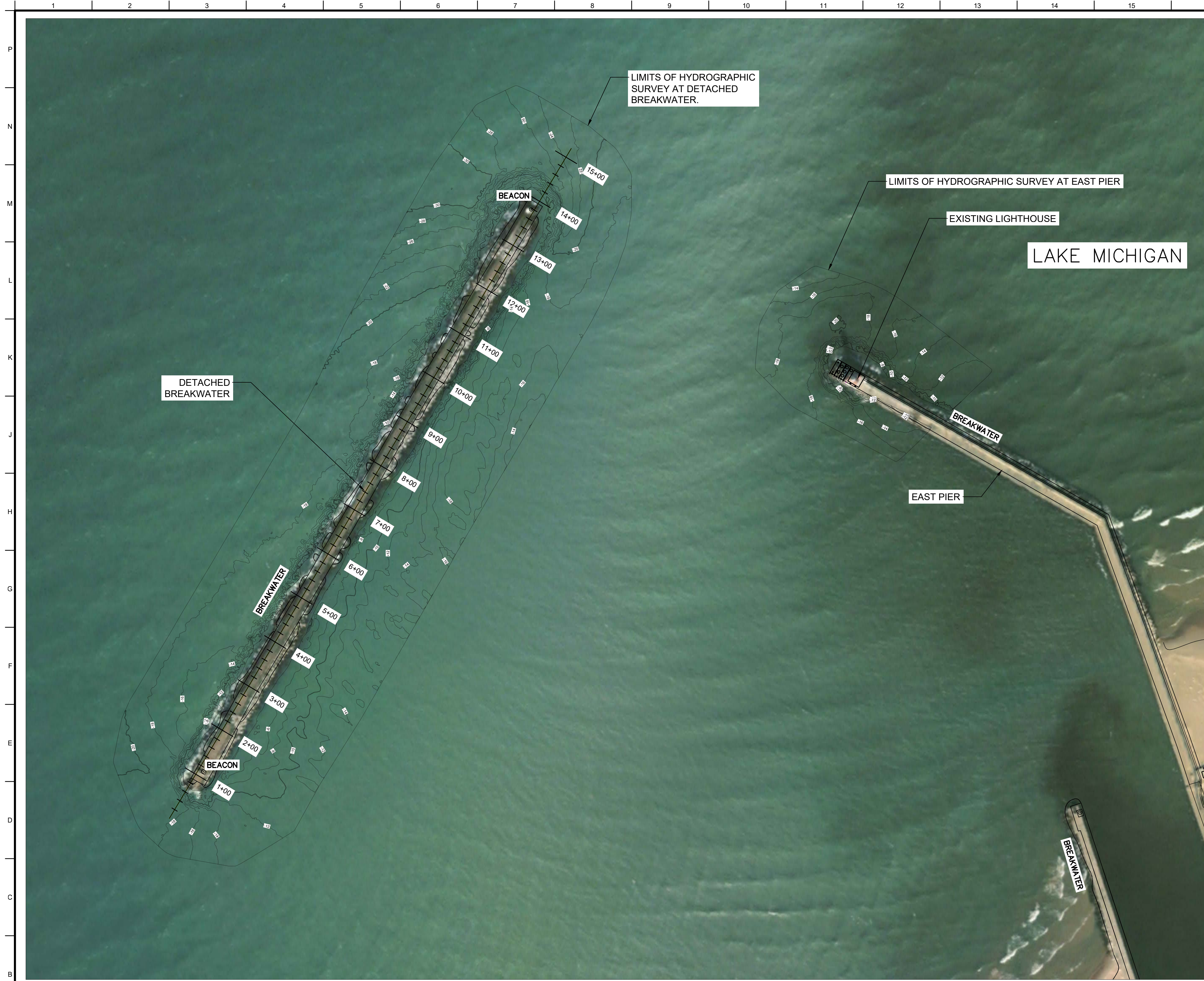

NOTES

1. HYDROGRAPHIC SURVEY CONDUCTED ON AUGUST 16, 2022 BY PRAIRIE ENGINEERS, P.C. ABOVE-WATER AND LAND TOPOGRAPHIC SURVEY WAS NOT CONDUCTED AS PART OF THE SCOPE OF WORK. ELEVATIONS OF ABOVE-WATER FEATURES (FOR EXAMPLE, ARMOR STONE ADJACENT TO THE EAST PIER AND DETACHED BREAKWATER, ABOVE-WATER CONCRETE SURFACES, ETC.) WILL NEED TO BE FIELD VERIFIED BY THE CONTRACTOR PRIOR TO CONSTRUCTION.
2. SURVEY HORIZONTAL DATUM AND COORDINATE SYSTEM: NAD83 INDIANA STATE PLANE-WEST, U.S. SURVEY FEET.
3. SURVEY VERTICAL DATUM: NAVD88, U.S. SURVEY FEET.
4. CONTOUR INTERVAL = 2', UNLESS NOTED OTHERWISE.
5. CONTOUR ELEVATIONS SHOWN ON THIS SHEET ARE REFERENCED TO LOW WATER DATUM (LWD) TO MATCH DESIGN REPAIR SECTION ELEVATIONS SHOWN ON C-501. FOR REFERENCE, 0.0' (LWD) = 577.5' (IGLD85) = 578.03' (NAVD88).
6. AERIAL PHOTO PROVIDED BY USACE. DATE OF PHOTOGRAPHY NOT KNOWN AND MAY NOT REPRESENT CURRENT CONDITIONS (FIELD VERIFY).

A1 EAST PIER AND DETACHED BREAKWATER HYDROGRAPHIC SURVEY
SCALE: 1" = 100'

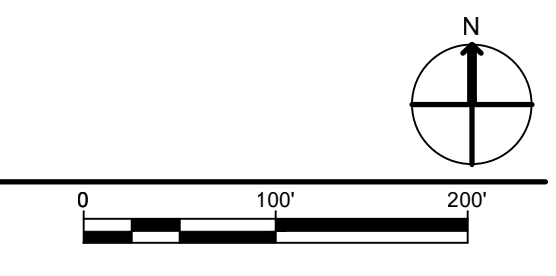

JUSTIN HINCE
 REGISTERED PROFESSIONAL ENGINEER
 STATE OF INDIANA
 No. 12300067

Justin Hince 07/14/2023

DESIGNED BY: S. CRETEN		ISSUE DATE: JULY 14, 2023
DRAWN BY: N. BORN		
CHECKED BY: S. CRETEN		SOLICITATION NO. : W912P623-B-0007
SUBMITTED BY: P. HINCK		CONTRACT NO. : W912P623-C-XXXX
ANSI D	SIZE:	

U.S. ARMY CORPS OF ENGINEERS
 CHICAGO DISTRICT
 231 S. LASALLE ST. SUITE 1600
 CHICAGO, ILLINOIS 60604

 318 E 101st Street, Suite 400, Chicago, IL 60618

MICHIGAN CITY
 EAST PIER AND DETACHED BREAKWATER REPAIR - FY23
 MICHIGAN CITY, INDIANA
 EAST PIER AND DETACHED BREAKWATER
 HYDROGRAPHIC SURVEY

SHEET ID
V-002

MARK	DESCRIPTION



1 2 3 4 5 6 7 8 9 10 11 12 13 14 15 16 17 18 19 20

P
N
M
L
K
J
H
G
F
E
D
C
B
A

A1 BORING LOCATION PLAN
SCALE: 1" = 50'

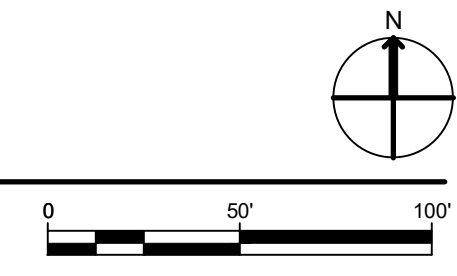

NOTES

- 1. SOIL BORINGS CONDUCTED ON 9/8/2022. SEE B-701 AND B-702 FOR BORING LOGS.

LEGEND

⊕ B-1 BORING LOCATION

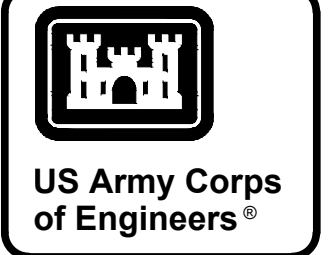

MARK	DESCRIPTION	DATE

DESIGNED BY: P. DEMSHAR	ISSUE DATE: JULY 14, 2023
DRAWN BY: N. BORN	SOLICITATION NO. : W912P623-B-0007
CHECKED BY: S. CRETEN	CONTRACT NO. : W912P623-C-XXXX
SUBMITTED BY: P. HINCK	ANSI D
U.S. ARMY CORPS OF ENGINEERS CHICAGO DISTRICT 231 S. LASALLE ST. SUITE 1600 CHICAGO, ILLINOIS 60604	BARR Prairie-Hanson State #10 Member/Provider IV

MICHIGAN CITY
EAST PIER AND DETACHED BREAKWATER REPAIR - FY23
MICHIGAN CITY, INDIANA

GEOTECHNICAL
BORING LOCATION PLAN

SHEET ID
B-101



Peter Demshar 7/14/2023

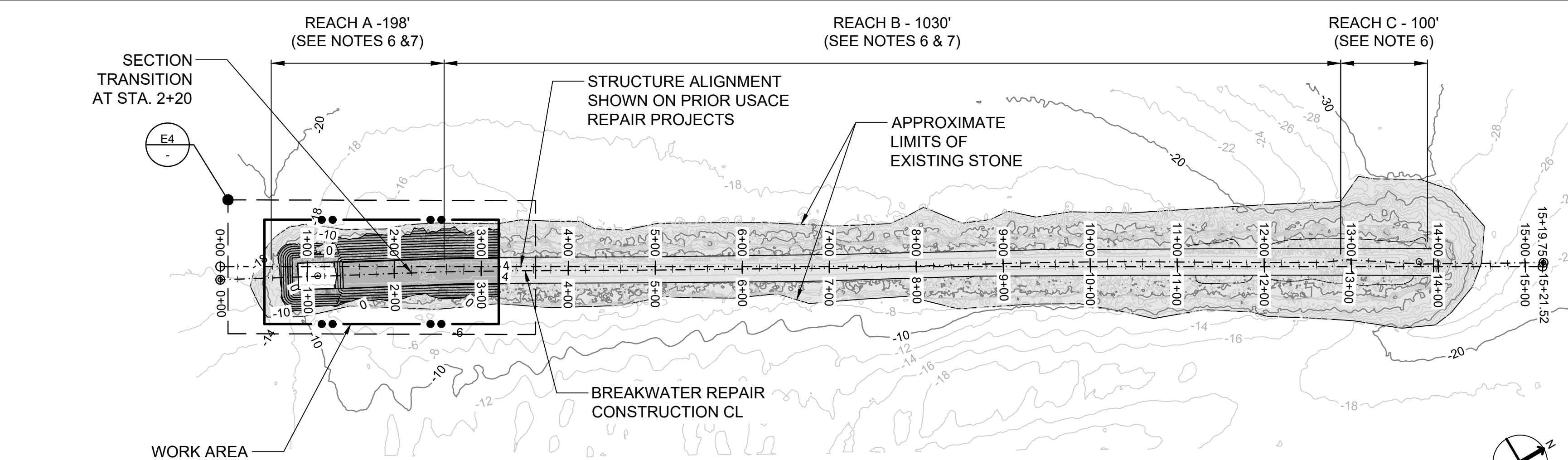

L4 DETACHED BREAKWATER PLAN VIEW
SCALE: 1" = 100'

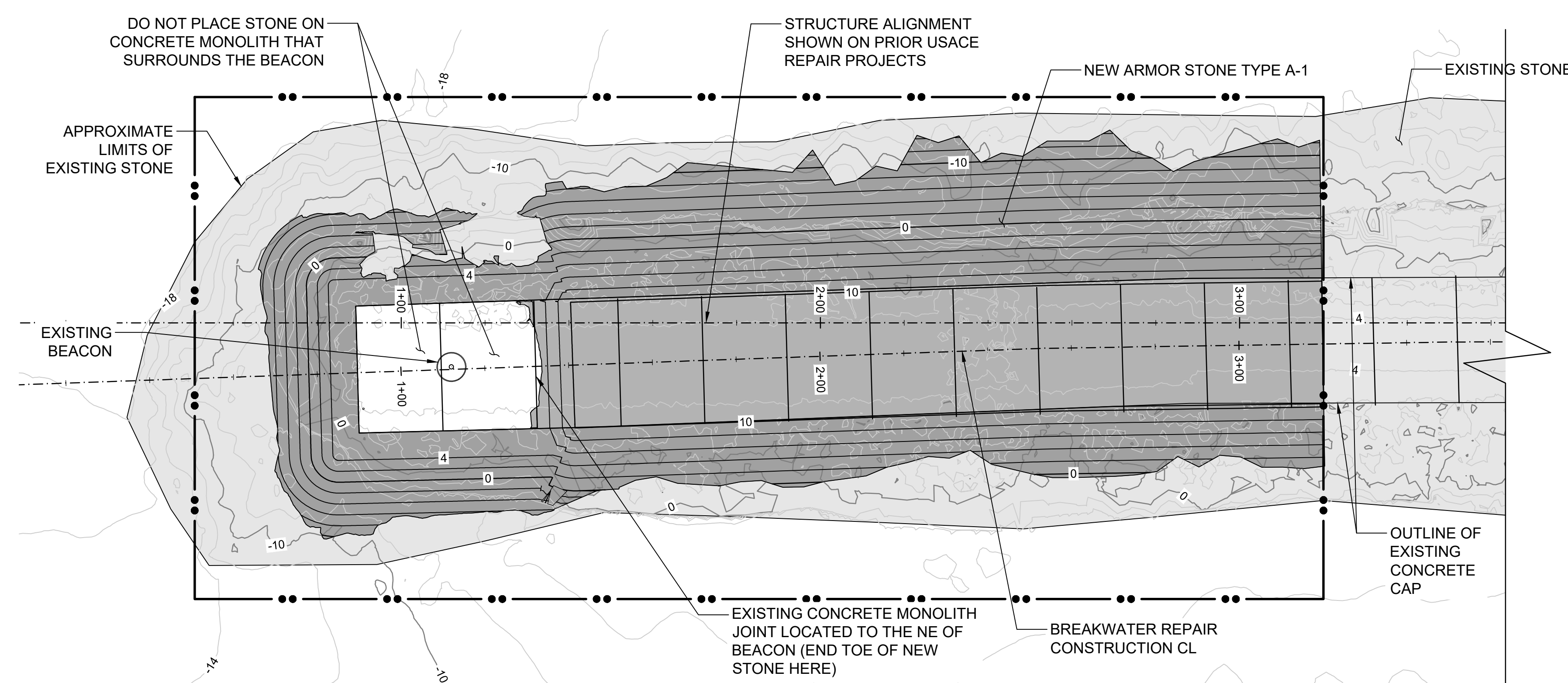

E4 DETAIL PLAN VIEW - DETACHED BREAKWATER REPAIRS
SCALE: 1" = 20'

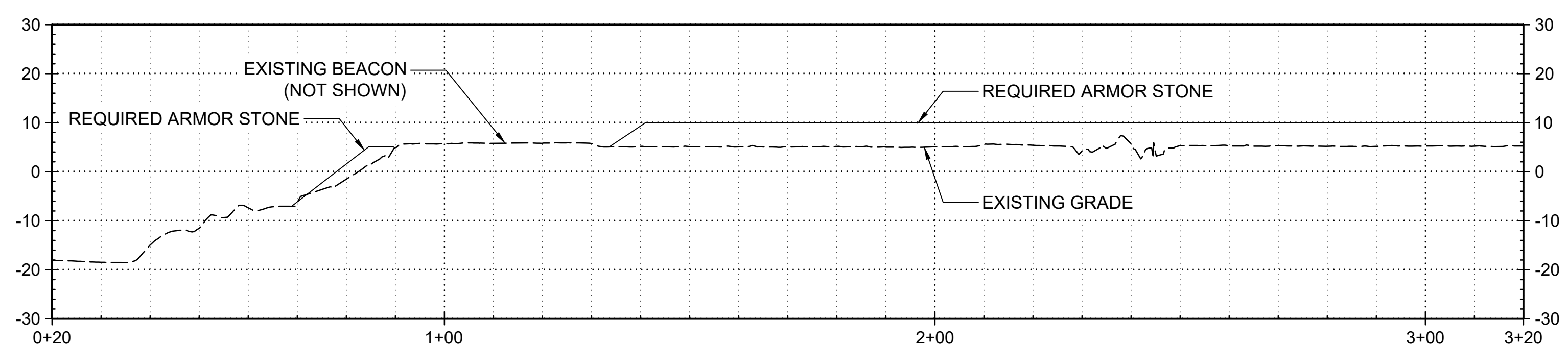

A4 DETACHED BREAKWATER PROFILE VIEW
SCALE 1" = 20'
PROFILE NOTE: PROFILE DRAWN ALONG BREAKWATER REPAIR CONSTRUCTION CONTROL CL.

- NOTES**
- REFER TO SHEETS C-301 THROUGH C-302 FOR CROSS SECTIONS OF THE BREAKWATER STONE PLACEMENT.
 - STATIONS 0+70 THROUGH 2+20 SHALL MATCH REPAIRED SECTION A AND STATIONS 2+20 THROUGH 3+20 SHALL MATCH REPAIRED SECTION B, SEE SHEET C-501.
 - CONTRACTOR SHALL REMOVE OR REPOSITION EXISTING STONES TO ENSURE NEW STONE OVERLAY INTERLOCKS WELL WITH THE EXISTING STONE AND REPAIRED CROSS SECTION IS ACHIEVED.
 - ALL DEBRIS IS TO BE REMOVED FROM BREAKWATER PRIOR TO PLACING NEW STONE.
 - CONTOUR ELEVATIONS SHOWN ON THIS SHEET ARE REFERENCED TO LOW WATER DATUM (LWD) TO MATCH DESIGN REPAIR SECTION ELEVATIONS SHOWN ON C-501. FOR REFERENCE, 0.0' (LWD) = 577.5' (IGLD85) = 578.03' (NAVD88).
 - REFER TO R-001 FOR DETACHED BREAKWATER ORIGINAL DESIGN SECTIONS.
 - REFER TO C-501 FOR DETACHED BREAKWATER DESIGN REPAIR SECTIONS.
 - AERIAL PHOTO PROVIDED BY USACE. DATE OF PHOTOGRAPHY NOT KNOWN AND MAY NOT REPRESENT CURRENT CONDITIONS (FIELD VERIFY).
- LEGEND**
- NEW STONE PLACEMENT
 - EXISTING ARMOR STONE

BREAKWATER REPAIR CONSTRUCTION CL

STATION	NORTHING	EASTING
0+00	2,359,800.15	2,998,286.50
2+53.12	2,360,021.68	2,998,408.97
3+50.68	2,360,106.09	2,998,457.86
4+00.37	2,360,148.78	2,998,483.32
5+00.02	2,360,234.46	2,998,534.19
6+42.08	2,360,357.11	2,998,605.85
7+26.45	2,360,429.64	2,998,648.97
7+93.47	2,360,488.24	2,998,681.49
9+34.12	2,360,610.94	2,998,750.24
10+35.19	2,360,698.24	2,998,801.18
11+94.35	2,360,834.08	2,998,884.12
12+68.54	2,360,897.90	2,998,921.94
12+95.99	2,360,922.79	2,998,933.53
13+79.91	2,360,992.15	2,998,980.78
15+21.52	2,361,114.29	2,999,052.42

- TABLE NOTE**
- COORDINATES SHOWN ABOVE FOR "BREAKWATER REPAIR CONSTRUCTION CL" ARE PROVIDED FOR GENERAL REFERENCE ONLY. DESIGN INTENT IS TO CONSTRUCT THE REPAIRED RUBBLEMOUND SECTIONS AS SHOWN ON C-501 CENTERED ON THE EXISTING STRUCTURE. CONTRACTOR SHALL FIELD VERIFY CONSTRUCTION CL AND FIELD FIT AS REQUIRED TO MEET DESIGN INTENT.

STRUCTURE ALIGNMENT SHOWN ON PRIOR USACE REPAIR PROJECTS

STATION	NORTHING	EASTING
0+00	2,359,807.92	2,998,273.56
15+19.75	2,361,110.97	2,999,055.68

- TABLE NOTE**
- COORDINATES SHOWN ABOVE FOR "STRUCTURE ALIGNMENT SHOWN ON PRIOR USACE REPAIR PROJECTS" ARE PROVIDED FOR GENERAL REFERENCE ONLY. DESIGN INTENT IS TO CONSTRUCT THE REPAIRED RUBBLEMOUND SECTIONS AS SHOWN ON C-501 CENTERED ON THE EXISTING STRUCTURE. CONTRACTOR SHALL FIELD VERIFY CONSTRUCTION CL AND FIELD FIT AS REQUIRED TO MEET DESIGN INTENT.

US Army Corps of Engineers®

DATE: _____

DESCRIPTION: _____

MARK: _____

BARR

U.S. ARMY CORPS OF ENGINEERS
CHICAGO DISTRICT
231 S. LASALLE ST., SUITE 1500
CHICAGO, ILLINOIS 60604

ISSUE DATE: JULY 14, 2023
SOLICITATION NO.: W912P623-B-0007
CONTRACT NO.: W912P623-C-XXXX

DESIGNED BY: S. CRETEN
DRAWN BY: N. BORN
CHECKED BY: S. CRETEN
SUBMITTED BY: P. HINCK

Prairie-Hanson
SINCE 1910 Member Since 1994

MICHIGAN CITY
EAST PIER AND DETACHED BREAKWATER REPAIR - FY23
MICHIGAN CITY, INDIANA

DETACHED BREAKWATER PLAN VIEW

SHEET ID
C-102



07/14/2023

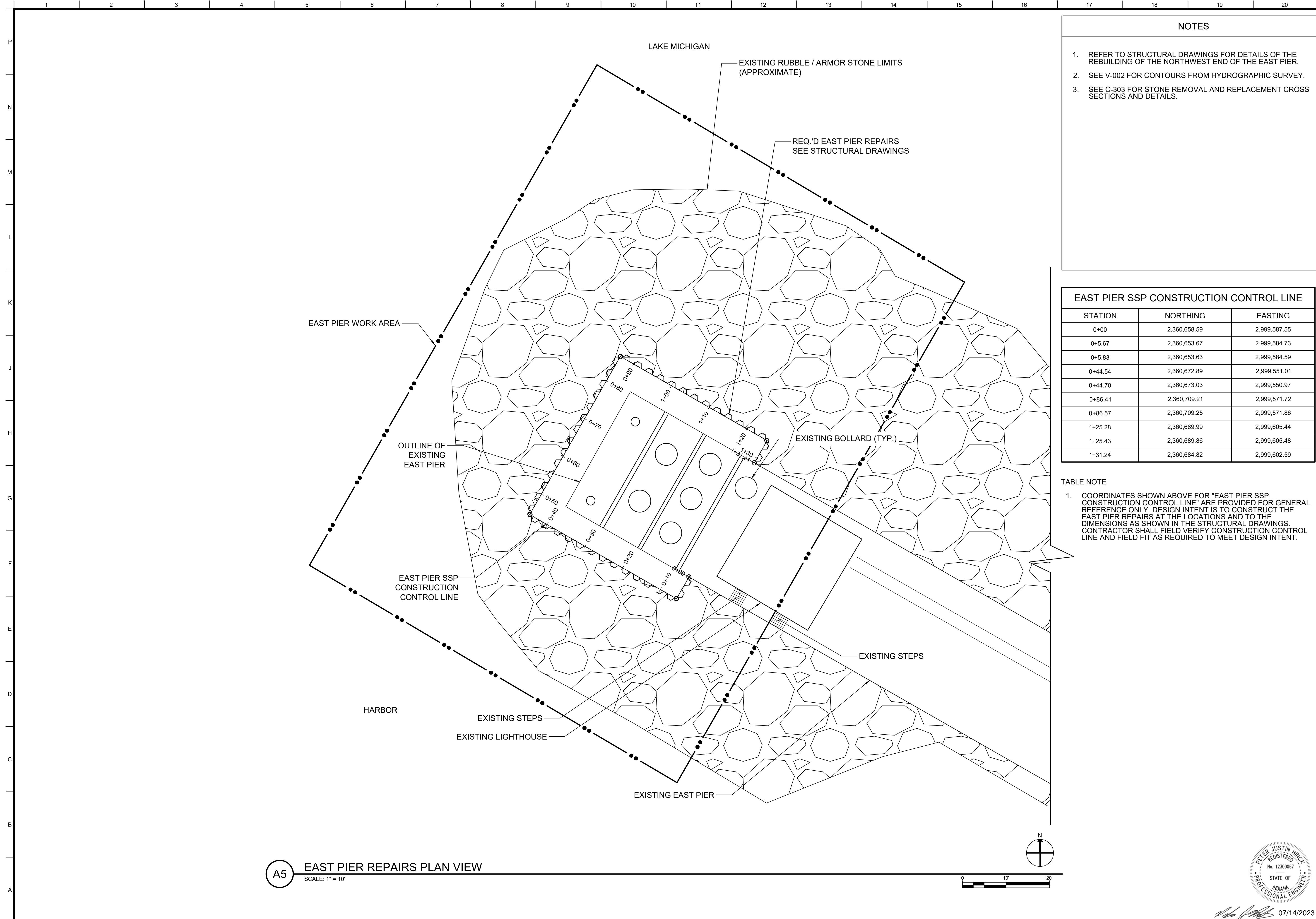

NOTES

- REFER TO STRUCTURAL DRAWINGS FOR DETAILS OF THE REBUILDING OF THE NORTHWEST END OF THE EAST PIER.
- SEE V-002 FOR CONTOURS FROM HYDROGRAPHIC SURVEY.
- SEE C-303 FOR STONE REMOVAL AND REPLACEMENT CROSS SECTIONS AND DETAILS.

EAST PIER SSP CONSTRUCTION CONTROL LINE		
STATION	NORTHING	EASTING
0+00	2,360,658.59	2,999,587.55
0+5.67	2,360,653.67	2,999,584.73
0+5.83	2,360,653.63	2,999,584.59
0+44.54	2,360,672.89	2,999,551.01
0+44.70	2,360,673.03	2,999,550.97
0+86.41	2,360,709.21	2,999,571.72
0+86.57	2,360,709.25	2,999,571.86
1+25.28	2,360,689.99	2,999,605.44
1+25.43	2,360,689.86	2,999,605.48
1+31.24	2,360,684.82	2,999,602.59

TABLE NOTE

- COORDINATES SHOWN ABOVE FOR "EAST PIER SSP CONSTRUCTION CONTROL LINE" ARE PROVIDED FOR GENERAL REFERENCE ONLY. DESIGN INTENT IS TO CONSTRUCT THE EAST PIER REPAIRS AT THE LOCATIONS AND TO THE DIMENSIONS AS SHOWN IN THE STRUCTURAL DRAWINGS. CONTRACTOR SHALL FIELD VERIFY CONSTRUCTION CONTROL LINE AND FIELD FIT AS REQUIRED TO MEET DESIGN INTENT.

A5 EAST PIER REPAIRS PLAN VIEW
SCALE: 1" = 10'

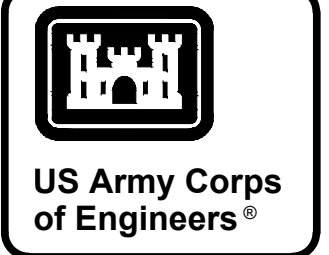
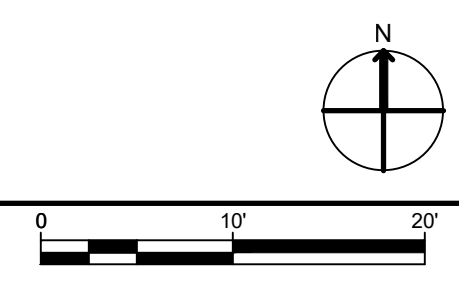

DATE	DESCRIPTION	MARK

DESIGNED BY: S. CRETEN	ISSUE DATE: JULY 14, 2023
DRAWN BY: N. BORN	SOLICITATION NO.: W912P623-B-0007
CHECKED BY: S. CRETEN	CONTRACT NO.: W912P623-C-XXXX
SUBMITTED BY: P. HINCK	ANSI D

U.S. ARMY CORPS OF ENGINEERS
CHICAGO DISTRICT
231 S. LASALLE ST. SUITE 1900
CHICAGO, ILLINOIS 60604

MICHIGAN CITY
EAST PIER AND DETACHED BREAKWATER REPAIR - FY23
MICHIGAN CITY, INDIANA

EAST PIER REPAIRS PLAN VIEW



SHEET ID
C-103

07/14/2023

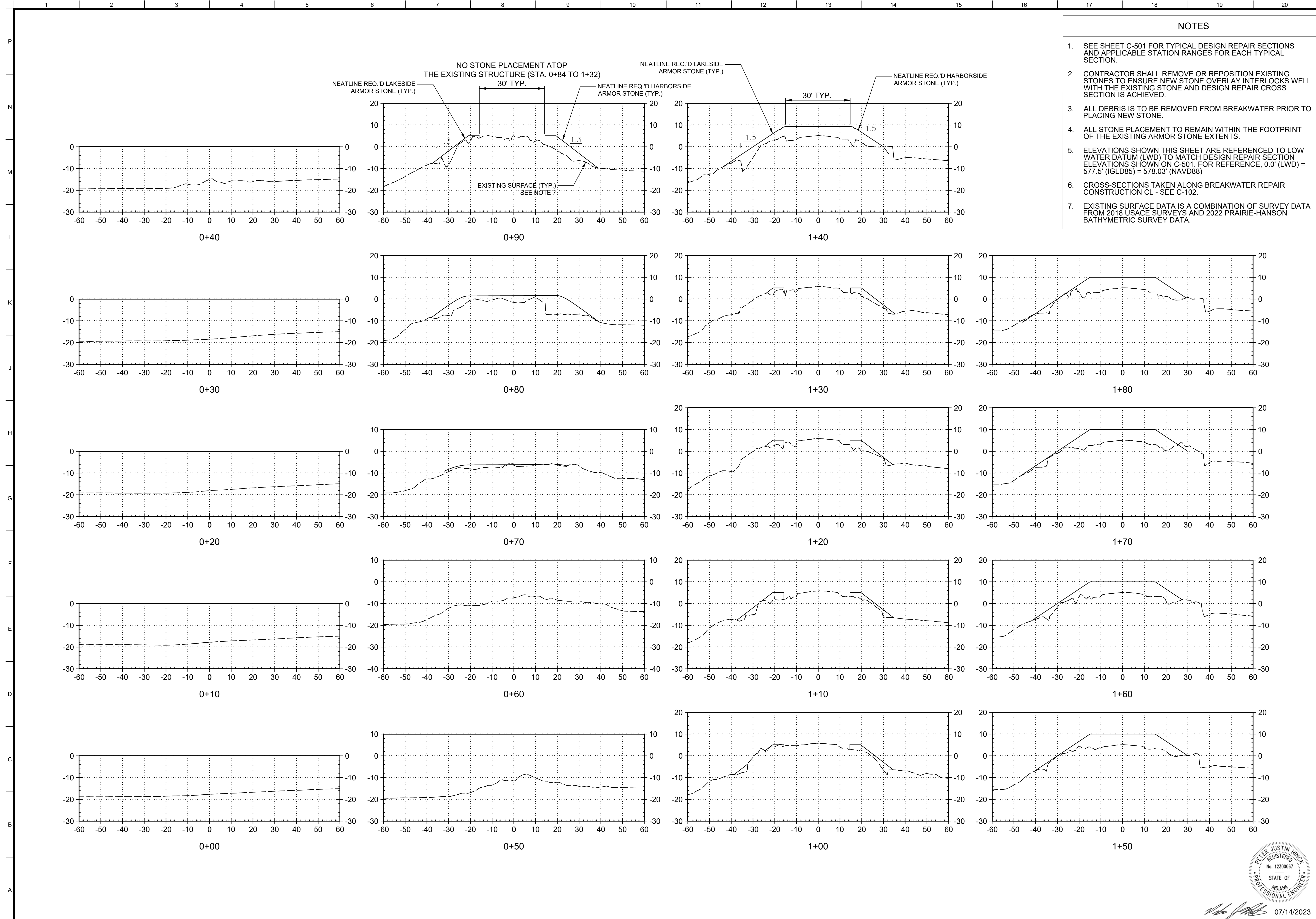

NOTES

- SEE SHEET C-501 FOR TYPICAL DESIGN REPAIR SECTIONS AND APPLICABLE STATION RANGES FOR EACH TYPICAL SECTION.
- CONTRACTOR SHALL REMOVE OR REPOSITION EXISTING STONES TO ENSURE NEW STONE OVERLAY INTERLOCKS WELL WITH THE EXISTING STONE AND DESIGN REPAIR CROSS SECTION IS ACHIEVED.
- ALL DEBRIS IS TO BE REMOVED FROM BREAKWATER PRIOR TO PLACING NEW STONE.
- ALL STONE PLACEMENT TO REMAIN WITHIN THE FOOTPRINT OF THE EXISTING ARMOR STONE EXTENTS.
- ELEVATIONS SHOWN THIS SHEET ARE REFERENCED TO LOW WATER DATUM (LWD) TO MATCH DESIGN REPAIR SECTION ELEVATIONS SHOWN ON C-501. FOR REFERENCE, 0.0' (LWD) = 577.5' (IGLD85) = 578.03' (NAVD88)
- CROSS-SECTIONS TAKEN ALONG BREAKWATER REPAIR CONSTRUCTION CL - SEE C-102.
- EXISTING SURFACE DATA IS A COMBINATION OF SURVEY DATA FROM 2018 USACE SURVEYS AND 2022 PRAIRIE-HANSON BATHYMETRIC SURVEY DATA.

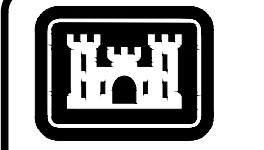

US Army Corps of Engineers®

MARK	DESCRIPTION	DATE

DESIGNED BY: S. CRETEN	ISSUE DATE: JULY 14, 2023
DRAWN BY: N. BORN	SOLICITATION NO.: W912P623-B-0007
CHECKED BY: S. CRETEN	CONTRACT NO.: W912P623-C-XXXX
SUBMITTED BY: P. HINCK	ANSI D SIZE

U.S. ARMY CORPS OF ENGINEERS
CHICAGO DISTRICT
231 S. LASALLE ST. SUITE 1600
CHICAGO, ILLINOIS 60604

MICHIGAN CITY
EAST PIER AND DETACHED BREAKWATER REPAIR - FY23
MICHIGAN CITY, INDIANA
DETACHED BREAKWATER CROSS-SECTIONS

SHEET ID
C-301



[Signature] 07/14/2023

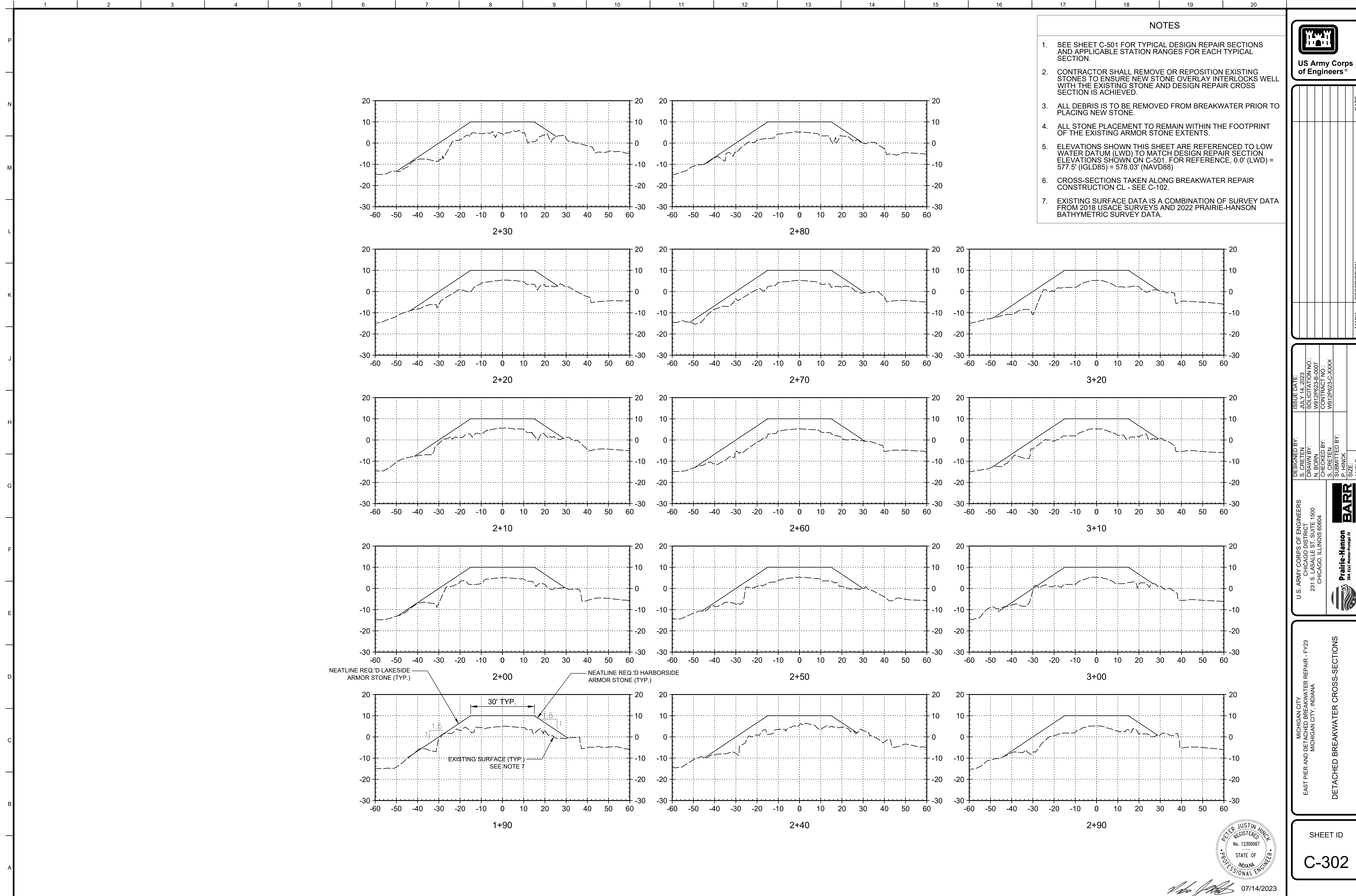

- NOTES**
1. SEE SHEET C-501 FOR TYPICAL DESIGN REPAIR SECTIONS AND APPLICABLE STATION RANGES FOR EACH TYPICAL SECTION.
 2. CONTRACTOR SHALL REMOVE OR REPOSITION EXISTING STONES TO ENSURE NEW STONE OVERLAY INTERLOCKS WELL WITH THE EXISTING STONE AND DESIGN REPAIR CROSS SECTION IS ACHIEVED.
 3. ALL DEBRIS IS TO BE REMOVED FROM BREAKWATER PRIOR TO PLACING NEW STONE.
 4. ALL STONE PLACEMENT TO REMAIN WITHIN THE FOOTPRINT OF THE EXISTING ARMOR STONE EXTENTS.
 5. ELEVATIONS SHOWN THIS SHEET ARE REFERENCED TO LOW WATER DATUM (LWD) TO MATCH DESIGN REPAIR SECTION ELEVATIONS SHOWN ON C-501. FOR REFERENCE, 0.0' (LWD) = 577.5' (IGLD85) = 578.03' (NAVD88)
 6. CROSS-SECTIONS TAKEN ALONG BREAKWATER REPAIR CONSTRUCTION CL - SEE C-102.
 7. EXISTING SURFACE DATA IS A COMBINATION OF SURVEY DATA FROM 2018 USACE SURVEYS AND 2022 PRAIRIE-HANSON BATHYMETRIC SURVEY DATA.

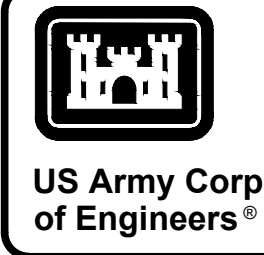

MARK	DESCRIPTION	DATE

DESIGNED BY: S. CRETEN	ISSUE DATE: JULY 14, 2023
DRAWN BY: N. BORN	SOLICITATION NO.: W912P623-B-0007
CHECKED BY: S. CRETEN	CONTRACT NO.: W912P623-C-XXXX
SUBMITTED BY: P. HINCK	ANSI D SIZE

U.S. ARMY CORPS OF ENGINEERS
CHICAGO DISTRICT
231 S. LASALLE ST. SUITE 1500
CHICAGO, ILLINOIS 60604

BARR
Prairie-Hanson
184-110 Member Perseus IV

MICHIGAN CITY
EAST PIER AND DETACHED BREAKWATER REPAIR - FY23
MICHIGAN CITY, INDIANA
DETACHED BREAKWATER CROSS-SECTIONS

SHEET ID
C-302



Justin Hink 07/14/2023

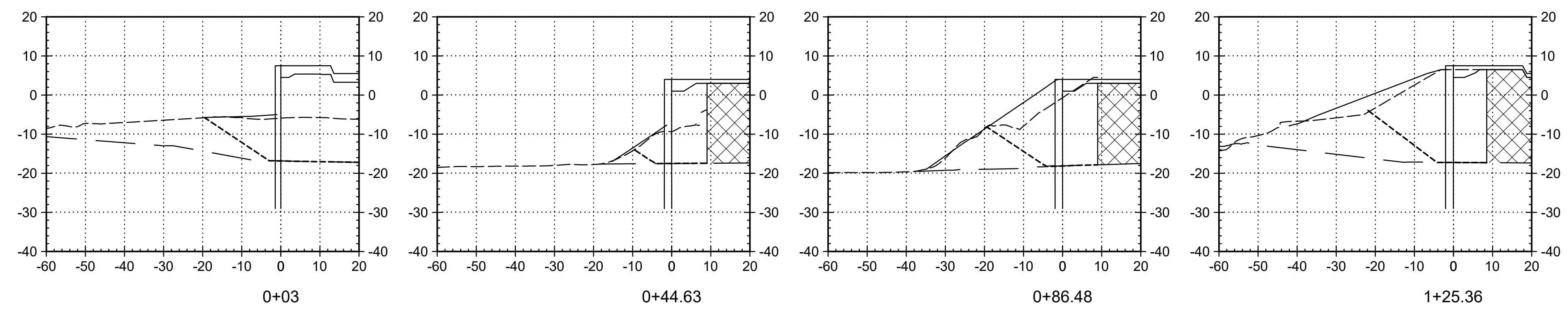
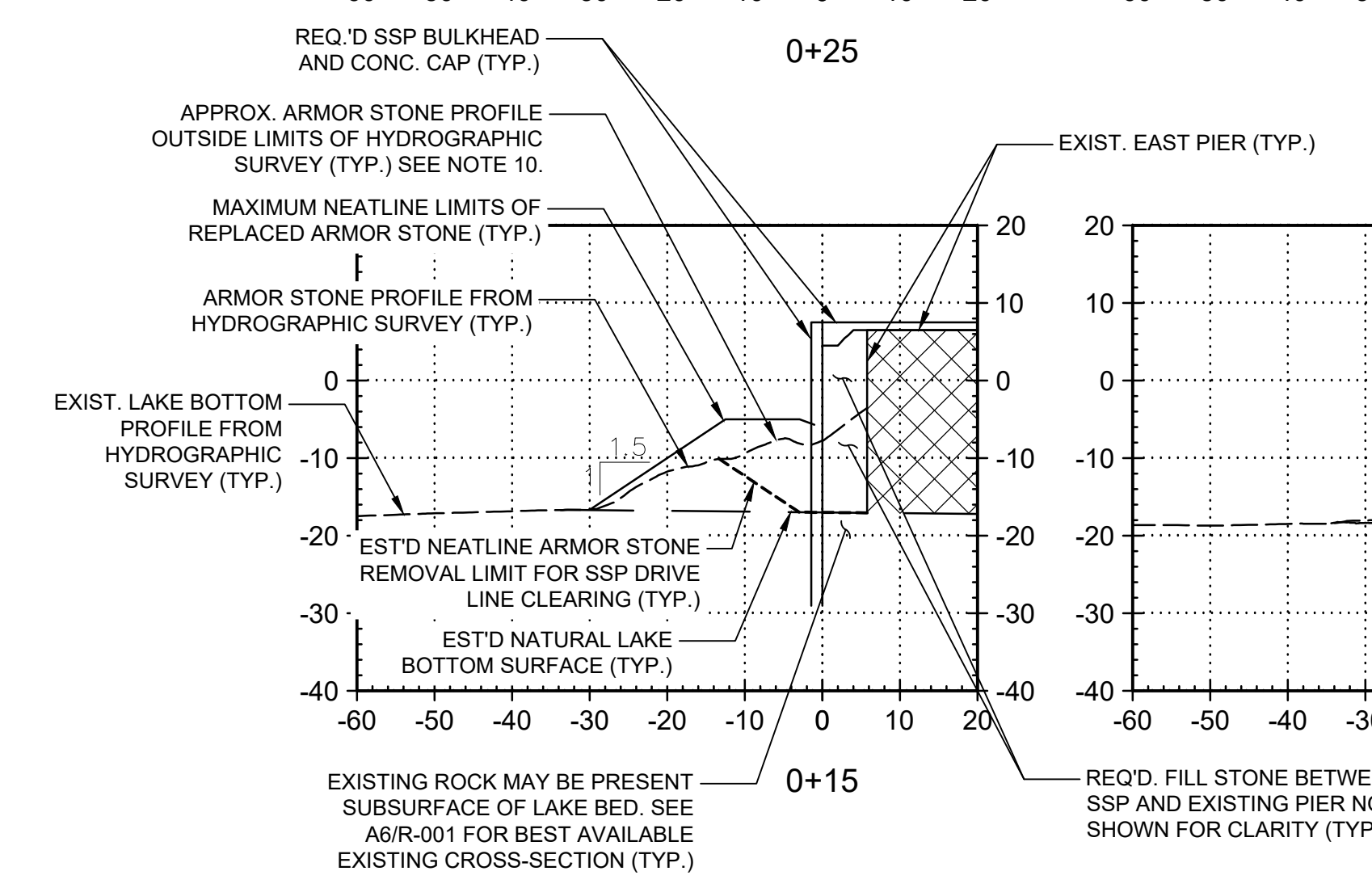
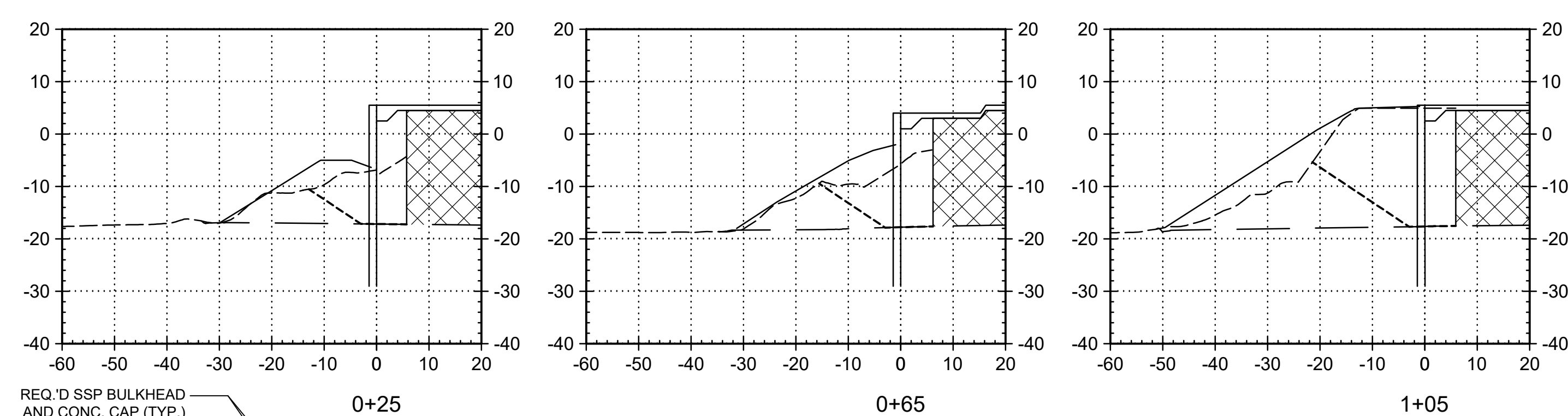
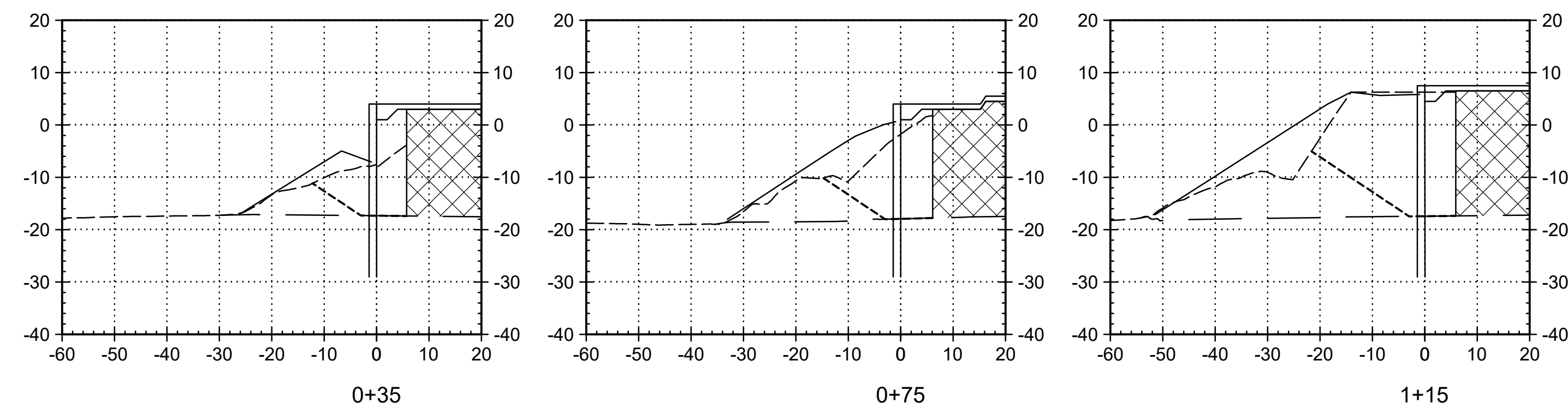

- ### NOTES
- SEE STRUCTURAL DRAWINGS FOR REQUIRED REPAIRS TO THE NW END OF THE EAST PIER, INCLUDING REQUIRED REPAIR SEQUENCING.
 - CONTRACTOR SHALL REMOVE EXISTING ARMOR STONE AS REQUIRED TO CLEAR SSP DRIVE LINE. LIMITS SHOWN ARE APPROXIMATE. FINAL LIMITS SHALL BE DETERMINED BY CONTRACTOR AS NEEDED TO INSTALL SSP PER CONTRACT REQUIREMENTS. NO MORE THAN 30' OF ARMOR STONE ALONG THE DRIVE LINE MAY BE REMOVED AT ONE TIME.
 - ARMOR STONE REMOVED SHALL NOT BE PLACED OR STOCKPILED ON THE LAKE BOTTOM OUTSIDE OF THE EXISTING FOOTPRINT AREA. CONTRACTOR RESPONSIBLE FOR DETERMINING ARMOR STONE REMOVAL MEANS, METHODS, AND TEMPORARY STAGING AREA(S).
 - STONE SHALL BE REPLACED WITHIN THE EXISTING STONE FOOTPRINT LIMITS AND SHALL BE PLACED NO STEEPER THAN 1.5H:1V. TOP OF STONE ELEVATIONS SHALL MATCH PRE-CONSTRUCTION ELEVATIONS AROUND THE PERIMETER OF THE PIER (ELEVATIONS VARY, SEE V-002 AND CROSS SECTIONS THIS SHEET.)
 - REPOSITION EXISTING STONE AS NEEDED TO ENSURE REPLACED STONE INTERLOCKS WELL WITH THE EXISTING STONE.
 - ALL DEBRIS SHALL BE REMOVED FROM PIER AND EXISTING STONE PRIOR TO REPLACING STONE.
 - IF EXCESS STONE REMAINS AFTER FILLING ALL VOIDS WITHIN THE ALLOWABLE PLACEMENT LIMITS, CONTRACTOR SHALL TRANSPORT AND DISPOSE OF THE EXCESS STONE AS PROVIDED IN THE SPECIFICATIONS OR AS DIRECTED BY THE CONTRACTING OFFICER.
 - ELEVATIONS SHOWN THIS SHEET ARE REFERENCED TO LOW WATER DATUM (LWD), FOR REFERENCE, 0.0' (LWD) = 577.5' (IGLD85) = 578.03' (NAVD88)
 - CROSS-SECTIONS TAKEN ALONG EAST PIER SSP CONSTRUCTION CONTROL LINE - SEE C-103.
 - HYDROGRAPHIC SURVEY CONDUCTED IN 2022 BY PRAIRIE-HANSON, TOPOGRAPHIC SURVEY OF PIER AND ARMOR STONE ADJACENT TO THE PIER WAS NOT IN THE SCOPE OF WORK AND WAS NOT CONDUCTED. CROSS SECTION DATA SHOWN OUTSIDE THE LIMITS OF THE HYDROGRAPHIC SURVEY IS BASED ON LIDAR DATA OBTAINED DURING THE SURVEY AND SHOULD BE CONSIDERED APPROXIMATE.

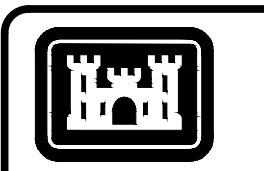

US Army Corps of Engineers

DATE	DESCRIPTION

DESIGNED BY: S. CRETEN	ISSUE DATE: JULY 14, 2023	DRAWN BY: N. BORN	SOLICITATION NO.: W912P623-B-0007
CHECKED BY: S. CRETEN	CONTRACT NO.: W912P623-C-XXXX	SUBMITTED BY: P. HINCK	ANSI D SIZE:

U.S. ARMY CORPS OF ENGINEERS
CHICAGO DISTRICT
231 S. LA SALLE ST. SUITE 1500
CHICAGO, ILLINOIS 60604



BARR
Prairie-Hanson
184 E. Wacker Drive, Suite 1100
Chicago, IL 60601

MICHIGAN CITY
EAST PIER AND DETACHED BREAKWATER REPAIR - FY23
MICHIGAN CITY, INDIANA

EAST PIER CROSS SECTIONS

SHEET ID
C-303



PETER JUSTIN HINCK
REGISTERED
No. 12300067
STATE OF
INDIANA
PROFESSIONAL ENGINEER

07/14/2023

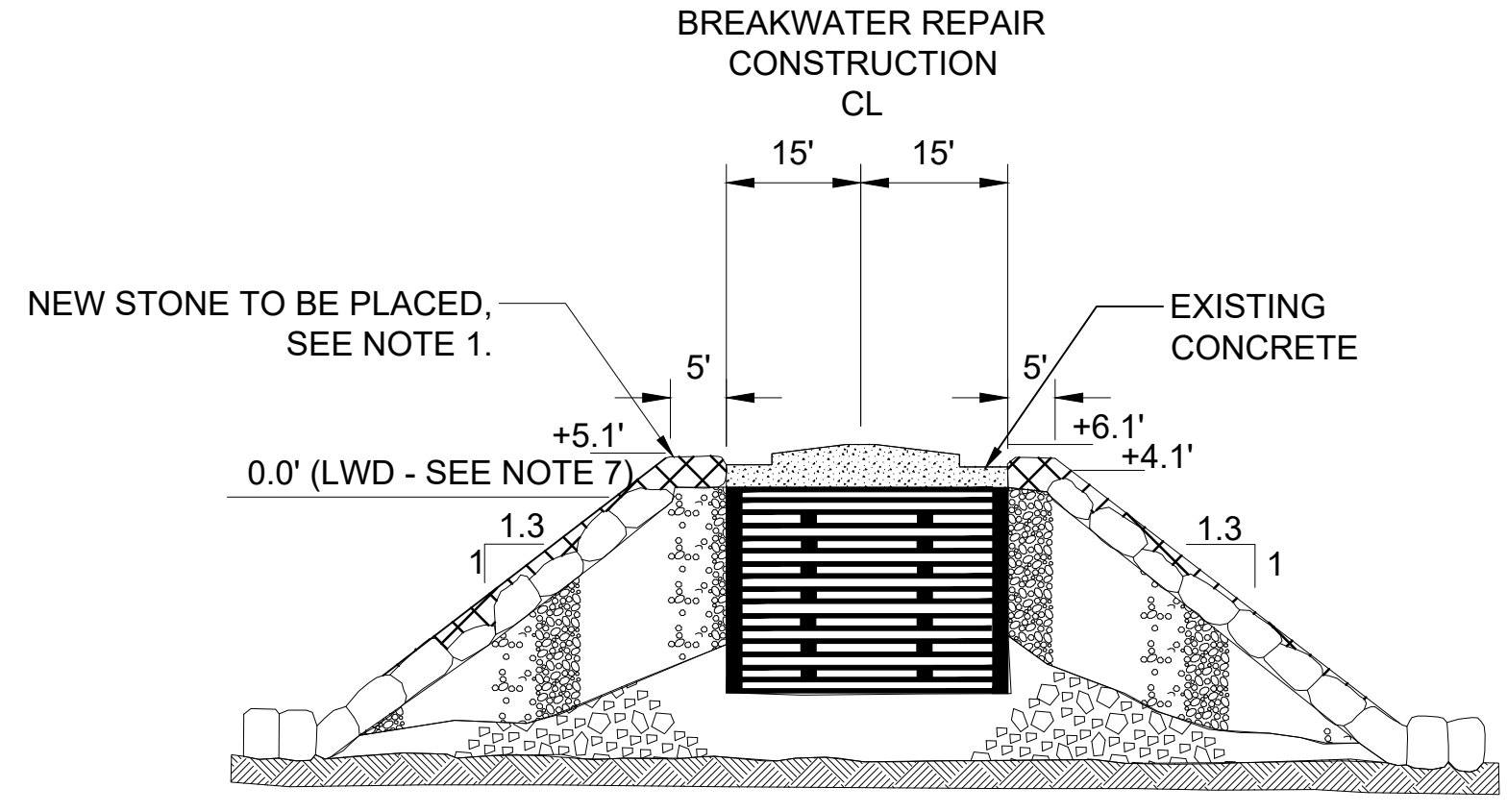

L9 REPAIRED DETACHED BREAKWATER REACH A (APPLIES STA. 0+70 TO 1+32 (APPROX.))
SCALE: N.T.S.

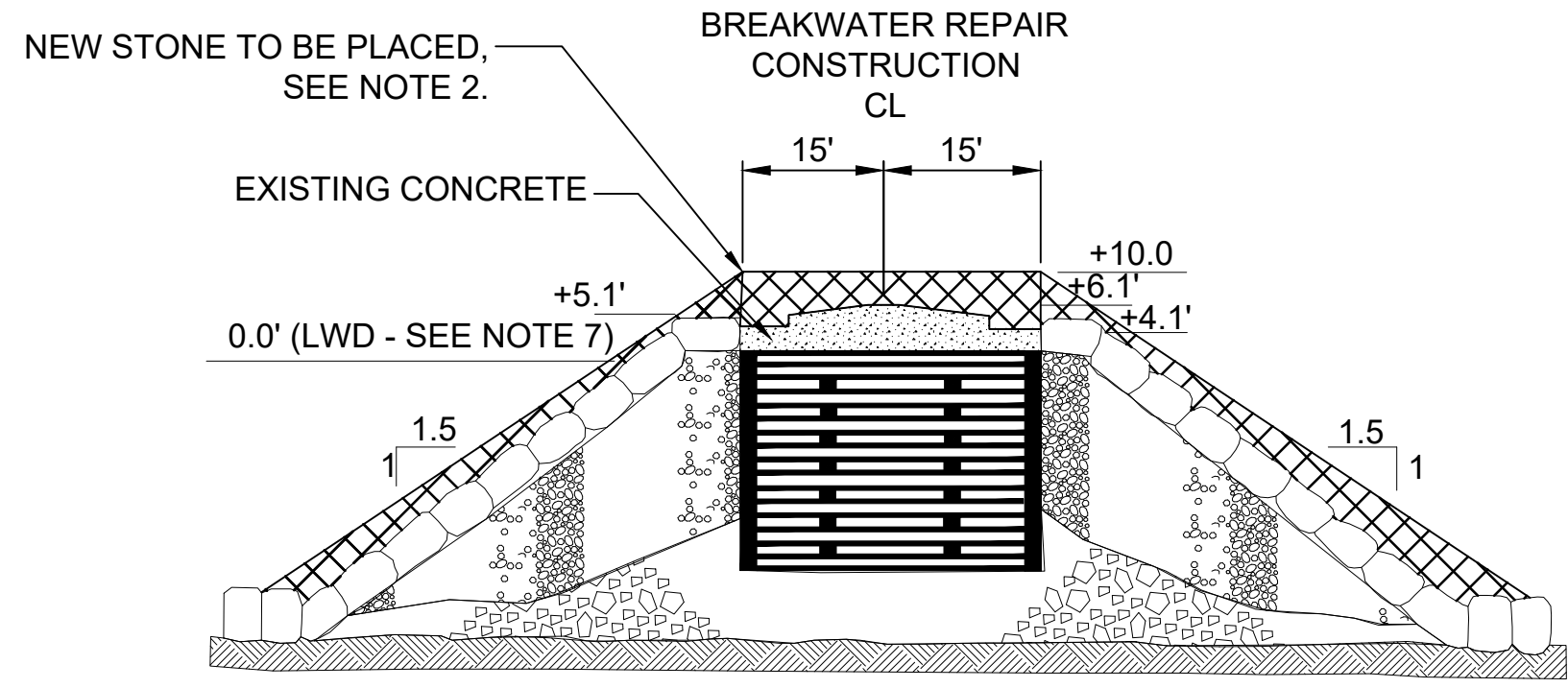

G9 REPAIRED DETACHED BREAKWATER REACH A (APPLIES STA. 1+32 TO 2+20 (APPROX.))
SCALE: N.T.S.

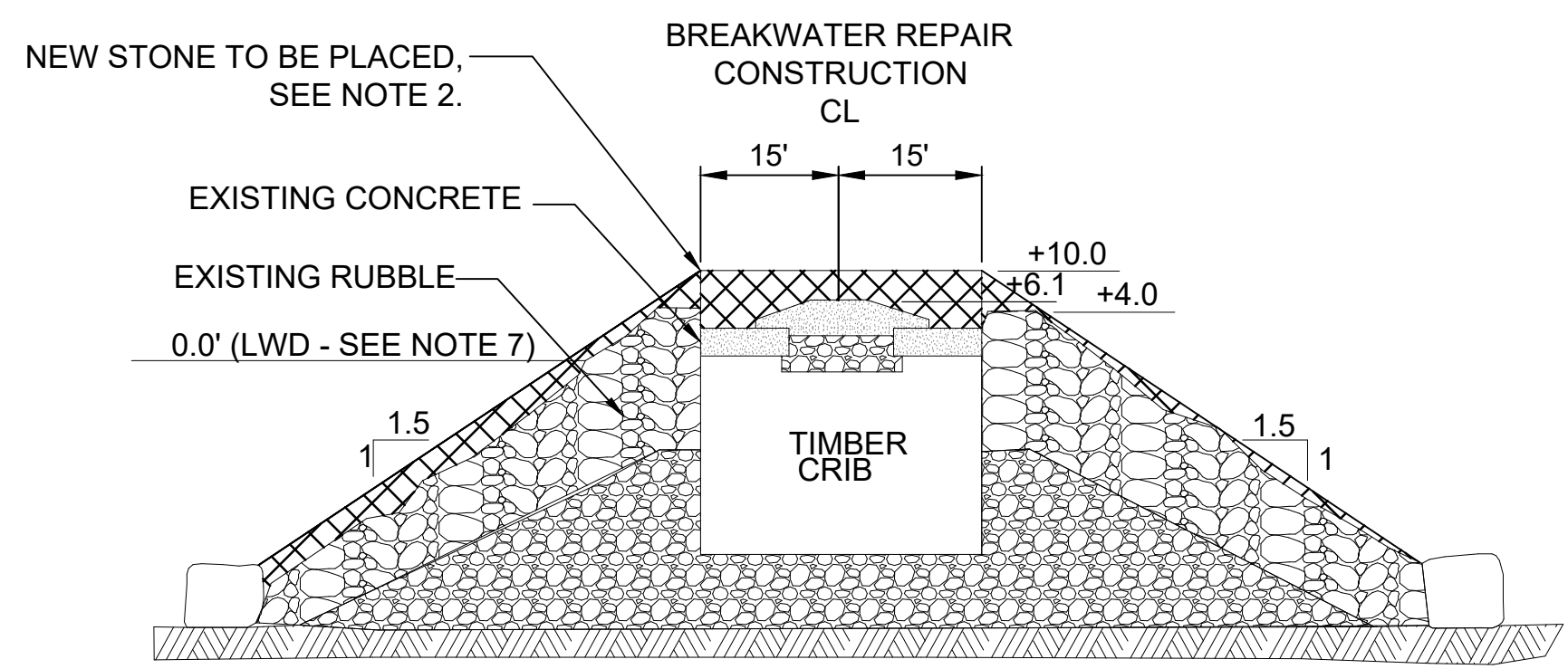

C9 REPAIRED DETACHED BREAKWATER REACH B (APPLIES STA. 2+20 TO 3+20 (APPROX.))
SCALE: N.T.S.

NOTES

1. FOR REPAIR SECTION L9, PLACE STONE ALONG THE EXISTING RUBBLEMOUND SLOPES TO FILL EXISTING GAPS AND TO MEET THE REPAIR SECTION GEOMETRY SHOWN.
2. FOR REPAIR SECTIONS C9 AND G9, PLACE STONE ALONG THE EXISTING RUBBLEMOUND SLOPES AND ON TOP OF THE CONCRETE CAP TO FILL EXISTING GAPS AND TO MEET THE REPAIR SECTION GEOMETRY SHOWN.
3. CONTRACTOR SHALL REMOVE OR REPOSITION EXISTING STONES TO ENSURE NEW STONE OVERLAY INTERLOCKS WELL WITH THE EXISTING STONE.
4. ALL DEBRIS IS TO BE REMOVED FROM BREAKWATER PRIOR TO PLACING NEW STONE.
5. ALL STONE PLACEMENT TO REMAIN WITHIN THE FOOTPRINT OF THE EXISTING ARMOR STONE EXTENTS.
6. SELECT STONES WITH ASPECT RATIOS FROM 2.5:1 TO 4:1 FOR PLACEMENT ALONG CREST TO ASSIST IN FITTING STONE WITHIN REQUIRED REPAIR SECTIONS. ALIGN STONES AT CREST WITH LONGEST AXIS PARALLEL TO THE AXIS OF THE STRUCTURE.
7. ELEVATIONS SHOWN THIS SHEET ARE REFERENCED TO LOW WATER DATUM (LWD). FOR REFERENCE, 0.0' (LWD) = 577.5' (IGLD85) = 578.03' (NAVD88).
8. SEE SHEET R-001 FOR ORIGINAL DESIGN SECTIONS.
9. SEE SHEET C-102 FOR REACH LOCATIONS AND STATIONING.



US Army Corps of Engineers®

MARK	DESCRIPTION	DATE

DESIGNED BY: S. CRETEN	ISSUE DATE: JULY 14, 2023
DRAWN BY: N. BORN	SOLICITATION NO. : W912P623-B-0007
CHECKED BY: S. CRETEN	CONTRACT NO. : W912P623-C-XXXX
SUBMITTED BY: P. HINCK	
ANSI D	SIZE

U.S. ARMY CORPS OF ENGINEERS
CHICAGO DISTRICT
231 S. LASALLE ST. SUITE 1500
CHICAGO, ILLINOIS 60604

MICHIGAN CITY
EAST PIER AND DETACHED BREAKWATER REPAIR - FY23
MICHIGAN CITY, INDIANA

BREAKWATER REPAIR SECTIONS

SHEET ID
C-501



07/14/2023

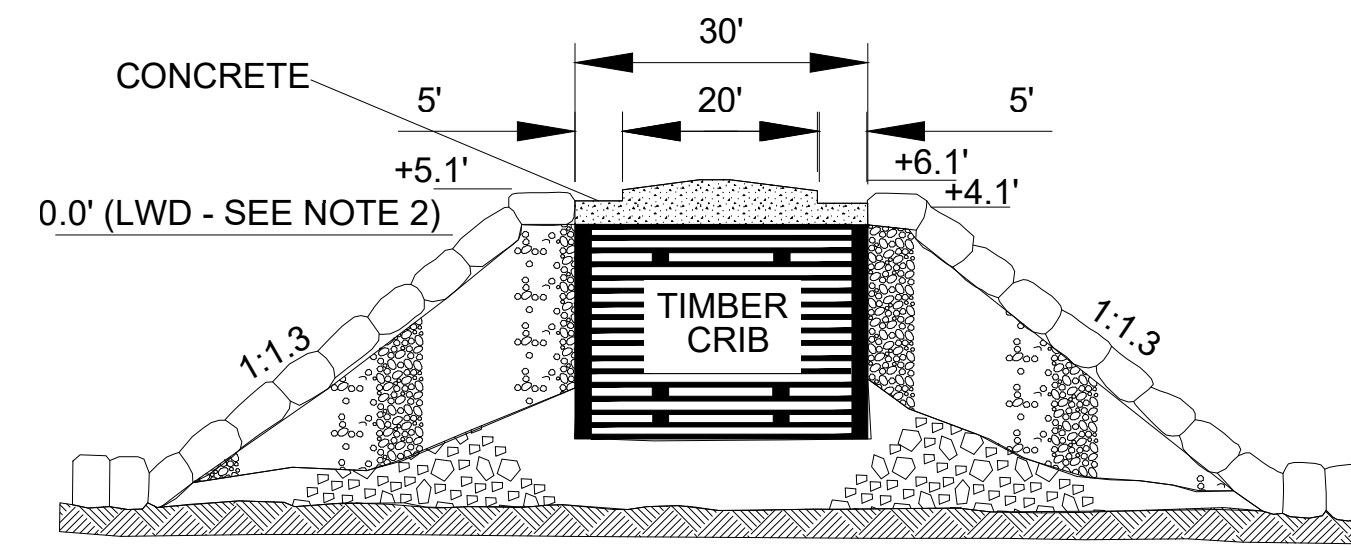

DETACHED BREAKWATER
SECTION AT REACH A
YEAR OF COMPLETION 1903
CONCRETE SUPR BUILT 1923
RIP RAP PLACED 1939-40
CONCRETE CAP REBUILT 1978

L10 DETACHED BREAKWATER REACH A
SCALE: NTS

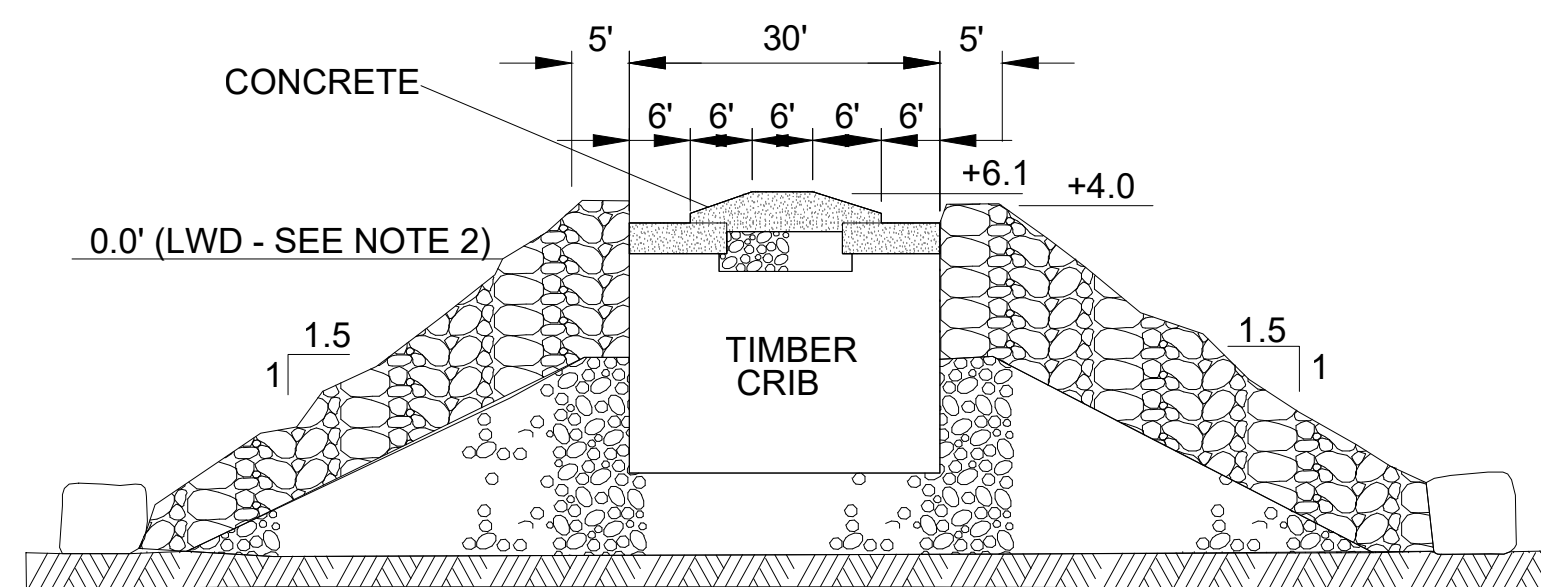

DETACHED BREAKWATER
SECTION AT REACH B
YEAR OF COMPLETION 1903
CONCRETE SUPR BUILT 1925
RIP RAP PLACED 1968-69

G10 DETACHED BREAKWATER REACH B
SCALE: NTS

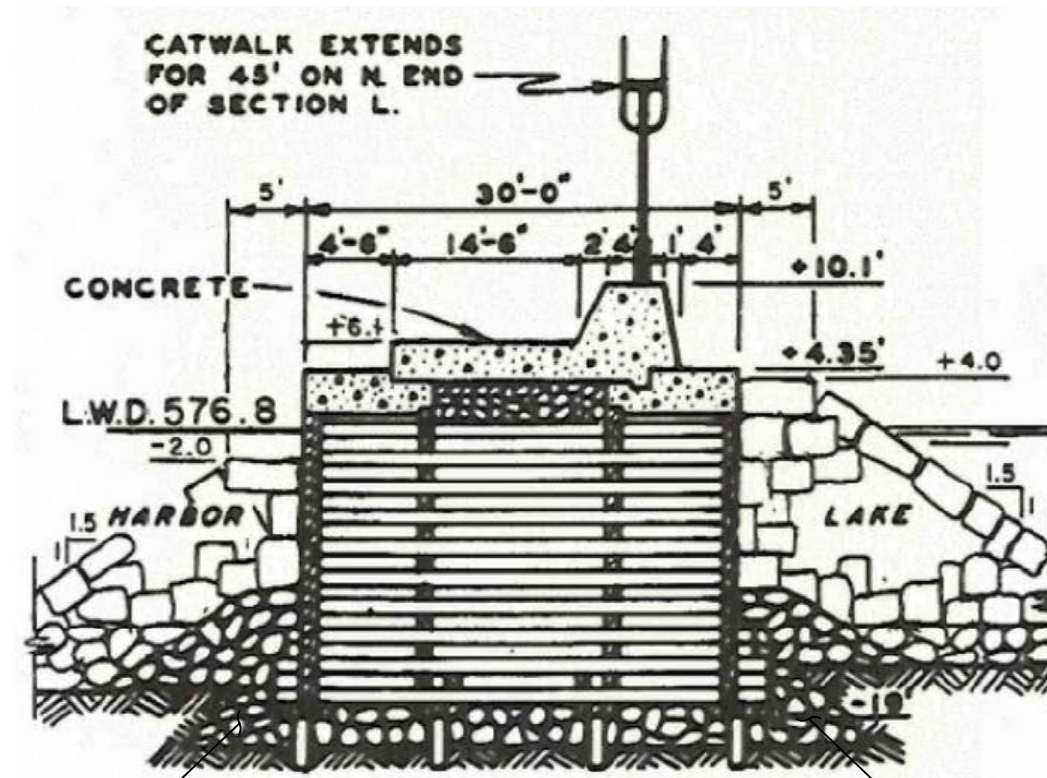

EAST PIER
SECTION AT M, M-1
YEAR OF COMPLETION 1902
CONCRETE SUPR BUILT 1931
SECTION M AS SHOWN
SECTION M-1 RIPRAP LAKESIDE ONLY.

POSSIBLE ROCK SUBSURFACE OF LAKE BED

B3 EAST PIER - SOUTHEAST OF LIGHTHOUSE
SCALE: NTS

- SECTION NOTES:
- SECTION APPLIES TO THE SOUTHEAST OF THE LIGHTHOUSE. THERE IS NO AVAILABLE INFORMATION UNDER OR NORTHWEST OF LIGHTHOUSE, BUT CONTRACTOR SHALL ASSUME ROCK MAY BE PRESENT SUBSURFACE OF THE LAKE BED ALONG THE ENTIRE PERIMETER OF THE EAST PIER.
 - L.W.D. REFERENCED IN THIS SECTION IS BELIEVED TO BE IGLD55 (FIELD VERIFY)

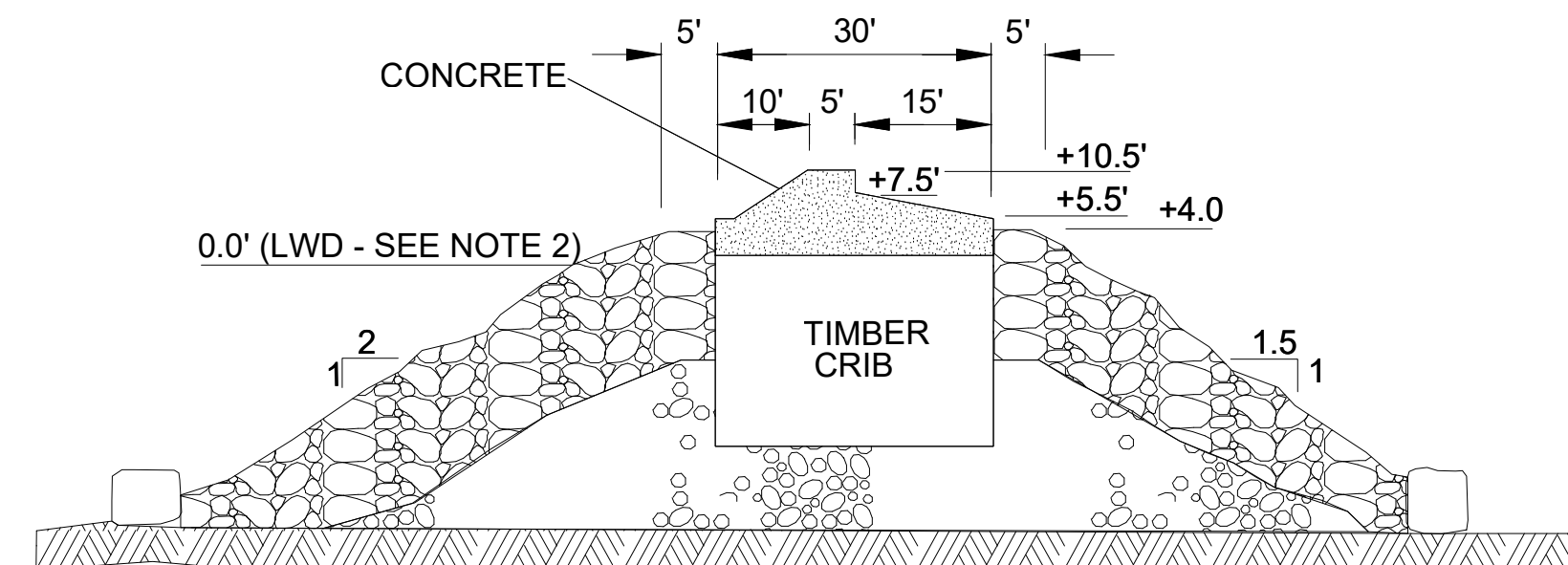

DETACHED BREAKWATER
SECTION AT REACH C
YEAR OF COMPLETION 1903
CONCRETE SUPR BUILT 1911
RIP RAP PLACED 1968-69

B10 DETACHED BREAKWATER REACH C
SCALE: NTS

NOTES

- ORIGINAL DESIGN BREAKWATER SECTIONS PROVIDED FOR CONTRACTOR REFERENCE. REFER TO C-102 FOR REACH LOCATIONS.
- ELEVATIONS SHOWN THIS SHEET ARE REFERENCED TO LOW WATER DATUM (LWD). FOR REFERENCE, 0.0' (LWD) = 577.5' (IGLD85) = 578.03' (NAVD88).



US Army Corps of Engineers®

DATE	DESCRIPTION

ISSUE DATE: JULY 14, 2023	SOLICITATION NO.: W912P623-B-0007	CONTRACT NO.: W912P623-C-XXXX
DESIGNED BY: S. CRETEN	DRAWN BY: N. BORN	CHECKED BY: S. CRETEN
SUBMITTED BY: P. HINCK		
ANSI D	SIZE:	

U.S. ARMY CORPS OF ENGINEERS
CHICAGO DISTRICT
231 S. LA SALLE ST. SUITE 1500
CHICAGO, ILLINOIS 60604

BARR
PRAIRIE-HANSON
304 E 101st Street, Suite 400
Chicago, IL 60642

MICHIGAN CITY
EAST PIER AND DETACHED BREAKWATER REPAIR - FY23
MICHIGAN CITY, INDIANA

ORIGINAL DESIGN BREAKWATER AND
EAST PIER SECTIONS

SHEET ID
R-001



07/14/2023

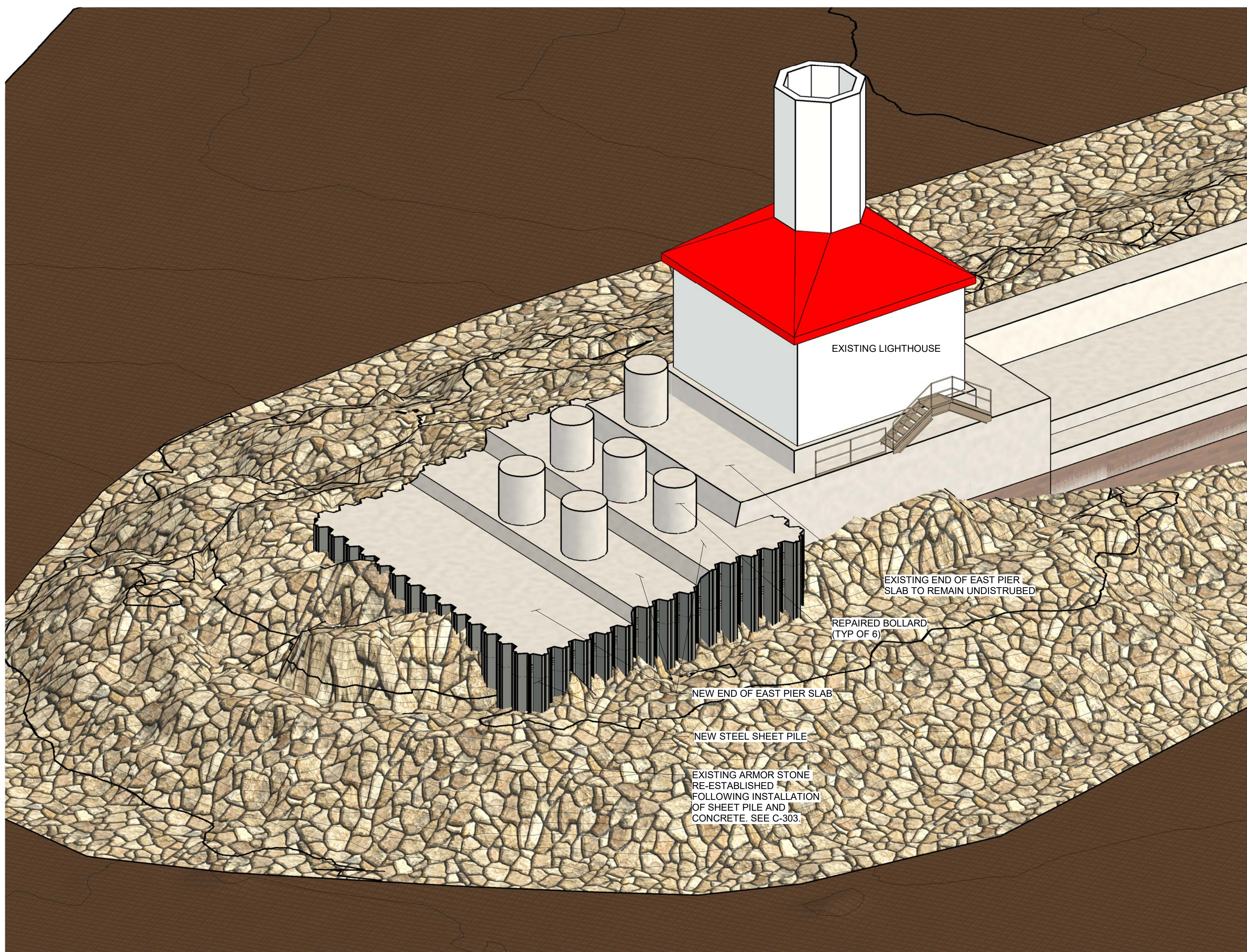

ORTHOGRAPHIC NOTES:
 1. ORTHOGRAPHIC VIEWS ARE NOT TO SCALE. THEY ARE FOR ILLUSTRATIVE PURPOSES ONLY AND SHOULD NOT BE USED FOR CONSTRUCTION OR ESTIMATING PURPOSES.
 2. FINAL CONDITION SHOWN.

D6 ORTHOGRAPHIC: PIER
 NTS

GENERAL NOTES:
 1. THESE NOTES ARE COMPLEMENTARY TO THE SPECIFICATIONS AND DRAWINGS AND REPRESENT MINIMUM REQUIREMENTS. REFER TO SPECIFICATIONS FOR ADDITIONAL REQUIREMENTS.
 2. ALL WORK SHALL BE PERFORMED IN ACCORDANCE WITH THE 2012 INTERNATIONAL BUILDING CODE W/ 2012 INDIANA BUILDING CODE AMENDMENTS.
 3. ALL WORK SHALL BE PERFORMED IN STRICT COMPLIANCE WITH APPLICABLE FEDERAL, STATE AND LOCAL CODES AND REGULATIONS. THE WORK SHALL COMPLY WITH ALL APPLICABLE REGULATIONS OF OSHA (OCCUPATIONAL SAFETY AND HEALTH ADMINISTRATION).
 4. ALL EXISTING INFORMATION NOT VISIBLE IS PRESENTED ON THE BASIS OF LIMITED HISTORICAL RECORD DRAWINGS AND MAY NOT BE ACCURATE.
 5. ASIDE FROM DEMOLITION REQUIRED IN THESE DRAWINGS, CONTRACTOR SHALL PROTECT AND PREVENT DISTURBANCE TO THE EXISTING STRUCTURE.
 6. THE STRUCTURE IS DESIGNED TO FUNCTION AS A UNIT UPON COMPLETION. THE CONTRACTOR IS RESPONSIBLE FOR FURNISHING ALL TEMPORARY BRACING AND/OR SUPPORT THAT MAY BE REQUIRED AS THE RESULT OF THE CONTRACTOR'S CONSTRUCTION METHODS AND/OR SEQUENCES, REFER TO THE CONTRACT SPECIFICATIONS.
 7. DO NOT SCALE THESE DRAWING. USE DIMENSIONS.
 8. ELEVATIONS ARE REFERENCED TO NAVD88, US FEET.

DESIGN CRITERIA:
 1. DESIGN CODES:
 A. AMERICAN SOCIETY OF CIVIL ENGINEERS, ASCE 7-10.
 B. AISC 360-10, STEEL SPECIFICATION FOR STRUCTURAL STEEL BUILDINGS.
 C. ACI 318-14, BUILDING CODE REQUIREMENTS FOR STRUCTURAL CONCRETE AND COMMENTARY.
 2. DESIGN GUIDANCE:
 A. USACE EM 1110-2-2104 CONCRETE HYDRAULIC STRUCTURES (2016)
 B. USACE EM 1110-2-2107 DESIGN OF HYDRAULIC STEEL STRUCTURES (2022)
 C. USACE EM 1110-2-2503 DESIGN OF SHEET PILE CELLULAR COFFERDAM AND RETAINING STRUCTURES (1989)
 D. USACE EM 1110-2-2504 DESIGN OF SHEET PILE WALLS (1994)
 3. LIVE LOADS:
 A. PEDESTRIAN LIVE LOAD: 60PSF (USUAL)
 B. CONSTRUCTION LIVE LOAD: 100 PSF (UNUSUAL)
 4. WAVE LOAD (UNUSUAL):
 A. CASE 1: 20- YEAR WATER LEVEL COMBINED WITH 10- YEAR WAVE
 B. CASE 2: 10- YEAR WATER LEVEL COMBINED WITH 20- YEAR WAVE
 5. ICE LOAD (UNUSUAL):
 A. ICE THERMAL AND IMPACT:
 a. 10,000LBS/FT
 B. ICE BUILDUP ON STRUCTURE:
 a. UNIT WEIGHT OF ICE: 60PCF
 b. THICKNESS OF ICE: 2 FT
 6. SEISMIC LOADS:
 A. RISK CATEGORY: I
 B. IMPORTANCE FACTOR: 1.00
 C. SITE CLASSIFICATION: D
 D. SDS: 0.169g
 E. SD1: 0.174g
 F. SMS: 0.253g
 G. SMI: 0.280g
 H. SEISMIC DESIGN CATEGORY:
 7. GEOTECHNICAL LOADS:
 A. FILL STONE: $\gamma_{SAT} = 130$ PCF, $\phi = 32^\circ$
 B. NATIVE UPPER GRANULAR SOIL: $\gamma_{SAT} = 120$ PCF, $\phi = 31^\circ$
 C. NATIVE LOWER GRANULAR SOIL: $\gamma_{SAT} = 125$ PCF, $\phi = 36^\circ$
 D. NATIVE CLAY: $\gamma = 130$ PCF, $\phi = 29^\circ$
 8. SHEET PILING SHALL BE PROTECTED WITH ROCK SHOES AND DRIVEN TO REFUSAL. REFER TO CONTRACT SPECIFICATIONS FOR PILE DRIVING REFUSAL CRITERIA.

CONCRETE:
 1. CONCRETE IN ACCORDANCE WITH THE FOLLOWING. SEE SPECIFICATION SECTION 03 30 00 FOR ADDITIONAL REQUIREMENTS.
 A. ALL CONCRETE UNO:
 a. MIN STRENGTH: 4500 PSI
 B. GROUT:
 a. MIN STRENGTH: 2000 PSI
 b. SLUMP (ASTM C143): $9" \pm 1.5"$
 c. SUBMIT ANTIWASHOUT AGENT FOR REVIEW AND APPROVAL.
 2. CONCRETE REINFORCEMENT F = 60 KSI (ASTM A615, GR. 60)

STEEL SHEET PILE:
 1. SHEET PILE SIZE: NZ-26, OR APPROVED EQUIVALENT

STRUCTURAL STEEL:
 1. ALL STEEL CHANNELS, ANGLES, AND PLATES (UNO): ASTM A36
 2. ROLLED SHAPES: ASTM A572 GR 50
 3. BOLTS: ASTM A325
 4. ANCHOR BOLTS: ASTM F1554 GR 55
 5. HEADED STUDS: ASTM A108
 6. WELDING ELECTRODES: E70XX
 7. ALL STRUCTURAL STEEL: HOT-DIPPED GALVANIZED (EXCEPT SHEET PILE)

STEEL TIE-ROD
 1. MATERIAL PROPERTIES (UNO):
 A. TIE-RODS (FULLY THREADED): ASTM A615, GR 100

FILL STONE
 1. MATERIAL PROPERTIES: INDIANA DOT COARSE AGGREGATE #2

ABBREVIATIONS

DIA OR Ø...	DIAMETER
EL...	ELEVATION
EW...	EACH WAY
EXIST...	EXISTING
GALV...	GALVANIZED
NTS...	NOT TO SCALE
OC...	ON CENTER
REINF...	REINFORCED
T&B...	TOP AND BOTTOM
TYP...	TYPICAL
UNO...	UNLESS NOTED OTHERWISE

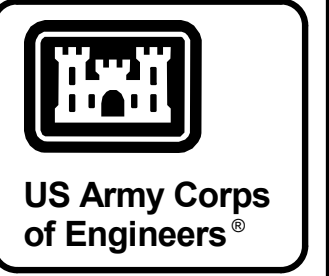

MARK	DESCRIPTION	DATE

ISSUE DATE: JULY 14, 2023
 SOLICITATION NO.: W912P253-B-0007
 CONTRACT NO.: W912P253-C-XXXX

DESIGNED BY: K. SEIDLER
 DRAWN BY: B. HOROB
 CHECKED BY: B. SILJENBERG
 SUBMITTED BY: P. HINCK

U.S. ARMY CORPS OF ENGINEERS
 CHICAGO DISTRICT
 231 S. ASHLEIGH ST., SUITE 1600
 CHICAGO, ILLINOIS 60604

BARR
 Prairie-Hanson
 P.E. 101
 Member-Professional Engineer

MICHIGAN CITY
 EAST PIER AND DETACHED BREAKWATER REPAIR - FY23
 MICHIGAN CITY, INDIANA

STRUCTURAL
 NOTES AND ORTHOGRAPHIC

SHEET ID
S-001



- SHEET NOTES:
- ORTHOGRAHIC VIEWS SHOW GENERAL RECOMENDED SEQUENCING. OPTIONAL CONSTRUCTION SEQUENCING:
 - PERFORM PREEXISTING CONDITION SURVEYS
 - CLEAR PILE DRIVE LINES OF NO MORE THAN A 30 LINEAR FEET SEGMENT AT A TIME
 - INSTALL SHEET PILING ALONG STARTING AT ONE END
 - PLACE FILL STONE FOR SEGMENT JUST COMPLETED, BUT NO MORE THAN 13' ABOVE ARMOR STONE OR LAKE BOTTOM ON LAKE SIDE
 - PLACE ARMOR STONE FOR SEGMENT JUST COMPLETED, NO HIGHER THAN FILL STONE
 - PERFORM PARTIAL REMOVAL OF EXISTING EAST PIER CAP
 - INSTALL WALES AND TIE RODS
 - PLACE REMAINING FILL STONE
 - CORE EXISTING SLAB AND FILL WITH GROUT
 - INSTALL SLAB AND BOLLARD CASINGS
 - FINAL SEQUENCING IS THE RESPONSIBILITY OF THE CONTRACTOR AND IS TO BE SUBMITTED FOR REVIEW ACCORDING TO THE SPECIFICATIONS. NO MORE THAN 30'-0" OF ARMOR STONE ALONG THE DRIVE LINE MAY BE REMOVED AT A TIME.
 - ORTHOGRAHIC VIEWS ARE NOT TO SCALE. THEY ARE FOR ILLUSTRATIVE PURPOSES ONLY AND SHOULD NOT BE USED FOR CONSTRUCTION OR ESTIMATING PURPOSES. NOT ALL FEATURES MAY SHOW.

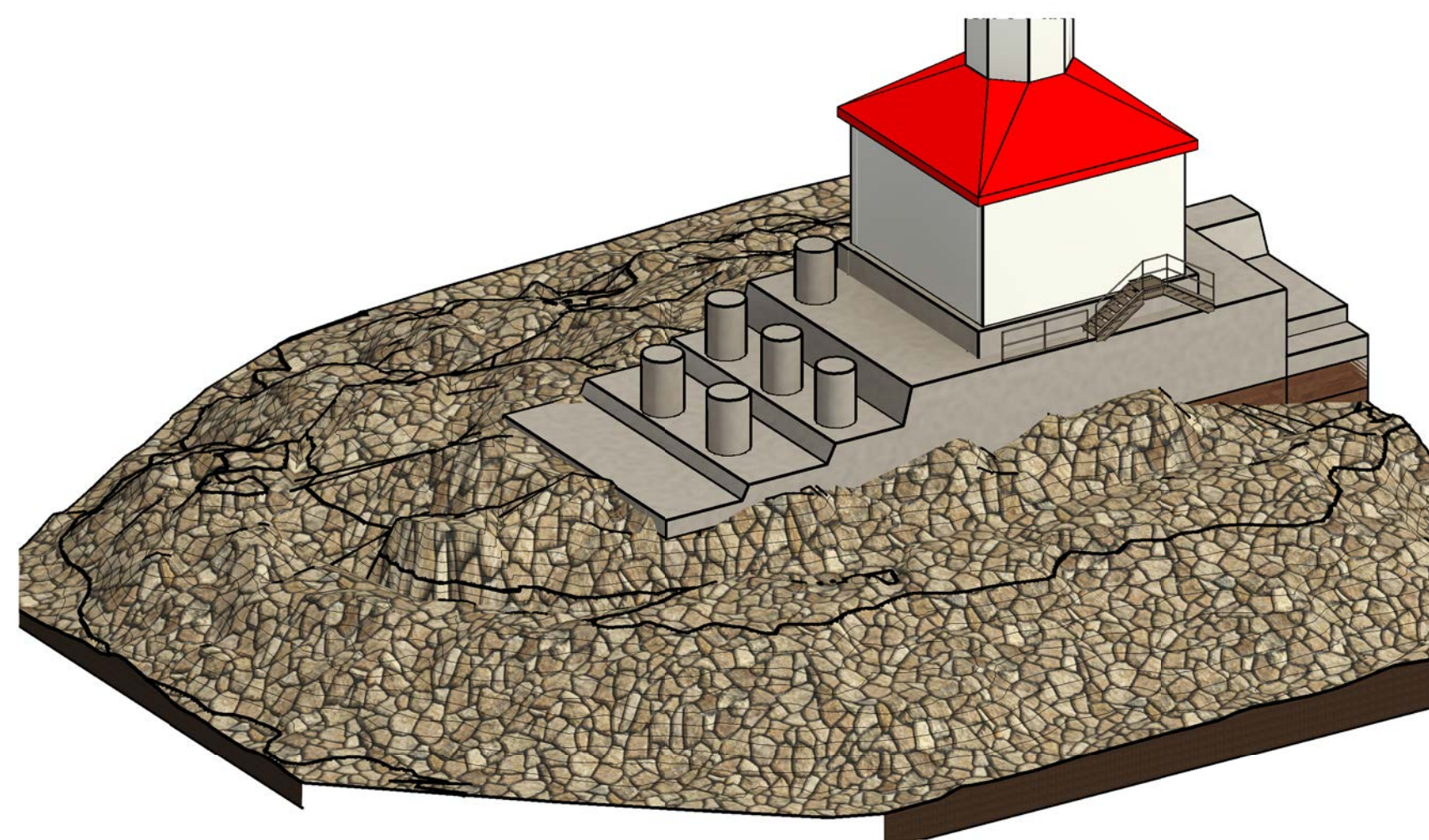

H3 ORTHOGRAHIC: EXISTING
NTS

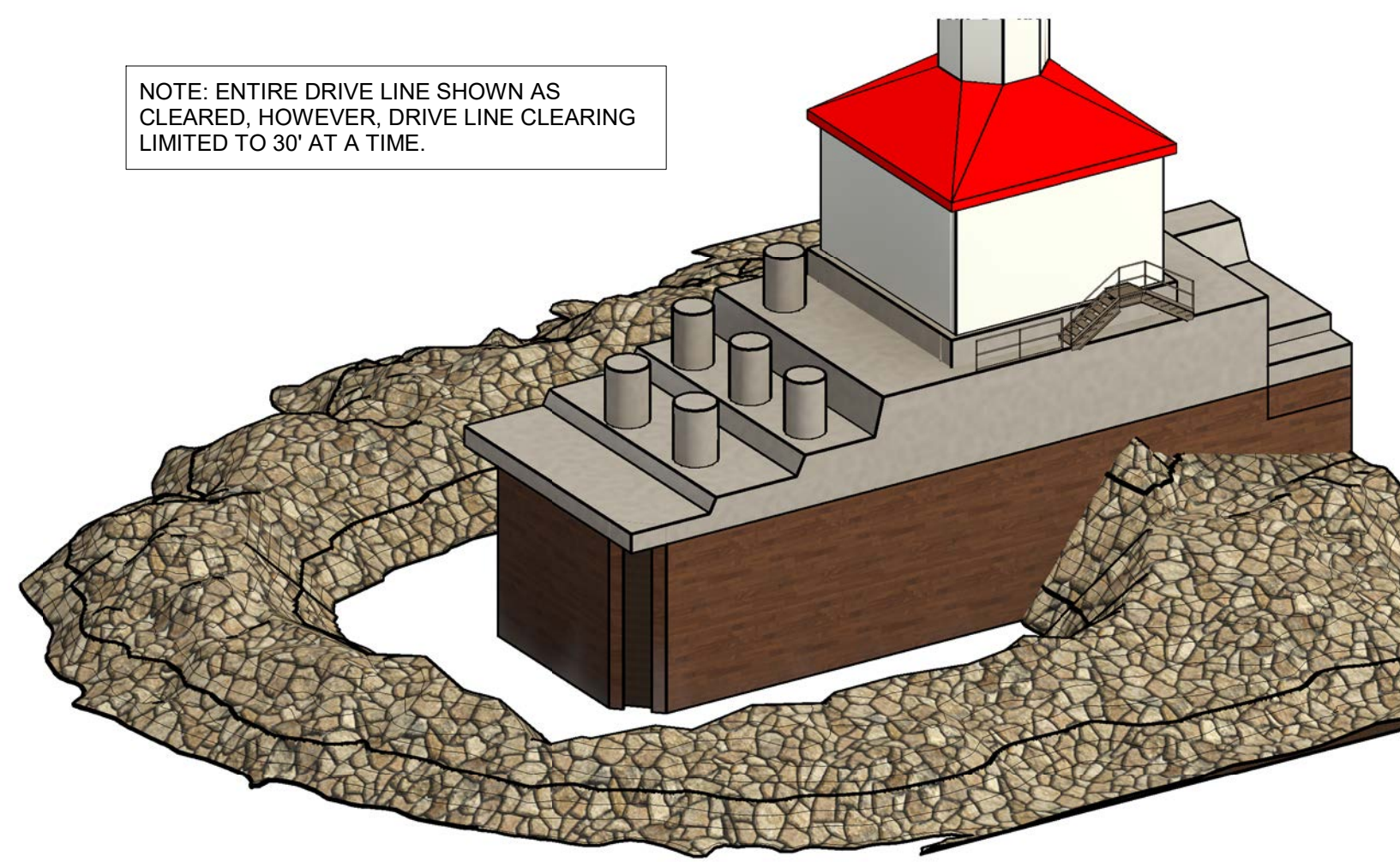

H9 ORTHOGRAHIC: ARMOR STONE REMOVAL
NTS

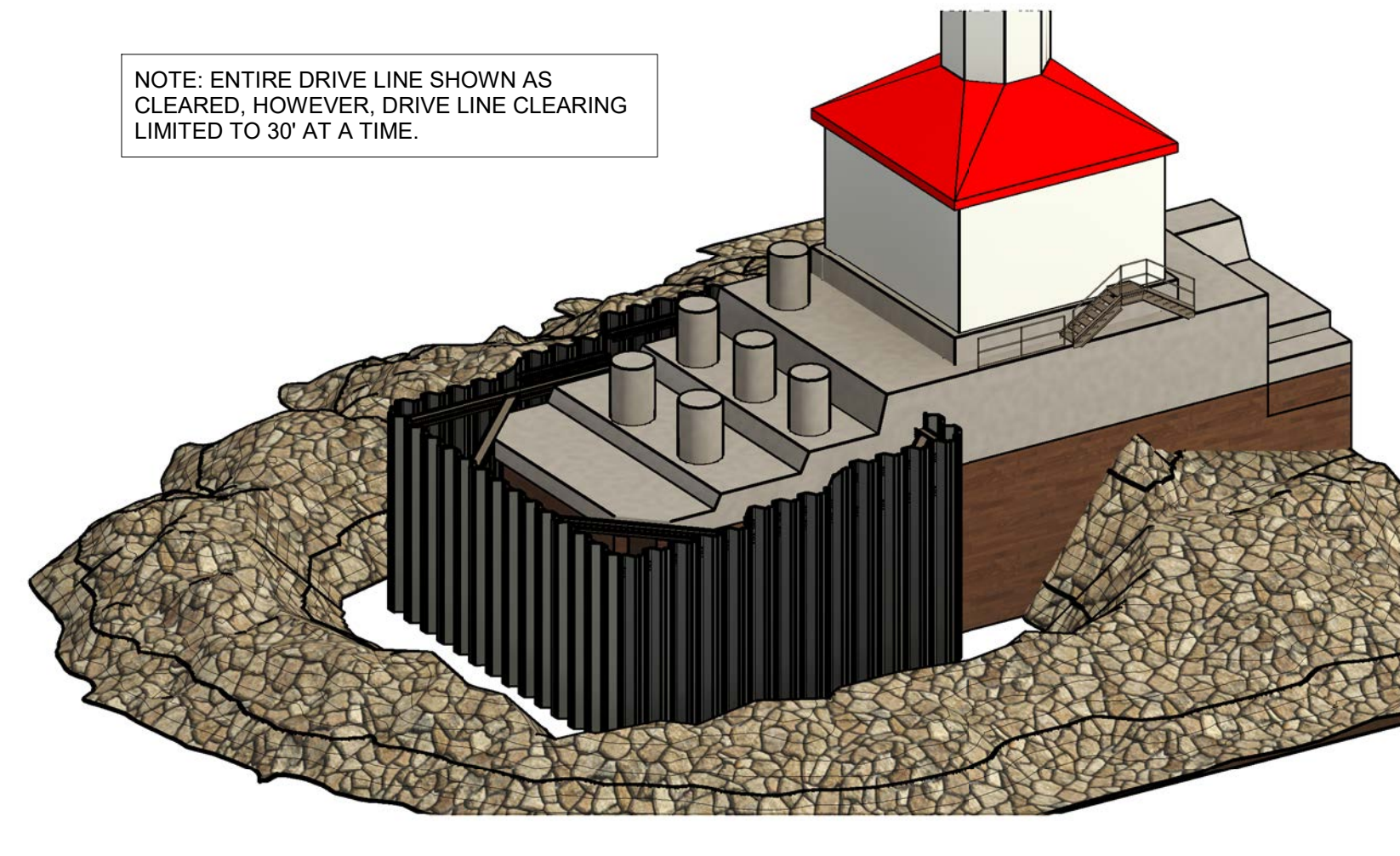

H16 ORTHOGRAHIC: NEW SHEET INSTALLATION
NTS

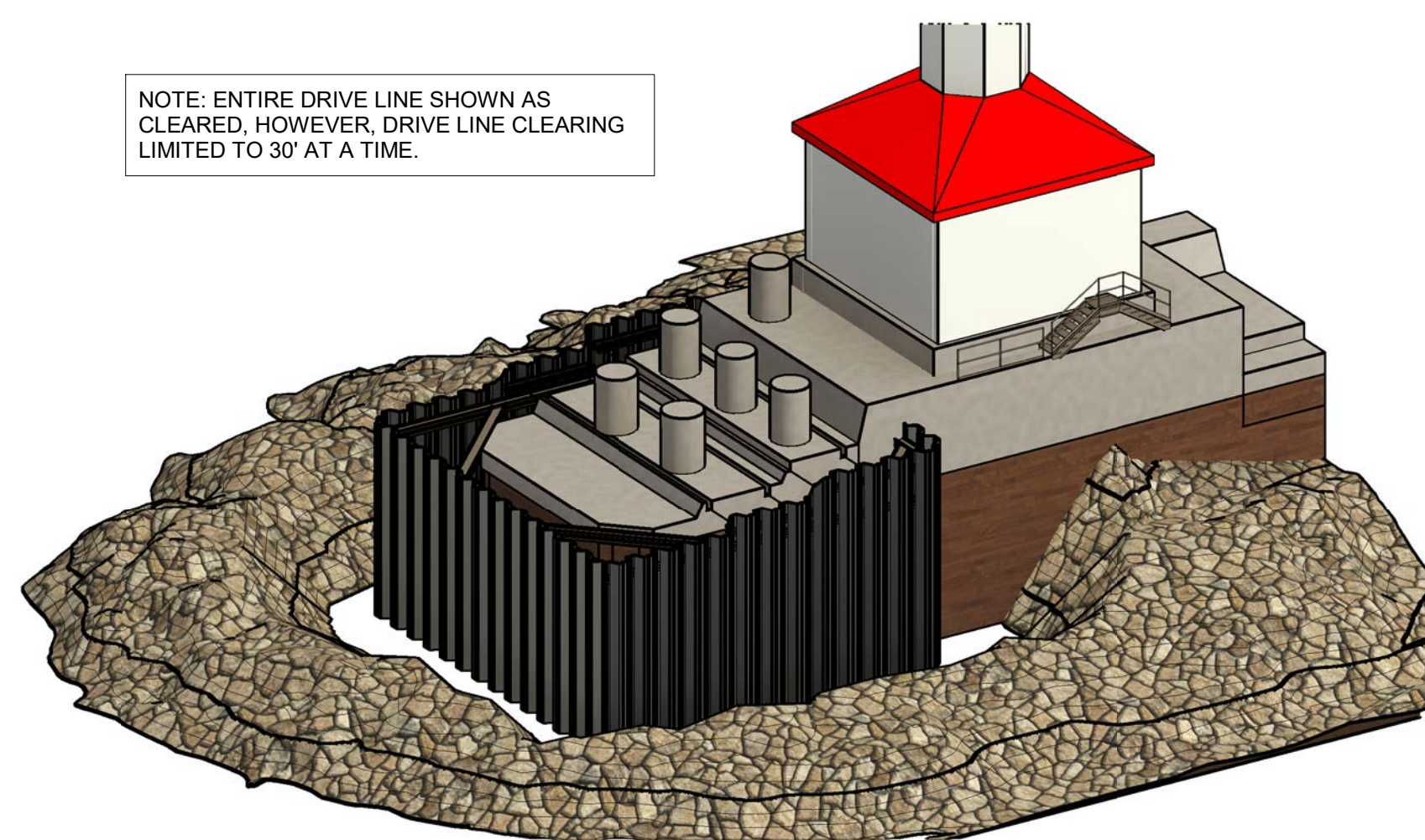

- DEMOLISH EXISTING CONCRETE AS NECESSARY TO ACCOMODATE REQUIRED WORK AS SPECIFIED ON S-101
- INSTALL WALES AND TIE RODS AS SPECIFIED ON S-102.
- BACKFILL WITH FILL STONE BETWEEN SHEETS AND EXISTING TIMBER CRIBBING AS SPECIFIED ON S-105.
- COREHOLE EXISTING SLAB AND FILL VOID WITH GROUT AS SPECIFIED ON S-101

B3 ORTHOGRAHIC: WALE INSTALLATION
NTS

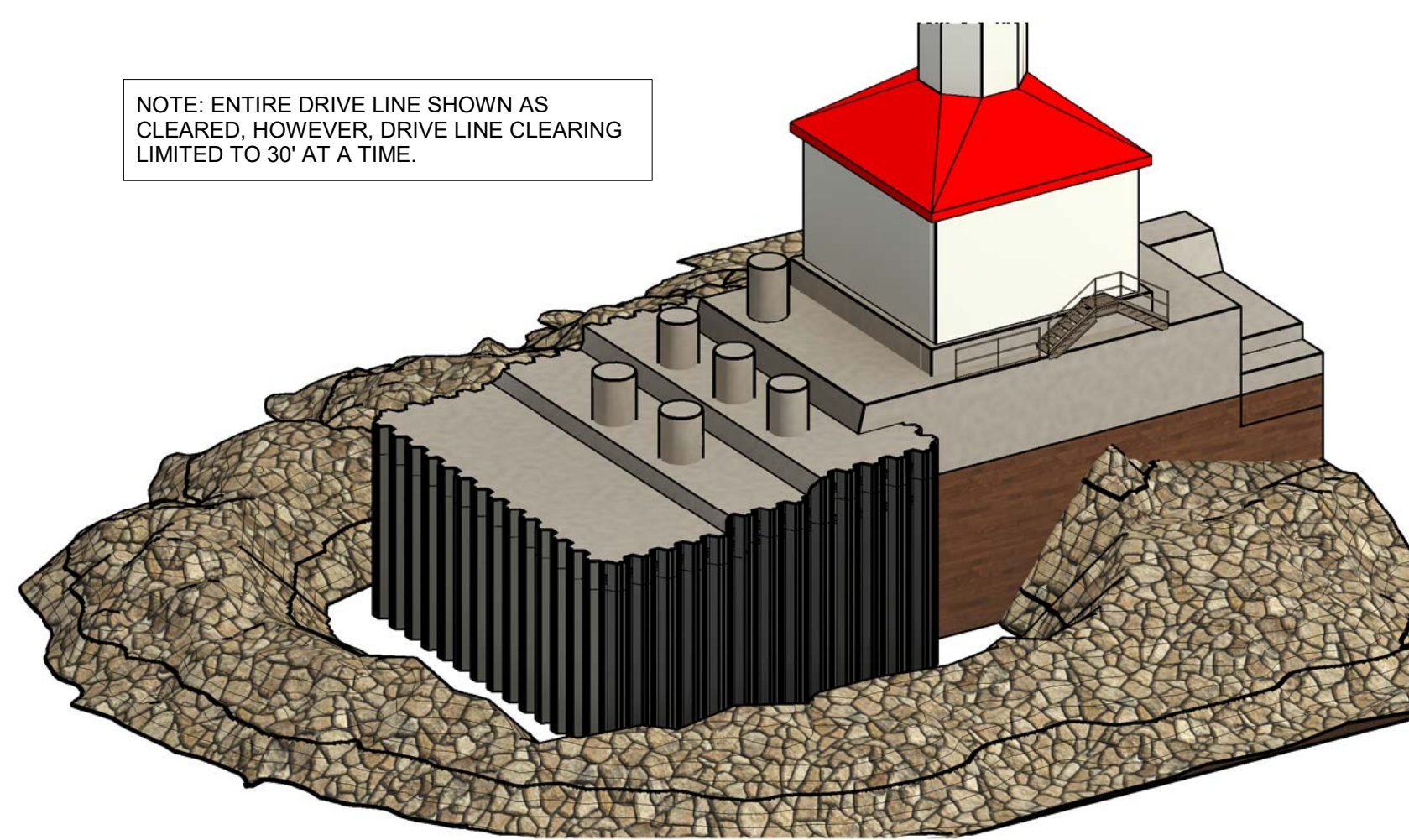

- INSTALL NEW CONCRETE SLAB AS SPECIFIED ON S-104.
- INSTALL NEW BOLLARD STEEL SLEEVES AND CONCRETE AS SPECIFIED ON S-105.

B8 ORTHOGRAHIC: CONCRETE SLAB & BOLLARD INSTALLATION
NTS

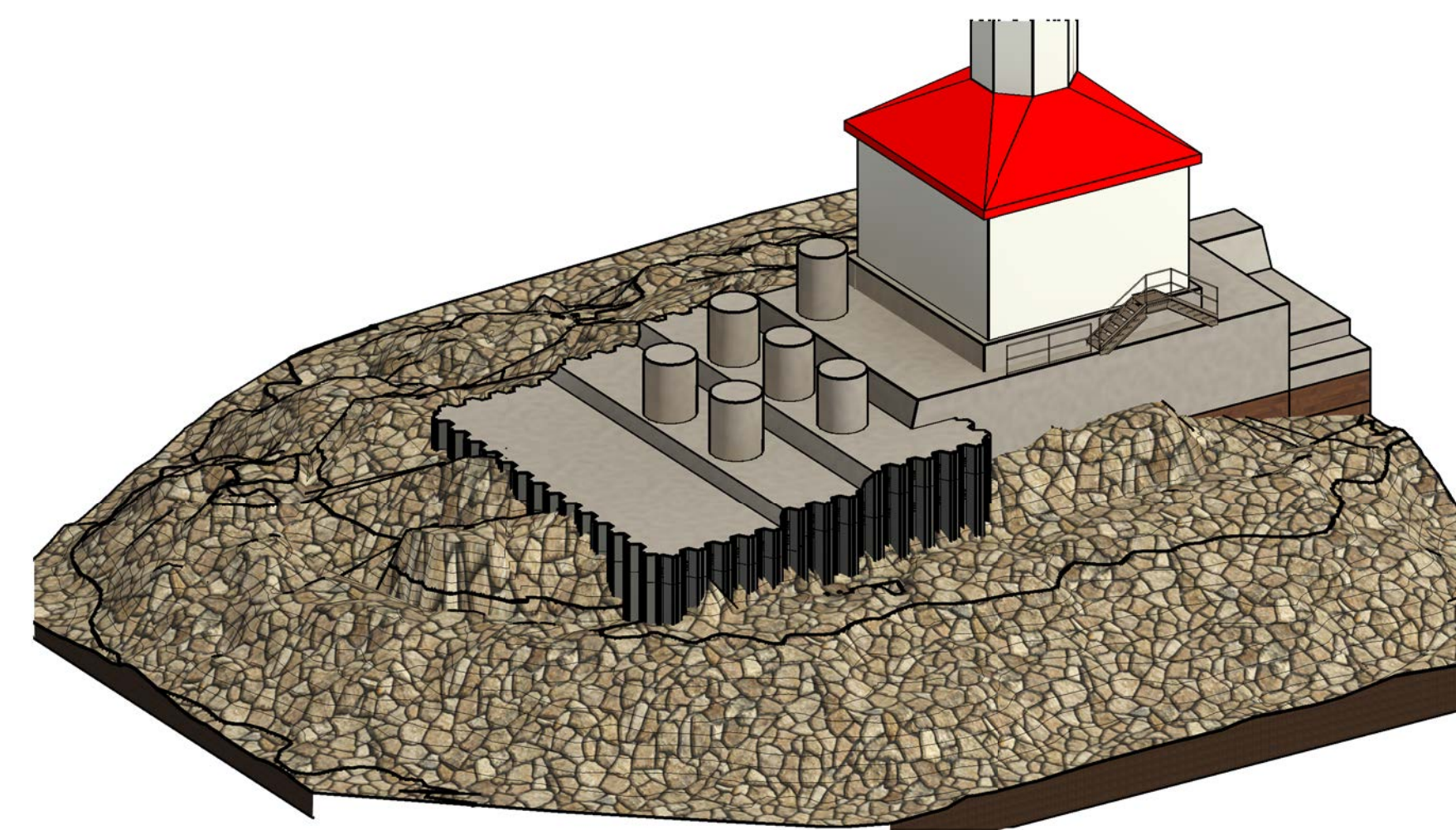

- REPLACE ARMOR STONE, C-303.

B15 ORTHOGRAHIC: ARMOR STONE INSTALLATION
NTS



MARK	DESCRIPTION	DATE

ISSUE DATE: JULY 14, 2023	SOLICITATION NO.: W912P623-B-007	CONTRACT NO.: W912P623-C-XXXX
DESIGNED BY: K. SEIDLER	DRAWN BY: B. HOROB	CHECKED BY: B. SILJENBERG
SUBMITTED BY: P. HINCK		SCALE: AS SHD
U.S. ARMY CORPS OF ENGINEERS CHICAGO DISTRICT 231 S. LA SALLE ST., SUITE 1600 CHICAGO, ILLINOIS 60604 		

MICHIGAN CITY
EAST PIER AND DETACHED BREAKWATER REPAIR - FY23
MICHIGAN CITY, INDIANA

STRUCTURAL - PHASING PLAN
ORTHOGRAHICS

SHEET ID
S-002



CERTIFIED FINAL - READY TO ADVERTISE

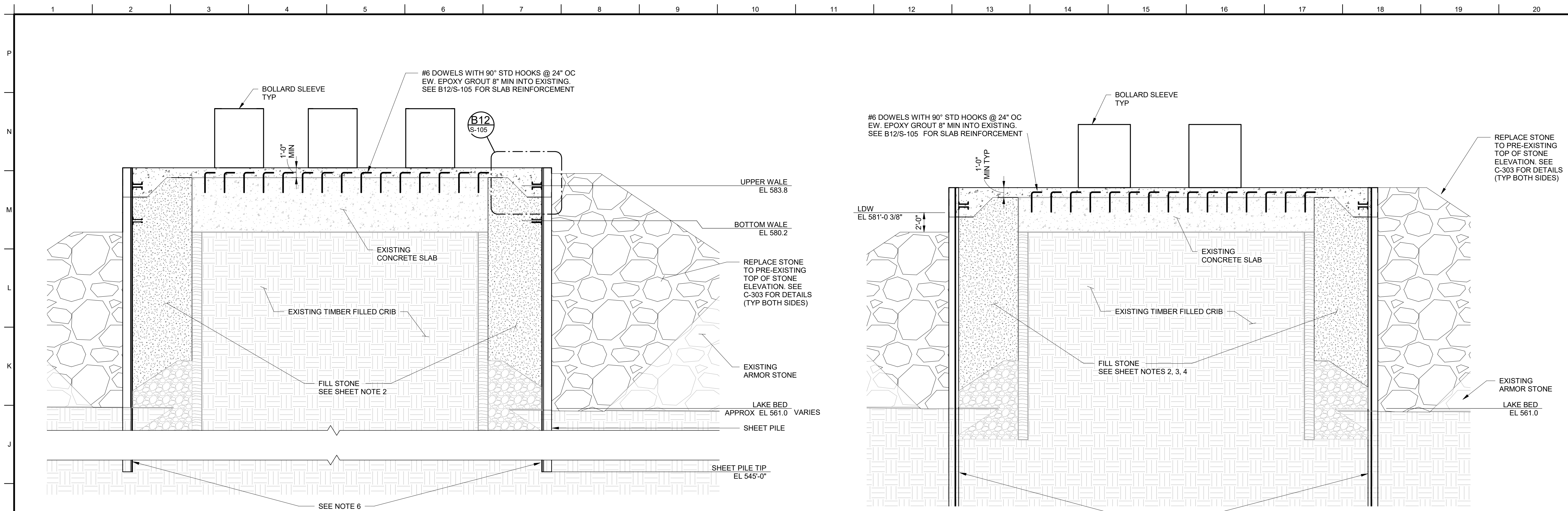

H4 SECTION: HIGH STEP
S-104 3/16" = 1'-0"

H14 SECTION: LOW STEP
S-104 3/16" = 1'-0"

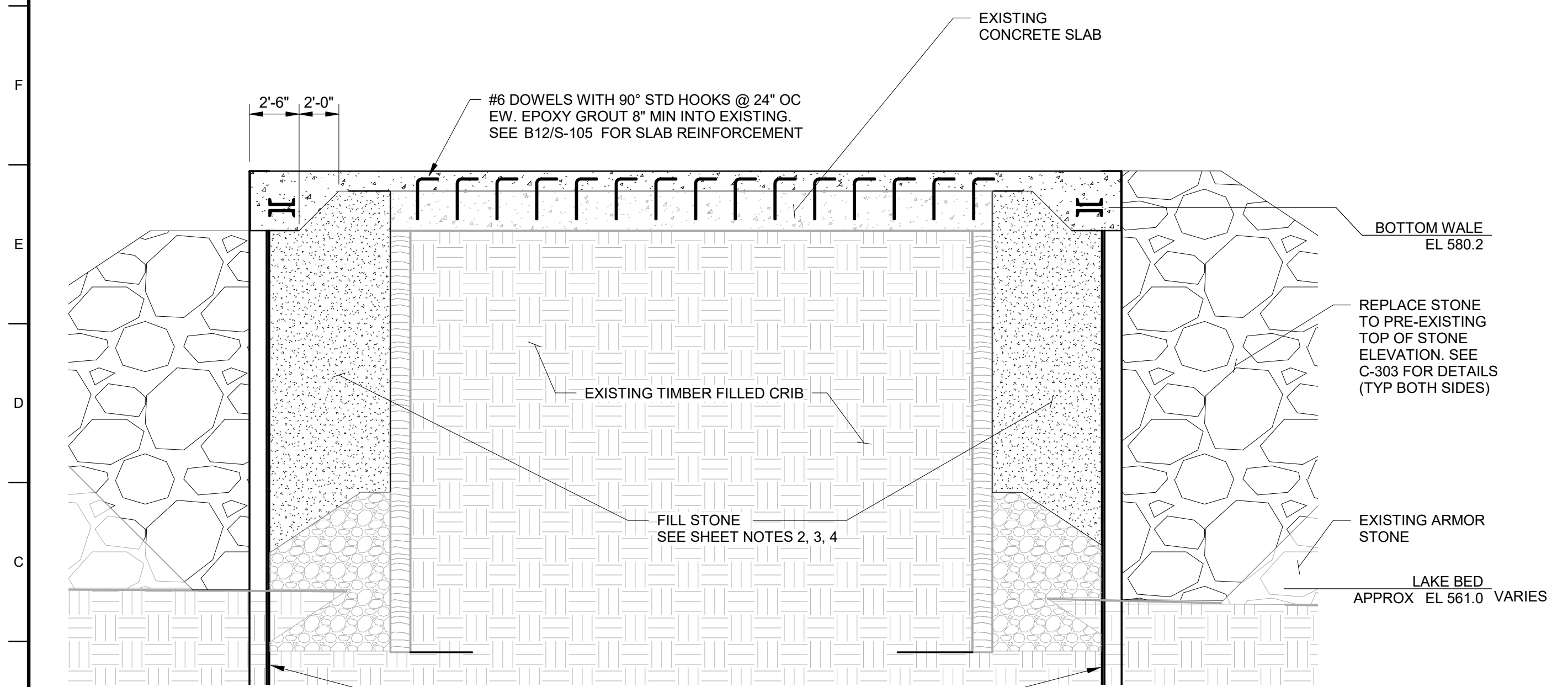

A3 SECTION: LOOKING NORTHWEST
S-104 3/16" = 1'-0"

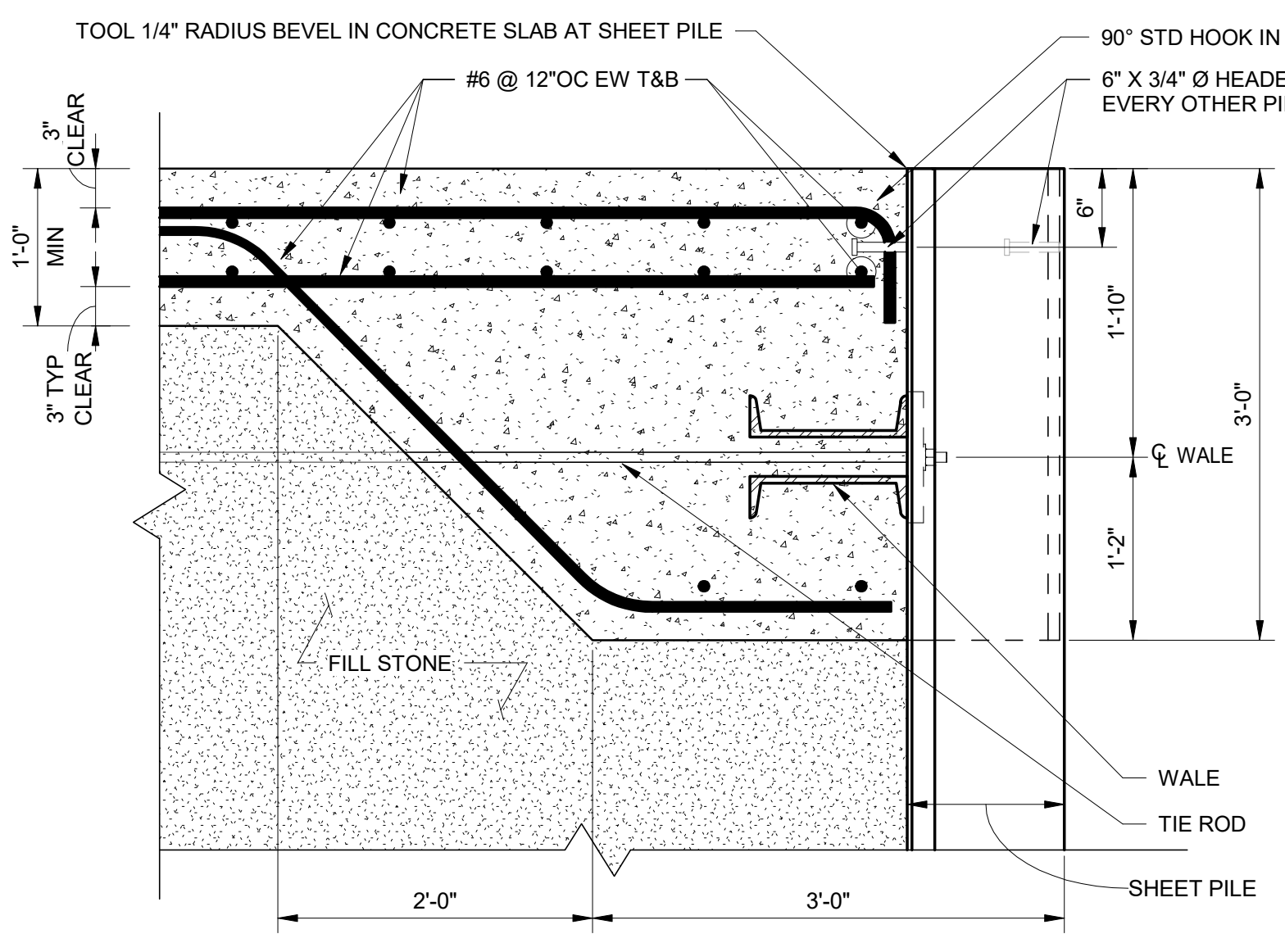

B12 SECTION: PEIR EDGE
S-105 1" = 1'-0"

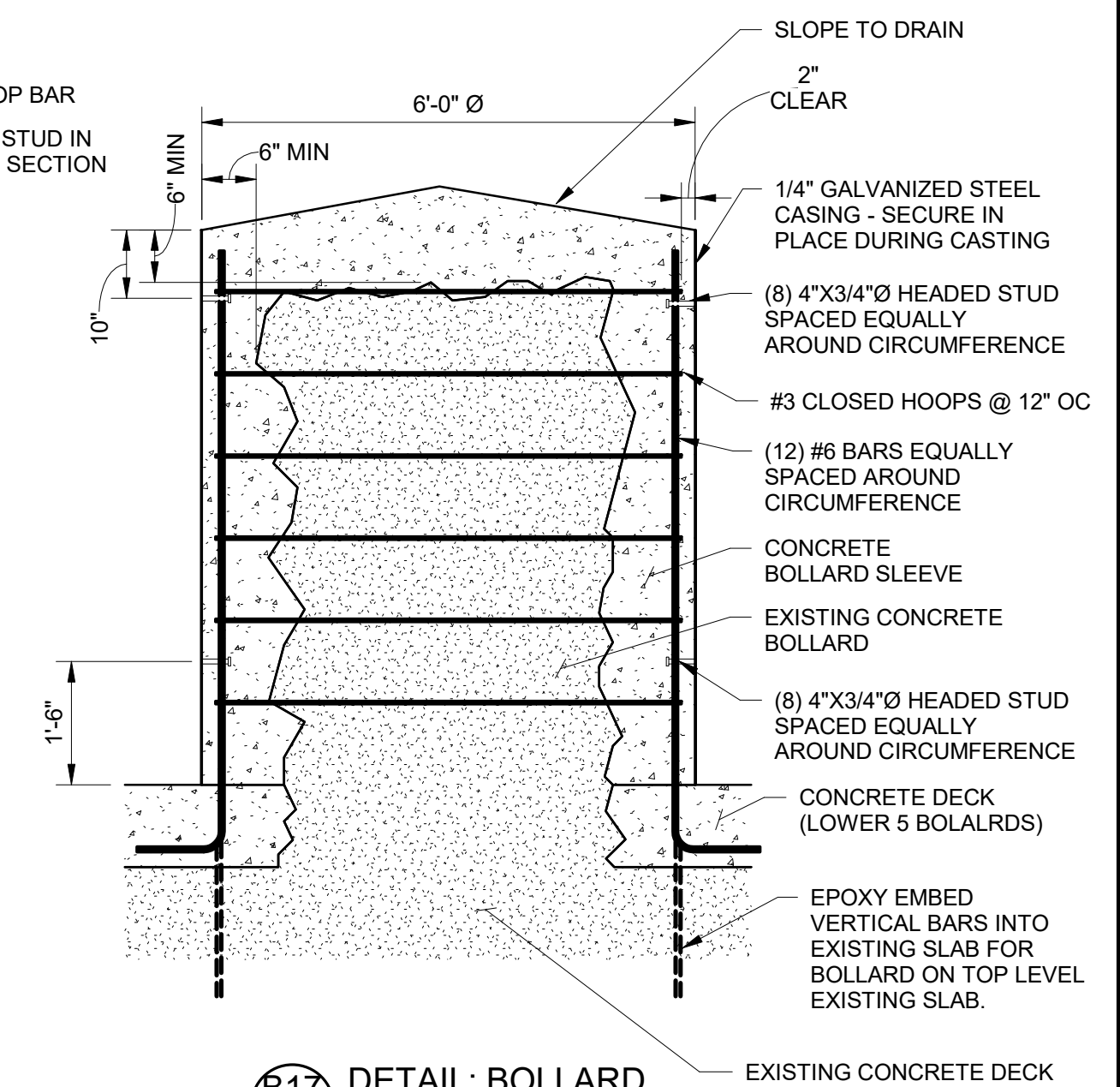

B17 DETAIL: BOLLARD
S-104 1/2" = 1'-0"

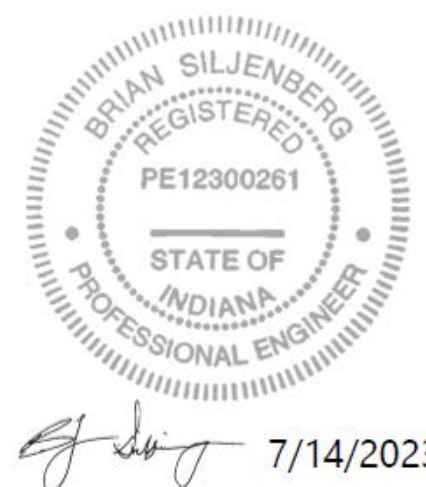

- SHEET NOTES:**
- FINAL SEQUENCING IS THE RESPONSIBILITY OF THE CONTRACTOR AND IS TO BE SUBMITTED FOR REVIEW ACCORDING TO THE SPECIFICATIONS. NO MORE THAN 30'-0" OF RIPRAP ALONG THE DRIVE LINE MAY BE REMOVED AT A TIME.
 - MAXIMUM DIFFERENTIAL OF SHEET PILE WALL FILL STONE AND ARMOR STONE NOT TO EXCEED 13'-0" AT ANY POINT DURING INSTALLATION.
 - FILL STONE TO BE PLACED IN MAXIMUM 1' LIFTS. CONTRACTOR TO BUCKET TAMP EACH LIFT.
 - FILL STONE TO MEET OR EXCEED ELEVATION OF ARMOR STONE AT ALL TIMES.
 - SEE C-303 AND SPECIFICATIONS FOR REQUIREMENTS ON ARMOR STONE REMOVAL.
 - EXISTING ROCK MAY BE PRESENT SUBSURFACE OF LAKE BED. SEE B3/R-001 FOR BEST AVAILABLE EXISTING CROSS SECTION.

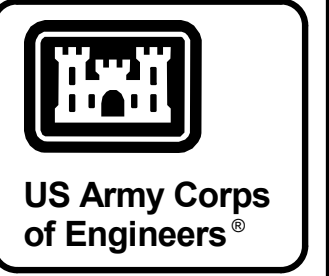

MARK	DESCRIPTION	DATE

DESIGNED BY: K. SEIDLER	ISSUE DATE: JULY 14, 2023
DRAWN BY: B. HOROB	SOLICITATION NO.: W912P623-B-0007
CHECKED BY: B. SILJENBERG	CONTRACT NO.: W912P623-C-XXXX
SUBMITTED BY: P. HINCK	

U.S. ARMY CORPS OF ENGINEERS
CHICAGO DISTRICT
231 S. ASHLEIGH ST., SUITE 1600
CHICAGO, ILLINOIS 60604

BARR
Prairie-Hanson
100 North Parkside Dr
Chicago, IL 60642

MICHIGAN CITY
EAST PIER AND DETACHED BREAKWATER REPAIR - FY23
MICHIGAN CITY, INDIANA

STRUCTURAL - CONCRETE
SECTIONS AND DETAILS

SHEET ID
S-105

CERTIFIED FINAL - READY TO ADVERTISE