



# Generate Wood Products

## *From firewood to high-quality veneer*

Firewood, fence posts, sawlogs, and veneer logs are examples of wood products that can come from woodlots of any size, including your backyard woods.

### **Firewood**

Trees that are crooked, poorly-formed, infested with pests, or that crowd out more desirable trees are recommended candidates for the firewood pile. (See the Backyard Woods Tip Sheet on Help Your Preferred Trees Grow for more information.) Trees that have died and fallen to the ground are also good possibilities for burning in a fireplace or wood stove.

After cutting firewood trees into logs of proper length for burning, a minimum of 6 months of favorable drying

conditions (spring through fall) is needed to “season” the firewood. Splitting the logs hastens the drying process. To dry logs, stack them in a sunny, open, airy, and well-drained location where the moisture will evaporate from the wood. A supporting base of concrete blocks or metal or plastic pipe promotes air circulation and keeps the wood from drawing moisture from the ground. A simple cover to shed rain and snow from the woodpile aids drying.

### **Fence posts**

Some tree species are naturally resistant to decay and insect attack, and can provide long-lasting fence posts. The natural resistance varies from tree to tree and is particularly dependent on the age of the tree. Younger trees have less heartwood and are less resistant.



Stack firewood in a sunny, well-drained location 30 feet or more from your house. Cover your pile to keep out rain and snow.

Be careful to cut posts with a high percentage of heartwood (the darker wood near the center of a tree) since sapwood (the lighter wood near the bark) is easily degraded by fungi and insects. Fence posts from osage-orange, with at least 3 inches of heartwood, and from black locust usually last in the ground for 15 or more years. Posts from cedar, cypress, redwood, and white oak heartwood can last 7 to 15 years. Untreated pine, hickory, red oak, spruce, sweetgum, sycamore, willow, and yellow-poplar posts typically last from 2 to 7 years. In general, where long life of a post is important, it is best to treat posts with preservative.

Posts that have been seasoned are lighter and easier to handle than green, fresh-cut posts. To season posts stack them in “Lincoln log” (crisscross) fashion in columns for 6 to 12 months or more for adequate drying.

## The art of making a wood fire

Needleleaf trees, like pine, spruce, and fir, ignite easily because they are resinous. They burn rapidly with a hot flame; however, a fire built entirely of needleleaf trees burns out quickly and requires frequent attention and replenishment. The denser broadleaf trees such as ash, beech, birch, maple, and oak provide a longer lasting fire. These broadleaf species burn less vigorously and with a shorter flame than do needleleaf trees.

Aroma is best derived from the woods of fruit trees, such as apple and cherry, and nut trees, such as beech, hickory, and pecan. The aroma of their smoke generally resembles the aroma of their fruit.

By mixing logs from needleleaf and broadleaf trees, an easily ignited and long-lasting fire can be created. Later, by adding some fruit or nut woods, a nostalgic wood smoke aroma can be generated.

## Setting Posts

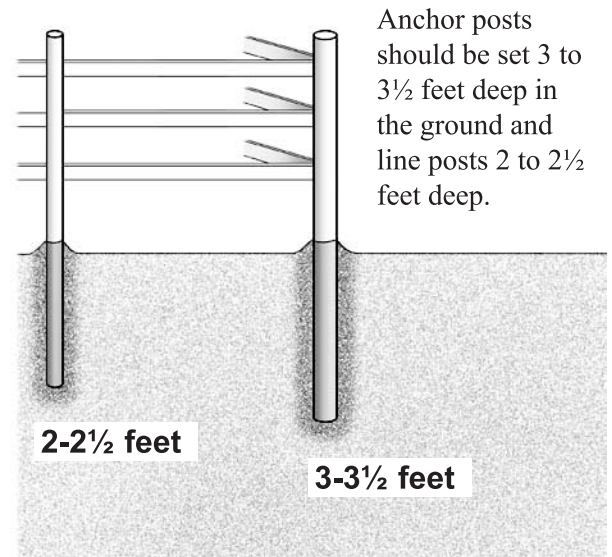

Anchor posts (gate, corner, and end) should be 5 inches in diameter or larger. Line posts should have a minimum diameter of 3 to 3½ inches, although smaller posts are often used. Posts 4 or 5 inches in diameter should be used for barnyards, corrals, and other confined areas, and in sandy or wet soils.

## Sawlogs

Relatively straight trees with one main trunk and a diameter greater than 12 inches can produce lumber for home or commercial use. These trees, often referred to as “sawtimber,” may contain one or more “sawlogs” that can be converted by a sawmill into boards of varying lengths and widths.

If you need rough sawn lumber for a do-it-yourself project, you can often contract with a portable sawmill operator. A portable mill can be brought directly to your woods to convert the logs to boards. The mill operator can be paid in a number of ways—on a unit basis (cost per board foot sawn), a negotiated “shares” agreement (mill operator and woodlot owner divide the lumber output, usually on a percentage basis), or an hourly rate.





A portable mill can convert your backyard woods sawlogs into lumber for do-it-yourself projects.

Sawlogs converted to green (fresh-from-the-saw) lumber can be adequately air dried outdoors for rough construction uses such as sheds, barns, fences, and crates. Successful air-drying is dependent upon warm air temperature, low relative humidity, and good circulation of the air within the pile. The temperature and relative humidity vary with

the region of the country and the season of the year. The number of months per year of good air-drying conditions increases from north to south in the United States.

Green lumber should be stacked on a foundation to elevate the lumber pile 12 inches or more off the ground and to exhaust air that has moved downward through the pile. Wood “sleepers” or posts or piers made from wood, concrete, cement building blocks, or masonry can function as a foundation. Timber bolsters (supporting beams) should be placed directly on the foundation. The bolsters must be perfectly aligned with the spacers (called stickers). Stickers should be 1 to 2 inches wide, a uniform thickness (3/4 to 1 inch), as long as the pile is wide, and made from straight, dry lumber. Stickers should be distributed across the stack every 12 to 24 inches to separate each course of lumber and promote good air flow on all sides of each board. Also, the ends of each board, if possible, should be supported by a sticker (above and below) to limit end checking (splitting) and reduce warp.

A good cover is essential for air-drying of lumber. A water-tight cover protects the top courses of lumber

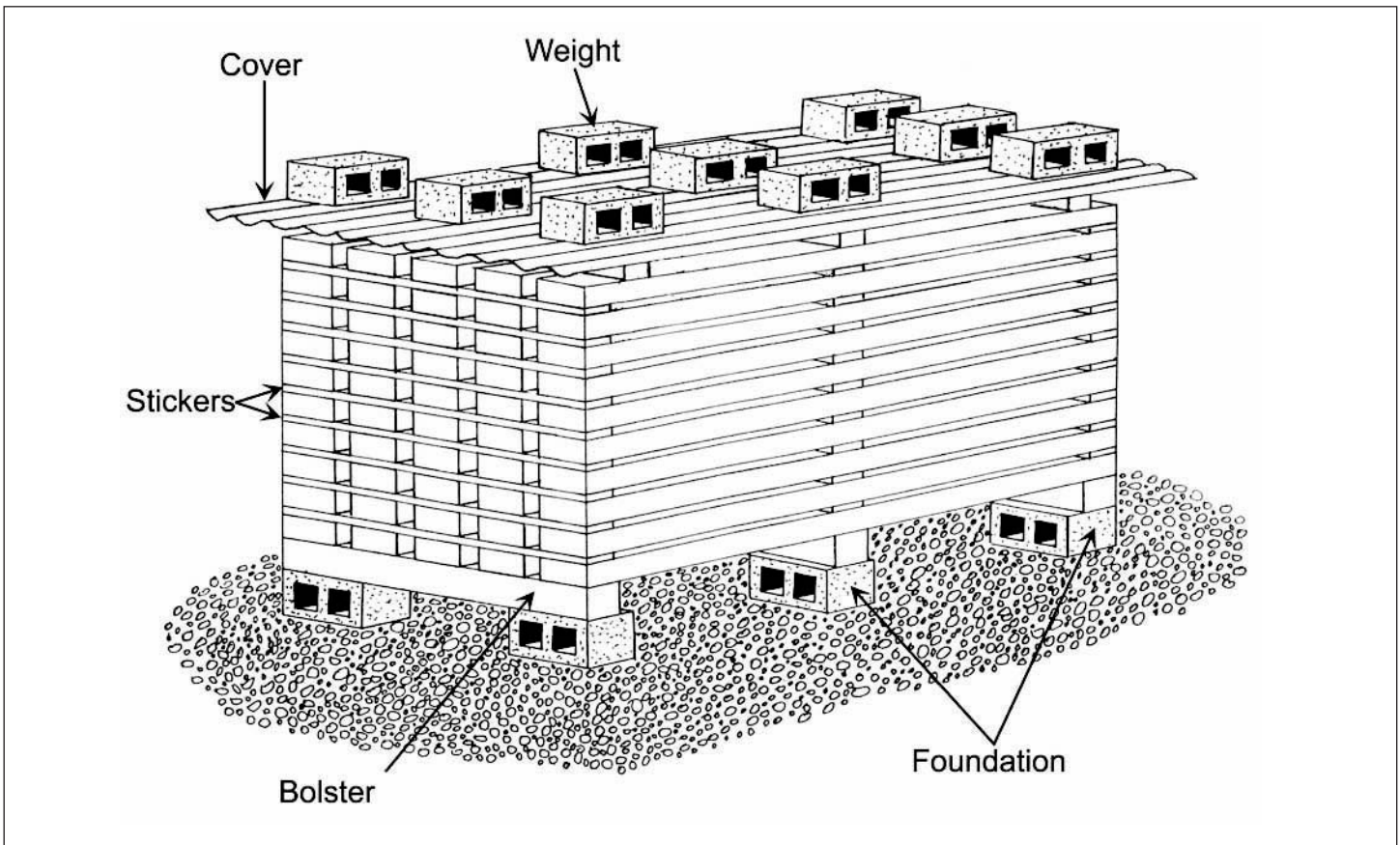

Lumber piled properly for drying should have a solid foundation, stickers aligned vertically with the bolsters, a water-tight cover, and heavy weights on the top of the pile.

---

from rain, snow, and direct sunshine. The top courses of uncovered piles are subject to warping and checking. Unprotected piles also permit moisture to penetrate the pile, which slows drying and increases the chance of staining. Concrete blocks, old timbers, or other heavy objects should be placed on the cover to keep the lumber flat and straight.

Since different wood species and lumber thicknesses dry at different rates, all lumber in a pile ideally should be of the same species and thickness. For example, in the central United States, 1-inch thick yellow-poplar lumber requires about 1 to 3 months during summer to dry to 20 percent moisture content, whereas 2-inch thick white oak requires about 6 to 9 months to dry between spring and fall.

Lumber for indoor use such as furniture, cabinets, and flooring is typically kiln-dried to 6-8 percent moisture content. Kiln operators are often available to do custom lumber drying for woodlot owners. The 6-8 percent moisture content can also be achieved by placing the lumber in a heated room with low relative humidity; however, custom kiln drying is probably a better option if available.

### **Veneer**

Black walnut, red and white oak, sugar maple, and black cherry are prized for the high quality of veneer—thin sheets of wood—that can be manufactured from them. Veneer trees are typically large, straight broadleaf trees, greater than 20 inches in diameter at a point 4½ feet above the ground, with the first 9 feet of the trunk completely free of limbs, branch stubs, scars, wounds, foreign material such as nails and fencing, and other defects. Sometimes, one or two high quality veneer trees are enough to attract the interest of a timber buyer. Do not attempt to fell a veneer quality tree; leave the job for a professional tree harvester, and do not sell the veneer tree to a buyer until you have gotten advice from a professional forester.

### **Other wood products**

Local markets often exist for unique or niche markets. For example, trees for cabin logs are in demand in selected areas for home construction. Large needleleaf trees, in certain localities, may be sold for utility poles. If a paper mill is nearby, you may be able to market both broadleaf and needleleaf trees as pulpwood. There may also be a local market for special forest products from your backyard woods, such as holiday boughs, mushrooms, berries, and fruit. (See the Backyard Woods Tip Sheet on Grow and Collect Special Forest Products for more information.)

### **Marketing products from your woods**

Landowners with small acreages should consider selling products jointly with neighboring landowners. The larger the quantity of product offered for sale the more interest there will be from buyers and greater the potential economic return. Never accept an offer from the first potential buyer, especially an unsolicited offer. Always seek bids from a number of buyers.

The assistance of a professional forester is recommended whenever you sell timber. A forester can assist you (and your neighbors) in determining the quantity and quality of product in your woods, explain the different types of sales (lump-sum versus sale-by-unit), assist in the preparation of a timber sale contract, advertise the sale, help with selecting a buyer, and monitor the harvesting. A professional forester can also advise you on how a tree harvest will affect the long-term growth and health of your woods.

### **In the Forest**

Together with other nonindustrial private forest landowners, you own 57 percent of the commercial forest land in the United States. With a trend of declining harvests on public forest lands, demand for forest products from private lands is increasing to meet the needs of a growing U.S. population. Each year, one American uses about 600 pounds of paper, plus the lumber equivalent of a 100-foot tall tree. Annual growth of U.S. commercial forests fortunately exceeds harvests and mortality by 33 percent. In addition to the millions of trees that regenerate naturally every year, on average almost 5 million new trees are planted each day in the U.S. Not only are forests renewable, but the growth of wood is powered by environmentally friendly solar energy. Also, the manufacture of wood products requires significantly less fossil-fuel energy consumption than does the manufacture of substitute products from nonrenewable sources such as steel, plastic, and aluminum.

## Bibliography

Edmonds, R.L.; Wells, G.D.; Gilman, F.E.; Knowles, S.W.; Engalichev, N. 1988. Lumber from local woodlots. NRAES-27. Ithaca, NY: Northeast Regional Agricultural Engineering Service, Cornell University; 42 p.

Forest Products Laboratory. 1999. Air drying of lumber. Gen. Tech. Rep. FPL-GTR-117. Madison, WI: USDA Forest Service; 62 p.

Levi, Michael P. 1974. Fence posts for farm and home. Folder 320. Raleigh, NC: Agricultural Extension Service, North Carolina State University; 11 p.

Milton, F. Thomas; Hendricks, Lewis T.; Brevik, Theodore J.; Stegmeir, Paul B. 1979. Heating the home with wood. Ext. Bulletin 436. St. Paul, MN: Agricultural Extension Service, University of Minnesota; 31 p.

Vermont Department of Forests, Parks, and Recreation. 2001. Drying native lumber. Waterbury, VT; 5 p.

Wengert, Gene. 2002. Stacking and air drying basics. Independent Sawmill and Woodlot Management 6(26): 19-22.

A Cooperative Project of:



[www.fnr.purdue.edu/inwood/ifwoa%20home.htm](http://www.fnr.purdue.edu/inwood/ifwoa%20home.htm)



[www.arborday.org/backyardwoods](http://www.arborday.org/backyardwoods)



[www.agriculture.purdue.edu/fnr/Extension/forestry.htm](http://www.agriculture.purdue.edu/fnr/Extension/forestry.htm)



USDA Forest Service  
NORTHEASTERN AREA  
State and Private Forestry  
[www.na.fs.fed.us](http://www.na.fs.fed.us)



[www.in.gov/dnr/forestry](http://www.in.gov/dnr/forestry)



National Association of  
Conservation Districts