

Basic Training Accessibility For Indiana Communities

ADA & Title VI Program Level 1

Meet your INDOT compliance staff

Erin Hall, JD: Director Interagency Relations & Compliance

Ehall2@indot.in.gov

Kimberly Ray, MBA: Title VI Program Manager

KiRay@indot.in.gov

Will Gay: Subrecipient Compliance Auditor

wgay@indot.in.gov

**Barbara Malone, JD: Investigations, Policy, ADA Technical
Subject Matter Expert & Legal Research**

BaMalone@indot.in.gov



Aging Populations Drive the Need for Access.

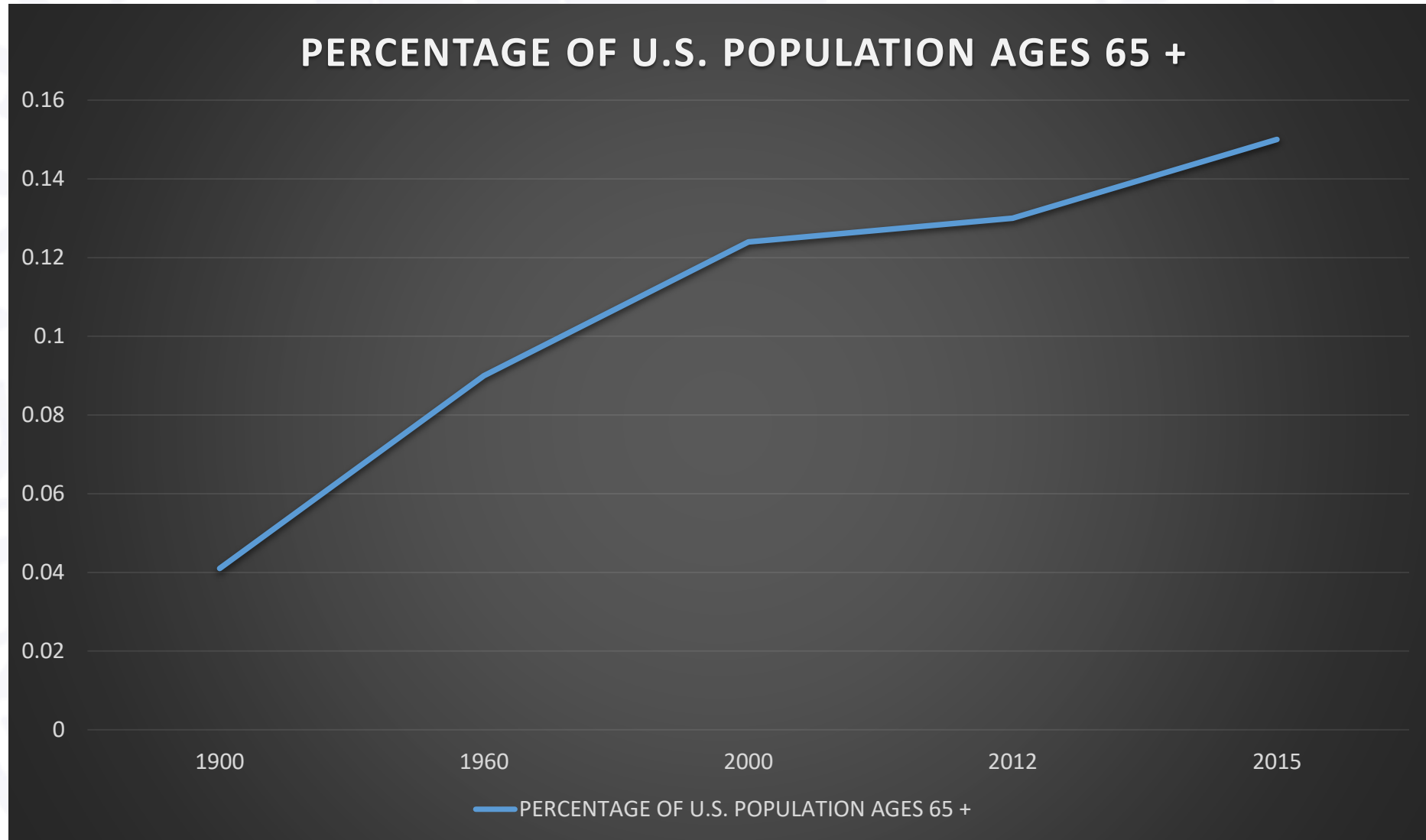

Best Case Scenario:

**1 in 5 of us
Will be disabled**

Accessibility Matters:

You plan to live:

- Retirement Accounts
- Annuities
- Home
- Life Insurance
- Health Insurance

Plan somewhere *liveable*.



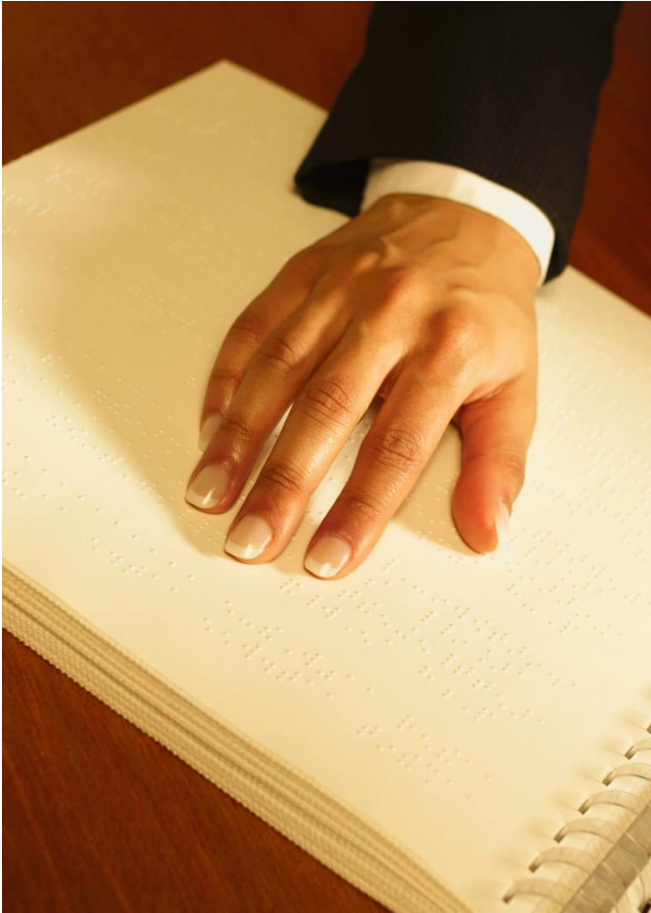

Section 504 of the Rehabilitation Act of 1973:

“No qualified handicapped person shall, solely, by reason of his handicap, be excluded from participating in, be denied the benefits of, or be subjected to discrimination under **any program or activities that receives or benefits** from Federal financial assistance.”

Americans with Disabilities Act

- Title II Applies to all **public entities**
- Requires provision of program access and effective communication
- Includes public transportation
- Enforced by U.S. Dept. of Justice

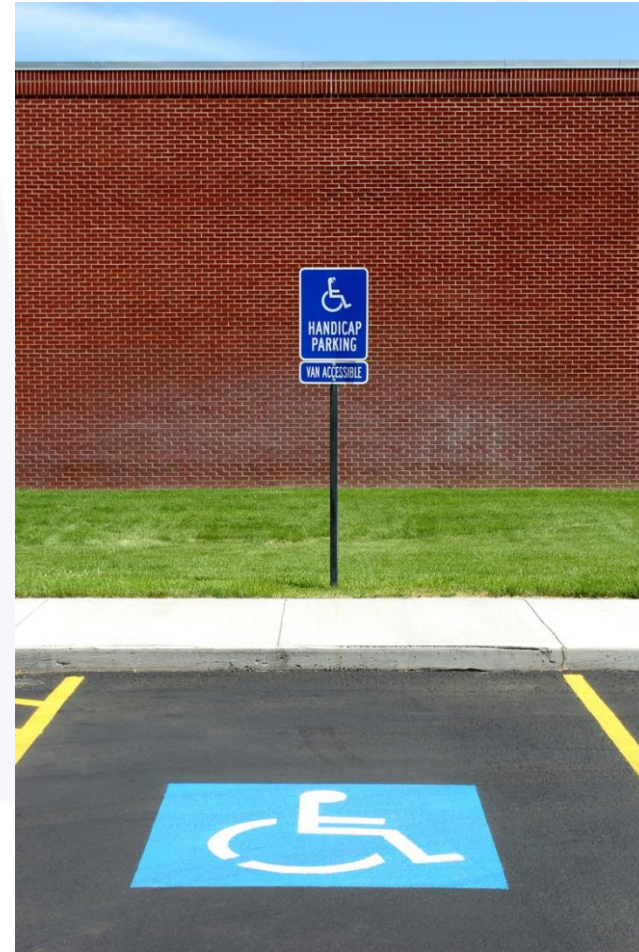

Goals of the ADA

- Equal opportunity
- Full participation
- Independence
- Economic self-sufficiency



IMPLEMENTATION PLANNING MODEL:

- PROGRAM ANALYSIS / BARRIER IDENTIFICATION
- GOALS / PRIORITIZATION
- “LIVE” ACTION PLAN
 - SCHEDULE
 - BUDGET
- DATA COLLECTION & ANALYSIS
- REPORT
- REVIEW
- REPEAT

Implementation Planning – ADA Transition Plan:

1. Identify a Coordinator
2. Understand Operations
3. Engage Champions as Liaisons
4. Public Involvement Early & Often
5. Develop Key / Required Policies
6. Develop a Plan
7. **DO THE WORK** of implementation
8. Review Results
9. Repeat



Public Agency Accessibility Responsibilities:

- Designate an ADA Coordinator
- Develop, Post & Implement a Section 504 Policy
- Ensure all programs are accessible
- Design & Build accessible facilities
- Implement a Complaint Policy
- Evaluate Programs & Facilities for Accessibility (Self-evaluation)
- Solicit Public Involvement
- Identify barriers to program and facility access
- Allocate a budget & set a schedule for removal of barriers
- Develop, Post & Implement an ADA Transition Plan
- Update the plan regularly – keep it living.
- Monitor compliance on an ongoing basis



Where do I start? - PREVIEW!

1. Decide WHO (see Roadmap to ADA Compliance)
2. Use Templates to develop policies – the “low hanging fruit”
3. Learn & understand the requirements & how they relate to your agency
4. Adopt a grievance procedure early to “stop the gap”
5. Train your employees before you build a team
6. Identify liaisons / people who will work with you
7. Conduct a self-evaluation
8. Obtain public input & prioritize
9. Adopt a budget
10. Develop an ADA Transition Plan



Section 504 Nondiscrimination Policy

- The subrecipient must develop and publish an ADA Accessibility Policy
- INDOT's ADA Notice of Nondiscrimination can be found here: The policy must be signed or adopted by the subrecipient to be made official.
- The policy should be published and posted.
- The policy should be included in the ADA Transition Plan.



Designating an ADA Coordinator

- An ADA Coordinator must be designated.
- This individual must be identified by name.
- Their contact information must be provided.
- They must be an employee of the entity



Self-Evaluation

- The ADA requires that ALL programs and facilities, including everything from websites, public outreach policies, to city buildings, parks, and sidewalks be evaluated for ADA compliance.
- Measuring all features of facilities and maintaining a record is required.
- Assessing programs and identifying areas of noncompliance is required.
- The self-evaluation will form the basis for the prioritization schedule in the ADA transition plan.

Acronyms

- ADA
 - Americans with Disabilities Act
- ADAAG
 - Americans with Disabilities Act Accessibility Guidelines for Buildings and Facilities
- APS
 - Accessible Pedestrian Signal
- PAR
 - Public Access Route
- PROW
 - Public Rights of Way
- PROWAG
 - Public Rights of Way Accessibility Guidelines



Purpose of Self-Evaluation



- To identify current compliance efforts
 - Most effective way to ensure compliance
- Create a baseline to identify and monitor progress

Elements of a Transition Plan

- **ADA Self-Evaluation**
 - A comprehensive detailed description of the location of physical obstacles affecting accessibility that must be removed
- **Recommendations for making the facilities accessible**
 - Detailed description of proposed action to remedy compliance issues



- Self-evaluations and transition plans have been required since 1973 under Section 504 of the Rehabilitation Act
- Reiterated in 1990 with the enactment of the Americans with Disabilities Act (ADA)
- Removal of physical barriers was due to be completed by January 26, 1995



Who should conduct the survey?



- Easiest to conduct using a team of 2-3 people

What tools are needed?

- Measuring Tape
 - Metal (for durability)
 - At least 25 feet long (to measure long distances)
 - Easy to read (to ensure accurate data)
 - Essential tool because many requirements concern width, height or depth of various features





- Smart Level (digital/electronic)
 - 2.0 foot level per standards
 - Must be calibrated each day before using and recalibrated if dropped
 - Hand broom is helpful for clearing debris!

Curb Ramp Design

- Perpendicular curb ramp

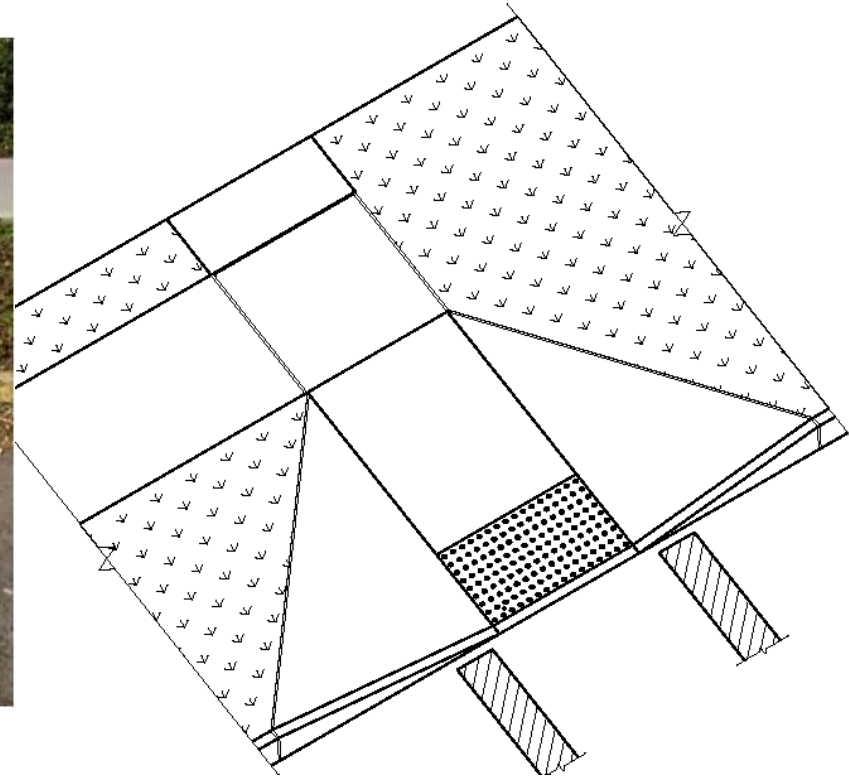

PROWAG R304.2 and R304.5

Curb Ramp Design

- Parallel curb ramp

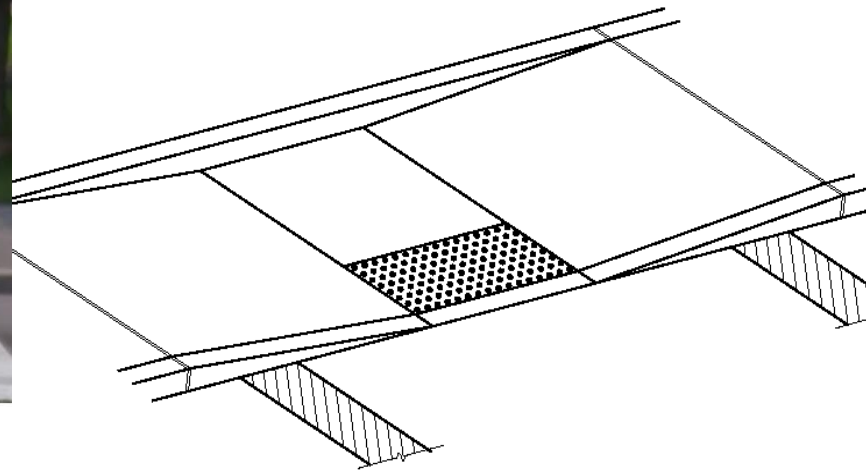

PROWAG R304.3 and R304.5

Curb Ramp Design

- Blended transition curb ramp

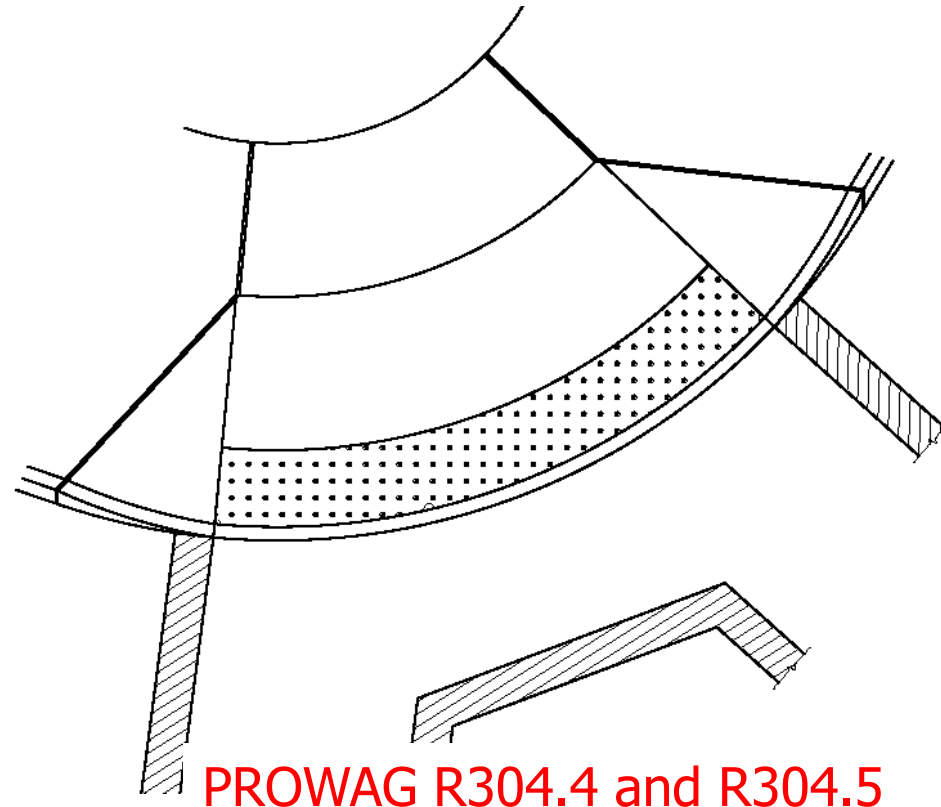

Curb Ramp Design

- Depressed corner curb ramp

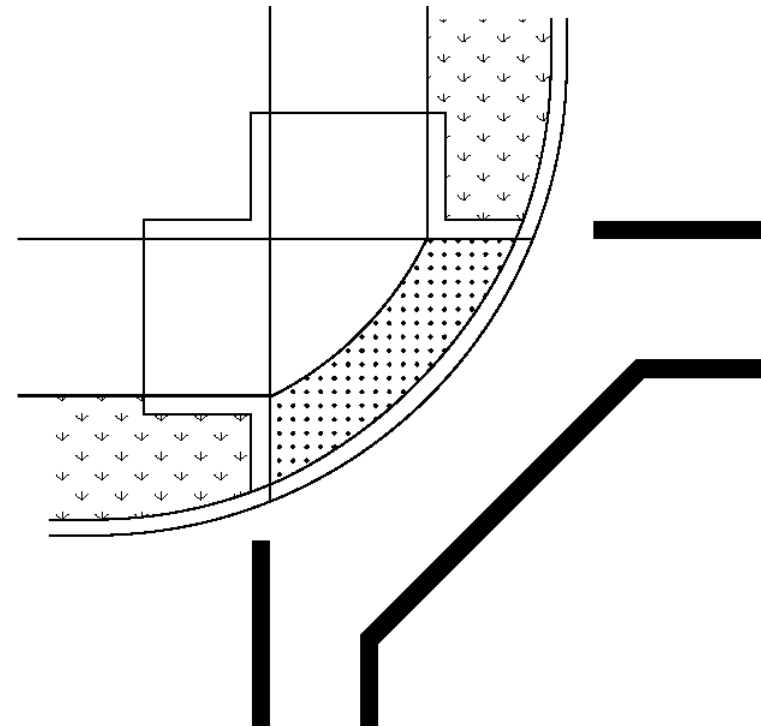

Same as Parallel Curb Ramp

Curb Ramp Design

- Diagonal curb ramp

Prohibited in New Construction

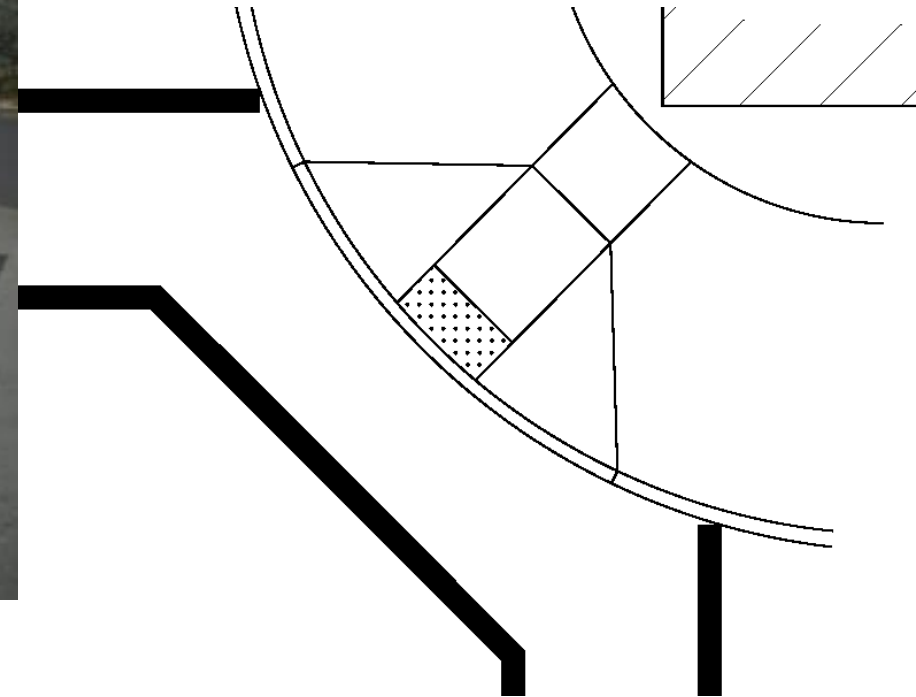

Same as Perpendicular Curb Ramp

Curb Ramp Priority

- Perpendicular curb ramp – BEST (**8.33%**)
- Parallel curb ramp (8.33%)
- Blended transition curb ramp (**5% or 2%**)
- Depressed corner, and (**5%**)
- Diagonal curb ramp (Prohibited for New Construction) (**8.33%**)

Consider maintenance: will the ramp get driven over? What is the effect on drainage? Safety?



Curb Ramps: "201"

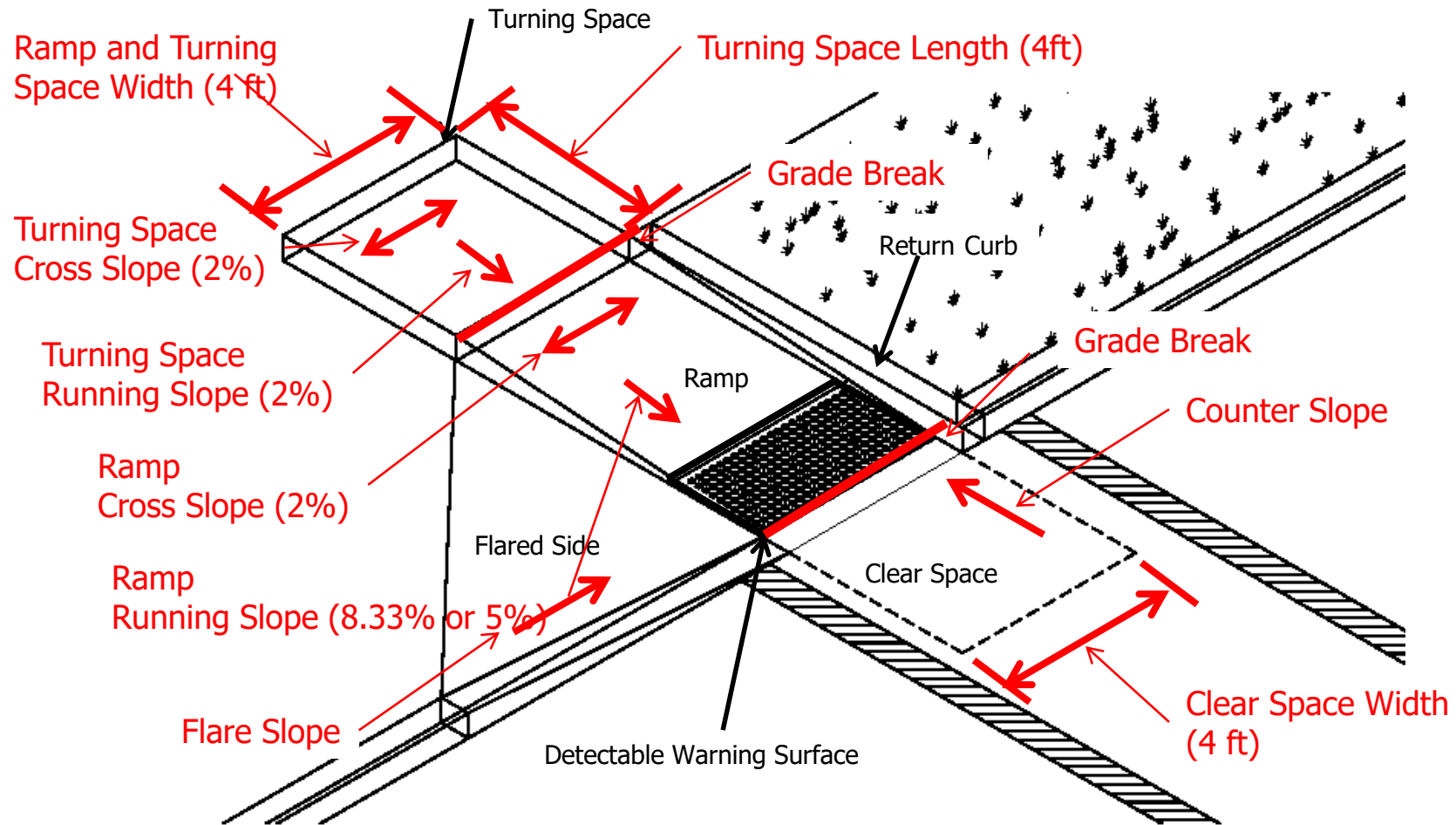

■ Crosswalks

- Whether crosswalks are present at any or all crossings
- If present, the width, type, if there are islands



Detectable Warnings

- Detectable Warnings are designed to be felt underfoot or with a cane by people who are blind or have low vision, to alert them to hazards – should extend whole width of the ramp and be part of a flush transition.



Islands/Medians



- Islands –Are there islands IN the pedestrian path (even if they block it)
- Pedestrian Signals
 - Whether visual and accessible pedestrian signals are present and if they are APS (Accessible Pedestrian Signals)



Pushbuttons



- Is the tactile arrow in line with the crosswalk direction?
- Is the pedestrian push button at least 2 inches in diameter?
- Is the push button unobstructed?
- 42" target ("shall" U.S. access board)
- www.Apsguide.org
- <https://www.access-board.gov/guidelines-and-standards/streets-sidewalks/public-rights-of-way/background/access-advisory-committee-final-report/x02-5-pedestrian-street-crossings>

Pedestrian Access Route (PAR)

- Pedestrian Access Route (PAR)
 - Width is measured from the back of the curb or buffer to the outside edge of the sidewalk

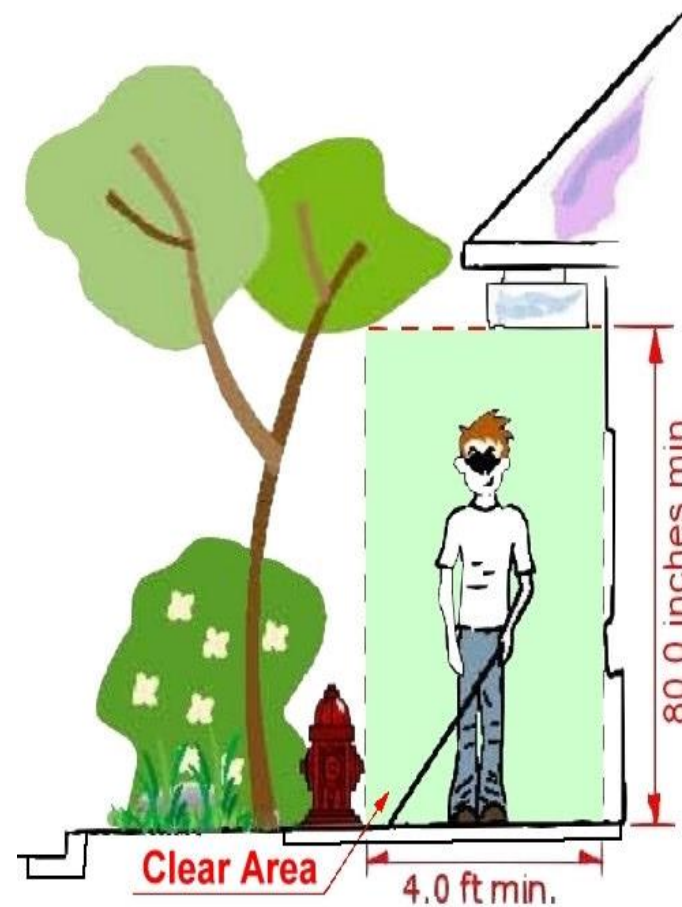

■ Sidewalk Zone System

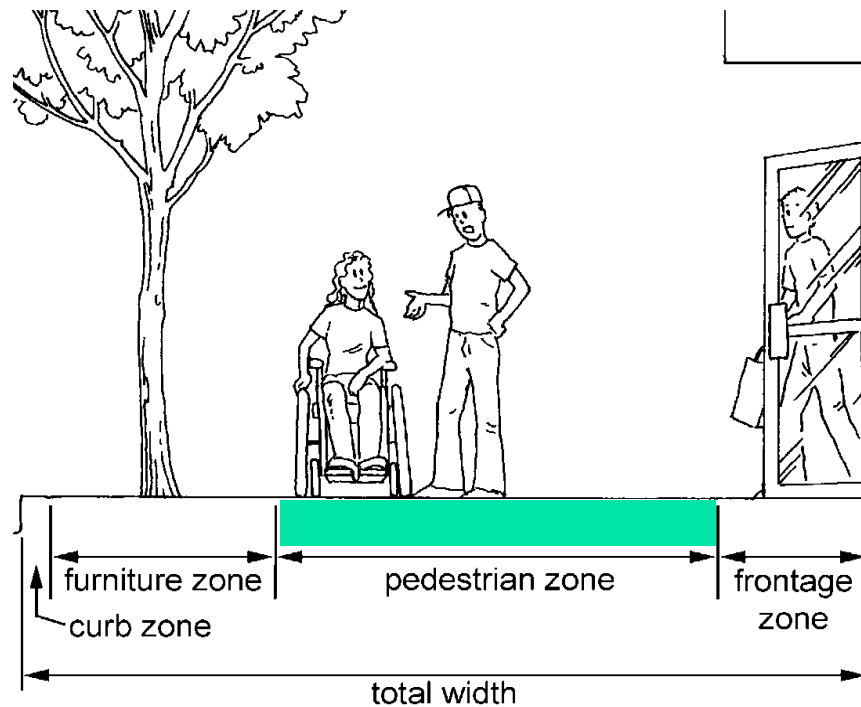

Protruding objects

- Protruding Objects
 - Objects above 27 inches and below 80 inches are not detectable

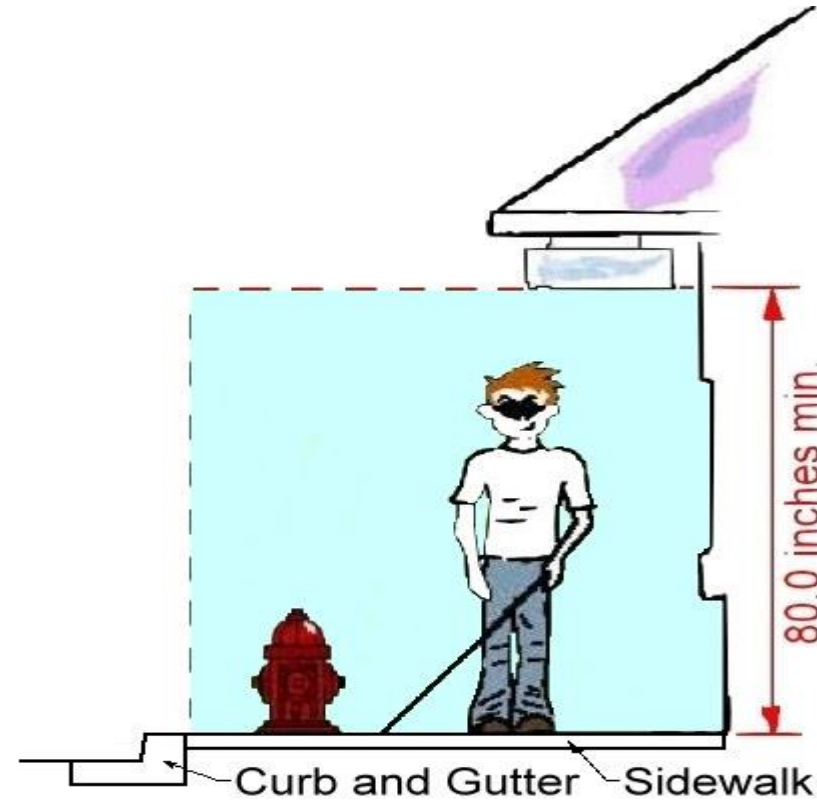

Where to start inventory / updates?

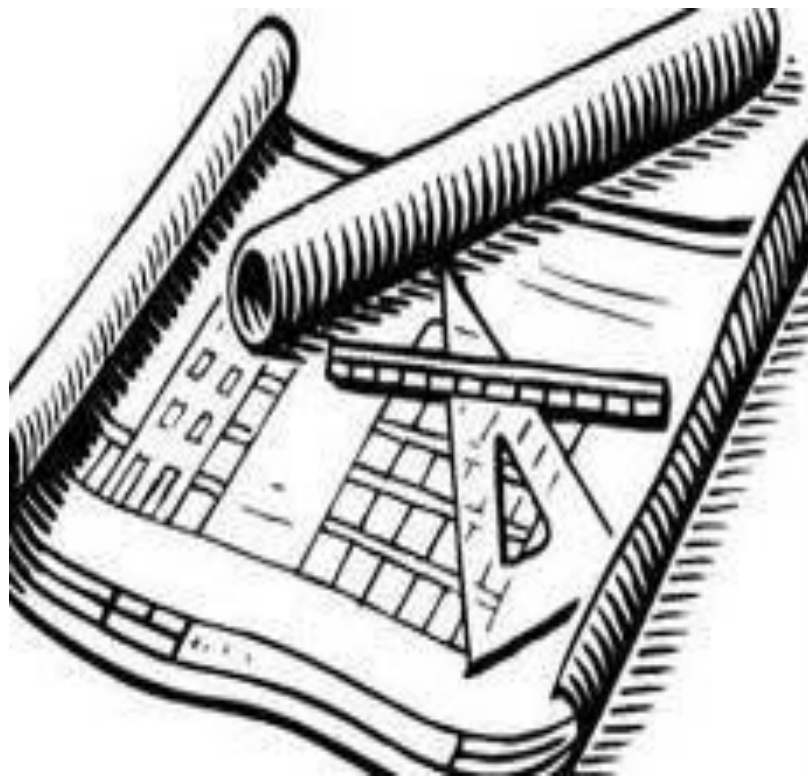

- Recent projects
- High pedestrian traffic areas
- Areas near facilities frequently used by pedestrians

ADA Transition Plan

- Identify your ADA Coordinator by name and include contact information
- Include the ADA policy
- Include the grievance procedure for ADA complaints
- Include the ADA self-evaluation results (for programs and facilities)
- Identify the design standards for all facilities (buildings & roadway assets)
 - ADAAG for Architectural, including ramps leading up to buildings
 - PROWAG for PUBLIC RIGHT-OF-WAY Assets

ADA Transition Plan

Include a prioritization schedule for remediating assets and programs that are not ADA compliance with a means of identifying your community's commitment to complete the schedule by

identifying either (if not both) of the following:

- The completion date for each item on the schedule or
- A budget to be applied to the items on the prioritization schedule together with cost estimates for their remediation.

ADA Transition Plan

Commitment Date Prioritization Example:

The Ramp leading up to the rear of the court house is slightly too steep. Our community plans to address this by replacing the ramp not later than 2020. Since the ramps is only slightly too steep, we are targeting other priorities first.

Budget Prioritization Example:

Priority List:

1. The pedestrian signal at Main street and North Street is inoperable. It requires maintenance and an upgrade to an accessible pushbutton. Estimated Cost to repair is \$8,500.00. (est. 2018)
2. The Ramp leading up to the courthouse is slightly too steep. The ramps is 15 feet long and needs to be replaced at an estimated cost of \$18,000 (est. 2020)

Our community is committed to spending \$10,000 per year on ADA-specific improvements and will improve highest priority items first.

More about Transition Plans

- Keep the plan simple.
- Do include your inventory and prioritization schedule with the plan.
- It is not acceptable to have all of the plan components but not have them all pulled together in one place to form an ADA Transition Plan.
- It should also be a living document, updated on an ongoing basis as work is completed.

Transition Plan Checklist:

- Identifies ADA Coordinator by name with contact information
- Includes Section 504 Policy
- Includes Complaint policy, procedure & compliant form
- Developed with public input & identifies input method
- Discusses public meetings, all programs & activities, accessibility aids, etc.
- Identifies design standards used
- States how often the plan is renewed (2-3 years ideal)
- Includes self-inventory
- Prioritization schedule with completion dates
- Budget
- Training

