

Indiana Department of Transportation



CERTIFIED TECHNICIAN PROGRAM
TRAINING MANUAL FOR



Concrete Paving



2024 Revision

MATH REFERENCES

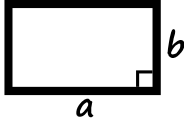
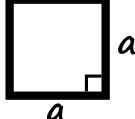
1 foot = 12 inches 1 square foot = 144 square inches 1 cubic foot = 1728 cubic inches
 3 feet = 1 yard 9 square feet = 1 square yard 27 cubic feet = 1 cubic yard
 5280 feet = Mile 1760 yards = 1 mile 1 acre = 4840 square yards

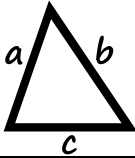
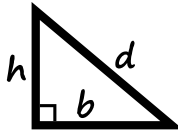
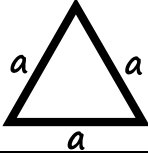
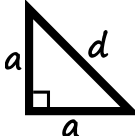
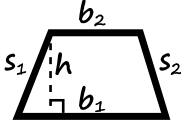
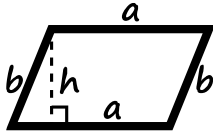
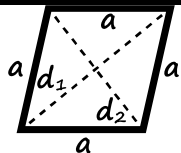
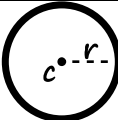
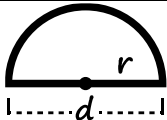
| | | | |
|--------------------------|---|---------------------------|---|
| Rectangle |  | Square |  |
| Perimeter | $2(a + b)$ | Perimeter | $4a$ |
| Area | $a \times b$ | Area | a^2 |
| Triangle |  | Triangle (any) |  |
| Perimeter | $a + b + c$ | Area by sides (no height) | $s = \frac{1}{2}(a + b + c)$ |
| Area | $\frac{1}{2}(b \times h)$ | | $A = \sqrt{s(s - a)(s - b)(s - c)}$ |
| Right Triangle |  | Equilateral Triangle |  |
| Perimeter | $b + h + d$ | Perimeter | $3a$ |
| Area | $\frac{1}{2}(b \times h)$ | Area | $\frac{\sqrt{3}}{4}a^2$ |
| Isosceles Right Triangle |  | Trapezoid |  |
| Perimeter | $2a + d$ | Perimeter | $b_1 + b_2 + s_1 + s_2$ |
| Area | $\frac{1}{2}a^2$ | Area | $h \times \frac{b_1 + b_2}{2}$ |
| Parallelogram |  | Rhombus |  |
| Perimeter | $2(a + b)$ | Perimeter | $4a$ |
| Area | $a \times h$ | Area | $\frac{d_1 \times d_2}{2}$ |
| Circle |  | Semicircle |  |
| Perimeter | $2\pi r$ | Perimeter | $\pi r + 2r$ |
| Area | πr^2 | Area | $\frac{\pi r^2}{2}$ |

AREA OF A CIRCULAR SEGMENT

$$\text{Area} = C \times b \times \text{coefficient}$$

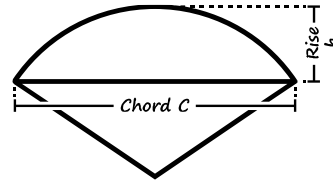

| Coefficient | $\frac{b}{C}$ |
|-------------|---------------|
| 0.66667 | 0.00218 |
| 0.66668 | 0.00436 |
| 0.66669 | 0.00655 |
| 0.66671 | 0.00873 |
| 0.66673 | 0.01091 |
| 0.66676 | 0.01309 |
| 0.66679 | 0.01528 |
| 0.66683 | 0.01746 |
| 0.66687 | 0.01965 |
| 0.66692 | 0.02183 |
| 0.66697 | 0.02402 |
| 0.66703 | 0.02620 |
| 0.66710 | 0.02839 |
| 0.66717 | 0.03058 |
| 0.66724 | 0.03277 |
| 0.66732 | 0.03496 |
| 0.66740 | 0.03716 |
| 0.66749 | 0.03935 |
| 0.66759 | 0.04155 |
| 0.66769 | 0.04374 |
| 0.66779 | 0.04594 |
| 0.66790 | 0.04814 |
| 0.66802 | 0.05035 |
| 0.66814 | 0.05255 |
| 0.66826 | 0.05476 |
| 0.66839 | 0.05697 |
| 0.66853 | 0.05918 |
| 0.66867 | 0.06139 |
| 0.66882 | 0.06361 |
| 0.66897 | 0.06583 |
| 0.66913 | 0.06805 |
| 0.66929 | 0.07027 |
| 0.66946 | 0.07250 |
| 0.66964 | 0.07473 |
| 0.66981 | 0.07696 |
| 0.67000 | 0.07919 |
| 0.67019 | 0.08143 |
| 0.67039 | 0.08367 |
| 0.67059 | 0.08592 |
| 0.67079 | 0.08816 |
| 0.67101 | 0.09041 |
| 0.67122 | 0.09267 |
| 0.67145 | 0.09493 |
| 0.67168 | 0.09719 |
| 0.67191 | 0.09946 |

| Coefficient | $\frac{b}{C}$ |
|-------------|---------------|
| 0.67215 | 0.10173 |
| 0.67240 | 0.10400 |
| 0.67265 | 0.10628 |
| 0.67291 | 0.10856 |
| 0.67317 | 0.11085 |
| 0.67344 | 0.11314 |
| 0.67372 | 0.11543 |
| 0.67400 | 0.11773 |
| 0.67429 | 0.12004 |
| 0.67458 | 0.12235 |
| 0.67488 | 0.12466 |
| 0.67519 | 0.12698 |
| 0.67550 | 0.12931 |
| 0.67582 | 0.13164 |
| 0.67614 | 0.13397 |
| 0.67647 | 0.13632 |
| 0.67681 | 0.13866 |
| 0.67715 | 0.14101 |
| 0.67750 | 0.14337 |
| 0.67786 | 0.14574 |
| 0.67822 | 0.14811 |
| 0.67859 | 0.15048 |
| 0.67897 | 0.15287 |
| 0.67935 | 0.15525 |
| 0.67974 | 0.15765 |
| 0.68014 | 0.16005 |
| 0.68054 | 0.16246 |
| 0.68095 | 0.16488 |
| 0.68136 | 0.16730 |
| 0.68179 | 0.16973 |
| 0.68222 | 0.17216 |
| 0.68265 | 0.17461 |
| 0.68310 | 0.17706 |
| 0.68355 | 0.17952 |
| 0.68401 | 0.18199 |
| 0.68448 | 0.18446 |
| 0.68495 | 0.18694 |
| 0.68543 | 0.18943 |
| 0.68592 | 0.19193 |
| 0.68642 | 0.19444 |
| 0.68692 | 0.19696 |
| 0.68743 | 0.19948 |
| 0.68795 | 0.20201 |
| 0.68848 | 0.20456 |
| 0.68901 | 0.20711 |

| Coefficient | $\frac{b}{C}$ |
|-------------|---------------|
| 0.68956 | 0.20967 |
| 0.69011 | 0.21224 |
| 0.69067 | 0.21482 |
| 0.69123 | 0.21741 |
| 0.69181 | 0.22001 |
| 0.69239 | 0.22261 |
| 0.69299 | 0.22523 |
| 0.69359 | 0.22786 |
| 0.69420 | 0.23050 |
| 0.69482 | 0.23315 |
| 0.69545 | 0.23582 |
| 0.69608 | 0.23849 |
| 0.69673 | 0.24117 |
| 0.69738 | 0.24387 |
| 0.69805 | 0.24657 |
| 0.69872 | 0.24929 |
| 0.69941 | 0.25202 |
| 0.70010 | 0.25476 |
| 0.70080 | 0.25752 |
| 0.70151 | 0.26028 |
| 0.70223 | 0.26306 |
| 0.70297 | 0.26585 |
| 0.70371 | 0.26866 |
| 0.70446 | 0.27148 |
| 0.70522 | 0.27431 |
| 0.70600 | 0.27715 |
| 0.70678 | 0.28001 |
| 0.70758 | 0.28289 |
| 0.70838 | 0.28577 |
| 0.70920 | 0.28868 |
| 0.71003 | 0.29159 |
| 0.71087 | 0.29452 |
| 0.71172 | 0.29747 |
| 0.71258 | 0.30043 |
| 0.71345 | 0.30341 |
| 0.71434 | 0.30640 |
| 0.71524 | 0.30941 |
| 0.71615 | 0.31243 |
| 0.71707 | 0.31548 |
| 0.71800 | 0.31854 |
| 0.71895 | 0.32161 |
| 0.71991 | 0.32470 |
| 0.72088 | 0.32781 |
| 0.72187 | 0.33094 |
| 0.72287 | 0.33409 |

| Coefficient | $\frac{b}{C}$ |
|-------------|---------------|
| 0.72388 | 0.33725 |
| 0.72491 | 0.34044 |
| 0.72595 | 0.34364 |
| 0.72701 | 0.34686 |
| 0.72808 | 0.35010 |
| 0.72916 | 0.35337 |
| 0.73026 | 0.35665 |
| 0.73137 | 0.35995 |
| 0.73250 | 0.36327 |
| 0.73364 | 0.36662 |
| 0.73480 | 0.36998 |
| 0.73598 | 0.37337 |
| 0.73717 | 0.37678 |
| 0.73838 | 0.38021 |
| 0.73960 | 0.38366 |
| 0.74084 | 0.38714 |
| 0.74210 | 0.39064 |
| 0.74337 | 0.39417 |
| 0.74466 | 0.39772 |
| 0.74597 | 0.40129 |
| 0.74730 | 0.40489 |
| 0.74865 | 0.40852 |
| 0.75001 | 0.41217 |
| 0.75140 | 0.41585 |
| 0.75280 | 0.41955 |
| 0.75422 | 0.42328 |
| 0.75566 | 0.42704 |
| 0.75713 | 0.43083 |
| 0.75861 | 0.43464 |
| 0.76011 | 0.43849 |
| 0.76164 | 0.44236 |
| 0.76318 | 0.44627 |
| 0.76475 | 0.45020 |
| 0.76634 | 0.45417 |
| 0.76795 | 0.45817 |
| 0.76959 | 0.46220 |
| 0.77125 | 0.46626 |
| 0.77293 | 0.47035 |
| 0.77463 | 0.47448 |
| 0.77636 | 0.47865 |
| 0.77812 | 0.48284 |
| 0.77990 | 0.48708 |
| 0.78171 | 0.49135 |
| 0.78354 | 0.49566 |
| 0.78540 | 0.50000 |

MANUAL DISCLAIMER

The references in this manual are reflective of the 2024 INDOT Standard Specifications. The material covered herein is for training purposes only. The Standard Specifications, Contract Information Book, General Instruction to Field Employees, and Construction Memos should be consulted for determining the current inspection procedures for a given contract. On-site procedures, field tests, and other operating procedures may vary from those described within this manual.

TABLE OF CONTENTS

| | |
|---|------------|
| CHAPTER ONE: PORTLAND CEMENT CONCRETE PAVEMENT | 1-1 |
| DESCRIPTION | 1-1 |
| TYPES OF CONCRETE PAVEMENT | 1-1 |
| <i>Plain Jointed Concrete Pavement</i> | 1-1 |
| <i>Reinforced Jointed Concrete Pavement</i> | 1-2 |
| <i>Continuously Reinforced Concrete Pavement</i> | 1-2 |
| <i>Reinforced Concrete Bridge Approach Pavement</i> | 1-2 |
| CHAPTER TWO: PREPARATION OF THE GRADE | 2-1 |
| GRADE PREPARATION | 2-1 |
| SUBGRADE | 2-1 |
| SUBBASE..... | 2-2 |
| CHAPTER THREE: CONCRETE JOB CONTROL | 3-1 |
| MATERIALS | 3-1 |
| <i>Aggregates</i> | 3-2 |
| <i>Portland Cement</i> | 3-2 |
| <i>Supplementary Cementitious Material, SCM</i> | 3-3 |
| <i>Water</i> | 3-3 |
| CONCRETE MIX CRITERIA | 3-4 |
| CMD PROCESS..... | 3-4 |
| TESTING EQUIPMENT CALIBRATION | 3-5 |
| REFERENCED DOCUMENTS | 3-6 |
| SAFETY | 3-6 |
| SAMPLING CONCRETE..... | 3-6 |
| <i>Sampling from Concrete Trucks</i> | 3-7 |
| <i>Sampling from Grade</i> | 3-7 |
| <i>Sampling from Central Mixed Plants</i> | 3-7 |
| TESTING CONCRETE..... | 3-8 |
| <i>Pressure Method for Air Content</i> | 3-8 |
| <i>Unit Weight and Relative Yield</i> | 3-9 |
| <i>Slump</i> | 3-9 |

| | |
|--|------------|
| <i>Making and Curing Test Specimen</i> | 3-9 |
| <i>Flexural Strength</i> | 3-9 |
| <i>Water/Cementitious Ratio</i> | 3-10 |
| CURING CONCRETE | 3-12 |
| FAILED MATERIALS..... | 3-13 |
| CHAPTER FOUR: EQUIPMENT | 4-1 |
| CONCRETE PLANTS..... | 4-1 |
| <i>Central Mix Plant</i> | 4-1 |
| <i>Ready-Mix Plant</i> | 4-2 |
| DELIVERY EQUIPMENT | 4-2 |
| PAVING EQUIPMENT | 4-3 |
| <i>Finishing Machine</i> | 4-3 |
| <i>Spreader</i> | 4-3 |
| <i>Slip-Form Pavers</i> | 4-3 |
| <i>Hand Placement Finishing Equipment</i> | 4-4 |
| <i>Tining Equipment</i> | 4-4 |
| <i>Vibrators</i> | 4-4 |
| HAND EQUIPMENT..... | 4-5 |
| <i>10 Foot Straightedge</i> | 4-5 |
| <i>Tining</i> | 4-5 |
| <i>Handheld Vibrators</i> | 4-5 |
| <i>Saws</i> | 4-5 |
| <i>Forms</i> | 4-6 |
| CHAPTER FIVE: SETTING FORMS..... | 5-1 |
| FORM FITNESS..... | 5-1 |
| SUBBASE SUPPORT | 5-2 |
| FORM SETTING | 5-2 |
| GRADE AND ALIGNMENT..... | 5-2 |
| CHAPTER SIX: THE PAVING OPERATION | 6-1 |
| CONDITION OF SUBBASE | 6-1 |
| DOWEL BARS AND ASSEMBLIES..... | 6-1 |
| MIXING CONCRETE | 6-2 |
| WEATHER RESTRICTIONS..... | 6-3 |
| PLACING CONCRETE | 6-4 |
| PLACING REINFORCING STEEL | 6-5 |
| STRIKE-OFF, CONSOLIDATION, AND FINISHING..... | 6-5 |
| <i>Floating</i> | 6-6 |
| <i>Checking Finish and Surface Corrections</i> | 6-7 |
| <i>Tining</i> | 6-7 |
| <i>Edging</i> | 6-8 |
| EDGE SLUMP | 6-8 |

| | |
|---|------------|
| PAVEMENT DATES AND STATIONS | 6-8 |
| CURING | 6-9 |
| PROTECTION FROM RAIN | 6-10 |
| REMOVAL OF FORMS..... | 6-10 |
| CHAPTER SEVEN: PAVEMENT JOINTS | 7-1 |
| TYPES OF JOINTS | 7-1 |
| <i>Construction Joints</i> | 7-2 |
| <i>D-1 Contraction Joints</i> | 7-2 |
| <i>Longitudinal Joints</i> | 7-4 |
| <i>Transverse Construction Joints</i> | 7-4 |
| <i>Terminal Joints</i> | 7-5 |
| <i>Expansion Joints</i> | 7-6 |
| <i>Retro-fitted Tie Bars</i> | 7-6 |
| CHAPTER EIGHT: MISCELLANEOUS PAVEMENT DETAILS AND REQUIREMENTS | 8-1 |
| EAR CONSTRUCTION..... | 8-1 |
| PAVEMENT SMOOTHNESS | 8-1 |
| PROTECTION OF PAVEMENT | 8-2 |
| OPENING PAVEMENT TO TRAFFIC..... | 8-2 |
| <i>Construction Vehicles, Equipment, and traffic</i> | 8-2 |
| PAVEMENT THICKNESS..... | 8-3 |
| <i>Coring</i> | 8-3 |
| <i>Core Measurements</i> | 8-3 |
| DEFICIENT PAVEMENT THICKNESS | 8-3 |
| METHOD OF MEASUREMENT AND BASIS OF PAYMENT | 8-4 |
| CHAPTER NINE: CONCRETE PAVEMENT PATCHING | 9-1 |
| MATERIALS | 9-1 |
| CONCRETE MIX DESIGN | 9-1 |
| CONCRETE MIX CRITERIA | 9-1 |
| TRIAL BATCH DEMONSTRATION OF CMDS..... | 9-2 |
| ACCEPTANCE | 9-2 |
| REMOVAL OF CONCRETE | 9-2 |
| <i>Partial Depth Patches</i> | 9-2 |
| <i>Full Depth Patches</i> | 9-3 |
| PLACEMENT OF PATCHING MATERIALS..... | 9-4 |
| <i>Partial Depth Patches</i> | 9-4 |
| <i>Full Depth patches</i> | 9-4 |
| CURING & OPENING TO TRAFFIC..... | 9-6 |
| METHOD OF MEASUREMENT..... | 9-6 |
| BASIS OF PAYMENT | 9-6 |

| | |
|---|-------------|
| CHAPTER TEN: QC/QA PCCP AND PCCP | 10-1 |
| SUBLOTS AND LOTS | 10-1 |
| RANDOM SAMPLING | 10-2 |
| <i>Sampling Procedure</i> | 10-2 |
| <i>Random Numbers</i> | 10-2 |
| <i>Sample Location – Plastic Concrete</i> | 10-3 |
| <i>Sample Location – Cores</i> | 10-4 |
| TRIAL BATCH DEMONSTRATION | 10-5 |
| QUALITY ASSURANCE TESTING | 10-6 |
| <i>Smoothness</i> | 10-6 |
| <i>Thickness</i> | 10-6 |
| <i>Unit Weight</i> | 10-7 |
| <i>Water/Cementitious Ratio</i> | 10-7 |
| <i>Flexural Strength</i> | 10-7 |
| <i>Air Content</i> | 10-7 |
| <i>Contractor Appeal</i> | 10-8 |
| PAY FACTORS | 10-8 |
| <i>Modulus of rupture</i> | 10-8 |
| <i>Air Content</i> | 10-8 |
| <i>Thickness</i> | 10-8 |
| <i>Smoothness</i> | 10-8 |
| QUALITY ASSURANCE ADJUSTMENT | 10-9 |
| <i>Flexural Strength, Air Content, Air Content Range – by lot</i> | 10-9 |
| <i>Thickness – by subplot</i> | 10-9 |
| <i>Smoothness – by section</i> | 10-9 |
| <i>Total Quality Assurance Adjustment</i> | 10-9 |
| FAILED MATERIAL | 10-11 |
| PCCP ACCEPTANCE | 10-11 |

CHAPTER ONE: *PORTLAND CEMENT CONCRETE PAVEMENT*

Pavement is the portion of the road with which vehicles come directly in contact. A rough or pot-holed pavement is hard on vehicles and uncomfortable to motorists. For these and other reasons, a structurally sound, smooth riding, long-lasting pavement is important.

Quality pavement requires materials and construction practices in accordance with the design and specifications for the pavement. Those responsible for assuring this quality are required to know how the pavement is to be built, the Design and Specification requirements, and how to check for compliance with the Design and Specifications.

There are several types of concrete pavements and various requirements for different possible contraction joints. This chapter discusses the different types of concrete pavements and where to find their requirements in the Contract Documents.

DESCRIPTION

PCCP is composed of Portland cement concrete, with reinforcing steel and/or various joint material as specified. Concrete pavement is placed at the thickness specified in the Plans and is constructed on the subbase required by the Contract Documents. The pavement is placed in reasonably close conformance to the lines, grades, and typical cross sections in the Plans.

Concrete consists of Portland cement and water with a mixture of fine and coarse aggregate. Supplementary materials may also be added to the mix: cementitious materials such as fly ash may be added to the mix as a partial substitute for cement, while other materials can assist with water use or air entrainment. Concrete cures via the chemical reaction between cement and water, a curing process which results in a loss of plasticity, causing the concrete to shrink and crack. To control cracking, transverse joints and longitudinal joints are constructed within the pavement. All jointed pavements require transverse joints, or *contraction joints*, to control transverse cracking. Pavements wider than 16 ft require longitudinal joints to control longitudinal cracking.

TYPES OF CONCRETE PAVEMENT

PLAIN JOINTED CONCRETE PAVEMENT

Plain jointed concrete pavement has no longitudinal reinforcing steel but is constructed with transverse joints – joints from one side of the pavement to the other. The types of joints used are shown in Figure 1-1. Plain jointed concrete pavement accounts for nearly all concrete pavement now constructed by INDOT.

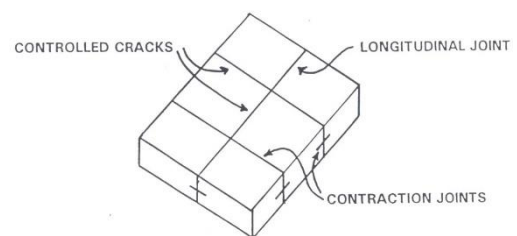

Figure 1-1 Plain Jointed Concrete Pavement

REINFORCED JOINTED CONCRETE PAVEMENT

Reinforced jointed concrete pavement is reinforced with steel mesh and is built with transverse joint spacing of 40 ft. Historically, this type of pavement was the predominant concrete pavement built by INDOT.

CONTINUOUSLY REINFORCED CONCRETE PAVEMENT

Continuously reinforced concrete pavement, or CRC, is reinforced with a large amount of longitudinal steel (No. 5 bars, 6 in on center), and only includes longitudinal joints as required – there are no transverse joints in CRC pavement. CRC pavements have been reintroduced in the past few years as a viable concrete pavement system. Although patching existing CRC pavements presents some challenges compared to patching other types of concrete pavements.

REINFORCED CONCRETE BRIDGE APPROACH PAVEMENT

Reinforced concrete bridge approaches are built at the ends of a bridge and require a minimum length of 20 ft 6 in. They are generally reinforced with two mats of steel and are built to thickness as specified in the Plans. The purpose of a bridge approach is to eliminate settlement of the pavement at the bridge ends. As the bridge end bents are usually on piles, the bridge does not settle, but the end bent backfill usually experiences some settlement. The reinforced concrete bridge approach pavement is usually supported by a pavement ledge on the bridge end and a terminal joint on the end adjacent to the concrete pavement. Additional information regarding reinforced concrete bridge approaches can be found in the **609-RCBA** series of INDOT Standard Drawings.

CHAPTER TWO: *PREPARATION OF THE GRADE*

A concrete pavement is only as good as the grade on which it is placed. This chapter discusses the importance of subgrade preparation, the various types of subbases which may be used under the pavement, maintaining the constructed grade until paving begins, and the final trimming of the subgrade and subbase.

GRADE PREPARATION

The preparation of the subgrade and base course is a very important step, as these materials have a considerable impact on the ride quality of the concrete pavement. Concrete bases and pavement are constructed on *a subbase* which is placed on a prepared subgrade.

SUBGRADE

Prior to constructing the subbase, the subgrade is to be constructed so that the material has a uniform density throughout. Any soft, yielding, or other unsuitable material is required to be removed and replaced if corrective measures are not effective. Proofrolling is done just prior to placing the subbase as per Standard Specifications (SS) **203.26**.

Proofrolling for original ground or embankment construction shall be performed using a dump truck weighing at least 15 t. Proofrolling for subgrade preparation shall be performed using a dump truck weighing at least 33 t. A proofrolled surfaces shall be covered completely in a single pass. Operating speed of the proofrolling truck shall not exceed 2 mph. Deflections or rutting exceeding ½ in shall require remediation of the surface as directed, while deflections or rutting exceeding 3 in shall require corrective remediation measures and the Department's Geotechnical Engineering Division will be contacted. Additional proofrolling shall be performed after remediation measures are taken on embankment or subgrade prior to the placement of additional material. There shall be one or two complete coverages as directed. Roller marks, irregularities, or failures shall be corrected.

Compaction uniformity, correction of unstable areas, and proofrolling of the subgrade should receive special attention at the form lines, when forms are used for paving, or at the track lines, when the slip-form method is used. Settlement of the forms or tracks of the slip-form paver will result in poor-riding pavement. No equipment or traffic is allowed on the finished subgrade, as distortion of the subgrade may occur if weak soil conditions exist, or the subgrade is overly wet.

During subgrade preparation, adequate drainage shall be continuously maintained to prevent standing water on the subgrade. Subbase cannot be placed if the subgrade is frozen or muddy.

The subgrade is required to be finished to within ½ in from the subgrade elevation shown on the Plans. This is important, as a deduction will be made for thin pavement deficiencies greater than one tenth of an in. The subgrade may be trimmed with a conventional grader, but in form paving, these tolerances are usually accomplished with a machine called a sub-grader which rides on the forms (Figure 2-1), and in slip form paving, an auto-grade machine with an automatic grade control sets the grade from a string line.



Figure 2-1 Form Paving Spreader

SUBBASE

Subbase is a foundation course that is placed and compacted on a prepared subgrade. **SS 302** lists the materials and construction requirements for a subbase. Preparation and placement of subbase is required to be in accordance with the requirements of **SS 302**.

INDOT uses two types of subbases in concrete pavements. The most commonly used is Subbase for PCCP, with the other being Dense Graded Subbase.

- Subbase for PCCP consists of a 3 in aggregate drainage layer placed over a 6 in aggregate separation layer. In accordance with **SS 904.03**, the drainage layer consists of No. 8 coarse aggregate and the separation layer consists of No. 53 coarse aggregate.
- Dense Graded Subbase consists of a 6 in layer of No. 53 coarse aggregate in accordance with **SS 904.03**.

Compaction of the separation layer and dense graded aggregate shall be compacted to achieve the maximum allowable deflection as determined with the Light Weight Deflectometer, LWD, testing in accordance with **ITM 508**. Compaction shall not occur if the moisture content of the aggregate is greater than 6.0%. The maximum allowable deflection will be determined from a test section or will be specified. Test section shall be constructed in accordance with **ITM 514** for other materials not included in Table 1 to determine the maximum allowable deflection. The optimum moisture content will be determined in accordance with **SS 203.24(a)**.

Compaction of the drainage layer requires two passes with a vibratory roller before trimming and one pass with the same roller in static mode after trimming.

After the final trimming and compacting of Subbase for PCCP, depth determinations are required for each layer. The Technician should take measurements at a minimum frequency of one depth determination per traffic lane for each 500 linear ft, for each layer of subbase being measured. The technician needs to keep a permanent record of all depth checks, including the date, location, and thickness. This record needs to be submitted to the Project

Engineer/Manager/Supervisor, or PEMS, to verify the quantity of material placed. If deficiencies are found, appropriate measures are required to be taken. If more material is required, the additional material is mixed with the layer and the layer is re-compacted. Additional depth determinations are then obtained in the same manner and frequency as before.

The width of the subbase must also be checked and recorded by the Technician. The frequency of these width checks should match the depth check frequency. These checks are required to calculate and verify the quantity of material placed in cubic yards.

Allowable Average Deflection and Maximum Deflection for Chemically Modified Soils and Aggregate over Chemically Modified Soils.

| Material Type | Allowable Average Deflection (mm) | Maximum Deflection at a Single Test Location (mm) |
|-------------------------------------|-----------------------------------|---|
| Lime Modified Soil | ≤ 0.30 | 0.35 |
| Cement Modified Soil | ≤ 0.27 | 0.31 |
| Aggregate over Lime Modified Soil | ≤ 0.30 | 0.35 |
| Aggregate over Cement Modified Soil | ≤ 0.27 | 0.31 |

Table 2-1 Allowable Deflection Table, SS 203.24

CHAPTER THREE: *CONCRETE JOB CONTROL*

Concrete used in pavements on INDOT contracts must meet the requirements of **SS 501** or **502**. Concrete pavements used as a base must meet the requirements of **SS 305**. Patching concrete must meet the requirements of **SS 506**. To verify the concrete meets applicable specification requirements, the Technician must perform job control sampling and testing of both freshly mixed and hardened concrete.

Concrete pavements meeting the requirements of **SS 501** are referred to as Quality Control/Quality Assurance Portland Cement Concrete Pavement, or QC/QA PCCP. Concrete pavements meeting the requirements of **SS 502** are simply referred to as Portland Cement Concrete Pavement, or PCCP.

Prior to concrete production, the Technician should participate in the trial batch demonstration to verify that the concrete plant is utilizing Certified Aggregate Producer Program (CAPP) approved aggregates as well as approved cement, supplementary cementitious materials (SCMs) and admixtures. The Technician also determines if all job control testing equipment has been calibrated and is in good working order. The sampling and testing methods required by the Contract and the frequency of each test in accordance with the Manual of Frequency for Sampling and Testing should be reviewed. The Manual for Frequency of Sampling and Testing and approved lists for the various materials used in concrete production can be found on the Division of Materials and Tests website.

MATERIALS

Paving concrete is composed of the following materials (Figure 3-1):

- Fine aggregate
- Coarse aggregate
- Portland cement
- Water

Additional materials that may be found in paving concrete include:

- Fly Ash, Silica Fume, or Slag Cement
- Water-reducing admixture
- Air-entraining admixture

Proportions vary due to different types of concrete, based on their purpose and Mix Design. Prior to production, the Contractor is responsible to complete the concrete mix design (CMD) process. **SS 501.04** outlines the requirements of the process, and additional information is included later in this chapter.

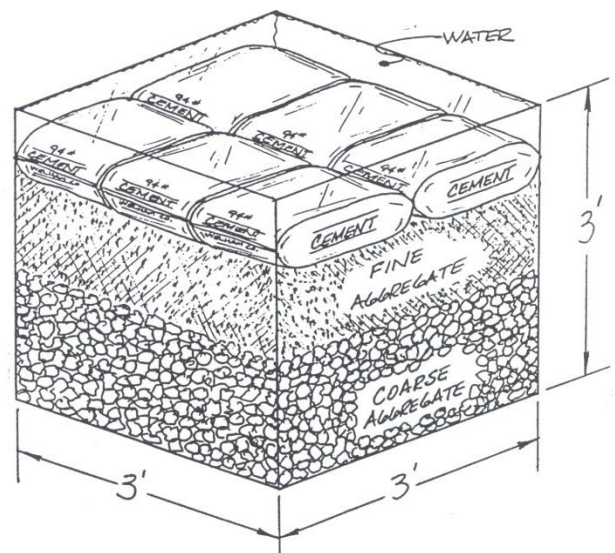

Figure 3-1 Concrete Materials

AGGREGATES

As mentioned previously, concrete mixes include two aggregate types. Fine aggregates are sands, usually meeting No. 23 aggregate gradation requirements. Concrete used in QC/QA PCCP may use an alternate gradation if identified in the Contractor's Quality Control Plan, or *QCP*. Coarse aggregates are larger particles, usually meeting the gradation requirements for No. 8 coarse aggregate. Concrete used in QC/QA PCCP may also use an alternate coarse aggregate gradation if identified in the *QCP*. **SS 904.02(d)** requires that fine aggregate included in concrete used for base, pavement, and patching to be natural sands. **SS 904.03** includes the classification requirements for coarse aggregate materials. The proportion of the aggregates is important to the integrity of the concrete and ultimately affects the strength and the durability of the pavement. **ITM 226** is used to evaluate coarse aggregates and coarse aggregate blends for use in concrete mixtures. The Tarantula Curve (Figure 3-2) is a tool used to evaluate aggregate proportioning for QC/QA concrete mixtures.

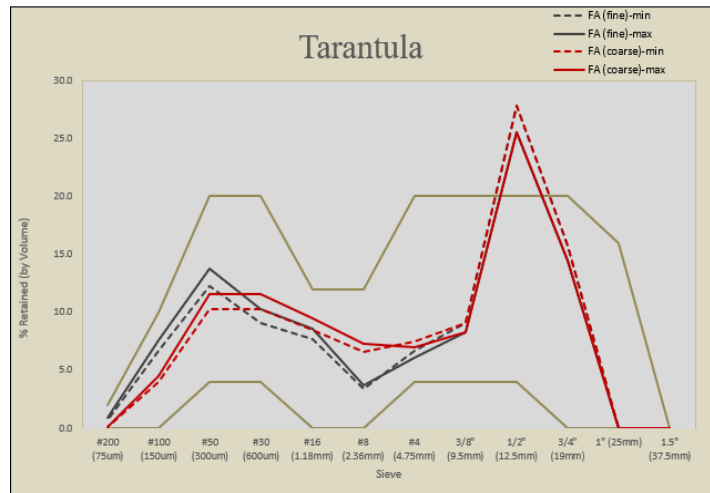

Figure 3-2 The Tarantula Curve

PORTLAND CEMENT

There are many different types of cement available for concrete. Only the following five are discussed:

- Type I – Portland cement (being phased out)
- Type I-A – Air-entrained Portland cement (being phased out)
- Type IL -Portland-Limestone cement (Used most often)
- Type IP-A – Air-entrained Portland-pozzolan cement
- Type III – High-early-strength cement
- Type III-A – Air-entrained high early strength cement

Under normal conditions, Portland cement (Type IL) is used in paving concrete. Air-entrained Portland cement (Type IL-A) is cement that has been entrained with air during the manufacturing process and requires less air-entraining agent to be added to obtain the required air content. Air-entrained Portland-pozzolan cement (Type IP-A) is like Type IL-A except that it additionally contains a pozzolan, such as fly ash, to reduce the cost. When Type IP-A cement is used, consult the Supplementary Cementitious Material specifications regarding allowable ambient temperature requirements. High-early-strength Portland cement (Type III) is formulated to obtain strength more quickly than Type IL. Type III-A contains additional air that has been entrained during the manufacturing process.

Unless otherwise specified, each cubic yard of paving concrete contains 564 lbs, or six bags, of cement. To verify that the concrete used meets this requirement, the Technician will perform

a unit weight/relative yield test at the paving site as the first load begins discharging. This test determines the actual amount of cement in each cubic yard of concrete. If the test results show the cement content is too high or too low, the cement-to-aggregate ratio must be remedied. To do so, the aggregate batch weights will be increased or decreased accordingly, to bring the cement content back to the expected level. Additional information regarding unit weight/relative yield testing follows later in this chapter.

SUPPLEMENTARY CEMENTITIOUS MATERIAL, SCM

Fly ash is the most common Supplementary Cementitious Material, or SCM. Fly ash is a powdery by-product of coal-fired electrical generating plants and has similar structural properties to cement. Using SCMs reduces the cost of concrete by reducing the amount of cement required to attaining the required level of binding, but also generally extends the time needed to achieve the proper compressive strength to allow for opening pavement to traffic. When an SCM is included in a mix, the Technician is required to cast concrete beams (Figure 3-3) in conjunction with each pour. The flexural strength of these beams is the only factor used to determine the opening of the pavement to traffic. Additional information related to flexural strength testing can be found later in this chapter.



Figure 3-3 Concrete Beam Used for Flexural Testing

The two types of fly ash used in PCCP are Class C and Class F. Class C fly ash has better structural qualities than Class F and is therefore preferred. **SS 501.15** provides information on cold weather limitations of the PCCP. Per **SS 502.04**, SCM may only be incorporated in the concrete mix when the ambient temperature exceeds 50° F for the entire placement period.

The minimum cement/SCM ratios for QC/QA PCCP are included in **SS 501.05**. **SS 502.04** includes information related to the maximum cement reduction for fly ash replacement and fly ash/Portland cement substitution ratios for regular paving concrete and high-early-strength concrete mixes.

WATER

When water is added to cement, the curing process begins. In a central mix plant this occurs in the mixing drum, while in a transit mix this process occurs in the truck mixer. Only clean, potable water shall be used – contaminated water may contain material detrimental to the concrete composition. After water is added to the mix, the clock starts; the time the water is added to the concrete at the concrete plant is indicated on the ticket. From then:

- For PCC base QC/QA PCCP and PCCP concretes, the concrete must be placed within 90 minutes if hauled in mixer trucks or trucks equipped with agitators; if the hauling vehicle has no agitator, the time allowance is reduced to 30 minutes when temperatures are over 90° F, or 45 minutes for cooler temperatures.

- For patching mixtures, the concrete must be placed within 30 minutes of the time that water is added if hauled in a truck with no agitators. If the truck has agitators or if a truck mixer is used, the concrete must be placed within 90 minutes of the time that water was added or within 30 minutes of introduction of calcium chloride solution, whichever is less.

The amount of water added at the plant will vary from day to day depending on the moisture contents of the fine and coarse aggregate used. An overnight rain can cause wetter stockpiled materials, and therefore less water will need to be added to achieve the same moisture content. Conversely, material exposed to hot, dry conditions for several days will require more water to be added. The mixture is required to contain no more water than is necessary to produce a concrete that is workable, plastic, and meets Slump requirements. However, the water-cementitious ratio must always meet the Specification limit.

CONCRETE MIX CRITERIA

The CMD shall contain at least one, but not more than two SCM's, and produce workable concrete mixtures having the following properties, per **SS 501.05**:

| | |
|---|------------------------|
| Minimum total cementitious content | 450 lb/yd ³ |
| Allowable amount of single SCM | |
| % of total cementitious, by weight..... | 25.0% - 40.0% |
| Allowable amount of two SCM's, | |
| % of total cementitious, by weight..... | 25.0% - 40.0% |
| Minimum Portland cement content..... | 275 lb/yd ³ |
| Allowable amount of silica fume as SCM, | |
| % of total cementitious content | 3.0% - 7.0% |
| Maximum allowable water/cementitious ratio of | |
| concrete mixture with fly ash as SCM..... | 0.440 |
| Maximum allowable water/cementitious ratio | |
| of concrete mixture with slag cement as SCM | 0.450 |
| Target Air Content..... | 7.0% |
| Minimum modulus of rupture | 570 psi at 7 days |

CMD PROCESS

The first step in the CMD process is the preparation of a Concrete Mix Design Submittal, or CMDS, in the Department-requested format by the Contractor, who will submit it to the District Testing Engineer or DTE.

This must be done at least seven calendar days prior to the performance of a trial batch if required by **SS 501.06**. The Technician will participate in the trial batch by performing side-by-side tests with Contractor personnel to verify that the CMDS meets all requirements contained in **SS 501.06**. Upon completion of the trial batch, the Contractor is required to submit documentation related to the second stage of the CMD process—the concrete mix design for production, or CMDP. This submittal is required at least 3 working days prior to the start of paving operation and is made to the DTE. The Technician's test results are required to

accompany the Contractor's CMDP submittal. Upon Department acceptance of the CMDP, the Contractor may begin producing this concrete for the paving operation.

Should the Contractor's CMDS *not* require a trial batch per **SS 501.06**, the DTE will review, process, and accept the mix design as a CMDP. After acceptance, the Contractor may alter a CMDP in one of the following ways:

- Change in materials per **SS 501.04(a)**
- Adjustment to materials per **SS 501.04(b)**
- Other adjustments per **SS 501.04(c)**

When a *change in materials* is proposed for a concrete mix, a new CMDS reflecting the changes must be submitted by the Contractor to the DTE. When this occurs, the Contractor may perform a trial batch as described above, or request *First Day Verification* – performing trial batch testing on concrete produced for the first day of production, per **SS 501.04(a)**. If First Day Verification is used, the Engineer must coordinate sampling and testing with the Technician and Contractor personnel to evaluate the concrete shortly after production begins. If random sampling indicates that an acceptance test is to be performed during this period, the acceptance testing can be used by the Technician to evaluate the CMDS. If any tests during this period indicate failure to meet specification requirements, the Technician will notify the PEMS as soon as possible so the paving operation can be halted. Any pavement constructed prior to the suspension of paving operations must be handled as failed material. Failed material will be discussed further on in this chapter.

If the previously approved CMDP is adjusted in accordance with **SS 501.04(b)**, the Contractor is required to submit information related to the material adjustment to the DTE for approval. After DTE approval is obtained, a new CMDP is issued, and production can resume. Neither a trial batch nor verification on the first day of production CMDP is required for an adjusted CMDP. Random acceptance sampling and testing performed by the Technician is not affected by the Contractor's use of an adjusted CMDP.

With proper notification to the PEMS, the Contractor may incorporate other material adjustments to a CMDP in accordance with **SS 501.04(c)**. Such adjustments are minor and do not require a new CMDS, nor do they require DTE approval.

It should be noted that the specifications do allow the Contractor to utilize a previously approved CMDP from another contract. However, changing or adjusting the CMDP will require DTE approval in accordance with **SS 501.04(a)** and **501.04(b)**, respectively.

TESTING EQUIPMENT CALIBRATION

All concrete job-control testing equipment is required to be calibrated at the proper frequency. The calibration process includes sieves, electronic scales, air test equipment, slump equipment, thermometers, and equipment for determination of the unit weight of concrete. Flexural strength testing machines and compressive strength testing machines are required to be calibrated annually and after being moved. INDOT compressive strength testing machines are calibrated by companies under contract to INDOT. Compressive strength and flexural strength testing machines used by the Contractor on contracts including QC/QA PCCP pay items are

required to be calibrated. The calibrations of the equipment at these locations are the responsibility of the Contractor or the Supplier. Calibration documentation should be produced by the Contractor or Supplier for each testing machine and reviewed by District Testing personnel prior to the machine testing INDOT concrete.

The following documents should be reviewed by the Technician for additional information related to testing equipment calibration:

- **AASHTO T 152** - Air Meter and Unit Weight Containers
- **ITM 902** – Sieves
- **ITM 903** – Ovens
- **ITM 910** – Electronic Balances
- **ITM 911** - Slump Cones

REFERENCED DOCUMENTS

ITM and **AASHTO** test methods are used for concrete job control. INDOT Specifications contain several exceptions to the **AASHTO** test methods. If there are INDOT exceptions to **AASHTO**, then INDOT Specifications take precedence over **AASHTO** test methods. The **AASHTO** test methods and **SS 505** should be reviewed for any corresponding exceptions. The Special Provisions of a contract may have additional or different exceptions than those found in **SS 505**.

SAFETY

Prolonged exposure of skin and tissue to concrete may be harmful. Therefore, the Technician should wear plastic or latex gloves while sampling and testing of concrete. Protective eye wear is also recommended because concrete may splatter during testing.

SAMPLING CONCRETE

AASHTO R 60 is the test method required for sampling freshly mixed concrete. An exception to this test method that INDOT allows is that the entire sample may be obtained from one portion of the load. Obtaining a representative sample of the concrete to be tested is important for assuring an accurate determination of the concrete properties. If any sample is improperly taken, then the test results are not acceptable. Representative material is important for samples taken by the Contractor for job control, samples taken by independent testing companies, and samples that are used to appeal INDOT test results. Although **AASHTO R 60** does not define the sampling container, other test methods are very specific on acceptable types of containers. A wheelbarrow meets the requirements of all the **AASHTO** test methods used for acceptance testing of concrete by INDOT and therefore is generally used as the sampling and mixing container.

INDOT test samples are obtained at the point of placement whenever possible. QC/QA PCCP and PCCP samples are taken on the grade after the material has been placed by a material transfer machine, but before the concrete paver has distributed the mixture. When samples are taken near operating equipment, communication between all personnel associated with obtaining the sample and equipment operators must be clear at all times.

INDOT allows two types of sampling of freshly mixed, plastic concrete:

1. A composite sample consisting of two or more increments taken from the batch and mixed together in the sampling receptacle.
2. One large increment taken from one portion of the load.

The type of sample required is determined by the sampling test method. Regardless of how the sample is obtained, it should take no more than 15 minutes to gather a sufficient quantity for testing. Also, no material is to be obtained for testing before ~10% of the load has been discharged or after ~90% of the load has been discharged.

SAMPLING FROM CONCRETE TRUCKS

When sampling from a revolving drum truck mixer (transit-mix truck) or an agitator truck, the sample may be obtained by directing the chute to a wheelbarrow or receptacle on the ground near the testing site (Figure 3-4). The sample should be obtained from resting concrete, not from the chute of the truck or from the discharge stream while filling the receptacle.



Figure 3-4 Truck sampling1

SAMPLING FROM GRADE

When sampled from the grade, the sample must be taken before the concrete comes in contact with machinery (Figure 3-5). When obtained from a pile on the grade or ground, samples are to be taken from five different portions of the pile and should not be contaminated with the base material.



Figure 3-5 Sampling from Grade

After obtaining the sample, all portions are mixed together with a shovel the minimum amount necessary to obtain uniformity, to ensure testing integrity.

SAMPLING FROM CENTRAL MIXED PLANTS

When concrete is sampled for testing at a central mix plant, such as would be required for a trial batch, the plant will load a sufficient quantity directly into the bucket of a loader (Figure 3-6). The loader bucket is cleaned ahead of time to minimize contamination of the sample.



Figure 3-6 Loading a bucket

The loader will then transport the material to the testing location where the concrete is sampled (Figure 3-7). After sampling, all portions are thoroughly mixed together with a shovel the amount necessary to obtain proper uniformity (Figure 3-8), and testing can proceed.



Figure 3-7 Sampling from a Loader



Figure 3-8 Mixing a Sample

TESTING CONCRETE

To perform the required test and have them used as acceptance criteria for an INDOT contract, the Federal Highway Administration (FHWA) requires the Technician to be qualified in the Test Method being performed. In order to attain this designation, the Technician must exhibit competency in written form and through accurately performing the testing procedures while under the supervision of a Testing Department designee. The PEMS should work with the Technician to arrange a Testing representative to qualify the Technician for field tests. This should be done prior to any acceptance testing on the contract.

Concrete tests performed by the Technician for QC/QA PCCP or PCCP are typically taken for acceptance or to verify that the newly constructed pavement has achieved sufficient strength to withstand the traffic load. Acceptance testing verifies the representative sample of concrete meets the requirements for any properties tested, and results must be recorded in the Sampling and Testing system via Field Assistant.

PRESSURE METHOD FOR AIR CONTENT

AASHTO T 152 is the required test method for determining the air content of freshly mixed concrete by the pressure method. An aggregate correction factor is required and is dependent on the source of the fine aggregate, the source and the ledges of the coarse aggregate, and the percentages of each used in the mix. The aggregate correction factor should be checked each time one of these factors changes and can be found on the CMDS or CMDP. **T 152** requires a 16-in tamping rod in addition to the Air Meter container shown in Figure 3-9.



Figure 3-9 Type B Air Meter

The initial pressure line of the air meter is meter specific and is checked and recorded with the annual calibration. Air meters are required to be verified in the field every three months. Part of this verification is to check the initial pressure line. The calibration forms and field verification forms should accompany each air meter. Air content test results are entered into the Sampling and Testing system via Field Assistant.



Figure 3-10 Slump Cone

UNIT WEIGHT AND RELATIVE YIELD

AASHTO T 121 is the prescribed test method for determining the unit weight and relative yield of freshly mixed concrete. For QC/QA PCCP, the unit weight requirements are included in **SS 501.27(a)**. The relative yield requirements for PCCP are included in **SS 502.04** for both regular and high-early-strength mixes. A 24-in tamping rod is required for this test. Unit weight & relative yield test results are entered into the Sampling and Testing system via Field Assistant.

To simplify testing procedure, unit weight and air content tests may be run at the same time with the same sampled concrete. In this case, the Technician may use a 24-in tamping rod to meet the requirements for both tests.

SLUMP

AASHTO T 119 is required for determining the slump of the concrete, and the slump cone (Figure 3-10) is its primary required equipment.

For QC/QA PCCP, slump measurements are not used for acceptance but may be performed up to two times per truckload to verify concrete has been mixed consistently. For PCCP, the Technician is required to perform slump tests for acceptance per **SS 502.05**.

T 119 test results are entered into the Sampling and Testing system via Field Assistant.

MAKING AND CURING TEST SPECIMEN

AASHTO T 23 is the test method used for making and curing concrete test specimens in the field. This procedure includes the methods used for flexural strength beams. As it is often important to open newly constructed QC/QA PCCP or PCCP to traffic as soon as possible, the Engineer and Technician should communicate with the Contractor to ensure a sufficient number of beams are cast for testing.

FLEXURAL STRENGTH

AASHTO T 97 is the test method used to determine the flexural strength of concrete beams. This test consists of breaking test beams on a self-recording beam breaker (Figure 3-11) and calculating the flexural strength results. For QC/QA PCCP, flexural strength tests are required for acceptance and opening the pavement to traffic. For PCCP, flexural strength tests are only required for determining whether the pavement is ready for traffic. **SS 501.05, 501.23, and 502.18** include the flexural strength requirements. Review *The Manual for Frequency of Sampling and Testing* for the required sampling and testing frequency. Table 3-1 (next page) Flexural Strength Factors is used in conjunction with measurements and the **T 97** test results to determine flexural strength and is a built-in function



Figure 3-11 Flexural Strength

of Field Assistant. When the beam break test results are entered into the Sampling and Testing system via Field Assistant, ensure you have the correct test method selected as it will determine the number of beams to break, the automatic calculation results, and that your test results will be counted towards your frequency requirements within the system.

FACTORS FOR CALCULATING MODULUS OF RUPTURE (M_{OR})

| | | BEAM WIDTH IN INCHES (b) | | | | | | | | |
|--------------------------|---------|--------------------------|--------|-------|--------|-------|--------|-------|--------|-------|
| | | 5 3/4 | 5.8125 | 5 7/8 | 5.9375 | 6 | 6 1/16 | 6 1/8 | 6 3/16 | 6 1/4 |
| BEAM DEPTH IN INCHES (d) | 5 3/4 | 1.136 | 1.124 | 1.112 | 1.100 | 1.089 | 1.078 | 1.067 | 1.056 | 1.045 |
| | 5 13/16 | 1.112 | 1.100 | 1.088 | 1.077 | 1.066 | 1.055 | 1.044 | 1.033 | 1.023 |
| | 5 7/8 | 1.088 | 1.077 | 1.065 | 1.054 | 1.043 | 1.032 | 1.022 | 1.011 | 1.001 |
| | 5 15/16 | 1.066 | 1.054 | 1.043 | 1.032 | 1.021 | 1.011 | 1.000 | 0.990 | 0.980 |
| | 6 | 1.043 | 1.032 | 1.021 | 1.011 | 1.000 | 0.990 | 0.980 | 0.970 | 0.960 |
| | 6 1/16 | 1.022 | 1.011 | 1.000 | 0.990 | 0.979 | 0.969 | 0.959 | 0.950 | 0.940 |
| | 6 1/8 | 1.001 | 0.991 | 0.980 | 0.970 | 0.960 | 0.950 | 0.940 | 0.931 | 0.921 |
| | 6 3/16 | 0.981 | 0.971 | 0.960 | 0.950 | 0.940 | 0.931 | 0.921 | 0.912 | 0.903 |
| | 6 1/4 | 0.962 | 0.951 | 0.941 | 0.931 | 0.922 | 0.912 | 0.903 | 0.894 | 0.885 |

$$F = 216 / (b \cdot d^2)$$

Table 3-1, Flexural Strength Factors

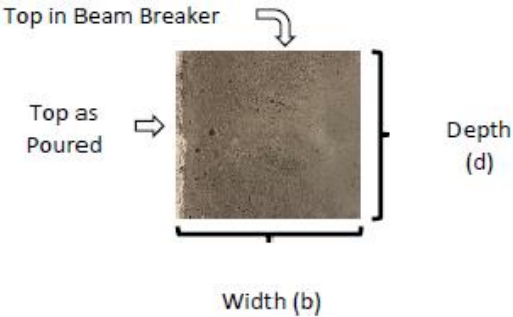

WATER/CEMENTITIOUS RATIO

ITM 403 is used for determining the water/cementitious ratio of concrete. Representative sampling of the fine aggregate and the coarse aggregate for moisture content is critical to determine this value on the day of the concrete pour. If the moisture content of the aggregates change, the batch weights are to be changed accordingly to maintain the proper proportions of materials to produce a cubic yard of concrete. The form required to calculate the water/cementitious ratio is included in **ITM 403**. The water/cementitious ratio test result is input into the Sampling and Testing portion of the Materials Management module of SiteManager.

The water/cementitious ratio is determined in accordance with The Manual for Frequency of Sampling and Testing, but at least once per contract. This calculation is performed to determine the amount of free water in the concrete batch. The free water is the total of all water added at the jobsite plus the water on the aggregates in excess of the amount of water required to satisfy the absorption of the fine and the coarse aggregates.

Free water is expressed in pounds of water per pound of cement and the ratio of the two is called the water to cementitious ratio. If supplementary cementitious material such as fly ash, Silica Fume, or Slag Cement are included in the concrete mixture, then the weight of supplementary cementitious material is added to the cement weight.

EXAMPLE 1

Calculate the weight of the dried sample using the following *Table 3-2, Dry Sample Weight*:

Weight of Dried Sample & Pan – Weight of the Pan

Course Agg $18.4 - 2.5 = 15.9$

Fine Agg $16.3 - 2.5 = 13.8$

Table 3-2, Dry Sample Weight

| Line | Procedure | Method | Coarse Agg. | Fine Agg. |
|------|--|-----------------------|-------------|-----------|
| A | Weight of wet sample & pan, 0.01 lbs. | Weigh | 19.01 | 17.2 |
| B | Weight of dried sample & pan, 0.01 lbs. | Weigh | 18.4 | 16.3 |
| C | Weight of water in sample, 0.01 lbs. | A-B | 0.61 | 0.9 |
| D | Weight of pan, 0.01 lbs. | Weigh | 2.5 | 2.5 |
| E | Weight of dried sample, 0.01 lbs. | B-D | | |
| F | Percent Moisture, 0.01% | $(C / E) \times 100$ | | |
| G | Percent Absorption, 0.01% | CMD | | |
| H | Weight of wet aggregate in batch, 1 lb. | Batch Ticket | | |
| I | Weight of dry aggregate in batch, 1 lb. | $H / [1.0 + (F/100)]$ | | |
| J | Weight of water in aggregate in batch, 1 lb. | H-I | | |
| K | Weight of water absorbed in batch, 1 lb. | $I \times (G/100)$ | | |
| L | Total weight of water in aggregates, 1 lb. | Sum of line J | | |
| M | Total weight of water absorbed, 1 lb. | Sum of line K | | |
| N | Total of all water added to batch, 1 lb. | Batch Ticket x 8.33 | | |
| O | Total free water in batch, 1 lb. | $N + L - M$ | | |
| P | Weight of Portland cement in batch, 1 lb. | Batch Ticket | | |
| Q | Total weight of pozzolans in batch, 1 lb. | Batch Ticket | | |
| R | Total wt. of cementitious mat. in batch, 1 lb. | $P + Q$ | | |
| S | Water / cementitious ratio, 0.001 | O / R | | |

EXAMPLE 2

Calculate the percent moisture using the following *Table 3-3, Percent Moisture*:

Weight of Water in Sample / Weight of Dried Sample x 100

Course Agg $0.61 / 15.9 \times 100 = 3.84\%$

Fine Agg $0.90 / 13.8 \times 100 = 6.52\%$

Table 3-3, Percent Moisture

| Line | Procedure | Method | Coarse Agg. | Fine Agg. |
|------|--|-----------------------|-------------|-----------|
| A | Weight of wet sample & pan, 0.01 lbs. | Weigh | 19.01 | 17.2 |
| B | Weight of dried sample & pan, 0.01 lbs. | Weigh | 18.4 | 16.3 |
| C | Weight of water in sample, 0.01 lbs. | A-B | 0.61 | 0.9 |
| D | Weight of pan, 0.01 lbs. | Weigh | 2.5 | 2.5 |
| E | Weight of dried sample, 0.01 lbs. | B-D | 15.9 | 13.8 |
| F | Percent Moisture, 0.01% | (C / E) x 100 | | |
| G | Percent Absorption, 0.01% | CMD | | |
| H | Weight of wet aggregate in batch, 1 lb. | Batch Ticket | | |
| I | Weight of dry aggregate in batch, 1 lb. | $H / [1.0 + (F/100)]$ | | |
| J | Weight of water in aggregate in batch, 1 lb. | H-I | | |
| K | Weight of water absorbed in batch, 1 lb. | $I \times (G/100)$ | | |
| L | Total weight of water in aggregates, 1 lb. | Sum of line J | | |
| M | Total weight of water absorbed, 1 lb. | Sum of line K | | |
| N | Total of all water added to batch, 1 lb. | Batch Ticket x 8.33 | | |
| O | Total free water in batch, 1 lb. | N + L - M | | |
| P | Weight of Portland cement in batch, 1 lb. | Batch Ticket | | |
| Q | Total weight of pozzolans in batch, 1 lb. | Batch Ticket | | |
| R | Total wt. of cementitious mat. in batch, 1 lb. | P + Q | | |
| S | Water / cementitious ratio, 0.001 | O / R | | |

CURING CONCRETE

Using the proper curing method is essential during the early stages after the concrete is placed to allow it to develop strength and durability. Proper curing is intended to allow the moisture in the concrete to evaporate slowly. Satisfactory curing is obtained by keeping the concrete cool and wet during the summer and not allowing it to freeze during the winter. **SS 501.20**, **502.15** and **504.04** cover acceptable methods to protect concrete from freezing and proper curing methods.

FAILED MATERIALS

Pay items associated with QC/QA PCCP and PCCP require job control tests performed at the frequency included in the Manual for Frequency of Sampling and Testing. Test results that are not within the specification requirements require the Technician to inform the PEMS of the deficiency as soon as possible. Depending on the property tested and the magnitude of the test failure, the PEMS may have to suspend the paving operation until the Contractor demonstrates that a mixture complying with the specification requirements can be produced. Changes in additive rates of admixtures, changes in the amount of water added, or changes in the batch weights of the aggregates may be necessary to bring the subsequent tests into compliance.

There is a failed materials process to determine whether the QC/QA PCCP or the PCCP associated with a failed test may remain in place with reduced compensation to the Contractor or if the newly constructed pavement requires removal and replacement. More information regarding the failed materials process is included in *Chapter Ten: QC/QA PCCP and PCCP*.

CHAPTER FOUR: *EQUIPMENT*

The importance of having the proper equipment to do the job correctly and efficiently cannot be overstated, especially for construction of concrete pavements. This chapter discusses concrete equipment that has a profound effect on the quality of the final pavement.

CONCRETE PLANTS

INDOT categorizes concrete plants as central mix plants or ready-mix plants. Central mix plants, sometimes known as portable plants, are usually owned by the Contractor, and constructed on a temporary basis on or adjacent to the project site. A central mix plant is usually used to produce concrete for a specific INDOT contract. When the contract is completed, the plant is disassembled and moved. Ready-mix plants are usually permanent installations owned by an entity other than the Contractor and serve many customers.

Concrete plants are inspected and certified by the District Testing personnel. Ready-mix plants are inspected once a year. Central mix plants are inspected at the beginning of each construction season and whenever they are moved to a new location. During a plant inspection, District Testing personnel verify all scales are balanced and that all conveyors and hoppers are generally clean and free of foreign materials.

A concrete plant includes several components such as bins for the cement, weighing hoppers, scales for fine and coarse aggregates, admixture dispensers, and material conveyors. Most concrete plant operations utilize one of a variety of computer systems. The system calculates and drops or conveys each material into the hopper following the Mix Design.

CENTRAL MIX PLANT

Central mix plants (Figure 4-1) are mobile units located near one or more worksites where large quantities of concrete are to be used. A central mix plant proportions and mixes the concrete at the plant.

For QC/QA PCCP, the Contractor includes the central plant mixing requirements in the Quality Control Plan, or QCP.

For PCCP, the central mix plant mixing is required to be no less than 60 seconds for each batch. When using a transit mixer for additional mixing, the mixing time in the central mix plant may be reduced to approximately 30 seconds.

The freshly mixed concrete is deposited into trucks for delivery. The delivery truck from a central mix plant does not need to provide any further mixing of the concrete unless an optional transit mix truck is used.



Figure 4-1 Central Mix Plant

READY-MIX PLANT

The second type of plant used is the ready-mix plant (Figure 4-2). Ready-mix plants batch the ingredients into a truck-mixer and the revolving drum on the truck mixes the ingredients.



Figure 4-2 Ready Mix Plant

DELIVERY EQUIPMENT

Concrete is typically delivered to the jobsite in transit mixer trucks, agitator trucks, or non-agitator trucks. All delivery trucks are required to comply with **SS 501, 502, and 508**.

Transit mixer trucks are designed to mix concrete at or on the way to the project site. For this reason, transit mixer trucks always have a water tank on board and a measuring device that is capable of controlling the amount of water that is added to the mix.

When transit mixer trucks (Figure 4-3) are used, the following items are required to be checked by the Technician:

- Manufacturer's rating plates are in place and legible
- Revolution counters are operating properly
- Mixing speed is as shown on the manufacturer's rating plate, and number of drum revolutions is following the equipment specifications.
- Trucks are operated at or below their rated capacity
- Discharge of the concrete is completed within 90 minutes of mixing water, cement, and aggregates

Agitator and non-agitator trucks deliver concrete that has already been mixed. These trucks are not capable of mixing additional water, and none may be added. Any water on board is for cleaning purposes only, not for mixing.

When non-agitator trucks are used, the truck beds are required to be smooth, mortar tight metal containers capable of discharging the concrete at a satisfactorily controlled rate without segregation. The concrete is discharged from the bottom of the container. When the discharge is done by tilting, the container is required to be baffled to retard the flow of the mix. Covers are provided for protection of the concrete, when required. The discharge of the concrete is required to be completed within 30 minutes of mixing the water, cement, and aggregates when the concrete temperature is 90° F or higher or 45 minutes when it is cooler.



Figure 4-3 Transit Mixer

Regardless of the type of equipment used to deliver the concrete to the job site, the concrete is required to be uniformly mixed. Slump tests in addition to any required for acceptance may be taken by the Technician to verify uniformity of the mixture in accordance with **SS 501.14** for QC/QA PCCP or **SS 502.10** for PCCP. The uniformity testing will consist of slump tests taken in accordance with **AASHTO T 119**. If the slumps differ by more than 1 in when the average slump is 3 in or less, or by more than 2 in when the average slump is greater than 3 in, paving

operations may be suspended while the mixing process is jointly reviewed, and problems resolved by the Engineer and the Contractor.

PAVING EQUIPMENT

FINISHING MACHINE

The finishing machine (Figure 4-4) is the device that rides on top of the forms and strikes off the concrete to the proper grade. Finishing machines are required to have two or more oscillating type transverse screeds and a transverse smoothing float. The transverse screed and float are suspended and guided by a rigid frame with a maximum effective wheelbase of 14 ft. The float is approximately 2 in less than the nominal width of the pavement, with an adjustable crown section, and has an adjustable forward speed. The oscillating motion of the screeds consolidates the concrete. The finishing machine may also be fitted with concrete vibrators.



Figure 4-4 Finishing Machine

SPREADER

A concrete spreader (Figure 4-5) is a device which rides on the forms in front of the paver and spreads the concrete evenly after the concrete has been discharged onto the grade by the delivery truck. In slip-form paving, the spreader rides on tracks similar to the paver. The use of a spreader is not required but allows paving to proceed faster by reducing the work of the finishing machine.



Figure 4-5 Concrete Spreader

SLIP-FORM PAVERS

The slip-form paver (Figure 4-6) differs from the finishing machine in that the forms are mounted to the machine instead of being stationary. As the slip-form paver passes over the concrete, the concrete is spread, consolidated, and finished. Only a small amount of handwork is required after the concrete is placed. The slip-form paver rides on tracks and is usually controlled by a preset stringline. The paver is equipped with an automated steering and elevation control system. Sensors ride on the stringline and transmit line and grade information to the paver. Grade information is taken from the subbase



Figure 4-6 Slip-Form Paver

or from a ski. The paver must be of sufficient weight and power to place the concrete at an adequate variable forward speed without transverse, longitudinal, or vertical instability. Since the slip-form paver does all the forming of the pavement, the paver should be stopped only when absolutely necessary. When stopped, the paver may leave a slight imperfection in the pavement. All vibrators and tampers should be turned off immediately if the paver is stopped.

Slip-form paver requirements are included in **SS 508.04(a)**.

HAND PLACEMENT FINISHING EQUIPMENT

Hand placement finishing equipment is required to produce a concrete pavement with a uniform surface that is free of voids and meets the specified smoothness. The mechanical tube finisher, vibratory screed finisher, and mechanical bridge deck finisher are three types of hand placement finishing equipment that are used. The requirements for these types of hand placement finishing equipment are included in **SS 508.04(c)3**.

TINING EQUIPMENT

The tining equipment (Figure 4-7) is a device that automatically places grooves in the pavement using a mechanical device with steel tines spaced as specified. The grooves are placed in the pavement to provide additional skid resistance and eliminate hydroplaning. The Contractor shall oversee the tining operation to ensure the forming of straight, uniform grooves in the textured, plastic PCCP surface without tearing the concrete surface.



Figure 4-7 Tining Equipment

VIBRATORS

Vibrators come in two standard forms, and consolidate, or fill in, larger air voids in the mix:

- Surface pan vibrators that ride over the top of the pavement.
- Internal type vibrators, sometimes called spuds, are immersed into the concrete.

Vibrators may be attached to the finishing machine, the spreader, or mounted on a separate carriage. Requirements associated with equipment mounted vibrators are included in **SS 508.04**.

The Technician needs to be aware of the light or other warning device attached to each vibrator circuit on formed equipment that indicates failure of an individual vibrator. When failure occurs, the Technician should inform the Contractor's foreman of the problem. If the Contractor does not take corrective action within a reasonable timeframe, the Technician should inform the PEMS as soon as possible.

HAND EQUIPMENT

There are many hand tools available for concrete work and each has a specific use. The most common hand tools used are floats and trowels. A wide float of at least 5' in length and 6 in in width is used to remove longitudinal imperfections in the pavement. Smaller floats may be used for other types of irregularities. Trowels are used to obtain very smooth surfaces as may be required on a sleeper slab, which is the support slab under a terminal joint.

A finisher may use a wide assortment of small floats and trowels along the edge of the pavement and at expansion and butt joints. These may also be required for finishing around manholes, inlets, etc.

10 FOOT STRAIGHTEDGE

A 10-foot straightedge (Figure 4-8) with a handle 3 ft longer than half of the width of the pavement is used last to remove any longitudinal imperfections or surplus water from the surface.



Figure 4-8 10 ft. Straightedge

TINING

Tining is the required method for final finishing. This procedure is normally done with a power-driven tining device, making uniform transverse grooves in plastic concrete. A hand tool with steel tines (Figure 4-9) may otherwise be used on ramps, connections, and other miscellaneous areas where using mechanical tining equipment is not practical.



Figure 4-9 Steel Tine Hand Tool

HANDHELD VIBRATORS

Handheld vibrators (Figure 4-10) are required to have a head diameter of 1 ¼ to 2 ½ in and be capable of 7000 to 10,800 impulses per minute in air. The vibrators may be used in areas where the machine mounted vibrators cannot reach, such as at joints or around manholes and inlets.



Figure 4-10 Handheld Vibrator

SAWS

Self-propelled single (Figure 4-11) or gang-mounted concrete saws are used to saw joints to the proper width and depth. These saws usually have small lights attached to them since much of the time they are used during night-time hours after the concrete have been poured. The required depth and alignment of the cuts is required to be done without damaging the concrete.



Figure 4-11 Sawing joints into concrete

FORMS

When a standard finishing machine is used, forms are required to be set to the proper line and grade. Forms are a minimum of 10 ft in length and are required to have a depth of at least the pavement thickness. The base of the form is as wide as the depth of the form. The forms are fastened end to end and to the subgrade with at least three form pins and wedges and are required to be locked tightly to each other.

CHAPTER FIVE: *SETTING FORMS*

Since the quality and placement of the forms directly affects the quality of the pavement, subbase support, alignment, and general fitness of the forms is essential. The Technician needs to pay close attention to the allowable form tolerances and the methods of securing the forms to the subbase. Typically, forms are only used for miscellaneous pours at pavement gaps (Figure 5-1) necessitated by traffic control requirements at intersections and driveways or locations where intersection or driveway geometrics make slip-form paving impractical.



Figure 5-1 Form Paving

For QC/QA PCCP, form placement shall be per **SS 508.04**. For PCCP, these requirements are included in **SS 502.09**.

Additionally, if the Contractor is employing a slip-form paver in its paving operation, there should be forms available for the paving crew to utilize if edge slump problems develop.

FORM FITNESS

When paving is done with a finishing machine, the form setting operation is critical. (Figure 5-2) As the forming process begins, each pavement form needs to be examined by the Technician. These forms have often been used for several years and may be in poor condition. The top edge of the forms represents the top surface of the pavement. If the form has a dip, the pavement will likely have a dip as well. Any form that varies by more than $\frac{1}{8}$ in in 10 ft along the top edge of the form or $\frac{1}{4}$ in in 10 ft along the face cannot be used.

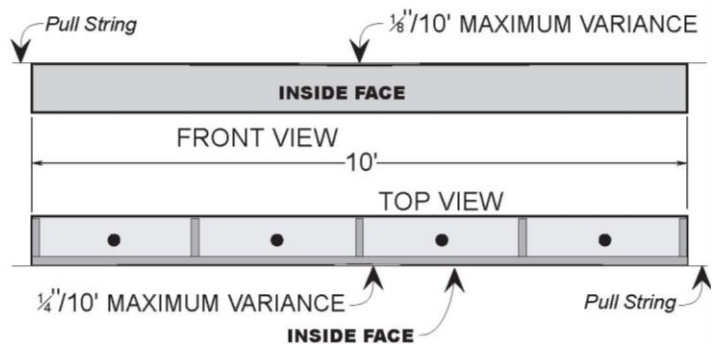

Figure 5-2 Allowable Form Variance

Forms that are no longer capable of being securely pinned and locked are not used. If the Contractor elects to repair rejected forms, they are required to be re-inspected before use.

If deficient forms are found, the Technician should bring the matter to the attention of the Contractor's paving foreman. If the Contractor fails to take the appropriate corrective action in a reasonable timeframe, the Technician needs to inform the PEMS as soon as possible.

SUBBASE SUPPORT

The subbase under the forms is required to be firm, constructed to grade, and make 100% contact with the bottom of the form. Any variations in the form line are required to be corrected.

FORM SETTING

After the forms have been set to the proper line and grade, the subbase is required to be tamped along the inside and outside edges of the forms.

Steel forms are required to have three form pins securing the form to the ground. Two of these pins are placed at the ends of the form. Wood forms require sufficient pins to prevent deflection of the forms while supporting the finishing equipment. Each form is locked to the next form and is required to be free from play or movement in any direction. All forms are cleaned and oiled before concrete is placed. The Technician is required to verify that all pin locks are secure.

GRADE AND ALIGNMENT

Before placing the concrete, form alignment and grade are compared to grade stakes. Any variation of $\frac{1}{8}$ in or more from the proper grade is required to be corrected. Likewise, any variation along the face of the forms of $\frac{1}{4}$ in or more also is corrected. The forms are checked for stability at this time. The Technician needs to inform the PEMS as soon as possible if the Contractor fails to take corrective action in a reasonable timeframe.

If possible, forms should be prepared at least 500 ft ahead of concrete placement. If the material under the forms becomes unstable, the affected forms are required to be removed and the subbase repaired.

CHAPTER SIX: *THE PAVING OPERATION*

Once the subbase has been checked for true line and grade, the paving operation may begin. The paving operation is a straightforward and systematic series of steps. This chapter covers each step in the paving operation and explains why each is necessary for a quality product. The following topics are discussed:

1. Checking the condition of the subbase
2. Checking placement of the tie bars and dowel bar assemblies
3. Mixing and placing concrete
4. Finishing and curing concrete
5. Observing weather restrictions

In general, the following discussion applies to both QC/QA PCCP and PCCP. If any specifics only apply to one pavement type, it will be noted in the discussion.

CONDITION OF SUBBASE

The subbase is required to be maintained in a smooth and compacted condition up to the time paving begins. A dry subbase will absorb moisture from the concrete. Therefore, the subbase is required to be uniformly moist when the concrete is placed. Spraying water on the subbase ahead of the paving operation may be necessary (Figure 6-1). The Technician needs to ensure that the watering operation does not create mud or pools of water on the subbase. If either of



Figure 6-1 Subbase Watering

these situations occurs, the Technician needs to discuss the problem with the Contractor's paving foreman. If the problem persists, the Technician needs to inform the PEMS as soon as possible.

The subgrade or subbase shall be uniformly moist at the time of PCCP placement. Excessively dry subgrade or subbase shall be sprinkled with water.

DOWEL BARS AND ASSEMBLIES

Dowel bars are smooth, epoxy coated, steel bars which are placed at all transverse joints to provide load transfer across the joints. Dowel bars allow the pavement to slide freely at the joint while expansion and contraction is occurring. When the dowel bars are used for expansion joints, the free end of each bar has an expansion tube attached to the bar.

Generally, dowel bars are mounted in a welded wire basket referred to as a dowel bar assembly (Figure 6-2). This assembly holds all the dowel bars evenly and securely in place, so they do not shift horizontally or vertically during the paving operation.

The entire assembly is secured to the subbase with pins. Sufficient pins to secure the assemblies to the subbase must be provided.

Dowel bars are required to be inspected for vertical and horizontal alignment before paving by the Technician. The recommended frequency for alignment verification is at least one for every 2000 feet of pavement. If the Technician witness movement of the dowel bar assemblies during the paving operation, a dowel bar check must be performed after the concrete has been placed. If this is required, the concrete is removed from the ends of each dowel bar on the assembly and each bar is checked. This procedure is done quickly because any correction is required to be made while the concrete is still plastic.



Figure 6-2 Dowel Bar Assembly

Vertical alignment may be checked with a dowel bar checker (Figure 6-3). This device is first placed on the form or subbase next to the basket being checked, and the bubble is leveled to conform to the grade. Each dowel is then checked. If the bubble is not in the center, one leg of the checker is lifted until the bubble is in the center. If the required change is more than $\frac{1}{4}$ in, the dowel bar vertical alignment is required to be corrected.



Figure 6-3 Dowel Bar Checker

Horizontal alignment is checked by measuring the distance from each end of the dowel to the form or string line and comparing the two measurements. If they differ by more than $\frac{3}{8}$ in, the horizontal alignment must be corrected.

All dowel bar checks are documented by the Technician and these records are included in the contract file.

Prior to placing concrete, individual dowel bars are coated with an approved material to break the bond with the concrete.

SS 503 includes requirements associated with dowel bar assemblies.

MIXING CONCRETE

Concrete may be mixed in any of the following ways:

- On site mixers (these mixers are rarely used and are not discussed)
- Central mix plants
- Ready-mix plants using transit mixers

For QC/QA PCCP, the concrete mixing time will be in accordance with the Contractor's QCP. If the Technician observes concrete associated with QC/QA PCCP being placed that does not appear to be uniformly mixed, slump tests as described in Chapter Three: Concrete Job Control and **SS 501.14** should be performed.

For PCCP, the concrete mixing time requirements are included in **SS 502.10**. When transit mixers are used, the Technician needs to witness the mixer drum complete the required number of revolutions prior to placement. Again, if the concrete does not appear to be mixed thoroughly at the time of placement, the Technician should perform slump tests as described in this manual and **SS 502.10**.

Water may need to be added to transit mix concrete at the paving site. When concrete is delivered in transit mixers, additional water to increase the workability of a load may be added within 45 minutes of initial mixing. If the proper slump cannot be achieved within these time

constraints, the Technician should notify the PEMS as soon as possible. If adding water to the concrete trucks becomes routine, a correction is required to be made in the amount of water being added at the plant. The amount of water added is noted on the concrete tickets (Figure 6-4) for the concrete record.

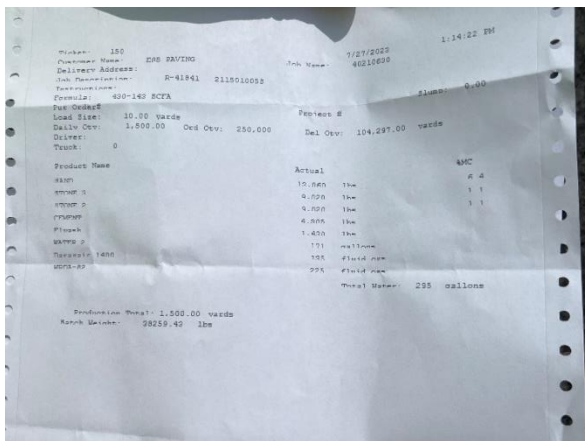

Figure 6-4 Concrete Ticket, paper form

Concrete is required to be placed in a timely manner. The time requirements for mixes used for QC/QA PCCP are included in **SS 501.14** and the requirements for mixes used for PCCP are included in **SS 502.10**. In order to enforce these requirements, the Technician needs to refer to the mixing time shown on the concrete ticket, recognize the

type of truck used to haul the concrete, and be aware of the temperature of the concrete.

As temperatures vary, the workability of the concrete mix used in the pavement construction varies as well. The Contractor may elect to utilize chemical admixtures or other means to improve concrete workability. The Technician needs to be aware of the concrete mix design requirements in **SS 501.04** for QC/QA PCCP or **SS 502.03** for PCCP. In general, for QC/QA PCCP, new admixtures require new mix designs while changes in admixture dosage rates or a change in the source of a previously approved admixture do not require a new mix design. For PCCP, new admixtures, deletion of currently approved admixtures, as well as a change in source of a previously approved admixture require a new mix design. A change in the dosage rate of a previously approved admixture does not require a new CMD.

WEATHER RESTRICTIONS

Sufficient lighting is required for the concrete paving operations. If paving is performed during nighttime hours, lighting is used so that all operations are visible.

Weather limitations for QC/QA PCCP operations are included in **SS 501.15**. PCCP shall be placed when the ambient temperature is 32° F and rising. It shall not be placed on frozen subgrade or subbase. When the ambient temperature is at or below 40° F during PCCP placement, the cold weather plan shall be followed as outlined in the QCP in accordance with **SS 501.02**.

PCCP weather limitations are included in **SS 502.11**. PCCP shall not be placed on frozen subgrade or subbase. PCCP shall not begin until the ambient temperature is 35°F and rising. PCCP operations shall be discontinued when the ambient temperature is descending and is 40°F or below. In order to enforce the applicable specification requirements, the Technician must be able to determine the air temperature during the paving operation, inspect the subbase to verify that aggregate material has not frozen, and after the concrete has been placed verify that the newly constructed pavement is not allowed to freeze prior to attaining strength necessary to open the pavement to traffic.

PLACING CONCRETE

For QC/QA PCCP, the requirements for placing concrete are included in **SS 501.16**. Similar requirements for PCCP are included in **SS 502.12**.

Sufficient equipment and material supplies are required to be kept on hand to allow for a continuous operation. The timing of concrete delivery is critical to the quality of the pavement, especially for slip-form paving. Every time that the paving train stops, there is potential for any number of deficiencies to be introduced in the pavement.

Precautions may be necessary to prevent segregation of the concrete during the placement operation. Segregation occurs when fine and coarse aggregate particles within portions of the concrete mix are separated from each other. A segregated mix will appear non-uniform as there will be noticeable voids between coarse aggregate particles at some locations and other portions of the mix will only have fine aggregate particles visible. After placing, concrete should be handled as little as possible to minimize the risk of additional segregation. Any handling should be done by a machine or with a shovel instead of rakes. Equipment made of, or coated with, aluminum or aluminum alloy is not allowed to be used to place or transport concrete. All workers walking on the fresh concrete during placement are required to keep their footwear free of foreign material that may contaminate the fresh concrete.

Caution must be taken by all workers to not disturb joints and dowel bar assemblies. Machine mounted vibrators may have to be lifted to avoid joints, manhole castings, and other possible obstructions. Handheld vibrators are required to be used to consolidate the concrete in these areas as well as any other location that may not be accessible to the machine mounted vibrators. Consolidating the concrete against the faces of all forms and joints is important.

Vibrators should be inserted in a fluid continuous motion and are not to be used in any one spot for more than a few seconds. Vibrators may never come into direct contact with the side forms, joint assemblies, or the subbase.

All castings associated with manholes and similar structures are required to be adjusted to the proper grade and surrounded with preformed joint material before paving begins. This step is very important as numerous pavement failures have been experienced at these locations. The Technician needs to communicate with the Contractor's paving foreman if joint filler material is not used to isolate the casting from the pavement. If corrective action is not taken in a timely manner, the Technician needs to inform the PEMS as soon as possible.

Another element of the concrete paving operation that the Technician needs to watch is how the operation affects adjacent pavement which is to remain in place. Common problems that the Technician needs to look for include damage to adjacent pavement edges due to paving train equipment, damage to adjacent pavement from the newly constructed pavement joint sawing operation, as well as failure to remove concrete or other debris generated by the paving operation from adjacent pavement joints. If cement mortar or other incompressible materials are not removed from the joints in the adjacent pavement, the pavement cannot contract as intended and the concrete on either side of the joint may pop out. The Technician must report any damage to adjacent pavement to the PEMS as soon as possible as the Contractor is responsible for repairing all damaged areas.

PLACING REINFORCING STEEL

The concrete is deposited on the subbase and spread by a mechanical spreader which also strikes the concrete off to the proper elevation. Concrete is kept in front of the strike off at all times to prevent depressions in the pavement.

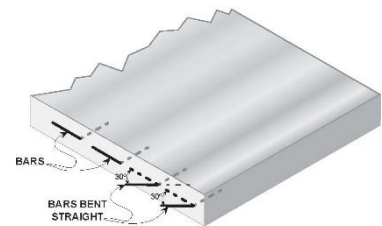

Figure 6-5 Tie Bar Placement

Reinforcing tie bars for longitudinal joints may be inserted into the concrete automatically by the paver. The purpose for the tie bars is to ensure that all lanes in a pavement expand and contract in a unified manner. When paving two lanes at once, a straight tie bar is inserted every 3 ft along the longitudinal joint by the paver. If an adjacent lane is to be paved later, tie bars are inserted into the edge of the pavement at 30 degrees to the perpendicular and bent straight after the concrete has set (Figure 6-5). If more than one of the deformed bars in a panel break or become dislodged during straightening, all broken or dislodged bars are replaced with retrofitted tie bars.

All tie bars are required to be free from dirt, harmful rust, scale, paint, grease, oil, or anything else that may prevent the concrete from bonding to the steel.

STRIKE-OFF, CONSOLIDATION, AND FINISHING

The paving equipment is designed to properly strike off, consolidate, and finish the concrete accurately to the required elevation and cross section. For this to occur, a sufficient amount of concrete is required to be carried in front of the screed so that the paver is cutting the concrete at all times (Figure 6-6). All voids and depressions are filled if this procedure is used. The operation is controlled to ensure that an excess of mortar is not carried to the surface. If segregated particles come to the surface in front of the screed, they are required to be mixed back into the unfinished concrete by hand and not allowed to be pushed to the grade ahead of the concrete.



Figure 6-6 Paver Screed

When approaching a transverse expansion joint, concrete is poured over the joint ahead of the paver to provide stability to the joint assembly. The concrete around the joint is required to be properly consolidated to maintain the integrity of the joint. If the machine mounted vibrators or screeds are lifted to clear the joint assembly, consolidation may be done with handheld vibrators.

Hand methods of placing, compacting, and finishing (Figure 6-7) may only be used when finishing equipment breaks down or in areas where finishing equipment cannot access. Concrete placed using hand methods must be floated using equipment included in **SS 508.08(a)**. Long handled floats used to smooth and fill in open texture areas in the pavement shall have blades no less than 5 ft in length and 6 in in width. Equipment made of or coated with aluminum or aluminum alloys shall not be used. Straightedges shall be 10 ft in length and mounted on a long handle. The handle shall be 3 ft longer than $\frac{1}{2}$ of the width of the pavement being placed.



Figure 6-7 Hand Finishing

When hand methods are required, the concrete is placed above the required grade and properly vibrated and struck off to obtain the desired results. If the width of the pavement is less than 4 ft, a simple board may be used to strike off the concrete after hand vibration. Wider pavements require a vibratory strike-off board. Bridge deck type finishers may also be used.

FLOATING

After proper strike-off and consolidation, the pavement is finished further by floating. This procedure may be done with a mechanical float which consists of large rollers which spin as they are moved across the surface. If specifically allowed, a hand float (Figure 6-8) of no less than 14 feet in length may be used. If the Technician notes a rough surface on a pavement finished with a hand float, the hand float should be checked for distortions. If distortions are noted the Technician should inform the Contractor's paving foreman. If corrective action is not taken in a timely manner, the Technician needs to inform the PEMS immediately.



Figure 6-8 Floating

Floating is required to be continuous from edge to edge. When hand floating, a work bridge may be required for the finisher to walk upon.

Smaller floats of no less than 5 feet in length may be used to correct surface blemishes or irregularities.

CHECKING FINISH AND SURFACE CORRECTIONS

When the final floating is complete, a long handled 10 ft straightedge is pulled across the concrete to remove any surface irregularities, surplus water, or inert material that may be present from the previous operations. This is the last opportunity to make corrections to the pavement and is an important process to assure pavement smoothness.

Once the straight edging is complete, per **RSP 504-R-757**, an initial surface texture is created by dragging a double thickness of burlap or a minimum 4 ft wide turf drag followed by tining oriented either longitudinal or transverse to the direction of travel as specified herein, all before the PCCP permanently sets. Now the pavement is ready for tining.

TINING

The final finish for the pavement is achieved by tining which is a process of placing grooves in the pavement to aid in skid resistance. This is done by a mechanical device shall have horizontal and vertical controls to ensure the forming of straight grooves of uniform depth and alignment in the plastic PCCP, without tearing the surface. Tining of the pavement will be either longitudinal or transverse direction.



Figure 6-9 Longitudinal Tining

Longitudinal Tining (Figure 6-9) is placed parallel with the direction of travel with 1/8 in wide tines, paced at

3/4 in. center-to-center, and produces a uniform, nominal depth tine groove 1/8 in. to 3/16 in. deep. The mechanical device should be able to tine the full width of the pavement in one operation. Tining will be restricted from taking place within 3 in of pavement edges or longitudinal joints.

Transverse Tining (Figure 6-10) is placed on PCCP perpendicular to the direction of travel on all approaches, ramps, tapered areas, and gores. This type of tining will have 1/8" wide tines spaced center-to-center as follows: 3/8", 9/16", 5/8", 7/16", 3/8", 1/2", 9/16", 5/8", 7/16", 3/8", 13/16", 1/2". These must produce a uniform, nominal depth tine groove 1/8" to 3/16" deep.



Figure 6-10 Machine Transverse Tining

Tining may be done manually on ramps, intersection radii or other miscellaneous areas where mechanical devices cannot be used. Tining grooves are required to be either longitudinal or transverse per applicable usage. Timing is very important for the tining process. If done too soon, the grooves may be too deep or may close up. If done too late, the grooves may not be deep enough.

When the latter occurs, grooves are required to be cut into the concrete by machine after the pavement hardens completely.

EDGING

All edges of slabs and formed joints are required to be rounded to the radius indicated in the plans. This procedure is accomplished using a finishing tool called an edger (Figure 6-11).

Any tool marks left behind by the edger are removed before the burlap drag is used. All joints are checked with a straightedge to verify that no side of the joint is higher than the other. Corrections are required to be made immediately.



Figure 6-11 Hand Finishing Pavement Edge

EDGE SLUMP

When the slip-form method is used, special attention is placed on the edge slump. The edge slump is defined as how far the edge of the wet concrete pavement slumps down after the slip-form paver has passed.

For QC/QA PCCP, there are no requirements associated with edge slump (Figure 6-12). However, the QCP should address how the Contractor intends to monitor edge slump during the paving operation. For PCCP, edge slump shall not exceed $\frac{1}{4}$ in which is included in **SS 502.09**. Regardless of the type of pavement, edge slump is corrected by placing a form next to the pavement with the deficient edge slump for support. The Technician should ensure that the Contractor has sufficient forms on hand prior to the start of the paving operation and that the forms are used when the pavement has edge slump problems. The Technician should discuss any edge slump related deficiencies with the Contractor paving foreman. If appropriate corrective action is not taken, notify the PEMS as soon as possible.

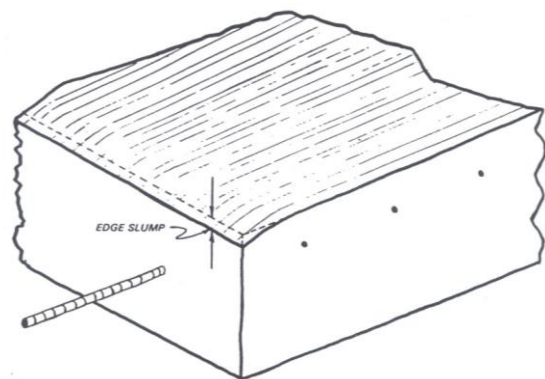

Figure 6-12 Edge Slump

PAVEMENT DATES AND STATIONS

The Technician is responsible for placing the date and station numbers on the pavement. This is done immediately after tining, while the concrete is still plastic. This provides a permanent record of stationing along the pavement as well as a history of when the paving was performed.



Figure 6-13 Pavement Stationing

Cast iron dies are used to place the date and the plus station at the beginning of each day's run. Full stations are also stamped every 100 feet (Figure 6-13).

Station numbers are to be stamped on the right side of the pavement with the nearest digit approximately 8 in from the edge of the pavement (Figure 6-14).

In the case of multiple lanes, the station numbers are placed along the outside edge of the pavement, readable from the same direction as the flow of traffic.

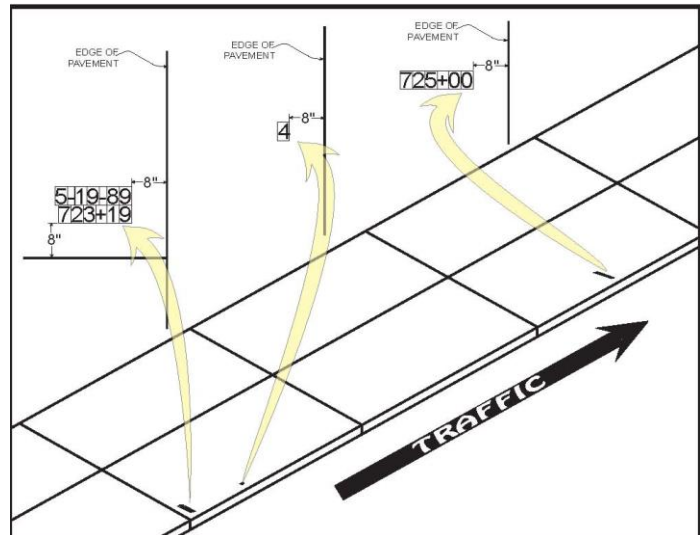

Figure 6-14 Pavement Stamp Location

CURING

Curing is as important to the integrity of the pavement as anything previously discussed. For proper curing, the pavement is required to retain moisture and be kept from freezing. Curing requirements are included in **SS 504.04**. Curing materials shall be applied to exposed surfaces and sides of newly placed PCCP within 30 minutes after the finishing operations have been completed, or as soon as marring of the concrete does not occur. The Technician is responsible for monitoring the pavement throughout the required curing period. Depending on the curing method employed, the Technician may have to inspect the pavement on a daily or more frequent basis throughout the curing period to ensure that any covering media remain in place. Wind is the primary cause for displacement of covering media during the curing period. As soon as possible after a wind event, the Technician needs to check all pavement that is curing to verify that the covering media remain in place.

For formed pavement, if the Contractor removes the forms within the curing period, the Technician needs to verify that the newly exposed pavement edges are cured throughout the remainder of the curing period.

If the pavement is not cured properly, its strength and durability will be compromised. This will result in additional maintenance and a reduced service life for the pavement.

The methods used to retain moisture in the concrete include:

- Liquid membrane forming compound, or more commonly, curing compound (Figure 6-15)
- Two layers of wet burlap
- Waterproof covers



Figure 6-15 Liquid Membrane Application

The compound shall be applied in two applications of a continuous uniform film at a rate not less than 1 gal/150 ft² for each application. If there is a possibility of freezing during the curing period, the concrete pavement is further protected by a suitable covering of straw or blankets. During this period, the Technician must perform temperature checks under the covering at the pavement surface and record for the contract record. If the checks indicate that the pavement is being subjected to freezing temperatures, inform the PEMS as soon as possible.

PROTECTION FROM RAIN

Rain may be very detrimental to unhardened concrete pavement and measures are required to be taken by the Contractor to protect the pavement from this occurrence. The Contractor is required to have materials available at all times to protect the pavement in the event of an unexpected rain. If rain begins to fall, all available Contractor personnel are utilized to place a protective covering, usually plastic sheeting, on the pavement. Planks or forms are also required to be available to protect the edges of the pavement when slip-form paving.

If the Technician believes that a rain event is about to occur while the paving operation is ongoing, the PEMS should be contacted as soon as possible. The PEMS and the Contractor Superintendent will be responsible for deciding whether a suspension of the paving operation due to the weather conditions is warranted.

REMOVAL OF FORMS

For QC/QA PCCP, requirements for form removal are included in **SS 501.21**. For PCCP, form removal requirements are included in **SS 502.16**. Forms may be removed as soon as the PCCP has hardened sufficiently to prevent edge spalling or other damage. Form pullers shall not be supported on the PCCP during form removal operations.

The Technician needs to inspect the pavement edges while the forms are being removed or as soon as possible afterward and inform the PEMS of any damage.

CHAPTER SEVEN: *PAVEMENT JOINTS*

Pavement joints are vital to control concrete pavement cracking and movement. Without joints, most concrete pavements would be riddled with cracks within one or two years after placement. Water, ice, salt, and loads would eventually cause differential settlement and premature pavement failures. These same effects may be caused by incorrectly placed or poorly designed pavement joints. The Technician is responsible for inspecting all joints to avoid the problems associated with joint failure.

Pavement joint locations are typically not shown on the plans. Therefore, it is the responsibility of the Contractor to determine the joint locations.

Forethought should be given to the design and placement of the pavement joints so that the end result is a properly functioning pavement system. Special attention is required at intersecting approaches, turn lanes and crossovers so that the joints required at these locations can be aligned with those in the mainline pavement. "Dead ending" of joints in the middle of adjacent slabs is avoided whenever possible to prevent a crack developing in the adjacent slab as an extension of the mainline joint.

An example of a well-planned joint design is shown in Figure 7-1. The joints in this diagram are continuous from edge of pavement to edge of pavement. Also, the joints in the mainline pavement are aligned to serve the joints in the adjoining pavements.

The following pavement joints and related materials are discussed:

- Construction joints
- D-1 contraction joints
- Longitudinal joints
- Transverse construction joints
- Terminal joints
- Expansion joints
- Retrofitted tie bars

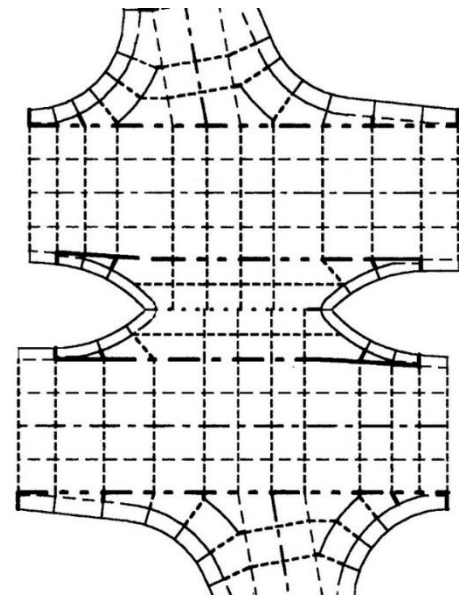

Figure 7-1 Pavement Joint Layout

TYPES OF JOINTS

There are many types of joints used in the construction of concrete pavements, but they all control the movement of the pavement and the associated cracking and/or differential settlement.

Longitudinal joints are constructed parallel to the center line, and transverse joints are constructed perpendicularly to the center line of the pavement. Understanding the use and function of the different types of joints is required in determining their placement.

CONSTRUCTION JOINTS

Some longitudinal and transverse joints are placed in the pavement in order to control cracking as discussed above. Other longitudinal and transverse joints are required because of limitations on the construction operation and the construction equipment. These joints are referred to as construction joints. For most contracts, it is not possible for the Contractor to produce and deliver sufficient concrete to construct all the pavement required for a project in a single day. Therefore, at the end of each day a transverse construction joint is constructed from which the paving operation will begin the following workday. Also, in many situations a project will require that a Contractor construct a pavement that is wider than the available paving equipment can produce. In these situations, a longitudinal construction joint is constructed along a lane line over the entire length of the pavement. The lane adjacent to this longitudinal construction joint will be built at a later date.

D-1 CONTRACTION JOINTS

D-1 contraction joint requirements are included in **SS 503.03(a)**.

Typically, a contraction joint is a sawed transverse joint normally placed at a spacing shown on the plans to control cracking due to pavement contraction caused by concrete shrinkage and temperature fluctuations. The sawed contraction joint shall not exceed 18 ft apart.

A dowel bar assembly (Figure 7-2), commonly called a basket, is secured to the subbase before paving at the location of each contraction joint. The Technician is responsible for verifying that the dowel bar assemblies are installed at the appropriate spacing. The steel bars of this assembly, or dowel bars, are large and, once incorporated into the concrete pavement, transfer the vehicular load from one slab to another, eliminating differential settlement known as faulting at the joint.



Figure 7-2 Dowel Bar Assemblies

The location of the center of each dowel bar assembly is marked by Contractor personnel outside of the form/slab line so that the dowel bar assembly may be located once the pavement is in place. This is necessary so that the joint saw cut will be made in the proper location. These markings must be maintained during and after the paving operation because the markings may easily become disturbed during construction.

The Technician is also required to monitor the locations of the tie-bar reinforcing steel to ensure that the tie bars do not interfere with the operation of the D-1 joint. Tie bars placed within the limits of a dowel bar assembly must be adjusted longitudinally so that they do not hamper the movement designed into the joint.

The longitudinal adjustment required is seldom more than 1 ft (Figure 7-3) and is accomplished by installing a retrofitted tie-bar.

After paving, the previously designated centerline locations of the dowel bar assemblies are utilized to mark the joint saw cut on the pavement and the saw cut is made for the joint. Timing is critical when making this saw cut on contraction joints. If sawed too soon, the joint spalls and ravel. If sawed too late, the pavement may have already cracked randomly. For this reason, the sawing of joints often starts within 2 to 12 hours of the time of concrete placement, depending upon the ambient/material temperature, humidity, and wind conditions. The sawing of a pavement continues, night and day, regardless of weather conditions until complete. If random cracking is observed ahead of current sawing operations, the sawing operation is advanced until the random cracking is controlled. The joint is required to be sawed straight for the full depth, width, and length of the joint. The Technician is responsible for checking these requirements. Because of the importance of the sawing operation, the Technician should not hesitate to contact the PEMS with any questions or if any problems arise.



Figure 7-3 Tie Bar Adjustment at Dowel Bar Assembly

If slurry created by the sawing operation settles in the saw cut, this material is required to be flushed with high pressure water to remove the slurry from the entire depth of the joint. Care is taken not to damage the pavement while flushing because the concrete is still "green" and vulnerable to damage from excessive force. If the slurry is not removed from the joint, this material hardens, and the joint is required to be re-sawed.

Just prior to sealing, the joint is cleaned, with a jet of compressed air or otherwise, to remove all foreign material and prepare the joint faces for the sealer. It is important that the joint faces be dry and clean prior to application of the joint sealer. All joints and cracks in the PCCP shall be cleaned and sealed in accordance with the sealant manufacturer's recommendations and following **RSP 503-R-749**'s revision to **SS 503.05**. The surface of the sealer must be below the surface of the pavement so that traffic does not damage or pull out the material. Also, the thickness of the sealer thickness is critical to ensure the elasticity of the sealer is maintained. **SS 503.05** and **Standard Drawing 503-CCPJ-02** include requirements for joint seals.

The joint seal integrity plays an important role in the performance and service life of the concrete pavement. The seal is the only barrier that prevents water and de-icing chemicals from entering the pavement structure. This is especially important for joints located near the low point of sag vertical curves. If a joint seal fails, water and de-icing chemicals can saturate the joint. Over time concrete in the joint will deteriorate, usually beginning below the pavement surface and working its way up. This phenomenon has resulted in increased pavement maintenance costs and reduced pavement service lives. Therefore, the Technician must be diligent while inspecting the joint sawing and sealing operations to ensure that the seal material will perform as intended.

All joints must be sealed prior to opening a section of pavement to traffic or before the end of the current construction season. D-1 contraction joint instructions are found in **Standard Drawing 503-CCPJ-02**.

LONGITUDINAL JOINTS

A longitudinal joint (Figure 7-4) is required in all pavements wider than 16 feet. If two adjacent lanes are poured at the same time, a longitudinal joint is sawed along the lane line between the lanes.

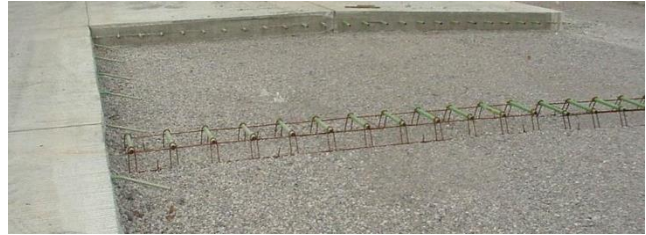

Figure 7-4 Longitudinal Joint

Tie bars between lanes placed at the same time are placed perpendicular to the longitudinal joint and parallel to the underlying subbase. Tie bars shall be machine placed during paving or secured with chairs prior to paving. When tie bars are required along the form line or the edge of a slip-formed lane, bent bars are used. Bent bars are tie bars bent at a 60° angle (Figure 7-5). These bars are straightened after the concrete sets so that they extend into an adjacent lane.

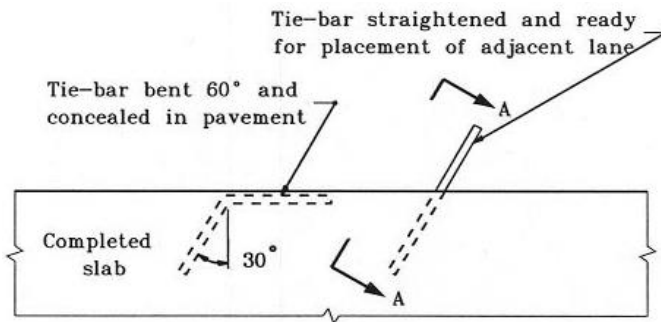

Figure 7-5 Tie-bar for Longitudinal Joint

Some longitudinal joints require the use of a keyway with no tie bars. Keyways (Figure 7-6) may be trapezoidal or semi-circular in shape. They are used when an adjacent pavement is expected to move independently, and the two pavements cannot be tied together. The keyway prevents any differential settlement of either pavement slab.

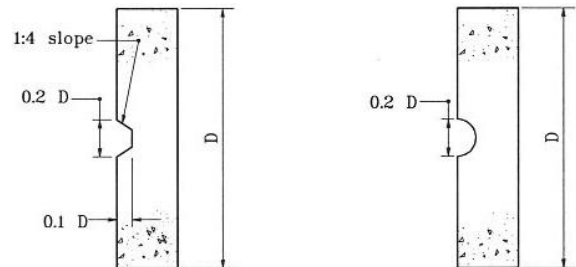

Figure 7-6 Keyway Joints

Longitudinal sawed joints are cut with a power concrete saw concurrently with the contraction joints. Requirements associated with longitudinal joints are included in **SS 503.03(b)**. Requirements associated with longitudinal construction joints are included in **SS 503.03(d)**. **Standard Drawing 503-CCPJ-02** illustrates the joint seal requirements.

Only one sawcut is required for longitudinal joints, same as the D-1 contraction joints. As is the case with the sawing and sealing operation for D-1 contraction joints, it is important that the sawcut edges are clean and dry prior to applying the joint seal material. Longitudinal joint seals that have failed have also resulted in the same type of pavement distresses and reduced service lives as was discussed earlier in this chapter for joint seals for D-1 contraction joints.

TRANSVERSE CONSTRUCTION JOINTS

A transverse construction joint is used when the paving operation is interrupted for longer than the maximum allowable time. These joints are commonly used at the end of the paving operation each day and may be retro-fitted to tie an existing slab to a new pavement. Transverse construction joints are required to be located as noted in **SS 503.03(c)** from an adjacent D-1 contraction joint.

Spacing of the tie bars in the transverse construction joint is required to be as shown on **Standard Drawing 503-CCPJ-04**. The tie bars are required to be epoxy coated and inserted through a header board set to the proper line and grade. Care is taken to assure that the bars are placed parallel to the subbase and the centerline.

If the transverse construction joint is retro-fitted, the existing pavement is drilled to accept the epoxy coated tie bars. The diameter of the drilled hole is required to be as recommended by the manufacturer of the approved chemical anchor system being used.

Requirements associated with transverse construction joints are found in **SS 503.03(c)** and **Standard Drawing 503-CCPJ-04**.

TERMINAL JOINTS

A terminal joint (Figure 7-7) is placed where a concrete pavement ends at a bridge or similar structure. **SS 503.03(e)** describes terminal joint detail.

The ends of the pavement and the reinforced concrete bridge approach are placed on a sleeper slab that has been previously poured. The sleeper slab is finished smooth and allowed to cure. A polyethylene sheet is placed over the slab prior to placing the pavement or reinforced concrete bridge approach. This sheet is a bond breaker, allowing the pavement and reinforced concrete bridge approach to move freely over the sleeper slab as they expand and contract. The gap between the pavement and the reinforced concrete bridge approach has a Pre-Compressed Foam Joint.

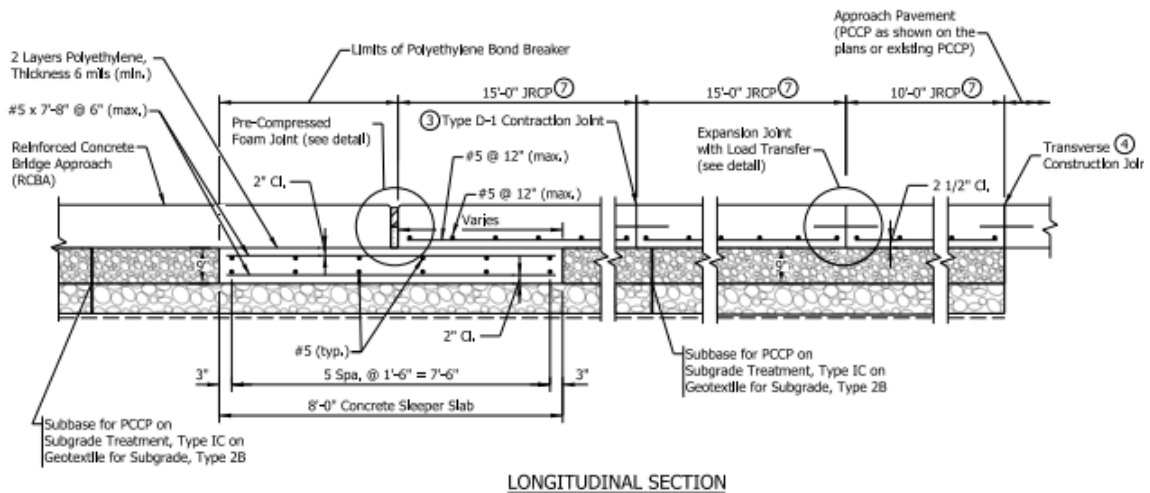

Figure 7-7 Terminal Joint

EXPANSION JOINTS

Requirements associated with expansion joints are included in **SS 503.03(f)**. Expansion joints shall be constructed at the locations shown on the plans and shall consist of joint filler. The joint filler shall be shaped to the subgrade, parallel to the surface, and be full width of the pavement. Damaged or repaired joint filler shall not be used. The joint filler shall be held in a position which is normal to the surface. The purpose of an expansion joint is to account for expansion of the concrete pavement. If expansion joints are not utilized, the concrete pavement would essentially crush itself as it expands.

RETRO-FITTED TIE BARS

When new pavement is to be tied to an existing pavement, tie bars are used to tie the pavements together. The requirements associated with retro-fitted tie bars are included in **SS 503.03(g)**. Retrofitted tie bars shall be secured at right angles to the pavement with a chemical anchor system in accordance with the manufacturer's recommendation. The chemical anchor system shall be injected to the back of the hole to eliminate air pockets prior to inserting the bar. The quantity of material injected shall be sufficient to disperse the material along the entire length of the bar and completely fill the annular space. After the anchor system has been injected, the bar shall be fully inserted using a back-and-forth twisting motion, leaving the proper length exposed. Once the adjacent pavement has been poured, the joint is sawed and sealed the same procedure as required for a construction joint.

CHAPTER EIGHT: *MISCELLANEOUS PAVEMENT DETAILS AND REQUIREMENTS*

EAR CONSTRUCTION

Ear construction (**Standard Drawings E605-ERCN-01** and **E605-ERCN-02**) is required wherever concrete pavement tapers to or from a point. Tapers are usually utilized at ramps, turn lanes, and other facilities designed to allow traffic to accelerate or decelerate prior to making a turning movement. If the concrete were constructed to taper to a point, it would shear off under the weight of traffic. Ear construction utilizes a minimum width of 1 ft with reinforcing steel to prevent shear failure.

Ear construction uses an expansion joint to isolate it from the remainder of the tapered pavement. It is also tied to the adjacent mainline pavement so that it moves in unison with the mainline.

PAVEMENT SMOOTHNESS

After the concrete has cured enough to permit testing, the profile of the pavement is required to be checked for smoothness.

Smoothness may be checked one of three ways:

1. Inertial Profiler (Figure 8-1)
2. 16 ft straightedge
3. 10 ft straightedge

Inertial profilers are used on mainline QC/QA PCCP and adjacent acceleration or deceleration lanes meeting the requirements included in **501.25**. When an inertial profiler is used, results include areas of localized roughness and, at fixed intervals, the calculated International Roughness Index, or *IRI*.

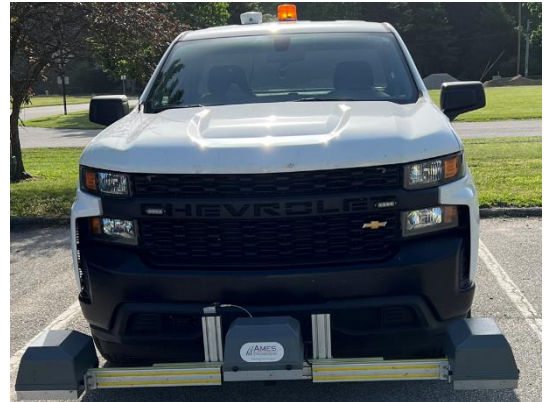

Figure 8-1 Inertial Profiler (attached to bumper)

Profile smoothness is checked with a 16 ft straightedge on all PCCP pavements and on QC/QA PCCP pavements that meet the requirements contained in **SS 501.25(b)**. The straightedge is positioned 3 ft from and parallel to the outside edge of each lane up to 12 ft wide. Lanes wider than 12 feet are checked 3 ft from both edges. Any liquid membrane forming compound removed during the straightedge operation should be replaced immediately. The 10 ft straightedge is used on transverse slopes, approaches, and crossovers.

When correction is needed, a groove type cutter is used to grind the pavement to the proper smoothness. If the grinding operation reduces the tining grooves to a depth of less than 1/16 in and the longitudinal length of the removal area exceeds 15 ft, or two or more areas are within 30 ft of each other, the PCCP shall be re-textured in accordance with **SS 504.03**.

The required surface tolerances for PCCP are:

- 16 ft straightedge – ¼ in or less
- 10 ft straightedge – ⅛ in or less

The required surface tolerances for QC/QA PCCP are:

- Inertial Profiler – all areas with a localized roughness <160 in/mi utilizing continuous IRI with a 25 ft window shall be corrected, subject to approval by the Engineer
- 16 ft straightedge – ¼ in or less
- 10 ft straightedge – ⅛ in or less

An IRI value greater than 190 in/mi shall require full depth removal and replacement of sufficient area to meet specifications. After the corrective action is complete, the inertial profiler shall be operated throughout the entire affected smoothness section to verify the adequacy of the corrective action. Additional information related to corrective action for smoothness can be found in Chapter Ten: QC/QA PCCP and PCCP.

PROTECTION OF PAVEMENT

Until final acceptance of the new pavement, the Contractor is responsible for protecting the pavement against damage. This protection may require barricades, watchmen, lights, crossovers, or a number of other measures. All damaged pavement prior to final acceptance is required to be repaired or replaced.

OPENING PAVEMENT TO TRAFFIC

CONSTRUCTION VEHICLES, EQUIPMENT, AND TRAFFIC

Newly constructed pavement shall not be subjected to loading from Contractor equipment, vehicles, or traffic until the requirements included in **SS 501.23** are met for QC/QA PCCP or **SS 502.18** for PCCP. Construction vehicles, equipment or traffic will be allowed on the PCCP when flexural tests indicate a modulus of rupture of 550 psi or greater. **ITM 402** may be used as an alternate method to determine the flexural strength. However, saws required to cut pavement joints are allowed on the pavement prior to the applicable above noted requirements are met. Prior to opening to traffic, cracks and joints shall be sealed in accordance with **SS 503.05** and the PCCP shall be cleaned. The Technician must inform the PEMS as soon as possible if Contractor vehicles, equipment, or traffic utilizes the pavement prior to the applicable requirements are met.

The minimum frequency for casting beams for determination of the modulus of rupture is included in the Manual for Frequency of Sampling and Testing. The Technician should discuss with the PEMS whether additional beams should be cast in situations where opening the newly constructed pavement to traffic as early as possible is necessary to maintain the required contract schedule. If the test beams do not indicate a minimum modulus of rupture of 550 psi within 14 calendar days of pavement construction, the Technician needs notify the PEMS as soon as possible.

Again, if the Technician becomes aware that Contractor equipment, vehicles or traffic are using the newly constructed pavement prior to the applicable requirements are met, the PEMS needs to be notified as soon as possible.

PAVEMENT THICKNESS

Concrete pavement is required to be constructed to the thickness specified in the contract. Before final acceptance, the actual thickness as constructed is determined from the measurement of cores drilled from the pavement.

CORING

Pavement thickness is determined at designated locations throughout the contract by obtaining cores after corrective grinding has been performed (Figure 8-2). The Contractor obtains these cores at the locations determined by the Technician per **ITM 802**. Cores are taken



for the full depth of the pavement thickness and are required to be 4 in in diameter.

The coring operation is witnessed by the Technician, who identifies, marks, and takes immediate custody of the cores. **SS 501.26** and **502.21** include limitations on locations where cores may be taken for QC/QA PCCP and PCCP, respectively.

Cores shall not be taken within 3" of longitudinal joints, within 2 ft of D-1 contraction joints, or within 5 ft of transverse joints. QC/QA PCCP requires cores not be taken within 6" of the edge of pavement, whereas PCCPs similar restriction is within 2 ft of the edge.

The required coring frequencies for QC/QA PCCP and PCCP can be found in the Manual for Frequency of Sampling and Testing.

Figure 8-2 Concrete Coring

After the coring operation is complete, the Technician needs to verify that the core holes shall be filled with PCC or rapid setting patch material within 24 h of drilling. This is important as it reduces the amount of water that enters the pavement structure.

CORE MEASUREMENTS

The length of each core is determined in accordance with **ITM 404**. Care must be taken when following the procedure, as paste associated with the concrete can attach itself to the aggregate from the underlying subbase, making it difficult to perform measurements.

DEFICIENT PAVEMENT THICKNESS

For QC/QA PCCP, the core lengths for the cores within a subplot are averaged and the average is compared to the pavement thickness required by the contract. A pay factor is determined in accordance with **SS 501.28(c)**. Sublots with an average core length which is less than the required pavement thickness will have a pay factor that is less than 1.00. The pay factor, when applied to the unit price and subplot quantity, results in a negative quality assurance, or QA, adjustment. More information regarding pay factors, lots and sublots is included in Chapter Ten: QC/QA PCCP and PCCP.

For PCCP, if a core measurement reveals that the pavement is more than ½ in deficient in thickness, additional cores are required in accordance with **SS 502.21**. These additional cores are required to determine the limits of the pavement that has deficient thickness. **SS 502.21(d)** and **502.21(e)** include discussions regarding non-payment or replacement of pavement found to have deficient thickness.

In summary, construction of pavements with deficient thickness results in either a reduction in pay due the Contractor or may require the Contractor to remove and replace the thin pavement. If removal and replacement of pavement is required, the Technician will be responsible for all job control testing and inspection for the new pavement as was the case for the original construction.

METHOD OF MEASUREMENT AND BASIS OF PAYMENT

Concrete pavement is measured and paid for by the square yard. The width is taken from the applicable typical cross sections on the plans and the length is measured along the center line of each lane or ramp. Paving exceptions which place gaps in the pavement are not measured. Payment for concrete pavement includes all materials not otherwise indicated in the contract as a pay item.

Retrofitted tie bars are paid separately for each bar, unless the bars are necessary to repair pavement that was damaged by the Contractor in one of the manners discussed in **SS 503.08**.

D-1 Contraction, expansion with load transfer, and terminal joints are measured and paid for by the linear foot. The cost of dowels, dowel bar assemblies, backer rod, joint sealants, and all necessary incidentals are included in the cost of the D-1 contraction joints.

The cost of the sleeper slab, reinforcing steel, bond breaker, pre-compressed foam joint, joint sealant, and all necessary incidentals are included in the cost of the terminal joint. When required, removal of an existing terminal joint and sleeper slab shall be included in the cost of the terminal joint

CHAPTER NINE: *CONCRETE PAVEMENT PATCHING*

Portland cement concrete pavement patching consists of the removal and replacement of unsound concrete, either full depth or partial depth.

MATERIALS

Materials used for PCCP patching include:

- Dowel bars
- Fine aggregate, size No. 23
- Coarse aggregate size No. 8, Class AP
- Coarse aggregate size No. 11, Class A or Higher
- Portland cement
- Water
- Calcium chloride, Type L
- Admixtures
- Chemical anchor systems

All materials must meet the requirements of **SS 506**, **SS 900** and the Approved Materials List.

The Technician should verify in the Contract Information Book, or *CIB*, that there are no Unique or Recurring Special Provisions (USPs or RSPs) included in the contract that might modify **SS 506** requirements. **SS 506** concrete mixes are aggressive and set up quickly. When used in a long patch, **SS 506** concrete can become difficult to work with and can be prone to random cracking shortly after construction. Therefore, in situations where long patches are required, the contract may require a less aggressive mix to improve the workability for the Contractor and minimize random cracking.

CONCRETE MIX DESIGN

The Concrete Mix Design process is covered extensively in Chapter 3: CMD Process.

Additionally, **SS 506.03** covers patching-specific differences, such as an alternate acceptance procedure allowing the Contractor to re-submit a CMDP accepted previously for a different use-case to the DTE for acceptance for patching. If the DTE accepts it, the CMDP is immediately approved for use without the need of a CMDS or Trial Batch process.

CONCRETE MIX CRITERIA

Concrete mix criteria requirements are established in **SS 506.04**, with **SS 506.04(a)** covering short patches and **SS 506.04(b)** covering long patches.

The primary difference in patching mixtures when compared to pavement mixtures is the inclusion of calcium chloride or additional cement to gain strength sooner than traditional concrete paving mixtures. This is needed to open newly-finished patched pavement to traffic within hours, in contrast with the days or longer allowed for new pavement to reach strength.

TRIAL BATCH DEMONSTRATION OF CMDS

Trial batch requirements are included in **SS 506.05**. The Technician will be involved in the performance of side-by-side sampling and testing along with Contractor personnel as is the case for trial batches associated with concrete pavement mixtures. This testing will be used to verify that the CMDS is able to produce a mixture that meets **SS 506.04** requirements. If the test results confirm the required performance of the CMDS, then the Technician will forward his or her test results to the Contractor for submittal to the DTE seeking approval of the resulting CMDP. The trial batch may be produced prior to construction in a laboratory, at the plant, or at the project site prior to the first day of production.

When first day production is used for the trial batch, production may continue until the flexural strength tests are completed. If the 24 hour or 3-day flexural strength tests fail to meet the requirements of **SS 506.04**, production must stop and a new CMDS must be developed and submitted. The patches associated with the failing test results will be subject to the failed materials process which is explained in more detail in *Chapter Ten: QC/QA PCCP and PCCP*.

ACCEPTANCE

Job control testing, including air content, relative yield, and flexural strength, is conducted by the Technician in accordance with **SS 505** and the Manual for Frequency of Sampling and Testing. When a test indicates that the material does not meet contract requirements, the Technician must notify the PEMS who is responsible for notifying the Contractor. Rounding of test results is required to be in accordance with **SS 109.01(a)**.

REMOVAL OF CONCRETE

There are two types of concrete patches—partial depth and full depth. The contract plans will include information related to the locations and types of patching required in the contract.

PARTIAL DEPTH PATCHES

The requirements associated with removal of existing concrete for a partial depth patch are in **SS 506.08(a)**. Saw cuts shall be a minimum depth of 1 in to a maximum depth of $\frac{1}{3}$ the thickness of existing pavement. Removal of all unsound concrete must be to a minimum depth of 2 in, and by hand chipping tools or mechanically driven handheld equipment. Mechanical hammers shall not be heavier than a nominal 45 lb class. Mechanically driven tools shall be operated at a maximum angle of 45° from the surface. If a saw cut face is damaged, a parallel saw cut 1 in outside the damaged saw cut shall be made and the concrete shall be removed by hand chipping.

The Technician's priorities while inspecting this work are as follows:

- Ensure all unsound concrete at the patch location is removed.
- Verify whether concrete removal requires a full depth patch.
- Watch for reinforcing steel exposed during removal operation.

In most cases, patches are located where the concrete pavement shows distress at the surface, and the decision to patch the pavement is made based on this surface distress. However, the

pavement distress may cover a larger area than indicated by the distressed surface. Also, the surface distress does not indicate the depth of damage to the existing pavement. Therefore, as the concrete removal operation is ongoing, it is always necessary to check the pavement for sound concrete. This can be done by dragging a chain or dropping a reinforcing bar on the remaining pavement. Sound concrete will produce what can be described as a solid sound while unsound concrete will produce a thud or a hollow sound when tested. It is important that, upon the completion of the concrete removal operation, only sound concrete remains.

For partial depth patching, the Technician needs to ensure that the depth of concrete removal is within the allowable range. If less than minimum depth is removed, the concrete patch will pop out. If the removal depth exceeds the maximum, there will be insufficient original sound concrete over the contraction joint dowel bars to facilitate load transfer. Eventually, the original concrete over the dowel bar will fail and the overlying partial depth patch will pop out.

If wire mesh reinforcing is exposed during the concrete removal operation, the exposed portion must be removed. If reinforcing bars are exposed, the partial depth patch must be replaced with full-depth patching in the area. If concrete is exposed below $\frac{1}{3}$ of the thickness of the existing pavement, the patch shall be changed to a full depth patch in accordance with **SS 506.08(b)**.

If the Technician observes that the maximum concrete removal depth is exceeded or that wire mesh reinforcing is exposed in conjunction with the removal of unsound concrete, the PEMS must be notified as soon as possible.

FULL DEPTH PATCHES

The removal requirements for full depth patches are included in **SS 506.08(b)**. Removal areas located in the same lane within 10 ft of each other require the PCCP between the areas to be removed and replaced as well. If a transverse joint is located within the removal area, the limits of removal are increased to a minimum of 1 ft beyond the joint. The Technician must verify that the concrete removal operation does not damage adjacent pavement. Common problems to watch for include saw cuts that extend into adjacent lanes or less-than-careful use of removal equipment, such as pavement breakers or hoe rams.

The Technician must be aware of requirements determining the minimum full depth patch length, and the minimum proximity of patches to each other within the same lane and to transverse joints. Normally, the limit of full depth removal continues outward from the patch location until sound concrete with sufficient thickness to anchor dowel bars is located. The bottom of the patch is to be as shown in the contract documents – usually at the bottom of the adjacent pavement, as shown in **Standard Drawing 506-CCPP-02**. All subbase that has been disturbed during the removal process is required to be compacted.

One problem that Contractors sometimes have during the concrete removal operation involves the binding of blades when attempting saw cuts. Typically, this is caused by performing the saw cut during hot weather when the existing pavement is undergoing thermal expansion. This problem is usually alleviated by performing the saw cuts during times of the day when temperatures are cooler.

PLACEMENT OF PATCHING MATERIALS

For patches which are not overlaid and with a length greater than 20 ft, pavement smoothness will be in accordance with **SS 501.25**, except that Inertial Profiler requirements will not apply. The longitudinal smoothness will be measured with a 16 ft straightedge and the transverse will be measure with a 10 ft straightedge.

PARTIAL DEPTH PATCHES

The requirements associated with placing patching materials in partial depth patches are contained in **SS 506.11(a)**.

The Technician's primary responsibility is to ensure the existing concrete is clean of debris, dirt, and dust prior to placement of patching concrete. If any such debris, dirt, or dust comes into contact with the patch bonding agent prior to placing the patch, it must be removed and the bonding agent reapplied. If the existing pavement is not clean when the patching material is placed, the performance and longevity of the patch will be compromised.

The Technician also must be mindful that the patching material is placed within the appropriate time after application of the bonding agent. The manufacturer of the bonding agent will recommend a time limit for the placement of the patching concrete. The Technician should request to see the manufacturer's recommendations. If the recommendations are not provided, the Technician must alert the PEMS as soon as possible.

The Technician also needs to verify that the patching concrete is vibrated during the placement operation. The vibrator should not come in contact with the existing concrete.

If the partial depth patch is located at an existing pavement contraction joint, the Technician must verify that the Contractor installs a joint filler or form. The Technician must contact the PEMS as soon as possible if the Contractor does not provide joint filler at required locations.

If a partial depth patch is constructed in a manner that fails to meet **SS 506.10(a)** requirements, the performance and longevity of the patch will be compromised. Partial depth patches that have failed require considerable maintenance effort and expense and typical maintenance efforts result in a very poor ride for the motorist.

FULL DEPTH PATCHES

Full depth patches are generally required to have dowel bars installed in the adjoining pavement in accordance with **Standard Drawing E506-CCPP-02**.

The Technician's responsibilities during the placement of the full depth patching concrete generally include the following:

- Verify that the dowel bar holes are drilled correctly.
- Ensure proper application of the dowel bar chemical anchoring system.
- Ensure that long patches (greater than 15 ft.) include D-1 contraction joints.
- Verify appropriate weather conditions for patching.
- Verify patching concrete mixing requirements are met.
- Acquire required samples and perform associated tests.
- Verification of patch concrete vibration.

The purpose of the dowel bar installation is to facilitate load transfer between the patch and the existing pavement. In order for this to be accomplished, the holes must be drilled at the mid-depth of the existing pavement; they must be drilled to the proper length; and they need to be drilled parallel to the flow of traffic horizontally and vertically.

In addition to alignment issues, the load transfer cannot be accomplished if the dowel bar is not securely in place. Therefore, the Technician must verify that the anchoring of the dowel bar is performed properly. The hole as well as the portion of the dowel bar that is inserted into the hole in the existing pavement must be adequately covered with a chemical anchoring system. Also, as the dowel is inserted into the hole, it needs to be done with a twisting motion so that the entire perimeter of the dowel is uniformly coated with the anchoring material.

Patches that are longer than 15 ft need to include contraction joints to ensure proper performance of the patch. These joints need to match the locations of joints in adjacent lanes. Random cracking of the patch or the adjacent pavement may occur if the contraction joints are not located properly within the patch.

Adverse weather conditions negatively affect the performance of full depth patches. Weather limitations are included in **SS 506.10**. PCCP patches shall not be placed on frozen subgrade, subbase, or PCCP. The Technician is responsible for notifying the PEMS if the Contractor proposes to construct the full depth patches under conditions prohibited by the contract. If the Technician has any questions regarding whether the existing concrete pavement is continually reinforced, the PEMS should be contacted for confirmation.

Because the patching concrete is designed to achieve high strengths quickly, the Technician must stay on top of the mixing requirements as well as the unloading time requirements. These requirements are included in **SS 506.09**. Patching material that is not mixed well cannot reach the desired strength. As the patching mix reaches its time limit for placement, it becomes unworkable resulting in a mix that will not meet the required performance requirements and it can damage mixers and equipment associated with the placement operation.

In addition to verifying the patching material mixing requirements, the Technician is responsible to verify that the batch weights for its various components are within the CMDP tolerances included in **SS 506.04**. If the tolerances are not met, the Technician needs to notify the PEMS as soon as possible.

While the placement of the patching concrete is ongoing, the Technician is responsible for obtaining samples and performing acceptance testing in accordance with the Manual for Frequency of Sampling and Testing. The Technician is also responsible for verifying that the patching mix is being vibrated in accordance with **SS 506.11**.

After completion of the construction of the full depth patch, the Technician needs to verify that the patch is textured and tined unless the patch is to be overlaid by HMA or if the patch and existing pavement is to receive diamond grinding. The final responsibility of the Technician in terms of the patching operation is verification that the patch is cured in accordance with **SS 504.04(a)** and **506.11**. In addition, if the ambient temperature is below 55 degrees polyethylene film shall be placed over the patch and covered with a 4 in layer of rigid or flexible insulation and firmly anchored.

CURING & OPENING TO TRAFFIC

Normally it is important to open the patched lane to traffic as soon as possible after completion of the patching operation. In order to accomplish this, the patches are to be cured in accordance with **SS 504.04(a)** and **506.11**. Once that is done, **SS 506.12(a)** Patches less than 15 ft includes the requirements that must be met prior to opening the patched lane to traffic.

There are two methods of determining when the patched lane can accommodate traffic loading. One is based on the air temperature at the time of patch construction or the concrete temperature at the time of delivery, whichever is lower (Table 9-1). Cooler air temperatures and concrete temperatures require longer curing periods. If calcium chloride or other admixtures

| T | H | HT | T | H | HT |
|-----------|----|----|------------|----|----|
| 40 - 42°F | 30 | 26 | 61 - 63°F | 14 | 9 |
| 43 - 45°F | 27 | 23 | 64 - 66°F | 14 | 9 |
| 46 - 48°F | 24 | 21 | 67 - 69°F | 14 | 8 |
| 49 - 51°F | 21 | 19 | 70 - 72°F | 14 | 7 |
| 52 - 54°F | 19 | 16 | 73 - 75°F | 14 | 6 |
| 55 - 57°F | 16 | 14 | above 75°F | 14 | 5 |
| 58 - 60°F | 16 | 11 | | | |

T = Lowest ambient temperature during placement, or the temperature of concrete at time of delivery, whichever is lower
H = Time in hours to open to traffic
HT = Time in hours to open to traffic when the average daily traffic is less than 10,000

Table 9-1 Open to Traffic Time & Temperature Chart

systems are used, the second method is based on flexural strength of beams that were cast at the time of patch concrete placement. Once a beam breaks with a modulus of rupture that is greater than or equal to 300 psi, the patched pavement may be opened to traffic regardless of the time that has elapsed since the patches were constructed.

For patches greater than 15 ft in length traffic shall not be allowed on the PCCP until a modulus of rupture of 425 psi from flexural strength testing is achieved. The modulus of rupture will be determined by averaging two beams.

METHOD OF MEASUREMENT

Partial depth and full depth patching are measured by the square yard. D-1 contraction joints and retrofitted tie bars used in patches are measured in accordance with **SS 503.07**. When subgrade treatment is specified, it will be measured in accordance with **SS 207.05**. New subbase will be measured in accordance with **SS 302.08**.

The cost of retrofit pressure relief joints, retrofit contraction joints, non-vapor barrier bonding agent, anchored dowel bars installed at the beginning and end of the patch, individual dowel bars, joint fillers, joint materials, drilling holes for dowel bars, grout retention rings, and chemical anchoring system shall be included in the cost of PCCP patching.

BASIS OF PAYMENT

PCCP patching is paid for at the contract unit price per square yard for the type of patching required. D-1 contraction joints and retrofitted tie-bars used in the patches are paid for in accordance with **SS 503.08**.

Partial depth patches, which have been directed to be made full depth, are paid for in accordance with **SS 506.14**.

The cost of concrete removal, patching, and all necessary incidentals identified in Method of Measurement is included in the cost of the appropriate concrete pavement patching pay item.

The cost of corrections for pavement smoothness and re-texturing shall be included in the cost of PCCP patching.

CHAPTER TEN: *QC/QA PCCP AND PCCP*

The requirements associated with QC/QA PCCP are found in **SS 501**. QC/QA PCCP is generally used on contracts with large quantities of concrete pavement. The requirements associated with PCCP are found in **SS 502**. PCCP is generally used for pay items with small quantities. The acceptance requirements for PCCP will be discussed at the end of this chapter.

The QC in QC/QA PCCP refers to Quality Control – the Contractor’s responsibility. The Contractor must submit a Quality Control Plan, or QCP, which describes the processes that it intends to use to produce the concrete mix. The QCP also outlines the sampling and testing the Contractor intends to perform to control the production, hauling, and paving operations, as well as proposed corrective actions should the QC testing indicate that the concrete is not meeting Contract requirements.

QA, or Quality Assurance, on the other hand, is INDOT’s responsibility. The Technician will take samples and perform testing in accordance with the Frequency Manual, and test results determine whether the concrete mix meets Contract requirements.

In addition to determining compliance with **SS 501** requirements, QA test results help determine adjustments in payment to be made to the Contractor, or QA Adjustments. In general, test results that exceed Contract requirements result in additional compensation to the Contractor for providing quality product. If the test results simply *meet SS 501* requirements, there is no adjustment in compensation. If the test results indicate that the paving concrete is marginally deficient, the QA adjustment reduces compensation to the Contractor. If the QA test results indicate that the concrete performance is substantially below **SS 501** requirements, the represented pavement is considered a failed material, and a separate Failed Materials process is followed to determine the magnitude of deficiency, to reduce compensation – often substantially – or even require the pavement be removed and replaced.

SUBLOTS AND LOTS

Sampling and testing are based on statistical principles. In simplistic terms, the total quantity of each QC/QA PCCP pay item is divided into lesser quantities referred to as lots. Each lot is then further subdivided into sublots. The Manual for Frequency of Sampling and Testing includes the required sampling and testing frequency for each subplot or lot of paving concrete. Once these samples are taken and the associated tests are run, the test results are assumed to represent the performance of the entire subplot or lot as applicable. Therefore, the resulting QA adjustment that is determined from the test result is applied to the lot or subplot quantity that the test result represents.

For QC/QA PCCP, a subplot typically consists of 2,400 square yards. A partial subplot of 480 square yards or less is considered as part of the previous subplot and a partial subplot greater than 480 square yards is considered an individual subplot.

A lot typically consists of three sublots or 7,200 square yards of concrete for each mix design. If there are one or two sublots in an incomplete lot, then the quantity of material is considered a lot. Therefore, a lot may contain one, two, or three sublots.

If the concrete is placed at several locations on the Contract, then the sublots are determined in the order that the material was placed. The Technician is responsible for keeping track of the pavement locations associated with each subplot and lot. This can be difficult if the Contractor has multiple paving crews or if the paving operation does not continuously move through the contract area. This is common for concrete pavements that have to be constructed while maintaining traffic at intersections or at driveways to adjoining properties. Recording the progression of paving from location to location in your Daily Work Report can help considerably when it comes to determining where a lot and its sublots were placed. If needed, the Technician can consult the PEMS for additional methods for tracking paving locations.

RANDOM SAMPLING

Sampling of material for acceptance testing is done by INDOT on a random basis using **ITM 802**. A random target area for plastic concrete within a subplot is determined and the location of the random sample is established. Cores for thickness are determined by establishing random longitudinal and transverse locations. The random locations are not given to the Contractor so that there is no possible influence on the production operations.

For all samples, except for cores required to measure pavement thickness, the random sample is taken from the location corresponding to the selected quantity within the subplot or lot as applicable. For cores, the random sample is taken from a randomly determined station and offset within the subplot. Additional information regarding determination of sample locations is included in the following section.

SAMPLING PROCEDURE

The Contractor is required to provide the concrete and necessary labor for obtaining all required QA samples. QA sampling is performed in accordance with **AASHTO R 60**.

RANDOM NUMBERS

Table 10-1 Random Numbers, per **ITM 802** is used to determine the random sample location. The numbers occur in this table randomly and are in no particular order. Therefore, samples obtained using this method and table are truly random and eliminate selection bias.

To use the Random Number table, first select one block in the table without looking. This selection determines the *block* to be used – the surrounding 10 numbers within the thick outline. After selecting the block, the top left number in the block is the first random number used. If a pair of random numbers is needed, adjacent numbers within the block are used. Proceed down the vertical column for additional numbers. Upon reaching the bottom, proceed to the top of the column to the right, if available, and continue. When the bottom of the right-most column is reached, proceed to the top of the left-most column, and continue until you have used every random number on the table. When all random numbers have been

In accordance with these instructions, to determine a random *station*, a single random number will be used; to determine a random *location* (coordinate, i.e., station + offset), a pair of random numbers will be used.

| | | | | | | | | | |
|-------|-------|-------|-------|-------|-------|-------|-------|-------|-------|
| 0.576 | 0.730 | 0.430 | 0.754 | 0.271 | 0.870 | 0.732 | 0.721 | 0.998 | 0.239 |
| 0.892 | 0.948 | 0.858 | 0.025 | 0.935 | 0.114 | 0.153 | 0.508 | 0.749 | 0.291 |
| 0.669 | 0.726 | 0.501 | 0.402 | 0.231 | 0.505 | 0.009 | 0.420 | 0.517 | 0.858 |
| 0.609 | 0.482 | 0.809 | 0.140 | 0.396 | 0.025 | 0.937 | 0.310 | 0.253 | 0.761 |
| 0.971 | 0.824 | 0.902 | 0.470 | 0.997 | 0.392 | 0.892 | 0.957 | 0.040 | 0.463 |
| 0.053 | 0.899 | 0.554 | 0.627 | 0.427 | 0.760 | 0.470 | 0.040 | 0.904 | 0.993 |
| 0.810 | 0.159 | 0.225 | 0.163 | 0.549 | 0.405 | 0.285 | 0.542 | 0.231 | 0.919 |
| 0.081 | 0.277 | 0.035 | 0.039 | 0.860 | 0.507 | 0.081 | 0.538 | 0.986 | 0.501 |
| 0.982 | 0.468 | 0.334 | 0.921 | 0.690 | 0.806 | 0.879 | 0.414 | 0.106 | 0.031 |
| 0.095 | 0.801 | 0.576 | 0.417 | 0.251 | 0.884 | 0.522 | 0.235 | 0.389 | 0.222 |
| 0.509 | 0.025 | 0.794 | 0.850 | 0.917 | 0.887 | 0.751 | 0.608 | 0.698 | 0.683 |
| 0.371 | 0.059 | 0.164 | 0.838 | 0.289 | 0.169 | 0.569 | 0.977 | 0.796 | 0.996 |
| 0.165 | 0.996 | 0.356 | 0.375 | 0.654 | 0.979 | 0.815 | 0.592 | 0.348 | 0.743 |
| 0.477 | 0.535 | 0.137 | 0.155 | 0.767 | 0.187 | 0.579 | 0.787 | 0.358 | 0.595 |
| 0.788 | 0.101 | 0.434 | 0.638 | 0.021 | 0.894 | 0.324 | 0.871 | 0.698 | 0.539 |
| 0.566 | 0.815 | 0.622 | 0.548 | 0.947 | 0.169 | 0.817 | 0.472 | 0.864 | 0.466 |
| 0.901 | 0.342 | 0.873 | 0.964 | 0.942 | 0.985 | 0.123 | 0.086 | 0.335 | 0.212 |
| 0.470 | 0.682 | 0.412 | 0.064 | 0.150 | 0.962 | 0.925 | 0.355 | 0.909 | 0.019 |
| 0.068 | 0.242 | 0.777 | 0.356 | 0.195 | 0.313 | 0.396 | 0.460 | 0.740 | 0.247 |
| 0.874 | 0.420 | 0.127 | 0.284 | 0.448 | 0.215 | 0.833 | 0.652 | 0.701 | 0.326 |
| 0.897 | 0.877 | 0.209 | 0.862 | 0.428 | 0.117 | 0.100 | 0.259 | 0.425 | 0.284 |
| 0.876 | 0.969 | 0.109 | 0.843 | 0.759 | 0.239 | 0.890 | 0.317 | 0.428 | 0.802 |
| 0.190 | 0.696 | 0.757 | 0.283 | 0.777 | 0.491 | 0.523 | 0.665 | 0.919 | 0.246 |
| 0.341 | 0.688 | 0.587 | 0.908 | 0.865 | 0.333 | 0.928 | 0.404 | 0.892 | 0.696 |
| 0.846 | 0.355 | 0.831 | 0.218 | 0.945 | 0.364 | 0.673 | 0.305 | 0.195 | 0.887 |
| 0.882 | 0.227 | 0.552 | 0.077 | 0.454 | 0.731 | 0.716 | 0.265 | 0.058 | 0.075 |
| 0.464 | 0.658 | 0.629 | 0.269 | 0.069 | 0.998 | 0.917 | 0.217 | 0.220 | 0.659 |
| 0.123 | 0.791 | 0.503 | 0.447 | 0.659 | 0.463 | 0.994 | 0.307 | 0.631 | 0.422 |
| 0.116 | 0.120 | 0.721 | 0.137 | 0.263 | 0.176 | 0.798 | 0.879 | 0.432 | 0.391 |
| 0.836 | 0.206 | 0.914 | 0.574 | 0.870 | 0.390 | 0.104 | 0.755 | 0.082 | 0.939 |
| 0.636 | 0.195 | 0.614 | 0.486 | 0.629 | 0.663 | 0.619 | 0.007 | 0.296 | 0.456 |
| 0.630 | 0.673 | 0.665 | 0.666 | 0.399 | 0.592 | 0.441 | 0.649 | 0.270 | 0.612 |
| 0.804 | 0.112 | 0.331 | 0.606 | 0.551 | 0.928 | 0.830 | 0.841 | 0.702 | 0.183 |
| 0.360 | 0.193 | 0.181 | 0.399 | 0.564 | 0.772 | 0.890 | 0.062 | 0.919 | 0.875 |
| 0.183 | 0.651 | 0.157 | 0.150 | 0.800 | 0.875 | 0.205 | 0.446 | 0.648 | 0.685 |

Table 10-1 Random Numbers per ITM 802

SAMPLE LOCATION – PLASTIC CONCRETE

The location where the random sample is obtained is calculated using the random target area procedure of **ITM 802** as follows:

1. Select a random number.
2. Multiply the random number by the subplot area to obtain the Random Target Area.
3. Divide the sample segment size by the width of the area and round to the nearest 0.1 ft. length. The resulting number is the length of the random target area.
4. Add this length to the starting station of the subplot to obtain the testing station.

The following examples explain the procedure for obtaining the random target area.

EXAMPLE NO. 1

PCCP is being placed at a width of 12 ft and the starting station of the subplot is 102+50. The subplot size is 2400 yd². What is the random sample station given random # 0.830?

$$\begin{aligned} \text{Random Number} &= 0.830 \\ \text{Random Target Area} &= 2400 \times 0.830 \\ &= 1992 \text{ yd}^2 \\ \text{Length of Random Target Area} &= \frac{\text{Target Area (yd}^2\text{)}}{\text{Width (nearest 0.1 ft)}} \times \frac{9 \text{ ft}^2}{1 \text{ yd}^2} = \frac{1992}{12} \times 9 \\ \text{Distance to Random Sample} &= 1494 \text{ ft} \end{aligned}$$

The sample is obtained at 1494 feet from the beginning station of the subplot (102+50).

$$\text{Random Sample Station} = 10250 + 1494 = 117+44$$

EXAMPLE NO. 2

PCCP is being placed at a width of 24 ft and the starting station of the subplot is 165+00. The subplot size is 550 yd². What is the random sample station given random # 0.361?

$$\begin{aligned} \text{Random Number} &= 0.361 \\ \text{Random Target Area} &= 550 \times 0.361 \\ &= 198.55 \text{ yd}^2 \\ \text{Length of Random Target Area} &= \frac{\text{Target Area (yd}^2\text{)}}{\text{Width (nearest 0.1 ft)}} \times \frac{9 \text{ ft}^2}{1 \text{ yd}^2} = \frac{198.55}{24} \times 9 \\ \text{Distance to Random Sample} &= 74.46 \text{ ft} \end{aligned}$$

The sample is obtained at 74 feet from the beginning station of the subplot (165+00).

$$\text{Random Sample Station} = 16500 + 74 = 165+74$$

SAMPLE LOCATION – CORES

The location where the random core for thickness is obtained using the random location per area procedure of **ITM 802** is as follows:

1. Identify the subplot from which a random location is required.
2. Select a pair or random numbers from the random number table (Table 10-1). Use the first number for the longitudinal location and the second number for the transverse location.
3. Determine the length of the subplot.
4. Multiply the longitudinal length by the first random number.
5. Multiply the transverse width by the second random number.
6. The resulting numbers represent the random location.

The station at which a core is taken is determined using the length of pavement required for the subplot of PCCP. The transverse distance is determined using the width of pavement being placed and is measured from the right edge of the lane determined by looking in the direction of increasing station numbers. Computations for the longitudinal distance and the transverse distance are made to the nearest whole foot.

Cores are not taken at the following locations:

1. Less than 6 in from the edge of pavement.
2. Less than 2 ft from a D-1 contraction joint.
3. Less than 3 in from the longitudinal joint.
4. Less than 5 ft from a transverse construction joint.

If a core location is less than 2 ft from a D-1 contraction joint, a new location will be determined by subtracting or adding 2 feet from the random station. If a core location is less than 3 in from a longitudinal joint, a new location will be determined by subtracting or adding 3 in from the random transverse distance. If a core location is less than 5 ft from a transverse construction joint, a new location will be determined by subtracting or adding 5 ft from the random station. If a core location is less than 6 in from the edge of pavement, a new location will be determined by subtracting or adding 6 in from the random transverse distance. If a core location is over a dowel bar, a new location will be determined by subtracting or adding 3 ft from the random station.

EXAMPLE

A PCCP is being placed at a width of 12 ft and the starting station of the subplot is 75+00. The subplot size is 2400 yd². Determine station and offset using random #s 0.935 and 0.114.

| | | |
|-----------------------|---|------------------------------|
| Random Numbers | 0.935, 0.114 | |
| Length of Sublot | = $\frac{\text{Sublot Size (yd}^2\text{)}}{\text{Width (nearest 1 ft)}} \times \frac{9 \text{ ft}^2}{1 \text{ yd}^2}$ | = $\frac{2400}{12} \times 9$ |
| Longitudinal Distance | = $1800 \text{ ft} \times 0.935$ | = 1683 ft |
| Random Station | = $7500 + 1683$ | = $91+83$ |
| Transverse Distance | = 12×0.114 | = 1.4 ft |
| | Round Transverse Distance to | 1 ft |

TRIAL BATCH DEMONSTRATION

A Trial Batch Demonstration, or TBD, is required for each proposed concrete mix design submittal, CMDS. TBD requirements are included in **SS 501.06**. The purpose of the TBD goes beyond verifying that the concrete meets all requirements. The TBD also provides an opportunity for Contractor personnel and the Technician to verify proper equipment calibration and testing procedures prior to any concrete placement on the contract. The Contractor and the PEMS are required to both be assured that QC testing accurately represents the concrete for any process control decision and QA testing assesses the proper QA adjustment, if any. Failure to accomplish this at the TBD may result in an inaccurate assessment of QA adjustments or erroneous failed material investigations.

The results from a successful TBD provide the Contractor with baseline properties from which to plan process control for production of the concrete mixture. Future changes in properties of aggregates, pozzolans, cements, and admixtures may also be compared to the results at the time of the TBD so effects on concrete properties the day of placement may be anticipated.

The TBD also provides an opportunity for Contractor personnel and the Technician to witness the process upstream from the plant (i.e., material receipt, storage, and handling), through batching and actual concrete production. The complete process is inspected to provide insight as to any potential process control problems prior to job placement. A properly conducted TBD may work to resolve many problems which would otherwise not become evident until the first day of the pavement construction.

The trial batch is required to be of sufficient quantity to allow the Contractor and the Technician to conduct all the required tests from the same batch. The concrete is not to be used for more than one test, except the concrete used for the unit weight may be used to conduct the air content test.

The target unit weight and water/cementitious ratio of the concrete are determined by the trial batch. The flexural strength is determined by averaging a minimum of two beam breaks. All Technician test results are given to the Contractor.

The TBD test results are required to be added to the submittal of the concrete mix design production, CMDP. An approved CMDP from a previous contract may be considered for approval instead of conducting the trial batch.

QUALITY ASSURANCE TESTING

The Technician is responsible for performance of QA testing. For additional information regarding test procedures, refer to Chapter Three: Concrete Job Control.

QA test results are shared with the Contractor. The flexural strength, air content, unit weight, water/cementitious ratio, and thickness are measured for acceptance. The frequency, test method, and precision of test results are included in **Reference 15** of the Manual for Frequency of Sampling and Testing.

SMOOTHNESS

The PCCP smoothness is required to be determined in accordance with **SS 501.25**. When an inertial profiler is used to verify smoothness, the Technician is to make sure the contractor has followed the INDOT IRI Field Guide, found [here](#).

THICKNESS

Thickness requirements are contained in **SS 501.26**. The Technician must be aware of the requirements of **ITMs 404** and **802**. The location adjustments included in **ITM 802** are also important as cores taken near pavement edges or longitudinal joints may not be an accurate representation of the pavement thickness throughout the lot and coring too close to a contraction joint or transverse construction joint could damage a dowel bar or the coring equipment. The Technician needs to follow the **ITM 404** requirements for core measurement because the thickness QA adjustment is based on the measurement and subbase aggregate can attach itself to the bottom of the core which complicates the measurement.

The Technician must observe the coring operation and take immediate possession of the cores. This ensures that the cores subjected to the thickness measurement are the ones taken from the pavement at the required location.

UNIT WEIGHT

The concrete unit weight requirements are contained in **SS 501.27(a)**. Sublots shall not vary by more than $\pm 3.0\%$ from the target unit weight. A stop paving order will be issued if the plastic unit weight exceeds $\pm 3.0\%$ from the target plastic unit weight (mass). Paving operations shall not resume until satisfactory changes are made or an alternate CMDP is used.

The Technician must compare the test result to the concrete mix design production, CMDP, target unit weight. If the test result varies by more than the tolerance included in **SS 501.27(a)** compared to the target value, notify the PEMS as soon as possible so the paving operation can be suspended. INDOT has determined that the performance of a concrete pavement with a unit weight outside the specification tolerance is of no value; therefore, the paving operation should be suspended immediately upon a failing test result.

WATER/CEMENTITIOUS RATIO

Water/cementitious ratio requirements are included in **SS 501.27(b)**. The weekly water to total cementitious materials ratio shall not vary more than ± 0.030 of the target value or exceed the maximum allowed for the appropriate mixture in accordance with **SS 501.05**. Out-of-tolerance variance in the water/cementitious ratio is severely detrimental to pavement performance, and a stop paving order will be issued if the test results exceed these limits. Paving operations cannot resume until changes are made or an alternate CMDP is used. The Technician must compare water/cementitious ratio test results to the CMDP target values and the maximum ratio indicated in **SS 501.27(b)**. Again, the Technician must notify the PEMS of failing test results as soon as possible so the paving operation can be suspended.

FLEXURAL STRENGTH

Flexural strength requirements are included in **SS 501.27(c)**. Average lot values for modulus of rupture of 570 psi (4,000 kPa) and above shall be achieved. Price adjustments for values outside the tolerance limits will be in accordance with **SS 501.28** Pay Factors.

Flexural strength testing requires the casting of beams using concrete associated with the paving operation. These beams are allowed to cure and then are placed in a beam breaker that measures the flexural strength of the beam at the time of rupture.

There are also flexural strength requirements associated with opening newly constructed pavement to construction and non-construction traffic. In addition to the beams cast for acceptance, the Technician needs to also cast sufficient beams to allow for monitoring of the flexural strength required to allow traffic on the newly constructed pavement.

AIR CONTENT

Air content requirements are included in **SS 501.27(d)**. The average lot air content values shall not vary more than -1.2% to $+2.2\%$ from the 7.0% target air content. The range of subplot air content values shall not exceed 2.5% .

When interpreting air content test results, the Technician must also consider the range of the results across the lot. Not only is it important that air content for sublots be within specified tolerances, but also that air content be consistent throughout the entire pavement.

CONTRACTOR APPEAL

If the Contractor does not agree with the QA test results for a lot of QC/QA PCCP, an appeal may be submitted. The appeal procedure is outlined in **SS 501.29**.

PAY FACTORS

The Technician will be responsible for determination of pay factors associated with test results for flexural strength, air content, air content range, thickness, and smoothness. These pay factors are applied to the product of the quantity and the unit price for the QC/QA PCCP pay item in order to determine the QA adjustment for each lot. The lot QA adjustments for each QC/QA PCCP pay item are then added together to determine the total QA adjustment.

MODULUS OF RUPTURE

The information regarding pay factor determination is found in **SS 501.28(a)**. Concrete that is found to have higher modulus of rupture values make strong pavements that are more likely to provide an acceptable service life.

AIR CONTENT

Air content pay factor information is included in **SS 501.28(b)**. There are separate pay factors for the lot average air content and for the range of subplot air contents in the lot.

Air content is different than some other properties as there is a range of acceptable values and as the content varies in either direction, the pavement performance decreases. Concrete with too much air is prone to damage related to moisture and de-icing chemicals and concrete with too little air are susceptible to distresses related to freeze-thaw cycles. This is why there is pay factors associated with the subplot air content range within a lot. The air content tests for a lot might indicate that one subplot has a low content, one has an acceptable content, and one has a high content. The average content for such a situation might justify a pay factor of 1.00 for the lot average, but the reality is that only one subplot has an acceptable air content.

THICKNESS

Thickness pay factor information is contained in **SS 501.28(c)**. Thicker pavements are capable of carrying heavier loads than thinner ones.

SMOOTHNESS

Smoothness pay factors are determined in accordance with **SS 501.25**.

Smooth pavements provide a more comfortable ride for the motorist and also provide a longer service life. A rough pavement will be subjected to more impact loading as traffic essentially bounces down the pavement. Smooth pavements cause less bounce from the traffic loads. Impact loading accelerates the pavement deterioration and reduces the service life of the pavement. The maximum value for any smoothness section in which the Contractor takes corrective action is 1.00 regardless of the results provided by the Inertial Profiler.

QUALITY ASSURANCE ADJUSTMENT

FLEXURAL STRENGTH, AIR CONTENT, AIR CONTENT RANGE – BY LOT

Three quality adjustments are calculated for each lot, one each for flexural strength, q_F , air content, q_A , and air content range, q_R , each using their own pay factor in the calculation, P_F , P_A , and P_R , respectively.

q_F , q_A , and q_R are calculated as follows:

$$q = L \times U \times (P - 1.00)$$

where:

- q = QA adjustment for each of flexural strength, air content, and air content range
- L = lot quantity, (yd²)
- U = unit price for QC/QA PCCP pay item, (\$/yd²)
- P = pay factors for each of flexural strength, air content, and air content range

THICKNESS – BY SUBLOT

$$q_t = l_t \times U \times (P_T - 1.00)$$

where:

- q_t = QA adjustment for thickness of the subplot
- l_t = subplot quantity for thickness, (yd²)
- U = unit price for QC/QA-PCCP, (\$/yd²)
- P_T = pay factor for thickness

SMOOTHNESS – BY SECTION

$$q_S = A \times U \times (P_S - 1.00)$$

where:

- q_S = QA adjustment for smoothness for one section
- A = area of the section, (yd²)
- U = unit price for the material, (\$/yd²)
- P_S = pay factor for smoothness

TOTAL QUALITY ASSURANCE ADJUSTMENT

The total quality assurance adjustment is the sum of smoothness from all sections plus the sum of flexural strength, air content, air content range, and thickness for each paved lot.

The quality assurance adjustment components are calculated as follows:

- Each QA adjustment for flexural strength q_F , air content q_A , and air content range q_R , are calculated as noted above, and are already determined per lot.
- The QA adjustment for thickness of a lot q_T , is the total of the QA adjustments for thickness for each subplot q_t , as follows:

$$q_T = \sum(q_{t1} + q_{t2} + q_{t3})$$

- The QA adjustment for smoothness for the entire contract item Q_S , will be the total of the QA adjustments for smoothness for each section q_S , as follows:

$$Q_S = \sum q_S$$

With these components we can calculate the total quality assurance adjustment Q as follows:

$$Q = \sum(q_F + q_A + q_R + q_T) + Q_S$$

where:

- Q = total QA adjustment quantity
- Q_S = contract item level QA adjustment for smoothness
- q_F = lot QA adjustments for flexural strength
- q_A = lot QA adjustments for air content
- q_R = lot QA adjustments for range
- q_T = lot QA adjustments for thickness

EXAMPLE

The PCCP has the following test results. Determine the QA Adjustments for the lot.

- Sublot 1 = 2400 sys
- Sublot 2 = 2400 sys
- Sublot 3 = 2400 sys
- Design Depth (DD) = 14.0 in
- Quality Assurance Adjustment for Smoothness (Q_S) = $-\$1200$
- Unit Price = $\$32.00/\text{sys}$

| | <u>Sublot 1</u> | <u>Sublot 2</u> | <u>Sublot 3</u> | <u>Lot Avg.</u> | <u>Pay Factor</u> |
|-------------------|------------------|-----------------|-----------------|-----------------|-------------------|
| Flexural Strength | 565 psi | 560 psi | 570 psi | 565 psi | 0.98 |
| Air Content | 6.2% | 7.4% | 5.3% | 6.3% | 1.00 |
| Air Content Range | 7.4 - 5.3 = 2.1% | | | | 1.00 |

$$q_F = 7200 \times \$32.00 \times (0.98 - 1.00) = -\$4608$$

$$q_A = 7200 \times \$32.00 \times (1.00 - 1.00) = \$ 0$$

$$q_R = 7200 \times \$32.00 \times (1.00 - 1.00) = \$ 0$$

| <u>Thickness</u> | <u>Sublot 1</u> | <u>Sublot 2</u> | <u>Sublot 3</u> |
|---------------------|-----------------|-----------------|-----------------|
| Sublot Average | 14.1 in | 13.9 in | 14.4 in |
| Deviation from DD | +0.1 in | -0.1 in | +0.4 in |
| Pay Factor | 1.00 | 1.00 | 1.02 |
| Adjustment Quantity | 0 | 0 | +1536 |

$$q_{t1} = 2400 \times \$32.00 \times (1.00 - 1.00) = \$ 0$$

$$q_{t2} = 2400 \times \$32.00 \times (1.00 - 1.00) = \$ 0$$

$$q_{t3} = 2400 \times \$32.00 \times (1.02 - 1.00) = \$1536$$

$$q_T = \sum(0 + 0 + 1536) = \$1536$$

Total Quality Assurance Adjustment

$$Q = \sum(-4608 + 0 + 0 + 1536) + (-1200) = -\$4272$$

FAILED MATERIAL

Sublot and lot values that are excessively out of tolerance are subject to review by the Failed Materials Committee, FMC, to determine final payment for the affected pavement. The following test results require FMC consideration:

1. An individual sublot having an air content test value of less than 5.5 percent or more than 10.0 percent.
2. An individual sublot having a Modulus of Rupture value less than 500 psi.
3. A lot having a Modulus of Rupture value average of 514 psi or less.
4. A lot having an air content test value average of less than 5.4% or greater than 10.0%
5. A range of air content of greater than 3.5%.
6. A core thickness that is less than the design depth required pavement thickness by more than 1.00 in.

The FMC may assess a failed materials adjustment that represents a portion or all of the payment that the Contractor received for the work associated with the failed concrete pavement or the FMC may require its removal and replacement.

PCCP ACCEPTANCE

The requirements associated with PCCP are found in **SS 502**. Job control testing requirements are included in **SS 502.05**.

Targets for the CMD:

| | |
|---|------------------------|
| Portland cement content..... | 564 lb/yd ³ |
| Maximum Portland cement content | 752 lb/yd ³ |
| Minimum water/cementitious ratio | 0.340B |
| Maximum water/cementitious ratio | 0.435B |
| Maximum Portland cement reduction for slag cement replacement..... | 30% |
| Slag cement/Portland cement substitution ratio | 1.00 by wt |
| Maximum cement reduction for fly ash replacement | 20% |
| Fly ash/Portland cement substitution ratio | 1.25 by wt |
| Air Content..... | 6.5% |
| Minimum modulus of rupture | 570psi @ 7 days |
| Relative Yield | 1.00 |

Field Acceptance Properties:

| | |
|--|-------------------|
| Minimum water/cementitious ratio | 0.320B |
| Maximum water/cementitious ratio | 0.450B |
| Slump | 2" – 6" |
| Air Content..... | 5.0% – 8.0% |
| Minimum modulus of rupture | 570 psi at 7 days |
| Relative Yield | 0.98 to 1.02 |

In general, PCCP pay items have small quantities. They are typically utilized for mainline pavement for spot improvements such as intersection improvements, site distance corrections, bridge replacements etc. or for approach pavements on any contract. The requirements are similar to those for QC/QA PCCP, but they are different.

As is the case for QC/QA PCCP, the Technician is responsible for witnessing sampling and performing acceptance testing of the concrete used in PCCP. The Manual for Frequency of Sampling and Testing includes information regarding the required sampling and testing frequencies associated with PCCP. It is the Technician's responsibility to ensure that the appropriate number of samples are taken, and acceptance tests are performed.

PCCP acceptance does not incorporate the lot and subplot concept used by QC/QA PCCP. However, for pavement thickness, PCCP utilizes a system based on subsections as described in **SS 502.21(a)**. Core locations within a thickness subsection are determined randomly in a similar fashion as for QC/QA PCCP.

No additional payment will be made for PCCP acceptance test results that exceed **SS 502** requirements. All acceptance test results, except for those associated with pavement thickness, that do not comply with **SS 502** requirements require that the associated PCCP go through the failed materials process.

If a core indicates that pavement thickness within a subsection is deficient, **SS 502.21** describes the procedure required to determine the extent of the thin pavement. **SS 502.21(c)** addresses calculation of the QA adjustment associated with cores that indicate that the deficient thickness is less than or equal to 0.5 in. **SS 502.21(d)** and **502.21(e)** outline the deficient thickness failed material parameters associated with PCCP that may remain in place with no payment to the Contractor and those associated with removal and replacement of the PCCP.

For PCCP, the inertial profiler is not used to measure smoothness. Smoothness of the pavement is verified using the 10 ft and 16 ft straightedges in accordance with **SS 502.20**. Also, flexural strength measurements only apply to determining if the pavement can be opened to traffic and not for acceptance.